

JJ-70.11

CDMA方式携帯自動車電話システム
ノード間インタフェース信号方式

Digital Mobile Communication Network
Inter-Node Interface for CDMA Cellular System

第2版

2000年3月31日制定

社団法人

情報通信技術委員会

THE TELECOMMUNICATION TECHNOLOGY COMMITTEE

COPYRIGHTED MATERIAL

Translated, reproduced and distributed under written permission of the copyright holder (Telecommunications Industry Association) except portions which are modified for Japanese version. The right of copying and distribution of the modified portions of the Japanese version are ascribed to the Telecommunication Technology Committee. Resale or further reproduction in any form is strictly prohibited.

本標準は、日本版として変更されている部分を除き、著作権者 (Telecommunications Industry Association) の文書による許諾を受け、翻訳、複製および頒布されている。日本版における変更部分の複写および頒布する権利は社団法人情報通信技術委員会が保有する。

本標準の再販、またいかなる方法における複製もこれを禁止する。

CDMA 方式携帯自動車電話システムノード間インタフェース信号方式
[Digital Mobile Communication Network Inter-Node Interface for CDMA Cellular System]

<参考> [Remarks]

1 . 英文記述の適用レベル [Application level of English description]

適用レベル [Application level] : E3

本標準の本文、付属資料および付録の文章および図に英文記述を含んでいる。

[English description is included in the text and figures of main body, annexes and appendices.]

2 . 国際勧告等の関連 [Relationship with international recommendations and standards]

本標準は、1997年12月にANSIで標準化されたANSI-41-Dを、日本国内での使用を目的として一部を改修したものである。

[This standard is standardized based on ANSI-41-D, which was standardized by ANSI in Dec. 1997, with some modifications applied in Japan.]

3 . 上記国際勧告等に対する追加項目等 [Departures from international recommendations]

3.1 オプション選択項目 [Selection of optional items]

なし [None]

3.2 ナショナルマター項目 [Items of national matter]

なし [None]

3.3 原標準に対する変更項目 [Changes to original standard]

(1) 原標準が参照する標準のうち、TTC標準・ARIB標準に置き換える項目。 [Standards referred to in the original standard, which are replaced by TTC/ARIB standards.]

表1に示す。 [Refer to Table 1.]

(2) 本標準で追加した項目。 [Items added to the original standard]

表2に示す。 [Refer to Table 2.]

(本文中では*で表示する。 [Those are marked by with * in the main body.])

(3) 本標準で削除した項目。ただし、本標準の理解を助けるために記述は残している。 [Items deleted from the original standard]

表3に示す。 [Refer to Table 3.]

(本文中では#で表示する。 [Those are marked by with # in the main body.])

(4) 本標準で修正した項目。 [Items changed from the original standard]

表4に示す。 [Refer to Table 4.]

(本文中では で表示する。 [Those are marked by with in the main body.])

3.4 原標準との章立て構成比較 [Difference in chapter ordering from the original standard.]

原標準との章立て構成の相違はない。

[There is no difference in chapter ordering from the original standard.]

3.5 その他 [Other]

- (1) 本標準中に記述されている TIA/EIA-41 は、本標準である JJ-70.11 に置換えるものとする。[TIA/EIA-41 described in this standard are replaced by JJ-70.11.]
- (2) 本標準では、MTP/SCCP は TTC 標準を使用する。TC については、TTC 標準である JT-Q77X によらず ANSI 標準を利用する。今後他の TTC 標準との相互動作が必要となる場合、JT-Q77X シリーズの適用に向け、状況を見ながら検討する。[This standard utilizes MTP/SCCP in TTC standard and TC in ANSI standard. If it is necessary to interact between this standard and other TTC standard in the future, this standard will be examined to apply JT-Q77X series.]
- (3) 本標準は原標準に事業者間料金精算方式の記述を追加した。[The addition related to Interconnection charge billing system is included in this standard.]

4 . 改版の履歴 [Change history]

版数 [Revision]	制定日 [Date]	改版内容 [Contents]
第 1 版 [V.1]	1999 年 4 月 22 日	制定 [Newly standardized]
第 2 版 [V.2]	2000 年 3 月 31 日	事業者間料金精算方式に関わる追加 [Addition related to Interconnection charge billing system.]

5 . 工業所有権 [IPR]

本標準に関わる「工業所有権等の実施の権利に係る確認書」の提出状況は、TTC ホームページでご覧になれます。

6 . 参照している勧告、標準等 [Reference]

- TTC 標準(1987 年版)
JT-Q702
- TTC 標準(1990 年版)
JT-Q701, JT-Q707
- TTC 標準(1992 年版)
JT-Q704
- TTC 標準(1997 年版)
JT-Q711, JT-Q712, JT-Q714
- TTC 標準(1998 年度版)
JT-Q713
- ANSI 標準(1988 年版)
T1.111, T1.112, T1.114
- ANSI 標準(1989 年版)
T1.611
- ANSI T1 標準(1991 年版)
T1.209
- ANSI/TIA/EIA 標準(1989 年版)
ANSI/TIA/EIA-553

- ANSI/TIA/EIA 標準(1996 年版)
ANSI/TIA/EIA-660, ANSI/TIA/EIA-664
- TIA/EIA 標準(1992 年版)
IS-54-B
- TIA/EIA 標準(1993 年版)
IS-88, IS-124
- TIA/EIA 標準(1994 年版)
IS-97, IS-91, IS-136
- TIA/EIA 標準 (1995 年版)
IS-95-A, IS-637
- ITU 勸告 (1988 年版)
T.50
- ARIB 標準 (1998 年版)
STD-T53 1.1 版

表 1 本標準で置き換えて参照する標準 [Table 1 Replaced standards referred]

原標準 [original standard]	置き換える標準 [replacement]
ANSI 標準 T1.111 Title : Signaling System Number 7- Message Transfer Part	TTC 標準 JT-Q701, JT-Q702, JT-Q703, JT-Q704, JT-Q707
ANSI 標準 Chapter T1.111.1 Title : Functional Description of the Signaling System	TTC 標準 JT-Q701 Title : メッセージ転送部 信号システムの機能概要
ANSI 標準 Chapter T1.111.2 Title : Signaling Data Link	TTC 標準 JT-Q702 Title : メッセージ転送部 信号データリンク部
ANSI 標準 Chapter T1.111.3 Title : Signaling Link	TTC 標準 JT-Q703 Title : メッセージ転送部 信号リンク機能
ANSI 標準 Chapter T1.111.4 Title : Signaling Network Function and Messages	TTC 標準 JT-Q704 Title : メッセージ転送部 信号網機能部
ANSI 標準 Chapter T1.111.7 Title : Testing and Maintenance	TTC 標準 JT-Q707 Title : メッセージ転送部 試験・保守
ANSI 標準 T1.112 Title : Signaling System Number 7- Signaling Connection Control Part (SCCP)	TTC 標準 JT-Q711, JT-Q712, JT-Q713, JT-Q714
ANSI 標準 Chapter T1.112.1 Title : Functional Description of the Signaling Connection Control Part	TTC 標準 JT-Q711 Title : 信号接続制御部(SCCP)の機能
ANSI 標準 Chapter T1.112.2 Title : Definitions and Functions of SCCP messages	TTC 標準 JT-Q712 Title : SCCP メッセージの定義および機能
ANSI 標準 Chapter T1.112.3 Title : SCCP Formats and Codes	TTC 標準 JT-Q713 Title : SCCP フォーマットとコード
ANSI 標準 Chapter T1.112.4 Title : SCCP Procedures	TTC 標準 JT-Q714 Title : SCCP 手順
TIA/EIA/IS-95-A(CDMA) Title : Mobile Station - Base Station Compatibility Standard for Dual-Mode Wideband Spread Spectrum Cellular System	ARIB STD-T53 1.1 版 Title : CDMA 方式携帯自動車電話システム
TIA/EIA/IS-97(CDMA) Title : Recommended Minimum Performance Standards for Base Station Supporting Dual-Mode Wideband Spread Spectrum Cellular Mobile Station	ARIB STD-T53 1.1 版 Title : CDMA 方式携帯自動車電話システム

表 2 本標準で追加した項目 [Table 2 Added items]

章 [chap]	節 [section]	追加した項目 [item added]	理由 [reason]
1	4	SYMBOLS AND ABBREVIATIONS 中の SS7 を追加。	TTC 表現にするため。
3	4.9.1	ChargingAreaInformation パラ メータを追加。	事業者間料金精算方式に対応するた め。
3	4.9.1	CarrierIdentificationCode パラメー タを追加。	事業者間料金精算方式に対応するた め。
3	4.9.2	ChargingAreaInformation パラ メータを追加。	事業者間料金精算方式に対応するた め。
3	4.9.2	CarrierIdentificationCode パラメー タを追加。	事業者間料金精算方式に対応するた め。
3	4.11.1	ChargingAreaInformation パラ メータを追加。	事業者間料金精算方式に対応するた め。
3	4.11.1	CarrierIdentificationCode パラメー タを追加。	事業者間料金精算方式に対応するた め。
3	4.17.1	ChargingAreaInformation パラ メータを追加。	事業者間料金精算方式に対応するた め。
3	4.17.1	CarrierIdentificationCode パラメー タを追加。	事業者間料金精算方式に対応するた め。
3	4.17.1	MobileAdditionalParty'sCategory3 パラメータを追加。	事業者間料金精算方式に対応するた め。
3	4.17.6	ChargingAreaInformation パラ メータを追加。	事業者間料金精算方式に対応するた め。
3	4.17.6	CarrierIdentificationCode パラメー タを追加。	事業者間料金精算方式に対応するた め。
3	4.17.6	MobileAdditionalParty'sCategory3 パラメータを追加。	事業者間料金精算方式に対応するた め。
3	4.18.1	ChargingAreaInformation パラ メータを追加。	事業者間料金精算方式に対応するた め。
3	4.18.1	CarrierIdentificationCode パラメー タを追加。	事業者間料金精算方式に対応するた め。
3	4.18.2	ChargingAreaInformation パラ メータを追加。	事業者間料金精算方式に対応するた め。
3	4.18.2	CarrierIdentificationCode パラメー タを追加。	事業者間料金精算方式に対応するた め。
3	4.19.1	ChargingAreaInformation パラ メータを追加。	事業者間料金精算方式に対応するた め。
3	4.19.1	CarrierIdentificationCode パラメー タを追加。	事業者間料金精算方式に対応するた め。
3	4.20.2	MobileAdditionalParty'sCategory3 パラメータを追加。	事業者間料金精算方式に対応するた め。

3	4.21.2	ChargingAreaInformation パラメータを追加。	事業者間料金精算方式に対応するため。
3	4.21.2	CarrierIdentificationCode パラメータを追加。	事業者間料金精算方式に対応するため。
3	4.21.2	MobileAdditionalParty'sCategory3 パラメータを追加。	事業者間料金精算方式に対応するため。
3	4.24.1	ChargingAreaInformation パラメータを追加。	事業者間料金精算方式に対応するため。
3	4.24.1	CarrierIdentificationCode パラメータを追加。	事業者間料金精算方式に対応するため。
3	4.26.1	ChargingAreaInformation パラメータを追加。	事業者間料金精算方式に対応するため。
3	4.26.1	CarrierIdentificationCode パラメータを追加。	事業者間料金精算方式に対応するため。
3	4.26.1	MobileAdditionalParty'sCategory3 パラメータを追加。	事業者間料金精算方式に対応するため。
3	4.29.1	ChargingAreaInformation パラメータを追加。	事業者間料金精算方式に対応するため。
3	4.29.1	CarrierIdentificationCode パラメータを追加。	事業者間料金精算方式に対応するため。
3	Annex J.1	事業者間料金精算方式に対応した Initial MS Registration in New serving System フローを追加。	事業者間料金精算方式に対応するため。
3	Annex J.2	事業者間料金精算方式に対応した CD Invocation to an Idle, Local MS フローを追加。	事業者間料金精算方式に対応するため。
3	Annex J.3	事業者間料金精算方式に対応した CD Invocation to an Idle MS on Another MSC フローを追加。	事業者間料金精算方式に対応するため。
3	Annex J.4	事業者間料金精算方式に対応した CFB Invocation フローを追加。	事業者間料金精算方式に対応するため。
3	Annex J.5	事業者間料金精算方式に対応した CFB Invocation with Call Collision フローを追加。	事業者間料金精算方式に対応するため。
3	Annex J.6	事業者間料金精算方式に対応した CFNA Invocation with No Answer or No Response Page フローを追加。	事業者間料金精算方式に対応するため。
3	Annex J.7	事業者間料金精算方式に対応した CFU Invocation フローを追加。	事業者間料金精算方式に対応するため。

5	6.4.2.13	Table 35 中に ChargingAreaInformation パラメータを追加。	事業者間料金精算方式に対応するため。
5	6.4.2.13	Table 35 中に CarrierIdentificationCode パラメータを追加。	事業者間料金精算方式に対応するため。
5	6.4.2.13	Table 35 中の、ChargingAreaInformation、CarrierIdentificationCode パラメータに対して Note J1 を追加。	事業者間料金精算方式に対応するため。
5	6.4.2.21	Table 52 中に ChargingAreaInformation パラメータを追加。	事業者間料金精算方式に対応するため。
5	6.4.2.21	Table 52 中に CarrierIdentificationCode パラメータを追加。	事業者間料金精算方式に対応するため。
5	6.4.2.21	Table 52 中の、ChargingAreaInformation、CarrierIdentificationCode パラメータに対して Note J1 を追加。	事業者間料金精算方式に対応するため。
5	6.4.2.27	Table 64 中に ChargingAreaInformation パラメータを追加。	事業者間料金精算方式に対応するため。
5	6.4.2.27	Table 64 中に CarrierIdentificationCode パラメータを追加。	事業者間料金精算方式に対応するため。
5	6.4.2.27	Table 64 中に MobileAdditionalParty'sCategory3 パラメータを追加。	事業者間料金精算方式に対応するため。
5	6.4.2.27	Table 64 中の、ChargingAreaInformation、CarrierIdentificationCode、MobileAdditionalParty'sCategory3 パラメータに対して Note J1 を追加。	事業者間料金精算方式に対応するため。
5	6.4.2.29	Table 66 中に ChargingAreaInformation パラメータを追加。	事業者間料金精算方式に対応するため。
5	6.4.2.29	Table 66 中に CarrierIdentificationCode パラメータを追加。	事業者間料金精算方式に対応するため。

5	6.4.2.29	Table 66 中の、ChargingAreaInformation、CarrierIdentificationCode パラメータに対して Note J1 を追加。	事業者間料金精算方式に対応するため。
5	6.4.2.30	Table 68 中に ChargingAreaInformation パラメータを追加。	事業者間料金精算方式に対応するため。
5	6.4.2.30	Table 68 中に CarrierIdentificationCode パラメータを追加。	事業者間料金精算方式に対応するため。
5	6.4.2.30	Table 68 中の、ChargingAreaInformation、CarrierIdentificationCode パラメータに対して Note J1 を追加。	事業者間料金精算方式に対応するため。
5	6.4.2.31	Table 70 中の Profile パラメータに対して Note J1 を追加。	事業者間料金精算方式に対応するため。
5	6.4.2.32	Table 73 中の Profile パラメータに対して Note J1 を追加。	事業者間料金精算方式に対応するため。
5	6.4.2.35	Table 78 中に ChargingAreaInformation パラメータを追加。	事業者間料金精算方式に対応するため。
5	6.4.2.35	Table 78 中に CarrierIdentificationCode パラメータを追加。	事業者間料金精算方式に対応するため。
5	6.4.2.35	Table 78 中の、ChargingAreaInformation、CarrierIdentificationCode パラメータに対して Note J1 を追加。	事業者間料金精算方式に対応するため。
5	6.4.2.37	Table 82 中に ChargingAreaInformation パラメータを追加。	事業者間料金精算方式に対応するため。
5	6.4.2.37	Table 82 中に CarrierIdentificationCode パラメータを追加。	事業者間料金精算方式に対応するため。
5	6.4.2.37	Table 82 中の、ChargingAreaInformation、CarrierIdentificationCode パラメータに対して Note J1 を追加。	事業者間料金精算方式に対応するため。
5	6.4.2.37	Table 83 中の Profile パラメータに対して Note J1 を追加。	事業者間料金精算方式に対応するため。
5	6.4.2.40	Table 89 中に ChargingAreaInformation パラメータを追加。	事業者間料金精算方式に対応するため。

5	6.4.2.40	Table 89 中に CarrierIdentificationCode パラメータを追加。	事業者間料金精算方式に対応するため。
5	6.4.2.40	Table 89 中の、ChargingAreaInformation、CarrierIdentificationCode パラメータに対して Note J1 を追加。	事業者間料金精算方式に対応するため。
5	6.5.1.2	Parameter Identifier Code に National Network Use エリアを設定。	国内使用のパラメータを追加するため
5	6.5.2.97	Table 105 中に ChargingAreaInformation パラメータを追加。	事業者間料金精算方式に対応するため。
5	6.5.2.97	Table 105 中に CarrierIdentificationCode パラメータを追加。	事業者間料金精算方式に対応するため。
5	6.5.2.97	Table 105 中に MobileAdditionalParty'sCategory3 パラメータを追加。	事業者間料金精算方式に対応するため。
5	6.5.2.97	Table 105 中の、ChargingAreaInformation、CarrierIdentificationCode、MobileAdditionalParty'sCategory3 パラメータに対して Note J1 を追加。	事業者間料金精算方式に対応するため。
5	6.5.2.J1	ChargingAreaInformation パラメータを追加。	事業者間料金精算方式に対応するため。
5	6.5.2.J2	CarrierIdentificationCode パラメータを追加。	事業者間料金精算方式に対応するため。
5	6.5.2.J3	MobileAdditionalParty'sCategory3 パラメータを追加。	事業者間料金精算方式に対応するため。
5	6.5.2.5	Table117 中のトーン及びアナウンスメントに対して Note1,Note2 及び Note3 を追加。	日本で使用することを前提としているため。
5	6.5.2.5	Table117 中に NPA の後に NDC を追加。	日本で使用することを前提としているため。
5	6.5.2.93	Point Code についての説明を追加。	日本で使用することを前提としているため。
5	6.5.3.2	Point Code についての説明を追加。	日本で使用することを前提としているため。

表3 本標準で削除した項目 [Table 3 Deleted items]

章 [chap]	節 [section]	削除した項目 [item deleted]	理由 [reason]
1	2	REFERENCES のうち本標準では使用しない項目を削除。	北米独自用語のため。
1	7	GENERAL BACKGROUND AND ASSUMPTIONS 全体を削除。	米国における情報のため。
3	4.17.2	Note 中の inter-LATA を削除。	北米独自用語のため。
3	4.17.3	Note 中の inter-LATA を削除。	北米独自用語のため。
3	4.17.5	Note 中の inter-LATA を削除。	北米独自用語のため。
5	6.5.2.58	Notes 中の NANP を削除。	北米独自用語のため。
5	6.5.2.76	Note 中の inter-LATA を削除。	北米独自用語のため。
5	6.5.2.89	Notes 中の NPA-NXX 及び NPA-NXX-XXXX を削除。	北米独自用語のため。
5	6.5.2.90	Table 115 中の inter-LATA Toll 及び inter-LATA Toll を削除。	北米独自用語のため。
5	6.5.2.98	Notes 中の a. を削除。	北米独自用語が含まれているため。
5	6.5.2.113	説明文中の NANP について削除。	北米独自用語のため。
5	6.5.2.113	Notes 中の f. を削除。	日本で使用することを前提としているため。
5	6.5.2.140	Table 177 中の inter-LATA Toll 及び inter-LATA Toll を削除。	北米独自用語のため。
5	6.5.3.2	Table 196 中の inter-LATA Toll 及び inter-LATA Toll を削除。	北米独自用語のため。
5	2.1	説明文中の inter-LATA 及び LATA を削除。	北米独自用語のため。
5	3.2.3	説明文中の ILATA 及び OLATA を削除。	北米独自用語のため。

表 4 本標準で修正した項目 [Table 4 Modified items]

章 [chap]	節 [section]	修正した項目 [item modified]	理由 [reason]
1	5	5.1.5 ISDN 用語解説を修正。	TTC 標準に合わせるため ANSI を削除。
1	5	5.1.9 PSTN 用語解説を修正。	TTC 標準に合わせるため ANSI を削除。
3	4.20.2	Note 中の NPA-NXX 及び NPA-NXX-XXXX を NDC-X1 ~ Xn へ修正。	日本で使用することを前提としているため。
5	6.4.2.31	Table 70 Note 中の NPA-NXX 及び NPA-NXX-XXXX を NDC-X1 ~ Xn へ修正。	日本で使用することを前提としているため。

5	6.4.2.32	Table73 Note 中の NPA-NXX 及び NPA-NXX-XXXX を NDC-X1 ~ Xn へ修正。	日本で使用することを前提としているため。
5	6.4.2.37	Table83 Note 中の NPA-NXX 及び NPA-NXX-XXXX を NDC-X1 ~ Xn へ修正。	日本で使用することを前提としているため。
5	6.5.2.58	Note 中の表現をから北米固有の用語を修正。	日本で使用することを前提としているため。
5	6.5.2.76	Note 中の表現をから北米固有の用語を修正。	日本で使用することを前提としているため。
5	6.5.2.89	Note 中の表現をから北米固有の用語を修正。	日本で使用することを前提としているため。
5	6.5.2.89	Note 中の 911 及び * -911 を 3digits for emergency call へ修正。	日本で使用することを前提としているため。
5	6.5.2.93	ANSI SS7 Point Code を SS7 Point Code に修正。	日本で使用することを前提としているため。
5	6.5.2.93	Figure101 を修正。	日本で使用することを前提としているため。
5	6.5.2.97	Figure105 中の NPA 番号形式を NDC 番号形式へ修正。	日本で使用することを前提としているため。
5	6.5.2.123	Figure134 の標題 ANSI SS7 Point Code を SS7 Point Code に修正。	日本で使用することを前提としているため。
5	6.5.2.123	Figure134 を修正。	日本で使用することを前提としているため。
5	6.5.3.2	Figure187 の標題 ANSI SS7 Point Code を SS7 Point Code に修正。	日本で使用することを前提としているため。
5	6.5.3.2	Figure187 を修正。	日本で使用することを前提としているため。
5	6.5.3.2	Table 196 中の ANSI SS7 Point Code を SS7 Point Code に修正。	日本で使用することを前提としているため。
5	4.32.2	説明中の NPA-NXX を NDC-X1 ~ Xn に修正。	日本で使用することを前提としているため。
5	4.33.3	説明中の NPA-NXX を NDC-X1 ~ Xn に修正。	日本で使用することを前提としているため。
5	4.33.4	説明中の NPA-NXX を NDC-X1 ~ Xn に修正。	日本で使用することを前提としているため。

目次

第一章：機能概要	1-1
第二章：システム間ハンドオフ情報フロー	2-1
第三章：自動ローミング情報フロー	3-1
第四章：OA&M 情報フローと手順	4-1
第五章：信号プロトコル	5-1
第六章：信号手順	6-1

第一章：機能概要

1.	序文	1-1
1.1	目的	1-1
1.2	範囲	1-1
1.3	構成	1-1
2.	参考文献.....	1-2
2.1	標準	1-2
2.2	その他の参考文献.....	1-4
3.	定義と記述規則.....	1-5
3.1	定義	1-5
3.2	記述規則.....	1-11
4.	記号と略語.....	1-14
5.	ネットワーク参照モデル.....	1-24
5.1	機能エンティティ	1-24
5.2	インタフェース参照ポイント.....	1-26
5.3	関連のある参照ポイント.....	1-27
5.4	ネットワーク エンティティ相互関係図.....	1-28
6.	セルラー システム間サービス.....	1-29
7.	一般的なバックグラウンドと想定.....	1-30
8.	制限規定.....	1-32
	インデックス	1-33

第二章：システム間ハンドオフ情報フロー

1.	序文	2-1
1.1	目的	2-1
1.2	範囲	2-1
1.3	構成	2-2
2.	参考文献.....	2-2
3.	用語	2-2
3.1	定義	2-2
3.2	記号と略語.....	2-2
3.3	記述規則.....	2-3
4.	システム間ハンドオフ オペレーション	2-3
4.1	FacilitiesDirective	2-4
4.2	FacilitiesDirective2	2-9
4.3	FacilitiesRelease.....	2-14
4.4	HandoffBack	2-16
4.5	HandoffBack2	2-20
4.6	HandoffMeasurementRequest.....	2-25
4.7	HandoffMeasurementRequest2.....	2-27
4.8	HandoffToThird	2-30
4.9	HandoffToThird2.....	2-34
4.10	InterSystemAnswer	2-39
4.11	Mobile On Channel	2-41
5.	基本的なシステム間ハンドオフ シナリオ	2-42
5.1	ハンドオフ フォワード成功時.....	2-43
5.2	ハンドオフ バック成功時.....	2-45
5.3	タンデム接続を伴うハンドオフ フォワード成功時	2-47
5.4	タンデム接続を伴うハンドオフ バック成功時	2-48
5.5	パスの最短化を行うハンドオフ ツ サード成功時	2-49
5.6	タンデム接続とパスの最短化を行うハンドオフ ツ サード成功時	2-51
5.7	移動機による呼解放成功時.....	2-53

5.8	他のパーティによる呼解放成功時.....	2-55
5.9	応答待ち中の発信移動機のハンドオフ フォワード成功時.....	2-57
5.10	呼び出し中の着信移動機のハンドオフ フォワード成功時.....	2-59
	付属資料A：TIA/EIA-41でのシステム間ハンドオフのために追加されたDMHサポート	2-61

第三章：自動ローミング情報フロー

1.	序文	3-1
1.1	目的	3-1
1.2	範囲	3-1
1.3	構成	3-2
2.	参考文献.....	3-2
3.	用語	3-2
3.1	定義	3-2
3.2	記号と略語.....	3-3
3.3	記述規則.....	3-5
4.	自動ローミング オペレーション	3-6
4.1	AuthenticationDirective	3-6
4.2	AuthenticationDirectiveForward.....	3-17
4.3	AuthenticationFailureReport.....	3-19
4.4	AuthenticationRequest	3-21
4.5	AuthenticationStatusReport	3-36
4.6	BaseStationChallenge	3-41
4.7	BulkDeregistration	3-45
4.8	CountRequest	3-46
4.9	FeatureRequest.....	3-48
4.10	FlashRequest.....	3-53
4.11	InformationDirective.....	3-55
4.12	InformationForward.....	3-57
4.13	InterSystemAnswer.....	3-59
4.14	InterSystemPage	3-60
4.15	InterSystemPage2	3-65
4.16	InterSystemSetup.....	3-70
4.17	LocationRequest	3-73
4.18	MSInactive.....	3-82
4.19	OriginationRequest	3-86

4.20	QualificationDirective.....	3-89
4.21	QualificationRequest.....	3-97
4.22	RandomVariableRequest.....	3-104
4.23	RedirectionDirective	3-106
4.24	RedirectionRequest	3-109
4.25	RegistrationCancellation.....	3-112
4.26	RegistrationNotification	3-118
4.27	RemoteFeatureControlRequest	3-126
4.28	RmoteUserInteractionDirective	3-127
4.29	RoutingRequest.....	3-129
4.30	SMSDeliveryBackward.....	3-135
4.31	SMSDeliverForward	3-139
4.32	SMSDeliveryPointToPoint	3-143
4.33	SMSNotification	3-147
4.34	SMSRequest.....	3-149
4.35	TransferToNumberRequest.....	3-153
4.36	UnreliableRoamerDataDirective.....	3-157
4.37	UnsolicitedResponse.....	3-158
5.	基本的な自動ローミング シナリオ.....	3-162
5.1	登録	3-163
5.2	登録停止.....	3-167
5.3	不活性移動機報告.....	3-169
5.4	認証	3-172
5.5	基本的なフィーチャ処理.....	3-202
5.6	自動ローミング保守.....	3-213
6.	音声フィーチャ シナリオ.....	3-215
6.1	呼配信 (Call Delivery)	3-215
6.2	着信転送 ビジー (Call Forwarding - Busy)	3-237
6.3	着信転送 デフォルト (Call Forwarding - Default)	3-241
6.4	着信転送 無応答 (Call Forwarding - No Answer)	3-245
6.5	着信転送 無条件 (Call Forwarding - Unconditional)	3-247

6.6	呼転送 (Call Transfer).....	3-249
6.7	コール ウェイティング (Call Waiting).....	3-250
6.8	発信者番号通知 (Calling Number Identification Presentation)	3-257
6.9	発信者番号通知制限 (Calling Number Identification Restriction)	3-266
6.10	会議通話 (Conference Calling)	3-276
6.11	ドゥ ノット ディスターブ (Do Not Disturb)	3-285
6.12	柔軟呼出 (Flexible Alerting)	3-287
6.13	メッセージ待機中通知 (Message Waiting Notification)	3-306
6.14	移動機アクセス ハンティング (Mobile Access Hunting)	3-315
6.15	パスワード呼受諾 (Password Call Acceptance)	3-333
6.16	言語選択 (Preferred Language)	3-341
6.17	優先アクセスとチャネル割当 (Priority Access and Channel Assignment)	3-343
6.18	遠隔フィーチャ制御 (Remote Feature Control)	3-347
6.19	選択着信 (Selective Call Acceptance)	3-350
6.20	個人識別番号アクセス (Subscriber PIN Access)	3-355
6.21	個人識別番号インタセプト (Subscriber PIN Intercept)	3-361
6.22	三者通話 (Three Way Calling)	3-369
6.23	音声メッセージ再生 (Voice Message Retrieval)	3-369
6.24	音声プライバシー (Voice Privacy)	3-372
7.	ショート メッセージ サービス シナリオ	3-373
7.1	MS-Based SMEへのショート メッセージ配信成功時	3-373
7.2	現在のアドレスを持たないMS-Based SMEへのショート メッセージ配信拒否時	3-377
7.3	MS-Based SMEへのショートメッセージ配信応答タイムアウト、通知なし	3-379
7.4	MS-Based SMEへのショート メッセージ配信応答タイムアウト、通知あり	3-381
7.5	MS-Based SMEへのショート メッセージ、発SMS付加サービスあり	3-383
7.6	MS-Based SMEから固定のSMEへのショート メッセージ.....	3-385
7.7	MS-Based SMEから固定のSMEへのショート メッセージ、発SMS付加サービスあり ...	3-386
7.8	二つのMS-Based SME間のショート メッセージ成功時	3-387
7.9	二つのMS間のショート メッセージ、発SMS付加サービスあり.....	3-388
7.10	現在のアドレスを持たないSMSRequest延期	3-391
7.11	SMDPP延期	3-393

7.12	配信延期状態でのSMS機能を持つシステム間のローミング	3-394
7.13	配信延期状態でのSMS機能を持たないシステムへのローミング	3-397
7.14	配信延期状態でのSMS機能を持つシステムへのローミング	3-398
7.15	配信延期状態でのSMS機能を持つシステム間のローカル ローミング	3-400
7.16	配信延期状態でのSMS機能を持たないシステムへのローカル ローミング	3-401
7.17	配信延期状態でのSMS機能を持つシステムへのローカル ローミング	3-402
7.18	配信延期状態でのMSC登録停止	3-403
7.19	配信延期状態でのVLR登録停止	3-404
7.20	複数のSMDPPを持つMSC SMSNotification延期	3-405
7.21	MSC-Based SMEとMS-Based SME間でのショートメッセージ	3-407
7.22	HLR-Based SMEとMS-Based SME間でのショートメッセージ	3-408
7.23	MC-Basedフィーチャ制御のための移動機とMC間でのショートメッセージ	3-409
7.24	ハンドオフ後のMS-Based SMEへのショートメッセージ	3-410
7.25	ハンドオフ後のMS-Based SMEからのショートメッセージ	3-412
	付属資料A :	3-414
A.1.	移動機認証のための前提	3-414
A.2.	移動機信号メッセージ暗号化のための前提	3-415
A.3.	移動機音声プライバシーのための前提	3-416
	付属資料J 事業者間料金精算方式に対応した情報フロー例	3-440
J.1.	初期移動機登録	3-441
J.2.	ローカル移動機への呼配信	3-443
J.3.	Another MSC配下の移動機への呼配信	3-445
J.4.	着信転送 ビジー	3-447
J.5.	Call Collision状態での着信転送 ビジー	3-449
J.6.	無応答、ページ無応答状態での着信転送 無応答	3-453
J.7.	着信転送 無条件	3-457

第四章：運用、管理と保守の情報フローと手順

1.	序文	4-1
1.1	目的	4-1
1.2	範囲	4-1
1.3	構成	4-1
2.	参考文献.....	4-1
3.	用語	4-2
3.1	定義	4-2
3.2	記号と略語.....	4-2
3.3	記述規則.....	4-2
4.	システム間 OA&M オペレーション	4-3
4.1	Blocking.....	4-4
4.2	Unblocking.....	4-5
4.3	ResetCircuit.....	4-6
4.4	TrunkTest.....	4-7
4.5	TrunkTestDisconnect.....	4-8
5.	ハンドオフのためのOA&Mメッセージ手順.....	4-9
5.1	ネットワーク フィーチャ.....	4-9
5.2	異常状態.....	4-20
5.3	ハンドオフ回線のためのOA&Mタイマ値.....	4-24
6.	MSC間トランク試験	4-25
6.1	序文	4-25
6.2	試験説明.....	4-25
6.3	試験手順.....	4-26
6.4	トランク試験のためのOA & Mタイマ値.....	4-28
7.	今後の検討課題.....	4-28

第五章：信号プロトコル

1.	序文	5-1
1.1	目的	5-1
1.2	範囲	5-1
1.3	構成	5-2
2.	参考文献.....	5-2
3.	用語	5-2
3.1	定義	5-2
3.2	記号と略語.....	5-2
4.	MAPプロトコル アーキテクチャ	5-3
5.	データ転送サービス.....	5-6
5.1	SS 7信号方式によるデータ転送サービス	5-6
5.2	X.25によるデータ転送サービス	5-10
5.3	ITU No.7信号方式によるデータ転送サービス	5-11
6.	アプリケーション サービス.....	5-14
6.1	アプリケーション サービス アーキテクチャ	5-14
6.2	アプリケーション レイヤ構造.....	5-15
6.3	TCAP フォーマットと手順.....	5-15
6.4	MAPオペレーション	5-24
6.5	MAPパラメータ.....	5-119
7.	MAPコンパチビリティ ガイドラインと規則	5-332
7.1	フォワード コンパチビリティとバックワード コンパチビリティ	5-332
7.2	フォワード コンパチビリティのためのガイドライン	5-332
7.3	バックワード コンパチビリティのためのガイドライン	5-334

第六章：信号手順

1.	序文	6-1
1.1	目的	6-1
1.2	範囲	6-1
1.3	構成	6-1
1.4	記述規則.....	6-2
2.	技術とコンセプト.....	6-5
2.1	システム間ハンドオフ手順.....	6-5
2.2	ショート メッセージ サービス手順.....	6-6
3.	基本的な呼処理.....	6-9
3.1	登録呼タスク.....	6-9
3.2	発信呼タスク.....	6-12
3.3	着信呼タスク.....	6-25
3.4	切断呼タスク.....	6-39
3.5	回復呼タスク.....	6-41
3.6	ハンドオフ呼タスク.....	6-41
4.	システム間手順.....	6-42
4.1	Authentication Directive	6-42
4.2	Authentication Directive Forward.....	6-58
4.3	Authentication Failure Report.....	6-61
4.4	Authentication Request	6-75
4.5	Authentication Status Report	6-92
4.6	Base Station Challenge	6-100
4.7	Blocking.....	6-109
4.8	Bulk Deregistration	6-110
4.10	Count Request.....	6-111
4.11	Facilities Directive (Handoff Forward).....	6-115
4.12	Facilities Directive 2	6-122
4.13	Facilities Release.....	6-124
4.14	Feature Request.....	6-127

4.15	Flash Request	6-138
4.16	Handoff Back (Shoe Lace Prevention).....	6-143
4.17	Handoff Back 2	6-148
4.18	Handoff Measurement Request.....	6-148
4.19	Handoff Measurement Request 2.....	6-151
4.20	Handoff-to-Third (Path Minimization)	6-154
4.21	Handoff-to-Third 2.....	6-166
4.22	Information Directive.....	6-166
4.23	Information Forward	6-170
4.24	Intersystem Answer.....	6-173
4.25	Intersystem Page	6-175
4.26	Intersystem Page 2	6-180
4.27	Intersystem Setup.....	6-185
4.28	Location Request.....	6-188
4.29	MS On Channel.....	6-195
4.30	MS Inactive	6-195
4.31	Origination Request	6-201
4.32	Qualification Directive.....	6-205
4.33	Qualification Request.....	6-210
4.34	Random Variable Request.....	6-218
4.35	Redirection Directive	6-220
4.36	Redirection Request	6-223
4.37	Registration Cancellation.....	6-226
4.38	Registration Notification.....	6-233
4.39	Remote User Interaction Directive.....	6-245
4.40	Reset Circuit.....	6-249
4.41	Routing Request.....	6-250
4.44	SMS Delivery Backward.....	6-261
4.45	SMS Delivery Forward	6-264
4.46	SMS Delivery Point-to-Point	6-267
4.47	SMS Notification	6-285

4.48	SMS Request.....	6-288
4.49	Transfer-To-Number Request	6-296
4.50	Trunk Test.....	6-302
4.51	Trunk Test Disconnect	6-302
4.52	Unblocking	6-302
4.53	Unreliable Roamer Data Directive.....	6-302
4.54	Unsolicited Response.....	6-304
5.	音声フィーチャ手順.....	6-308
5.1	呼配信 (CD)	6-308
5.2	着信転送 ビジー (CFB)	6-315
5.3	着信転送 デフォルト (CFD)	6-318
5.4	着信転送 無応答 (CFNA)	6-322
5.5	着信転送 無条件 (CFU)	6-326
5.6	呼転送 (CT)	6-329
5.7	コール ウェイティング (CW)	6-330
5.8	発信者番号通知 (CNIP)	6-332
5.9	発信者番号通知制限 (CNIR)	6-335
5.10	会議通話 (CC)	6-337
5.11	ドゥ ノット ディスターブ (DND)	6-338
5.12	柔軟呼出 (FA)	6-339
5.13	メッセージ待機中通知 (MWN)	6-348
5.14	移動機アクセス ハンティング (MAH)	6-352
5.15	パスワード呼受諾 (PCA)	6-362
5.16	言語選択 (PL)	6-366
5.17	優先アクセスとチャネル割当 (PACA)	6-367
5.18	遠隔フィーチャ制御 (RFC)	6-369
5.19	選択着信 (SCA)	6-375
5.20	個人識別番号アクセス (SPINA)	6-380
5.21	個人識別番号インタセプト (SPINI)	6-384
5.22	三者通話 (3WC)	6-389
5.23	音声メッセージ再生 (VMR)	6-389

5.24	音声プライバシー (VP)	6-396
6.	共通音声フィーチャ手順	6-397
6.1	着信転送ルーチング	6-397
6.2	デジット分析	6-398
7.	オペレーション タイマ値	6-400
A.	付属資料A: RANDC確認のための手順	6-406
B.	付属資料B: ACにおけるSSD管理のための手順	6-407
C.	付属資料C: 認証応答確認	6-409
D.	付属資料D: SMS無線区間 デリバ ポイント・ポイント	6-411
D1.	MSCによるMS-Based SMEに向けたSMD - REQUESTの起動	6-412
D2.	MS-Based SMEによるSMD-REQUESTの受信	6-414
D3.	MSCによる予期されないSMD-ACKまたはSMD-NAKの受信	6-415
D4.	MS-Based SMEによるMSC向けSMD-REQUESTの起動	6-415
D5.	サービング MSCによるSMD-REQUESTの受信	6-416
D6.	MS-Based SMEによる予期されないSMD-ACKまたはSMD-NAKの受信	6-418
E.	付属資料E: 全体的なサービス論理	6-419
E.1.	序文	6-419
E.2.	GSL図規則	6-420
E.3.	GSL	6-420
F.	付属資料F: 信号強度	6-453
F.1	RegistrationCancellationの運用状態アルゴリズム	6-463
F.2	二重RegistrationNotificationを検出するためのタイマ方法	6-464
F.3	二重RegistrationNotificationを検出するためのタイマ証明方法	6-466

CELLULAR RADIOTELECOMMUNICATIONS INTERSYSTEM OPERATIONS

CONTENTS

CHAPTER 1: FUNCTIONAL OVERVIEW..... 1-1

CHAPTER 2: INTERSYSTEM HANDOFF INFORMATION FLOWS 2-1

CHAPTER 3: AUTOMATIC ROAMING INFORMATION FLOWS 3-1

CHAPTER 4: OA&M INFORMATION FLOWS AND PROCEDURES..... 4-1

CHAPTER 5: SIGNALING PROTOCOLS 5-1

CHAPTER 6: SIGNALING PROCEDURES 6-1

(NOTE: Each chapter has its own detailed Contents.)

1
2
3
4
5
6
7
8
9
10
11
12
13
14
15
16
17
18
19
20
21
22
23
24
25
26
27
28
29
30
31
32
33
34
35
36
37
38
39
40
41
42
43
44
45
46
47
48
49
50
51
52
53
54
55
56
57
58
59
60

1
2
3
4
5
6
7
8
9
10
11
12
13
14
15
16
17
18
19
20
21
22
23
24
25
26
27
28
29
30
31
32
33
34
35
36
37
38
39
40
41
42
43
44
45
46
47
48
49
50
51
52
53
54
55
56
57
58
59
60

(This page intentionally left blank.)

CELLULAR RADIOTELECOMMUNICATIONS INTERSYSTEM OPERATIONS:
CHAPTER 1
FUNCTIONAL OVERVIEW

CONTENTS

10	LIST OF FIGURES.....	ii
12	FOREWORD	iii
14	REVISION HISTORY	iv
17	1 INTRODUCTION	1
18	1.1 OBJECTIVE.....	1
19	1.2 SCOPE	1
20	1.3 ORGANIZATION	1
23	2 REFERENCES.....	2
24	2.1 NORMATIVE REFERENCES	2
25	2.2 INFORMATIVE REFERENCES	4
28	3 DEFINITIONS and DOCUMENTATION CONVENTIONS	5
29	3.1 DEFINITIONS	5
30	3.2 DOCUMENTATION CONVENTIONS.....	11
31	3.2.1 Scenario Diagram Conventions.....	11
32	3.2.2 Scenario Description Conventions	12
35	4 SYMBOLS AND ABBREVIATIONS	14
38	5 NETWORK REFERENCE MODEL.....	24
39	5.1 FUNCTIONAL ENTITIES	24
40	5.1.1 Authentication Center	24
41	5.1.2 Base Station	25
42	5.1.3 Equipment Identity Register	25
43	5.1.4 Home Location Register	25
44	5.1.5 Integrated Services Digital Network	25
45	5.1.6 Message Center	25
46	5.1.7 Mobile Station.....	25
47	5.1.8 Mobile Switching Center	25
48	5.1.9 Public Switched Telephone Network	25
49	5.1.10 Short Message Entity.....	26
50	5.1.11 Visitor Location Register.....	26
51	5.2 INTERFACE REFERENCE POINTS	26
52	5.2.1 Reference Point A	26
53	5.2.2 Reference Point Ai	26
54	5.2.3 Reference Point B	26

5.2.4	Reference Point C	26	1
5.2.5	Reference Point D	26	2
5.2.6	Reference Point Di	26	3
5.2.7	Reference Point E.....	26	4
5.2.8	Reference Point F.....	27	5
5.2.9	Reference Point G	27	6
5.2.10	Reference Point H	27	7
5.2.11	Reference Point M.....	27	8
5.2.12	Reference Point N	27	9
5.2.13	Reference Point Q	27	10
5.2.14	Reference Point Um	27	11
5.3	RELEVANT REFERENCE POINTS	27	12
5.4	NETWORK ENTITY RELATIONSHIP DIAGRAM	28	13
6	CELLULAR INTERSYSTEM SERVICES.....	29	14
7	GENERAL BACKGROUND AND ASSUMPTIONS.....	30	15
8	RESTRICTIONS.....	32	16
INDEX	33	17
			18
			19
			20
			21
			22
			23
			24
			25
			26
			27
			28
			29
			30
			31
			32
			33
			34
			35
			36
			37
			38
			39
			40
			41
			42
			43
			44
			45
			46
			47
			48
			49
			50
			51
			52
			53
			54
			55
			56
			57
			58
			59
			60

LIST OF FIGURES

Figure 1	Diagrammatic Conventions.....	11
Figure 2	Network Reference Model	24
Figure 3	Entity Relationship Diagram.....	28

FOREWORD

This Foreword is not part of this Standard.

This is one of a series of recommendations entitled:

“CELLULAR RADIOTELECOMMUNICATIONS INTERSYSTEM OPERATIONS”

which describe procedures necessary to provide to cellular radio telephone subscribers certain services requiring interaction between different cellular systems.

It is the intention of TIA/EIA TR-45.2 Subcommittee, Cellular System Operations, that this series of recommendations address the ongoing and developing concerns of the Cellular Radiotelecommunications Industry—subscribers, service providers, and manufacturers alike—with regard to useful and effective services requiring standardized intersystem procedures.

The recommendations included in this series are:

- Chapter 1, *Cellular Radiotelecommunications Intersystem Operations: Functional Overview*
- Chapter 2, *Cellular Radiotelecommunications Intersystem Operations: Intersystem Handoff Information Flows*
- Chapter 3, *Cellular Radiotelecommunications Intersystem Operations: Automatic Roaming Information Flows*
- Chapter 4, *Cellular Radiotelecommunications Intersystem Operations: Operations, Administration, and Maintenance Information Flows and Procedures*
- Chapter 5, *Cellular Radiotelecommunications Intersystem Operations: Signaling Protocols*
- Chapter 6, *Cellular Radiotelecommunications Intersystem Operations: Signaling Procedures*

This edition of the Standard replaces *IS-41-C* which differs from the previous edition (i.e., *IS-41-B*) in its support of the following functionality:

- Intersystem Authentication and Encryption (supersedes *TSB51*)
- Intersystem Operations for Dual-mode CDMA Terminals (supersedes *TSB64*)
- Border Cell Problem Resolution (supersedes *TSB65*)
- Expanded Feature Support (i.e., for features defined in *TIA/EIA-664*)
- Technical Clarifications and Compatibility (as per *TSB41* and *TSB55*)

REVISION HISTORY

Revision	Date	Remarks
<i>(IS-41) 0</i>	February 1988	Initial publication
<i>(IS-41) A</i>	January 1991	
<i>(IS-41) B</i>	December 1991	
<i>(IS-41) C</i>	February 1996	
D	December 1997	Initial ANSI publication

NOTE

The numbering system of this series of Standards varies from normal TIA/EIA practice. The unique numbering system assigned to these documents is intended to reflect their hierarchical structure.

1
2
3
4
5
6
7
8
9
10
11
12
13
14
15
16
17
18
19
20
21
22
23
24
25
26
27
28
29
30
31
32
33
34
35
36
37
38
39
40
41
42
43
44
45
46
47
48
49
50
51
52
53
54
55
56
57
58
59
60

1 INTRODUCTION

1.1 OBJECTIVE

The purpose of this document is to identify those cellular services which require intersystem cooperation, to present the general background against which those services are to be provided, and to summarize the principal considerations which have governed and directed the particular approaches taken in the procedural recommendations.

1.2 SCOPE

This document defines the range of application of the current issue of the series. It focuses on overall objectives and basic assumptions. Procedural details are presented in the other recommendations.

1.3 ORGANIZATION

This document is organized as follows:

- Sections 2, 3, and 4 entitled “References”, “Definitions” and “Symbols and Abbreviations” respectively provide a referral to terminology and acronyms used in this document.
- Section 5 entitled “Network Reference Model” presents the functional entities and the associated interface reference points of a cellular network.
- Section 6 entitled “Cellular Intersystem Services”, identifies the services addressed by this standard.
- Section 7 entitled “General Background and Assumptions”, identifies the general background and assumptions under which the procedures for providing the identified services are designed to operate.
- Section 8 entitled “Restrictions” defines special restrictions applicable to the current issue of this standard.

2 REFERENCES

2.1 NORMATIVE REFERENCES

CCITT 1984 (Red Book) Versions of:

- *X.25 Interface Between DTE And DCE For Terminals Operating In The Packet Mode And Connected To Public Data Networks By Dedicated Circuit*
- *X.200 Series of Documents*

(Blue Book) Versions of:

- *Q.700 Introduction to CCITT Signalling System No. 7*
- *Q.701 Functional description of the message transfer part (MTP) of signalling system No. 7*
- *Q.702 Signalling data link*
- *Q.703 Signalling link*
- *Q.704 Signalling network functions and messages*
- *Q.705 Signalling network structure*
- *Q.706 Message transfer part signalling performance*
- *Q.707 Testing and maintenance*
- *Q.708 Numbering of international signalling point codes*
- *Q.709 Hypothetical signalling reference connection*
- *Q.710 Simplified MTP version for small systems*
- *Q.711 Functional description of the signalling connection control part.*
- *Q.712 Definition and function of SCCP messages.*
- *Q.713 SCCP formats and codes*
- *Q.714 Signalling connection control part procedures*
- *Q.716 Signalling connection control part (SCCP) performances*

ISO:

- *ISO-7776 X.25 LAPB Compatible DTE Data Link Procedures*
- *ISO-8208 X.25 Packet Level Protocol for Data Terminal Equipment*
- *ISO-8878 Use Of X.25 To Provide The OSI Connection-Mode Network Service*

1
2
3
4
5
6
7
8 #
9
10 #
11 #
12 #
13
14
15
16 #
17
18 #
19 #
20 #
21 #
22 #
23
24 #
25
26 #
27
28 #
29 #
30
31 #
32
33 #
34
35 #
36 #
37
38 #
39
40 #
41 #
42 #
43 #
44 #
45 #
46
47
48
49 #
50 #
51 #
52 #
53
54 #
55
56
57
58
59
60

1 CCITT 1988:

- 2 • *T.50 International Reference Alphabet (IRA) formerly Alphabet No. 5 (or IA5)* #

6 ANSI T1 Standards:

- 7 • *ANSI T1.111-1988 Signaling System Number 7 - Message Transfer Part (MTP)* #
- 8 • *ANSI T1.112-1988 Signaling System Number 7 - Signaling Connection Control* #
- 9 • *Part (SCCP)* #
- 10 • *ANSI T1.114-1988 Signaling System Number 7 - Transaction Capabilities* #
- 11 • *Application Part (TCAP)* #
- 12 • *ANSI T1.611-1991 Signaling System Number 7 (SS7) - Supplementary Services for* #
- 13 • *Non-ISDN-Subscribers; American National Standards Institute, Inc.; 1991* #
- 14 • *ANSI T1.209-1989 Operations, Administration, Maintenance, and Provisioning* #
- 15 • *(OAM&P) - Network Tones and Announcements; American National Standards* #
- 16 • *Institute, Inc.; 1989* #

23 TIA/EIA:

- 24 • *ANSI/TIA/EIA-660 Uniform Dialing Procedures and Call Processing Treatment* #
- 25 • *for Cellular Radio Telecommunications; Telecommunications Industry* #
- 26 • *Association; July 1996* #
- 27 • *ANSI/TIA/EIA-664 Cellular Features Description; Telecommunications Industry* #
- 28 • *Association; June 1996* #
- 29 • *TIA/EIA/IS-93 Cellular Radio Telecommunications Ai - Di Interfaces Standard;* #
- 30 • *Telecommunications Industry Association; December 1993* #

36 AMPS:

- 37 • *ANSI/EIA/TIA-553 Mobile Station - Land Station Compatibility Specification;* #
- 38 • *September 1989* #

42 CDMA:

- 43 • *TIA/EIA/IS-95-A Mobile Station Base Station Compatibility Standard for Dual-* #
- 44 • *Mode Wideband Spread Spectrum Cellular System; Telecommunications Industry* #
- 45 • *Association; May 1995* #
- 46 • *TIA/EIA/IS-97 Recommended Minimum Performance Standards for Base Stations* #
- 47 • *Supporting Dual-Mode Wideband Spread Spectrum Cellular Mobile Stations;* #
- 48 • *Telecommunications Industry Association; December 1994* #
- 49 • *TIA/EIA/IS-637 Short Message Services for Wideband Spread Spectrum Cellular* #
- 50 • *System; Telecommunications Industry Association; December 1995* #

DMH:

- *TIA/EIA/IS-124 Cellular Radio Telecommunications Intersystem Non-Signaling Data Communications (DMH)*; Telecommunications Industry Association; November 1993

NAMPS:

- *TIA/EIA/IS-88 Mobile Station - Land Station Compatibility Standard for Dual-Mode Narrow Band Analog Cellular Technology*; Telecommunications Industry Association; February 1993
- *TIA/EIA/IS-91 Mobile Station - Base Station Compatibility Standard for 800 MHz Analog Cellular*; Telecommunications Industry Association; October 1994

TDMA:

- *TIA/EIA/IS-54-B Cellular System Dual -Mode Mobile Station - Base Station Compatibility Standard*; Telecommunications Industry Association; April 1992.
- *TIA/EIA/IS-136 800MHz TDMA Cellular - Radio Interface - Mobile Station Base Station Compatibility Standard*; Telecommunications Industry Association; December 1994.

2.2 INFORMATIVE REFERENCES

NoLECN:

- *SR-TSV-002275 Notes on the LEC Networks*; Bell Communications Research, Inc.; April 1994.

N-ISDN:

- *TR-NWT-000776 Network Interface Description for National ISDN-1 Customer Access*; Bell Communications Research, Inc.; August 1993.

1 #
 2 #
 3 #
 4 #
 5 #
 6 #
 7 #
 8 #
 9 #
 10 #
 11 #
 12 #
 13 #
 14 #
 15 #
 16 #
 17 #
 18 #
 19 #
 20 #
 21 #
 22 #
 23 #
 24 #
 25 #
 26 #
 27 #
 28 #
 29 #
 30 #
 31 #
 32 #
 33 #
 34 #
 35 #
 36 #
 37 #
 38 #
 39 #
 40 #
 41 #
 42 #
 43 #
 44 #
 45 #
 46 #
 47 #
 48 #
 49 #
 50 #
 51 #
 52 #
 53 #
 54 #
 55 #
 56 #
 57 #
 58 #
 59 #
 60 #

3 DEFINITIONS and DOCUMENTATION CONVENTIONS

3.1 DEFINITIONS

Active

The MS is available for call delivery. This state is maintained by the MSC, the VLR and the HLR. (See also Available, Inactive and Unavailable.)

Access Denial Call Treatment

A tone, announcement, or call redirection applied as appropriate.

Adjunct MSC

A Mobile Switching Center (MSC) that is providing adjunct services such as voice response, voice recognition, DTMF tone detection, voice message storage, etc.

Anchor MSC

The Mobile Switching Center (MSC), that is the first to assign a traffic channel to a call on origination or termination is called the Anchor MSC. For the duration of this call, this MSC shall be the anchor (fixed) point in the event that the Mobile Station (MS) should be handed off to other MSCs.

Available

The MS can accept a call delivery (i.e., the MS is in a known location and it is in a state able to accept call deliveries). The availability of a MS to accept a call delivery is maintained only by the MSC. (See also Active, Inactive and Unavailable.)

Call Delivery

The process by which calls directed to the cellular subscriber are delivered to the subscriber while roaming in a visited system.

Call Delivery Method

Method by which a call is delivered to a subscriber in MSC-V.

Call Disconnect

The process of requesting the release of a connection between two or more network addresses.

Call Release

The process of relinquishing the facilities and circuits used for a call.

Call Termination

The process of connecting a subscriber to an incoming call.

Candidate MSC

This term is used during the handoff measurement request by the current serving MSC to reference the MSC that is being requested to provide its best CELL ID and SIGNAL QUALITY values.

Cell Site

The physical location of a cell's radio equipment and supporting systems. This term is also used to refer to the equipment located at the cell site.

Clearinghouse

A service used for the exchange and management of information.

Data Communications

The digital transmission of information (other than voice).

Dialogue

A user interaction sequence composed of tones and announcements that may gather information.

Gateway MSC

See MSC-G.

Home Location Register (HLR)

See 5.1.4

1
2
3
4
5
6
7
8
9
10
11
12
13
14
15
16
17
18
19
20
21
22
23
24
25
26
27
28
29
30
31
32
33
34
35
36
37
38
39
40
41
42
43
44
45
46
47
48
49
50
51
52
53
54
55
56
57
58
59
60

Home System

The system which is transmitting the System Identifier (SID) (refer to *EIA/TIA-553*) which is recognized by the MS as the “Home” SID.

Inactive

The MS is not available for call delivery. The MS may not be registered. The MS may be registered, but is out of radio contact (e.g., missing autonomous registrations) or is intentionally inaccessible for periods of time (e.g., slotted mode, paging frame class, or sleep mode). An inactive MS may accept SMS message deliveries. This state is maintained by the MSC, the VLR and the HLR. (See also Active, Available, and Unavailable.)

Market Identification (MarketID)

A unique market identifier that is specified by the service provider (e.g., FCC assigned SID, CIBERNET assigned BID - see *TIA/EIA TSB29*).

Mobile Assisted Handoff (MAHO)

A process where handoff measurements are done by the MS under the control of the MSC and Base Station. The MSC and Base Station retain the control over when the handoff actually occurs.

Mobile Station (MS)

See 5.1.7

Mobile Switching Center (MSC)

See 5.1.8

MSC-G

An MSC that is capable of the Intersystem procedures, defined in this document, between entities in the network reference model so as to provide service.

MSC-H

The “home” MSC of an MS which is broadcasting the SID that is recorded in the MS’s Security and Identification memory, and to which the MS’s Directory Number is assigned.

MSC-V

A “visited” MSC in whose service area a roamer is operating.

Network Reference Model

The functional entities and the associated interface reference points that may logically comprise a cellular network. (See 5.)

Originating MSC

The MSC-H or MSC-G that initiates the call delivery procedures defined in this document.

Originating SMS supplementary service

Services or features that affect SMS message originations and are requested on a per message basis as supported by a particular teleservice, for example, delayed delivery, or message distribution to a list of destinations.

Protocol Extension

A mechanism provided to allow systems with a common bilateral agreement to extend the *TIA/EIA-41* protocol. There is a range of reserved Error Codes, Operation Codes, Parameter Identifiers (in addition to PRIVATE Parameter Identifiers), and ranges of values in enumerated parameter types and data fields. The only mechanism to resolve conflicting uses of protocol extension is to standardize their usage. The Protocol Extension mechanism is used at the risk of the implementation. Protocol Extensions should not be used unless the message recipient is known to support them.

Registered

The HLR has a pointer to a system serving an MS. A registered MS may be active or inactive.

Registration

The procedure by which a MS becomes listed as being present in the service area of an MSC.

Remote Feature Control Port (RFC Port)

A terminating directory number supporting service profile modification.

Roamer Port

A terminating directory number supporting call delivery to mobile stations.

Roamer Service Profile

The specific set of features, capabilities and/or operating restrictions, other than financial accountability, associated with the subscriber.

Roamer Validation

That aspect of roamer service qualification dealing with financial accountability. Also, the general procedure by which a roamer's financial accountability is established.

Service Qualification

The service capabilities, features and privileges to which an MS is entitled. Also, the general procedure by which such service capabilities, features, and privileges become established in an MSC.

Serving MSC

The MSC which currently has the MS obtaining service at one of its cell sites within its coverage area.

Signaling

The information exchanged between the mobile station and the network, or within the network, for the purposes of service provision (e.g., connection establishment).

Switch Number (SWNO)

A number uniquely identifying a particular switch (i.e., a group of cell sites and the associated switch resources) within a group of switches associated with a common MarketID.

Target MSC

The MSC which was selected from the candidate list as having the cell site with the best signal quality value for the MS during the location request function.

Temporary Local Directory Number (TLDN)

A network address temporarily assigned for call setup.

Terminating SMS supplementary service

Services or features that affect SMS message terminations, for example, screening, forwarding, delivery to an MS, delayed delivery while roaming, or distribution to a group based upon a destination address.

Termination Address

One or more digits, as determined by the Home System, which identify the Terminating Party. This could include Speed Call Codes (when supported by the Home Service Provider), other Mobile Telephone Numbers or any valid World Telephone Number.

Traffic

The information generated by the subscriber that is transported on the network (i.e. user voice or data).

Unavailable

The MS cannot accept a normal call delivery (i.e., the MS is in an unknown location or it is in a state unable to accept call deliveries). The availability of an MS to accept a call delivery is maintained only by the MSC. (See also Active, Available, and Inactive.)

Unregistered

A state where the MS is unavailable for any type of termination event and the HLR pointer is not directed to any visited system.

Visited System

From the MS's perspective, a system which is transmitting a SID which is not recognized by the MS as the "Home" SID. From a network perspective, the system in which an MS is currently registered.

Visitor Location Register (VLR)

See 5.1.11

1
2
3
4
5
6
7
8
9
10
11
12
13
14
15
16
17
18
19
20
21
22
23
24
25
26
27
28
29
30
31
32
33
34
35
36
37
38
39
40
41
42
43
44
45
46
47
48
49
50
51
52
53
54
55
56
57
58
59
60

3.2 DOCUMENTATION CONVENTIONS

Each scenario description has two components:

- a scenario diagram, followed by
- a description of each step in the scenario diagram.

Each of these two components employs a set of documentation conventions, described in Sections 3.2.1 and 3.2.2.

3.2.1 Scenario Diagram Conventions

The scenarios presented in this document use the following diagrammatic conventions to illustrate the information exchange between network entities:

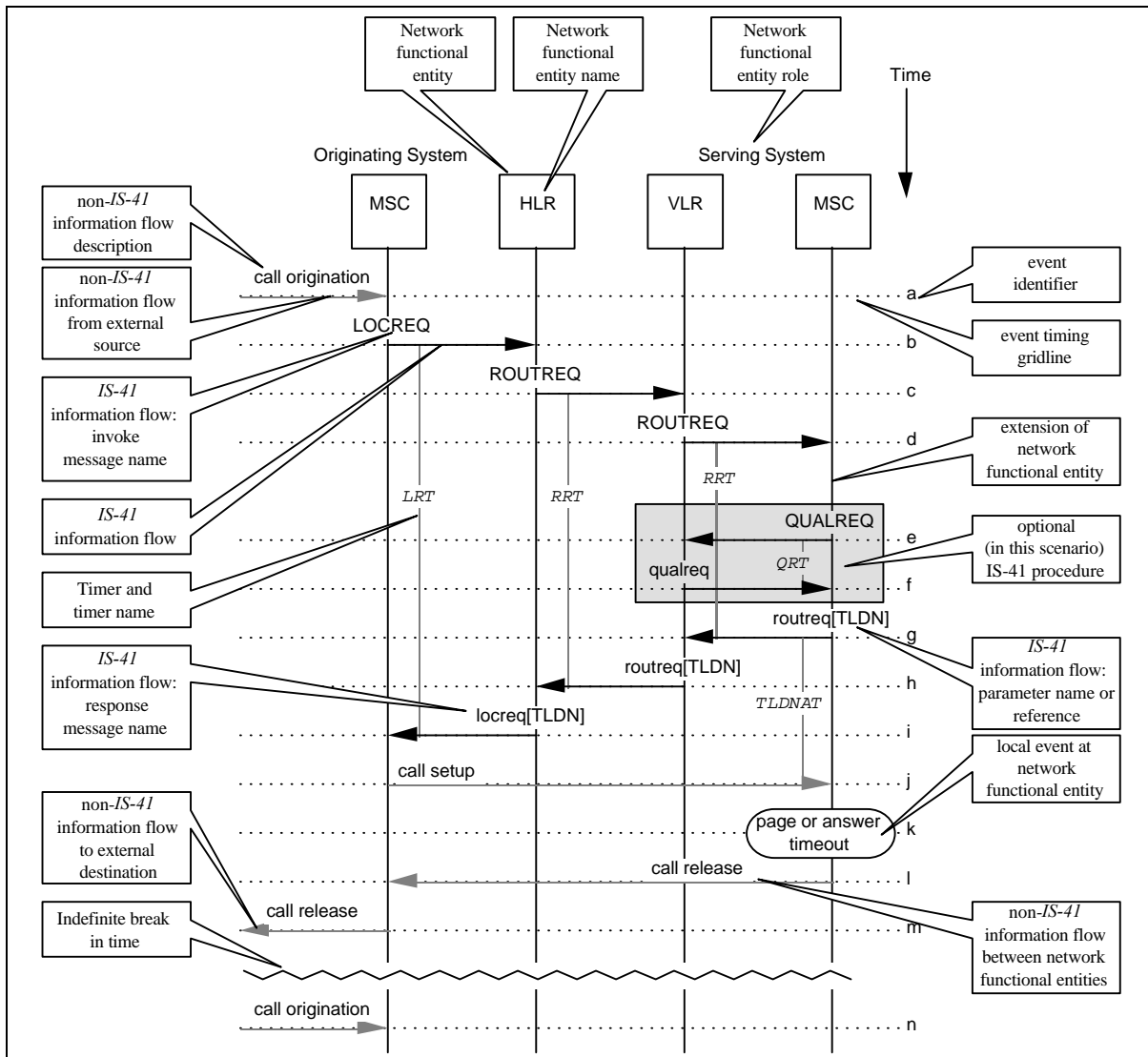

Figure 1 Diagrammatic Conventions

The following items should be noted in figure 1:

1. Every event identifier must have an associated information flow.
2. Information flows are classified as either *TIA/EIA-41* or non-*TIA/EIA41*; the former are subject to standardization in this document, while the latter are not.
3. Only functional entities which are involved in an information flow (i.e., source, destination, or tandem) are shown.
4. Use of parameter references, rather than the parameter names themselves, is permitted (e.g., TLDN rather than Digits (Destination)) where this is deemed to improve readability. However, the mapping of references to actual parameters must be provided.
5. An *TIA/EIA-41* operation's INVOKE component is designated by an upper-case acronym (e.g., LOCREQ); its RETURN RESULT is designated by a lower-case acronym (e.g., locreq); its RETURN ERROR is designated by the full name (e.g., LocationRequest RETURN ERROR).
6. Optional *TIA/EIA-41* operations are enclosed by shaded areas. See events "e" and "f".

3.2.2 Scenario Description Conventions

The scenario descriptions presented in this document use the following conventions:

1. Each event identifier (or *step*) in a scenario diagram has an accompanying text description of the information flow involved.
2. Scenario steps which involve a *TIA/EIA-41* information flow are followed by a tabular listing of the parameters included in the operation component; e.g.:
 - c. The HLR determines that authorization can be granted to the MS and returns this indication to the Serving VLR in the `qualreq`.

Parameters	Usage	Type
AUTHPER	Authorization confirmed indication with period of authorization.	R
Profile: [CFI]	Subscriber's profile information: Authorization and activity states for features.	R
[ORIGIND]	Type of calls MS is allowed to originate.	O
[TERMRES]	Type of calls MS is allowed to terminate.	O
HLRID [MSCID]	HLR MSCID to key MS record against for UnreliableRoamerDataDirective.	R
MYTYP	HLR vendor identification.	MBC

The following items from the table should be noted:

- When a more descriptive reference is used for one or more *TIA/EIA-41* parameters (e.g., HLRID vs. MSCID and Profile vs. the three *TIA/EIA-41* parameters listed), the *TIA/EIA-41* parameter(s), in square brackets, follows the reference. The reference is used in the scenario figure.
 - The Type refers to whether the parameter is Required (R) *for the scenario*, Optional (O) *for the scenario*, or Mandatory for Backward Compatibility (MBC). MBC identifies a parameter that is not used for the scenario but mandatory based on backward compatibility with previous versions of *TIA/EIA-41*.
3. Scenario steps which involve a *TIA/EIA-41* information flow are followed by a tabular listing of the *additional* parameters included in the operation component; e.g.:
- c. The HLR detects the authorized CNIR request and sends a `featreq` to the Serving MSC. The `featreq` includes the OneTimeFeatureIndicator (OTFI).

Additional Parameters	Usage	Type
OTFI	Modify CNIR feature processing for the duration of this call originated by MS.	R

Additionally, if a more descriptive reference for one or more parameters is used in these sections, a table like those in Section 4 is provided to explain the use of the reference.

4. The following notation convention is used:
- When referring to an operation, the operation name is used (e.g., AuthenticationDirective).
 - When referring to the operation's INVOKE component, the uppercase acronym is used (e.g., AUTHDIR).
 - When referring to the operation's RETURN RESULT component, the lowercase acronym is used (e.g., authdir).
 - When referring to the operation's RETURN ERROR component, the full name of the operation is used (e.g., AuthenticationDirective RETURN ERROR).

4 SYMBOLS AND ABBREVIATIONS

3WC	Three Way Calling	1
A/D	Analog to Digital	2
AAV	AuthenticationAlgorithmVersion parameter	3
ABDGTS	DMH_AlternateBillingDigits parameter	4
AC	Authentication Center	5
ACCDEN	AccessDeniedReason parameter	6
ACDGTS	DMH_AccountCodeDigits parameter	7
ACK	Positive Acknowledgment Signal	8
ACSE	Association Control Service Element	9
ACT	<i>Active</i>	10
ACTCODE	ActionCode parameter	11
ADFT	Authentication Directive Forward Timer	12
ADT	Authentication Directive Timer	13
AE	Application Entity	14
AFREPORT	AuthenticationFailureReport INVOKE	15
afreport	AuthenticationFailureReport RETURN RESULT	16
AFRT	Authentication Failure Report Timer	17
ALERTIME	AlertTime parameter	18
ALRTCODE	AlertCode parameter	19
ALRTRES	AlertResult parameter	20
AMPS	Advanced Mobile Phone System	21
ANNCODE	AnnouncementCode parameter	22
ANNLIST	AnnouncementList parameter	23
ANSI	American National Standards Institute	24
APDU	Application Protocol Data Unit	25
ART	Authentication Request Timer	26
ASE	Application Service Element	27
ASN.1	Abstract Syntax Notation One	28
ASP	Application Service Part	29
ASREPORT	AuthenticationStatusReport INVOKE	30
asreport	AuthenticationStatusReport RETURN RESULT	31
ASRRT	Authentication Status Report Response Timer	32
ASRT	Authentication Status Report Timer	33
ATIS	Alliance for Telecommunications Industry Solutions	34
AUTH	Authentication Indicator	35
AUTHBS	AuthenticationResponseBaseStation parameter	36
AUTHCAP	AuthenticationCapability parameter	37
AUTHDATA	AuthenticationData parameter	38
AUTHDEN	AuthorizationDenied parameter	39
AUTHDIR	AuthenticationDirective INVOKE	40
authdir	AuthenticationDirective RETURN RESULT	41
AUTHDIRFWD	AuthenticationDirectiveForward INVOKE	42
authdirfwd	AuthenticationDirectiveForward RETURN RESULT	43
AUTHPER	AuthorizationPeriod parameter	44

1	AUTHR	AuthenticationResponse parameter
2	AUTHREQ	AuthenticationRequest INVOKE
3	authreq	AuthenticationRequest RETURN RESULT
4	AUTHU	AuthenticationResponseUniqueChallenge parameter
5	AVTYP	AvailabilityType parameter
6	BCD	Binary Coded Decimal
7	BDT	Bulk Deregistration Timer
8	BER	Basic Encoding Rules
9	BID	Billing System Identifier
10	BILLDGTS	DMH_BillingDigits parameter
11	BILLID	BillingID parameter
12	BLKT	Blocking Timer
13	BLOCKING	Blocking INVOKE
14	BORDACC	BorderCellAccess parameter
15	BS	Base Station
16	BSCHALL	BaseStationChallenge INVOKE
17	bschall	BaseStationChallenge RETURN RESULT
18	BSCT	Base Station Challenge Timer
19	BULKDEREG	BulkDeregistration INVOKE
20	bulkdereg	BulkDeregistration RETURN RESULT
21	CANDEN	CancellationDenied parameter
22	CANTYP	CancellationType parameter
23	CARDGTS	CarrierDigits parameter
24	CAVE	Cellular Authentication and Voice Encryption
25	CC	Conference Calling
26	CCDATA	ControlChannelData parameter
27	CCI	ConferenceCallingIndicator parameter
28	CCITT	International Telegraph and Telephone Consultative Committee
29	CCS7	Common Channel Signaling 7
30	CD	Call Delivery
31	CDEN	ConditionallyDeniedReason parameter
32	CDMA	Code Division Multiple Access
33	CDMACHAN	CDMACodeChannel parameter
34	CDMACHINFO	CDMACodeChannelInformation parameter
35	CDMACHLIST	CDMACodeChannelList parameter
36	CDMADATA	CDMAChannelData parameter
37	CDMAMAHO	CDMATargetMAHOInformation parameter
38	CDMAMAHOLIST	CDMATargetMAHOList parameter
39	CDMAMEAS	CDMATargetMeasurementInformation parameter
40	CDMAMEASLIST	CDMATargetMeasurementList parameter
41	CDMAMODE	CDMACallMode parameter
42	CDMAMPR	CDMAMobileProtocolRevision parameter
43	CDMAPILOT	CDMAPilotStrength parameter
44	CDMAPLCM	CDMAPrivateLongCodeMask parameter
45	CDMAQUAL	CDMASignalQuality parameter
46	CDMASC	CDMASlotCycleIndex parameter
47	CDMASC	CDMASlotCycleIndex parameter
48	CDMASC	CDMASlotCycleIndex parameter
49	CDMASC	CDMASlotCycleIndex parameter
50	CDMASC	CDMASlotCycleIndex parameter
51	CDMASC	CDMASlotCycleIndex parameter
52	CDMASC	CDMASlotCycleIndex parameter
53	CDMASC	CDMASlotCycleIndex parameter
54	CDMASC	CDMASlotCycleIndex parameter
55	CDMASC	CDMASlotCycleIndex parameter
56	CDMASC	CDMASlotCycleIndex parameter
57	CDMASC	CDMASlotCycleIndex parameter
58	CDMASC	CDMASlotCycleIndex parameter
59	CDMASC	CDMASlotCycleIndex parameter
60	CDMASC	CDMASlotCycleIndex parameter

CDMASOWD	CDMAServingOneWayDelay parameter	1
CDMASWIN	CDMASearchWindow parameter	2
CDMATOWD	CDMATargetOneWayDelay parameter	3
CDRT	Call Data Request Timer	4
CFB	Call Forwarding—Busy	5
CFD	Call Forwarding—Default	6
CFI	CallingFeaturesIndicator parameter	7
CFNA	Call Forwarding—No Answer	8
CFU	Call Forwarding—Unconditional	9
CGSA	Cellular Geographical Service Area	10
CHDATA	ChannelData parameter	11
CHNO	Channel Number	12
CMAC	Control Mobile Attenuation Code	13
CMODES	ConfidentialityModes parameter	14
CNI	Calling Number Identification	15
CNIP	Calling Number Identification Presentation	16
CNIR	Calling Number Identification Restriction	17
COUNT	CallHistoryCount parameter	18
COUNTEx	CallHistoryCountExpected parameter	19
COUNTREQ	CountRequest INVOKE	20
countreq	CountRequest RETURN RESULT	21
COUNTRPT	CountUpdateReport parameter	22
CPNDGTS1	CallingPartyNumberDigits1 parameter	23
CPNDGTS2	CallingPartyNumberDigits2 parameter	24
CPNSTRG1	CallingPartyNumberString1 parameter	25
CPNSTRG2	CallingPartyNumberString2 parameter	26
CPSUB	CallingPartySubaddress parameter	27
CRT	Count Request Timer	28
CT	Call Transfer	29
CTT	Clear Trunk Timer	30
CW	Call Waiting	31
DCC	Digital Color Code	32
DCE	Data Circuit-Terminating Equipment	33
DENACC	DenyAccess parameter	34
DENAUTHPER	DeniedAuthorizationPeriod parameter	35
DEREG	DeregistrationType parameter	36
DGTCC	DigitCollectionControl parameter	37
DGTSDIAL	Digits Dialed	38
DMAC	Digital Mobile Attenuation Code	39
DMH	Data Message Handling	40
DN	Directory Number	41
DND	Do Not Disturb	42
DPC	Destination Point Code	43
DTE	Data Terminating Equipment	44
DVCC	Digital Verification Color Code	45
DXE	Data Terminating or Data Circuit-Terminating Equipment	46
ECSA	Exchange Carrier Standards Association	47
		48
		49
		50
		51
		52
		53
		54
		55
		56
		57
		58
		59
		60

1	EIA	Electronic Industries Association
2	EIR	Equipment Identity Register
3	ERP	Effective Radiated Power
4	ESN	ElectronicSerialNumber parameter
5	EXTMSCID	ExtendedMSCID parameter
6	EXTMYTYP	ExtendedSystemMyTypeCode parameter
7	FA	Flexible Alerting
8	FACDIR	FacilitiesDirective or FacilitiesDirective2 INVOKE
9	facdir	FacilitiesDirective or FacilitiesDirective2 RETURN RESULT
10	FACDIR2	FacilitiesDirective2 INVOKE
11	facdir2	FacilitiesDirective2 RETURN RESULT
12	FACREL	FacilitiesRelease INVOKE
13	facrel	FacilitiesRelease RETURN RESULT
14	FC	Feature Code
15	FE	Functional Entity
16	FEATRESULT	FeatureResult parameter
17	FEATREQ	FeatureRequest INVOKE
18	featreq	FeatureRequest RETURN RESULT
19	FLASHREQ	FlashRequest INVOKE
20	flashreq	FlashRequest RETURN RESULT
21	FRRT	Feature Request Response Timer
22	FRT	Flash Request Timer
23	FU	Functional Unit
24	GEOAUTH	GeographicAuthorization parameter
25	GRPINFO	GroupInformation parameter
26	GSL	Global Service Logic
27	GTT	Global Title Translation
28	HANDBACK	HandoffBack INVOKE
29	handback	HandoffBack RETURN RESULT
30	HANDBACK2	HandoffBack2 INVOKE
31	handback2	HandoffBack2 RETURN RESULT
32	HANDMREQ	HandoffMeasurementRequest INVOKE
33	handmreq	HandoffMeasurementRequest RETURN RESULT
34	HANDMREQ2	HandoffMeasurementRequest2 INVOKE
35	handmreq2	HandoffMeasurementRequest2 RETURN RESULT
36	HANDREASON	HandoffReason parameter
37	HANDTHIRD	HandoffToThird INVOKE
38	handthird	HandoffToThird RETURN RESULT
39	HANDTHIRD2	HandoffToThird2 INVOKE
40	handthird2	HandoffToThird2 RETURN RESULT
41	HLR	Home Location Register
42	HLRID	Home Location Register Identification
43	HLRINFO	HLRInformation parameter
44	HOSTATE	HandoffState parameter
45	HOT	Handoff Order Timer
46	HTTRT	Handoff To Third Result Timer
47	HTTT	Handoff To Third Timer
48		
49		
50		
51		
52		
53		
54		
55		
56		
57		
58		
59		
60		

IA5	International Alphabet 5; see CCITT <i>Rec. T.50</i>	1
IAM	Initial Address Message	2
IDT	Information Directive Timer	3
IFT	Information Forward Timer	4
IMSCCID	InterMSCircuitIdentification parameter	6
INFODIR	InformationDirective INVOKE	7
infodir	InformationDirective RETURN RESULT	9
INFOFWD	InformationForward INVOKE	10
infofwd	InformationForward RETURN RESULT	11
IP	Internet Protocol	12
ISANSWER	InterSystemAnswer INVOKE	13
isanswer	InterSystemAnswer RETURN RESULT	14
ISART	InterSystemAnswer Response Timer	15
ISAT	InterSystemAnswer Timer	16
ISCOUNT	InterSwitchCount parameter	17
ISDN	Integrated Services Digital Network	18
ISO	International Standards Organization	19
ISPAGE	InterSystemPage INVOKE	20
ispage	InterSystemPage RETURN RESULT	21
ISPAGE2	InterSystemPage2 INVOKE	22
ispage2	InterSystemPage2 RETURN RESULT	23
ISPR	InterSystemPage Request Timer	24
ISSETUP	InterSystemSetup INVOKE	25
issetup	InterSystemSetup RETURN RESULT	26
ISSRT	InterSystemSetup Request Timer	27
ISSWT	InterSystemSetup Wait Timer	28
ISTERM	IntersystemTermination parameter	29
ISUP	ISDN User Part	30
LATA	Local Access and Transport Area	31
LB	<i>Locally Blocked</i>	32
LEGINFO	LegInformation parameter	33
LMMRT	Location Measurement Maximum Response Timer	34
LOCID	LocationAreaID parameter	35
LOCREQ	LocationRequest INVOKE	36
locreq	LocationRequest RETURN RESULT	37
LOCTERM	LocalTermination parameter	38
LRB	<i>Locally and Remotely Blocked</i>	39
LRT	Location Request Timer	40
LSB	Least Significant Bit	41
MA	Mobile Application	42
MAH	Mobile Access Hunting	43
MAHO	Mobile Assisted Handoff	44
MAHT	Mobile Access Hunt Timer	45
MAP	Mobile Application Part	46
MAT	Mobile Arrival Timer	47
MAXHANDOFF	MaximumHandoffCount	48
MBC	Mandatory for Backward Compatibility	49
		50
		51
		52
		53
		54
		55
		56
		57
		58
		59
		60

1	MC	Message Center
2	MDN	MobileDirectoryNumber parameter
3	MHOT	Mobile Handoff Order Timer
4	MHS	Message Handling Systems
5	MIN	Mobile Identification Number
6	MIN1	NXX-XXXX of MIN
7	MIN2	NPA of MIN
8	MS	Mobile Station
9	MSB	Most Significant Bit
10	MSC	Mobile Switching Center
11	MSC-G	Mobile Switching Center—Gateway
12	MSC-H	Mobile Switching Center—Home
13	MSC-V	Mobile Switching Center—Visited
14	MSCID	Mobile Switching Center Identification
15	MSCIN	MSCIdentificationNumber parameter
16	MSINACT	MSInactive INVOKE
17	msinact	MSInactive RETURN RESULT
18	MSIT	MS Inactive Timer
19	MSLOC	MSLocation parameter
20	MSONCH	MobileOnChannel INVOKE
21	MTP	Message Transfer Part
22	MWN	Message Waiting Notification
23	MWNCOUNT	MessageWaitingNotificationCount parameter
24	MWNTYPE	MessageWaitingNotificationType parameter
25	MYTYP	SystemMyTypeCode parameter
26	NACK	Negative Acknowledgment Signal
27	NAMPS	Narrow AMPS
28	NAMPSMODE	NAMPSCallMode parameter
29	NANP	North American Numbering Plan
30	NATIME	NoAnswerTime parameter
31	NCHDATA	NAMPSCchannelData parameter
32	NOSSD	SSDNotShared parameter
33	NPA	Numbering Plan Area (Area Code)
34	NSAP	Network Service Access Point
35	NXX	Office Code
36	OA&M	Operations, Administration, and Maintenance
37	OMT	Overhead Message Train
38	OPC	Originating Point Code
39	OPDU	Operation Protocol Data Unit
40	ORIGIND	OriginationIndicator parameter
41	ORIGTRIG	OriginationTriggers parameter
42	ORREQ	OriginationRequest INVOKE
43	orreq	OriginationRequest RETURN RESULT
44	ORT	Origination Request Timer
45	OSI	Open Systems Interconnection
46	OSSS	Originating SMS Supplementary Service
47	OTFI	OneTimeFeatureIndicator parameter
48		
49		
50		
51		
52		
53		
54		
55		
56		
57		
58		
59		
60		

PACA	Priority Access and Channel Assignment	1
PACAIND	PACAIndicator parameter	2
PAGEIND	PageIndicator parameter	3
PAT	PACA Answer Timer	4
PC	Point Code	5
PCA	Password Call Acceptance	6
PC_SSN	Point Code and Subsystem Number parameter	7
PDN	Public Data Network	8
PDT	PACA Detection Timer	9
PDU	Protocol Data Unit	10
PFT	PACA Feedback Timer	11
PIC	Preferred Interexchange Carrier	12
PILOT	PilotNumber parameter	13
PILOTBID	PilotBillingID parameter	14
PIN	Personal Identification Number	15
PL	Preferred Language	16
PLIND	PreferredLanguageIndicator parameter	17
PN	Pseudo random noise	18
PPDU	Presentation Protocol Data Unit	19
PSTN	Public Switched Telephone Network	20
PSTNTERM	PSTNTermination parameter	21
QDT	Qualification Directive Timer	22
QOS	Quality of Service	23
QRT	Qualification Request Timer	24
QUALCODE	QualificationInformationCode parameter	25
QUALDIR	QualificationDirective INVOKE	26
qualdir	QualificationDirective RETURN RESULT	27
QUALREQ	QualificationRequest INVOKE	28
qualreq	QualificationRequest RETURN RESULT	29
RAND	RandomVariable parameter	30
RANDBS	RandomVariableBaseStation parameter	31
RANDC	RANDC parameter	32
RANDREQ	RandomVariableRequest INVOKE	33
randreq	RandomVariableRequest RETURN RESULT	34
RANDRT	Random Variable Request Timer	35
RANDSSD	RandomVariableSSDUpdate parameter	36
RANDU	RandomVariableUniqueChallenge parameter	37
RANDVT	RANDValidTime parameter	38
RB	<i>Remotely Blocked</i>	39
RCT	Registration Cancellation Timer	40
RDT	Redirection Directive Timer	41
RDRT	Redirection Request Timer	42
Rec.	Recommendation	43
REDDIR	RedirectionDirective INVOKE	44
reddir	RedirectionDirective RETURN RESULT	45
REDIND	DMH_RedirectionIndicator parameter	46
REDREASON	RedirectionReason parameter	47
		48
		49
		50
		51
		52
		53
		54
		55
		56
		57
		58
		59
		60

1	REDREQ	RedirectionRequest INVOKE
2	redreq	RedirectionRequest RETURN RESULT
3	REGCANC	RegistrationCancellation INVOKE
4	regcanc	RegistrationCancellation RETURN RESULT
5	REGNOT	RegistrationNotification INVOKE
6	regnot	RegistrationNotification RETURN RESULT
7	RELREASON	ReleaseReason parameter
8	RESETCKT	ResetCircuit INVOKE
9	resetckt	ResetCircuit RETURN RESULT
10	RF	Radio Frequency
11	RFC	Remote Feature Control
12	RNDGTS	RedirectingNumberDigits parameter
13	RNSTRING	RedirectingNumberString parameter
14	RNT	Registration Notification Timer
15	RO	Remote Operation
16	ROUTDGTS	RoutingDigits parameter
17	ROUTREQ	RoutingRequest INVOKE
18	routreq	RoutingRequest RETURN RESULT
19	RPTTYP	ReportType parameter
20	RRT	Routing Request Timer
21	RSIGQUAL	ReceivedSignalQuality parameter
22	RSSI	Received Signal Strength Indication
23	RSTT	Reset Circuit Timer
24	RSUB	RedirectingSubaddress parameter
25	RUDT	Remote User Interaction Directive Timer
26	RUI	Remote User Interaction
27	RUI-MS	MSC capable of Remote User Interaction
28	RUIDIR	RemoteUserInteractionDirective INVOKE
29	ruidir	RemoteUserInteractionDirective RETURN RESULT
30	SADT	SMS Air Delivery Timer
31	SAOT	SMS Air Origination Timer
32	SAT	Supervisory Audio Tone
33	SBI	Shortened Burst Indicator
34	SBT	SMS Delivery Backward Timer
35	SCA	Selective Call Acceptance
36	SCC	SAT Color Code
37	SCCP	Signaling Connection Control Part
38	SCELLID	ServingCellID parameter
39	SCM	Station Class Mark parameter
40	SDCC	Supplementary Digital Color Code
41	SEIZTYP	SeizureType parameter
42	SENDERIN	SenderIdentificationNumber parameter
43	SETRESULT	SetupResult parameter
44	SFT	SMS Delivery Forward Timer
45	SID	System ID
46	SIGQUAL	Adjusted Signal Quality parameter
47	SMD-ACK	ShortMessageDeliveryAcknowledge message
48		
49		
50		
51		
52		
53		
54		
55		
56		
57		
58		
59		
60		

SMDBACK	SMSDeliveryBackward INVOKE	1	
smdback	SMSDeliveryBackward RETURN RESULT	2	
SMDFWD	SMSDeliveryForward INVOKE	3	
smdfwd	SMSDeliveryForward RETURN RESULT	4	
SMD-NACK	ShortMessageDeliveryNegativeAcknowledge message	5	
SMDPP	SMSDeliveryPointToPoint INVOKE	6	
smdpp	SMSDeliveryPointToPoint RETURN RESULT	7	
SMD-REQ	ShortMessageDeliveryRequest message	8	
SMD-REQUEST	ShortMessageDeliveryRequest message	9	
SME	Short Message Entity	10	
SMEKEY	SignalingMessageEncryptionKey parameter	11	
SMEM	Signaling Message Encryption Mode	12	
SMS	Short Message Service	13	
SMSACCDEN	SMS_AccessDeniedReason parameter	14	
SMSADDR	SMS_Address parameter	15	
SMSDPF	SMS Delivery Pending Flag	16	
SMSMSGCNT	SMS_MessageCount parameter	17	
SMSMWI	SMS_MessageWaitingIndicator parameter	18	
SMSNOTIND	SMS_NotificationIndicator parameter	19	
SMSNOT	SMSNotification INVOKE	20	
smsnot	SMSNotification RETURN RESULT	21	
SMSREQ	SMSRequest INVOKE	22	
smsreq	SMSRequest RETURN RESULT	23	
SMT	Short Message Timer	24	
SNT	SMS Notification Timer	25	
SPDT	Service Profile Directive Timer	26	
SPDU	Session Protocol Data Unit	27	
SPINA	Subscriber PIN Access	28	
SPINI	Subscriber PIN Intercept	29	
SPINIPIN	Subscriber PIN Intercept PIN	30	
SPRT	Service Profile Request Timer	31	
SPT	SMS Point-To-Point Timer	32	
SRT	SMS Request Timer	33	
SS7	Signaling System 7 (ANSI)	34	
	Signaling System No.7 (TTC)	35	*
SSD	SharedSecretData parameter	36	
SSD-A	Shared Secret Data-A	37	
SSD-B	Shared Secret Data-B	38	
SSDURPT	SSDUpdateReport parameter	39	
SSL	Service Specific Logic	40	
SSN	Subsystem Number	41	
STP	Signaling Transfer Point	42	
SWNO	Switch Number	43	
SYSACCDATA	SystemAccessData parameter	44	
SYSACCTYPE	SystemAccessType parameter	45	
SYSCAP	SystemCapabilities parameter	46	
TA	Termination Address	47	
		48	
		49	
		50	
		51	
		52	
		53	
		54	
		55	
		56	
		57	
		58	
		59	
		60	

1	TANDEMDEPTH	Tandem Depth
2	TAT	TerminationAccessType parameter
3	TBCD	Telephony Binary Coded Decimal
4	TC	Transaction Capabilities
5	TCAP	Transaction Capabilities Application Part
6	TCELLID	TargetCellID parameter
7	TDMA	Time Division Multiple Access
8	TDMA	Time Division Multiple Access
9	TDMA	Time Division Multiple Access
10	TDMA	Time Division Multiple Access
11	TDMA	Time Division Multiple Access
12	TDMA	Time Division Multiple Access
13	TDMA	Time Division Multiple Access
14	TDMA	Time Division Multiple Access
15	TDMA	Time Division Multiple Access
16	TDMA	Time Division Multiple Access
17	TDMA	Time Division Multiple Access
18	TDMA	Time Division Multiple Access
19	TDMA	Time Division Multiple Access
20	TDMA	Time Division Multiple Access
21	TDMA	Time Division Multiple Access
22	TDMA	Time Division Multiple Access
23	TDMA	Time Division Multiple Access
24	TDMA	Time Division Multiple Access
25	TDMA	Time Division Multiple Access
26	TDMA	Time Division Multiple Access
27	TDMA	Time Division Multiple Access
28	TDMA	Time Division Multiple Access
29	TDMA	Time Division Multiple Access
30	TDMA	Time Division Multiple Access
31	TDMA	Time Division Multiple Access
32	TDMA	Time Division Multiple Access
33	TDMA	Time Division Multiple Access
34	TDMA	Time Division Multiple Access
35	TDMA	Time Division Multiple Access
36	TDMA	Time Division Multiple Access
37	TDMA	Time Division Multiple Access
38	TDMA	Time Division Multiple Access
39	TDMA	Time Division Multiple Access
40	TDMA	Time Division Multiple Access
41	TDMA	Time Division Multiple Access
42	TDMA	Time Division Multiple Access
43	TDMA	Time Division Multiple Access
44	TDMA	Time Division Multiple Access
45	TDMA	Time Division Multiple Access
46	TDMA	Time Division Multiple Access
47	TDMA	Time Division Multiple Access
48	TDMA	Time Division Multiple Access
49	TDMA	Time Division Multiple Access
50	TDMA	Time Division Multiple Access
51	TDMA	Time Division Multiple Access
52	TDMA	Time Division Multiple Access
53	TDMA	Time Division Multiple Access
54	TDMA	Time Division Multiple Access
55	TDMA	Time Division Multiple Access
56	TDMA	Time Division Multiple Access
57	TDMA	Time Division Multiple Access
58	TDMA	Time Division Multiple Access
59	TDMA	Time Division Multiple Access
60	TDMA	Time Division Multiple Access

VCH	Voice Channel	1
VLR	Visitor Location Register	2
VMAC	Voice Mobile Attenuation Code	3
VMBOX	VoiceMailboxNumber parameter	4
VMN	Voice Mail Number	5
VMR	Voice Message Retrieval	6
VMS	Voice Message System	7
VMSPIN	Voice Mailbox PIN	8
VP	Voice Privacy	9
VPM	Voice Privacy Mode	10
VPMASK	VoicePrivacyMask parameter	11
VRU	Voice Response Unit	12
XXXX	Station Number (in context of NPA-NXX-XXXX)	13
		14
		15
		16
		17
		18
		19
		20
		21
		22
		23
		24
		25
		26
		27
		28
		29
		30
		31
		32
		33
		34
		35
		36
		37
		38
		39
		40
		41
		42
		43
		44
		45
		46
		47
		48
		49
		50
		51
		52
		53
		54
		55
		56
		57
		58
		59
		60

5 NETWORK REFERENCE MODEL

Figure 2 presents the functional entities and the associated interface reference points that may logically comprise a cellular network. The model, as defined herein, is intended to provide a level of abstraction that may facilitate the specification of messages and protocols within *TIA/EIA-41*. As such, implementations may vary with respect to how the functional entities are distributed among various physical units. In cases where functional entities are combined in the same physical equipment the interface reference points become internal, and need not adhere to interface standards.

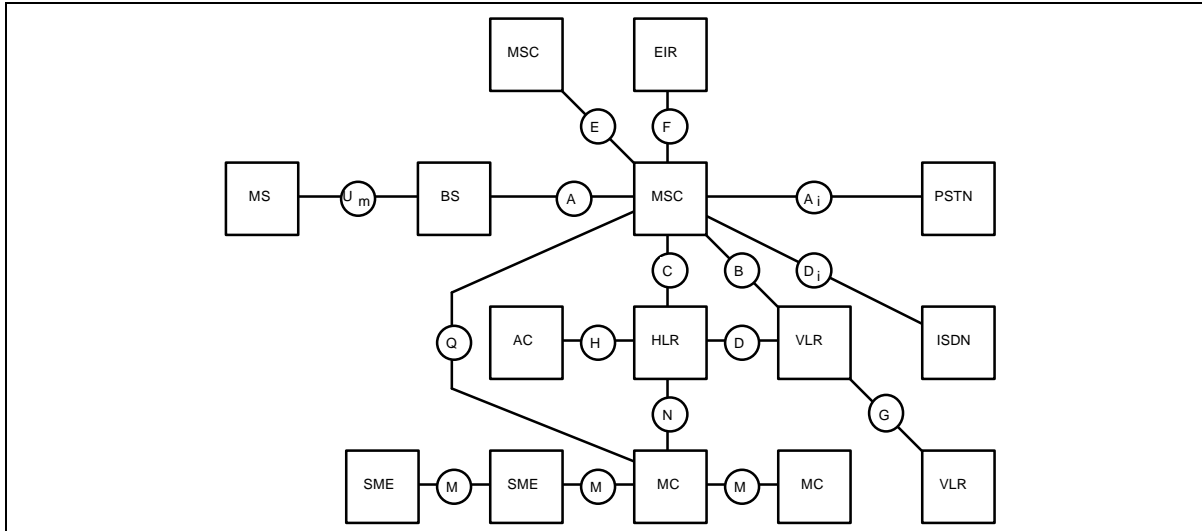

Figure 2 Network Reference Model

Note:

AC	Authentication Center
BS	Base Station
EIR	Equipment Identity Register
HLR	Home Location Register
ISDN	Integrated Services Digital Network
MC	Message Center
MS	Mobile Station
MSC	Mobile Switching Center
PSTN	Public Switched Telephone Network
SME	Short Message Entity
VLR	Visitor Location Register

5.1 FUNCTIONAL ENTITIES

5.1.1 Authentication Center (AC)

The AC is an entity that manages the authentication information related to the MS. The AC may, or may not be located within, and be indistinguishable from an HLR. An AC may serve more than one HLR.

5.1.2 Base Station (BS)

The BS is the common name for all the radio equipment located at one and the same place used for serving one or several cells. The Base Station includes functionality of the Base Station Controller and the Base Station Transceiver systems.

5.1.3 Equipment Identity Register (EIR)

The EIR is the register to which user equipment identity may be assigned for record purposes. The nature, purpose, and utilization of this information is an area for further study. The EIR may, or may not be located within, and be indistinguishable from an MSC.

5.1.4 Home Location Register (HLR)

The HLR is the location register to which a user identity is assigned for record purposes such as subscriber information (e.g. ESN, MDN, Profile Information, Current Location, Authorization Period). The HLR may, or may not be located within, and be indistinguishable from an MSC. The HLR may serve more than one MSC. The HLR may be distributed over more than one physical entity.

5.1.5 Integrated Services Digital Network (ISDN)

The ISDN is defined in accordance with the appropriate Standards.

5.1.6 Message Center (MC)

The MC is an entity that stores and forwards short messages. The MC may also provide supplementary services for Short Message Service.

5.1.7 Mobile Station (MS)

The MS is the interface equipment used to terminate the radio path at the user side. It provides the capabilities to access network services by the user.

5.1.8 Mobile Switching Center (MSC)

The MSC is an automatic system which constitutes the interface for user traffic between the cellular network and other public switched networks, or other MSCs in the same or other cellular networks.

5.1.9 Public Switched Telephone Network (PSTN)

The PSTN is defined in accordance with the appropriate Standards.

5.1.10 Short Message Entity (SME)

The SME is an entity that composes and decomposes short messages. A SME may, or may not be located within, and be indistinguishable from, an HLR, MC, VLR, MS, or MSC.

5.1.11 Visitor Location Register (VLR)

The VLR is the location register other than the HLR used by an MSC to retrieve information for handling of calls to or from a visiting subscriber. The VLR may, or may not be located within, and be indistinguishable from an MSC. The VLR may serve more than one MSC.

5.2 INTERFACE REFERENCE POINTS

5.2.1 Reference Point

Reference Point A is the BS to MSC interface.

5.2.2 Reference Point

Reference Point A_i is the MSC to PSTN interface.

5.2.3 Reference Point

Reference Point B is the MSC to VLR interface.

5.2.4 Reference Point

Reference Point C is the MSC to HLR interface.

5.2.5 Reference Point

Reference Point D is the VLR to HLR interface.

5.2.6 Reference Point

Reference Point D_i is the MSC to ISDN interface.

5.2.7 Reference Point

Reference Point E is the MSC to MSC interface.

5.2.8 Reference Point

Reference Point F is the MSC to EIR interface.

5.2.9 Reference Point

Reference Point G is the VLR to VLR interface.

5.2.10 Reference Point

Reference Point H is the HLR to AC interface.

5.2.11 Reference Point

Reference Point M is the SME to MC interface, the MC to MC interface, and the SME to SME interface.

5.2.12 Reference Point

Reference Point N is the MC to HLR interface.

5.2.13 Reference Point

Reference Point Q is the MC to MSC interface.

5.2.14 Reference Point

Reference Point U_m is the BS to MS interface, which corresponds to the air interface.

5.3 RELEVANT REFERENCE POINTS

For purposes of *TIA/EIA-41* Transactions, the reference points of interest are B, C, D, E, H, M, N, and Q. The remaining reference points are for further study.

1
2
3
4
5
6
7
8
9
10
11
12
13
14
15
16
17
18
19
20
21
22
23
24
25
26
27
28
29
30
31
32
33
34
35
36
37
38
39
40
41
42
43
44
45
46
47
48
49
50
51
52
53
54
55
56
57
58
59
60

5.4 NETWORK ENTITY RELATIONSHIP DIAGRAM

The following figure shows the relationship between network elements identified in the Network Reference Model. The following symbols are used:

a. One-to-Many Relationship

This symbol indicates that entity “A” is associated with exactly one entity of type “B.” Each entity of type “B” is associated with one or more entities of type “A.”

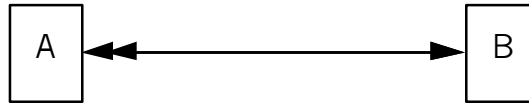

b. One-to-Zero or More Relationship

This symbol indicates that entity “A” is associated with exactly one entity of type “B.” Each entity of type “B” is associated with zero or more entities of type “A.”

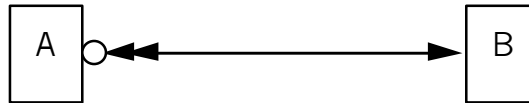

c. Many-to-Many Relationship

All pairs of entities for which a relationship is not shown have a many-to-many relationship (e.g. an HLR may have subscribers registered in many VLRs, and a VLR may be serving subscribers from many HLRs).

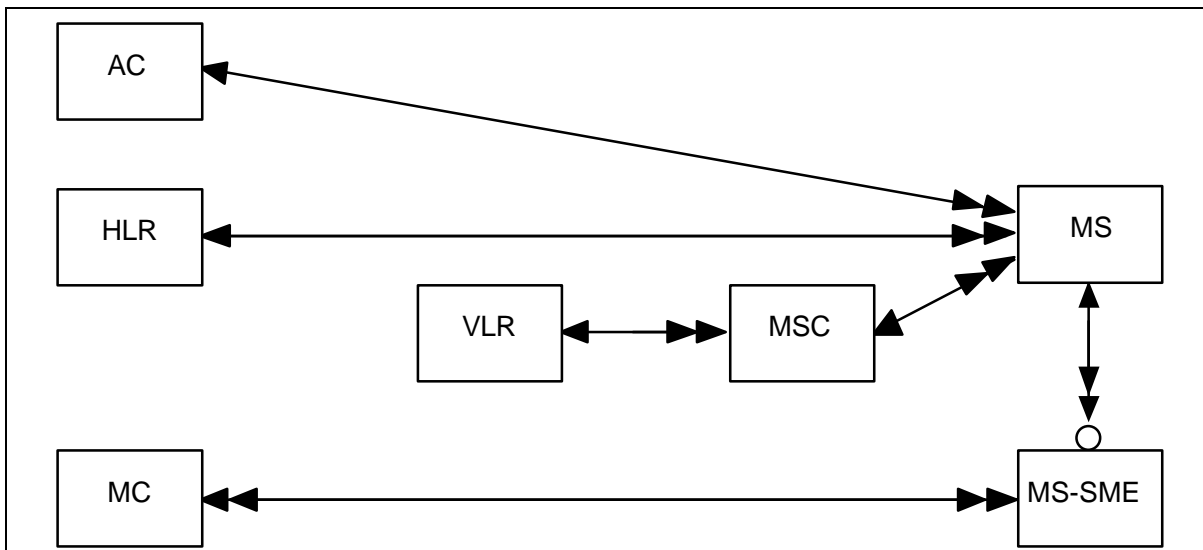

Figure 3 Entity Relationship Diagram

6 CELLULAR INTERSYSTEM SERVICES

This issue of the series addresses two major categories of intersystem services:

1) Intersystem Handoff

Intersystem Handoff refers to the general provisions by which a call in progress on a radio channel under the control of a current serving MSC may be automatically transferred to a different radio channel under the control of another MSC without interruption to the ongoing communication.

2) Automatic Roaming

Automatic Roaming refers to the general provisions for automatically providing cellular services to the MSs which are operating outside their home service area but within the aggregate service area of all participating MSCs. In the most general implementation these include:

- a) Timely identification of the current serving MSC;
- b) Automatic Service Qualification of the roaming MSs, including credit validation, feature privileges, and feature control;
- c) Automatic call delivery to the roaming MSs.

The requirement that the procedures by which these operations are implemented be automatic is implicit in the intent of these recommendations.

1
2
3
4
5
6
7
8
9
10
11
12
13
14
15
16
17
18
19
20
21
22
23
24
25
26
27
28
29
30
31
32
33
34
35
36
37
38
39
40
41
42
43
44
45
46
47
48
49
50
51
52
53
54
55
56
57
58
59
60

7 GENERAL BACKGROUND AND ASSUMPTIONS

#

8 RESTRICTIONS

- 1) Voice facilities for intersystem handoff are restricted to direct dedicated circuits between pairs of participating systems.
- 2) This version does not provide for flow control of data between applications. However, flow control is provided in the data link and network layer portions of this protocol.

1
2
3
4
5
6
7
8
9
10
11
12
13
14
15
16
17
18
19
20
21
22
23
24
25
26
27
28
29
30
31
32
33
34
35
36
37
38
39
40
41
42
43
44
45
46
47
48
49
50
51
52
53
54
55
56
57
58
59
60

1
2
3
4
5
6
7
8
9
10
11
12
13
14
15
16
17
18
19
20
21
22
23
24
25
26
27
28
29
30
31
32
33
34
35
36
37
38
39
40
41
42
43
44
45
46
47
48
49
50
51
52
53
54
55
56
57
58
59
60

INDE

Page numbers are in the format: <chapter number>.<page number>. Page numbers in font are where the indicated item is defined. Page numbers in *Italic* font are references to informative annexes.

Symbols

(not valid) 4-13
 *-9-1-1 5-222, 6-367
 MSC analyze MS dialed number 6-15
 *FC
 HLR analyze MS dialed number 6-19
 *FC0
 HLR analyze MS dialed number 6-19
 *N11
 HLR analyze MS dialed number 6-19
 MSC analyze MS dialed number 6-15
 20 MHz
 StationClassMark
 25 MHz
 StationClassMark
 3WC , , (see Three-Way Calling)
 commanded disconnect 6-39
 in call MS flash attempt 6-14
 other party disconnect 6-39
 RoutingRequest 6-255
 3WC-FA
 CallingFeaturesIndicator
 800 MHz Cellular System
 CDMAChannelData, Band Class
 9-1-1 5-222, 6-367
 MSC analyze MS dialed number 6-15

A

A reference point
 A/D
 AAV , 5-142
 Abandoned Call Leg
 DMH_RedirectionIndicator
 AbbreviatedCongestion
 AnnouncementCode, Tone
 AbbreviatedIntercept

AnnouncementCode, Tone
 ABDGTS , 5-192
 ABNORMAL CONDITIONS 4-20
 AbnormalMobileTermination
 ReleaseReason
 AbnormalSwitchTermination
 ReleaseReason
 Abstract Syntax Notation One 1-14
 AC , 1-24
 ExtendedMSCID, type
 ExtendedSystemMyTypeCode
 PC_SSN, Type
 AC Awaiting AuthenticationStatusReport INVOKE

 AuthenticationDirective 6-43
 AuthenticationFailureReport 6-71
 AuthenticationRequest 6-91
 AuthenticationStatusReport 6-102
 AC Initiating a COUNT Request
 AuthenticationRequest 6-88, 6-89
 AC Initiation of an Authentication Directive
 AC Receiving AuthenticationFailureReport INVOKE

 AC Receiving AuthenticationRequest INVOKE
 AC Receiving BaseStationChallenge INVOKE
 AC Receiving MSInactive INVOKE
 ACCDEN , 3-63, 3-68, 3-78, 3-81, 3-88, 3-134, 3-156, 5-128
 Accepted
 LocationRequest 6-191, 6-192
 Access Denial Call Treatment
 AccessDeniedReason 1-14, 5-119, , 6-310, 6-311, 6-312, 6-343, 6-344, 6-357, 6-358, 6-394
 Busy 6-311, 6-343, 6-346, 6-347, 6-359, 6-360
 FeatureRequest 6-137, 6-138
 InterSystemPage 6-177, 6-179
 InterSystemPage2 6-180, 6-182, 6-184
 LocationRequest 6-194
 OriginationRequest 6-204
 RoutingRequest 6-253, 6-255, 6-256, 6-

1	257, 6-260	FeatureRequest 6-137
2	DEFAULT 6-312	InterSystemPage 6-179
3	FeatureRequest 6-137	InterSystemPage2 6-184
4	FeatureRequest RETURN RESULT 5-50	LocationRequest 6-194
5	Inactive 6-312, 6-339	OriginationRequest 6-204
6	FeatureRequest 6-137, 6-138	RoutingRequest 6-253
7	InterSystemPage 6-179	Unavailable 6-204, 6-311
8	InterSystemPage2 6-184	FeatureRequest 6-137, 6-138
9	LocationRequest 6-194	InterSystemPage 6-179
10	OriginationRequest 6-204	InterSystemPage2 6-184
11	RoutingRequest 6-251, 6-252, 6-253, 6-	LocationRequest 6-194
12	254, 6-260	OriginationRequest 6-204
13	InterSystemPage 6-175, 6-176, 6-179	RoutingRequest 6-253, 6-254, 6-260, 6-
14	InterSystemPage RETURN RESULT 5-73	261
15	InterSystemPage2 6-180, 6-184, 6-185	ACDGTS , 5-191
16	InterSystemPage2 RETURN RESULT 5-75	ACK
17	IntersystemTermination 5-206	ACSE
18	LocationRequest 6-189, 6-192, 6-194	ACT , , 4-15
19	LocationRequest RETURN RESULT 5-78	ACTCODE , 3-50, 3-52, 3-87, 3-155, 3-156,
20	No Page Response 6-311	5-129
21	FeatureRequest 6-137, 6-138	Action To Be Taken On Detection Of Dual Seizure
22	InterSystemPage 6-176, 6-177, 6-178, 6-	4-20
23	179	ActionCode 1-14, 5-124,
24	InterSystemPage2 6-183, 6-184	Bridge leg(s) to conference call
25	LocationRequest 6-194	MSC ActionCode Processing 6-24
26	OriginationRequest 6-204	Conference calling drop last party 6-338
27	RoutingRequest 6-253, 6-260	MSC ActionCode Processing 6-24
28	NoPageResponse	DEFAULT
29	page an MS 6-28	MSC ActionCode Processing 6-25
30	OriginationRequest 6-201, 6-202, 6-204	Disconnect all call legs 6-346, 6-347, 6-359,
31	OriginationRequest RETURN RESULT 5-82	6-360
32	page an MS 6-28	Disconnect call
33	RoutingRequest 6-251, 6-253, 6-254, 6-255,	MSC ActionCode Processing 6-24
34	6-260, 6-261	Disconnect call leg 6-346, 6-359, 6-360
35	RoutingRequest RETURN RESULT 5-101	MSC ActionCode Processing 6-24
36	Termination Denied 6-312	Drop leg on busy or routing failure
37	FeatureRequest 6-137	MSC ActionCode Processing 6-25
38	InterSystemPage 6-176, 6-179	FeatureRequest 6-128
39	InterSystemPage2 6-184	FeatureRequest RETURN RESULT 5-50
40	LocationRequest 6-194	MSC ActionCode Processing 6-24
41	OriginationRequest 6-204	OriginationRequest 6-201
42	RoutingRequest 6-250, 6-251, 6-253, 6-	OriginationRequest RETURN RESULT 5-82
43	260, 6-261	TransferToNumberRequest 6-297
44	Termination Denied. 6-366	TransferToNumberRequest RETURN RESULT
45	TransferToNumberRequest 6-297, 6-298, 6-	5-111
46	299	Active , 1-14, , 4-11, 4-12, 4-21, 4-22, 4-
47	TransferToNumberRequest RETURN RESULT	23
48	5-111	Address translation failure
49	Unassigned directory number 6-260, 6-312	SMS_CauseCode
50		
51		
52		
53		
54		
55		
56		
57		
58		
59		
60		

Address vacant	MSC special MS alerting 6-33	1
SMS_CauseCode	AlertTime 1-14	2
ADFT , 5-31, 6-58, 6-59, 6-61,	All	3
Adjunct MSC	SPINITriggers	4
Adjusted Signal Quality 1-21	All Origination	5
ADT , 5-29, 6-43, 6-44, 6-45, 6-48, 6-49, 6-	OriginationTriggers	6
52, 6-53, 6-74, 6-75,	SPINITriggers	7
Advanced Mobile Phone System 1-14	AllCircuitsBusy	8
AE	AnnouncementCode, Standard Announcement	9
AFREPORT , 3-19		10
AFRT , 5-32, 6-62, 6-63, 6-65, 6-67, 6-72, 6-	Alliance for Telecommunications Industry Solutions	11
75,	1-14	12
Ai reference point	Allow all	13
Alcatel SEL 5-300	SMS_OriginationRestrictions	14
Aldiscon 5-300	SMS_TerminationRestrictions	15
alert pip tone 5-131	Allow Direct.	16
MessageWaitingNotificationType	SMS_OriginationRestrictions	17
Alert without waiting to report	Allow message terminations charged to the	18
AlertCode, Alert Action	destination	19
AlertCode 1-14, 5-67, 5-68, 5-122, , 5-132,	SMS_TerminationRestrictions	20
5-133, 6-310, 6-329, 6-342, 6-356, 6-357	Allow specific	21
InformationDirective 6-168, 6-169	SMS_OriginationRestrictions	22
InformationDirective INVOKE 5-66	SMS_TerminationRestrictions	23
InformationForward 6-171	Allowed Call Types	24
InformationForward INVOKE 5-68	OriginationIndicator 5-222	25
InterSystemPage INVOKE 5-72	AllowedDigits DigitMask	26
InterSystemPage2 INVOKE 5-74	DigitCollectionControl 5-186	27
LocalTermination 5-208	ALRTCODE , 3-56, 3-58, 3-61, 3-66, 3-131,	28
MS termination alerting 6-30	3-160, 5-130	29
MSC special MS alerting 6-33	ALRTRES , 3-56, 3-58, 5-132	30
RoutingRequest 6-257	AlternateOperatorServices	31
RoutingRequest INVOKE 5-99	AnnouncementCode, Standard Announcement	32
UnsolicitedResponse RETURN RESULT 5-118		33
ALERTIME	American National Standards Institute 1-14	34
alerting 5-131	AMPS ,	35
alerting timer 6-400	AMPS channel acceptable	36
FacilitiesDirective 6-119, 6-123	CDMACallMode	37
InterSystemAnswer 6-173, 6-174	NAMPSCallMode	38
MS termination alerting 6-31	TDMACallMode	39
MSC route the call externally 6-37, 6-38	AMPS channel not acceptable	40
MSC special MS alerting 6-33	CDMACallMode	41
AlertResult 1-14, 5-124,	NAMPSCallMode	42
Failure	TDMACallMode	43
MSC special MS alerting 6-33	Analog	44
InformationDirective RETURN RESULT 5-67	Analog to Digital 1-14	45
InformationForward RETURN RESULT 5-68	Analog Transmission	46
NoPageResponse	CDMAStationClassMark 5-172	47
MSC special MS alerting 6-34	Anchor Market ID	48
Success	BillingID 5-150	49

1 Anchor MSC
 2 Anchor MSC Initiating an Authentication Directive
 3 Forward
 4 FacilitiesRelease 6-125
 5 InterSystemPage5- 6-182
 6 Anchor MSC Initiating SMS Delivery Point-To-
 7 Point , 6-417
 8 SMSDeliveryBackward 6-263
 9 Anchor MSC Receiving a FlashRequest INVOKE
 10
 11 Anchor MSC Receiving a HandoffToThird INVOKE
 12
 13 Anchor Switch Number
 14 BillingID 5-150
 15 ANNCODE , 5-133
 16 ANNLIST , 3-50, 3-52, 3-56, 3-58, 3-75, 3-81,
 17 3-87, 3-88, 3-127, 3-128, 3-155, 3-156, 5-141
 18 AnnouncementCode 1-14, 5-122, , 5-141, 6-
 19 308, 6-309, 6-311, 6-312, 6-313, 6-314, 6-315,
 20 6-316, 6-317, 6-318, 6-319, 6-320, 6-322, 6-
 21 323, 6-324, 6-326, 6-327, 6-328, 6-330, 6-331,
 22 6-335, 6-336, 6-337, 6-338, 6-339, 6-340, 6-
 23 341, 6-345, 6-348, 6-349, 6-350, 6-352, 6-353,
 24 6-354, 6-355, 6-356, 6-362, 6-363, 6-364, 6-
 25 365, 6-366, 6-367, 6-369, 6-374, 6-375, 6-376,
 26 6-377, 6-378, 6-379, 6-380, 6-381, 6-382, 6-
 27 383, 6-384, 6-385, 6-386, 6-387, 6-388, 6-389,
 28 6-390, 6-391, 6-392, 6-393, 6-394, 6-395, 6-
 29 396, 6-397, 6-398
 30 HLR analyze MS dialed number 6-19
 31 LocationRequest 6-191, 6-192
 32 MSC special MS alerting 6-34
 33 None 5-140
 34 play all announcements 6-19, 6-20
 35 TransferToNumberRequest 6-298, 6-299, 6-
 36 300
 37 AnnouncementList 1-14, 5-50, 5-82, 5-111, 5-124,
 38 , 5-316, 6-308, 6-309, 6-311, 6-312, 6-313,
 39 6-314, 6-315, 6-316, 6-317, 6-318, 6-319, 6-
 40 320, 6-322, 6-323, 6-324, 6-326, 6-327, 6-328,
 41 6-330, 6-331, 6-335, 6-336, 6-337, 6-338, 6-
 42 339, 6-340, 6-341, 6-343, 6-345, 6-348, 6-349,
 43 6-350, 6-352, 6-353, 6-354, 6-355, 6-356, 6-
 44 358, 6-362, 6-363, 6-364, 6-365, 6-366, 6-367,
 45 6-369, 6-374, 6-375, 6-376, 6-377, 6-378, 6-
 46 379, 6-380, 6-381, 6-382, 6-383, 6-384, 6-385,
 47 6-386, 6-387, 6-388, 6-389, 6-390, 6-391, 6-
 48 392, 6-393, 6-394, 6-395, 6-396, 6-397, 6-398
 49 FeatureRequest 6-127
 50 FeatureRequest RETURN RESULT 5-50
 51 HLR analyze MS dialed number 6-19
 52 idle MS origination 6-13
 53 incoming call attempt 6-25
 54 InformationDirective 6-168, 6-169
 55 InformationDirective INVOKE 5-66
 56 InformationForward 6-171
 57 InformationForward INVOKE 5-68
 58 LocationRequest 6-189, 6-190, 6-191, 6-192
 59 LocationRequest RETURN RESULT 5-78
 60 MSC analyze MS dialed number 6-18
 MSC special MS alerting 6-33
 OriginationRequest 6-201, 6-202
 OriginationRequest RETURN RESULT 5-82
 play all announcements 6-19
 RemoteUserInteractionDirective 6-246, 6-247
 RemoteUserInteractionDirective INVOKE 5-97
 TransferToNumberRequest 6-296, 6-297, 6-
 298, 6-299, 6-300
 TransferToNumberRequest RETURN RESULT
 5-111
 Announcements
 TransactionCapability
 ANSI
 ANSI SS7 Point Code (PC) and Subsystem
 Number (SSN)
 DigitsType, Numbering Plan
 ANSI T1 , 1-25
 ANSI T1.607 5-330
 AnswerTone
 AnnouncementCode, Tone
 Anticipatory
 HandoffReason
 APDU
 Application Entity 1-14
 Application Protocol Data Unit 1-14
 Application Service Element 1-14
 Application Service Part 1-14
 Apply a reminder alert once
 AlertCode, Alert Action
 Apply Access Denial Treatment , 6-41, 6-422,
 6-424, 6-426, 6-428, 6-430, 6-432, 6-434, 6-436,
 6-438, 6-440, 6-442, 6-444, 6-446, 6-448, 6-450,
 6-452, 6-454, 6-456, 6-458, 6-460, 6-462
 authorize MS termination attempt 6-29
 idle MS origination 6-13
 incoming call attempt 6-25
 MS termination alerting 6-30
 MSC analyze MS dialed number 6-18

OriginationRequest 6-201	SystemCapabilities	1
Apply Busy Treatment , 6-422, 6-424, 6-428,	Authentication Request Timer 1-14,	2
6-430, 6-432, 6-434, 6-436, 6-438, 6-440, 6-442,	Authentication required	3
6-444, 6-446, 6-448, 6-450, 6-452, 6-454, 6-456,	AuthenticationCapability	4
6-458, 6-460, 6-462	Authentication Response 5-238	5
Area Code 1-19	Authentication Response Verification	6
ART , 5-34, 6-77, 6-78, 6-81, 6-83, 6-85, 6-	AuthenticationRequest 6-79, 6-88	7
86, 6-181,	authentication response verification procedures	8
ASE	-	9
ASN.1	Authentication Status Report Response Timer 1-	10
ASP	14,	11
ASREPORT , 3-36	Authentication Status Report Timer 1-14,	12
ASRRT , 6-93, 6-96, 6-100, 6-102,	AuthenticationCapability 3-93, 3-100	13
ASRT , 5-36, 6-92, 6-93, 6-94, 6-96, 6-98, 6-	AuthenticationAlgorithmVersion 1-14, 3-8, 3-24,	14
99,	3-39, 5-122,	15
Assigned to timeslot 1, full rate	AuthenticationDirective INVOKE 5-29	16
Assigned to timeslot 1, half rate	AuthenticationFailureReport RETURN RESULT	17
Assigned to timeslot 2, full rate	5-33	18
Assigned to timeslot 2, half rate	AuthenticationRequest RETURN RESULT 5-	19
Assigned to timeslot 3, full rate	35	20
Assigned to timeslot 3, half rate	AuthenticationStatusReport RETURN RESULT	21
Assigned to timeslot 4, half rate	5-37	22
Assigned to timeslot 5, half rate	AuthenticationAlgorithmVersion (AAV)	23
Assigned to timeslot 6, half rate	AuthenticationDirective 6-42, 6-43, 6-47, 6-	24
Association Control Service Element 1-14	48, 6-49	25
assumptions	AuthenticationFailureReport 6-63, 6-64, 6-70,	26
Astronet 5-300	6-73, 6-74, 6-75	27
ATIS	AuthenticationRequest 6-81, 6-82, 6-90	28
AudibleAlerting	AuthenticationStatusReport 6-94, 6-95, 6-96,	29
AnnouncementCode, Tone	6-101	30
AUTH	AuthenticationCapability 1-14, 3-121, 5-122,	31
SystemCapabilities	6-76	32
AUTH=0 in the OMT 5-298	AuthenticationRequest 6-75, 6-78	33
AUTH=1 in the OMT 5-298	loading of profile parameters 6-10	34
AUTHBS , 3-43, 3-44, 5-146	Profile 5-234	35
AUTHCAP , 5-143	QualificationDirective INVOKE 5-234	36
AUTHDATA , 3-27, 5-144	QualificationRequest RETURN RESULT 5-234	37
AUTHDEN , 3-95, 3-96, 3-103, 3-125, 5-147	registration call tasks 6-9	38
AUTHDIR , 3-6	RegistrationNotification RETURN RESULT 5-	39
AUTHDIRFWD , 3-17	234	40
Authentication Center 1-14, 1-24	AuthenticationData 1-14, 5-126,	41
Authentication Directive Forward Timer 1-14,	AuthenticationRequest 6-77	42
	AuthenticationRequest INVOKE 5-34	43
Authentication Directive Timer 1-14,	AuthenticationDirective 1-14, 5-6, 5-25, 5-27,	44
Authentication Failed	, 5-30, 6-400	45
InterSystemPage2 6-181	operation definition 3-6-3-16, 5-29-5-30	46
Authentication Failure Report Timer 1-14,	operation usage	47
Authentication Indicator 1-14	general 3-187, 3-190, 3-194, 3-197, 3-	48
Authentication Parameters Requested	198	49

1	AuthenticationDirective procedures -	5-37
2	AuthenticationDirectiveForward 1-14, 5-6, 5-25,	AuthenticationStatusReport 1-14, 5-6, 5-25, 5-27,
3	5-27, , 6-400	, 5-37, 6-400, 6-407, 6-409, 6-410
4	operation definition 3-17-3-18, 5-31	AuthenticationDirective 6-46, 6-50, 6-52
5	AuthenticationDirectiveForward procedures -	operation definition 3-36-3-40, 5-36-5-37
6		operation usage
7		general 3-182, 3-184, 3-188, 3-190, 3-
8	AuthenticationFailureReport 1-14, 5-6, 5-25, 5-27,	195, 3-199
9	, 5-33, 6-400	AuthenticationStatusReport procedures -
10	operation definition 3-19-3-20, 5-32	
11	AuthenticationFailureReport procedures -	
12	AuthenticationRequest 1-14, 5-6, 5-25, 5-27,	AuthorizationDenied 1-14, 5-84, 5-87, 5-96, 5-119,
13	5-35, 6-400	, 6-464, 6-465, 6-467, 6-468
14	operation definition 3-21-3-35, 5-33, 5-34-5-	Delinquent Account 6-215
15	35	FeatureRequest 6-137, 6-138
16	operation usage	LocationRequest 6-195
17	general 3-182, 3-184, 3-192	MSInactive 6-199
18	AuthenticationRequest procedures -	OriginationRequest 6-204
19	AuthenticationResponse 1-14, 5-120,	QualificationRequest 6-215, 6-217
20	AuthenticationRequest INVOKE 5-34	RegistrationNotification 6-240, 6-244
21	InterSystemPage2 RETURN RESULT 5-75	TransferToNumberRequest 6-302
22	AuthenticationResponse (AUTHR)	Duplicate Unit
23	AuthenticationRequest 6-76, 6-77, 6-79, 6-84,	FeatureRequest 6-137, 6-138
24	6-86, 6-88, 6-89, 6-92	LocationRequest 6-195
25	InterSystemPage5- 6-181, 6-183	MSInactive 6-199
26	AuthenticationResponseBaseStation 1-14, 5-120,	OriginationRequest 6-204
27		QualificationRequest 6-215, 6-217
28	BaseStationChallenge RETURN RESULT 5-38	RegistrationNotification 6-240, 6-244
29	AuthenticationResponseBaseStation (AUTHBS)	TransferToNumberRequest 6-302
30	BaseStationChallenge 6-104, 6-108	Invalid Serial Number
31	AuthenticationResponseUnique (AUTHU) 6-409	QualificationRequest 6-215, 6-217
32	AuthenticationDirective 6-43, 6-47, 6-48, 6-	RegistrationNotification 6-240, 6-244
33	50, 6-52	Missing authentication parameters
34	AuthenticationDirectiveForward 6-58, 6-59	QualificationRequest 6-215, 6-217
35	AuthenticationFailureReport 6-64, 6-70, 6-73,	RegistrationNotification 6-240, 6-244
36	6-74	MSC analyze MS dialed number 6-18
37	AuthenticationRequest 6-80, 6-82, 6-88, 6-90	Multiple access
38	AuthenticationStatusReport 6-94, 6-95, 6-101	QualificationRequest 6-215, 6-217
39	InterSystemPage2 6-182	RegistrationNotification 6-235, 6-238, 6-
40	MSC receiving authentication parameters 6-54,	240, 6-241, 6-242, 6-244
41	6-56	Not Authorized for the MSC
42	AuthenticationResponseUniqueChallenge 1-15, 5-	QualificationRequest 6-215, 6-217
43	120,	RegistrationNotification 6-240, 6-244
44	AuthenticationDirective INVOKE 5-29	QualificationDirective 6-205, 6-206, 6-207, 6-
45	AuthenticationDirectiveForward INVOKE 5-31	208, 6-210
46	AuthenticationFailureReport RETURN RESULT	QualificationDirective INVOKE 5-84
47	5-33	QualificationRequest 6-211, 6-212, 6-213, 6-
48	AuthenticationRequest RETURN RESULT 5-	215, 6-216, 6-217
49	35	QualificationRequest RETURN RESULT 5-87
50	AuthenticationStatusReport RETURN RESULT	RegistrationNotification 6-234, 6-238, 6-242,
51		
52		
53		
54		
55		
56		
57		
58		
59		
60		

6-244	GeographicAuthorization	1
RegistrationNotification RETURN RESULT 5-96	Authorized for this MarketID and Switch Number only	2
Stolen Unit	GeographicAuthorization	3
FeatureRequest 6-137, 6-138	Authorized for this MarketID only	4
LocationRequest 6-195	GeographicAuthorization	5
MSInactive 6-199	AuthorizedSubscriberOrigination	6
OriginationRequest 6-204	MSC analyze MS dialed number 6-18	7
QualificationRequest 6-215, 6-217	AUTHPER , 3-90, 3-98, 3-120, 5-148	8
RegistrationNotification 6-240, 6-244	AUTHR , 3-23, 3-67, 5-145	9
TransferToNumberRequest 6-302	AUTHR mismatch	10
TerminalType mismatch	DenyAccess, Reason	11
QualificationRequest 6-215, 6-217	ReportType	12
RegistrationNotification 6-240, 6-244	AUTHREQ , 3-21	13
Unassigned directory number	AUTHU , 3-8, 3-10, 3-13, 3-15, 3-18, 3-24, 3-32, 3-33, 3-35, 3-39, 3-40, 5-146	14
MSInactive 6-199	automatic callback 5-131	15
QualificationRequest 6-215, 6-217	Automatic Number Identification (ANI)	16
RegistrationNotification 6-240, 6-244	MSC route the call externally 6-35	17
Unspecified	automatic recall 5-131	18
FeatureRequest 6-138	Automatic Repeat Attempt 4-9	19
LocationRequest 6-195	Automatic Roaming	20
MSInactive 6-199	Autonomous or Power-On Registration	21
OriginationRequest 6-204	Autonomous registration	22
QualificationRequest 6-215, 6-217	SystemAccessType	23
RegistrationNotification 6-235, 6-240, 6-244	AvailabilityType 1-15, 5-122,	24
TransferToNumberRequest 6-302	RegistrationNotification 6-236, 6-237, 6-242, 6-243	25
AuthorizationPeriod 1-14, 5-119,	RegistrationNotification INVOKE 5-94	26
QualificationDirective 6-205, 6-207, 6-208, 6-210	Unspecified mobile inactivity type	27
QualificationDirective INVOKE 5-84	RegistrationNotification 6-234	28
QualificationRequest 6-213, 6-215, 6-216, 6-217	Available	29
QualificationRequest RETURN RESULT 5-87	AVTYP , 3-119, 5-149	30
RegistrationNotification 6-237, 6-242	Await Answer	31
RegistrationNotification RETURN RESULT 5-96	MS termination alerting 6-29, 6-32	32
Authorize MS Termination Attempt		33
LocationRequest 6-190		34
MSC Routing Points of Return 6-21		35
wait for TLDN call 6-26		36
Authorized and activated		37
CallingFeaturesIndicator		38
Authorized but de-activated		39
CallingFeaturesIndicator		40
Authorized for all MarketIDs served by the VLR		41
GeographicAuthorization		42
Authorized for this LocationAreaID within a MarketID only		43
	B	44
		45
	B reference point	46
	Band Class	47
	CDMAChannelData 5-164	48
	Bandwidth	49
	StationClassMark	50
	BargeInTone	51
	AnnouncementCode, Tone	52
	Base Station 1-15, 1-24,	53
	Base Station Challenge 6-405	54
	Base Station Challenge Timer 1-15,	55
		56
		57
		58
		59
		60

1 BaseStationChallenge 1-15, 5-6, 5-25, 5-27, , MSC route the call externally 6-35, 6-36
 2 6-400 RedirectionDirective 6-221, 6-222
 3 operation definition 3-41-3-44, 5-38 RedirectionRequest 6-224, 6-225
 4 operation usage RoutingRequest 6-250, 6-259
 5 general 3-187, 3-194 TransferToNumberRequest 6-296
 6 BaseStationChallenge procedures - UnsolicitedResponse 6-304
 7 basic call processing procedures 6-9-6-42 BillingID (Anchor)
 8 Basic Encoding Rules 1-15, 5-329 RoutingRequest RETURN RESULT 5-101
 9 BCD UnsolicitedResponse INVOKE 5-117
 10 DigitsType, Encoding BillingID (Originating)
 11 BDT , 5-40, 6-110, FeatureRequest INVOKE 5-48
 12 BearerData 6-411, 6-412 InterSystemPage INVOKE 5-72
 13 Bellcore 5-300 InterSystemPage2 INVOKE 5-74
 14 BER LocationRequest INVOKE 5-77
 15 BID OriginationRequest INVOKE 5-81
 16 BILLDGTS , 5-193 RedirectionDirective INVOKE 5-89
 17 BILLID , 2-14, 2-15, 3-50, 3-52, 3-62, 3-71, RedirectionRequest INVOKE 5-91
 18 3-74, 3-87, 3-107, 3-110, 3-132, 3-154, 5-150 RoutingRequest INVOKE 5-99
 19 Billing Number TransferToNumberRequest INVOKE 5-110
 20 DigitsType, Type of Digits UnsolicitedResponse RETURN RESULT 5-118
 21 Billing System Identifier 1-15 BillingID (Terminating)
 22 BillingID 1-15, 2-5, 2-7, 2-12, 2-17, 2-18, 2-23, 2- InterSystemPage RETURN RESULT 5-73
 23 31, 2-44, 2-46, 2-50, 2-52, 2-54, 2-56, 2-58, 2- IntersystemTermination 5-206
 24 60, 2-67, 3-61, 3-66, 3-131, 3-159, 3-160, 5- Binary Coded Decimal 1-15
 25 110, 5-119, , 6-313, 6-341, 6-343, 6-346, BLKT , 4-2, 4-4, , 5-39
 26 6-356, 6-358, 6-359, 6-360 Block all
 27 (Originating) SMS_OriginationRestrictions
 28 LocationRequest 6-188 SMS_TerminationRestrictions
 29 OriginationRequest 6-201 Block Direct
 30 (Serving) SMS_OriginationRestrictions
 31 InterSystemPage 6-178 Block message terminations charged to the
 32 FacilitiesDirective 6-117, 6-120, 6-122 destination
 33 FacilitiesDirective (path minimization) 6-164 SMS_TerminationRestrictions
 34 FacilitiesDirective INVOKE 5-42 Blocked
 35 FacilitiesDirective2 INVOKE 5-44 TrunkStatus
 36 FacilitiesRelease 6-124, 6-125, 6-126 BLOCKING , 4-2, 4-9, 4-10, 4-11, 4-12, 4-13,
 37 FacilitiesRelease INVOKE 5-47 4-15, 4-18, 4-22, 4-23, 4-24, 4-25, 4-26, 5-6,
 38 FacilitiesRelease RETURN RESULT 5-47 5-24, 5-27,
 39 FeatureRequest 6-127 operation definition 4-4, 5-39
 40 HandoffBack 6-144, 6-147, 6-148 Blocking and Unblocking of Circuits 4-9
 41 HandoffBack INVOKE 5-53 Blocking States 4-10
 42 HandoffBack2 INVOKE 5-55 Blocking Timer 1-15,
 43 HandoffToThird 6-155, 6-160, 6-163 BORDACC , 3-119, 5-151
 44 HandoffToThird INVOKE 5-61 Border Cell Access
 45 HandoffToThird2 INVOKE 5-63 BorderCellAccess
 46 InterSystemPage 6-175 Border Cell problem 5-241
 47 InterSystemSetup 6-185, 6-187 Border MSC
 48 InterSystemSetup INVOKE 5-76 ExtendedMSCID, type
 49 MSC record the DMH parameters 6-34 ExtendedSystemMyTypeCode
 50
 51
 52
 53
 54
 55
 56
 57
 58
 59
 60

	StationClassMark	
PC_SSN, Type		1
BorderCellAccess 1-15, 5-121,		2
Border cell access		3
RegistrationNotification 6-233	C	4
RegistrationNotification 6-237		5
RegistrationNotification INVOKE 5-94	C reference point	6
Break 5-188	Call accepted 6-191, 6-192	7
BreakIn	RedirectionReason	8
DigitCollectionControl	Call Data Request Timer 1-15	9
Bridge call leg(s) to conference call	Call Delivery , 1-15, 5-71, 5-94, 5-138, 5-148,	10
ActionCode	5-149, 5-194, 5-195	11
BRK	FeatureActivity 5-154	12
DigitCollectionControl 5-186	MS termination alerting 6-32	13
BS , 1-24,	Call Delivery (CD) procedures -	14
BSCHALL , 3-41	Call Delivery Method	15
BSCT , 5-38, 6-104, 6-105, 6-107,	Call Disconnect	16
Buffer	Call Forwarding 5-138	17
DigitCollectionControl	Call Forwarding Unconditional	18
Bulk Deregistration Timer 1-15,	wait for TLDN call 6-26	19
BULKDEREG , 3-45	Call Forwarding-Default 5-195	20
BulkDeregistration 1-15, 5-6, 5-25, 5-27, , 6-	Call Forwarding≡Busy 5-194	21
400	Call Forwarding≡Busy FeatureActivity 5-154	22
operation definition 3-45, 5-40	Call Forwarding≡No Answer 5-194	23
BulkDeregistration procedures -	Call Forwarding≡No Answer FeatureActivity 5-154	24
Burst Code	Call Forwarding≡Other 5-194	25
TDMABurstIndicator 5-303	Call Forwarding≡Unconditional 5-194	26
Busy	Call Forwarding≡Unconditional FeatureActivity 5-	27
AccessDeniedReason	154	28
AlertResult	Call ForwardingΔBusy 1-15	29
CancellationDenied	MS termination alerting 6-32	30
DMH_RedirectionIndicator	Call ForwardingΔBusy (CFB) procedures -	31
RedirectionReason		32
TerminationTriggers	Call ForwardingΔDefault 1-16	33
Busy Call	Call ForwardingΔDefault (CFD) procedures -	34
TerminationTriggers		35
Busy Detection	Call ForwardingΔNo Answer 1-16	36
TransactionCapability	MS termination alerting 6-29	37
Busy Leg	Call ForwardingΔNo Answer (CFNA) procedures	38
TerminationTriggers	-	39
Busy MS Detected 6-32	Call ForwardingΔUnconditional 1-16	40
Busy MS Detected GSL	Call ForwardingΔUnconditional (CFU) procedures	41
Busy Re-Routing GSL	-	42
Busy Trigger	Call Mode	43
TerminationTriggers	NAMPSCallMode 5-217	44
BusyTone	TDMACallMode 5-304	45
AnnouncementCode, Tone	Call origination	46
BusyTrigger	SystemAccessType	47
originating call sent 6-22, 6-23	Call Origination GSL	48
BW	Call refused	49

1	RedirectionReason	93
2	Call Release	CallHistoryCount (COUNT)
3	call release procedures	AuthenticationDirective 6-43, 6-47, 6-48
4	RedirectionDirective 6-221	AuthenticationFailureReport 6-64, 6-66, 6-68,
5	RedirectionRequest 6-223	6-70, 6-72, 6-73
6	call restriction 5-222	AuthenticationRequest 6-76, 6-79, 6-82, 6-84,
7	Call Termination	6-86, 6-88, 6-89, 6-90, 6-92
8	call termination service 5-235	AuthenticationStatusReport 6-93, 6-95, 6-97,
9	Call Transfer 1-16	6-100, 6-101, 6-103
10	Explicit 5-195	CountRequest 6-111, 6-112, 6-114
11	FeatureActivity 5-154	InterSystemPage2 6-181, 6-183
12	MS termination alerting 6-32	MSInactive 6-197, 6-198, 6-199, 6-200
13	MSC analyze MS dialed number 6-15	RegistrationCancellation 6-226, 6-228
14	Call Transfer (CT) 5-221	CallHistoryCountExpected 1-16, 5-122,
15	Call Transfer (CT) procedures	AuthenticationFailureReport INVOKE 5-32
16	call transfer, explicit	AuthenticationRequest 6-79
17	DMH_RedirectionIndicator 5-195	Calling Number Identification 1-16
18	Call Waiting 1-16, 5-73, 5-101, 5-177	Calling Number Identification Presentation 1-16,
19	FeatureActivity 5-154	5-154
20	MS termination alerting 6-32	FeatureActivity 5-154
21	MSC analyze MS dialed number 6-15	Calling Number Identification Presentation (CNIP)
22	Priority 5-154,	procedures -
23	RoutingRequest 6-255	Calling Number Identification Restriction 1-16, 5-
24	Call Waiting (CW) procedures -	154
25	Call Waiting for Future Incoming Call	FeatureActivity 5-154
26	OneTimeFeatureIndicator 5-220	OneTimeFeatureIndicator 5-221
27	Call Waiting for Incoming Call	Override FeatureActivity 5-154
28	OneTimeFeatureIndicator 5-220	Calling Number Identification Restriction (CNIR)
29	Called Party Number	procedures -
30	DigitsType, Type of Digits	Calling Party Number
31	Caller Interaction	DigitsType, Type of Digits
32	DigitsType, Type of Digits	CallingFeaturesIndicator 1-16, 3-92, 3-100, 3-120,
33	CallHistoryCount 1-16, 3-24, 3-33, 3-39, 5-41, 5-	5-120, , 5-179, 6-329, 6-389, 6-396
34	120, , 5-319	Call Waiting
35	AuthenticationDirective INVOKE 5-29	initialize OTFI 6-23
36	AuthenticationDirective RETURN RESULT 5-	MS termination alerting 6-31
37	30	CFNA-FA
38	AuthenticationFailureReport INVOKE 5-32	MS termination alerting 6-30
39	AuthenticationFailureReport RETURN RESULT	CNIR
40	5-33	initialize OTFI 6-24
41	AuthenticationRequest INVOKE 5-34	loading of profile parameters 6-10
42	AuthenticationRequest RETURN RESULT 5-	MS termination alerting 6-29
43	35	Priority Call Waiting
44	AuthenticationStatusReport RETURN RESULT	initialize OTFI 6-23
45	5-37	MS termination alerting 6-31
46	CountRequest RETURN RESULT 5-41	Profile 5-234
47	InterSystemPage2 RETURN RESULT 5-75	QualificationDirective 6-207, 6-210
48	MSInactive INVOKE 5-80	QualificationDirective INVOKE 5-234
49	RegistrationCancellation RETURN RESULT 5-	QualificationRequest 6-215, 6-217
50		
51		
52		
53		
54		
55		
56		
57		
58		
59		
60		

QualificationRequest RETURN RESULT 5-234	UnsolicitedResponse RETURN RESULT 5-118		
RegistrationNotification RETURN RESULT 5-234	CallingPartySubaddress 1-16, 3-58, 3-61, 3-66, 3-131, 3-155, 3-160, 5-122, , 6-334, 6-335		1 2 3
CallingPartyNumberDigits1 1-16, 5-122, , 6-332, 6-333, 6-334, 6-335, 6-336	FeatureRequest INVOKE 5-48		4
FeatureRequest INVOKE 5-48	FeatureRequest RETURN RESULT 5-50		5
LocationRequest 6-188, 6-191	InformationDirective INVOKE 5-66		6
LocationRequest INVOKE 5-77	InformationForward 6-171		7
OriginationRequest INVOKE 5-81	InformationForward INVOKE 5-68		8
Presentation Allowed 6-336	InterSystemPage 6-175		9
Presentation Restricted 6-336	InterSystemPage INVOKE 5-72		10
TransferToNumberRequest 6-296	InterSystemPage2 INVOKE 5-74		11
CallingPartyNumberDigits2 1-16, 5-122, , 6-332, 6-333, 6-335	LocationRequest 6-188		12
FeatureRequest INVOKE 5-48	LocationRequest INVOKE 5-77		13
LocationRequest 6-188	OriginationRequest INVOKE 5-81		14
LocationRequest INVOKE 5-77	OriginationRequest RETURN RESULT 5-82		15
OriginationRequest INVOKE 5-81	RoutingRequest 6-259		16
CallingPartyNumberString1 1-16, 3-58, 3-61, 3-66, 3-131, 3-155, 3-160, 5-122, , 6-332, 6-334	RoutingRequest INVOKE 5-99		17
FeatureRequest RETURN RESULT 5-50	TransferToNumberRequest 6-296		18
InformationDirective INVOKE 5-66	TransferToNumberRequest RETURN RESULT 5-111		19
InformationForward 6-171	UnsolicitedResponse RETURN RESULT 5-118		20
InformationForward INVOKE 5-68	CallMode 5-304		21
InterSystemPage 6-175	CallOverClearBackward 2-54		22
InterSystemPage INVOKE 5-72	ReleaseReason		23
InterSystemPage2 INVOKE 5-74	CallOverClearForward 2-56		24
LocationRequest RETURN RESULT 5-78	ReleaseReason		25
OriginationRequest RETURN RESULT 5-82	CallWaitingTone		26
RoutingRequest 6-259	AnnouncementCode, Tone		27
RoutingRequest INVOKE 5-99	MSC special MS alerting 6-34		28
TransferToNumberRequest RETURN RESULT 5-111	CancellationDenied 1-15, 5-121, , 6-464, 6-465, 6-467, 6-468		29
UnsolicitedResponse RETURN RESULT 5-118	Busy		30
CallingPartyNumberString2 1-16, 3-58, 3-61, 3-66, 3-131, 3-155, 3-160, 5-122, , 6-332, 6-334	RegistrationCancellation 6-230		31
FeatureRequest RETURN RESULT 5-50	Multiple Access		32
InformationDirective INVOKE 5-66	RegistrationCancellation 6-227		33
InformationForward 6-171	RegistrationCancellation 6-226, 6-227, 6-228, 6-230		34
InformationForward INVOKE 5-68	RegistrationCancellation RETURN RESULT 5-93		35
InterSystemPage 6-175	RegistrationNotification 6-242		36
InterSystemPage INVOKE 5-72	CancellationType 1-15, 5-122,		37
InterSystemPage2 INVOKE 5-74	Discontinue		38
LocationRequest RETURN RESULT 5-78	RegistrationCancellation 6-230		39
OriginationRequest RETURN RESULT 5-82	RegistrationCancellation 6-226, 6-227, 6-229, 6-230		40
RoutingRequest 6-259	RegistrationCancellation INVOKE 5-92		41
RoutingRequest INVOKE 5-99	ReportInCall		42
TransferToNumberRequest RETURN RESULT 5-111	RegistrationCancellation 6-230		43
	CANDEN , 3-117, 5-160		44

1	Candidate MSC	RegistrationNotification 3-224, 3-227
2	CandidateCells 2-26	RoutingRequest 3-216, 3-219, 3-220, 3-
3	CANTYP , 3-113, 5-161	224, 3-227, 3-274, 3-335
4	CARDGTS , 3-52, 5-162	UnsolicitedResponse 3-227
5	Carrier	RoutingRequest 3-239, 3-276
6	DigitsType, Type of Digits	CD-FA
7	carrier specific teleservices	CallingFeaturesIndicator
8	SMS_TeleserviceIdentifier 5-284	CD Failure
9	CarrierDigits 1-15, 3-87, 5-96, 5-122, , 5-	DMH_RedirectionIndicator
10	236	CD Local
11	FeatureRequest RETURN RESULT 5-50	DMH_RedirectionIndicator
12	IntersystemTermination 5-206	CD Private
13	loading of profile parameters 6-10	DMH_RedirectionIndicator
14	LocalTermination 5-208	CD PSTN
15	MSC route the call externally 6-36, 6-37	DMH_RedirectionIndicator
16	OriginationRequest RETURN RESULT 5-82	CD Unspecified
17	Profile 5-234	DMH_RedirectionIndicator
18	QualificationDirective INVOKE 5-234	CDEN , 5-177
19	QualificationRequest RETURN RESULT 5-234	CDMA ,
20	RegistrationNotification RETURN RESULT 5-	CDMA channel acceptable
21	234	CDMACallMode
22	CauseCode 6-412	CDMA channel not acceptable
23	CAVE	CDMACallMode
24	CAVE algorithm 5-142	CDMA Channel Number
25	CAVE Algorithm Capable	CDMAChannelData 5-164
26	SystemCapabilities	CDMA only
27	CBIS 5-300	CDMAStationClassMark
28	CC , , (see Conference Calling)	CDMACallMode 1-15, 2-10, 2-21, 2-28, 2-35, 5-
29	commanded disconnect 6-39	121,
30	FeatureRequest 3-278, 3-282, 3-284	FacilitiesDirective 6-117
31	originating call sent 6-22	FacilitiesDirective2 INVOKE 5-44
32	other party disconnect 6-39	HandoffBack 6-144
33	RoutingRequest 6-255	HandoffBack2 INVOKE 5-55
34	CCDATA , 5-180	HandoffMeasurementRequest2 INVOKE 5-59
35	CCI , 5-178	HandoffToThird 6-156
36	CCITT	HandoffToThird2 INVOKE 5-63
37	CCITT 1984	CDMACHAN , 5-166
38	CCITT 1988	CDMAChannelData 1-15, 2-10, 2-12, 2-21, 2-23,
39	CCS7	2-28, 2-35, 2-37, 5-121, , 5-176
40	CD , , (see Call Delivery), 6-320, 6-324	FacilitiesDirective 6-116, 6-117, 6-118, 6-120,
41	LocationRequest 3-239, 3-276	6-121
42	operations	FacilitiesDirective (path minimization) 6-164,
43	FeatureRequest 3-215	6-165
44	InterSystemPage 3-224	HandoffBack 6-143, 6-144, 6-146
45	LocationRequest 3-216, 3-218, 3-219, 3-	HandoffMeasurementRequest2 6-151, 6-152,
46	220, 3-221, 3-224, 3-227, 3-274	6-154
47	QualificationDirective 3-215	HandoffToThird 6-155, 6-156, 6-157, 6-158,
48	QualificationRequest 3-217	6-161
49	RegistrationCancellation 3-224, 3-227	HandoffToThird2 6-160, 6-163
50		
51		
52		
53		
54		
55		
56		
57		
58		
59		
60		

CDMAChannelData (Serving)	CDMAPrivateLongCodeMask 1-15, 2-11, 2-21, 2-35, 5-121,	1
FacilitiesDirective2 INVOKE 5-44	AuthenticationRequest RETURN RESULT 5-35	2
HandoffBack2 INVOKE 5-55	FacilitiesDirective2 INVOKE 5-44	3
HandoffMeasurementRequest2 INVOKE 5-59	HandoffBack2 INVOKE 5-55	4
HandoffToThird2 INVOKE 5-63	HandoffToThird2 INVOKE 5-63	5
CDMAChannelData (Target)	InterSystemSetup INVOKE 5-76	6
FacilitiesDirective2 RETURN RESULT 5-46	CDMAPrivateLongCodeMask (CDMAPLCM) 5-45,	7
HandoffBack2 RETURN RESULT 5-57	5-56, 5-64	8
HandoffToThird2 RETURN RESULT 5-65	AuthenticationRequest 6-80, 6-83, 6-85, 6-89	9
CDMACHINFO , 5-166	FacilitiesDirective 6-116, 6-121	10
CDMACHLIST , 5-167	FacilitiesDirective (path minimization) 6-164	11
CDMACodeChannel 1-15, 5-121,	HandoffBack 6-143, 6-146	12
CDMACodeChannelInformation 5-166	HandoffToThird 6-155, 6-158, 6-161	13
FacilitiesDirective 6-121	InterSystemSetup 6-185	14
HandoffBack 6-146	CDMAQUAL , 5-171	15
HandoffToThird 6-158, 6-161	,CDMASCI , 5-171	16
CDMACodeChannel-List 2-12, 2-23, 2-37	CDMASCM , 5-172	17
CDMACodeChannelInformation 1-15, 5-124,	CDMASearchWindow 1-15, 2-12, 2-23, 2-37, 5-121,	18
5-167	FacilitiesDirective 6-121	19
CDMACodeChannelList 5-167	FacilitiesDirective2 RETURN RESULT 5-46	20
FacilitiesDirective 6-121	HandoffBack 6-146	21
HandoffBack 6-146	HandoffBack2 RETURN RESULT 5-57	22
HandoffToThird 6-158, 6-161	HandoffToThird 6-158, 6-161	23
CDMACodeChannelList 1-15, 5-124,	HandoffToThird2 RETURN RESULT 5-65	24
FacilitiesDirective 6-121	CDMAServingOneWayDelay 1-15, 2-11, 2-21, 2-28,	25
FacilitiesDirective2 RETURN RESULT 5-46	2-35, 5-45, 5-56, 5-64, 5-121,	26
HandoffBack 6-146	FacilitiesDirective 6-117	27
HandoffBack2 RETURN RESULT 5-57	FacilitiesDirective2 INVOKE 5-44	28
HandoffToThird 6-158, 6-161	HandoffBack 6-144	29
HandoffToThird2 RETURN RESULT 5-65	HandoffBack2 INVOKE 5-55	30
CDMADATA , 5-164	HandoffMeasurementRequest2 INVOKE 5-59	31
CDMAMAHO , 5-173	HandoffToThird 6-156	32
CDMAMAHOLIST , 5-173	HandoffToThird2 INVOKE 5-63	33
CDMAMEAS , 5-174	CDMASignalQuality 1-15, 5-121,	34
CDMAMEASLIST , 5-174	CDMATargetMeasurementInformation 5-174	35
CDMAMobileProtocolRevision 1-15, 2-11, 2-21, 2-35, 5-121,	HandoffMeasurementRequest2 6-153	36
FacilitiesDirective 6-117	CDMASlotCycleIndex 1-15, 3-61, 3-66, 5-126,	37
FacilitiesDirective2 INVOKE 5-44	InterSystemPage 6-175	38
HandoffBack 6-144	InterSystemPage INVOKE 5-72	39
HandoffBack2 INVOKE 5-55	InterSystemPage2 INVOKE 5-74	40
HandoffToThird 6-156	CDMASOWD , 5-170	41
HandoffToThird2 INVOKE 5-63	CDMAStationClassMark 1-15, 2-10, 2-21, 2-28, 2-35, 3-61, 3-66, 5-121,	42
CDMAMODE , 5-163	FacilitiesDirective 6-117	43
CDMAMPR , 5-167	FacilitiesDirective2 INVOKE 5-44	44
CDMAPILOT , 5-168	CDMAPLCM , 3-27, 3-28, 3-33, 3-71, 5-169	45
CDMAPilotStrength 1-15, 5-121,		46
CDMATargetMAHOInformation 5-173		47
CDMAPLCM , 3-27, 3-28, 3-33, 3-71, 5-169		48

1	HandoffBack 6-144	CellID
2	HandoffBack2 INVOKE 5-55	ServingCellID 5-252
3	HandoffMeasurementRequest2 6-154	SystemAccessData 5-295
4	HandoffMeasurementRequest2 INVOKE 5-59	TargetCellID 5-301
5	HandoffToThird 6-156	Cellular Authentication and Voice Encryption 1-15
6	HandoffToThird2 INVOKE 5-63	Cellular Geographical Service Area 1-16
7	InterSystemPage 6-175	Cellular Messaging Teleservice
8	InterSystemPage INVOKE 5-72	SMS_TeleserviceIdentifier
9	InterSystemPage2 INVOKE 5-74	Cellular Paging Teleservice
10	CDMASWIN , 5-170	SMS_TeleserviceIdentifier
11	CDMATargetMAHOInformation 1-15, 5-124,	CFB , , (see Call ForwardingΔBusy)
12	CDMATargetMAHOList 5-173	DMH_RedirectionIndicator
13	FacilitiesDirective 6-118	FeatureRequest 3-237
14	HandoffBack 6-144	operations
15	HandoffToThird 6-156	LocationRequest 3-238
16	CDMATargetMAHOList 1-15, 2-11, 2-22, 2-36, 5-	RoutingRequest 3-238
17	124,	QualificationDirective 3-237
18	FacilitiesDirective 6-118	RedirectionRequest 3-240
19	FacilitiesDirective2 INVOKE 5-44	TransferToNumberRequest 3-240, 3-276
20	HandoffBack 6-144	CFB-FA
21	HandoffBack2 INVOKE 5-55	CallingFeaturesIndicator
22	HandoffToThird 6-156	CFD , , (see Call ForwardingΔDefault)
23	HandoffToThird2 INVOKE 5-63	DMH_RedirectionIndicator
24	CDMATargetMeasurementInformation 1-15, 5-124,	FeatureRequest 3-241
25	CDMATargetMeasurementList 5-174	LocationRequest 3-241
26	FacilitiesDirective 6-118	operations
27	HandoffBack 6-144	LocationRequest 3-242, 3-244
28	HandoffMeasurementRequest2 6-153	RoutingRequest 3-244
29	HandoffToThird 6-156	QualificationDirective 3-241
30	CDMATargetMeasurementList 1-15, 2-11, 2-22,	RedirectionRequest 3-241, 3-244
31	2-29, 2-36, 5-124,	RoutingRequest 3-241
32	FacilitiesDirective 6-118	TransferToNumberRequest 3-241, 3-244
33	FacilitiesDirective2 INVOKE 5-44	CFI , 5-153
34	HandoffBack 6-144	CFNA , , (see Call ForwardingΔNo
35	HandoffMeasurementRequest2 6-153	Answer)
36	HandoffToThird 6-156	DMH_RedirectionIndicator
37	HandoffToThird2 INVOKE 5-63	FeatureRequest 3-245
38	CDMATargetOneWayDelay 1-15, 5-121,	LocationRequest 3-245, 3-246
39	CDMATargetMAHOInformation 5-173	operations
40	CDMATargetMeasurementInformation 5-174	LocationRequest 3-271
41	HandoffMeasurementRequest2 6-153	RoutingRequest 3-271
42	CDMATOWD , 5-175	QualificationDirective 3-245
43	CDPointOfReturn 6-311, 6-312, 6-313, 6-314	RedirectionRequest 3-246, 3-271
44	CDRT	RoutingRequest 3-246
45	Celcore 5-300	TransferToNumberRequest 3-246, 3-271
46	Cell Site	CFNA-FA
47		CallingFeaturesIndicator
48		CFO
49		DMH_RedirectionIndicator
50		
51		
52		
53		
54		
55		
56		
57		
58		
59		
60		

CFU Unconditional)	HandoffToThird2 INVOKE 5-63	1
DMH_RedirectionIndicator	ChannelData (Target)	2
FeatureRequest 3-247	FacilitiesDirective RETURN RESULT 5-43	3
InformationDirective 3-249, 3-269	FacilitiesDirective2 RETURN RESULT 5-46	4
operations	HandoffBack RETURN RESULT 5-54	5
LocationRequest 3-249	HandoffBack2 RETURN RESULT 5-57	6
QualificationDirective 3-247	HandoffToThird RETURN RESULT 5-62	7
CFU-FA	HandoffToThird2 RETURN RESULT 5-65	8
CallingFeaturesIndicator	ChannelData parameter SCC field applies	9
CGSA	NAMPSChannelData	10
ChangedNumber	ChannelInfo1 2-6, 2-7, 2-10, 2-18, 2-21, 2-26, 2-28, 2-32, 2-35	11
AnnouncementCode, Standard Announcement	Chapter 4 6-249, 6-302, 6-401	12
Channel Number 1-16	FacilitiesRelease 6-125	13
Channel Number (CHNO)	Charge original destination 5-267	14
ChannelData 5-176	SMS_ChargeIndicator	15
ControlChannelData of the access channel being reported. The contents of this parameter are in accordance with AMPS, TDMA, and CDMA. 5-180	Charge original originator 5-267	16
TDMAChannelData 5-305	SMS_ChargeIndicator	17
ChannelData 1-16, 2-6, 2-7, 2-11, 2-12, 2-18, 2-21, 2-23, 2-26, 2-28, 2-32, 2-35, 2-37, 5-119, 5-218, 5-305, 5-306	CHDATA , 5-176	18
DTX	CHNO	19
HandoffMeasurementRequest 6-149	CHOICE	20
HandoffMeasurementRequest2 6-151	Class	21
DTX disabled	AnnouncementCode 5-133	22
HandoffMeasurementRequest 6-149	Class I	23
HandoffMeasurementRequest2 6-151	CDMAStationClassMark, Power Class	24
FacilitiesDirective 6-117, 6-118, 6-120, 6-121, 6-122	Class II	25
FacilitiesDirective (path minimization) 6-164, 6-165	CDMAStationClassMark, Power Class	26
HandoffBack 6-143, 6-144, 6-145, 6-147	Class III	27
HandoffMeasurementRequest 6-149, 6-151	CDMAStationClassMark, Power Class	28
HandoffMeasurementRequest2 6-151, 6-152	Class IV	29
HandoffToThird 6-156, 6-157, 6-158, 6-160, 6-161, 6-163	Class V	30
HandoffToThird2 6-160, 6-163	Class VI	31
ChannelData (Serving)	Class VII	32
FacilitiesDirective INVOKE 5-42	Class VIII	33
FacilitiesDirective2 INVOKE 5-44	Clear Trunk Timer 1-16, 4-24,	34
HandoffBack INVOKE 5-53	ClearDigits DigitMask	35
HandoffBack2 INVOKE 5-55	DigitCollectionControl 5-186	36
HandoffMeasurementRequest INVOKE 5-58	Clearinghouse	37
HandoffMeasurementRequest2 INVOKE 5-59	Cluster Number	38
HandoffToThird INVOKE 5-61	PC_SSN 5-230	39
	CMAC , 5-180	40
	ControlChannelData 5-180	41
	CMODES , 3-54, 5-179	42
	CNI 1-16	43
	CNIP , (see Calling Number Identification Presentation)	44
	InformationDirective 3-264	45
	InformationForward 3-262	46
	LocationRequest 3-255, 3-258, 3-260, 3-261,	47
		48
		49
		50
		51
		52
		53
		54
		55
		56
		57
		58
		59
		60

1	3-264, 3-265	other party disconnect 6-39
2	RoutingRequest 3-255, 3-258, 3-260, 3-261	Conference Calling (CC) procedures -
3	CNIP3--FA	ConferenceCallingIndicator 1-15, 5-124, , 6-
4	CallingFeaturesIndicator	337, 6-338
5	CNIP5--FA	FeatureRequest 6-127, 6-128
6	CallingFeaturesIndicator	FeatureRequest INVOKE 5-48
7	CNIR , 5-220, 5-221, , (see Calling	FeatureRequest RETURN RESULT 5-50
8	Number Identification Restriction)	MSC ActionCode Processing 6-24
9	FeatureRequest 3-266	originating call sent 6-22
10	loading of profile parameters 6-11	ConfidentialityModes 1-16, 2-6, 2-7, 2-12, 2-17,
11	LocationRequest 3-269	2-18, 2-23, 2-31, 2-32, 2-37, 5-43, 5-54, 5-62,
12	OneTimeFeatureIndicator 5-220	5-120, , 5-322
13	operations	(CMODES)
14	LocationRequest 3-274	AuthenticationRequest 6-84, 6-86, 6-92
15	CNIR-FA	(CMODES-actual)
16	CallingFeaturesIndicator	AuthenticationRequest 6-77, 6-80, 6-87
17	CNIR Active	FacilitiesDirective 6-118, 6-121
18	OneTimeFeatureIndicator, CNIR	FacilitiesDirective (path minimization) 6-
19	CNIR Inactive	165
20	OneTimeFeatureIndicator, CNIR	FlashRequest 6-138, 6-139
21	CNIROver-FA	HandoffBack 6-145, 6-146
22	CallingFeaturesIndicator	HandoffToThird 6-157, 6-158, 6-161, 6-
23	Code Division Multiple Access 1-15	162
24	coded ringing 5-131	(CMODES-desired)
25	Collect Digit	FacilitiesDirective 6-116, 6-117, 6-121
26	RemoteUserInteractionDirective 6-246	FacilitiesDirective (path minimization) 6-
27	Collect SPINI PIN	164
28	Color Code Indicator	HandoffBack 6-143, 6-146, 6-147
29	NAMPSChannelData 5-218	HandoffToThird 6-155, 6-158, 6-160, 6-
30	Commanded Disconnect	161, 6-162, 6-163
31	MSC ActionCode Processing 6-24	(Desired) 5-46, 5-57, 5-65
32	Common Channel Signaling 7	ConfidentialityModes (Actual)
33	Concurrent	AuthenticationRequest INVOKE 5-34
34	AnnouncementCode, Class	FacilitiesDirective RETURN RESULT 5-43
35	ConditionallyDeniedReason 1-15, 5-126, , 6-	FacilitiesDirective2 RETURN RESULT 5-46
36	310, 6-343, 6-344, 6-357	FlashRequest INVOKE 5-52
37	InterSystemPage RETURN RESULT 5-73	HandoffBack RETURN RESULT 5-54
38	RoutingRequest RETURN RESULT 5-101	HandoffBack2 RETURN RESULT 5-57
39	Waitable 6-310, 6-357	HandoffToThird RETURN RESULT 5-62
40	RoutingRequest 6-256, 6-257	HandoffToThird2 RETURN RESULT 5-65
41	Conference Call 5-178	ConfidentialityModes (Desired)
42	Conference Calling 1-15, 5-51	FacilitiesDirective INVOKE 5-42
43	bridge leg 5-129	FacilitiesDirective2 INVOKE 5-44
44	commanded disconnect 6-40	HandoffBack INVOKE 5-53
45	Drop Last Party	HandoffBack2 INVOKE 5-55
46	ActionCode	HandoffToThird INVOKE 5-61
47	maximum number of conferees 5-178	HandoffToThird2 INVOKE 5-63
48	MS termination alerting 6-32	Configuration Control and Failure Recovery. 4-28
49	MSC disconnect 6-39	ConfirmationTone
50		
51		
52		
53		
54		
55		
56		
57		
58		
59		
60		

AnnouncementCode, Tone	CountRequest procedures	-	1
CongestionTone	COUNTRPT	, 5-181	2
AnnouncementCode, Tone	CountUpdateReport	1-16, 3-38, 3-40, 5-125,	3
Continue processing			4
ActionCode	AuthenticationStatusReport	6-92	5
Continuous	AuthenticationStatusReport	INVOKE 5-36	6
CDMAStationClassMark, DTX	Count Update no response		7
StationClassMark	MSC receiving authentication parameters		8
Control Mobile Attenuation Code 1-16	6-57		9
ControlChannelData 5-180	Count Update not attempted		10
ControlChannelData 1-15, 3-115, 3-117, 3-120, 3-125, 5-96, 5-121, , 6-464, 6-465, 6-467, 6-468	MSC receiving authentication parameters		11
RegistrationCancellation 6-227	6-56		12
RegistrationCancellation INVOKE 5-92	COUNT update successful		13
RegistrationCancellation RETURN RESULT 5-93	MSC receiving authentication parameters		14
RegistrationNotification 6-233, 6-235, 6-237, 6-241, 6-242	6-57		15
RegistrationNotification INVOKE 5-94	courtesy call 6-315, 6-316, 6-318, 6-319, 6-322, 6-323, 6-326, 6-328, 6-397		16
RegistrationNotification RETURN RESULT 5-96	CourtesyCallWarning		17
Conventions	AnnouncementCode, Standard Announcement		18
Diagrammatic			19
Scenario Description			20
Coral Systems 5-300	CPNDGTS1	, 5-155	21
COUNT	CPNDGTS2	, 5-156	22
3-12, 3-23, 3-67, 3-85, 3-114, 5-152	CPNSTRG1	, 5-157	23
COUNT mismatch	CPNSTRG2	, 5-158	24
DenyAccess, Reason	CPSUB	, 5-159	25
ReportType	CRT	, 5-41,	26
Count Request Timer 1-16,	CSSInactive	5-80	27
COUNT Update 5-29, 5-33, 5-35, 5-36, 5-37 report 5-181	CT	, (see Call Transfer)	28
COUNT Update failure	in call MS flash attempt 6-14		29
DenyAccess, Reason	RoutingRequest	6-255	30
ReportType	CT-FA		31
Count Request Timer 1-16,	CallingFeaturesIndicator		32
COUNT Update 5-29, 5-33, 5-35, 5-36, 5-37 report 5-181	CTT	, 4-24, 5-47, 6-124, 6-125,	33
COUNT Update no response	CurrentServingInfo		34
CountUpdateReport	Set of parameters for Current Serving Information 2-28		35
ReportType	Custom Announcement 5-133		36
COUNT Update not attempted	AnnouncementCode 5-133		37
CountUpdateReport	CW	, (see Call Waiting)	38
COUNT Update successful	FeatureRequest 3-250, 3-251, 3-252		39
CountUpdateReport	in call MS flash attempt 6-14		40
COUNTEx	operations		41
3-46	LocationRequest 3-253		42
CountRequest 1-16, 5-6, 5-25, 5-27, , 6-401	RoutingRequest 3-253		43
operation definition 3-46-3-47, 5-41	QualificationDirective 3-250		44
operation usage	CW-FA		45
general 3-179, 3-192	CallingFeaturesIndicator		46
	CWFI		47
	OneTimeFeatureIndicator 5-220		48

1	CWIC	RegistrationNotification RETURN RESULT 5-
2	OneTimeFeatureIndicator 5-220	96
3		Deny0Minus
4		AnnouncementCode, Standard Announcement
5		
6	D	
7	<hr/>	
8	D reference point	Deny1plus
9	Data Circuit-Terminating Equipment 1-16	AnnouncementCode, Standard Announcement
10	Data Communications	Deny10XXX
11	Data Link Performance. 4-28	AnnouncementCode, Standard Announcement
12	Data Message Handling 1-16	
13	Data Numbering	Deny10XXXLocally
14	DigitsType, Numbering Plan	AnnouncementCode, Standard Announcement
15	Data Terminating Equipment 1-16	
16	Data Terminating or Data Circuit-Terminating	Deny10Plus
17	Equipment 1-16	AnnouncementCode, Standard Announcement
18	Days	
19	AuthorizationPeriod	DenyAccess 1-16, 3-20, 3-25, 3-39, 5-121,
20	DeniedAuthorizationPeriod	AuthenticationDirective INVOKE 5-29
21	DCC	AuthenticationFailureReport 6-63, 6-69, 6-73
22	ControlChannelData 5-180	AuthenticationFailureReport RETURN RESULT
23	DCE	5-33
24	DEFAULT	AuthenticationRequest 6-81, 6-84, 6-86, 6-87,
25	MSC Routing Points of Return 6-21	6-91
26	SMS_OriginationRestrictions 5-282	AuthenticationRequest RETURN RESULT 5-
27	SMS_TerminationRestrictions 5-285	35
28	Delinquent account	AuthenticationStatusReport 6-94, 6-100
29	AuthorizationDenied, Reason	AuthenticationStatusReport RETURN RESULT
30	SMSNotification 6-287	5-37
31	SMSRequest 6-291, 6-293, 6-295	AUTHR mismatch
32	DENACC , 5-183	AuthenticationRequest 6-89
33	DENAUTHPER , 3-95, 3-103, 3-125, 5-182	COUNT mismatch
34	DenialToneBurst	AuthenticationRequest 6-88, 6-89
35	AnnouncementCode, Tone	MIN or ESN authentication failure
36	Denied	AuthenticationRequest 6-87
37	AlertResult	Missing authentication parameters
38	SMS_AccessDeniedReason	AuthenticationRequest 6-88
39	denied authorization period	MSC receiving authentication parameters 6-53
40	QualificationDirective 6-206	TerminalType mismatch
41	QualificationRequest 6-212, 6-213	AuthenticationRequest 6-87
42	RegistrationNotification 6-235, 6-238	Unspecified
43	DeniedAuthorizationPeriod 1-16, 5-84, 5-87, 5-96,	AuthenticationFailureReport 6-66, 6-68,
44	5-126,	6-69, 6-72
45	AuthenticationRequest 6-78	AuthenticationRequest 6-78
46	QualificationDirective 6-205, 6-206	AuthenticationStatusReport 6-97, 6-98,
47	QualificationDirective INVOKE 5-84	6-100, 6-103
48	QualificationRequest 6-212, 6-213, 6-216	DenyIncomingToll
49	QualificationRequest RETURN RESULT 5-87	AnnouncementCode, Standard Announcement
50	RegistrationNotification 6-238, 6-242	
51		
52		
53		
54		
55		
56		
57		
58		
59		
60		

DenyInternationalOrigination	Di reference point	1
AnnouncementCode, Standard Announcement	Diagrammatic Conventions	2
	Dialed Number	3
DenyNumber	DigitsType, Type of Digits	4
AnnouncementCode, Standard Announcement	Dialogue	5
	DMH_RedirectionIndicator	6
DenyTermination	Dialogue Termination	7
AnnouncementCode, Standard Announcement	TerminationTreatment	8
	DialogueTermination	9
DenyTollOrigination	MSC Routing Points of Return 6-21	10
AnnouncementCode, Standard Announcement	DialTone	11
	AnnouncementCode, Tone	12
DEREG , 3-84, 5-184	DialToneBurst	13
Deregister due to MS power down	AnnouncementCode, Tone	14
DeregistrationType	Digit	15
Deregister for an administrative reason	DigitsType	16
DeregistrationType	Digital Color Code 1-16	17
Deregister for an unspecified reason	ControlChannelData 5-180	18
DeregistrationType	Digital Equipment Corp 5-300	19
deregistration 5-296	Digital Mobile Attenuation Code 1-16	20
DeregistrationType 1-16, 3-84, 3-85, 5-122,	Digital SAT Color Code	21
MSInactive 6-195, 6-197, 6-198	NAMPSChannelData	22
MSInactive INVOKE 5-80	Digital Verification Color Code 1-16	23
Destination busy 5-264	DigitalChannelData 5-305	24
SMS_CauseCode	DigitCollectionControl 1-16, 5-125, , 6-365,	25
Destination no longer at this address	6-369, 6-380, 6-381, 6-382, 6-383, 6-384, 6-	26
SMS_CauseCode	385, 6-386, 6-388, 6-389, 6-392	27
Destination Number	RemoteUserInteractionDirective 6-245	28
DigitsType, Type of Digits	RemoteUserInteractionDirective INVOKE 5-97	29
Destination out of service 5-264	DigitMask 5-187	30
SMS_CauseCode	Digits 5-52, 5-119, , 6-344	31
Destination Point Code 1-16	(Carrier) 6-309, 6-314	32
Destination resource shortage	loading of profile parameters 6-10	33
SMS_CauseCode	LocationRequest 6-193	34
DestinationAddress 6-411, 6-412	MSC route the call externally 6-35	35
DestinationDigits 5-122, , 5-236, 6-21, 6-313,	QualificationDirective 6-207, 6-210	36
6-395, 6-398	QualificationRequest 6-215, 6-217	37
IntersystemTermination 5-206	RedirectionDirective 6-220	38
LocalTermination 5-208	(Redirection) 6-312, 6-313, 6-343, 6-357, 6-	39
MSC route the call externally 6-36	358, 6-395, 6-397, 6-398	40
MSC Routing Points of Return 6-21	InterSystemPage 6-178	41
RoutingRequest 6-258	loading of profile parameters 6-11	42
RoutingRequest INVOKE 5-99	LocationRequest 6-189	43
DestinationSubaddress 6-412	MSC route the call externally 6-36, 6-37	44
Detection of Dual Seizure 4-20	QualificationDirective 6-207, 6-210	45
DGTCC , 3-127, 3-128, 5-186	QualificationRequest 6-215, 6-217	46
DGTSDEST 3-62, 3-107, 3-132, 3-159	RedirectionDirective 6-220, 6-222	47
DGTSDIAL , 3-27, 3-50, 3-52, 3-54, 3-74, 3-	RedirectionRequest 6-225	48
87, 3-127	RoutingRequest 6-257, 6-258, 6-259	49

1	TransferToNumberRequest 6-297	5-111
2	UnsolicitedResponse 6-304	UnsolicitedResponse INVOKE 5-117
3	(Dialed) 6-365, 6-369, 6-370, 6-374, 6-375, 6-	Digits (Dialed)
4	380, 6-381, 6-382, 6-383, 6-384, 6-385, 6-	AuthenticationRequest INVOKE 5-34
5	386, 6-388, 6-389, 6-390, 6-391, 6-392, 6-	FeatureRequest INVOKE 5-48
6	393	FlashRequest INVOKE 5-52
7	AuthenticationFailureReport 6-66, 6-68,	LocationRequest INVOKE 5-77
8	6-71	OriginationRequest INVOKE 5-81, 5-82
9	AuthenticationRequest 6-77, 6-79, 6-84,	RemoteUserInteractionDirective RETURN
10	6-86, 6-87, 6-88, 6-91, 6-92	RESULT 5-97
11	AuthenticationStatusReport 6-97, 6-99,	Digits Dialed 1-16
12	6-103	Digits(Carrier) 3-75, 3-76, 3-77, 3-79, 3-93, 3-100,
13	FeatureRequest 6-127, 6-128, 6-130, 6-	3-121, 3-155
14	135, 6-136, 6-137, 6-138	Digits(Destination) 3-75, 3-76, 3-77, 3-155
15	FeatureRequest RETURN RESULT 5-50	Digits(Restriction) 3-92, 3-100, 3-120
16	FlashRequest 6-138, 6-139, 6-140, 6-142	DigitsType 5-155, 5-156, 5-157, 5-158, 5-162, 5-
17	LocationRequest 6-188, 6-191, 6-194, 6-	185, 5-189, 5-191, 5-192, 5-193, 5-212, 5-215,
18	195	5-232, 5-242, 5-243, 5-248, 5-249, 5-251, 5-
19	MSC analyze MS dialed number 6-15, 6-	258, 5-259, 5-260, 5-268, 5-269, 5-272, 5-273,
20	16, 6-17	5-274, 5-276, 5-277, 5-278, 5-280, 5-281, 5-
21	OriginationRequest 6-201, 6-204	286, 5-320, 5-321,
22	RemoteUserInteractionDirective 6-245, 6-	DIRECT
23	246, 6-247, 6-248	SMS_OriginationRestrictions 5-282
24	InterSystemPage 6-176	Directory Number 1-16
25	page an MS 6-28	discard message on error 5-8, 5-11
26	unknown	Discard SSD
27	MSC analyze MS dialed number 6-15, 6-	SSDNotShared
28	16, 6-17	Disconnect all call legs
29	Digits (Carrier)	ActionCode
30	LocationRequest RETURN RESULT 5-78	Disconnect call
31	QualificationDirective INVOKE 5-84	ActionCode
32	QualificationRequest RETURN RESULT 5-87	Disconnect call leg
33	RedirectionDirective INVOKE 5-89	ActionCode
34	RegistrationNotification RETURN RESULT 5-	disconnect call task procedures 6-39-6-40
35	96	Disconnect Call Tasks
36	TransferToNumberRequest RETURN RESULT	DisconnectedNumber
37	5-111	AnnouncementCode, Standard Announcement
38	Digits (Destination) 5-73, 5-222	Discontinue
39	InterSystemPage RETURN RESULT 5-73	CancellationType
40	LocationRequest RETURN RESULT 5-78	Discontinuous
41	network destination 5-190	CDMAStationClassMark, DTX
42	profile restriction	StationClassMark
43	QualificationDirective INVOKE 5-84	Discontinuous Transmission Mode 5-176
44	QualificationRequest RETURN RESULT 5-87	distinctive alerting 1 5-131
45	RedirectionDirective INVOKE 5-89	distinctive alerting 2 5-131
46	RegistrationNotification RETURN RESULT 5-	distinctive alerting 3 5-131
47	96	DMAC
48	RoutingRequest RETURN RESULT 5-101	TDMChannelData 5-305
49	TransferToNumberRequest RETURN RESULT	
50		
51		
52		
53		
54		
55		
56		
57		
58		
59		
60		

DMH , , 6-34	loading of profile parameters 6-10	1
FacilitiesRelease 6-124, 6-125	LocationRequest RETURN RESULT 5-78	2
DMH_AccountCodeDigits 1-14, 3-50, 3-52, 3-62,	MSC record the DMH parameters 6-34	3
3-75, 3-81, 3-87, 3-88, 3-93, 3-100, 3-121, 3-	OriginationRequest RETURN RESULT 5-82	4
132, 3-155, 3-156, 3-160, 5-125, , 6-309	Profile 5-234	5
FeatureRequest RETURN RESULT 5-50	QualificationDirective INVOKE 5-234	6
InterSystemPage INVOKE 5-72	QualificationRequest RETURN RESULT 5-234	7
loading of profile parameters 6-10	RedirectionDirective 6-221	8
LocationRequest RETURN RESULT 5-78	RedirectionDirective INVOKE 5-89	9
MSC record the DMH parameters 6-34	RegistrationNotification RETURN RESULT 5-	10
OriginationRequest RETURN RESULT 5-82	234	11
Profile 5-234	RoutingRequest INVOKE 5-99	12
QualificationDirective INVOKE 5-234	TransferToNumberRequest RETURN RESULT	13
QualificationRequest RETURN RESULT 5-234	5-111	14
RedirectionDirective 6-221	UnsolicitedResponse RETURN RESULT 5-118	15
RedirectionDirective INVOKE 5-89	DMH_RedirectionIndicator 1-20, 3-75, 3-87, 3-155,	16
RegistrationNotification RETURN RESULT 5-	5-122,	17
234	CD\\local 6-309	18
RoutingRequest INVOKE 5-99	CD\\Private 6-312	19
TransferToNumberRequest RETURN RESULT	CD\\PSTN 6-312	20
5-111	CD\\unspecified 6-312	21
UnsolicitedResponse RETURN RESULT 5-118	CFB 6-315, 6-316, 6-317	22
DMH_AlternateBillingDigits 1-14, 3-50, 3-52, 3-62,	CFD 6-318, 6-319, 6-320, 6-321	23
3-75, 3-81, 3-87, 3-88, 3-93, 3-100, 3-121, 3-	CFNA 6-322, 6-324, 6-325	24
132, 3-155, 3-156, 3-160, 5-125, , 5-193,	CFU 6-326, 6-328, 6-329	25
6-309	FeatureRequest RETURN RESULT 5-50	26
FeatureRequest RETURN RESULT 5-50	LocationRequest RETURN RESULT 5-78	27
InterSystemPage INVOKE 5-72	MSC record the DMH parameters 6-34	28
loading of profile parameters 6-10	OriginationRequest RETURN RESULT 5-82	29
LocationRequest RETURN RESULT 5-78	PCA call refused 6-366	30
MSC record the DMH parameters 6-34	SCA call refused 6-379, 6-380	31
OriginationRequest RETURN RESULT 5-82	TransferToNumberRequest RETURN RESULT	32
Profile 5-234	5-111	33
QualificationDirective INVOKE 5-234	Voice Mail Retrieval 6-394, 6-395	34
QualificationRequest RETURN RESULT 5-234	DN	35
RedirectionDirective 6-221	DND , 6-320, 6-324, 6-329, , (see Do	36
RedirectionDirective INVOKE 5-89	Not Disturb)	37
RegistrationNotification RETURN RESULT 5-	FeatureRequest 3-285	38
234	LocationRequest 3-285, 3-286	39
RoutingRequest INVOKE 5-99	QualificationDirective 3-285	40
TransferToNumberRequest RETURN RESULT	RedirectionRequest 3-286	41
5-111	RoutingRequest 3-286	42
UnsolicitedResponse RETURN RESULT 5-118	TransferToNumberRequest 3-286	43
DMH_BillingDigits 1-15, 3-50, 3-52, 3-62, 3-75, 3-	Do Not Disturb 1-16	44
81, 3-87, 3-88, 3-93, 3-100, 3-121, 3-132, 3-	Do Not Disturb (DND) procedures -	45
155, 3-156, 3-160, 5-125, 5-192, , 6-35, 6-	Do not notify when available 5-271	46
309	SMS_NotificationIndicator	47
FeatureRequest RETURN RESULT 5-50	Double Star	48
InterSystemPage INVOKE 5-72	OriginationTriggers	49

1	SPINTriggers	52
2	DP	AuthenticationDirective INVOKE 5-29
3	OriginationTriggers	AuthenticationDirectiveForward 6-60
4	DPC	AuthenticationFailureReport 6-66, 6-69, 6-72
5	DQPSK 5-304	AuthenticationFailureReport INVOKE 5-32
6	Drop call leg on busy or routing failure	AuthenticationRequest 6-78, 6-87
7	ActionCode	AuthenticationRequest INVOKE 5-34
8	DS	AuthenticationStatusReport 6-97, 6-100, 6-
9	OriginationTriggers	103
10	DSC 5-300	AuthenticationStatusReport INVOKE 5-36
11	DTE	BaseStationChallenge 6-104, 6-106, 6-108, 6-
12	DTX disabled	109
13	ChannelData	BaseStationChallenge INVOKE 5-38
14	DTX mode active or acceptable	CountRequest 6-111, 6-114, 6-115
15	ChannelData	CountRequest INVOKE 5-41
16	DTX-low mode	FacilitiesDirective 6-118
17	ChannelData	FacilitiesDirective (path minimization) 6-164
18	dual seizure 4-20	FacilitiesDirective INVOKE 5-42
19	Dual-mode CDMA	FacilitiesDirective2 INVOKE 5-44
20	CDMAStationClassMark	FeatureRequest 6-127, 6-137
21	Dual-mode Indicator	FeatureRequest INVOKE 5-48
22	CDMAStationClassMark 5-172	FlashRequest 6-138, 6-140, 6-142
23	Duplicate unit	FlashRequest INVOKE 5-52
24	AuthorizationDenied, Reason	HandoffToThird 6-156, 6-161, 6-163
25	SMSNotification 6-287	HandoffToThird INVOKE 5-61
26	SMSRequest 6-291, 6-294, 6-295	HandoffToThird2 INVOKE 5-63
27	DVCC	InformationDirective 6-166, 6-168, 6-170
28	TDMChannelData 5-305	InformationDirective INVOKE 5-66
29	DXE	InformationForward 6-170, 6-171
30		InformationForward INVOKE 5-68
31		InterSystemAnswer INVOKE 5-70
32		InterSystemPage 6-175, 6-179
33		InterSystemPage INVOKE 5-72
34		InterSystemPage2 6-184
35		InterSystemPage2 INVOKE 5-74
36		InterSystemSetup 6-185
37		InterSystemSetup INVOKE 5-76
38		IntersystemTermination 5-206
39		LocalTermination 5-208
40		LocationRequest RETURN RESULT 5-78
41		MSC record the DMH parameters 6-34
42		MSC route the call externally 6-35, 6-36, 6-37
43		MSInactive 6-195, 6-196, 6-197, 6-198, 6-199,
44		6-200
45		MSInactive INVOKE 5-80
46		OriginationRequest 6-201, 6-205
47		OriginationRequest INVOKE 5-81
48		QualificationDirective 6-205, 6-207, 6-208, 6-
49		210
50		
51		
52		
53		
54		
55		
56		
57		
58		
59		
60		

E

E reference point

ECSA

ECT

 DMH_RedirectionIndicator

EDS 5-300

Effective Radiated Power 1-16

EIA

EIR , 1-24,

 ExtendedMSCID, type

 ExtendedSystemMyTypeCode

 PC_SSN, Type

Electronic Industries Association 1-16

ElectronicSerialNumber 1-16, 5-119, , 5-236,

6-309, 6-310, 6-342, 6-356, 6-394, 6-395, 6-411,

6-412, 6-414

 AuthenticationDirective 6-42, 6-46, 6-50, 6-

QualificationDirective INVOKE 5-84	AnnouncementCode, Standard Announcement	1
QualificationRequest 6-210, 6-215, 6-217		2
QualificationRequest INVOKE 5-86	EnterOldPINSendPrompt	3
RedirectionDirective 6-223	AnnouncementCode, Standard Announcement	4
RedirectionDirective INVOKE 5-89		5
RedirectionRequest 6-225	EnterPasswordPrompt	6
RedirectionRequest INVOKE 5-91	AnnouncementCode, Standard Announcement	7
RegistrationCancellation 6-226, 6-229, 6-232		8
RegistrationCancellation INVOKE 5-92	EnterPINPrompt	9
RegistrationNotification 6-233, 6-240, 6-244	AnnouncementCode, Standard Announcement	10
RegistrationNotification INVOKE 5-94		11
RoutingRequest 6-250, 6-253, 6-257, 6-258, 6-260	EnterPINSendPrompt	12
RoutingRequest INVOKE 5-99	AnnouncementCode, Standard Announcement	13
SMSDeliveryBackward INVOKE 5-102		14
SMSDeliveryForward INVOKE 5-104	Entity Relationship Diagram	15
SMSDeliveryPointToPoint 6-267, 6-268, 6-269, 6-271, 6-274, 6-282	ENUMERATED	16
SMSDeliveryPointToPoint INVOKE 5-106	Equipment Identity Register 1-16, 1-24, Ericsson 5-300	17
SMSNotification 6-285, 6-286, 6-287	ERP	18
SMSNotification INVOKE 5-108	Error code 5-20, 5-21, 5-199	19
SMSRequest 6-288, 6-289, 6-291, 6-293, 6-295	AuthenticationDirective 6-45, 6-49	20
SMSRequest INVOKE 5-109	AuthenticationDirectiveForward 6-61	21
SMSRequest RETURN RESULT 5-109	AuthenticationFailureReport 6-65, 6-67, 6-68	22
TransferToNumberRequest 6-296, 6-302	AuthenticationRequest 6-83, 6-84, 6-85	23
TransferToNumberRequest INVOKE 5-110	AuthenticationStatusReport 6-96, 6-98	24
UnsolicitedResponse 6-307	BaseStationChallenge 6-105, 6-107	25
UnsolicitedResponse INVOKE 5-117	BulkDeregistration 6-110	26
Encoding problem	CountRequest 6-112	27
SMS_CauseCode	FacilitiesDirective 6-121	28
English	FacilitiesRelease 6-126	29
PreferredLanguageIndicator	FeatureInactive	30
Enter Feature Code , 6-374	AuthenticationDirective 6-46, 6-50, 6-51	31
EnterDigits DigitMask	AuthenticationDirectiveForward 6-60	32
DigitCollectionControl 5-186	AuthenticationFailureReport 6-66, 6-68, 6-71	33
EnterDirectoryNumberPrompt	AuthenticationRequest 6-84, 6-86, 6-91	34
AnnouncementCode, Standard Announcement	AuthenticationStatusReport 6-97, 6-99, 6-103	35
EnterFeatureCodePrompt	BaseStationChallenge 6-106, 6-108, 6-109	36
AnnouncementCode, Standard Announcement	BulkDeregistration 6-111	37
EnterNewPINPrompt	CountRequest 6-113, 6-115	38
AnnouncementCode, Standard Announcement	FacilitiesDirective 6-122	39
EnterNewPINSendPrompt	FacilitiesRelease 6-126	40
AnnouncementCode, Standard Announcement	FeatureRequest 6-137	41
EnterOldPINPrompt	FlashRequest 6-140, 6-142	42
	HandoffBack 6-147	43
	HandoffMeasurementRequest 6-150	44
	HandoffMeasurementRequest2 6-154	45
		46
		47
		48
		49
		50
		51
		52
		53
		54
		55
		56
		57
		58
		59
		60

1	HandoffToThird 6-160, 6-163	HandoffBack 6-147
2	InformationDirective 6-168, 6-169	HandoffMeasurementRequest 6-150
3	InformationForward 6-172	HandoffMeasurementRequest2 6-154
4	InterSystemAnswer 6-174	HandoffToThird 6-160, 6-163
5	InterSystemPage 6-179	InformationDirective 6-168, 6-169
6	InterSystemPage2 6-184	InformationForward 6-172
7	InterSystemSetup 6-187	InterSystemAnswer 6-174
8	LocationRequest 6-194	InterSystemPage 6-179
9	MSInactive 6-196, 6-199, 6-200	InterSystemPage2 6-184
10	OriginationRequest 6-204	InterSystemSetup 6-187
11	QualificationDirective 6-207, 6-209	LocationRequest 6-194
12	QualificationRequest 6-215, 6-217	MSInactive 6-196, 6-199, 6-200
13	RandomVariableRequest 6-220	OriginationRequest 6-204
14	RedirectionDirective 6-222	QualificationDirective 6-207, 6-209
15	RedirectionRequest 6-225	QualificationRequest 6-215, 6-217
16	RegistrationCancellation 6-229, 6-232	RandomVariableRequest 6-220
17	RegistrationNotification 6-240, 6-244	RedirectionDirective 6-222
18	RemoteUserInteractionDirective 6-248	RedirectionRequest 6-225
19	RoutingRequest 6-253, 6-260	RegistrationCancellation 6-229, 6-232
20	SMSNotification 6-287	RegistrationNotification 6-240, 6-244
21	SMSRequest 6-291, 6-293, 6-295	RemoteUserInteractionDirective 6-248
22	TransferToNumberRequest 6-301	RoutingRequest 6-253, 6-260
23	UnreliableRoamerDataDirective 6-303	SMSNotification 6-287
24	UnsolicitedResponse 6-307	SMSRequest 6-291, 6-293, 6-295
25	FeatureRequest 6-136	TransferToNumberRequest 6-301
26	FlashRequest 6-139, 6-141	UnreliableRoamerDataDirective 6-303
27	HandoffBack 6-146	UnsolicitedResponse 6-307
28	InformationDirective 6-167, 6-169	MissingParameter
29	InformationForward 6-171	AuthenticationDirective 6-46, 6-50, 6-51
30	InterSystemPage 6-178	AuthenticationDirectiveForward 6-60
31	InterSystemPage2 6-184	AuthenticationFailureReport 6-66, 6-68,
32	InterSystemSetup 6-186	6-71
33	LocationRequest 6-194	AuthenticationRequest 6-84, 6-86, 6-91
34	MIN/HLRMismatch	AuthenticationStatusReport 6-97, 6-99,
35	AuthenticationDirective 6-46, 6-50, 6-51	6-103
36	AuthenticationDirectiveForward 6-60	BaseStationChallenge 6-106, 6-108, 6-
37	AuthenticationFailureReport 6-66, 6-68,	109
38	6-71	BulkDeregistration 6-111
39	AuthenticationRequest 6-84, 6-86, 6-91	CountRequest 6-113, 6-115
40	AuthenticationStatusReport 6-97, 6-99,	FacilitiesDirective 6-122
41	6-103	FacilitiesRelease 6-126
42	BaseStationChallenge 6-106, 6-108, 6-	FeatureRequest 6-137
43	109	FlashRequest 6-140, 6-142
44	BulkDeregistration 6-111	HandoffBack 6-147
45	CountRequest 6-113, 6-115	HandoffMeasurementRequest 6-150
46	FacilitiesDirective 6-122	HandoffMeasurementRequest2 6-154
47	FacilitiesRelease 6-126	HandoffToThird 6-160, 6-163
48	FeatureRequest 6-137	InformationDirective 6-168, 6-169
49	FlashRequest 6-140, 6-142	InformationForward 6-172
50		
51		
52		
53		
54		
55		
56		
57		
58		
59		
60		

InterSystemAnswer 6-174	InterSystemSetup 6-187	
InterSystemPage 6-179	LocationRequest 6-194	1
InterSystemPage2 6-184	MSInactive 6-196, 6-199, 6-200	2
InterSystemSetup 6-187	OriginationRequest 6-204	3
LocationRequest 6-194	QualificationDirective 6-207, 6-209	4
MSInactive 6-196, 6-199, 6-200	QualificationRequest 6-215, 6-217	5
OriginationRequest 6-204	RandomVariableRequest 6-220	6
QualificationDirective 6-207, 6-209	RedirectionDirective 6-222	7
QualificationRequest 6-215, 6-217	RedirectionRequest 6-225	8
RandomVariableRequest 6-220	RegistrationCancellation 6-229, 6-232	9
RedirectionDirective 6-222	RegistrationNotification 6-240, 6-244	10
RedirectionRequest 6-225	RemoteUserInteractionDirective 6-248	11
RegistrationCancellation 6-229, 6-232	RoutingRequest 6-251, 6-253, 6-260	12
RegistrationNotification 6-240, 6-244	SMSNotification 6-287	13
RemoteUserInteractionDirective 6-248	SMSRequest 6-291, 6-293, 6-295	14
RoutingRequest 6-253, 6-258, 6-260	TransferToNumberRequest 6-301	15
SMSNotification 6-286, 6-287	UnreliableRoamerDataDirective 6-303	16
SMSRequest 6-291, 6-293, 6-295	UnsolicitedResponse 6-307	17
TransferToNumberRequest 6-301	OperationSequenceProblem 6-307	18
UnreliableRoamerDataDirective 6-303	AuthenticationDirective 6-45, 6-46, 6-49,	19
UnsolicitedResponse 6-307	6-50, 6-51	20
MSInactive 6-196, 6-198	AuthenticationDirectiveForward 6-60	21
OperationNotSupported	AuthenticationFailureReport 6-66, 6-68,	22
AuthenticationDirective 6-46, 6-50, 6-51	6-71	23
AuthenticationDirectiveForward 6-58, 6-59, 6-60	AuthenticationRequest 6-84, 6-86, 6-91	24
AuthenticationFailureReport 6-66, 6-68, 6-69, 6-71	AuthenticationStatusReport 6-96, 6-97,	25
AuthenticationRequest 6-84, 6-86, 6-87, 6-91	6-98, 6-99, 6-103	26
AuthenticationStatusReport 6-97, 6-99, 6-103	BaseStationChallenge 6-105, 6-106, 6-107, 6-108, 6-109	27
BaseStationChallenge 6-106, 6-108, 6-109	BulkDeregistration 6-111	28
BulkDeregistration 6-111	CountRequest 6-113, 6-115	29
CountRequest 6-113, 6-115	FacilitiesDirective 6-120, 6-122	30
FacilitiesDirective 6-122	FacilitiesRelease 6-126	31
FacilitiesRelease 6-126	FeatureRequest 6-137	32
FeatureRequest 6-137	FlashRequest 6-140, 6-142	33
FlashRequest 6-140, 6-142	HandoffBack 6-147	34
HandoffBack 6-147	HandoffMeasurementRequest 6-150	35
HandoffMeasurementRequest 6-150	HandoffMeasurementRequest2 6-154	36
HandoffMeasurementRequest2 6-154	HandoffToThird 6-160, 6-163	37
HandoffToThird 6-160, 6-163	InformationDirective 6-168, 6-169	38
InformationDirective 6-168, 6-169	InformationForward 6-171, 6-172	39
InformationForward 6-172	InterSystemAnswer 6-174	40
InterSystemAnswer 6-174	InterSystemPage 6-179	41
InterSystemPage 6-179	InterSystemPage2 6-184	42
InterSystemPage2 6-184	InterSystemSetup 6-187	43
InterSystemSetup 6-187	LocationRequest 6-194	44
LocationRequest 6-194	MSInactive 6-196, 6-199, 6-200	45
MSInactive 6-196, 6-199, 6-200	OriginationRequest 6-204	46
OriginationRequest 6-204	QualificationDirective 6-207, 6-209	47
QualificationDirective 6-207, 6-209		48
		49
		50
		51
		52
		53
		54
		55
		56
		57
		58
		59
		60

1	QualificationRequest 6-214, 6-215, 6-217	RedirectionDirective 6-222
2	RandomVariableRequest 6-220	RedirectionRequest 6-225
3	RedirectionDirective 6-222	RegistrationCancellation 6-228, 6-229, 6-
4	RedirectionRequest 6-225	232
5	RegistrationCancellation 6-228, 6-229, 6-	RegistrationNotification 6-239, 6-240, 6-
6	232	244
7	RegistrationNotification 6-239, 6-240, 6-	RemoteUserInteractionDirective 6-248
8	244	RoutingRequest 6-252, 6-253, 6-260
9	RemoteUserInteractionDirective 6-248	SMSNotification 6-287
10	RoutingRequest 6-252, 6-253, 6-260	SMSRequest 6-291, 6-292, 6-293, 6-295
11	SMSNotification 6-287	TransferToNumberRequest 6-301
12	SMSRequest 6-291, 6-292, 6-293, 6-295	UnreliableRoamerDataDirective 6-303
13	TransferToNumberRequest 6-301	UnsolicitedResponse 6-307
14	UnreliableRoamerDataDirective 6-303	QualificationDirective 6-206, 6-209
15	OriginationRequest 6-203	QualificationRequest 6-214, 6-216
16	ParameterError 6-65	RandomVariableRequest 6-219
17	AuthenticationDirective 6-45, 6-46, 6-49,	RedirectionDirective 6-222
18	6-50, 6-51	RedirectionRequest 6-224
19	AuthenticationDirectiveForward 6-60	RegistrationCancellation 6-228, 6-231
20	AuthenticationFailureReport 6-65, 6-66,	RegistrationNotification 6-235, 6-239, 6-243
21	6-67, 6-68, 6-71	ResourceShortage
22	AuthenticationRequest 6-83, 6-84, 6-85,	AuthenticationDirective 6-46, 6-50, 6-51
23	6-86, 6-91	AuthenticationDirectiveForward 6-60
24	AuthenticationStatusReport 6-96, 6-97,	AuthenticationFailureReport 6-66, 6-68,
25	6-98, 6-99, 6-103	6-71
26	BaseStationChallenge 6-105, 6-106, 6-	AuthenticationRequest 6-84, 6-86, 6-91
27	107, 6-108, 6-109	AuthenticationStatusReport 6-97, 6-99,
28	BulkDeregistration 6-111	6-103
29	CountRequest 6-112, 6-113, 6-115	BaseStationChallenge 6-106, 6-108, 6-
30	FacilitiesDirective 6-122	109
31	FacilitiesRelease 6-126	BulkDeregistration 6-111
32	FeatureRequest 6-137	CountRequest 6-113, 6-115
33	FlashRequest 6-140, 6-142	FacilitiesDirective 6-121, 6-122
34	HandoffBack 6-147	FacilitiesRelease 6-126
35	HandoffMeasurementRequest 6-150	FeatureRequest 6-137
36	HandoffMeasurementRequest2 6-154	FlashRequest 6-140, 6-142
37	HandoffToThird 6-160, 6-163	HandoffBack 6-146, 6-147
38	InformationDirective 6-168, 6-169	HandoffMeasurementRequest 6-150
39	InformationForward 6-171, 6-172	HandoffMeasurementRequest2 6-154
40	InterSystemAnswer 6-174	HandoffToThird 6-158, 6-160, 6-162, 6-
41	InterSystemPage 6-179	163
42	InterSystemPage2 6-184	InformationDirective 6-168, 6-169
43	InterSystemSetup 6-187	InformationForward 6-172
44	LocationRequest 6-194	InterSystemAnswer 6-174
45	MSInactive 6-196, 6-199, 6-200	InterSystemPage 6-178, 6-179
46	OriginationRequest 6-204	InterSystemPage2 6-184
47	QualificationDirective 6-207, 6-209	InterSystemSetup 6-187
48	QualificationRequest 6-214, 6-215, 6-217	LocationRequest 6-194
49	RandomVariableRequest 6-220	MSInactive 6-196, 6-199, 6-200
50		
51		
52		
53		
54		
55		
56		
57		
58		
59		
60		

OriginationRequest 6-204	OriginationRequest 6-203, 6-204	1
QualificationDirective 6-207, 6-209	QualificationDirective 6-207, 6-209	2
QualificationRequest 6-215, 6-217	QualificationRequest 6-213, 6-214, 6-215, 6-217	3
RandomVariableRequest 6-220	RandomVariableRequest 6-220	4
RedirectionDirective 6-222	RedirectionDirective 6-222	5
RedirectionRequest 6-225	RedirectionRequest 6-225	6
RegistrationCancellation 6-229, 6-232	RegistrationCancellation 6-228, 6-229, 6-232	7
RegistrationNotification 6-240, 6-244	RegistrationNotification 6-239, 6-240, 6-244	8
RemoteUserInteractionDirective 6-248	RemoteUserInteractionDirective 6-248	9
RoutingRequest 6-253, 6-259, 6-260	RoutingRequest 6-251, 6-252, 6-253, 6-260	10
SMSNotification 6-287	SMSNotification 6-287	11
SMSRequest 6-291, 6-293, 6-295	SMSRequest 6-291, 6-292, 6-293, 6-295	12
TransferToNumberRequest 6-301	TransferToNumberRequest 6-301	13
UnreliableRoamerDataDirective 6-303	UnreliableRoamerDataDirective 6-303	14
UnsolicitedResponse 6-307	UnsolicitedResponse 6-307	15
RoutingRequest 6-252, 6-260	TransferToNumberRequest 6-301	16
SMSNotification 6-286	TrunkUnavailable	17
SMSRequest 6-290, 6-292, 6-293, 6-294	AuthenticationDirective 6-46, 6-50, 6-51	18
SystemFailure 6-65, 6-314	AuthenticationDirectiveForward 6-60, 6-61	19
AuthenticationDirective 6-45, 6-46, 6-49, 6-50, 6-51	AuthenticationFailureReport 6-65, 6-66, 6-67, 6-68, 6-71	20
AuthenticationDirectiveForward 6-60, 6-61	AuthenticationRequest 6-83, 6-84, 6-85, 6-86, 6-91	21
AuthenticationFailureReport 6-65, 6-66, 6-67, 6-68, 6-71	AuthenticationStatusReport 6-96, 6-97, 6-98, 6-99, 6-103	22
AuthenticationRequest 6-83, 6-84, 6-85, 6-86, 6-91	BaseStationChallenge 6-105, 6-106, 6-107, 6-108, 6-109	23
AuthenticationStatusReport 6-96, 6-97, 6-98, 6-99, 6-103	BulkDeregistration 6-111	24
BaseStationChallenge 6-105, 6-106, 6-107, 6-108, 6-109	CountRequest 6-113, 6-115	25
BulkDeregistration 6-111	FacilitiesDirective 6-122	26
CountRequest 6-113, 6-115	FacilitiesDirective (path minimization) 6-165, 6-166	27
FacilitiesDirective 6-122	FacilitiesRelease 6-126	28
FacilitiesRelease 6-126	FeatureRequest 6-137	29
FeatureRequest 6-137	FlashRequest 6-140, 6-142	30
FlashRequest 6-140, 6-141, 6-142	HandoffBack 6-147	31
HandoffBack 6-147	HandoffMeasurementRequest 6-150	32
HandoffMeasurementRequest 6-150	HandoffMeasurementRequest2 6-154	33
HandoffMeasurementRequest2 6-154	HandoffToThird 6-160, 6-163	34
HandoffToThird 6-160, 6-163	InformationDirective 6-167, 6-168, 6-169	35
InformationDirective 6-167, 6-168, 6-169	InformationForward 6-171, 6-172	36
InformationForward 6-171, 6-172	InterSystemAnswer 6-174	37
InterSystemAnswer 6-174	InterSystemPage 6-179	38
InterSystemPage 6-179	InterSystemPage2 6-184	39
InterSystemPage2 6-184	InterSystemSetup 6-187	40
InterSystemSetup 6-187	LocationRequest 6-193, 6-194	41
LocationRequest 6-193, 6-194	MSInactive 6-196, 6-199, 6-200	42
MSInactive 6-196, 6-199, 6-200		43

1 LocationRequest 6-194
 2 MSInactive 6-196, 6-199, 6-200
 3 OriginationRequest 6-204
 4 QualificationDirective 6-207, 6-209
 5 QualificationRequest 6-215, 6-217
 6 RandomVariableRequest 6-220
 7 RedirectionDirective 6-222
 8 RedirectionRequest 6-225
 9 RegistrationCancellation 6-229, 6-232
 10 RegistrationNotification 6-240, 6-244
 11 RemoteUserInteractionDirective 6-248
 12 RoutingRequest 6-253, 6-260
 13 SMSNotification 6-287
 14 SMSRequest 6-291, 6-293, 6-295
 15 TransferToNumberRequest 6-301
 16 UnreliableRoamerDataDirective 6-303
 17 UnsolicitedResponse 6-307
 18
 19 UnrecognizedESN
 20 AuthenticationDirective 6-46, 6-50, 6-51
 21 AuthenticationDirectiveForward 6-60
 22 AuthenticationFailureReport 6-66, 6-68,
 23 6-71
 24 AuthenticationRequest 6-84, 6-86, 6-91
 25 AuthenticationStatusReport 6-97, 6-99,
 26 6-103
 27 BaseStationChallenge 6-106, 6-108, 6-
 28 109
 29 BulkDeregistration 6-111
 30 CountRequest 6-113, 6-115
 31 FacilitiesDirective 6-122
 32 FacilitiesRelease 6-126
 33 FeatureRequest 6-137
 34 FlashRequest 6-140, 6-142
 35 HandoffBack 6-147
 36 HandoffMeasurementRequest 6-150
 37 HandoffMeasurementRequest2 6-154
 38 HandoffToThird 6-160, 6-163
 39 InformationDirective 6-168, 6-169
 40 InformationForward 6-172
 41 InterSystemAnswer 6-174
 42 InterSystemPage 6-179
 43 InterSystemPage2 6-184
 44 InterSystemSetup 6-187
 45 LocationRequest 6-194
 46 MSInactive 6-196, 6-199, 6-200
 47 OriginationRequest 6-204
 48 QualificationDirective 6-207, 6-209
 49 QualificationRequest 6-215, 6-217
 50 RandomVariableRequest 6-220
 51 RedirectionDirective 6-222
 52 RedirectionRequest 6-225
 53 RegistrationCancellation 6-229, 6-232
 54 RegistrationNotification 6-240, 6-244
 55 RemoteUserInteractionDirective 6-248
 56 RoutingRequest 6-251, 6-253
 57
 58 RedirectionDirective 6-222
 59 RedirectionRequest 6-225
 60 RegistrationCancellation 6-229, 6-232
 RegistrationNotification 6-240, 6-244
 RemoteUserInteractionDirective 6-248
 RoutingRequest 6-253, 6-260
 SMSNotification 6-287
 SMSRequest 6-291, 6-293, 6-295
 TransferToNumberRequest 6-301
 UnreliableRoamerDataDirective 6-303
 UnsolicitedResponse 6-307
 UnrecognizedMIN 6-260
 AuthenticationDirective 6-46, 6-50, 6-51
 AuthenticationDirectiveForward 6-60
 AuthenticationFailureReport 6-66, 6-68,
 6-71
 AuthenticationRequest 6-84, 6-86, 6-91
 AuthenticationStatusReport 6-97, 6-99,
 6-103
 BaseStationChallenge 6-106, 6-108, 6-
 109
 BulkDeregistration 6-111
 CountRequest 6-113, 6-115
 FacilitiesDirective 6-122
 FacilitiesRelease 6-126
 FeatureRequest 6-137
 FlashRequest 6-140, 6-142
 HandoffBack 6-147
 HandoffMeasurementRequest 6-150
 HandoffMeasurementRequest2 6-154
 HandoffToThird 6-160, 6-163
 InformationDirective 6-168, 6-169
 InformationForward 6-172
 InterSystemAnswer 6-174
 InterSystemPage 6-179
 InterSystemPage2 6-184
 InterSystemSetup 6-187
 LocationRequest 6-194
 MSInactive 6-196, 6-199, 6-200
 OriginationRequest 6-204
 QualificationDirective 6-207, 6-209
 QualificationRequest 6-215, 6-217
 RandomVariableRequest 6-220
 RedirectionDirective 6-222
 RedirectionRequest 6-225
 RegistrationCancellation 6-229, 6-232
 RegistrationNotification 6-240, 6-244
 RemoteUserInteractionDirective 6-248
 RoutingRequest 6-251, 6-253

SMSNotification 6-287	UnsolicitedResponse 6-306	1
SMSRequest 6-291, 6-293, 6-295	Error Codes 5-22	2
TransferToNumberRequest 6-301	ESN , 2-5, 2-31, 3-8, 3-10, 3-12, 3-13, 3-15,	3
UnreliableRoamerDataDirective 6-303	3-16, 3-20, 3-23, 3-32, 3-38, 3-40, 3-42, 3-50,	4
UnsolicitedResponse 6-307	3-52, 3-54, 3-56, 3-58, 3-59, 3-61, 3-66, 3-71,	5
UnrecognizedParameterValue	3-75, 3-81, 3-83, 3-84, 3-85, 3-87, 3-90, 3-95,	6
AuthenticationDirective 6-46, 6-50, 6-51	3-96, 3-98, 3-107, 3-110, 3-113, 3-119, 3-131,	7
AuthenticationDirectiveForward 6-60	3-137, 3-141, 3-144, 3-148, 3-150, 3-154, 3-	8
AuthenticationFailureReport 6-66, 6-68,	159, 3-411, 3-413, 5-196	9
6-71	Even	10
AuthenticationRequest 6-84, 6-86, 6-91	Subaddress, O/E	11
AuthenticationStatusReport 6-97, 6-99,	Exchange Carrier Standards Association 1-16	12
6-103	executive override 5-131	13
BaseStationChallenge 6-106, 6-108, 6-	executive override and preemption 5-131	14
109	explicit call transfer	15
BulkDeregistration 6-111	DMH_RedirectionIndicator 5-195	16
CountRequest 6-113, 6-115	Extended modulation and framing	17
FacilitiesDirective 6-122	TDMACallMode	18
FacilitiesRelease 6-126	Extended Protocol Enhanced Services	19
FeatureRequest 6-137	SMS_TeleservicelIdentifier	20
FlashRequest 6-140, 6-142	ExtendedMSCID 1-16, 3-61, 3-159, 3-160, 5-121,	21
HandoffBack 6-147		22
HandoffMeasurementRequest 6-150	(Serving)	23
HandoffMeasurementRequest2 6-154	InterSystemPage 6-175	24
HandoffToThird 6-159, 6-160, 6-163	RegistrationNotification 6-237	25
InformationDirective 6-168, 6-169	type	26
InformationForward 6-172	Border MSC	27
InterSystemAnswer 6-174	UnsolicitedResponse 6-307	28
InterSystemPage 6-179	ExtendedMSCID (Border MSC)	29
InterSystemPage2 6-184	InterSystemPage RETURN RESULT 5-73	30
InterSystemSetup 6-187	UnsolicitedResponse INVOKE 5-117	31
LocationRequest 6-194	ExtendedMSCID (Originating MSC)	32
MSInactive 6-196, 6-199, 6-200	UnsolicitedResponse RETURN RESULT 5-118	33
OriginationRequest 6-204	ExtendedMSCID (Serving MSC)	34
QualificationDirective 6-207, 6-209	InterSystemPage INVOKE 5-72	35
QualificationRequest 6-215, 6-217	ExtendedMSCID (VLR)	36
RandomVariableRequest 6-220	RegistrationNotification INVOKE 5-94	37
RedirectionDirective 6-222	ExtendedSystemMyTypeCode 1-16, 3-61, 3-159,	38
RedirectionRequest 6-225	3-160, 5-121,	39
RegistrationCancellation 6-229, 6-232	ExtendedSystemMyTypeCode (Border MSC)	40
RegistrationNotification 6-240, 6-244	InterSystemPage RETURN RESULT 5-73	41
RemoteUserInteractionDirective 6-248	UnsolicitedResponse INVOKE 5-117	42
RoutingRequest 6-253, 6-258, 6-260	ExtendedSystemMyTypeCode (Originating MSC)	43
SMSNotification 6-287	UnsolicitedResponse RETURN RESULT 5-118	44
SMSRequest 6-291, 6-293, 6-295	ExtendedSystemMyTypeCode (Serving MSC)	45
TransferToNumberRequest 6-301	InterSystemPage INVOKE 5-72	46
UnreliableRoamerDataDirective 6-303	external network address	47
UnsolicitedResponse 6-307	MSC route the call externally 6-35	48
UnreliableRoamerDataDirective 6-303	EXTMSCID , 3-62, 5-197	49

1 EXTMYTYP , 5-198
2 EXTMYTYP 3-62
3
4
5
6 **F**
7
8 F reference point
9 FA , , (see Flexible Alerting)
10 DMH_RedirectionIndicator
11 FeatureRequest 3-287
12 LocationRequest 3-289, 3-292, 3-296, 3-303
13 OriginationRequest 3-301
14 QualificationDirective 3-287
15 RedirectionRequest 3-296
16 RoutingRequest 3-289, 3-292, 3-296, 3-304,
17 3-331
18 TransferToNumberRequest 3-296
19
20 FACDIR , , 2-3, 2-4, 2-5, 2-6, 2-7, 2-44,
21 2-50, 2-52, 2-58, 2-60, 2-62, 2-64, 2-66
22 FACDIR2 , 2-3, 2-9, 2-10, 2-12
23 FacDirParameterGroup 2-5
24 FacilitiesDirective 1-16, 1-17, 2-3, 2-4, 2-5, 2-8,
25 2-9, 2-42, 4-9, 4-10, 4-11, 4-12, 4-13, 4-15, 4-
26 16, 4-18, 4-20, 4-22, 4-23, 5-6, 5-11, 5-24, 5-
27 26, 5-27, , 5-43, 5-79, 5-179, 5-205, 6-401
28 FacilitiesDirective (path minimization) 6-164
29 operation definition 5-42-5-43
30 FacilitiesDirective procedures -
31 FacilitiesDirective2 1-16, 1-17, 2-3, 2-9, 2-10, 2-
32 13, 2-42, 4-15, 4-16, 4-18, 5-6, 5-25, 5-26, 5-
33 27, , 5-46, 5-79, 5-179, 5-205
34 FacilitiesDirective (path minimization) 6-164
35 operation definition 5-44-5-46
36 FacilitiesDirective2 procedures -
37 FacilitiesRelease 1-17, 2-3, 2-14, 4-9, 4-16, 4-18,
38 4-21, 4-23, 4-24, 5-6, 5-24, 5-27, , 5-246,
39 6-401
40 AuthenticationDirectiveForward 6-58
41 FacilitiesDirective 6-119, 6-120, 6-123
42 FacilitiesDirective (path minimization) 6-165
43 HandoffBack 6-145, 6-148
44 HandoffToThird 6-157, 6-159
45 InterSystemAnswer 6-173, 6-174
46 operation definition 5-47
47 FacilitiesRelease procedures -
48 FacilityProblem
49 AnnouncementCode, Standard Announcement
50
51 FACREL , 2-3, 2-14, 2-15, 2-46, 2-50, 2-52, 2-54, 2-56, 2-67, 2-68, 2-69, 2-70
52 Failed Call
53 TerminationTriggers
54 Failed Leg
55 TerminationTriggers
56 Failure
57 AlertResult
58 Failure in the Blocking and Unblocking Sequences
59 4-22
60 Failure to Receive a FacilitiesRelease RETURN
RESULT 4-24
FaultyParameter 5-19, 5-21, 5-23, 5-120,
AuthenticationDirectiveForward 6-61
Parameter Identifier 6-220, 6-307
AuthenticationDirective 6-46, 6-51, 6-52
AuthenticationDirectiveForward 6-60
AuthenticationFailureReport 6-67, 6-69,
6-72
AuthenticationRequest 6-85, 6-87, 6-92
AuthenticationStatusReport 6-98, 6-100,
6-104
BulkDeregistration 6-111
FeatureRequest 6-138
FlashRequest 6-140, 6-142
InformationDirective 6-168, 6-170
InformationForward 6-172
InterSystemAnswer 6-174
InterSystemPage 6-179
InterSystemPage2 6-185
InterSystemSetup 6-187
LocationRequest 6-195
MSInactive 6-197, 6-199, 6-200
OriginationRequest 6-205
QualificationDirective 6-207, 6-210
QualificationRequest 6-216, 6-218
RedirectionDirective 6-223
RedirectionRequest 6-225
RegistrationCancellation 6-229, 6-232
RegistrationNotification 6-241, 6-245
RoutingRequest 6-254, 6-261
SMSNotification 6-287
SMSRequest 6-292, 6-294, 6-296
TransferToNumberRequest 6-302
FC , : HLR analyze MS dialed number
FE
FEATREQ , 3-48
FeatReqPointOfReturn 6-130, 6-131, 6-132, 6-133,
6-134, 6-135,
FEATRESULT , 3-50, 3-52, 5-200

Feature Code 1-17	6-327, 6-328, 6-330, 6-331, 6-335, 6-336,	1
Feature Code GSL	6-337, 6-338, 6-339, 6-340, 6-341, 6-348,	2
Feature Request Response Timer 1-17,	6-349, 6-350, 6-352, 6-353, 6-354, 6-355,	3
FeatureActivity	6-362, 6-363, 6-364, 6-365, 6-366, 6-367,	4
CallingFeaturesIndicator 5-154	6-376, 6-377, 6-378, 6-379, 6-381, 6-382,	5
FeatureIdentifier 5-245	6-385, 6-390, 6-394, 6-395	6
FeatureInactive 5-21	FeatureRequest 6-128	7
FeatureRequest 1-17, 5-6, 5-24, 5-27, , 5-50,	Unsuccessful 6-308, 6-315, 6-316, 6-317, 6-	8
6-365, 6-369, 6-374, 6-380, 6-382, 6-383, 6-	318, 6-319, 6-320, 6-322, 6-323, 6-324, 6-	9
384, 6-389, 6-394, 6-395, 6-401	326, 6-327, 6-328, 6-330, 6-331, 6-336, 6-	10
operation components	337, 6-338, 6-339, 6-340, 6-341, 6-349, 6-	11
Invoke	350, 6-352, 6-353, 6-354, 6-355, 6-356, 6-	12
OTFI 3-251, 3-252, 3-266, 3-307, 3-	362, 6-363, 6-364, 6-365, 6-366, 6-367, 6-	13
344	375, 6-376, 6-377, 6-378, 6-379, 6-381, 6-	14
Return Result	382, 6-383, 6-384, 6-385, 6-386, 6-390, 6-	15
CCI 3-278, 3-282	391, 6-392, 6-393, 6-394, 6-395, 6-396	16
OTFI 3-251, 3-252, 3-267, 3-307, 3-	FeatureRequest 6-130, 6-135, 6-136, 6-	17
344, 3-345	137	18
PreferredLanguageIndicator 3-342	First Originating MarketID	19
operation definition 3-48-3-52, 5-48-5-51	PilotBillingID 5-231	20
operation usage	First Originating Switch Number	21
CC 3-278, 3-282, 3-284	PilotBillingID 5-231	22
CD 3-215	Flash	23
CFB 3-237	OneTimeFeatureIndicator 5-220	24
CFD 3-241	Flash Active	25
CFNA 3-245	OneTimeFeatureIndicator, Flash Privileges	26
CFU 3-247		27
CNIR 3-266	Flash Inactive	28
CW 3-250, 3-251, 3-252	OneTimeFeatureIndicator, Flash Privileges	29
DND 3-285		30
FA 3-287	Flash Privileges	31
general 3-203, 3-204, 3-205, 3-207, 3-	MSC analyze MS dialed number 6-15	32
211	OneTimeFeatureIndicator 5-221	33
MAH 3-315	Flash request	34
MWN 3-306, 3-307	SystemAccessType	35
PACA 3-344, 3-345, 3-346	Flash Request Timer 1-17	36
PCA 3-333	FLASHREQ , 3-53	37
PL 3-342	FlashRequest 1-17, 5-7, 5-25, 5-27, , 6-401	38
SCA 3-350	operation definition 3-53, 5-52	39
SPINA 3-356, 3-358, 3-360	operation usage	40
SPINI 3-362	general 3-206	41
VMR 3-370	FlashRequest procedures -	42
FeatureRequest procedures -	FlashRequest Timer	43
FeatureResult 1-17, 5-119,	Flexible Alerting 1-16, 5-195, 5-207, 5-309	44
FeatureRequest 6-137	Flexible Alerting (FA) procedures -	45
FeatureRequest RETURN RESULT 5-50	FMC	46
Success 6-340	SMS_OriginationRestrictions 5-282	47
Successful 6-308, 6-315, 6-316, 6-317, 6-318,	Force Indirect	48
6-319, 6-320, 6-322, 6-323, 6-324, 6-326,	SMS_OriginationRestrictions	49

1	Force Message Center	PreferredLanguageIndicator
2	SMS_OriginationRestrictions 5-282	Get SMS Address
3	Frame Offset	glare 4-20
4	CDMAChannelData 5-164	Global Service Logic 1-17,
5	French	Global Title Translation 1-17
6	PreferredLanguageIndicator	GrantedServiceInfo 2-12, 2-37
7	FRRT , 5-48, 6-127, 6-128, 6-129, , 6-	Set of parameters for Granted Service
8	405	Information. 2-23
9	FRT , 5-52, 6-138, 6-141,	GrantedTargetInfo 2-12, 2-23, 2-37
10	FU	Group 3 (G3) Fax messages
11	Full rate digital traffic channel acceptable	MessageWaitingNotificationCount
12	TDMACallMode	Group Not Reachable
13	Full rate digital traffic channel not acceptable	TerminationTriggers
14	TDMACallMode	GroupInformation 1-17, 5-126, , 6-345, 6-
15	Functional Entity 1-17,	347, 6-360
16	Functional Unit 1-17	FeatureRequest RETURN RESULT 5-50
17		LocationRequest RETURN RESULT 5-78
18		MS termination alerting 6-29, 6-31, 6-32
19		MSC route the call externally 6-38
20		OriginationRequest RETURN RESULT 5-82
21		RoutingRequest 6-257
22	G	TransferToNumberRequest INVOKE 5-110
23		TransferToNumberRequest RETURN RESULT
24	G reference point	5-111
25	Gateway MSC	GRPINFO , 3-52, 3-154, 3-155, 5-202
26	ExtendedMSCID, type	GSL
27	ExtendedSystemMyTypeCode	GSL Diagram Conventions
28	PC_SSN, Type	GTE 5-300
29	general background	GTT
30	GeneralInformation	
31	AnnouncementCode, Standard Announcement	
32		
33	GEOAUTH , 5-201	
34	GeographicAuthorization 1-17, 3-93, 3-100, 3-121,	
35	5-125,	H
36	Authorized for this cell only	
37	RegistrationNotification 6-236	H reference point
38	Authorized for this LocationAreaID within a	Half rate digital traffic channel acceptable
39	MarketID only	TDMACallMode
40	RegistrationNotification 6-236	Half rate digital traffic channel not acceptable
41	Authorized for this MarketID and Switch	TDMACallMode
42	Number only	HANDBACK , 2-3, 2-16, 2-17, 2-18, 2-46
43	RegistrationNotification 6-236	HANDBACK2 , 2-3, 2-20, 2-21, 2-23
44	Authorized for this MarketID only	HandBackParameterGroup 2-17
45	RegistrationNotification 6-236	HANDMREQ , 2-3, 2-25, 2-26, 2-44, 2-58, 2-
46	loading of profile parameters 6-10	60
47	Profile 5-234	HANDMREQ2 , 2-3, 2-27, 2-28, 2-29
48	QualificationDirective INVOKE 5-234	HandMReqParameters 2-26
49	QualificationRequest RETURN RESULT 5-234	handoff call task procedures 6-41-6-42
50	RegistrationNotification RETURN RESULT 5-	Handoff Call Tasks
51	234	Handoff Order Timer 1-17,
52	German	Handoff To Third Result Timer 1-17
53		
54		
55		
56		
57		
58		
59		
60		

Handoff To Third Timer 1-17	FacilitiesDirective 6-116, 6-119, 6-123	1
Handoff-Back task 2-17, 2-18, 2-20, 2-21, 2-23, 2-46	Terminator is handing off FacilitiesDirective 6-116, 6-119, 6-123	2
Handoff-Forward task 2-4, 2-5, 2-7, 2-9, 2-10, 2-12, 2-44, 2-50, 2-52, 2-58, 2-60	HandoffSuccessful ReleaseReason	3
Handoff-To-Third 6-401	HandoffToThird 1-17, 2-3, 2-30, 2-33, 2-34, 2-42, 2-52, 4-16, 4-19, 5-7, 5-25, 5-27, 5-62, 5-63, 5-179, 5-205, 6-401, 6-405	4
Handoff-To-Third Result Timer		5
Handoff-To-Third Timer		6
HandoffAbort Δcall over ReleaseReason	HandoffBack 6-148 operation definition 5-61-5-62	7
HandoffAbort Δnot received ReleaseReason	HandoffToThird procedures - HandoffToThird Second Chance 6-159	8
HandoffBack 1-17, 2-3, 2-16, 2-19, 2-20, 2-42, 4-16, 4-19, 5-7, 5-24, 5-27, 5-54, 5-179, 6-401	HandoffToThird2 1-17, 2-3, 2-34, 2-38, 2-42, 4-16, 4-19, 5-7, 5-25, 5-27, 5-65, 5-179, 5-205 HandoffBack 6-148 operation definition 5-63-5-65	9
FacilitiesDirective 6-119		10
HandoffBack 6-148		11
operation definition 5-53-5-54		12
HandoffBack procedures -	HandoffToThird2 procedures - HANDREASON , 5-203	13
HandoffBack2 1-17, 2-3, 2-20, 2-24, 2-42, 4-16, 4-19, 5-7, 5-25, 5-27, 5-57, 5-179	HANDTHIRD , 2-3, 2-30, 2-31, 2-32, 2-50, 2-52	14
HandoffBack 6-148		15
operation definition 5-55-5-57	HANDTHIRD2 , 2-3, 2-34, 2-35, 2-37	16
HandoffBack2 procedures -	HandThirdParameters 2-31	17
HandoffMeasurementRequest 1-17, 2-3, 2-25, 2-27, 2-42, 5-7, 5-24, 5-27, 5-59	High pitch AlertCode, pitch	18
operation definition 5-58	HLR 1-6, 1-24, ExtendedMSCID, type ExtendedSystemMyTypeCode	19
HandoffMeasurementRequest procedures -	PC_SSN, Type	20
HandoffMeasurementRequest2 1-17, 2-3, 2-27, 2-42, 5-7, 5-25, 5-27, 5-60	HLR Analyze MS Dialed Number OriginationRequest 6-202	21
operation definition 5-59-5-60	HLR CC Drop Last Party Invocation FeatureRequest 6-132	22
HandoffMeasurementRequest2 procedures -	HLR CC Invocation FeatureRequest 6-132	23
HandoffReason 1-17, 2-6, 2-17, 2-31, 5-120,	HLR CD Activation , 6-370 FeatureRequest 6-130	24
FacilitiesDirective INVOKE 5-42		25
FacilitiesDirective2 INVOKE 5-44	HLR CD De-Activation , 6-370 FeatureRequest 6-130	26
HandoffBack INVOKE 5-53		27
HandoffBack2 INVOKE 5-55	HLR CD Incoming Call Invocation , 6-345, 6-436, 6-440, 6-444, 6-446, 6-450, 6-454, 6-458	28
HandoffToThird INVOKE 5-61	LocationRequest 6-192	29
HandoffToThird2 INVOKE 5-63	HLR CFB Activation , 6-370	30
HandoffState 1-17, 2-6, 2-17, 5-126,	FeatureRequest 6-130	31
FacilitiesDirective 6-119, 6-123		32
FacilitiesDirective INVOKE 5-42	HLR CFB Busy MS Invocation 6-311, 6-440, 6-442, 6-444	33
FacilitiesDirective2 INVOKE 5-44	TransferToNumberRequest 6-298	34
HandoffBack INVOKE 5-53		35
HandoffBack2 INVOKE 5-55	HLR CFB De-Activation , 6-370	36
Originator is handing off	FeatureRequest 6-130	37
	HLR CFB De-Registration	38

1	FeatureRequest 6-130	TransferToNumberRequest 6-298
2	HLR CFB Registration	HLR CFNA Unroutable MS Invocation , 6-458,
3	FeatureRequest 6-130	6-460
4	HLR CFD Activation , 6-370	TransferToNumberRequest 6-299
5	FeatureRequest 6-131	HLR CFU Activation
6	HLR CFD Busy Call Invocation 6-440	FeatureRequest 6-131
7	HLR CFD Busy MS Invocation 6-311, , 6-444	HLR CFU Activation. 6-371
8	TransferToNumberRequest 6-298	HLR CFU De-Activation
9	HLR CFD De-Activation , 6-370	FeatureRequest 6-131
10	FeatureRequest 6-131	HLR CFU De-Activation. 6-371
11	HLR CFD De-Registration	HLR CFU De-Registration
12	FeatureRequest 6-131	FeatureRequest 6-131
13	HLR CFD Inactive MS Invocation 6-312, 6-313,	HLR CFU Incoming Call Invocation , 6-436
14	, 6-322, 6-446, 6-448	LocationRequest 6-191
15	HLR CFD Incoming Call Invocation , 6-436, 6-	HLR CFU Registration
16	442	FeatureRequest 6-131
17	LocationRequest 6-192	HLR CFU Unconditional MS Invocation
18	HLR CFD No Answer MS Invocation , 6-462	TransferToNumberRequest 6-300
19	TransferToNumberRequest 6-299	HLR CNIP Redirecting Call Invocation 6-312, 6-
20	HLR CFD Registration	314, 6-329,
21	FeatureRequest 6-130	LocationRequest 6-193
22	HLR CFD Unavailable MS Invocation 6-311, ,	OriginationRequest 6-203
23	6-450, 6-452	TransferToNumberRequest 6-300
24	HLR CFD Unresponsive MS Invocation 6-312,	HLR CNIP Terminating Call Invocation 6-309, 6-
25	, 6-454, 6-456	314,
26	TransferToNumberRequest 6-298	LocationRequest 6-193
27	HLR CFD Unroutable MS Invocation , 6-458,	OriginationRequest 6-203
28	6-460	RoutingRequest 6-250
29	TransferToNumberRequest 6-299	HLR CNIR Temporary Activation
30	HLR CFNA Activation , 6-370	FeatureRequest 6-132
31	FeatureRequest 6-131	HLR CNIR Temporary De-Activation
32	HLR CFNA De-Activation , 6-370	FeatureRequest 6-132
33	FeatureRequest 6-131	HLR CW Activation , 6-371
34	HLR CFNA De-Registration	FeatureRequest 6-132
35	FeatureRequest 6-131	HLR CW De-Activation , 6-371
36	HLR CFNA Inactive MS Invocation 6-312, 6-313,	FeatureRequest 6-132
37	, 6-326, 6-446, 6-448	HLR CW Temporary De-Activation
38	HLR CFNA Incoming Call Invocation	FeatureRequest 6-132
39	LocationRequest 6-192	HLR DND Activation , 6-371
40	HLR CFNA Incoming Call Invocation Task , 6-	FeatureRequest 6-132
41	436	HLR DND De-Activation , 6-371
42	HLR CFNA No Answer MS Invocation , 6-462	FeatureRequest 6-132
43	TransferToNumberRequest 6-299	HLR DND Incoming Call Invocation , 6-436
44	HLR CFNA Registration	LocationRequest 6-192
45	FeatureRequest 6-131	HLR FA Busy MS Invocation , 6-348, 6-442
46	HLR CFNA Unavailable MS Invocation 6-311,	TransferToNumberRequest 6-298
47	, 6-450, 6-452	HLR FA Inactive MS Invocation , 6-448
48	HLR CFNA Unresponsive MS Invocation 6-311,	HLR FA Incoming Call Invocation , 6-345, 6-
49	, 6-454, 6-456	430, 6-432

LocationRequest 6-191	HLR MAH Membership Activation , 6-372	1
HLR FA Membership Activation , 6-371	FeatureRequest 6-133	2
FeatureRequest 6-132	HLR MAH Membership De-Activation , 6-372	3
HLR FA Membership De-Activation , 6-371	FeatureRequest 6-133	4
FeatureRequest 6-133	HLR MAH No Answer MS Invocation , 6-462	5
HLR FA No Answer MS Invocation , 6-462	TransferToNumberRequest 6-299	6
TransferToNumberRequest 6-299	HLR MAH Revertive Call Invocation	7
HLR FA Revertive Call Invocation	HLR analyze MS dialed number 6-19	8
HLR analyze MS dialed number 6-19	LocationRequest 6-191	9
LocationRequest 6-191	HLR MAH Unavailable MS Invocation , 6-452	10
HLR FA Unavailable MS Invocation , 6-452	HLR MAH Unresponsive MS Invocation , 6-	11
HLR FA Unresponsive MS Invocation , 6-456	456	12
TransferToNumberRequest 6-298	TransferToNumberRequest 6-298	13
HLR FA Unroutable MS Invocation , 6-460	HLR MAH Unroutable MS Invocation , 6-460	14
TransferToNumberRequest 6-299	TransferToNumberRequest 6-299	15
HLR Initiating a Information Directive 6-426	HLR MWN Demand Alert Pip Tone Activation	16
HLR Initiating a Qualification Directive , 6-	, 6-372	17
350, 6-351, 6-426	FeatureRequest 6-133	18
FeatureRequest 6-136	HLR MWN Demand Alert Pip Tone De-Activation	19
HLR Initiating a Remote User Interaction Directive	, 6-372	20
, 6-365, 6-369, 6-380, 6-381, 6-382, 6-383,	FeatureRequest 6-133	21
6-384, 6-385, 6-386, 6-388, 6-389, 6-390, 6-	HLR MWN Demand Pip Tone Activation , 6-	22
392	371	23
HLR Initiating a Routing Request , 6-310, 6-	FeatureRequest 6-133	24
343, 6-357, 6-394, 6-397	HLR MWN Demand Pip Tone De-Activation ,	25
OriginationRequest 6-203	6-372	26
HLR Initiating a Unreliable Roamer Data Directive	FeatureRequest 6-133	27
	HLR MWN Demand Pip Tone Temporary De-	28
HLR Initiating an Information Directive , 6-	Activation	29
329	FeatureRequest 6-133	30
HLR Initiating Registration Cancellation	HLR MWN Pip Tone Temporary De-Activation	31
RegistrationNotification 6-241		32
HLR Initiating SMSNotification INVOKE	HLR MWN Status Change Invocation	33
RegistrationNotification 6-243	HLR PACA Per Call Invocation	34
HLR Initiation of Information Directive 6-436	FeatureRequest 6-134	35
HLR Initiation of Remote User Interaction	HLR PCA Activation , 6-372	36
Directive 6-432, 6-434, 6-436, 6-438	FeatureRequest 6-134	37
HLR Initiation of Routing Request 6-432, 6-434, 6-	HLR PCA De-Activation , 6-373	38
436, 6-440, 6-442, 6-444, 6-446, 6-448, 6-450, 6-	FeatureRequest 6-134	39
452, 6-454, 6-456, 6-458, 6-460, 6-462	HLR PCA Diversion Number De-Registration	40
HLR MAH Busy MS Invocation , 6-361, 6-442	FeatureRequest 6-134	41
TransferToNumberRequest 6-298	HLR PCA Diversion Number Registration	42
HLR MAH Demand Ordering	FeatureRequest 6-133	43
HLR MAH Demand Ordering Registration 6-372	HLR PCA Incoming Call Invocation , 6-436	44
FeatureRequest 6-133	LocationRequest 6-191	45
HLR MAH Inactive MS Invocation , 6-448	HLR PCA Password De-Registration , 6-372	46
HLR MAH Incoming Call Invocation , 6-359,	FeatureRequest 6-134	47
6-430, 6-434	HLR PCA Password Registration , 6-372	48
LocationRequest 6-191	FeatureRequest 6-134	49

1	HLR PL Language Registration , 6-373	Point of Return 6-317, 6-320, 6-321, 6-325, 6-
2	FeatureRequest 6-134	329, 6-366, 6-379, 6-380,
3	HLR Receiving a FeatureRequest INVOKE 6-426	HLR SPINA Activation 6-373,
4	HLR Receiving a LocationRequest INVOKE 6-430,	FeatureRequest 6-135
5	6-436, 6-438	HLR SPINA De-Activation 6-373,
6	HLR Receiving an OriginationRequest INVOKE	FeatureRequest 6-135
7		HLR SPINA Registration 6-373,
8		FeatureRequest 6-135
9	HLR Receiving an SMSRequest INVOKE	HLR SPINI Feature Request Invocation 6-315, 6-
10	HLR Receiving AuthenticationDirective INVOKE	318, 6-322, 6-326, 6-362, 6-375, , 6-398
11		HLR SPINI Originating Call Invocation
12	HLR Receiving AuthenticationFailureReport	HLR SPINI Originating Call Invocation Task
13	INVOKE	OriginationRequest 6-202
14	HLR Receiving AuthenticationRequest INVOKE	HLR SPINI Registration 6-374,
15		FeatureRequest 6-135
16	HLR Receiving AuthenticationStatusReport	HLR VMR Invocation , 6-396
17	INVOKE	FeatureRequest 6-135
18	HLR Receiving BaseStationChallenge INVOKE	HLR VMR Revertive Call Invocation
19		HLR analyze MS dialed number 6-19
20		LocationRequest 6-191
21	HLR Receiving BulkDeregistration INVOKE	HLR VMR Voice Mailbox PIN Registration
22	HLR Receiving CountRequest INVOKE	FeatureRequest 6-135
23	HLR Receiving FeatureRequest INVOKE	HLR VMR VoiceMailboxPIN Registration 6-374,
24	HLR Receiving LocationRequest INVOKE	
25	HLR Receiving MSInactive INVOKE	HLRID
26	HLR Receiving QualificationRequest INVOKE	HLRINFO
27	HLR Receiving RegistrationNotification INVOKE	HLRInformation 1-17
28		hold
29	HLR Receiving Transfer-to-Number Request 6-442	commanded disconnect 6-39
30	6-448, 6-452, 6-456, 6-460, 6-462	in call MS flash attempt 6-14
31	HLR Receiving TransferToNumberRequest INVOKE	other party disconnect 6-39
32		Home Location Register , 1-17, 1-24,
33		Home Location Register Identification 1-17
34		Home MSC
35	HLR RFC Incoming Call Invocation , 6-438	ExtendedMSCID, type
36	HLR SCA Activation 6-373,	ExtendedSystemMyTypeCode
37	FeatureRequest 6-135	PC_SSN, Type
38	HLR SCA De-Activation 6-373,	Home System
39	FeatureRequest 6-135	HOSTATE , 5-204
40	HLR SCA Diversion Number De-Registration	HOT , 2-3, 5-42, 5-44, 5-53, 5-55, 6-118, 6-
41	FeatureRequest 6-134	120, 6-144, 6-145, 6-164, 6-165, , 6-405
42	HLR SCA Diversion Number Registration	Hours
43	FeatureRequest 6-134	AuthorizationPeriod
44	HLR SCA Incoming Call Invocation , 6-436	DeniedAuthorizationPeriod
45	LocationRequest 6-191	HTTTRT , 6-157, , 6-405
46	HLR SCA Number De-Registration 6-373,	HTTT , 2-3, 5-61, 5-63, 6-156, 6-157, ,
47	FeatureRequest 6-135	6-405
48	HLR SCA Number Registration 6-373,	
49	FeatureRequest 6-134	
50	HLR Select Forward-To or Diversion Number	
51	Courtesy Call Point of Return 6-315, 6-316, 6-	
52	318, 6-319, 6-322, 6-323, 6-326, 6-328,	
53	HLR Select Forward-To or Diversion Number	
54		
55		
56		
57		
58		
59		
60		

IA5		Priority CW	
DigitsType, Encoding		RoutingRequest 6-256	1
IAM		RoutingRequest 6-256	2
ID Number		Incoming FA Call Attempt GSL	3
BillingID 5-150		Incoming MAH Call Attempt GSL	4
PilotBillingID 5-231		Incoming MDN Call Attempt GSL	5
Idle		Incoming MS Call Attempt 6-430	6
TrunkStatus		Incoming MS Call Attempt GSL	7
Idle Mobile Origination 6-422, 6-424		Incoming RFC Call Attempt GSL	8
Idle MS Origination		IncomingAdditionalCallTone	9
IDT , 5-66, 6-166, 6-167,		AnnouncementCode, Tone	10
IFT , 5-68, 6-170, 6-171,		Incorrect Parameter 5-21, 5-23	11
Ignore		IncorrectParameter 5-333	12
OneTimeFeatureIndicator, CNIR		IncorrectParameter) 5-333	13
OneTimeFeatureIndicator, CWFI		Indefinite	14
OneTimeFeatureIndicator, Flash Privileges		AuthorizationPeriod	15
OneTimeFeatureIndicator, MWN		INET 5-300	16
OneTimeFeatureIndicator, PACA		INFODIR , 3-55	17
Ignore OneTimeFeatureIndicator, CWIC		INFOFWD , 3-57	18
ILATA		Information Directive Timer 1-17,	19
OriginationTriggers		Information Forward Timer 1-17,	20
SPINITriggers		InformationDirective 1-17, 5-7, 5-25, 5-27, ,	21
IMPLICIT		5-67, 6-401	22
IMSCCID , 2-39, 2-40, 3-18, 3-54, 3-58, 3-59,		operation components	23
3-71, 3-137, 3-141, 3-411, 3-413, 5-204		Invoke	24
In Call Flash Attempt 6-424		CallingPartyNumberString1 3-264	25
In Call MS Flash Attempt		CallingPartyNumberString2 3-264	26
In-Call Flash Attempt GSL		CallingPartySubaddress 3-264	27
Inability to Release in Response to a		RedirectingNumberString 3-264	28
FacilitiesRelease INVOKE 4-24		RedirectingSubaddress 3-264	29
InaccessibleSubscriber		operation definition 3-55-3-56, 5-66-5-67	30
AnnouncementCode, Standard Announcement		operation usage	31
Inactive		CFU 3-249, 3-269	32
AccessDeniedReason		CNIP 3-264	33
DMH_RedirectionIndicator		InformationDirective procedures -	34
Inactive MS Detected GSL		InformationForward 1-17, 5-7, 5-25, 5-27, , 6-	35
Inactive Re-Routing GSL		401	36
Incoming Call Attempt , 6-428		operation components	37
Incoming Call Attempt GSL		Invoke	38
incoming call waiting type		CallingPartyNumberString1 3-262	39
No CW		CallingPartyNumberString2 3-262	40
RoutingRequest 6-256		CallingPartySubaddress 3-262	41
Normal CW		RedirectingNumberString 3-262	42
RoutingRequest 6-256		RedirectingSubaddress 3-262	43
		operation definition 3-57-3-58, 5-68-5-69	44
		operation usage	45
		CNIP 3-262	46
		InformationForward procedures -	47
		Initial Address Message 1-17	48
			49
			50
			51
			52
			53
			54
			55
			56
			57
			58
			59
			60

1	InitialInterdigitTime	InterSystemAnswer 6-174
2	DigitCollectionControl 5-186	InterSystemAnswer INVOKE 5-70
3	Initialize the OneTimeFeatureIndicator Parameter	InterSystemSetup 6-185, 6-187
4		InterSystemSetup INVOKE 5-76
5	idle MS origination 6-13	ResetCircuit INVOKE 5-98
6	RoutingRequest 6-251	SMSDeliveryBackward 6-261, 6-263
7	Initiating MSC Initiating a Facilities Release	SMSDeliveryBackward INVOKE 5-102
8	InterSystemAnswer 6-173, 6-174	SMSDeliveryForward 6-264, 6-267
9	Initiating SMS Delivery Point-To-Point	SMSDeliveryForward INVOKE 5-104
10	SMSDeliveryPointToPoint 6-268, 6-277, 6-280,	TrunkTest INVOKE 5-113
11	6-282	TrunkTestDisconnect INVOKE 5-114
12	Int11	Unblocking INVOKE 5-115
13	OriginationTriggers	InterMSCCircuitIdentification 1-17
14	SPINITriggers	internal trunk group
15	Integer 5-327,	MSC route the call externally 6-35
16	Integrated Services Digital Network 1-18, 1-24,	InternalOfficeFailure
17		AnnouncementCode, Standard Announcement
18	InterceptTone	
19	AnnouncementCode, Tone	International
20	interdigit timer 6-400	DigitsType, Nature of Number
21	RemoteUserInteractionDirective 6-246, 6-247,	OriginationTriggers
22	6-248	SPINITriggers
23	INTERFACE REFERENCE POINTS	International Alphabet 5 1-17
24	Interference	International calls
25	SignalQuality	OriginationIndicator
26	INTERMSC TRUNK TESTING 4-25	International Standards Organization 1-18
27	InterMSCCircuitID 2-5, 2-14, 2-17, 2-31, 4-4, 4-5,	International Telegraph and Telephone
28	4-6, 4-7, 4-8, 5-119, 6-417	Consultative Committee 1-15
29	AuthenticationDirectiveForward 6-60, 6-61	Internet Protocol 1-17
30	AuthenticationDirectiveForward INVOKE 5-31	Internet Protocol (IP) Address
31	Blocking INVOKE 5-39	DigitsType, Numbering Plan
32	FacilitiesDirective 6-122	InterofficeLinkFailure
33	FacilitiesDirective (path minimization) 6-164	AnnouncementCode, Standard Announcement
34	FacilitiesDirective INVOKE 5-42	
35	FacilitiesDirective2 INVOKE 5-44	InterSwitchCount 1-18, 2-5, 2-31, 2-52, 5-119,
36	FacilitiesRelease 6-127	
37	FacilitiesRelease INVOKE 5-47	FacilitiesDirective 6-115, 6-117, 6-120, 6-122
38	FlashRequest 6-138, 6-140, 6-141, 6-142	FacilitiesDirective (path minimization) 6-164
39	FlashRequest INVOKE 5-52	FacilitiesDirective INVOKE 5-42
40	HandoffBack 6-144, 6-147	FacilitiesDirective2 INVOKE 5-44
41	HandoffBack INVOKE 5-53	HandoffToThird 6-159, 6-160, 6-163
42	HandoffBack2 INVOKE 5-55	InterSystemSetup 6-186, 6-187
43	HandoffToThird 6-156, 6-159, 6-160, 6-161,	InterSwitchCount (Serving)
44	6-163	HandoffToThird 6-156
45	HandoffToThird INVOKE 5-61	HandoffToThird INVOKE 5-61
46	HandoffToThird2 INVOKE 5-63	HandoffToThird2 INVOKE 5-63
47	InformationDirective 6-168	InterSystem 5-72
48	InformationForward 6-170, 6-171, 6-172	Intersystem Answer Response Timer
49	InformationForward INVOKE 5-68	Intersystem Answer Timer
50		
51		
52		
53		
54		
55		
56		
57		
58		
59		
60		

Intersystem Handoff	OriginationTriggers	1
Intersystem Page Notification	SPINITriggers	2
InterSystemPage 6-175, 6-176	Invalid	3
Intersystem Page Request Timer	RoutingRequest 6-254, 6-261	4
intersystem page response notification	SMS_AccessDeniedReason	5
page an MS 6-27	Invalid ESN	6
intersystem procedures 6-42-6-307	SMSNotification 6-287	7
intersystem services	SMSRequest 6-291, 6-294, 6-295	8
Intersystem Setup Timer	Invalid serial number	9
Intersystem Setup Wait Timer	AuthorizationDenied, Reason	10
InterSystemAnswer 1-17, 1-18, 2-3, 5-7, 5-25, 5-	Invalid Teleservice ID	11
27, , 6-402	SMS_CauseCode	12
operation definition 2-39, 3-59, 5-70	InvalidAccessCode	13
InterSystemAnswer procedures -	AnnouncementCode, Standard Announcement	14
InterSystemAnswer Response Timer 1-18		15
InterSystemAnswer Timer 1-18	InvalidESN	16
InterSystemPage 1-18, 5-7, 5-25, 5-27, , 5-73,	AnnouncementCode, Standard Announcement	17
6-402		18
operation definition 3-60-3-64, 5-71-5-73	InvalidForwardToNumber	19
operation usage	AnnouncementCode, Standard Announcement	20
CD 3-224		21
RoutingRequest 6-255	InvalidModifierDigits	22
InterSystemPage procedures -	AnnouncementCode, Standard Announcement	23
InterSystemPage2 1-18, 5-7, 5-25, 5-27, , 5-		24
75, 6-402	InvalidPrefix	25
operation definition 3-65-3-69, 5-74-5-75	AnnouncementCode, Standard Announcement	26
InterSystemPage2 procedures -		27
InterSystemSetup 1-18, 4-10, 4-11, 4-12, 4-13,	INVOKE 5-23	28
4-17, 4-19, 4-20, 4-22, 4-23, 5-7, 5-25, 5-27,	IP	29
, 5-205, 6-402	IP Address 5-324	30
InterSystemPage2 6-183	IS-136	31
operation definition 3-70-3-72, 5-76	TerminalType	32
InterSystemSetup procedures -	IS-41-C 6-405	33
InterSystemSetup Request Timer 1-18	IS-54-B	34
InterSystemSetup Wait Timer 1-18	TerminalType	35
IntersystemTermination 1-18, 5-111, 5-122,	IS-88	36
6-310, 6-313, 6-314, 6-343, 6-344, 6-345, 6-	TerminalType	37
357, 6-358, 6-395, 6-397, 6-422, 6-424, 6-428, 6-	IS-91	38
430, 6-432, 6-434, 6-436, 6-440, 6-442, 6-444, 6-	TerminalType	39
446, 6-448, 6-450, 6-452, 6-454, 6-456, 6-460, 6-	IS-94	40
462	TerminalType	41
LocationRequest 6-193	IS-95	42
MSC route the call externally 6-35, 6-36, 6-37	TerminalType	43
MSC Routing Points of Return 6-21	IS-95-A	44
originating call sent 6-22	TerminalType	45
OriginationRequest 6-203	IS-95-A. 5-307	46
TerminationList 5-309	ISANSWER , , 2-3, 2-39, 2-40, 3-59	47
TransferToNumberRequest 6-300	ISART , 6-173,	48
Intra-LATA Toll	ISAT , 2-3, 5-70, 6-173,	49

1	ISCOUNT	, 5-205	LocalTermination	5-208
2	ISDN	, 1-24,	MS termination alerting	6-29, 6-31, 6-32
3	ISDN Numbering		MSC ActionCode Processing	6-24
4	DigitsType, Numbering Plan		MSC route the call externally	6-35, 6-36, 6-37,
5	ISDN User Part	1-18	6-38, 6-39	
6	ISO		originating call sent	6-23
7	ISPAGE	, 3-60	RedirectionRequest	INVOKE 5-91
8	ISPAGE2	, 3-65	RoutingRequest	6-257
9	ISPRT	, 5-72, 5-74, 6-175, 6-176, 6-180, 6-	RoutingRequest	INVOKE 5-99
10	181,		TransferToNumberRequest	INVOKE 5-110
11	ISSETUP	, 3-70	UnsolicitedResponse	RETURN RESULT 5-118
12	ISSRT	, 5-76, 6-185, 6-186,	wait for TLDN call	6-26
13	ISSUES FOR FURTHER STUDY	4-28	LG Information and Communications	5-300
14	ISSWT	, 6-183,	Listen only	
15	ISTERM	, 5-206	PageIndicator	
16	ISUP		LMMRT	, 2-3, 5-58, 5-59, 6-149, 6-152,
17	ISUP Charge Number		Loading of Profile Parameters	, 6-237
18	MSC route the call externally	6-35	QualificationDirective	6-205, 6-208
19	ITU 1989, ITU 1988		QualificationRequest	6-213, 6-216
20			RegistrationNotification	6-242
21			Local	
22			OriginationTriggers	
23			SPINITriggers	
24			Local Access and Transport Area	1-18
25			Local calls only	
26			OriginationIndicator	
27			Local Recovery Procedures	6-9, 6-13, , 6-173,
28			6-463	
29			AuthenticationDirective	6-44, 6-45, 6-49, 6-
30			50, 6-53	
31			AuthenticationDirectiveForward	6-58, 6-61
32			AuthenticationFailureReport	6-62, 6-63, 6-65,
33			6-67, 6-72, 6-74, 6-75	
34			AuthenticationRequest	6-77, 6-78, 6-81, 6-83,
35			6-84, 6-85, 6-86	
36			AuthenticationStatusReport	6-93, 6-96, 6-97,
37			6-99, 6-102	
38			authorize MS termination attempt	6-28
39			BaseStationChallenge	6-104, 6-105, 6-107
40	Land Mobile Numbering		BulkDeregistration	6-110
41	DigitsType, Numbering Plan		CountRequest	6-112, 6-113
42	Land-to-Mobile Directory Number access	5-308	FacilitiesDirective	6-119, 6-120, 6-123
43	TerminationAccessType		FacilitiesDirective (path minimization)	6-165
44	last calling party	6-376, 6-377, 6-378	FacilitiesRelease	6-124, 6-125, 6-126
45	LATA		FeatureRequest	6-128, 6-129
46	DigitsType, Type of Digits		FlashRequest	6-138, 6-139, 6-141
47	Latitude		HandoffBack	6-145, 6-148
48	MSLocation	5-216	HandoffMeasurementRequest	6-149
49	LB	, 4-15	HandoffMeasurementRequest2	6-152
50	Least Significant Bit	1-18		
51	LEGINFO	, 3-110, 3-131, 3-154, 5-207		
52	LegInformation	1-18, 5-125, , 5-236, 6-347,		
53	6-360			
54	InterSystemPage	INVOKE 5-72		
55	IntersystemTermination	5-206		
56				
57				
58				
59				
60				

HandoffToThird 6-157	120,		1
in call MS flash attempt 6-14	AuthenticationDirective 6-48		2
InformationDirective 6-166, 6-167	AuthenticationDirective INVOKE 5-29		3
InformationForward 6-170	AuthenticationRequest 6-78		4
InterSystemAnswer 6-173, 6-174	GeographicAuthorization 5-201		5
InterSystemPage 6-176, 6-178	InterSystemPage 6-175, 6-177		6
InterSystemPage2 6-180, 6-181, 6-183	InterSystemPage INVOKE 5-72		7
InterSystemSetup 6-185, 6-186	InterSystemPage2 6-180, 6-182		8
LocationRequest 6-190	InterSystemPage2 INVOKE 5-74		9
MSC Routing Points of Return 6-21, 6-22	MSInactive 6-195, 6-197, 6-199		10
MSInactive 6-195, 6-196, 6-197, 6-198	MSInactive INVOKE 5-80		11
OriginationRequest 6-202	page an MS 6-27		12
QualificationDirective 6-205, 6-206, 6-208	QualificationDirective INVOKE 5-84		13
QualificationRequest 6-211, 6-212, 6-214	QualificationRequest 6-212		14
RandomVariableRequest 6-218, 6-219	RegistrationNotification 6-235, 6-236		15
RedirectionDirective 6-221, 6-222	RegistrationNotification INVOKE 5-94		16
RedirectionRequest 6-223, 6-224	RoutingRequest 6-251		17
RegistrationCancellation 6-226, 6-227, 6-228,	RoutingRequest INVOKE 5-99		18
6-230	LocationRequest 1-18, 5-7, 5-24, 5-27,	5-78,	19
RegistrationNotification 6-234, 6-239	5-110, 5-310, 6-310, 6-313, 6-402		20
RoutingRequest 6-250, 6-251, 6-252	operation components		21
SMSDeliveryPointToPoint 6-269, 6-280, 6-281,	Invoke		22
6-282	CallingPartyNumberDigits1 3-258, 3-		23
SMSNotification 6-285, 6-286	260, 3-261, 3-264, 3-265, 3-351		24
SMSRequest 6-289, 6-290, 6-292, 6-293	CallingPartyNumberDigits2 3-258, 3-		25
TransferToNumberRequest 6-297	260, 3-261, 3-264, 3-265, 3-351		26
UnreliableRoamerDataDirective 6-302, 6-303	CallingPartySubaddress 3-258, 3-260,		27
UnsolicitedResponse 6-305	3-261, 3-264, 3-265		28
wait for TLDN call 6-27	RedirectingNumberDigits 3-258, 3-		29
local SPINI operation 5-235	260, 3-261, 3-264, 3-265, 3-351		30
loading of profile parameters 6-12	RedirectingSubaddress 3-258, 3-260,		31
Locally and Remotely Blocked 1-18,	3-261, 3-264, 3-265		32
4-11, 4-12, 4-21, 4-22, 4-23	Return Result		33
Locally Blocked 1-18,	ANNCODE 3-352		34
4-11, 4-12, 4-21, 4-22,	HLRLegNumber 3-331		35
4-23	NoAnswerTime 3-290, 3-294, 3-296,		36
LocalTermination 1-18, 5-78, 5-82, 5-111, 5-122,	3-304, 3-317		37
6-310, 6-314, 6-342, 6-345, 6-356, 6-357,	RedirectingNumberDigits 3-269, 3-		38
6-394, 6-397, 6-422, 6-424, 6-428, 6-430, 6-432,	274		39
6-434, 6-436, 6-440, 6-442, 6-444, 6-446, 6-448,	RedirectingSubaddress 3-269, 3-274		40
6-450, 6-452, 6-454, 6-456, 6-458, 6-460, 6-462	operation definition 3-73-3-81, 5-77-5-79		41
LocationRequest 6-192, 6-193	operation usage		42
MSC Routing Points of Return 6-20	CD 3-216, 3-218, 3-219, 3-220, 3-221, 3-		43
OriginationRequest 6-202, 6-203	224, 3-227, 3-239, 3-274, 3-276		44
TerminationList 5-309	CFB 3-238		45
TransferToNumberRequest 6-300	CFD 3-241, 3-242, 3-244		46
Location Measurement Maximum Response Timer	CFNA 3-245, 3-246, 3-271		47
1-18,	CFU 3-249		48
Location Request Timer 1-18,	CNIP 3-255, 3-258, 3-260, 3-261, 3-264,		49
LocationAreaID 1-18, 3-61, 3-66, 3-119, 3-131, 5-			50

1	3-265	RoutingRequest 3-318, 3-319, 3-323
2	CNIR 3-269, 3-274	TransferToNumberRequest 3-317, 3-326
3	CW 3-253	MAHO ,
4	DND 3-285, 3-286	MAHT , , 6-405
5	FA 3-289, 3-292, 3-296, 3-303	maintenance
6	MAH 3-317, 3-321, 3-323, 3-330	SMS_TeleserviceIdentifier 5-284
7	PCA 3-335, 3-337, 3-338, 3-339, 3-340	Mandatory for Backward Compatibility 1-18
8	RFC 3-349	ManufacturerIs Code
9	SCA 3-351, 3-352, 3-353, 3-354	ElectronicSerialNumber 5-196
10	LocationRequest procedures -	MAP
11	LOCID , 3-8, 3-10, 3-12, 3-13, 3-15, 3-83, 3-	Maritime Mobile Numbering
12	84, 3-91, 3-96, 5-209	DigitsType, Numbering Plan
13	LOCREQ , 3-73	Market Identification
14	LocReqPointOfReturn 6-191, 6-192	MarketID ,
15	LocationRequest 6-191	BillingID 5-150
16	LOCTERM , 5-208	ExtendedMSCID 5-197
17	Long	GeographicAuthorization 5-201
18	AlertCode, Cadence	MSCID 5-214
19	long and ugly	PilotBillingID 5-231
20	GeographicAuthorization 5-201	SystemAccessData 5-295
21	Long Code Mask	MAT , 6-122, 6-123, 6-148, , 6-405
22	CDMAChannelData 5-164	MAXHANDOFF , 5-205
23	Longitude	FacilitiesDirective 6-115, 6-120, 6-122
24	MSLocation 5-216	InterSystemSetup 6-187
25	loop-back 5-113, 5-114, 5-250	maximum interaction timer 6-400
26	SeizureType	RemoteUserInteractionDirective 6-246, 6-247, 6-248
27	Loss of Messages in the Release Sequence 4-24	Maximum Number of Conferees
28	Low pitch	ConferenceCallingIndicator 5-178
29	AlertCode, pitch	MaximumCollect
30	Lower	DigitCollectionControl 5-186
31	NAMPSChannelData	MaximumHandoffCount 1-18
32	LRB , , 4-15	MaximumInteractionTime
33	LRT , 5-77, 6-189, 6-190,	DigitCollectionControl 5-186
34	LSB	MBC
35	Lucent Technologies 5-300	MC , 1-24,
36		MC Initiating SMS Delivery Point-To-Point to an MS-Based SME
37		SMSDeliveryPointToPoint 6-280
38		SMSNotification 6-286
39		MC Initiating SMS Request
40		SMSDeliveryPointToPoint 6-281
41		MC Receiving an SMSDeliveryPointToPoint INVOKE
42		MC Receiving an SMSNotification INVOKE
43		MCI 5-300
44		MDN , 3-66, 5-212
45		MeasurementInfo 2-29
46		Medium pitch
47	M reference point	
48	MA	
49	MAH , , (see Mobile Access Hunting), 6-402	
50	DMH_RedirectionIndicator	
51	FeatureRequest 3-315	
52	LocationRequest 3-317, 3-321, 3-323, 3-330	
53	OriginationRequest 3-329	
54	QualificationDirective 3-315	
55	RedirectionRequest 3-325	
56		
57		
58		
59		
60		

M

AlertCode, pitch	3-84, 3-85, 3-87, 3-90, 3-95, 3-96, 3-98, 3-107,	1
Member Not Reachable	3-110, 3-113, 3-119, 3-131, 3-137, 3-141, 3-	2
TerminationTriggers	144, 3-148, 3-150, 3-154, 3-159, 3-406, 3-411,	3
Member Number	3-413, 5-213	4
PC_SSN 5-230	MIN or ESN authorization failure	5
Message Center 1-18, 1-24,	DenyAccess, Reason	6
Message Handling Systems 1-18	MIN/ESN mismatch	7
Message Transfer Part 1-19	ReportType	8
Message Waiting Indication	MIN/HLRMismatch 5-20	9
MessageWaitingNotificationType	MIN1	10
Message Waiting Notification 1-19, 5-235	MIN2	11
count 5-210	MinimumCollect	12
options 5-211	DigitCollectionControl 5-186	13
Message Waiting Notification (MWN) procedures	Minutes	14
-	DeniedAuthorizationPeriod	15
MessageWaitingNotification	Missing authentication parameters	16
OneTimeFeatureIndicator 5-221	AuthorizationDenied, Reason	17
MessageWaitingNotificationCount 1-19, 3-58, 3-93,	DenyAccess, Reason	18
3-100, 3-121, 5-122, , 6-351, 6-352	ReportType	19
InformationForward 6-171	Missing expected parameter	20
InformationForward INVOKE 5-68	SMS_CauseCode	21
loading of profile parameters 6-11	missing mandatory parameter 5-21	22
Profile 5-234	SMS_CauseCode	23
QualificationDirective INVOKE 5-234	MissingParameter 5-21, 5-199, 5-333	24
QualificationRequest RETURN RESULT 5-234	Mobile Access Hunt Timer 1-18,	25
RegistrationNotification RETURN RESULT 5-	Mobile Access Hunting 1-18, 5-195	26
234	Mobile Access Hunting (MAH) procedures -	27
MessageWaitingNotificationType 1-19, 3-58, 3-93,		28
3-100, 3-121, 5-125, , 6-351, 6-352	Mobile Application 1-18	29
InformationForward 6-171	Mobile Application Part 1-18	30
InformationForward INVOKE 5-68	Mobile Arrival Timer 1-18,	31
loading of profile parameters 6-11	Mobile Assisted Handoff , 1-18	32
Message Waiting Indication 5-235	Mobile Handoff Order Timer 1-18,	33
Pip Tones	Mobile Identification Number 1-18	34
initialize OTFI 6-24	Mobile Station , 1-18, 1-24,	35
Profile 5-234	Mobile Switching Center , 1-18, 1-24,	36
QualificationDirective INVOKE 5-234	Mobile Switching Center Identification 1-18	37
QualificationRequest RETURN RESULT 5-234	Mobile Switching CenterΔGateway 1-18	38
RegistrationNotification RETURN RESULT 5-	Mobile Switching CenterΔHome 1-18	39
234	Mobile Switching CenterΔVisited 1-18	40
MHOT , 6-118, 6-119, 6-145, 6-165, , 6-	Mobile-to-Mobile Directory Number access	41
405	TerminationAccessType	42
MHS	MobileDirectory 3-62	43
Middle	MobileDirectory-Number 3-52	44
NAMPSChannelData	MobileDirectoryNumber 1-18, 3-50, 3-75, 3-81, 3-	45
MIN , 2-5, 2-14, 2-17, 2-31, 2-39, 2-40, 3-8,	87, 3-88, 3-93, 3-100, 3-121, 3-132, 3-155, 3-	46
3-10, 3-12, 3-13, 3-15, 3-16, 3-18, 3-20, 3-23,	156, 3-160, 5-122, 5-192, 5-193, , 6-309,	47
3-32, 3-38, 3-40, 3-42, 3-50, 3-52, 3-54, 3-56,	6-333, 6-335	48
3-58, 3-59, 3-61, 3-66, 3-71, 3-75, 3-81, 3-83,	FeatureRequest INVOKE 5-48	49

1	FeatureRequest RETURN RESULT 5-50	FacilitiesDirective2 INVOKE 5-44
2	InterSystemPage INVOKE 5-72	FacilitiesRelease 6-127
3	InterSystemPage2 INVOKE 5-74	FacilitiesRelease INVOKE 5-47
4	IntersystemTermination 5-206	FeatureRequest 6-127, 6-137
5	loading of profile parameters 6-11	FeatureRequest INVOKE 5-48
6	LocalTermination 5-208	FlashRequest 6-138, 6-140, 6-142
7	LocationRequest 6-194	FlashRequest INVOKE 5-52
8	LocationRequest RETURN RESULT 5-78	HandoffBack 6-144, 6-147
9	MS termination alerting 6-30, 6-32	HandoffBack INVOKE 5-53
10	MSC route the call externally 6-35	HandoffBack2 INVOKE 5-55
11	OriginationRequest 6-204	HandoffMeasurementRequest 6-151
12	OriginationRequest INVOKE 5-81	HandoffMeasurementRequest2 6-154
13	OriginationRequest RETURN RESULT 5-82	HandoffToThird 6-156, 6-160, 6-161, 6-163
14	Profile 5-234	HandoffToThird INVOKE 5-61
15	QualificationDirective INVOKE 5-234	HandoffToThird2 INVOKE 5-63
16	QualificationRequest RETURN RESULT 5-234	InformationDirective 6-166, 6-168, 6-169, 6-
17	RegistrationNotification RETURN RESULT 5-	170
18	234	InformationDirective INVOKE 5-66
19	RoutingRequest 6-250, 6-257	InformationForward 6-170, 6-171, 6-172
20	RoutingRequest INVOKE 5-99	InformationForward INVOKE 5-68
21	TransferToNumberRequest RETURN RESULT	InterSystemAnswer 6-174
22	5-111	InterSystemAnswer INVOKE 5-70
23	UnsolicitedResponse RETURN RESULT 5-118	InterSystemPage 6-175, 6-179
24	MobileIdentificationNumber 5-100, 5-102, 5-104,	InterSystemPage INVOKE 5-72
25	5-106, 5-119, 5-192, 5-193, , 5-236, 5-320,	InterSystemPage2 6-184
26	6-309, 6-310, 6-342, 6-356, 6-391, 6-394, 6-	InterSystemPage2 INVOKE 5-74
27	395, 6-411, 6-412, 6-414	InterSystemSetup 6-185, 6-187
28	AuthenticationDirective 6-42, 6-46, 6-50, 6-	InterSystemSetup INVOKE 5-76
29	51, 6-52	IntersystemTermination 5-206
30	AuthenticationDirective INVOKE 5-29	LocalTermination 5-208
31	AuthenticationDirectiveForward 6-58, 6-60	LocationRequest 6-190
32	AuthenticationDirectiveForward INVOKE 5-31	LocationRequest RETURN RESULT 5-78
33	AuthenticationFailureReport 6-66, 6-68, 6-69,	MS termination alerting 6-30, 6-32
34	6-71, 6-72	MSC record the DMH parameters 6-34
35	AuthenticationFailureReport INVOKE 5-32	MSC route the call externally 6-35, 6-36, 6-37
36	AuthenticationRequest 6-78, 6-84, 6-85, 6-86,	MSInactive 6-195, 6-196, 6-197, 6-198, 6-199,
37	6-87, 6-91, 6-92	6-200
38	AuthenticationRequest INVOKE 5-34	MSInactive INVOKE 5-80
39	AuthenticationStatusReport 6-97, 6-98, 6-99,	OriginationRequest 6-201, 6-205
40	6-100, 6-103	OriginationRequest INVOKE 5-81
41	AuthenticationStatusReport INVOKE 5-36	QualificationDirective 6-205, 6-207, 6-208, 6-
42	BaseStationChallenge 6-104, 6-106, 6-108, 6-	210
43	109	QualificationDirective INVOKE 5-84
44	BaseStationChallenge INVOKE 5-38	QualificationRequest 6-210, 6-215, 6-217
45	CountRequest 6-111, 6-114, 6-115	QualificationRequest INVOKE 5-86
46	CountRequest INVOKE 5-41	RedirectionDirective 6-221, 6-222, 6-223
47	FacilitiesDirective 6-118, 6-122	RedirectionDirective INVOKE 5-89
48	FacilitiesDirective (path minimization) 6-164	RedirectionRequest 6-224, 6-225
49	FacilitiesDirective INVOKE 5-42	RedirectionRequest INVOKE 5-91
50		
51		
52		
53		
54		
55		
56		
57		
58		
59		
60		

RegistrationCancellation 6-226, 6-229, 6-232	MS-Based SME Receiving an SMD-REQUEST	1
RegistrationCancellation INVOKE 5-92		2
RegistrationNotification 6-233, 6-240, 6-244	MS-Based SME Receiving an Unexpected SMD-ACK or SMD-NAK	3
RegistrationNotification INVOKE 5-94		4
RoutingRequest 6-250, 6-253, 6-254, 6-257, 6-258, 6-260, 6-261	MSB	5
RoutingRequest INVOKE 5-99	MSC , , 1-24,	6
SMSDeliveryBackward 6-263	MSC ActionCode Processing	7
SMSDeliveryBackward INVOKE 5-102	FeatureRequest 6-128	8
SMSDeliveryForward 6-264, 6-266	OriginationRequest 6-201	9
SMSDeliveryForward INVOKE 5-104	TransferToNumberRequest 6-297	10
SMSDeliveryPointToPoint 6-267, 6-268, 6-269	MSC Analyze Mobile Dialed Number 6-422, 6-424	11
6-271, 6-273, 6-274, 6-277, 6-278, 6-282	MSC Analyze MS Dialed Number	12
SMSDeliveryPointToPoint INVOKE 5-106	FeatureRequest 6-128	13
SMSNotification 6-285, 6-286, 6-287	idle MS origination 6-13	14
SMSNotification INVOKE 5-108	in call MS flash attempt 6-15	15
SMSRequest 6-288, 6-291, 6-292, 6-293, 6-294, 6-295, 6-296	MSC Awaiting InterSystemAnswer	16
SMSRequest INVOKE 5-109	FacilitiesDirective 6-119, 6-123	17
TransferToNumberRequest 6-296, 6-301, 6-302	FacilitiesRelease 6-125	18
TransferToNumberRequest INVOKE 5-110	InterSystemSetup 6-186	19
UnsolicitedResponse 6-307	MSC capable of Remote User Interaction 1-21	20
UnsolicitedResponse INVOKE 5-117	MSC CC Invocation	21
MobileOnChannel 1-19, 2-3, 2-4, 2-9, 5-7, 5-24, 5-26, 5-27,	FeatureRequest 6-128	22
FacilitiesDirective 6-118, 6-123	MSC CNIP Call Origination Invocation 6-422	23
FacilitiesDirective (path minimization) 6-165	MSC CNIP Originating Call Invocation	24
operation definition 5-79	MSC route the call externally 6-36	25
MobileReorder	MSC CNIP Redirecting Call Invocation	26
AnnouncementCode, Tone	MSC route the call externally 6-36	27
MobileSerialNumber 5-196	MSC CNIP Terminating Call Invocation 6-331,	28
MOB_P_REV 5-167, 5-307	MS termination alerting 6-30	29
Most Significant Bit 1-18	MSC CNIR Originating Call Invocation 6-334,	30
Motorola 5-300	MSC CNIR Redirecting Call Invocation	31
MS , , 1-24,	MSC CW Processing for Flash Request	32
MS Disconnect	MSC CW Terminating Call Invocation	33
MS Inactive Timer 1-19,	MS termination alerting 6-32	34
MS presence confirmation procedure	MSC Detecting an Unsolicited Page Response	35
InterSystemPage 6-177		36
InterSystemPage2 6-183	InterSystemPage 6-177	37
UnsolicitedResponse 6-304	InterSystemPage2 6-182	38
MS Termination	MSC Detecting Feature Request , 6-422, 6-424, 6-426	39
TerminationTreatment	MSC analyze MS dialed number 6-16	40
MS Termination Alerting	MSC Initiating a Base Station Challenge	41
authorize MS termination attempt 6-29	MSC receiving authentication parameters 6-54	42
MS-Based SME Initiating SMD-REQUEST toward an MSC	MSC Initiating a Facilities Release	43
SMSDeliveryPointToPoint 6-268	FacilitiesRelease 6-126	44
	MSC Initiating a FacilitiesDirective for Path Minimization	45
	HandoffToThird 6-159, 6-162	46
		47
		48
		49
		50
		51
		52
		53
		54
		55
		56
		57
		58
		59
		60

1	MSC Initiating a FacilitiesRelease	MSC Initiating an InterSystemPage
2	HandoffBack 6-148	page an MS 6-27
3	MSC Initiating a Location Request	MSC Initiating an InterSystemPage2
4	incoming call attempt 6-25, 6-26	page an MS 6-27
5	MSC analyze MS dialed number 6-18	MSC Initiating an MS Inactive
6	MSC Initiating a Qualification Request	registration call tasks 6-9
7	authorize MS termination attempt 6-29	MSC Initiating an Origination Request
8	InterSystemPage 6-177	MSC analyze MS dialed number 6-15, 6-16, 6-
9	MSC analyze MS dialed number 6-18	17
10	RoutingRequest 6-254	MSC Initiating InterSystemAnswer
11	UnsolicitedResponse 6-304	FacilitiesDirective 6-119, 6-123
12	MSC Initiating a Random Variable Request	FacilitiesRelease 6-125
13	MSC Initiating a Redirection Directive	MSC Initiating MS Registration , 6-422
14	MSC Initiating a Redirection Request	authorize MS termination attempt 6-29
15	MS termination alerting 6-29, 6-31, 6-33	idle MS origination 6-13
16	wait for TLDN call 6-26	InterSystemPage 6-178
17	MSC Initiating a Security Status Report	registration call tasks 6-9
18	InterSystemPage2 6-181	UnsolicitedResponse 6-305
19	MSC Initiating a Transfer-To-Number Request	MSC Initiating Qualification Request
20	MS termination alerting 6-29, 6-30, 6-31, 6-32	idle MS origination 6-13
21	6-33	MSC Initiating SMD-REQUEST toward an MS-
22	MSC route the call externally 6-38, 6-39	Based SME
23	originating call sent 6-23	SMSDeliveryForward 6-266
24	RedirectionRequest 6-223, 6-224	SMSDeliveryPointToPoint 6-268, 6-274
25	wait for TLDN call 6-26	MSC Initiating SMS Delivery Backward , 6-
26	MSC Initiating an Authentication Directive Forward	417
27	MSC receiving authentication parameters 6-54	SMSDeliveryBackward 6-263
28	MSC Initiating an Authentication Failure Report	MSC Initiating SMS Delivery Forward
29	MSC Initiating an Authentication Request	SMSDeliveryPointToPoint 6-268
30	authorize MS termination attempt 6-28	MSC Initiating SMS Notification
31	idle MS origination 6-13	MSC Initiating SMSDeliveryForward
32	in call MS flash attempt 6-14	SMSDeliveryForward 6-267
33	InterSystemPage 6-178	SMSDeliveryPointToPoint 6-275
34	registration call tasks 6-9	MSC Initiation of a Authentication Failure Report
35	UnsolicitedResponse 6-305	AuthenticationRequest 6-76
36	MSC Initiating an Authentication Status Report	MSC Initiation of an Intersystem Setup
37	InterSystemPage2 6-182	MS termination alerting 6-29
38	MSC receiving authentication parameters 6-53,	MSC Initiation of an Origination Request 6-424
39	6-54, 6-55, 6-56, 6-57	MSC Initiation of Facilities Release
40	MSC Initiating an AuthenticationRequest	FacilitiesDirective 6-119, 6-120, 6-123
41	FlashRequest 6-139	FacilitiesDirective (path minimization) 6-165
42	MSC Initiating an Information Forward , 6-	MSC Initiation of FacilitiesRelease
43	331, 6-352	HandoffBack 6-145
44	InformationDirective 6-169	HandoffToThird 6-157
45	MSC Initiating an Intersystem Setup	MSC Initiation of Facility Directive for Path
46	InterSystemPage2 6-182	Minimization
47		FacilitiesRelease 6-125
48		MSC Initiation of Location Request 6-428, 6-430,
49		6-432, 6-434, 6-436, 6-438, 6-440, 6-444, 6-446,
50		
51		
52		
53		
54		
55		
56		
57		
58		
59		
60		

6-450, 6-454, 6-458			
MSC Initiation of Origination Request 6-422	MSC Receiving RedirectionDirective INVOKE		1
MSC Initiation of Qualification Request 6-422			2
MSC Initiation of Random Variable Request	MSC Receiving RedirectionRequest INVOKE		3
AuthenticationRequest 6-76	MSC Receiving RegistrationCancellation INVOKE		4
MSC Initiation of Redirection Request 6-442, 6-448,			5
6-452, 6-456, 6-460, 6-462	MSC Receiving RoutingRequest INVOKE		6
MSC Initiation of Transfer-to-Number Request 6-	MSC Receiving UnsolicitedResponse INVOKE		7
442, 6-448, 6-452, 6-456, 6-460, 6-462			8
MSC MWN Call Origination Invocation , 6-422	MSC Record the DMH Parameters		9
idle MS origination 6-13	MSC route the call externally 6-35		10
MSC MWN Call Termination Invocation	RoutingRequest 6-257		11
MSC MWN Status Change Invocation	MSC Remote User Interaction , 6-422, 6-424		12
InformationForward 6-171	FeatureRequest 6-128		13
QualificationDirective 6-209	LocationRequest 6-190		14
QualificationRequest 6-211	OriginationRequest 6-202		15
RegistrationNotification 6-234	TransferToNumberRequest 6-297		16
MSC PACA Call Origination Invocation , 6-	MSC Route the Call Leg Externally		17
422	LocationRequest 6-189		18
idle MS origination 6-13	MSC Routing Points of Return 6-22		19
MSC Receiving a InformationForward INVOKE	TransferToNumberRequest 6-297		20
	MSC Routing Points Of Return , 6-422, 6-424,		21
MSC Receiving a User Interaction Digit	6-428, 6-430, 6-432, 6-434, 6-436, 6-440, 6-442,		22
RemoteUserInteractionDirective 6-246, 6-247	6-444, 6-446, 6-448, 6-450, 6-452, 6-454, 6-456,		23
MSC Receiving an InformationDirective INVOKE	6-458, 6-460, 6-462		24
	FeatureRequest 6-128		25
MSC Receiving an SMSDeliveryBackward INVOKE	idle MS origination 6-13		26
	LocationRequest 6-189		27
MSC Receiving an SMSDeliveryForward INVOKE	MSC analyze MS dialed number 6-19		28
	OriginationRequest 6-201		29
MSC Receiving an SMSDeliveryPointToPoint	TransferToNumberRequest 6-297		30
INVOKE	MSC Special MS Alerting , 6-331		31
MSC Receiving an SMSRequest INVOKE	InformationDirective 6-168		32
MSC Receiving an Unexpected SMD-ACK or	InformationForward 6-171		33
SMD-NAK	MSC SPINI Originating Call Invocation , 6-422		34
MSC Receiving Authentication Parameters	MSC analyze MS dialed number 6-18		35
AuthenticationDirective 6-51	MSC-G ,		36
AuthenticationFailureReport 6-62	MSC-H ,		37
AuthenticationRequest 6-77	MSC-V ,		38
AuthenticationStatusReport 6-93	MSCID , 2-31, 3-20, 3-23, 3-32, 3-61, 3-74,		39
MSC Receiving AuthenticationDirective INVOKE	3-75, 3-81, 3-87, 3-98, 3-101, 3-105, 3-119, 3-		40
	123, 3-131, 3-132, 3-134, 3-157, 5-32, 5-119,		41
MSC Receiving FacilitiesRelease INVOKE	5-150, 5-197, , 5-231, 5-295, 6-313, 6-314,		42
MSC Receiving InterSystemPage	6-394, 6-395		43
MSC Receiving InterSystemSetup INVOKE	(HLR)		44
InterSystemPage2 6-183	UnreliableRoamerDataDirective 6-304		45
MSC Receiving QualificationDirective INVOKE	(Originating)		46
	LocationRequest 6-188		47
MSC Receiving RandomVariableRequest INVOKE	(Serving)		48
			49
			50
			51
			52
			53
			54
			55
			56
			57
			58
			59
			60

1	MSC Routing Points of Return 6-20	313, 6-395
2	(Target)	FeatureRequest INVOKE 5-48
3	FacilitiesDirective (path minimization) 6-	InterSystemPage INVOKE 5-72
4	164	InterSystemPage RETURN RESULT 5-73
5	HandoffBack 6-147	IntersystemTermination 5-206
6	HandoffToThird 6-156, 6-160, 6-163	LocationRequest 6-188
7	AuthenticationFailureReport 6-62, 6-69, 6-72	LocationRequest INVOKE 5-77
8	AuthenticationRequest 6-76, 6-78	MSC route the call externally 6-35, 6-36
9	FeatureRequest 6-127	OriginationRequest INVOKE 5-81
10	InterSystemPage 6-175, 6-178	RedirectionDirective 6-221
11	LocationRequest 6-190, 6-192, 6-193	RedirectionDirective INVOKE 5-89
12	MSC (Border)	RedirectionRequest INVOKE 5-91
13	page an MS 6-28	RoutingRequest 6-250, 6-259
14	MSC route the call externally 6-35, 6-36	RoutingRequest INVOKE 5-99
15	OriginationRequest 6-201, 6-202	RoutingRequest RETURN RESULT 5-101
16	QualificationRequest 6-210, 6-211, 6-212	TransferToNumberRequest 6-296
17	RandomVariableRequest 6-218	TransferToNumberRequest INVOKE 5-110
18	RegistrationNotification 6-233, 6-235, 6-236,	MSCIdentificationNumber (Origination MSC)
19	6-237	UnsolicitedResponse RETURN RESULT 5-118
20	RoutingRequest 6-250, 6-252, 6-254, 6-255,	MSCIN , 3-61, 3-154, 5-215
21	6-256, 6-257, 6-259	MSINACT , 3-82, 3-399, 3-403, 3-404
22	UnreliableRoamerDataDirective 6-302	MSInactive 1-19, 5-7, 5-24, 5-27, , 6-402
23	UnsolicitedResponse 6-304, 6-305, 6-306	operation definition 3-82-3-85, 5-80
24	MSCID (HLR)	RegistrationCancellation 6-226
25	QualificationRequest RETURN RESULT 5-87	MSInactive procedures -
26	RegistrationNotification RETURN RESULT 5-	MSIT , 5-80,
27	96	MSLOC , 5-216
28	UnreliableRoamerDataDirective INVOKE 5-116	MSLocation 1-19, 2-11, 2-21, 2-28, 2-35, 5-121,
29	MSCID (Originating MSC)	FacilitiesDirective 6-117
30	InterSystemPage INVOKE 5-72	FacilitiesDirective2 INVOKE 5-44
31	OriginationRequest INVOKE 5-81	HandoffBack 6-144
32	RoutingRequest INVOKE 5-99	HandoffBack2 INVOKE 5-55
33	MSCID (Originating) 5-78, 5-110	HandoffMeasurementRequest2 6-152
34	LocationRequest INVOKE 5-77	HandoffMeasurementRequest2 INVOKE 5-59
35	MSCID (Serving MSC or Originating MSC)	HandoffToThird 6-156
36	QualificationRequest INVOKE 5-86	HandoffToThird2 INVOKE 5-63
37	MSCID (Serving MSC) 5-209	MSONCH , 2-3, 2-7, 2-12, 2-44, 2-50, 2-52,
38	AuthenticationRequest INVOKE 5-34	2-58, 2-60
39	LocationRequest RETURN RESULT 5-78	MSTermination
40	RandomVariableRequest INVOKE 5-88	MSC Routing Points of Return 6-20
41	RegistrationNotification INVOKE 5-94	MTP
42	MSCID (Serving)	Multiple access
43	FeatureRequest INVOKE 5-48	AuthorizationDenied, Reason
44	IntersystemTermination 5-206	Multiple Termination 6-345
45	RoutingRequest RETURN RESULT 5-101	Multiple Terminations
46	MSCID (Target)	TransactionCapability
47	HandoffToThird INVOKE 5-61	MultipleAccess
48	HandoffToThird2 INVOKE 5-63	CancellationDenied
49	MSCIdentificationNumber 1-19, 5-122, , 6-	
50		
51		
52		
53		
54		
55		
56		
57		
58		
59		
60		

MultipleTermination 6-310, 6-313, 6-314, 6-394, 6-395	NAMPSChannelData 1-19, 2-11, 2-12, 2-21, 2-23, 2-28, 2-35, 2-37, 5-122, 5-176,	1
LocationRequest 6-193	FacilitiesDirective 6-117, 6-118, 6-120, 6-121	2
OriginationRequest 6-203	FacilitiesDirective (path minimization) 6-164, 6-165	3
TransferToNumberRequest 6-300		4
MWI Off	HandoffBack 6-144, 6-145, 6-147	5
MessageWaitingNotificationType	HandoffMeasurementRequest2 6-151, 6-152	6
MWI On	HandoffToThird 6-156, 6-157, 6-158, 6-161	7
MessageWaitingNotificationType	HandoffToThird2 6-160, 6-163	8
MWN , , (see Message Waiting Notification)	NAMPSChannelData (Serving)	9
FeatureRequest 3-306, 3-307	FacilitiesDirective2 INVOKE 5-44	10
OneTimeFeatureIndicator 5-220	HandoffBack2 INVOKE 5-55	11
QualificationDirective 3-306, 3-309, 3-310, 3-313, 3-314	HandoffMeasurementRequest2 INVOKE 5-59	12
QualificationRequest 3-313, 3-314	HandoffToThird2 INVOKE 5-63	13
MWN Alert Pip Tone Notification 6-350	NAMPSChannelData (Target)	14
MWN MS Indication 6-350, 6-351	FacilitiesDirective2 RETURN RESULT 5-46	15
MWN Pip Tone Notification 6-350, 6-351	HandoffBack2 RETURN RESULT 5-57	16
MWNCOUNT , 5-210	HandoffToThird2 RETURN RESULT 5-65	17
MWNTYPE , 5-211	NAMPSMODE , 5-217	18
MYTYP , 3-90, 3-91, 3-95, 3-96, 3-98, 3-101, 3-103, 3-120, 3-123, 3-125, 3-154, 5-299	NANP , 5-190, 5-222, 5-248	19
	Narrow AMPS 1-19	20
	Narrow Analog Voice Channel Assignment (NAVCA)	21
	NAMPSChannelData 5-218	22
	NATIME , 5-219	23
	National	24
	DigitsType, Nature of Number	25
	National long distance	26
	OriginationIndicator	27
	NCHDATA , 5-218	28
	NEC 5-300	29
	Negative Acknowledgment Signal 1-19	30
	network entity relationship	31
	Network failure	32
	SMS_CauseCode	33
	Network Number	34
	PC_SSN 5-230	35
	Network provided	36
	DigitsType, Nature of Number	37
	Network Reference Model	38
	Network resource shortage	39
	SMS_CauseCode	40
	Network Service Access Point 1-19	41
	NewNet 5-300	42
	No access	43
	SystemAccessType	44
	No acknowledgment 5-264	45
	SMS_CauseCode	46
	No Answer 5-219, 5-314	47
		48
		49
		50
		51
		52
		53
		54
		55
		56
		57
		58
		59
		60

N

N reference point

N-ISDN

N11

 HLR analyze MS dialed number 6-19

 MSC analyze MS dialed number 6-15

NACK

NAMPS ,

NAMPS channel acceptable

 CDMACallMode

 NAMPSCallMode

NAMPS channel not acceptable

 CDMACallMode

 NAMPSCallMode

NAMPSCallMode 1-19, 2-11, 2-21, 2-28, 2-35, 5-126,

 FacilitiesDirective 6-117

 FacilitiesDirective2 INVOKE 5-44

 HandoffBack 6-144, 6-145

 HandoffBack2 INVOKE 5-55

 HandoffMeasurementRequest2 INVOKE 5-59

 HandoffToThird 6-156

 HandoffToThird2 INVOKE 5-63

1	RedirectionReason	MSC route the call externally 6-37
2	No Answer Call	OriginationRequest RETURN RESULT 5-82
3	TerminationTriggers	RoutingRequest INVOKE 5-99
4	No Answer Call Re-Routing GSL	TransferToNumberRequest RETURN RESULT
5	No Answer Leg	5-111
6	TerminationTriggers	NoAnswerTrigger
7	No Answer Time 5-79, 5-83, 5-219, 6-405	originating call sent 6-22
8	no answer timer 6-400	NoBreak
9	MS termination alerting 6-30, 6-31	DigitCollectionControl
10	MSC route the call externally 6-37, 6-38	NoCircuit
11	originating call sent 6-22, 6-23	AnnouncementCode, Standard Announcement
12	No Answer Trigger	node specific teleservices
13	TerminationTriggers	SMS_TeleserviceIdentifier 5-284
14	No authentication required	NoLECN
15	AuthenticationCapability	None
16	No charge 5-267	AnnouncementCode, Standard Announcement
17	SMS_ChargeIndicator	
18	No CW	None Reachable
19	OneTimeFeatureIndicator, CWFI	TerminationTriggers
20	OneTimeFeatureIndicator, CWIC	NoPageResponse
21	No digits	AlertResult
22	OriginationTriggers	AnnouncementCode, Standard Announcement
23	SPINTriggers	
24	No information	Normal CW 5-220
25	QualificationInformationCode	OneTimeFeatureIndicator, CWFI
26	No messages are waiting	OneTimeFeatureIndicator, CWIC
27	MessageWaitingNotificationCount	NormalInterdigitTime
28	No more pending SMS messages	DigitCollectionControl 5-186
29	SMS_MessageCount	NORTEL 5-300
30	No MWI	North American Numbering Plan 1-19
31	MessageWaitingNotificationType	NOSSD , 3-16, 3-24, 3-27, 3-28, 3-32, 3-39,
32	No Page Response 5-264	5-292
33	AccessDeniedReason	Not a usable signal
34	RedirectionReason	SignalQuality
35	SMS_CauseCode	not attempted
36	TerminationTriggers	AuthenticationDirectiveForward 6-58, 6-59
37	No Page Response Call	Not authorized
38	TerminationTriggers	CallingFeaturesIndicator
39	No Page Response Leg	Not Authorized for the MSC
40	TerminationTriggers	AuthorizationDenied, Reason
41	No Page Response Trigger	Not distinguished
42	TerminationTriggers	TerminalType
43	NoAnswer	Not specified
44	AnnouncementCode, Standard Announcement	AlertResult
45	NoAnswerTime 1-19, 5-123, , 6-309, 6-345	DMH_RedirectionIndicator
46	FeatureRequest RETURN RESULT 5-50	ExtendedMSCID, type 5-197
47	LocationRequest RETURN RESULT 5-78	ExtendedSystemMyTypeCode, type 5-198
48	MS termination alerting 6-30	Not used 5-161
49		
50		
51		
52		
53		
54		
55		
56		
57		
58		
59		
60		

AccessDeniedReason 5-128	TransferToNumberRequest 6-301	1
ActionCode	UniqueChallengeReport 5-318	2
AuthenticationCapability 5-143	UnsolicitedResponse 6-307	3
AuthenticationDirective 6-46, 6-50, 6-52	UpdateCount 5-319	4
AuthenticationFailureReport 6-66, 6-68, 6-71	Not valid 4-14	5
AuthenticationRequest 6-84, 6-86, 6-92	NotAttempted	6
AuthenticationStatusReport 6-97, 6-99, 6-103	AlertResult	7
AuthorizationDenied, Reason 5-147	Notify when available 5-271	8
AvailabilityType 5-149	SMS_NotificationIndicator	9
BorderCellAccess 5-151	NoTone	10
CallingFeaturesIndicator 5-154	AlertCode, Cadence	11
CancellationDenied 5-160	NoTypeAhead	12
ConditionallyDeniedReason 5-177	DigitCollectionControl	13
CountUpdateReport 5-181	NovAtel 5-300	14
DeniedAuthorizationPeriod 5-182	NoWinkReceived	15
DenyAccess, Reason 5-183	AnnouncementCode, Standard Announcement	16
DeregistrationType 5-184		17
FeatureRequest 6-137	NPA	18
FeatureResult 5-200	NPA-NXX 5-222	19
GeographicAuthorization 5-201	NPA-NXX-XXXX 5-222	20
HandoffReason 5-203	NPA of MIN 1-18	21
InterSystemPage 6-179	NPA-NXX-XXXX 1-23	22
InterSystemPage2 6-184	NPR	23
LocationRequest 6-194	NSAP	24
OriginationIndicator 5-222	Subaddress, Type	25
OriginationRequest 6-204	NULL	26
PageIndicator 5-229	Number is available	27
QualificationDirective 6-207, 6-210	DigitsType, Nature of Number	28
QualificationInformationCode 5-237	Number is not available	29
QualificationRequest 6-215, 6-217	DigitsType, Nature of Number	30
RedirectionDirective 6-222	Number of calls	31
RedirectionReason 5-245	AuthorizationPeriod	32
RedirectionRequest 6-225	DeniedAuthorizationPeriod	33
RegistrationNotification 6-240, 6-244	Number of Messages Waiting	34
ReportType 5-247	MessageWaitingNotificationCount 5-210	35
RoutingRequest 6-253, 6-260	Numbering Plan Area 1-19	36
SetupResult 5-252	NXX	37
SMSNotification 6-287	NXX-XXXX of MIN 1-18	38
SMSRequest 6-291, 6-293, 6-295		39
SMS_AccessDeniedReason 5-256		40
SMS_ChargeIndicator 5-267		41
SMS_NotificationIndicator 5-271		42
SSDNotShared 5-292		43
SSDUpdateReport 5-293		44
SystemAccessType 5-296		45
SystemMyTypeCode 5-300		46
TerminalType		47
TerminationRestrictionCode 5-310		48
TerminationTreatment 5-311		49
		50
		51
		52
		53
		54
		55
		56
		57
		58
		59
		60

O

1	Signaling Message Encryption	MessageWaitingNotification 6-351
2	Voice Privacy	MSC disconnect 6-39
3	Off-loading	No CW 6-330
4	HandoffReason	Normal CW
5	OffHookTone	RoutingRequest 6-256
6	AnnouncementCode, Tone	OneTimeFeatureIndicator Call Waiting For
7	Office Code 1-19	Future Incoming Calls
8	OLATA	MS termination alerting 6-31
9	OriginationTriggers	OriginationRequest INVOKE 5-81
10	OMT	OriginationRequest RETURN RESULT 5-82
11	On	other party disconnect 6-39
12	Signaling Message Encryption	Priority Access and Channel Assignment
13	Voice Privacy	initialize OTFI 6-24
14	OneTimeFeatureIndicator 1-19, 5-48, 5-123,	Priority Access and Channel Assignment
15	6-256, 6-309, 6-310, 6-335, 6-336, 6-341, 6-	(PACA) 6-367
16	345, 6-356, 6-367	Priority Call Waiting for future incoming calls
17	Call Waiting	initialize OTFI 6-23
18	RoutingRequest 6-256	MS termination alerting 6-31
19	Call Waiting for future incoming calls	Priority CW
20	initialize OTFI 6-23	RoutingRequest 6-256
21	MS termination alerting 6-31	RoutingRequest 6-250, 6-251, 6-255, 6-256,
22	Call Waiting for the existing call	6-259
23	MS termination alerting 6-31	RoutingRequest INVOKE 5-99
24	Calling Number Identification Restriction 6-	UnsolicitedResponse RETURN RESULT 5-118
25	335, 6-336	OPC
26	initialize OTFI 6-24	OPDU
27	commanded disconnect 6-40	Open Systems Interconnection 1-19
28	FeatureRequest 6-127, 6-128, 6-130	Operation Protocol Data Unit 1-19
29	FeatureRequest INVOKE 5-48	operation timer values 6-400-6-405
30	FeatureRequest RETURN RESULT 5-50	Operational Measurements. 4-28
31	Flash Privileges	OperationNotSupported 5-20
32	MSC analyze MS dialed number 6-15	Operations, Administration, and Maintenance 1-19
33	FlashPrivileges	OperationSequenceProblem 5-20
34	in call MS flash attempt 6-14	OriginalDestinationAddress 6-411
35	future incoming calls	OriginalDestinationSubaddress 6-411
36	Ignore 6-332	OriginalOriginatingAddress 6-411
37	No CW 6-331	OriginalOriginatingSubaddress 6-411
38	Normal CW 6-331	Originating Call Sent
39	Priority CW 6-331	originating call task procedures 6-12-6-25
40	incoming call Call Waiting	Originating MarketID
41	Normal CW 6-331	BillingID 5-150
42	Priority CW 6-331	Originating MC Supplementary Services
43	initialize OTFI 6-23	SMSDeliveryPointToPoint 6-278
44	InterSystemPage INVOKE 5-72	Originating MSC
45	LocalTermination 5-208	ExtendedMSCID, type
46	LocationRequest 6-189	ExtendedSystemMyTypeCode
47	LocationRequest RETURN RESULT 5-78	PC_SSN, Type
48	Message Waiting Notification 6-349	Originating Point Code 1-19
49	initialize OTFI 6-24	Originating SMS supplementary service , 1-19
50		
51		
52		
53		
54		
55		
56		
57		
58		
59		
60		

originating supplementary services 6-267, 6-278, 6-279	MSC analyze MS dialed number 6-17	1
Originating Switch Number	DP	2
BillingID 5-150	MSC analyze MS dialed number 6-16	3
OriginatingAddress 6-412	DS	4
OriginatingSubaddress 6-412	MSC analyze MS dialed number 6-15	5
Origination Call Tasks 6-12	ILATA	6
Origination denied	MSC analyze MS dialed number 6-17	7
OriginationIndicator	Int11	8
Origination Request Timer 1-19,	MSC analyze MS dialed number 6-17	9
OriginationDenied	loading of profile parameters 6-11	10
AnnouncementCode, Standard Announcement	Local	11
	MSC analyze MS dialed number 6-17	12
OriginationIndicator 1-19, 3-92, 3-100, 3-120, 5-119, 5-190, , 5-248	MSC analyze MS dialed number 6-15, 6-17	13
loading of profile parameters 6-11	OLATA	14
Origination denied	MSC analyze MS dialed number 6-17	15
MSC analyze MS dialed number 6-18	OriginationRequest 6-201	16
OriginationRequest 6-204	OriginationRequest INVOKE 5-81	17
Prior agreement	Pound	18
QualificationDirective 6-207, 6-210	MSC analyze MS dialed number 6-16	19
Profile 5-234	Profile 5-234	20
QualificationDirective 6-207, 6-210	QualificationDirective INVOKE 5-234	21
QualificationDirective INVOKE 5-234	QualificationRequest RETURN RESULT 5-234	22
QualificationRequest 6-215, 6-217	RegistrationNotification RETURN RESULT 5-234	23
QualificationRequest RETURN RESULT 5-234	Revertive Call	24
RegistrationNotification RETURN RESULT 5-234	MSC analyze MS dialed number 6-17	25
Selected NPA-NXX	Star	26
QualificationDirective 6-207, 6-210	MSC analyze MS dialed number 6-16	27
QualificationRequest 6-215, 6-217	Unrec	28
OriginationRequest 1-19, 5-7, 5-25, 5-27, , 5-82, 5-223, 5-224, 5-225, 5-226, 5-227, 5-235, 6-374, 6-386, 6-388, 6-394, 6-395, 6-403	WZ	29
operation components	MSC analyze MS dialed number 6-17	30
Return Result	Originator is handing off	31
HLRLegNumber 3-329	HandoffState	32
operation definition 3-86-3-88, 5-81-5-83	ORIGIND , 5-222	33
operation usage	ORIGTRIG , 3-87, 5-223	34
FA 3-301	ORREQ , 3-86	35
MAH 3-329	OrReqMultTerm 6-202, 6-203	36
SPINI 3-364, 3-365, 3-366	ORT , 5-81,	37
VMR 3-371	OSI	38
OriginationRequest procedures -	OSSS ,	39
OriginationTriggers 1-19, 3-93, 3-100, 3-121, 5-123,	OTFI , 3-50, 3-52, 3-131, 5-220	40
All	Other Actions on Receipt of a Blocking INVOKE 4-13	41
MSC analyze MS dialed number 6-15	Other DQPSK channel acceptable	42
Count	TDMACallMode	43
	Other DQPSK channel not acceptable	44
	TDMACallMode	45
	Other Failure Conditions 4-24	46
		47
		48
		49
		50
		51
		52
		53
		54
		55
		56
		57
		58
		59
		60

1	Other general problems 5-266	PACAIND , 3-52, 5-228
2	SMS_CauseCode.	PACAIndicator 1-19, 3-93, 3-100, 3-121, 5-125,
3	Other network problem 5-263	, 6-367
4	SMS_CauseCode	FeatureRequest RETURN RESULT 5-50
5	Other Party Disconnect	loading of profile parameters 6-11
6	Other radio interface problem 5-265	PACA Level 6-367
7	SMS_CauseCode	Permanent Activation (PA) 6-367
8	Other terminal problem 5-264	initialize OTFI 6-24
9	SMS_CauseCode	Profile 5-234
10	Other terminal problems 5-264	QualificationDirective INVOKE 5-234
11	Other values reserved	QualificationRequest RETURN RESULT 5-234
12	AlertCode, Alert Action 5-130	RegistrationNotification RETURN RESULT 5-
13	Other voice coding acceptable	234
14	TDMACallMode	Page
15	Other voice coding not acceptable.	PageIndicator
16	TDMACallMode	Page an MS Procedure
17	OtherDialingIrregularity	authorize MS termination attempt 6-28
18	AnnouncementCode, Standard Announcement	InterSystemPage 6-175, 6-176
19		MS termination alerting 6-29
20	OtherFacDirParameters 2-6, 2-7	RoutingRequest 6-255
21	OtherHandBackParameters 2-18	UnsolicitedResponse 6-305, 6-306
22	OtherHandThirdParameters 2-32	Page response
23	outgoing call barring 5-222	SystemAccessType
24	Overhead Message Train 1-19	page response timer 6-400
25	Overload	InterSystemPage 6-177, 6-178
26	AnnouncementCode, Standard Announcement	InterSystemPage2 6-182, 6-183
27		MSC special MS alerting 6-33, 6-34
28		page an MS 6-27, 6-28
29		PAGEIND , 3-61, 3-66, 5-229
30		PageIndicator 1-19, 5-121,
31		InterSystemPage 6-175
32		InterSystemPage INVOKE 5-72
33		InterSystemPage2 6-180
34		InterSystemPage2 INVOKE 5-74
35		Parameter Identifier
36		ExtendedSystemMyTypeCode 5-199
37	PA	Parameter Set is encoded as follows 5-19
38	OriginationTriggers	ParameterError 5-20, 5-199, 5-333
39	PACAIndicator	PartialDial
40	PACA , 5-51, 5-220, 5-235, , (see	AnnouncementCode, Standard Announcement
41	Priority Access and Channel Assignment), 6-403	Party Involved
42	FeatureRequest 3-344, 3-345, 3-346	HandoffState 5-204
43	loading of profile parameters 6-11	Password Call Acceptance 1-19, 5-195
44	OneTimeFeatureIndicator 5-220	Password Call Acceptance (PCA) procedures
45	RoutingRequest 6-255	-
46	PACA Answer Timer 1-19,	PAT ,
47	PACA Demand Activated	path minimization
48	OneTimeFeatureIndicator, PACA	Serving MSC initiating handoff 6-42
49	PACA Demand Inactive	
50	OneTimeFeatureIndicator, PACA	
51	PACA Detection Timer 1-19,	
52	PACA Feedback Timer 1-19,	
53	PACA Level	
54	PACAIndicator	
55		
56		
57		
58		
59		
60		

P

PBX alerting 5-131	RegistrationNotification 6-238	1
PBX automatic callback 5-131	PC_SSN (Border MSC)	2
PBX distinctive alerting 1 5-131	InterSystemPage RETURN RESULT 5-73	3
PBX distinctive alerting 3 5-131	UnsolicitedResponse INVOKE 5-117	4
PBXLong	PC_SSN (Originating MSC)	5
AlertCode, Cadence	InterSystemPage INVOKE 5-72	6
PBXShortLongShort	OriginationRequest INVOKE 5-81	7
AlertCode, Cadence	RoutingRequest INVOKE 5-99	8
PBXShortShort	UnsolicitedResponse RETURN RESULT 5-118	9
AlertCode, Cadence	PC_SSN (Originating)	10
PBXShortShortLong	LocationRequest INVOKE 5-77	11
AlertCode, Cadence	PC_SSN (Serving MSC or VLR or HLR)	12
PBXShortShortShortShort	AuthenticationRequest INVOKE 5-34	13
AlertCode, Cadence	PC_SSN (Serving MSC or VLR)	14
PC	LocationRequest RETURN RESULT 5-78	15
, 5-230	RegistrationNotification INVOKE 5-94	16
StationClassMark	PC_SSN (Serving MSC)	17
PCA	RoutingRequest RETURN RESULT 5-101	18
, (see Password Call Acceptance)	PC_SSN (Serving) 6-313	19
FeatureRequest 3-333	PDN	20
LocationRequest 3-335, 3-337, 3-338, 3-339,	PDT	21
3-340	PDU	22
QualificationDirective 3-333	pending COUNT update	23
RemoteUserInteractionDirective 3-335, 3-338,	AuthenticationDirective 6-43, 6-48, 6-52, 6-	24
3-339, 3-340	53	25
RoutingRequest 3-337	AuthenticationFailureReport 6-65, 6-70, 6-71,	26
PCA call refused	6-74	27
DMH_RedirectionIndicator	AuthenticationRequest 6-80, 6-82, 6-83, 6-91	28
PCW-FA	AuthenticationStatusReport 6-95, 6-102	29
CallingFeaturesIndicator	pending SSD update	30
PC_SSN	AuthenticationDirective 6-42, 6-43, 6-44, 6-	31
, 3-23, 3-27, 3-32, 3-61, 3-62, 3-74,	47, 6-48, 6-49	32
3-76, 3-77, 3-87, 3-119, 3-123, 3-131, 3-132,	AuthenticationFailureReport 6-63, 6-65, 6-70,	33
3-159, 3-160, 5-120,	6-71, 6-73, 6-74, 6-75	34
AuthenticationRequest 6-81	AuthenticationRequest 6-81, 6-83, 6-90, 6-91	35
FeatureRequest INVOKE 5-48	AuthenticationStatusReport 6-93, 6-94, 6-95,	36
InterSystemPage 6-175	6-96, 6-101, 6-102	37
LocationRequest 6-188, 6-193, 6-194	pending Unique Challenge	38
MSC route the call externally 6-35	AuthenticationDirective 6-43, 6-47, 6-48, 6-	39
OriginationRequest 6-204	52, 6-53	40
page an MS 6-28	AuthenticationFailureReport 6-64, 6-65, 6-70,	41
RegistrationNotification 6-238, 6-240, 6-244	6-71, 6-73, 6-74	42
RoutingRequest 6-250, 6-253, 6-259, 6-260	AuthenticationRequest 6-80, 6-82, 6-83, 6-88,	43
Serving MSC	6-90, 6-91	44
RegistrationNotification 6-233	AuthenticationStatusReport 6-95, 6-101, 6-	45
Type	102	46
Home MSC	Per Agreement	47
LocationRequest 6-188	AuthorizationPeriod	48
Originating MSC	DeniedAuthorizationPeriod	49
LocationRequest 6-188		50
UnsolicitedResponse 6-304, 6-305, 6-306		51
VLR		52

1	Per Call	MSC analyze MS dialed number 6-18
2	AuthorizationPeriod	MSC special MS alerting 6-33
3	DeniedAuthorizationPeriod	OriginationRequest 6-201
4	Period	TransferToNumberRequest 6-296
5	DeniedAuthorizationPeriod 5-182	Play Prompt
6	RANDValidTime 5-241	RemoteUserInteractionDirective 6-246, 6-247
7	Permanent Activation	Plexsys 5-300
8	PACAIndicator	PLIND , 5-233
9	Personal Identification Number 1-19	PN
10	PFT ,	Point Code 1-19, 5-230
11	PIC , 3-107	Point Code and Subsystem Number 1-19
12	PILOT , 5-232	Point CodeΔCluster Number
13	PILOTBID , 5-231	DigitsType 5-325
14	PilotBillingID 1-19, 5-126,	SMS_Address 5-260
15	InterSystemPage INVOKE 5-72, 5-118	Point CodeΔMember Number
16	RoutingRequest INVOKE 5-99	DigitsType 5-325
17	TransferToNumberRequest 6-296	SMS_Address 5-260
18	TransferToNumberRequest INVOKE 5-110	Point CodeΔNetwork Number
19	PilotNumber 1-19, 5-82, 5-126, , 6-347, 6-	DigitsType 5-325
20	360, 6-361	SMS_Address 5-260
21	FeatureRequest RETURN RESULT 5-50	Portuguese
22	InterSystemPage INVOKE 5-72	PreferredLanguageIndicator
23	RoutingRequest INVOKE 5-99	Positive Acknowledgment Signal 1-14
24	TransferToNumberRequest INVOKE 5-110	Postponed
25	UnsolicitedResponse RETURN RESULT 5-118	SMS_AccessDeniedReason
26	PIN	Pound
27	PIN collect timer 6-387, 6-388	OriginationTriggers
28	Pip Tone	SPINITriggers
29	MessageWaitingNotificationType	Power Class
30	Pip Tone Active	CDMAStationClassMark 5-172
31	OneTimeFeatureIndicator, MWN	StationClassMark
32	Pip Tone Inactive	Power down registration
33	OneTimeFeatureIndicator, MWN	SystemAccessType
34	PipPipPipPip	Power-Off Deregistration
35	AlertCode, Cadence	PPDU
36	PipTone	preemption 5-131
37	AnnouncementCode, Tone	Preferred Interexchange Carrier 1-19, 6-309, 6-
38	PL , , (see Preferred Language)	314
39	FeatureRequest 3-342	Preferred Language 1-19, 5-141, 5-233, 5-235
40	QualificationDirective 3-342	Preferred Language (PL) procedures -
41	Play All Announcements in the AnnouncementList	PreferredLanguageIndicator 1-19, 3-93, 3-100, 3-
42	, 6-422, 6-424, 6-426, 6-428, 6-430, 6-432, 6-	121, 5-125,
43	434, 6-436, 6-438, 6-440, 6-442, 6-444, 6-446, 6-	HLR analyze MS dialed number 6-19
44	448, 6-450, 6-452, 6-454, 6-456, 6-458, 6-460, 6-	loading of profile parameters 6-11
45	462	MSC analyze MS dialed number 6-15
46	FeatureRequest 6-127	Profile 5-234
47	idle MS origination 6-13	QualificationDirective INVOKE 5-234
48	incoming call attempt 6-25	QualificationRequest RETURN RESULT 5-234
49	LocationRequest 6-189, 6-190	RegistrationNotification RETURN RESULT 5-
50		
51		
52		
53		
54		
55		
56		
57		
58		
59		
60		

234	terminating call tasks	-	1
Presentation Allowed	voice feature service	- , -	2
DigitsType, Nature of Number			3
Presentation Protocol Data Unit 1-20	Procedures for RANDC Verification		4
Presentation Restricted	AuthenticationRequest 6-76		5
DigitsType, Nature of Number	RandomVariableRequest 6-219		6
Preventative Action for Dual Seizure 4-20	Procedures for SSD Management at AC		7
Prior agreement	Process collision		8
OriginationIndicator	DenyAccess, Reason		9
OriginationTriggers	Profile		10
SPINITriggers	loading of profile parameters 6-10, 6-11, 6-12		11
Priority Access and Channel Assignment 1-19	QualificationDirective INVOKE 5-84		12
MS termination alerting 6-32	QualificationRequest RETURN RESULT 5-87		13
OneTimeFeatureIndicator 5-221	RegistrationNotification RETURN RESULT 5-96		14
Priority Access and Channel Assignment (PACA) 5-51, 5-220, 5-228, 5-235	TransactionCapability		15
Priority Access and Channel Assignment (PACA) procedures -	Profile macro 5-96		16
Priority Call Waiting FeatureActivity 5-154	Profile only		17
Priority CW 5-220	QualificationInformationCode		18
OneTimeFeatureIndicator, CWFI	Protocol Data Unit 1-19		19
OneTimeFeatureIndicator, CWIC	Protocol Extension		20
Priority Level	Pseudo random noise 1-20		21
PACAIndicator	PSTN , 1-24,		22
PriorityAdditionalCallTone	PSTN Tandem		23
AnnouncementCode, Tone	DMH_RedirectionIndicator		24
PRIVATE 1-8	PSTNTERM , 5-236		25
Private Long Code Mask 5-322	PSTN Termination 1-20, 5-83, 5-111, 5-122, ,		26
private network hop-on point	6-314, 6-344, 6-345, 6-358, 6-387, 6-397, 6-398, 6-422, 6-424, 6-428, 6-430, 6-432, 6-434, 6-436, 6-440, 6-442, 6-444, 6-446, 6-448, 6-450, 6-452, 6-454, 6-456, 6-458, 6-460, 6-462		27
MSC route the call externally 6-35	HLR analyze MS dialed number 6-19		28
Private Numbering Plan	LocationRequest 6-193		29
DigitsType, Numbering Plan	MSC analyze MS dialed number 6-18		30
Private Tandem	MSC route the call externally 6-37		31
DMH_RedirectionIndicator	MSC Routing Points of Return 6-22		32
Private TCAP 5-22	originating call sent 6-22		33
PrivateLongCodeMask 5-169	OriginationRequest 6-202, 6-203		34
procedures	TerminationList 5-309		35
authentication response verification -	TransferToNumberRequest 6-300, 6-301		36
basic call processing -	Public Data Network 1-19		37
disconnect call tasks -	Public Switched Telephone Network 1-20, 1-24,		38
handoff call tasks -			39
origination call tasks -			40
RANDC verification			41
recovery call tasks			42
registration call tasks -			43
short message service -			44
signal strength arbitration			45
SSD management -			46

Q

Q reference point		55
QDT , 5-84,		56

1 QOS
 2 QRT , 5-86,
 3 QUALCODE , 3-90, 3-92, 3-94, 3-95, 3-96, 3-
 4 98, 3-99, 3-102, 3-103, 3-119, 5-237
 5
 6 QUALCOMM 5-300
 7 QUALDIR , 3-89
 8 Qualification Directive Timer 1-20,
 9 Qualification Request Timer 1-20,
 10 QualificationDirective 1-20, 5-7, 5-24, 5-28, ,
 11 5-85, 6-403
 12 operation components
 13 Invoke
 14 LOCID 3-91
 15 MessageWaitingNotificationCount 3-
 16 310
 17 MessageWaitingNotificationType 3-
 18 309, 3-310, 3-313, 3-314
 19 PreferredLanguageIndicator 3-342
 20 Return Result
 21 empty 3-90, 3-91
 22 operation definition 3-89-3-96, 5-84-5-85
 23 operation usage
 24 CD 3-215
 25 CFB 3-237
 26 CFD 3-241
 27 CFNA 3-245
 28 CFU 3-247
 29 CW 3-250
 30 DND 3-285
 31 FA 3-287
 32 general 3-203, 3-204, 3-207, 3-208
 33 MAH 3-315
 34 MWN 3-306, 3-309, 3-310, 3-313, 3-314
 35 PCA 3-333
 36 PL 3-342
 37 SCA 3-350
 38 SPINA 3-358
 39 VP 3-372
 40 RoutingRequest 6-253, 6-260, 6-261
 41 wait for TLDN call 6-26
 42 QualificationDirective procedures -
 43 QualificationInformationCode 1-20, 5-119, ,
 44 6-237
 45 Profile only
 46 QualificationDirective 6-205, 6-208
 47 QualificationRequest 6-213, 6-216
 48 RegistrationNotification 6-237, 6-242
 49 QualificationDirective INVOKE 5-84
 50 QualificationRequest 6-210, 6-216
 51 QualificationRequest INVOKE 5-86
 52 RegistrationNotification 6-233, 6-237
 53 RegistrationNotification INVOKE 5-94
 54 Validation and profile
 55 QualificationDirective 6-205, 6-208
 56 QualificationRequest 6-213, 6-216
 57 RegistrationNotification 6-237, 6-242
 58 Validation only
 59 QualificationDirective 6-205, 6-208
 60 QualificationRequest 6-213, 6-216
 RegistrationNotification 6-237, 6-242
 QualificationRequest 1-20, 5-7, 5-24, 5-28, ,
 5-87, 6-403
 operation definition 3-97-3-103, 5-86-5-87
 operation usage
 CD 3-217
 general 3-209, 3-210
 MWN 3-313, 3-314
 QualificationRequest procedures -
 Quality of Service 1-20
 QUALREQ , 3-97

R

R-Data *6-412*
 R-DataReject *6-412*
 Radio Frequency 1-20
 Radio interface incompatibility
 SMS_CauseCode
 Radio interface resource shortage
 SMS_CauseCode
 RAND , 3-23, 3-67, 3-105, 5-239, 5-241
 RANDBS , 3-42, 5-239
 RANDC , 3-67, 3-105, 5-123,
 InterSystemPage2 6-183
 InterSystemPage2 RETURN RESULT 5-75
 RandomVariableRequest 6-218
 RandomVariableRequest INVOKE 5-88
 verification procedures
 RANDC mismatch
 ReportType
 RANDC verification procedures
 Random Variable 5-238
 Random Variable Request Timer 1-20,
 RandomVariable 1-20, 5-120,
 AuthenticationRequest INVOKE 5-34
 InterSystemPage2 RETURN RESULT 5-75
 RandomVariableRequest RETURN RESULT 5-

88	60		
RandomVariable (RAND)	AuthenticationFailureReport 6-64, 6-70, 6-73,		1
AuthenticationRequest 6-76, 6-84, 6-87, 6-92	6-74		2
InterSystemPage2 6-181, 6-183	AuthenticationRequest 6-80, 6-82, 6-88, 6-90		3
RandomVariableRequest 6-218, 6-219	AuthenticationStatusReport 6-94, 6-95, 6-101		4
RandomVariableBaseStation 1-20, 5-120,	InterSystemPage2 6-182		5
BaseStationChallenge INVOKE 5-38	MSC receiving authentication parameters 6-54,		6
RandomVariableBaseStation (RANDBS)	6-55		7
BaseStationChallenge 6-104, 6-108	RANDREQ , 3-104		8
MSC receiving authentication parameters 6-54	RANDRT , 5-88,		9
RandomVariableRequest 1-20, 5-7, 5-25, 5-28,	RANDSSD , 3-8, 3-10, 3-24, 3-39, 5-240		10
, 6-403	RANDU , 3-8, 3-10, 3-13, 3-15, 3-18, 3-24,		11
operation components	3-32, 3-33, 3-35, 3-39, 3-40, 5-240		12
Return Result	RANDValidTime 1-20, 5-125,		13
empty 3-105	RandomVariableRequest 6-218, 6-219		14
operation definition 3-104-3-105, 5-88	RandomVariableRequest RETURN RESULT 5-		15
RandomVariableRequest procedures -	88		16
RandomVariableSSD 5-120,	RANDVT , 3-105, 5-241		17
AuthenticationDirective INVOKE 5-29	RB , , 4-15		18
AuthenticationFailureReport RETURN RESULT			19
5-33	SMS_TerminationRestrictions		20
AuthenticationRequest RETURN RESULT 5-	RCT , 5-92,		21
35	RDRT , 5-91,		22
AuthenticationStatusReport RETURN RESULT	RDRT , 5-89,		23
5-37	Rec.		24
RandomVariableSSD (RANDSSD)	Rec. T.50 1-17		25
AuthenticationDirective 6-42, 6-47, 6-50, 6-	RecallDialTone		26
52	AnnouncementCode, Tone		27
AuthenticationFailureReport 6-63, 6-64, 6-69,	Receipt Of Unreasonable Signaling Information 4-		28
6-73	23		29
AuthenticationRequest 6-81, 6-82, 6-90	Received Signal Strength		30
AuthenticationStatusReport 6-94, 6-101	arbitration procedures		31
MSC receiving authentication parameters 6-53	Received Signal Strength Indication 1-21		32
6-54	ReceivedSignalQuality 1-21, 3-115, 3-117, 3-120,		33
RandomVariableSSDUpdate 1-20	3-125, 5-96, 5-121, , 6-464, 6-465, 6-467,		34
RandomVariableUniqueChallenge 1-20, 5-120,	6-468		35
AuthenticationDirective INVOKE 5-29	RegistrationCancellation 6-227		36
AuthenticationDirectiveForward INVOKE 5-31	RegistrationCancellation INVOKE 5-92		37
AuthenticationFailureReport RETURN RESULT	RegistrationCancellation RETURN RESULT 5-		38
5-33	93		39
AuthenticationRequest RETURN RESULT 5-	RegistrationNotification 6-233, 6-235, 6-241,		40
35	6-242		41
AuthenticationStatusReport RETURN RESULT	RegistrationNotification INVOKE 5-94		42
5-37	RegistrationNotification RETURN RESULT 5-		43
RandomVariableUniqueChallenge (RANDU)	96		44
AuthenticationDirective 6-43, 6-47, 6-48, 6-	Recommendation 1-20		45
50, 6-52	recovery call task procedures 6-41		46
AuthenticationDirectiveForward 6-58, 6-59, 6-REDDIR	Recovery Call Tasks		47
, 3-106			48

1	REDIND , 5-194	RedirectionDirective INVOKE 5-89
2	RedirectCall	RoutingRequest 6-259
3	AnnouncementCode, Standard Announcement	RoutingRequest INVOKE 5-99
4		TransferToNumberRequest RETURN RESULT
5	RedirectingNumberDigits 1-20, 5-123, , 6-	5-111
6	332, 6-333, 6-335, 6-336	UnsolicitedResponse RETURN RESULT 5-118
7	FeatureRequest RETURN RESULT 5-50	Redirection Directive Timer 1-20,
8	LocationRequest 6-188	Redirection Indicator
9	LocationRequest INVOKE 5-77	DMH_RedirectionIndicator , 5-195
10	LocationRequest RETURN RESULT 5-78	Redirection Request Timer 1-20,
11	OriginationRequest RETURN RESULT 5-82	RedirectionDirective 1-20, 5-7, 5-25, 5-28, ,
12	Presentation Allowed 6-336	5-90, 6-403
13	presentation restricted 6-335, 6-336	operation definition 3-106-3-108, 5-89-5-90
14	TransferToNumberRequest RETURN RESULT	RedirectionDirective 6-221
15	5-111	RedirectionDirective procedures -
16	RedirectingNumberString 1-20, 3-58, 3-61, 3-66,	RedirectionReason 1-20, 5-119,
17	3-131, 3-155, 3-160, 5-123, , 6-332, 6-334,	Busy
18	6-335	MS termination alerting 6-32
19	FeatureRequest RETURN RESULT 5-50	MSC route the call externally 6-38
20	InformationDirective INVOKE 5-66	TransferToNumberRequest 6-298
21	InformationForward 6-171	DEFAULT
22	InformationForward INVOKE 5-68	TransferToNumberRequest 6-300
23	InterSystemPage 6-175	No Answer
24	InterSystemPage INVOKE 5-72	MS termination alerting 6-31
25	InterSystemPage2 INVOKE 5-74	MSC route the call externally 6-38
26	LocationRequest RETURN RESULT 5-78	TransferToNumberRequest 6-299
27	OriginationRequest RETURN RESULT 5-82	No Page Response
28	RedirectionDirective 6-220	MS termination alerting 6-29
29	RedirectionDirective INVOKE 5-89	TransferToNumberRequest 6-298
30	RoutingRequest 6-259	RedirectionRequest INVOKE 5-91
31	RoutingRequest INVOKE 5-99	TransferToNumberRequest 6-296, 6-298
32	TransferToNumberRequest RETURN RESULT	TransferToNumberRequest INVOKE 5-110
33	5-111	Unconditional
34	UnsolicitedResponse RETURN RESULT 5-118	TransferToNumberRequest 6-299
35	RedirectingSubaddress 1-21, 3-58, 3-61, 3-66, 3-	wait for TLDN call 6-26
36	131, 3-155, 3-160, 5-123, , 6-332, 6-333,	Unroutable
37	6-334	MSC route the call externally 6-38
38	FeatureRequest RETURN RESULT 5-50	TransferToNumberRequest 6-299
39	InformationDirective INVOKE 5-66	RedirectionRequest 1-20, 5-7, 5-25, 5-28, ,
40	InformationForward 6-171	5-235, 5-312, 5-313, 5-314, 6-403
41	InformationForward INVOKE 5-68	operation definition 3-109-3-111, 5-91
42	InterSystemPage 6-175	operation usage
43	InterSystemPage INVOKE 5-72	CFB 3-240
44	InterSystemPage2 INVOKE 5-74	CFD 3-241, 3-244
45	LocationRequest 6-188	CFNA 3-246, 3-271
46	LocationRequest INVOKE 5-77	DND 3-286
47	LocationRequest RETURN RESULT 5-78	FA 3-296
48	OriginationRequest RETURN RESULT 5-82	MAH 3-325
49	RedirectionDirective 6-220	RedirectionRequest 6-223, 6-224

RedirectionRequest procedures -	operation usage	1
REDREASON , 3-110, 3-154, 5-245	CD 3-224, 3-227	2
REDREQ , 3-109	general 3-214	3
ReEnterDirectoryNumberPrompt	procedures -	4
AnnouncementCode, Standard Announcement	QualificationDirective 6-206	5
	QualificationRequest 6-212, 6-213	6
ReEnterNewPINPrompt	RegistrationCancellation 6-226, 6-227	7
AnnouncementCode, Standard Announcement	REGNOT , 3-118, 3-375, 3-397, 3-400, 3-401, 3-402	8
	reject problem specifier 6-262, 6-265, 6-270, 6-271	9
ReEnterNewPINSendPrompt		10
AnnouncementCode, Standard Announcement	SMSDeliveryBackward 6-262	11
	SMSDeliveryForward 6-265	12
ReEnterPINPrompt	SMSDeliveryPointToPoint 6-270	13
AnnouncementCode, Standard Announcement	ReleaseReason 1-20, 2-14, 5-119,	14
	clear forward	15
ReEnterPINSendPrompt	FacilitiesDirective 6-123	16
AnnouncementCode, Standard Announcement	InterSystemAnswer 6-173, 6-174	17
	FacilitiesRelease 6-124, 6-126	18
RefuseCall	FacilitiesRelease INVOKE 5-47	19
AnnouncementCode, Standard Announcement	HandoffSuccessful	20
	HandoffBack 6-148	21
REGCANC , 3-112, 3-396, 3-397, 3-399, 3-400, 3-401, 3-402, 3-404	RELREASON , 5-246	22
Register the MS 6-236, 6-237	Remote Feature Control 1-20	23
Registered	Remote Feature Control (RFC) procedures -	24
Registration		25
Registration Call Tasks 6-9	Remote Feature Control Port	26
registration call tasks procedures 6-9-6-10	Remote Feature Control port access	27
Registration Cancellation Timer 1-20,	TerminationAccessType	28
Registration Notification	Remote Operation 1-20	29
QualificationDirective 6-206	Remote User Interaction 1-21	30
QualificationRequest 6-212, 6-213	TransactionCapability	31
Registration Notification Timer 1-20,	Remote User Interaction Directive Response Timer	32
registration, power down 5-296		33
RegistrationCancellation 1-20, 5-7, 5-24, 5-28, 5-93, 5-161, 6-403, 6-463, 6-464, 6-465, 6-467, 6-468	Remote User Interaction Directive Timer 1-21	34
operation components	RemoteFeatureControlRequest 5-48	35
Return Result	operation definition 5-48-5-51	36
COUNT 3-201	RemoteFeatureOperationResult 5-200	37
operation definition 3-112-3-117, 5-92-5-93	Remotely Blocked 1-20, 4-11, 4-12, 4-21, 4-22	38
operation usage	RemoteUserInteraction 6-365, 6-366, 6-369, 6-375, 6-380, 6-382, 6-383, 6-384, 6-386, 6-387, 6-388, 6-389, 6-391, 6-392	39
CD 3-224, 3-227	RemoteUserInteractionDirective 1-21, 5-7, 5-25, 5-26, 5-28, 6-374, 6-401, 6-402, 6-403, 6-404	40
RegistrationNotification 6-242	FeatureRequest 6-128	41
RegistrationCancellation procedures -	LocationRequest 6-190	42
RegistrationNotification 1-20, 5-7, 5-24, 5-28, 5-96, 6-403, 6-463, 6-464, 6-465, 6-466, 6-467, 6-468	operation definition 3-127-3-128, 5-97	43
operation definition 3-118-3-125, 5-94-5-96		44

1	operation usage	AuthenticationRequest 6-78
2	PCA 3-335, 3-338, 3-339, 3-340	ReportType (RPTTYP)
3	RFC 3-349	Missing authentication parameters
4	SPINA 3-358	RegistrationNotification 6-233
5	SPINI 3-364, 3-366	RequestedServiceInfo 2-10, 2-21, 2-35
6	OriginationRequest 6-202	RequestedTargetInfo 2-11, 2-22, 2-36
7	TransferToNumberRequest 6-297	Require0Plus
8	RemoteUserInteractionDirective procedures	AnnouncementCode, Standard Announcement
9	-	
10		
11	ReorderTone	Require0PlusNPA
12	AnnouncementCode, Tone	AnnouncementCode, Standard Announcement
13	ReportInCall	
14	CancellationType	Require1Plus
15	ReportType 1-20, 3-20, 3-119, 5-32, 5-120,	AnnouncementCode, Standard Announcement
16	AuthenticationFailureReport 6-61, 6-69, 6-72	
17	AuthenticationFailureReport INVOKE 5-32	Require10Plus
18	AuthenticationStatusReport 6-93	AnnouncementCode, Standard Announcement
19	AUTHR mismatch	
20	AuthenticationRequest 6-79	Require1PlusNPA
21	COUNT mismatch 5-32	AnnouncementCode, Standard Announcement
22	AuthenticationFailureReport 6-66, 6-68,	
23	6-72	RequireNPA
24	AuthenticationRequest 6-79	AnnouncementCode, Standard Announcement
25	AuthenticationStatusReport 6-97, 6-100,	
26	6-103	Reset Circuit Signal 4-21
27	Count update no response	Reset Circuit Timer 1-21
28	AuthenticationFailureReport 6-66, 6-68,	Reset of Circuits 4-21
29	6-72	ResetCircuit 1-20, 4-2, 4-9, 4-10, 4-11, 4-12, 4-
30	AuthenticationStatusReport 6-97, 6-100,	15, 4-18, 4-21, 4-22, 4-23, 4-24, 5-7, 5-24, 5-
31	6-103	28,
32	COUNT update successful	operation definition 4-6, 5-98
33	AuthenticationFailureReport 6-66, 6-68,	ResetCircuit Timer
34	6-72	RESETCKT , 4-6
35	AuthenticationStatusReport 6-97, 6-100,	Resolution
36	6-103	MSLocation 5-216
37	MIN/ESN Mismatch	Resource Shortage 5-22
38	AuthenticationRequest 6-78	ResourceShortage 5-20, 5-22
39	Missing authentication parameters	Restricted 6-334
40	AuthenticationRequest 6-76, 6-79	RestrictedFeatureCode
41	RANDC mismatch	AnnouncementCode, Standard Announcement
42	AuthenticationRequest 6-76	
43	InterSystemPage2 6-181	restriction, digits 5-190
44	RegistrationNotification INVOKE 5-94	RestrictionDigits 5-96, 5-125,
45	SSD update successful	loading of profile parameters 6-11
46	AuthenticationFailureReport 6-66, 6-68,	Profile 5-234
47	6-72	QualificationDirective INVOKE 5-234
48	AuthenticationStatusReport 6-97, 6-100,	QualificationRequest RETURN RESULT 5-234
49	6-103	RegistrationNotification RETURN RESULT 5-
50	TERMTYP mismatch	234
51		
52		
53		
54		
55		
56		
57		
58		
59		
60		

restrictions 1-32	AnnouncementCode, Standard Announcement	1
RETURN ERROR 5-23		2
RETURN ERROR Parameters 5-19	ROUTDGTS , 3-52, 5-249	3
return message on error 5-8, 5-11	Route the message	4
RETURN RESULT 5-23	Routing Failure Trigger	5
Reverse Charges	TerminationTriggers	6
SMS_TerminationRestrictions	Routing Number	7
revertive	DigitsType, Type of Digits	8
MSC analyze MS dialed number 6-17	Routing Request Timer 1-20,	9
Revertive Call	RoutingDigits 1-20, 3-75, 3-76, 3-77, 3-79, 3-87,	10
OriginationTriggers	3-93, 3-100, 3-121, 5-125, 5-236, , 6-309	11
SPINITriggers	FeatureRequest RETURN RESULT 5-50	12
revertive treatment	IntersystemTermination 5-206	13
FA	loading of profile parameters 6-11	14
HLR analyze MS dialed number 6-19	LocalTermination 5-208	15
LocationRequest 6-191	LocationRequest RETURN RESULT 5-78	16
MAH	MS termination alerting 6-30, 6-32	17
HLR analyze MS dialed number 6-19	MSC route the call externally 6-35, 6-36, 6-37	18
LocationRequest 6-191	OriginationRequest RETURN RESULT 5-82	19
VMR	Profile 5-234	20
HLR analyze MS dialed number 6-19	QualificationDirective INVOKE 5-234	21
LocationRequest 6-191	QualificationRequest RETURN RESULT 5-234	22
Revision Number	RegistrationNotification RETURN RESULT 5-	23
CDMAMobileProtocolRevision 5-167	234	24
RF ,	RoutingFailureTrigger	25
RFC , , (Remote Feature Control)	originating call sent 6-22, 6-23	26
LocationRequest 3-349	RoutingRequest 1-20, 5-7, 5-24, 5-28, 5-72, 5-74,	27
RemoteUserInteractionDirective 3-349	5-91, , 5-101, 5-110, 5-118, 5-220, 6-403	28
RFC Port	operation components	29
incoming call attempt 6-25	Invoke	30
RFCPointOfReturn 6-370, 6-371, 6-372, 6-373, 6-	CallingPartyNumberString1 3-258, 3-	31
374	260, 3-261	32
RFCT 6-129, , 6-405	CallingPartyNumberString2 3-258, 3-	33
RingBack	260, 3-261	34
AnnouncementCode, Tone	CallingPartySubaddress 3-258, 3-260,	35
RNDGTS , 3-155, 5-242	3-261	36
RNSTRING , 5-243	OTFI 3-323	37
RNT , 5-94, 6-234, 6-238, 6-239,	RedirectingNumberString 3-258, 3-	38
RO	260, 3-261	39
Roamer Port	RedirectingSubaddress 3-258, 3-260,	40
MSC route the call externally 6-35	3-261	41
Roamer port access 5-77	operation definition 3-129-3-134, 5-99-5-101	42
TerminationAccessType 5-308	operation usage	43
Roamer Service Profile	CD 3-216, 3-219, 3-220, 3-224, 3-227, 3-	44
Roamer Validation	239, 3-274, 3-276, 3-335	45
RoamerAccessScreening	CFB 3-238	46
AnnouncementCode, Standard Announcement	CFD 3-241, 3-244	47
	CFNA 3-246, 3-271	48
RoamerIntercept	CNIP 3-255, 3-258, 3-260, 3-261	49
		50
		51
		52
		53
		54
		55
		56
		57
		58
		59
		60

1 CW 3-253
2 DND 3-286
3 FA 3-289, 3-292, 3-296, 3-304, 3-331
4 MAH 3-318, 3-319, 3-323
5 PCA 3-337
6 VMR 3-370
7
8 RoutingRequest 6-253
9 UnsolicitedResponse 6-305, 6-306, 6-307
10 wait for TLDN call 6-26
11
12 RoutingRequest procedures -
13 RoutingRequests
14 RoutingRequest 6-253
15 ROUTREQ , 3-129
16 RPTTYP , 5-247
17 RRT , 5-99, 6-250, 6-251, 6-252,
18 RSIGQUAL , 5-241
19 RSSI
20 RSTT , 4-2, 4-6, , 5-98
21 RSUB , 5-244
22 RUDT , 5-97, 6-245,
23 RUI
24 RUI-MSC
25 RUIDIR , 3-127
26 RvtC
27 OriginationTriggers
28 SPINTriggers
29
30
31
32
33 **S**
34
35
36 SADT , , 6-405
37 SAOT , , 6-405
38 SAT
39 SAT Color Code 1-21
40 SBI
41 SBT , 5-102, 6-262, 6-265, , 6-405
42 SCA , , (see Selective Call Acceptance)
43 FeatureRequest 3-350
44 LocationRequest 3-351, 3-352, 3-353, 3-354
45 QualificationDirective 3-350
46
47 SCA call refused
48 DMH_RedirectionIndicator
49
50 SCC
51 SCCP
52 SCELLID , 3-105, 5-252
53 Scenario Description Conventions
54 SCM , 5-294
55 scrambling device
56 MS termination alerting 6-30
57
58
59
60

SDCC
SDCC3-
ControlChannelData 5-180
SDCC5-
ControlChannelData 5-180
SearchWindow 5-170
SecurityStatusReport
AuthenticationFailureReport 6-62, 6-63, 6-69,
6-72
operation usage
general 3-197
Segment Counter
BillingID 5-150
FacilitiesDirective 6-117, 6-120
FacilitiesDirective (path minimization) 6-164
FacilitiesRelease 6-124
HandoffBack 6-148
HandoffToThird 6-155
InterSystemSetup 6-185
PilotBillingID 5-231
SegmentCounter
FacilitiesRelease 6-124, 6-125
SEIZTYP , 5-250
SeizureType 1-21, 4-7, 5-119,
TrunkTest INVOKE 5-113
Selected leading digits of directory number
OriginationIndicator
Selected leading digits of directory number and
local calls only
OriginationIndicator
Selective Call Acceptance 1-21, 5-195
Selective Call Acceptance (SCA) procedures
-
Sema Group Telecoms 5-300
Send the message
SMSDeliveryPointToPoint 6-281
SenderIdentificationNumber 1-21, 5-123,
AuthenticationDirective 6-44, 6-48, 6-52
AuthenticationDirective INVOKE 5-29
AuthenticationFailureReport 6-62, 6-63, 6-72
AuthenticationFailureReport INVOKE 5-32
AuthenticationRequest 6-80, 6-85
AuthenticationRequest INVOKE 5-34
AuthenticationStatusReport 6-92, 6-94, 6-98
AuthenticationStatusReport INVOKE 5-36
BaseStationChallenge 6-104, 6-106
BaseStationChallenge INVOKE 5-38
BulkDeregistration 6-110
BulkDeregistration INVOKE 5-40

CountRequest 6-112	PC_SSN, Type	1
CountRequest INVOKE 5-41	RoutingRequest 6-259	2
FeatureRequest 6-127	Serving MSC Initiating a Facilities Directive	3
FeatureRequest INVOKE 5-48	FacilitiesRelease 6-125	4
InformationDirective INVOKE 5-66	HandoffToThird 6-157	5
InterSystemPage INVOKE 5-72	Serving MSC initiating handoff 6-42	6
MSInactive 6-195, 6-197, 6-199	Serving MSC Initiating a Flash Request	7
MSInactive INVOKE 5-80	Serving MSC Initiating a Handoff	8
OriginationRequest INVOKE 5-81	Serving MSC Initiating a Handoff Back	9
QualificationDirective INVOKE 5-84	FacilitiesRelease 6-125	10
QualificationRequest 6-210, 6-211, 6-213	Serving MSC initiating handoff 6-42	11
QualificationRequest INVOKE 5-86	Serving MSC Initiating a Handoff Measurement	12
RedirectionDirective INVOKE 5-89	Request	13
RegistrationCancellation INVOKE 5-92	Serving MSC Initiating a Handoff Measurement	14
RegistrationNotification 6-237	Request2	15
RegistrationNotification INVOKE 5-94	Serving MSC Initiating a Handoff-To-Third	16
RegistrationNotification RETURN RESULT 5-96	FacilitiesRelease 6-125	17
RoutingRequest 6-250	Serving MSC Initiating a Handoff-To-Third	18
RoutingRequest INVOKE 5-99	Directive	19
UnreliableRoamerDataDirective 6-302	Serving MSC initiating handoff 6-42	20
UnreliableRoamerDataDirective INVOKE 5-116	Serving MSC Receiving an	21
SENDERIN , 3-45, 3-52, 3-157, 5-251	AuthenticationDirectiveForward INVOKE	22
SEQUENCE	Serving MSC Receiving an SMD-REQUEST	23
SEQUENCE OF	Serving Switch Number	24
SEQUENCE OF CHOICE	SystemAccessData 5-295	25
Sequential	ServingCellID 1-21, 2-5, 2-17, 2-26, 2-28, 2-31,	26
AnnouncementCode, Class	5-45, 5-56, 5-64, 5-119,	27
Serial Number	FacilitiesDirective 6-118, 6-122	28
ElectronicSerialNumber 5-196	FacilitiesDirective (path minimization) 6-164	29
Service Code	FacilitiesDirective INVOKE 5-42	30
HLR analyze MS dialed number 6-19	FacilitiesDirective2 INVOKE 5-44	31
MSC analyze MS dialed number 6-15	HandoffBack 6-144, 6-147	32
service monitor	HandoffBack INVOKE 5-53	33
MS termination alerting 6-30	HandoffBack2 INVOKE 5-55	34
Service Profile Directive Timer 1-22	HandoffMeasurementRequest 6-149	35
Service Profile Request Timer 1-22	HandoffMeasurementRequest INVOKE 5-58	36
Service Qualification	HandoffMeasurementRequest2 6-152	37
Service Specific Logic 1-22	HandoffMeasurementRequest2 INVOKE 5-59	38
ServiceAreaDenial	HandoffToThird 6-156, 6-160, 6-163	39
AnnouncementCode, Standard Announcement	HandoffToThird INVOKE 5-61	40
Serving Cell ID	HandoffToThird2 INVOKE 5-63	41
SystemAccessData 5-295	RandomVariableRequest 6-218	42
Serving MarketID	RandomVariableRequest INVOKE 5-88	43
SystemAccessData 5-295	ServingOneWayDelay 5-170	44
Serving MSC	ServingSystemOption	45
ExtendedMSCID, type	CancellationType	46
ExtendedSystemMyTypeCode	Session Protocol Data Unit 1-22	47
	SET	48
	SET OF CHOICE	49
		50
		51
		52
		53
		54
		55
		56
		57
		58
		59
		60

1	SETRESULT	, 5-252	ShortMessageDeliveryRequest	1-21
2	SetupResult	1-21, 3-71, 5-125,	ShortShort	
3		InterSystemSetup RETURN RESULT	AlertCode, Cadence	5-76
4		Successful	ShortShort5-	
5		InterSystemSetup	AlertCode, Cadence	6-186
6		Unsuccessful	ShortShortLong	
7		InterSystemSetup	AlertCode, Cadence	6-186
8	SFT	, 5-104, 6-265,	ShortShortShortShort	, 6-405
9	Shared Secret Data-A	1-22	AlertCode, Cadence	
10	Shared Secret Data-B	1-22	SID	
11	Shared SSD		Siemens	5-300
12		SystemCapabilities	Signal Strength Arbitration	
13	SharedSecretData	1-22, 5-29, 5-33, 5-35, 5-37,	Signaling	
14		5-120, 5-142,	Signaling Connection Control Part	1-21
15		AuthenticationDirective INVOKE	Signaling Message Encryption	5-42, 5-45, 5-53, 5-
16		AuthenticationFailureReport RETURN RESULT	56, 5-61, 5-64, 5-179, 5-239, 5-253	
17		5-33	AuthenticationRequest	6-77, 6-80, 6-87
18		AuthenticationRequest RETURN RESULT	ConfidentialityModes	5-35
19		35	FacilitiesDirective	6-116, 6-118, 6-121
20		AuthenticationStatusReport RETURN RESULT	FlashRequest	6-138
21		5-37	HandoffBack	6-143, 6-145, 6-146
22	SharedSecretData (SSD)	6-407	HandoffToThird	6-155, 6-157, 6-158, 6-161
23		AuthenticationDirective	InterSystemSetup	6-187
24		6-42, 6-43, 6-47, 6-	Signaling Message Encryption Capable	
25		49, 6-50, 6-52	SystemCapabilities	
26		AuthenticationFailureReport	Signaling Message Encryption Mode	1-21
27		6-63, 6-64, 6-69,	Signaling System	7 1-22
28		6-70, 6-73, 6-74, 6-75	Signaling Transfer Point	1-22
29		AuthenticationRequest	SignalingMessageEncryptionKey	1-21, 5-34, 5-52,
30		6-78, 6-79, 6-80, 6-81,	5-120,	
31		6-82, 6-88, 6-89, 6-90	AuthenticationRequest	6-77
32		AuthenticationStatusReport	AuthenticationRequest RETURN RESULT	5-
33		6-94, 6-95, 6-96,	35	
34		6-100, 6-101, 6-102	FacilitiesDirective INVOKE	5-42
35		BaseStationChallenge	FacilitiesDirective2 INVOKE	5-44
36		6-104	HandoffBack	6-147
37		CountRequest	HandoffBack INVOKE	5-53
38		6-115	HandoffBack2 INVOKE	5-55
39		MSInactive	HandoffToThird	6-160, 6-163
40		6-197, 6-199	HandoffToThird INVOKE	5-61
41		RegistrationCancellation	HandoffToThird2 INVOKE	5-63
42		6-226, 6-228	InterSystemSetup INVOKE	5-76
43	Short Message Air Delivery Timer		SignalingMessageEncryptionKey (SMEKEY)	
44	Short Message Air Origination Timer		AuthenticationRequest	6-79, 6-82, 6-83, 6-88,
45	Short Message Delivery Timer		6-89	
46	Short Message Entity	1-21, 1-24,	FacilitiesDirective	6-116, 6-121
47	Short Message Service	1-21, 5-235	FacilitiesDirective (path minimization)	6-164
48	short message service procedures	-	FlashRequest	6-138
49	Short Message Services (SMS) messages		HandoffBack	6-143, 6-146
50		MessageWaitingNotificationCount		
51	Short Message Timer	1-22		
52	Shortened Burst Indicator	1-21		
53	ShortenedBurstIndicator	5-303		
54	ShortLongShort			
55		AlertCode, Cadence		
56	ShortMessageDeliveryAcknowledge	1-21		
57	ShortMessageDeliveryNegativeAcknowledge	1-21		
58				
59				
60				

HandoffToThird 6-155, 6-158, 6-161	SMEKEY , 2-6, 2-17, 2-31, 3-27, 3-28, 3-33,	1
InterSystemSetup 6-185	3-71, 5-253	2
SignalQuality 1-21, 2-26, 5-58, 5-119, 5-241,	SMEM	3
, 5-295, 6-235	SMS	4
HandoffMeasurementRequest 6-150	loading of profile parameters 6-12	5
HandoffMeasurementRequest RETURN	SMS Air Delivery Timer 1-21	6
RESULT 5-58	SMS Air Interface Delivery Point-to-Point	7
HandoffMeasurementRequest2 6-152	SMS Air Origination Timer 1-21	8
RegistrationNotification 6-237	SMS Delivery Backward Timer 1-21,	9
TargetMeasurementInformation 5-302	SMS Delivery Forward Timer 1-21,	10
SIGQUAL , 5-254	SMS Delivery Pending Flag 1-21, 3-378, 3-380, 3-	11
Single directory number	382, 3-391, 3-392, 3-394, 3-396, 3-397, 3-399,	12
OriginationIndicator	3-400, 3-401, 3-402, 3-403, 3-404, 3-406, 3-	13
SIT	407	14
DigitCollectionControl 5-186	MSInactive 6-195, 6-198	15
sleep mode 5-94	RegistrationCancellation 6-227, 6-230, 6-231	16
Slotted capable	RegistrationNotification 6-234, 6-238, 6-242,	17
CDMAStationClassMark	6-243	18
Slotted incapable	SMSDeliveryPointToPoint 6-275, 6-276	19
CDMAStationClassMark	SMSRequest 6-289, 6-290, 6-294	20
Slotted Mode 5-72, 5-74, 5-94	SMS delivery postponed 5-262, 5-264	21
CDMAStationClassMark 5-172	SMS_CauseCode	22
Slotted Mode Indicator	SMS Not Available	23
CDMAStationClassMark 5-172	RegistrationNotification 6-243	24
SMD-ACK , 3-373, 3-376, 3-379, 3-382, 3-	SMS not supported	25
385, 3-406, 3-407, 3-413	SMS_CauseCode	26
SMD-NACK	SMS Notification Timer 1-22,	27
SMD-NAK 3-373	SMS origination denied	28
SMD-REQ , 3-374, 3-379, 3-381, 3-383, 3-	SMS_CauseCode	29
385, 3-386, 3-387, 3-389, 3-395, 3-398, 3-405,	SMS page response	30
3-407, 3-408, 3-409, 3-410, 3-412, 6-6, 6-7	SystemAccessType	31
SMD-REQUEST , 3-373, 3-376, 3-385, 3-386,	SMS Point-to-Point / 6-412	32
3-406, 3-407, 3-413	SMS Point-To-Point Timer 1-22	33
parameters -	SMS Request Timer 1-22,	34
procedures	SMS router 6-282	35
initiating MS-based SME -	SMS Router Receiving an	36
initiating MSC -	SMSDeliveryPointToPoint INVOKE	37
receiving MS-based SME - ,	SMS termination denied	38
receiving MSC , -	SMS_CauseCode	39
SMDBACK , 3-135, 3-413, 6-6	SMSACCDEN , 3-148, 3-152, 5-256	40
SMDFWD , 3-139, 3-411, 6-7	SMSADDR , 3-119, 3-148, 3-151, 3-375, 3-	41
SMDPP , 3-143, 3-375, 3-376, 3-377, 3-380,	376, 5-258	42
3-382, 3-384, 3-385, 3-391, 3-393, 3-394, 3-	SMSDeliveryBackward 1-21, 3-135, 5-7, 5-20, 5-	43
396, 3-406, 3-407, 3-411, 3-413, 6-6, 6-8	25, 5-28, , 5-103, 6-404	44
SME , 1-24,	operation definition 3-135-3-138, 5-102-5-	45
SME Initiating SMS Delivery	103	46
SME Receiving an SMSDeliveryPointToPoint	SMSDeliveryBackward procedures -	47
INVOKE	initiating MSC -	48
	receiving MSC -	49
		50
		51
		52
		53
		54
		55
		56
		57
		58
		59
		60

1	SMSDeliveryForward 1-21, 3-139, 5-7, 5-20, 5-25,	denied 6-281, 6-288
2	5-28, , 5-105, 6-404	postponed 6-281, 6-288
3	operation definition 3-139-3-142, 5-104, 5-	unavailable 6-281, 6-288
4	105	SMSRestrictions 3-375
5	SMSDeliveryForward procedures -	SMS_AccessDeniedReason 1-21, 5-125,
6	initiating MSC -	Denied 6-289
7	receiving MSC -	SMSNotification 6-285
8	SMSDeliveryPointToPoint 1-21, 5-7, 5-20, 5-25,	SMSRequest 6-288, 6-291, 6-293, 6-294,
9	5-28, , 5-107, 5-108, 6-404	6-295
10	operation definition 3-143-3-146, 5-106-5-	Invalid 6-289
11	107	SMSRequest 6-291
12	SMSDeliveryPointToPoint procedures -	Postponed 6-290
13	initiating -	SMSRequest 6-288, 6-289, 6-290, 6-291,
14	initiating Anchor MSC	6-293, 6-294, 6-295
15	initiating MC -	SMSNotification 6-286, 6-287
16	initiating SME -	SMSNotification INVOKE 5-108
17	originating MC supplementary services -	SMSRequest 6-288, 6-291, 6-293, 6-295
18		SMSRequest RETURN RESULT 5-109
19	receiving Anchor MSC -	Unavailable 6-290
20	receiving MC -	RegistrationNotification 6-243
21	receiving SME -	SMSNotification 6-285
22	SMS router -	SMSRequest 6-288, 6-291, 6-293, 6-294,
23	terminating MC supplementary services	6-295
24	SMSDPF	SMS_Address 1-21, 3-375, 3-376, 3-377, 3-391,
25	SMSMSGCNT	3-393, 3-396, 3-397, 3-399, 3-400, 3-401, 3-
26	SMSMWI	402, 3-406, 3-407, 5-123,
27	SMSNOT , 3-147, 3-396, 3-399, 3-406	RegistrationNotification 6-233, 6-236, 6-237,
28	SMSNotification 1-21, 5-7, 5-25, 5-28, , 6-	6-242, 6-243
29	286	RegistrationNotification INVOKE 5-94
30	operation definition 3-147-3-148, 5-108	SMSDeliveryPointToPoint 6-282
31	SMSNotification INVOKE 6-404	SMSNotification 6-285, 6-286, 6-287
32	SMSNotification procedures -	SMSNotification INVOKE 5-108
33	initiating HLR	SMSRequest 6-288, 6-294
34	initiating MSC -	SMSRequest RETURN RESULT 5-109
35	receiving MC -	SMS_BearerData 3-137, 3-141, 3-144, 3-145, 3-
36	SMSNotificationIndicator 3-406	375, 3-376, 3-377, 3-384, 3-385, 3-391, 3-393,
37	SMSNOTIND , 3-150	3-394, 3-406, 3-409, 3-411, 3-413, 5-123,
38	SMSREQ , 3-149, 3-375, 3-376, 3-377, 3-378,	6-413
39	3-391, 3-392, 3-396	SMSDeliveryBackward INVOKE 5-102
40	SMSRequest 1-21, 3-147, 5-7, 5-25, 5-28, 5-108,	SMSDeliveryBackward RETURN RESULT 5-
41	, 6-292, 6-404	103
42	operation definition 3-149-3-152, 5-109	SMSDeliveryForward INVOKE 5-104
43	SMSRequest procedures -	SMSDeliveryForward RETURN RESULT 5-105
44	initiating MC -	SMSDeliveryPointToPoint 6-268, 6-279, 6-280,
45	receiving HLR -	6-282
46	receiving MSC -	SMSDeliveryPointToPoint INVOKE 5-106
47	receiving VLR -	SMSDeliveryPointToPoint RETURN RESULT
48	SMSRequest result	5-107
49	accepted 6-281, 6-288	SMS_BearerData. 3-376, 3-406, 3-413
50		
51		
52		
53		
54		
55		
56		
57		
58		
59		
60		

SMS_CauseCode 3-138, 3-142, 3-146, 5-20, 5-125,	SMSDeliveryPointToPoint 6-275	1
Address translation failure	Radio interface resource shortage	2
SMD-Request 6-414, 6-415	SMD-REQUEST 6-417	3
SMSDeliveryPointToPoint 6-272, 6-279,	SMS delivery postponed	4
6-283, 6-284	SMSDeliveryPointToPoint 6-270, 6-275,	5
Address vacant	6-276	6
SMSDeliveryPointToPoint 6-279	SMS not supported	7
Destination no longer at this address	SMSDeliveryBackward 6-262	8
SMSDeliveryPointToPoint 6-276	SMSDeliveryForward 6-265	9
Destination Resource Shortage	SMSDeliveryPointToPoint 6-271, 6-279	10
SMD-Request 6-415	SMS origination denied	11
SMSDeliveryPointToPoint 6-270, 6-276,	SMSDeliveryPointToPoint 6-278	12
6-282	SMS Origination Restriction	13
Destination SME is out of service	SMSDeliveryPointToPoint 6-277	14
Encoding problem	SMS termination denied	15
SMSDeliveryBackward 6-262	SMSDeliveryPointToPoint 6-276, 6-279	16
SMSDeliveryForward 6-265	SMSDeliveryBackward 6-264	17
SMSDeliveryPointToPoint 6-271	SMSDeliveryBackward RETURN RESULT 5-	18
Invalid Teleservice ID	103	19
SMD-Request 6-414	SMSDeliveryForward 6-267	20
SMSDeliveryPointToPoint 6-273, 6-279	SMSDeliveryForward RETURN RESULT 5-105	21
Missing expected parameter	SMSDeliveryPointToPoint 6-270, 6-273, 6-275,	22
SMSDeliveryBackward 6-263	6-276, 6-277, 6-279	23
SMSDeliveryForward 6-266	SMSDeliveryPointToPoint RETURN RESULT	24
SMSDeliveryPointToPoint 6-271, 6-272,	5-107	25
6-273, 6-274, 6-278, 6-282, 6-283	Supplementary service not supported	26
Missing mandatory parameter	SMSDeliveryPointToPoint 6-278, 6-279	27
SMSDeliveryPointToPoint 6-272, 6-273	Terminal busy	28
Network failure	Terminal resource shortage	29
SMSDeliveryBackward 6-262	Unexpected parameter value	30
SMSDeliveryForward 6-264, 6-265, 6-267	Unrecognized parameter value	31
SMSDeliveryPointToPoint 6-270, 6-271,	User Data size error	32
6-276, 6-284	SMS_ChargeIndicator 3-137, 3-141, 3-144, 5-123,	33
Network resource shortage	SMSDeliveryBackward INVOKE 5-102	34
No acknowledgment	SMSDeliveryForward INVOKE 5-104	35
SMD-Request 6-413	SMSDeliveryPointToPoint 6-269, 6-274, 6-275	36
No acknowledgment from terminal	SMSDeliveryPointToPoint INVOKE 5-106	37
No page response	SMS_DestinationAddress 3-386, 5-102, 5-106, 5-	38
No response to page	123, , 6-414, 6-415	39
SMD-Request 6-413	SMSDeliveryBackward 6-261, 6-263	40
Other general problems	SMSDeliveryBackward INVOKE 5-102	41
Other network problem	SMSDeliveryForward 6-264, 6-266	42
SMSDeliveryBackward 6-262	SMSDeliveryForward INVOKE 5-104	43
SMSDeliveryForward 6-265	SMSDeliveryPointToPoint 6-269, 6-271, 6-273,	44
Other radio interface problem	6-277, 6-282, 6-283	45
SMD-Request 6-413, 6-416	SMSDeliveryPointToPoint INVOKE 5-106	46
Other terminal problem	SMS_MessageCount 1-21, 3-144, 3-406, 3-407, 5-	47
Radio interface incompatibility	123,	48
		49
		50
		51
		52
		53
		54
		55
		56
		57
		58
		59
		60

1	SMSDeliveryPointToPoint 6-269, 6-274, 6-275	SMSDeliveryBackward INVOKE 5-102
2	SMSDeliveryPointToPoint INVOKE 5-106	SMSDeliveryForward 6-264, 6-266
3	SMS_MessageCount (.i.SMSMSGCNT 5-270	SMSDeliveryPointToPoint 6-270, 6-272, 6-274,
4	SMS_MessageWaitingIndicator 1-21, 3-396, 3-397,	6-277, 6-278
5	3-400, 3-401, 3-402, 3-403, 3-404, 5-123,	SMS_OriginalOriginatingSubaddress 3-137, 3-141,
6	MSInactive 6-195, 6-197, 6-198	3-144, 5-123,
7	MSInactive INVOKE 5-80	SMSDeliveryBackward INVOKE 5-102
8	RegistrationCancellation 6-227, 6-230, 6-231	SMSDeliveryForward INVOKE 5-104
9	RegistrationCancellation RETURN RESULT 5-	SMSDeliveryPointToPoint 6-270, 6-272
10	93	SMSDeliveryPointToPoint INVOKE 5-106
11	RegistrationNotification 6-234, 6-236, 6-238,	SMS_OriginatingAddress 5-102, 5-104, 5-106, 5-
12	6-242	123, , 6-414
13	RegistrationNotification INVOKE 5-94	SMSDeliveryBackward 6-261, 6-263
14	RegistrationNotification RETURN RESULT 5-	SMSDeliveryBackward INVOKE 5-102
15	96	SMSDeliveryForward 6-264, 6-266
16	SMS_MessageWaitingIndicator (.i.SMSMWI 5-270	SMSDeliveryForward INVOKE 5-104
17	SMS_NotificationIndicator 1-21, 3-144, 3-406, 5-	SMSDeliveryPointToPoint 6-269, 6-272, 6-274,
18	123,	6-278, 6-283
19	Do Not Notify When Available	SMSDeliveryPointToPoint INVOKE 5-106
20	SMSDeliveryPointToPoint 6-267, 6-268,	SMS_OriginationRestrictions 3-93, 3-100, 3-121,
21	6-275, 6-276, 6-281, 6-282	3-375, 5-123,
22	SMSRequest 6-288, 6-290, 6-294	Force Message Center
23	Notify When Available	SMSDeliveryPointToPoint 6-277
24	SMSDeliveryPointToPoint 6-267, 6-268,	loading of profile parameters 6-12
25	6-281	Profile 5-234
26	SMSDeliveryPointToPoint 6-269, 6-274	QualificationDirective INVOKE 5-234
27	SMSDeliveryPointToPoint INVOKE 5-106	QualificationRequest RETURN RESULT 5-234
28	SMSRequest 6-295	RegistrationNotification RETURN RESULT 5-
29	SMSRequest INVOKE 5-109	234
30	SMS_NotificationIndicator (.i.SMSNOTIND 5-271	SMSDeliveryPointToPoint 6-277
31	SMS_OriginalDestinationAddress 3-137, 3-141, 3-	SMS_TeleserviceIdentifier 3-137, 3-141, 3-144, 3-
32	144, 3-375, 3-376, 3-385, 3-406, 3-411, 3-413,	375, 3-376, 3-385, 3-406, 3-411, 3-413, 5-123,
33	5-123, , 6-414, 6-415	, 6-413
34	SMSDeliveryBackward 6-261, 6-263	SMSDeliveryBackward INVOKE 5-102
35	SMSDeliveryForward 6-264, 6-266	SMSDeliveryForward INVOKE 5-104
36	SMSDeliveryForward INVOKE 5-104	SMSDeliveryPointToPoint 6-268, 6-279, 6-280,
37	SMSDeliveryPointToPoint 6-269, 6-271, 6-273,	6-282
38	6-278, 6-282	SMSDeliveryPointToPoint INVOKE 5-106
39	SMSDeliveryPointToPoint INVOKE 5-106	SMSRequest 6-288, 6-289, 6-292
40	SMS_OriginalDestinationSubaddress 3-137, 3-141,	SMSRequest INVOKE 5-109
41	3-144, 5-123, , 6-415	SMS_TerminationRestrictions 3-93, 3-100, 3-121,
42	SMSDeliveryBackward INVOKE 5-102	3-375, 5-123,
43	SMSDeliveryForward INVOKE 5-104	loading of profile parameters 6-12
44	SMSDeliveryPointToPoint 6-269, 6-272	Profile 5-234
45	SMSDeliveryPointToPoint INVOKE 5-106	QualificationDirective INVOKE 5-234
46	SMS_OriginalOriginatingAddress 3-137, 3-141, 3-	QualificationRequest RETURN RESULT 5-234
47	144, 3-375, 3-376, 3-385, 3-406, 3-411, 3-413,	RegistrationNotification RETURN RESULT 5-
48	5-123, , 6-414, 6-415	234
49	SMSDeliveryBackward 6-261, 6-263	SMSDeliveryPointToPoint 6-274

SMT	, 5-106, 6-270, 6-271, 6-284	SSD Update failed	1
SMTmobile	, 6-405	ReportType	2
SMTnetwork	, 6-405	SSDUpdateReport	3
SNT	, 5-108, 6-285, 6-286,	SSD Update failure	4
Spanish		DenyAccess, Reason	5
PreferredLanguageIndicator		SSD Update no response	6
SPDT		ReportType	7
SPDU		SSDUpdateReport	8
SpecialFeatureRelease		SSD Update not attempted 5-293	9
ReleaseReason		SSDUpdateReport	10
SpecialInterdigitTime		SSD Update successful	11
DigitCollectionControl	5-186	SSDUpdateReport	12
SPINA	, (see Subscriber PIN Access)	SSD-A	13
FeatureRequest	3-356, 3-358, 3-360	SSD-B	14
QualificationDirective	3-358	SSDNotShared 1-19, 5-121,	15
RemoteUserInteractionDirective	3-358	AuthenticationDirective INVOKE 5-29	16
SPINI	, 5-235, 5-286, 5-287, 5-316,	AuthenticationFailureReport RETURN RESULT	17
(see Subscriber PIN Intercept)		5-33	18
FeatureRequest	3-362	AuthenticationRequest RETURN RESULT 5-	19
local SPINI operation		35	20
loading of profile parameters	6-12	AuthenticationStatusReport RETURN RESULT	21
OriginationRequest	3-364, 3-365, 3-366	5-37	22
RemoteUserInteractionDirective	3-364, 3-366	SSDNotShared (NOSSD)	23
SPINIPIN	, 3-93, 3-100, 3-121, 5-126,	AuthenticationDirective 6-42, 6-47, 6-51, 6-	24
loading of profile parameters	6-12	52	25
Profile	5-234	AuthenticationFailureReport 6-63, 6-69, 6-73	26
QualificationDirective	INVOKE 5-234	AuthenticationRequest 6-81, 6-89	27
QualificationRequest	RETURN RESULT 5-234	AuthenticationStatusReport 6-94, 6-100	28
RegistrationNotification	RETURN RESULT 5-	SSDUpdateReport 1-22, 3-38, 5-126,	29
234		AuthenticationStatusReport 6-92	30
SPINITriggers	3-93, 3-100, 3-121, 5-126,	AuthenticationStatusReport INVOKE 5-36	31
6-387		SSD update failed	32
loading of profile parameters	6-12	MSC receiving authentication parameters	33
MSC analyze MS dialed number	6-18	6-54	34
Profile	5-234	SSD update no response	35
QualificationDirective	INVOKE 5-234	MSC receiving authentication parameters	36
QualificationRequest	RETURN RESULT 5-234	6-54	37
RegistrationNotification	RETURN RESULT 5-	SSD update not attempted	38
234		MSC receiving authentication parameters	39
SPRT		6-53, 6-54	40
SPT		SSD update successful	41
SRT	, 5-109, 6-288, 6-289, 6-292, 6-293,	MSC receiving authentication parameters	42
		6-54, 6-55, 6-56, 6-57	43
SS7		SSDURPT	44
SSD	, 3-8, 3-24, 3-39, 5-253	, 5-293	45
SSD-A	5-253	SSL	46
SSD-B	5-253	SSN	47
SSD management procedures	-	, 5-230	48
SSD update	6-405	Standard Announcement 5-133	49
		AnnouncementCode 5-133	50
		Stanilite 5-300	51

1	Star	SuccessfulFeatureDeActivation
2	OriginationTriggers	AnnouncementCode, Standard Announcement
3	SPINITriggers	
4	State Transition Table 4-13	SuccessfulFeatureDeRegistration
5	state transitions 4-10	AnnouncementCode, Standard Announcement
6	Station Class Mark 1-21	
7	Station Number 1-23	SuccessfulFeatureRegistration
8	StationClassMark 2-5, 2-26, 2-31, 5-119,	AnnouncementCode, Standard Announcement
9	FacilitiesDirective 6-122	
10	FacilitiesDirective (path minimization) 6-164	Supervisory Audio Tone 1-21
11	FacilitiesDirective INVOKE 5-42	Supplementary Digital Color Code 1-21
12	FacilitiesDirective2 INVOKE 5-44	Supplementary Digital Color Codes
13	HandoffBack 6-147	ControlChannelData 5-180
14	HandoffMeasurementRequest 6-151	Supplementary service not supported
15	HandoffMeasurementRequest INVOKE 5-58	SMS_CauseCode
16	HandoffMeasurementRequest2 6-154	supplementary services
17	HandoffMeasurementRequest2 INVOKE 5-59	originating 6-267, 6-278, 6-279
18	HandoffToThird 6-156, 6-160, 6-163	terminating 6-279, 6-280
19	HandoffToThird INVOKE 5-61	SuspendedOrigination
20	HandoffToThird2 INVOKE 5-63	AnnouncementCode, Standard Announcement
21	Stolen unit	
22	AuthorizationDenied, Reason	SuspendedTermination
23	SMSNotification 6-287	AnnouncementCode, Standard Announcement
24	SMSRequest 6-291, 6-293, 6-295	
25	stop alerting in progress 5-131	Switch Number , 1-22,
26	STP	BillingID 5-150
27	Subaddress 5-159, 5-244, 5-275, 5-279,	ExtendedMSCID 5-197
28	Subscriber PIN Access 1-22	GeographicAuthorization 5-201
29	Subscriber PIN Access (SPINA) procedures	PilotBillingID 5-231
30		SystemAccessData 5-295
31	Subscriber PIN Intercept 1-22, 5-235	Switch Number (SWNO)
32	TransactionCapability	MSCID 5-214
33	Subscriber PIN Intercept (SPINI) 5-235, 5-286, 5-	SWNO ,
34	287, 5-316	Synacom Technology 5-300
35	Subscriber PIN Intercept (SPINI) procedures	SYSACCDATA , 5-295
36	-	SYSACCTYPE , 3-67, 3-98, 3-119, 5-296
37	Subscriber PIN Intercept PIN 1-22	SYSCAP , 3-38, 3-40, 5-297
38	Subsystem Number 1-22, 5-230	System Failure 5-23
39	Subsystem Number (SSN)	System ID 1-21
40	DigitsType 5-325	SystemAccessData 1-22, 3-115, 3-117, 3-120, 3-
41	SMS_Address 5-260	125, 5-96, 5-121,
42	Success	RegistrationCancellation 6-227
43	AlertResult	RegistrationCancellation INVOKE 5-92
44	Successful	RegistrationCancellation RETURN RESULT 5-
45	FeatureResult	93
46	SetupResult	RegistrationNotification 6-233, 6-235, 6-241,
47	SuccessfulFeatureActivation	6-242
48	AnnouncementCode, Standard Announcement	RegistrationNotification INVOKE 5-94
49		RegistrationNotification RETURN RESULT 5-
50		
51		
52		
53		
54		
55		
56		
57		
58		
59		
60		

96			
SystemAccessType 1-22, 3-20, 3-23, 3-27, 3-29, 3-32, 5-120, , 6-463	AuthenticationFailureReport 6-63		1
AuthenticationFailureReport INVOKE 5-32	CAVE Execution 5-35		2
AuthenticationRequest 6-78, 6-79, 6-88	RegistrationNotification INVOKE 5-94		3
AuthenticationRequest INVOKE 5-34	SystemCapabilities (Serving)		4
Autonomous registration 6-235	AuthenticationFailureReport INVOKE 5-32		5
AuthenticationFailureReport 6-62	AuthenticationRequest INVOKE 5-34		6
AuthenticationRequest 6-76, 6-78, 6-88	AuthenticationStatusReport INVOKE 5-36		7
registration call tasks 6-9	SystemCapabilities (SYSCAP)		8
RegistrationNotification 6-241	AUTH		9
Call Origination 5-34, 5-35	AuthenticationFailureReport 6-62		10
AuthenticationFailureReport 6-62	AuthenticationRequest 6-76		11
AuthenticationRequest 6-76, 6-77, 6-78, 6-79, 6-84, 6-86, 6-87, 6-88, 6-91, 6-92	AUTH is 0		12
idle MS origination 6-12	AuthenticationFailureReport 6-66, 6-68, 6-71		13
Flash Request 5-34	AuthenticationStatusReport 6-97, 6-99, 6-103		14
AuthenticationFailureReport 6-62	AUTH=1		15
AuthenticationRequest 6-76, 6-77, 6-80	AuthenticationRequest 6-78, 6-84, 6-86, 6-88, 6-92		16
FlashRequest 6-139	AuthenticationStatusReport 6-92		17
in call MS flash attempt 6-14	CAVE		18
FlashRequest	AuthenticationDirective 6-42, 6-43		19
AuthenticationRequest 6-87	AuthenticationFailureReport 6-70, 6-72		20
InterSystemPage2 6-181	AuthenticationRequest 6-80, 6-90		21
InterSystemPage2 RETURN RESULT 5-75	AuthenticationStatusReport 6-94, 6-101		22
Page Response 5-34, 5-35	RegistrationNotification 6-233		23
AuthenticationFailureReport 6-62	SystemFailure 5-21		24
AuthenticationRequest 6-76, 6-78, 6-79, 6-88	SystemMyTypeCode 1-19, 3-61, 3-74, 3-119, 3-131, 5-119, 5-198, , 6-235		25
authorize MS termination attempt 6-28	ExtendedSystemMyTypeCode 5-198		26
InterSystemPage2 6-183	LocationRequest 6-188		27
UnsolicitedResponse 6-304, 6-305, 6-306, 6-307	QualificationDirective 6-205, 6-208		28
Power down registration	QualificationRequest 6-210		29
AuthenticationFailureReport 6-62	RegistrationNotification 6-233, 6-235, 6-238, 6-241, 6-242, 6-243		30
AuthenticationRequest 6-76, 6-78, 6-88	RoutingRequest 6-250		31
registration call tasks 6-9	TransferToNumberRequest 6-296		32
QualificationRequest 6-210, 6-211	SystemMyTypeCode (HLR or VLR)		33
QualificationRequest INVOKE 5-86	QualificationDirective INVOKE 5-84		34
Registration 5-34	SystemMyTypeCode (MSC or VLR)		35
RegistrationNotification 6-233, 6-237	QualificationRequest INVOKE 5-86		36
RegistrationNotification INVOKE 5-94	SystemMyTypeCode (MSC)		37
SMS page response	RedirectionDirective INVOKE 5-89		38
AuthenticationRequest 6-78, 6-88	TransferToNumberRequest INVOKE 5-110		39
UnsolicitedResponse 6-305, 6-306	SystemMyTypeCode (Originating MSC)		40
UnsolicitedResponse INVOKE 5-117	InterSystemPage INVOKE 5-72		41
SystemCapabilities 1-22, 3-20, 3-23, 3-27, 3-32, 3-119, 5-29, 5-33, 5-37, 5-120,	RoutingRequest INVOKE 5-99		42
	SystemMyTypeCode (Originating)		43
	LocationRequest INVOKE 5-77		44
			45
			46
			47
			48
			49
			50
			51
			52
			53
			54
			55
			56
			57
			58
			59
			60

1	SystemMyTypeCode (Serving MSC or VLR)	FacilitiesDirective2 RETURN RESULT 5-46
2	RegistrationNotification INVOKE 5-94	HandoffBack 6-144, 6-146, 6-147
3	SystemMyTypeCode (VLR or HLR)	HandoffBack INVOKE 5-53
4	QualificationRequest RETURN RESULT 5-87	HandoffBack2 INVOKE 5-55
5	RegistrationNotification RETURN RESULT 5-	HandoffBack2 RETURN RESULT 5-57
6	96	HandoffMeasurementRequest 6-150
7		HandoffMeasurementRequest RETURN
8		RESULT 5-58
9		HandoffMeasurementRequest2 6-153
10	<u>T</u>	HandoffToThird 6-156, 6-158, 6-160, 6-161,
11		6-163
12		HandoffToThird INVOKE 5-61
13	TA	HandoffToThird2 INVOKE 5-63
14	DigitCollectionControl 5-186	HandoffToThird2 RETURN RESULT 5-65
15	Tandem 5-300	TargetMeasurementInformation 5-302
16	Tandem Depth 1-22	TargetMeasurementInformation 1-22, 5-126,
17	Tandem Handoff To Third Timer 1-22	HandoffMeasurementRequest2 6-153
18	Tandem Handoff-To-Third Timer	TargetMeasurementList 5-302
19	Tandem MSC Receiving a HandoffToThird INVOKE	TargetMeasurementList 1-22, 2-29, 5-126,
20		HandoffMeasurementRequest2 6-153
21		HandoffMeasurementRequest2 RETURN
22	FacilitiesRelease 6-125	RESULT 5-60
23	Tandem MSC Receiving an Authentication	TargetOneWayDelay 5-175
24	Directive Forward	TAT , 3-74, 5-308
25	Tandem MSC Receiving of a Flash Request	TBCD
26	TANDEMDEPTH , 5-205	TC
27	HandoffToThird 6-159, 6-160, 6-163	TCAP , 5-2, 5-14, 5-15, 5-16, 5-17, 5-18, 5-
28	Target MSC	23, 5-24, 5-26
29	Target MSC Handoff Back	TCELLID , 5-301
30	FacilitiesRelease 6-125	TDMA , , 6-410, 6-463
31	HandoffBack 6-146	TDMABurstIndicator 2-6, 2-7, 2-11, 2-12, 2-18,
32	HandoffToThird 6-158, 6-162	2-21, 2-23, 2-32, 2-35, 2-37, 5-55, 5-61, 5-120,
33	Target MSC Handoff Forward	
34	FacilitiesDirective 6-121	FacilitiesDirective 6-118, 6-121
35	FacilitiesRelease 6-125	HandoffBack 6-144, 6-146
36	Target MSC Receiving a FacilitiesDirective	HandoffToThird 6-156
37	INVOKE	TDMABurstIndicator (Serving)
38	Target MSC Receiving a HandoffBack INVOKE	FacilitiesDirective INVOKE 5-42
39		FacilitiesDirective2 INVOKE 5-44
40	Target MSC Receiving a	HandoffBack INVOKE 5-53
41	HandoffMeasurementRequest INVOKE	HandoffToThird2 INVOKE 5-63
42	Target MSC Receiving a	TDMABurstIndicator (Target)
43	HandoffMeasurementRequest2 INVOKE	FacilitiesDirective RETURN RESULT 5-43
44	TargetCellID 1-22, 2-5, 2-11, 2-12, 2-17, 2-22, 2-	FacilitiesDirective2 RETURN RESULT 5-46
45	23, 2-26, 2-31, 2-36, 2-37, 5-58, 5-119,	HandoffBack RETURN RESULT 5-54
46	CDMACodeChannelInformation 5-166	HandoffBack2 RETURN RESULT 5-57
47	CDMATargetMAHOInformation 5-173	HandoffToThird RETURN RESULT 5-62
48	CDMATargetMeasurementInformation 5-174	HandoffToThird2 RETURN RESULT 5-65
49	FacilitiesDirective 6-117, 6-118, 6-121, 6-122	TDMACallMode 1-22, 2-6, 2-11, 2-17, 2-21, 2-26,
50	FacilitiesDirective (path minimization) 6-164	
51	FacilitiesDirective INVOKE 5-42	
52	FacilitiesDirective2 INVOKE 5-44	
53		
54		
55		
56		
57		
58		
59		
60		

2-28, 2-31, 2-35, 5-120,	TeleserviceIdentifier 6-411, 6-412	1
FacilitiesDirective 6-118, 6-122	Telex Numbering	2
FacilitiesDirective INVOKE 5-42	DigitsType, Numbering Plan	3
FacilitiesDirective2 INVOKE 5-44	TELOS 5-300	4
HandoffBack 6-144, 6-147	Temporary Local Directory Number , 1-22	5
HandoffBack INVOKE 5-53	Temporary Local Directory Number (TLDN) 5-101,	6
HandoffBack2 INVOKE 5-55	5-117	7
HandoffMeasurementRequest 6-151	Temporary Local Directory Number Association	8
HandoffMeasurementRequest INVOKE 5-58	Timer 1-22	9
HandoffMeasurementRequest2 6-154	TerminalType 1-22, 3-20, 3-23, 3-32, 5-120,	10
HandoffMeasurementRequest2 INVOKE 5-59	AuthenticationFailureReport RETURN RESULT	11
HandoffToThird 6-156, 6-160, 6-163	5-33	12
HandoffToThird INVOKE 5-61	AuthenticationRequest INVOKE 5-34	13
HandoffToThird2 INVOKE 5-63	RegistrationNotification INVOKE 5-94	14
TDMACHannelData 1-22, 2-6, 2-7, 2-11, 2-12, 2-	TerminalType (TERMTYP)	15
18, 2-21, 2-23, 2-26, 2-28, 2-32, 2-35, 2-37, 5-	AuthenticationFailureReport 6-62, 6-63, 6-72,	16
120, 5-176,	6-73	17
FacilitiesDirective 6-118, 6-120, 6-121, 6-122	AuthenticationRequest 6-76, 6-77, 6-78, 6-81,	18
FacilitiesDirective (path minimization) 6-164,	6-87	19
6-165	CDMA	20
HandoffBack 6-144, 6-146, 6-147	AuthenticationRequest 6-79, 6-89	21
HandoffMeasurementRequest 6-149, 6-151	FacilitiesDirective 6-116	22
HandoffMeasurementRequest2 6-151, 6-152	HandoffBack 6-143	23
HandoffToThird 6-156, 6-157, 6-158, 6-160,	HandoffToThird 6-155	24
6-161, 6-163	FacilitiesDirective (path minimization) 6-164	25
TDMACHannelData (Serving)	RegistrationNotification 6-233	26
FacilitiesDirective INVOKE 5-42	TDMA	27
FacilitiesDirective2 INVOKE 5-44	AuthenticationRequest 6-79, 6-89	28
HandoffBack INVOKE 5-53	FacilitiesDirective 6-116	29
HandoffBack2 INVOKE 5-55	HandoffBack 6-143	30
HandoffMeasurementRequest INVOKE 5-58	HandoffToThird 6-155	31
HandoffMeasurementRequest2 INVOKE 5-59	TerminalType mismatch	32
HandoffToThird INVOKE 5-61	AuthorizationDenied, Reason	33
HandoffToThird2 INVOKE 5-63	DenyAccess, Reason	34
TDMACHannelData (Target)	terminating call task procedures 6-25-6-39	35
FacilitiesDirective RETURN RESULT 5-43	Terminating MC Supplementary Services	36
FacilitiesDirective2 RETURN RESULT 5-46	SMSDeliveryPointToPoint 6-279	37
HandoffBack RETURN RESULT 5-54	Terminating SMS supplementary service , 1-23	38
HandoffBack2 RETURN RESULT 5-57	terminating supplementary services 6-279, 6-280	39
HandoffToThird RETURN RESULT 5-62	Termination Address , 1-22	40
HandoffToThird2 RETURN RESULT 5-65	Termination Address Expansion 6-331, 6-335, 6-	41
TDMADATA , 5-305	336, 6-337, 6-338, 6-349, 6-367,	42
TDMAMODE , 5-304	HLR analyze MS dialed number 6-19	43
TDMASBI , 5-303	Termination Denied	44
TDMAShortenedBurstIndicator 1-22	AccessDeniedReason 5-128	45
Telecommunications Systems Bulletin 1-22	DMH_RedirectionIndicator	46
Telephony Binary Coded Decimal 1-22	RoutingRequest 6-254	47
Telephony Numbering	TerminationRestrictionCode	48
DigitsType, Numbering Plan	TerminationAccessType 1-22, 5-124,	49
		50
		51
		52
		53
		54
		55
		56
		57
		58
		59
		60

1 Land to MobileDirectoryNumber
 2 incoming call attempt 6-26
 3 LocationRequest 6-188
 4 LocationRequest INVOKE 5-77
 5 Mobile to MobileDirectoryNumber
 6 MSC analyze MS dialed number 6-18
 7 RemoteFeatureControlPort
 8 incoming call attempt 6-25
 9 RoamerPort.
 10 incoming call attempt 6-25
 11 TerminationList 1-22, 3-75, 3-76, 3-77, 3-79, 3-
 12 87, 3-155, 5-78, 5-79, 5-82, 5-83, 5-111, 5-124,
 13 5-206, 5-208, 5-236, , 5-316, 6-309, 6-310,
 14 6-313, 6-342, 6-343, 6-344, 6-345, 6-356, 6-
 15 357, 6-358, 6-394, 6-395
 16 FeatureRequest 6-128
 17 FeatureRequest RETURN RESULT 5-50
 18 LocationRequest 6-189
 19 LocationRequest RETURN RESULT 5-78
 20 MSC Routing Points of Return 6-20
 21 OriginationRequest 6-201, 6-203
 22 OriginationRequest RETURN RESULT 5-82
 23 TransactionCapability
 24 TransferToNumberRequest 6-297, 6-300, 6-
 25 301
 26 TransferToNumberRequest RETURN RESULT
 27 5-111
 28 TerminationRestrictionCode 1-22, 3-92, 3-100, 3-
 29 120, 5-120,
 30 loading of profile parameters 6-12
 31 Profile 5-234
 32 QualificationDirective 6-207, 6-210
 33 QualificationDirective INVOKE 5-234
 34 QualificationRequest 6-215, 6-217
 35 QualificationRequest RETURN RESULT 5-234
 36 RegistrationNotification RETURN RESULT 5-
 37 234
 38 TerminationTreatment 1-22, 5-100, 5-124, 5-206,
 39 5-208, , 6-394
 40 DEFAULT
 41 RoutingRequest 6-258
 42 DialogTermination
 43 RoutingRequest 6-258
 44 wait for TLDN call 6-27
 45 Dialogue 5-100, 5-208
 46 InterSystemPage INVOKE 5-72
 47 LocalTermination 5-208
 48 MS termination 5-100, 6-310, 6-342, 6-356,
 49 6-357
 50 RoutingRequest 6-254
 51 MSC Routing Points of Return 6-20
 52 MSTermination 6-310, 6-342
 53 RoutingRequest 6-251, 6-257
 54 wait for TLDN call 6-26
 55 RoutingRequest 6-251, 6-254, 6-256
 56 RoutingRequest INVOKE 5-99
 57 UnsolicitedResponse RETURN RESULT 5-118
 58 VoiceMailDelivery 6-397
 59 RoutingRequest 6-257
 60 VoiceMailDelivery. 6-397
 VoiceMailRetrieval 5-100, 5-208
 RoutingRequest 6-258
 wait for TLDN call 6-26
 VoiceMailStorage 5-100, 5-208
 wait for TLDN call 6-26
 wait for TLDN call 6-26
 TerminationTriggers 1-22, 3-93, 3-100, 3-121, 5-
 124, 5-236, , 6-309, 6-310, 6-341, 6-342,
 6-344, 6-345, 6-356, 6-357, 6-358
 Busy
 MS termination alerting 6-32
 MSC route the call externally 6-38
 FeatureRequest RETURN RESULT 5-50
 InterSystemPage INVOKE 5-72
 IntersystemTermination 5-206
 loading of profile parameters 6-12
 LocalTermination 5-208
 LocationRequest RETURN RESULT 5-78
 MS termination alerting 6-30
 MSC route the call externally 6-36, 6-37
 No Page Response
 MS termination alerting 6-29
 NoAnswer
 MS termination alerting 6-30
 MSC route the call externally 6-37
 None Reachable 5-110
 MS termination alerting 6-29, 6-32
 MSC route the call externally 6-38
 None Reachable (NR)
 MS termination alerting 6-31
 originating call sent 6-22
 OriginationRequest RETURN RESULT 5-82
 Profile 5-234
 QualificationDirective INVOKE 5-234
 QualificationRequest RETURN RESULT 5-234
 RegistrationNotification RETURN RESULT 5-
 234
 RoutingFailure

MSC route the call externally 6-38	330, 6-331, 6-336, 6-337, 6-338, 6-339, 6-343,	1
RoutingRequest 6-257	6-345, 6-349, 6-350, 6-358, 6-362, 6-363, 6-	2
RoutingRequest INVOKE 5-99	364, 6-365, 6-366, 6-367, 6-374, 6-375, 6-376,	3
TransferToNumberRequest RETURN RESULT	6-377, 6-378, 6-379, 6-380, 6-381, 6-382, 6-	4
5-111	383, 6-384, 6-385, 6-386, 6-387, 6-388, 6-390,	5
UnsolicitedResponse RETURN RESULT 5-118	6-391, 6-392, 6-393, 6-394, 6-395, 6-396, 6-	6
Terminator is handing off	397, 6-398, 6-399, 6-422, 6-424, 6-426, 6-428, 6-	7
HandoffState	430, 6-432, 6-434, 6-436, 6-438, 6-440, 6-442, 6-	8
TERMLIST , 3-52, 5-309	444, 6-446, 6-448, 6-450, 6-452, 6-454, 6-456, 6-	9
TERMRES , 5-310	458, 6-460, 6-462	10
TERMTRIG , 3-52, 3-61, 3-87, 3-131, 3-155,	HLR analyze MS dialed number 6-19	11
3-160, 5-312	idle MS origination 6-13	12
TERMTRMT , 3-131, 5-311	LocationRequest 6-191, 6-192	13
TERMTYP , 3-119, 5-307	MSC analyze MS dialed number 6-18	14
TERMTYP mismatch	OriginationRequest 6-202	15
ReportType	TransferToNumberRequest 6-298, 6-299, 6-	16
TEST PROCEDURES 4-26	300	17
Three-Way Calling	TPDU	18
FeatureActivity 5-154	Traffic	19
Three Way Calling 1-14	Transaction Capabilities 1-22	20
Three-Way Calling	Transaction Capabilities Application Part 1-22	21
MS termination alerting 6-32	TransactionCapability 1-22, 5-84, 5-87, 5-124, 5-	22
MSC analyze MS dialed number 6-15	235, , 6-310, 6-313, 6-342, 6-344, 6-365,	23
Three-Way Calling (6-WC) 5-221	6-369, 6-380, 6-382, 6-383, 6-384, 6-386, 6-	24
Three-Way Calling (6-WC) procedures	388, 6-389, 6-394, 6-395, 6-398	25
THTTT ,	FeatureRequest 6-127	26
TIA/EIA	FeatureRequest INVOKE 5-48	27
Time	LocationRequest 6-188	28
NoAnswerTime 5-219	LocationRequest INVOKE 5-77	29
Time Division Multiple Access 1-22	MSC analyze MS dialed number 6-15	30
Time Slot and Rate	OriginationRequest 6-201	31
TDMChannelData 5-306	OriginationRequest INVOKE 5-81	32
Time Slot and Rate Indicator 1-23	QualificationRequest 6-210, 6-211	33
timer values 4-24, 4-28, 6-400-6-405	QualificationRequest INVOKE 5-86	34
TLDN , , 3-62, 3-132, 3-159, 6-405	RegistrationNotification 6-233	35
TLDN Association Timer	RegistrationNotification INVOKE 5-94	36
TLDN Call Arrival	termination list capable 6-397	37
incoming call attempt 6-25	TransferToNumberRequest 6-296	38
TLDNAT ,	TransferToNumberRequest INVOKE 5-110	39
TMEAS , 5-302	TRANSCAP , 3-50, 3-52, 3-74, 3-79, 3-87, 3-	40
TMEASLIST , 5-302	98, 3-119, 3-154, 5-315	41
toll restriction 5-222	Transfer To Number Request Timer	42
Tone	Transfer-To Number Request Timer 1-23	43
AnnouncementCode 5-133, 5-134	TransferToNumberRequest 1-22, 5-7, 5-24, 5-28,	44
TonesOff 5-134	, 5-111, 5-235, 5-312, 5-313, 5-314, 6-405	45
AnnouncementCode, Tone	operation components	46
ToneTermination 6-308, 6-311, 6-312, 6-313, 6-	Invoke	47
314, 6-315, 6-316, 6-317, 6-318, 6-319, 6-320,	BILLID 3-317	48
6-322, 6-323, 6-324, 6-326, 6-327, 6-328, 6-	Return Result	49

1	RedirectingNumberDigits 3-271, 3-	Trunk Test Disconnect Timer 1-23,
2	276	Trunk Test Reply 4-27
3	RedirectingSubaddress 3-271, 3-276	Trunk Test Request 4-26
4	operation definition 3-153-3-156, 5-110-5-	Trunk Test Timer 1-23,
5	112	TrunkStatus 1-22, 4-6, 5-119,
6	operation usage	ResetCircuit RETURN RESULT 5-98
7	CFB 3-276	TrunkTest 1-23, 4-2, 4-17, 4-19, 4-20, 4-23, 4-25,
8	CFD 3-241, 3-244	4-28, 5-7, 5-24, 5-28,
9	CFNA 3-246, 3-271	operation definition 4-7, 5-113
10	DND 3-286	procedure 4-26-4-27
11	FA 3-296	TrunkTestDisconnect 1-23, 4-2, 4-17, 4-19, 5-7,
12	MAH 3-317, 3-326	5-24, 5-28,
13	TransferToNumberRequest procedures 6-296-	operation definition 4-8, 5-114
14		procedure 4-27
15	Transmission	TrunkUnavailable 5-20
16	StationClassMark	TSAP
17	Transmit normal burst after cell-to-cell handoff	TSB
18	TDMABurstIndicator	TSB1-1
19	Transmit normal burst after handoff within cell	AuthenticationFailureReport 6-62, 6-63, 6-69,
20	TDMABurstIndicator	6-72
21	Transmit shortened burst after cell-to-cell handoff	AuthenticationRequest 6-77, 6-81, 6-87
22	TDMABurstIndicator	TSR
23	Transport Protocol Data Unit 1-22	TDMACHannelData 5-306
24	Transport Service Access Point 1-22	TSSS ,
25	TRANUMREQ , 3-153	TTDT , 4-2, 4-8, 4-27, , 5-114
26	TraNumReqMultTerm 6-300	TTEST , 4-7
27	TraNumReqPointOfReturn 6-298, 6-299, 6-300	TTESTDISC , 4-8
28	TRNKSTAT , 5-317	TTNRT , 5-110, 6-296, 6-297,
29	trunk group identifier	TTT , 4-2, 4-7, 4-26, 4-27, , 5-113
30	TerminationAccessType 5-308	TX
31	Trunk Group Number	StationClassMark
32	InterMSCCircuitID 5-204	Type
33	Trunk Member Number	ExtendedMSCID 5-197
34	InterMSCCircuitID 5-204	ExtendedSystemMyTypeCode 5-198
35	Trunk state	PC_SSN 5-230
36	Active	Type of messages
37	FacilitiesDirective 6-122	MessageWaitingNotificationCount 5-210
38	InterSystemSetup 6-187	Type of messages not specified
39	idle 6-12, 6-352	MessageWaitingNotificationCount 5-210
40	FacilitiesRelease 6-124, 6-125, 6-127	TypeAhead 5-188
41	MS termination alerting 6-29	
42	Locally and Remotely Blocked	
43	FacilitiesDirective 6-122	
44	InterSystemSetup 6-187	
45	Locally Blocked	
46	FacilitiesDirective 6-122	
47	InterSystemSetup 6-187	
48	Trunk Test Disconnect Reply 4-27	
49	Trunk Test Disconnect Request 4-27	

U

UBLKT , 4-2, 4-5, , 5-115
UCHALRPT , 5-318
UDT
UDTS
Um reference point

Unassigned	AuthenticationStatusReport INVOKE 5-36	1
DMH_RedirectionIndicator	Unique Challenge failed	2
Unassigned directory number	AuthenticationDirectiveForward 6-58, 6-59	3
AccessDeniedReason	InterSystemPage2 6-182	4
AuthorizationDenied, Reason	MSC receiving authentication parameters	5
SMSNotification 6-287	6-55, 6-56	6
SMSRequest 6-291, 6-294, 6-295	Unique Challenge no response	7
UnauthorizedFeatureCode	AuthenticationDirectiveForward 6-58, 6-59	8
AnnouncementCode, Standard Announcement	MSC receiving authentication parameters	9
UnauthorizedMobile	6-55	10
AnnouncementCode, Standard Announcement	Unique Challenge not attempted	11
UnauthorizedUser	AuthenticationDirectiveForward 6-59	12
AnnouncementCode, Standard Announcement	InterSystemPage2 6-182	13
Unavailable , 6-334, 6-335	MSC receiving authentication parameters	14
AccessDeniedReason	6-54, 6-55	15
RedirectionReason	Unique Challenge successful	16
SMS_AccessDeniedReason	AuthenticationDirectiveForward 6-58, 6-59	17
Unavailable MS Detected GSL	InterSystemPage2 6-182	18
Unavailable Re-Routing GSL	MSC receiving authentication parameters	19
Unblocking 4-2, 4-9, 4-10, 4-11, 4-12, 4-13, 4-15, 4-18, 4-22, 4-23, 4-24, 4-25, 5-8, 5-24, 5-28,	6-56, 6-57	20
operation definition 4-5, 5-115	Unitdata 1-23	21
Unblocking Timer 1-23,	Unitdata Service 1-23	22
Unconditional	UNIVERSAL	23
RedirectionReason	04 OCTET STRING	24
Unexpected parameter value	05 NULL	25
SMS_CauseCode	10 ENUMERATED	26
Unguarded Interval 4-20	16 SEQUENCE	27
Unique Challenge failed	16 SEQUENCE OF	28
ReportType	17 SET	29
UniqueChallengeReport	2 INTEGER	30
Unique Challenge failure	Unknown	31
DenyAccess, Reason	MessageWaitingNotificationCount 5-210	32
Unique Challenge no response	Unlimited number of conferees	33
ReportType	ConferenceCallingIndicator 5-178	34
UniqueChallengeReport	Unrec	35
Unique Challenge not attempted	OriginationTriggers	36
UniqueChallengeReport	SPINITriggers	37
Unique Challenge successful	Unrecognized Number	38
UniqueChallengeReport	OriginationTriggers	39
UniqueChallengeReport 1-23, 3-18, 3-38, 3-40, 5-124,	SPINITriggers	40
AuthenticationDirectiveForward RETURN	Unrecognized Operation Code 5-333	41
RESULT 5-31	Unrecognized Package Type 5-333	42
AuthenticationStatusReport 6-92	Unrecognized parameter value 5-311	43
	SMS_CauseCode	44
	UnrecognizedESN 5-20	45
	UnrecognizedFeatureCode	46
		47
		48
		49
		50
		51
		52
		53
		54
		55
		56
		57
		58
		59
		60

1	AnnouncementCode, Standard Announcement	PilotBillingID
2		PreferredLanguageIndicator 5-233
3	UnrecognizedMIN 5-20	ReleaseReason
4	UnrecognizedParameterValue 5-21, 5-199, 5-333	SeizureType
5	Unregistered	SystemAccessType
6	UNRELDIR , 3-157	Unspecified MS inactivity type
7	Unreliable Roamer Data Directive Timer 1-23,	AvailabilityType
8		Unspecified security violation
9	UnreliableRoamerDataDirective 1-23, 5-8, 5-24, 5-	ReportType
10	28, , 6-405	Unsuccessful
11	operation definition 3-157, 5-116	FeatureResult
12	operation usage	SetupResult
13	general 3-214	Unsupported3-plus
14	UnreliableRoamerDataDirective procedures	- AnnouncementCode, Standard Announcement
15		
16	Unresponsive MS Detected GSL	Unsupported3-XXX
17	Unresponsive Re-Routing GSL	AnnouncementCode, Standard Announcement
18	Unrestricted	
19	TerminationRestrictionCode	Update COUNT
20	Unroutable	UpdateCount
21	RedirectionReason	UpdateCount 1-23, 3-12, 3-24, 3-33, 3-39, 5-121,
22	Unroutable Call Detected GSL	
23	Unroutable Call Re-Routing GSL	AuthenticationDirective INVOKE 5-29
24	Unsigned Enumerated	AuthenticationFailureReport RETURN RESULT
25	Unsigned Integer	5-33
26	Unsolicited Base Station Challenge	AuthenticationRequest RETURN RESULT 5-
27	ReportType	35
28	Unsolicited Page Response Notification	AuthenticationStatusReport RETURN RESULT
29	UnsolicitedResponse 6-305, 6-306	5-37
30	Unsolicited Response Timer 1-23,	UpdateCount (UPDCOUNT)
31	UnsolicitedPageResponse	AuthenticationDirective 6-43, 6-48, 6-52
32	page an MS 6-28	AuthenticationFailureReport 6-64, 6-70, 6-74
33	UnsolicitedResponse 6-307	AuthenticationRequest 6-80, 6-82, 6-91
34	UnsolicitedResponse 1-23, 5-8, 5-25, 5-28,	AuthenticationStatusReport 6-95, 6-102
35	5-118, 6-405	UPDCOUNT , 5-319
36	InterSystemPage2 6-184	Upper
37	operation definition 3-158-3-161, 5-117-5-	NAMPSChannelData
38	118	URDDT , 5-116,
39	operation usage	URT , 5-117,
40	CD 3-227	Usable signal range
41	RoutingRequest 6-255	SignalQuality
42	UnsolicitedResponse procedures 6-304-	User Data size error
43	UNSOLRES , 3-158	SMS_CauseCode
44	Unspecified	User provided, not screened
45	AuthorizationDenied, Reason	DigitsType, Nature of Number
46	BillingID	User provided, screening failed
47	DenyAccess, Reason	DigitsType, Nature of Number
48	FeatureRequest 6-137	User provided, screening passed
49	HandoffReason	DigitsType, Nature of Number
50		
51		
52		
53		
54		
55		
56		
57		
58		
59		
60		

User specified			
Subaddress, Type		AuthenticationRequest 6-78, 6-79	1
		AuthenticationStatusReport 6-93	2
		VLR Initiating Registration Cancellation	3
		RegistrationNotification 6-236	4
		VLR Receiving an InformationDirective INVOKE	5
			6
Vacant			7
AnnouncementCode, Standard Announcement		VLR Receiving an SMSRequest INVOKE	8
		VLR Receiving AuthenticationDirective INVOKE	9
VacantNumber			10
AnnouncementCode, Standard Announcement		VLR Receiving AuthenticationFailureReport INVOKE	11
			12
			13
Vacation disconnect		VLR Receiving AuthenticationRequest INVOKE	14
SMSNotification 6-287			15
SMSRequest 6-291, 6-294, 6-295		VLR Receiving BaseStationChallenge INVOKE	16
Validation and profile			17
QualificationInformationCode		VLR Receiving Count Request INVOKE	18
Validation only		VLR Receiving FeatureRequest INVOKE	19
QualificationInformationCode		VLR Receiving MSInactive INVOKE	20
Value		VLR Receiving QualificationDirective INVOKE	21
AuthorizationPeriod 5-148			22
DeniedAuthorizationPeriod 5-182		VLR Receiving QualificationRequest INVOKE	23
VCH		VLR Receiving RegistrationCancellation INVOKE	24
Vendor			25
SystemMyTypeCode 5-300		VLR Receiving RegistrationNotification INVOKE	26
virtual private network hop-off point			27
MSC route the call externally 6-35		VLR Receiving RoutingRequest INVOKE	28
Visited System		VLR Receiving UnreliableRoamerDataDirective INVOKE	29
Visitor Location Register , 1-23, 1-24,			30
VLR , , 1-24,		VMAC , 5-176	31
ExtendedMSCID, type		VMBOX , 3-132, 5-320	32
ExtendedSystemMyTypeCode		VMN	33
PC_SSN, Type		VMR , , (see Voice Message Retrieval)	34
VLR Awaiting AuthenticationStatusReport INVOKE		FeatureRequest 3-370	35
		OriginationRequest 3-371	36
		RoutingRequest 3-370	37
AuthenticationDirective 6-48, 6-53		VMS	38
AuthenticationFailureReport 6-65, 6-74		VMSPIN , 3-132, 5-321	39
AuthenticationRequest 6-80, 6-83		Voice Channel 1-23	40
AuthenticationStatusReport 6-95		voice feature procedures 6-308-6-396, 6-397-6-399	41
VLR Detection of MS Inactive			42
MSInactive 6-196		Voice Mail Notification	43
VLR Detection of MS Inactivity		SMS_TeleserviceIdentifier	44
VLR Initiating a Bulk Deregistration		Voice Mail Number 1-23	45
VLR Initiating a Qualification Directive		Voice Mail Retrieval 5-320	46
QualificationDirective 6-206		DMH_RedirectionIndicator	47
QualificationRequest 6-212		TerminationTreatment	48
VLR Initiating a Qualification Request		Voice Mail Storage	49
VLR Initiating an Authentication Directive		TerminationTreatment	50
VLR Initiating an Authentication Failure Report			51
			52
			53
			54
			55
			56
			57
			58
			59
			60

1	Voice Mailbox PIN 1-23	HandoffToThird INVOKE 5-61
2	Voice Message Retrieval 1-23	HandoffToThird2 INVOKE 5-63
3	Voice Message Retrieval (VMR) procedures	InterSystemSetup INVOKE 5-76
4		VoicePrivacyMask (VPMASK)
5	Voice Message System 1-23	AuthenticationRequest 6-79, 6-83, 6-85, 6-89
6	Voice messages	FacilitiesDirective 6-116, 6-121
7	MessageWaitingNotificationCount	FacilitiesDirective (path minimization) 6-164
8	Voice Mobile Attenuation Code 1-23	HandoffBack 6-143, 6-146, 6-147
9	Voice Privacy 1-23, 5-42, 5-43, 5-45, 5-53, 5-54,	HandoffToThird 6-155, 6-158, 6-160, 6-162,
10	5-56, 5-61, 5-62, 5-64, 5-179, 5-239, 5-253, 5-	6-163
11	322	InterSystemSetup 6-185
12	AuthenticationRequest 6-79, 6-85	VP , , (see Voice Privacy)
13	ConfidentialityModes	QualificationDirective 3-372
14	FacilitiesDirective 6-116, 6-117, 6-118, 6-121	VP-FA
15	FeatureActivity 5-154	CallingFeaturesIndicator
16	FlashRequest 6-138	VPM
17	HandoffBack 6-143, 6-145, 6-146	VPMASK , 2-6, 2-17, 2-31, 3-27, 3-28, 3-33,
18	HandoffToThird 6-155, 6-157, 6-158, 6-161,	3-71, 5-322
19	6-162	VRU
20	InterSystemSetup 6-185, 6-186	
21	Voice Privacy (VP) procedures	
22	Voice Privacy Capable	W
23	SystemCapabilities	
24	Voice Privacy Mode 1-23	Wait for Notification 6-281
25	Voice Response Unit 1-23	SMSDeliveryPointToPoint 6-282
26	VoiceMailboxNumber 1-23, 5-126, , 6-391, 6-	SMSNotification 6-286
27	392, 6-397	Wait for TLDN Call , 6-428
28	LocalTermination 5-208	incoming call attempt 6-25
29	MSC Routing Points of Return 6-21	InterSystemPage 6-178
30	RoutingRequest 6-258	RoutingRequest 6-259
31	RoutingRequest INVOKE 5-99	UnsolicitedResponse 6-305
32	VoiceMailboxPIN 5-126, , 6-389, 6-390, 6-	Waitable
33	391, 6-392, 6-393	ConditionallyDeniedReason
34	LocalTermination 5-208	Waitable MS Detected GSL
35	MSC Routing Points of Return 6-21	WarningTone
36	RoutingRequest 6-258	AnnouncementCode, Tone
37	RoutingRequest INVOKE 5-99	Weak Signal
38	VoiceMailRetrieval	HandoffReason
39	MSC Routing Points of Return 6-21	Weeks
40	VoiceMailStorage	AuthorizationPeriod
41	MSC Routing Points of Return 6-21	DeniedAuthorizationPeriod
42	VoicePrivacyMask 1-23, 5-45, 5-56, 5-64, 5-120,	Wide
43		NAMPSChannelData
44	AuthenticationRequest RETURN RESULT 5-	World Zone
45	35	OriginationTriggers
46	FacilitiesDirective INVOKE 5-42	SPINITriggers
47	FacilitiesDirective2 INVOKE 5-44	WZ
48	HandoffBack INVOKE 5-53	OriginationTriggers
49	HandoffBack2 INVOKE 5-55	SPINITriggers
50		
51		
52		
53		
54		
55		
56		
57		
58		
59		
60		

X

X.209 5-329, 5-330
XXXX

Y

Z

(This page intentionally left
blank.)

1
2
3
4
5
6
7
8
9
10
11
12
13
14
15
16
17
18
19
20
21
22
23
24
25
26
27
28
29
30
31
32
33
34
35
36
37
38
39
40
41
42
43
44
45
46
47
48
49
50
51
52
53
54
55
56
57
58
59
60

CELLULAR RADIOTELECOMMUNICATIONS INTERSYSTEM OPERATIONS:
CHAPTER 2
INTERSYSTEM HANDOFF INFORMATION FLOWS

1
2
3
4
5
6
7
8
9
10
11
12
13
14
15
16
17
18
19
20
21
22
23
24
25
26
27
28
29
30
31
32
33
34
35
36
37
38
39
40
41
42
43
44
45
46
47
48
49
50
51
52
53
54
55
56
57
58
59
60

CONTENTS

- LIST OF FIGURES..... iii
- LIST OF TABLESiv
- FOREWORD v
- REVISION HISTORY vi
- 1. INTRODUCTION 1
 - 1.1 OBJECTIVE..... 1
 - 1.2 SCOPE 1
 - 1.3 ORGANIZATION 2
- 2. REFERENCES..... 2
- 3. TERMINOLOGY 2
 - 3.1. DEFINITIONS 2
 - 3.2. SYMBOLS AND ABBREVIATIONS 2
 - 3.3. DOCUMENTATION CONVENTIONS 3
- 4. INTERSYSTEM HANDOFF OPERATIONS 3
 - 4.1. FacilitiesDirective 4
 - 4.1.1. Successful FacilitiesDirective 5
 - 4.1.2. Unsuccessful FacilitiesDirective 8
 - 4.2. FacilitiesDirective2 9
 - 4.2.1. Successful FacilitiesDirective2 10
 - 4.2.2. Unsuccessful FacilitiesDirective2 13
 - 4.3. FacilitiesRelease 14
 - 4.3.1. Successful FacilitiesRelease 14
 - 4.4. HandoffBack 16
 - 4.4.1. Successful HandoffBack 16
 - 4.4.2. Unsuccessful HandoffBack 19
 - 4.5. HandoffBack2 20
 - 4.5.1. Successful HandoffBack2 20
 - 4.5.2. Unsuccessful HandoffBack2 24
 - 4.6. HandoffMeasurementRequest 25
 - 4.6.1. Successful HandoffMeasurementRequest 25

		1
		2
4.7.	HandoffMeasurementRequest2.....	27
4.7.1.	Successful HandoffMeasurementRequest2.....	27
4.8.	HandoffToThird.....	30
4.8.1.	Successful HandoffToThird.....	30
4.8.2.	Unsuccessful HandoffToThird.....	33
4.9.	HandoffToThird2.....	34
4.9.1.	Successful HandoffToThird2.....	34
4.9.2.	Unsuccessful HandoffToThird2.....	38
4.10	InterSystemAnswer.....	39
4.10.1.	Successful InterSystemAnswer Following the Handoff of an Originating MS Awaiting Answer.....	39
4.10.2.	Successful InterSystemAnswer Following the Handoff of a Terminating MS in the Alerting State.....	40
4.11	Mobile On Channel.....	41
5.	BASIC INTERSYSTEM HANDOFF SCENARIOS.....	42
5.1.	Successful Handoff-Forward.....	43
5.2.	Successful Handoff-Back.....	45
5.3.	Successful Handoff-Forward with Tandem.....	47
5.4.	Successful Handoff-Back with Tandem.....	48
5.5.	Successful Handoff-To-Third with Path Minimization.....	49
5.6.	Successful Handoff-To-Third with Tandem and Path Minimization.....	51
5.7.	Successful Call Release by Served MS.....	53
5.8.	Successful Call Release by Other Party.....	55
5.9.	Successful Handoff-Forward of an Originating MS Awaiting Answer.....	57
5.10.	Successful Handoff-Forward of a Terminating MS While Alerting.....	59
	Annex A (normative): Additional DMH Support for Intersystem Handoff in TIA/EIA-41.....	61
		37
		38
		39
		40
		41
		42
		43
		44
		45
		46
		47
		48
		49
		50
		51
		52
		53
		54
		55
		56
		57
		58
		59
		60

LIST OF FIGURES

Figure 1	Successful FacilitiesDirective	5
Figure 2	Unsuccessful FacilitiesDirective	8
Figure 3	Successful FacilitiesDirective2	10
Figure 4	Unsuccessful FacilitiesDirective2	13
Figure 5	Successful FacilitiesRelease.....	14
Figure 6	Successful HandoffBack	16
Figure 7	Unsuccessful HandoffBack	19
Figure 8	Successful HandoffBack2	20
Figure 9	Unsuccessful HandoffBack2	24
Figure 10	Successful HandoffMeasurementRequest	25
Figure 11	Successful HandoffMeasurementRequest2	27
Figure 12	Successful HandoffToThird	30
Figure 13	Unsuccessful HandoffToThird	33
Figure 14	Successful HandoffToThird2	34
Figure 15	Unsuccessful HandoffToThird2	38
Figure 16	Successful InterSystemAnswer Following the Handoff of an Originating MS Awaiting Answer	39
Figure 17	Successful InterSystemAnswer Following the Handoff of a Terminating MS in the Alerting State	40
Figure 18	Successful Handoff-Forward.....	43
Figure 19	Successful Handoff-Back.....	45
Figure 20	Successful Handoff-Forward with Tandem	47
Figure 21	Successful Handoff-Back with Tandem.....	48
Figure 22	Successful Handoff-To-Third with Path Minimization.....	49
Figure 23	Successful Handoff-To-Third with Tandem and Path Minimization.....	51
Figure 24	Successful Call Release by Served MS.....	53
Figure 25	Successful Call Release by Other Party.....	55
Figure 26	Successful Handoff-Forward of an Originating MS Awaiting Answer	57
Figure 27	Successful Handoff-Forward of a Terminating MS While Alerting.....	59
Figure A.1	Handoff-Forward (A to B)	62
Figure A.2	Handoff-Back (B to A)	63
Figure A.3	Handoff-Forward (B to C)	64
Figure A.4	Handoff-Back (C to B)	65
Figure A.5	Path Minimization (A-B to A-C).....	66
Figure A.6	Release by the MS (C-B-A).....	67
Figure A.7	Release by the other party (A-B-C)	68
Figure A.8	Release Glare	69

LIST OF TABLES

Table 1	Operation Component and Timer Acronyms	3
Table 2	FE Combinations for FACDIR.....	4
Table 3	FE Combinations for FACDIR2.....	9
Table 4	FE Combinations for FACREL.....	14
Table 5	FE Combinations for HANDBACK	16
Table 6	FE Combinations for HANDBACK2	20
Table 7	FE Combinations for HANDMREQ.....	25
Table 8	FE Combinations for HANDMREQ2.....	27
Table 9	FE Combinations for HANDTHIRD	30
Table 10	FE Combinations for HANDTHIRD2	34
Table 11	FE Combinations for ISANSWER	39

1
2
3
4
5
6
7
8
9
10
11
12
13
14
15
16
17
18
19
20
21
22
23
24
25
26
27
28
29
30
31
32
33
34
35
36
37
38
39
40
41
42
43
44
45
46
47
48
49
50
51
52
53
54
55
56
57
58
59
60

FOREWORD

This Foreword is not part of this Standard.

This is one of a series of recommendations entitled:

“CELLULAR RADIOTELECOMMUNICATIONS INTERSYSTEM OPERATIONS”

which describe procedures necessary to provide to cellular radio telephone subscribers certain services requiring interaction between different cellular systems.

It is the intention of TIA/EIA TR-45.2 Subcommittee, Cellular System Operations, that this series of recommendations address the ongoing and developing concerns of the Cellular Radiotelecommunications Industry -- subscribers, service providers, and manufacturers alike -- with regard to useful and effective services requiring standardized intersystem procedures.

The recommendations included in this series are:

- Chapter 1, *Cellular Radiotelecommunications Intersystem Operations: Functional Overview*
- Chapter 2, *Cellular Radiotelecommunications Intersystem Operations: Intersystem Handoff Information Flows*
- Chapter 3, *Cellular Radiotelecommunications Intersystem Operations: Automatic Roaming Information Flows*
- Chapter 4, *Cellular Radiotelecommunications Intersystem Operations: Operations, Administration, and Maintenance Information Flows and Procedures*
- Chapter 5, *Cellular Radiotelecommunications Intersystem Operations: Signaling Protocols*
- Chapter 6, *Cellular Radiotelecommunications Intersystem Operations: Signaling Procedures*

This edition of the Standard replaces *IS-41-C* which differs from the previous edition (i.e., *IS-41-B*) in its support of the following functionality:

- Intersystem Authentication and Encryption (supersedes *TSB51*)
- Intersystem Operations for Dual-mode CDMA Terminals (supersedes *TSB64*)
- Border Cell Problem Resolution (supersedes *TSB65*)
- Expanded Feature Support (i.e., for features defined in *TIA/EIA-664*)
- Technical Clarifications and Compatibility (as per *TSB41* and *TSB55*)

REVISION HISTORY

Revision	Date	Remarks
<i>(IS-41) 0</i>	February 1988	Initial publication
<i>(IA-41) A</i>	January 1991	
<i>(IS-41) B</i>	December 1991	
<i>(IS-41) C</i>	February 1996	
D	December 1997	Initial ANSI publication

NOTE

The numbering system of this series of Standards varies from normal TIA/EIA practice. The unique numbering system assigned to these documents is intended to reflect their hierarchical structure.

1. INTRODUCTION

1.1 OBJECTIVE

This document presents the recommendation for the handoff sequence between two different Mobile Switching Centers (MSCs). This is often called *intersystem handoff*. To perform an intersystem handoff means to switch a Mobile Station (MS) telephone call that is in progress on one MSC, to a different MSC. In other words, an MS is assigned to a voice/traffic channel that is controlled by a different MSC.

During an MS telephone call, the MSC that is the first to assign a traffic channel to a call on origination or termination is called the *Anchor MSC*. For the duration of this call, this MSC shall be the anchor (i.e., fixed) point in the event that the MS should be handed off to other MSCs. The MSC controlling the call is termed the *Serving MSC*. A neighbor MSC is called a *Candidate MSC* if the neighbor is being considered as a possible server in a locate/handoff sequence. A neighbor MSC is called a *Target MSC* if the neighbor has been chosen by the Serving MSC as the next Serving MSC, but the handoff has not yet occurred. A Serving MSC which has previously received a handoff can initiate another handoff using the procedures appropriate to a Serving MSC, and thereby becomes a *Tandem MSC*.

Intersystem handoff is used when two MSCs are adjacent to one another and the neighbor system is better able to serve an MS than the serving system. The neighbor system and the serving system must have contiguous serving areas. It is assumed that MSCs may have information concerning their neighboring MSCs' capabilities that may effect how handoffs are performed and whether or not handoffs are performed. Intersystem handoff is triggered by the locate operation or mobile assisted handoff (MAHO). In the serving system, the neighbor system shall appear as a "neighbor" to the serving system cell sites that are adjacent to the neighbor system.

1.2 SCOPE

This document defines intersystem handoff by describing the information flows between functional entities which occur in a number of intersystem handoff scenarios.

Rather than taking an abstract approach, this document uses the information flows captured in the messages, parameters, and procedures defined in *IS-41-B* as its starting point. Additional information flows are specified in order to meet the requirements associated with the support of the features in *TIA/EIA-664*.

The detailed encoding of the signaling messages and parameters which are derived from the information flows in this document are specified in *TIA/EIA-41* Chapter 5.

The detailed definition of the functional entity procedures associated with the information flows in this document are specified in *TIA/EIA-41* Chapter 6.

Note that this document does not describe the algorithm or the data communication used internally by a system for an intersystem handoff.

1.3 ORGANIZATION

This document is organized as follows:

- Section 1, entitled “Introduction,” provides introductory information for this Standard.
- Section 2, entitled “References,” lists the normative and informative references for this Standard.
- Section 3, entitled “Terminology,” lists the definitions, symbols, abbreviations, and other documentation conventions used in this Standard.
- Section 4, entitled “Intersystem Handoff Operations,” defines the set of *TIA/EIA-41* intersystem handoff operations in terms of the interactions between network Functional Entities (FEs) involved in the support of the operations’ capabilities.
- Section 5, entitled “Basic Intersystem Handoff Scenarios,” depicts the interactions between FEs in various situations related to the support of basic intersystem handoff functionality (i.e., handoff-forward, handoff-back, handoff-to-third, handoff with tandems, and handoff with path minimization).

2. REFERENCES

Refer to Chapter 1.

3. TERMINOLOGY

3.1. DEFINITIONS

Refer to Chapter 1.

3.2. SYMBOLS AND ABBREVIATIONS

Refer to Chapter 1.

Throughout this Standard, the operation component acronyms listed in the following table are used. The acronyms for the operation timers (i.e., the timer that runs between the sending of an operation INVOKE component and the receipt of the operation response) are also listed.

Table 1 Operation Component and Timer Acronyms

Operation Name	INVOKE Component Acronym	RETURN RESULT Component Acronym	Operation Timer Acronym
FacilitiesDirective	FACDIR	facdir	HOT
FacilitiesDirective2	FACDIR2	facdir2	HOT
FacilitiesRelease	FACREL	facrel	CTT
HandoffBack	HANDBACK	handback	HOT
HandoffBack2	HANDBACK2	handback2	HOT
HandoffMeasurementRequest	HANDMREQ	handmreq	LMMRT
HandoffMeasurementRequest2	HANDMREQ2	handmreq2	LMMRT
HandoffToThird	HANDTHIRD	handthird	HTTT
HandoffToThird2	HANDTHIRD2	handthird2	HTTT
InterSystemAnswer	ISANSWER	isanswer	ISAT
MobileOnChannel	MSONCH	none	none

3.3. DOCUMENTATION CONVENTIONS

Refer to Chapter 1.

4. INTERSYSTEM HANDOFF OPERATIONS

This section defines the *TIA/EIA-41* intersystem handoff operations in terms of the interactions between network functional entities (FEs) involved in the support of the operations' capabilities. Refer to Section 3.2 for a listing of the operation component acronyms used in this section.

The operation usage scenarios shown throughout this section are for illustrative purposes only.

4.1. FacilitiesDirective and MobileOnChannel

The FacilitiesDirective (FACDIR) operation is used by the Anchor MSC, the Serving MSC or a Tandem MSC to request that the Target MSC initiate the Handoff-Forward task.

The MobileOnChannel operation is then used by the Target MSC to inform the requesting system that the Target MSC has successfully completed the Handoff-Forward task.¹

The following table lists the possible combinations of invoking and responding FEs.

Table 2FE Combinations for FACDIR

	INVOKING FE	RESPONDING FE
Case 1	Anchor MSC	Target MSC
Case 2	Serving MSC	Target MSC
Case 3	Tandem MSC	Target MSC

One of two possible results is returned:

1. Notification that the request was accepted, including the parameters of the voice channel selected by the Target MSC on the designated cell.
2. Notification that the request was unsuccessful because a voice channel on the designated cell is not available.

¹The MobileOnChannel operation is included here because it completes the transaction initiated with the FacilitiesDirective operation.

4.1.1. Successful FacilitiesDirective

This scenario describes the successful use of the FacilitiesDirective operation.

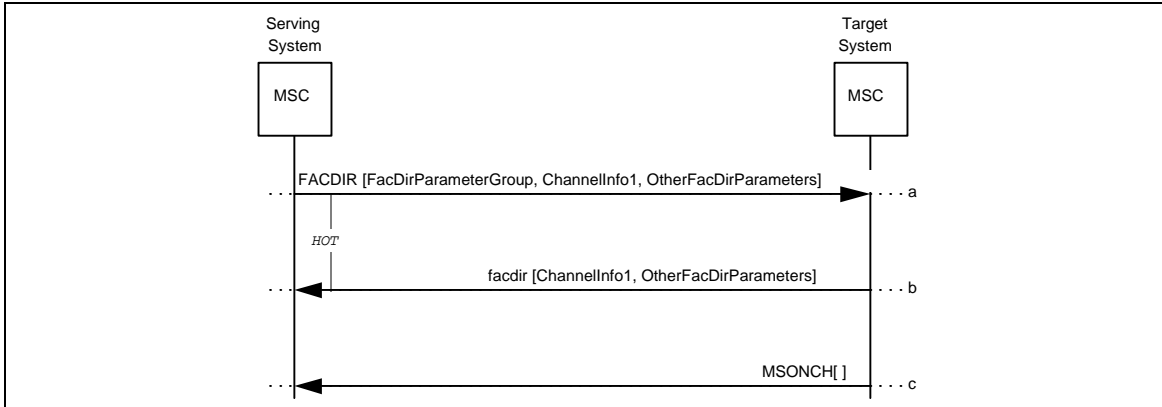

Figure 1 Successful FacilitiesDirective

- a. The Serving MSC determines that a call should be handed off to a target system. It sends a FACDIR to the Target MSC, directing the Target MSC to initiate a Handoff-Forward task.

Parameters	Usage	Type
FacDirParameterGroup:	Set of parameters in FACDIR, i.e.:	
[StationClassMark]	Indicates the power class and station type of the subscriber unit.	R
[MIN]	Served MS MIN.	R
[ESN]	Served MS ESN.	R
[TargetCellID]	Specifies the ID of the target cell site to be used in this transaction.	R
[BillingID]	Call ID. Used for billing and to identify the Anchor MSC.	R
[InterMSCCircuitID]	Specifies a trunk in a dedicated trunk group between the two MSCs to be used for handoff.	R
[ServingCellID]	Specifies the ID of the serving cell site to be used in this transaction.	R
[InterSwitchCount]	Indicates the number of inter-MSC facilities that will be transited by the call (including the Anchor MSC) at the successful conclusion of a pending handoff.	R

continued on next page...

...continued from previous page

Parameters	Usage	Type
[TDMACallMode]	Indicates the preferred mode of the current call.	O
[ConfidentialityModes]	Identifies the status of Signaling Message Encryption and Voice Privacy features for the MS and the subscriber's preference. Included if the MS is Signaling Message Encryption or Voice Privacy capable for this call.	O
[SMEKEY]	Contains the 64-bit Signaling Message Encryption Key. Included if the MS is capable of Signaling Message Encryption for this call.	O
[VPMASK]	Contains the two 260-bit masks used for voice privacy on a digital traffic channel. Included if available, if the MS supports TDMA, and if the MS is authorized for voice privacy.	O
[HandoffReason]	Reason for handoff = {Unspecified WeakSignal OffLoading Anticipatory}.	O
[HandoffState]	Indicates that the call is in the awaiting answer or alerting state.	O
ChannelInfo1:	Data identifying the serving channel, i.e.:	
[ChannelData]	Indicates the SAT Color Code, Voice Mobile Attenuation Code, and the channel number of the serving channel, if analog.	MBC ²
[TDMAChannelData]	Indicates the Rate, Digital Verification Color Code, Digital Mobile Attenuation Code, and the channel number of the serving channel, if TDMA.	O
OtherFacDirParameters:	Set of parameters in FACDIR:	
[TDMABurstIndicator]	Indicates whether or not the MS is required to transmit shortened burst (as defined in TDMA) after handoff. Included if a TDMA channel is in use.	O

²This parameter is mandatory in *IS-41-B*. It has zero length if the serving channel is not analog.

1
2
3
4
5
6
7
8
9
10
11
12
13
14
15
16
17
18
19
20
21
22
23
24
25
26
27
28
29
30
31
32
33
34
35
36
37
38
39
40
41
42
43
44
45
46
47
48
49
50
51
52
53
54
55
56
57
58
59
60

- b. If a voice channel on the designated target cell is available, the Target MSC increases the Segment Counter in the received BillingID parameter by one and uses the new BillingID for the new call segment. It then returns a *facdir* to the requesting MSC, and initiates a Handoff-Forward task.

Parameters	Usage	Type
ChannelInfo1: [ChannelData]	Data identifying the target channel, i.e.: Indicates the SAT Color Code, Voice Mobile Attenuation Code, and the channel number of the target channel, if analog.	MBC ³
[TDMAChannelData]	Indicates the Rate, Digital Verification Color Code, Digital Mobile Attenuation Code, and the channel number of the target channel, if TDMA.	O
OtherFacDirParameters: [ConfidentialityModes]	Set of parameters in <i>facdir</i> : Identifies the status of Signaling Message Encryption and Voice Privacy features for the MS actually used for call. Included if the TerminalType value is '2' or greater.	O
[TDMABurstIndicator]	Indicates whether or not the MS is required to transmit shortened burst (as defined in <i>TDMA</i>) after handoff. Included if a TDMA channel is in use.	O

- c. After having initiated the Handoff-Forward task, if the MS is received on the designated voice channel, the Target MSC completes the voice path between the voice channel and the inter-MSC trunk and then sends a MSONCH to the initiator of the Handoff-Forward task (the Serving MSC in this scenario).

4.1.2. Unsuccessful FacilitiesDirective

This scenario describes an unsuccessful invocation of the FacilitiesDirective operation.

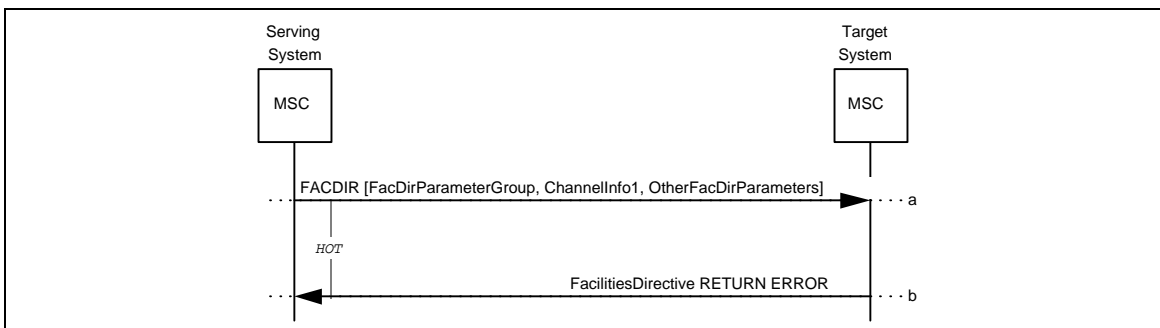

Figure 2 Unsuccessful FacilitiesDirective

- a. Same as Section 4.1.1, Step-a.

³This parameter is mandatory in *IS-41-B*. It has zero length if the serving channel is not analog.

- b. If a voice channel on the designated target cell is not available, the Target MSC returns a FacilitiesDirective RETURN ERROR component to the requesting MSC, indicating *ResourceShortage*.

1
2
3
4
5
6
7
8
9
10
11
12
13
14
15
16
17
18
19
20
21
22
23
24
25
26
27
28
29
30
31
32
33
34
35
36
37
38
39
40
41
42
43
44
45
46
47
48
49
50
51
52
53
54
55
56
57
58
59
60

4.2. FacilitiesDirective2 and MobileOnChannel

The FacilitiesDirective2 (FACDIR2) operation is used by the Anchor MSC, the Serving MSC or a Tandem MSC to request that the Target MSC initiate the Handoff-Forward task. This operation differs from the FacilitiesDirective operation in its addition of support for CDMA and NAMPS MSs.

The MobileOnChannel operation is then used by the Target MSC to inform the requesting system that the Target MSC has successfully completed the Handoff-Forward task.¹

The following table lists the possible combinations of invoking and responding FEs.

Table 3 FE Combinations for FACDIR2

	INVOKING FE	RESPONDING FE
Case 1	Anchor MSC	Target MSC
Case 2	Serving MSC	Target MSC
Case 3	Tandem MSC	Target MSC

One of two possible results is returned:

1. Notification that the request was accepted, including the parameters of the voice channel selected by the Target MSC on the designated cell.
2. Notification that the request was unsuccessful because a voice channel on the designated cell is not available.

¹The MobileOnChannel operation is included here because it completes the transaction initiated with the FacilitiesDirective2 operation.

1
2
3
4
5
6
7
8
9
10
11
12
13
14
15
16
17
18
19
20
21
22
23
24
25
26
27
28
29
30
31
32
33
34
35
36
37
38
39
40
41
42
43
44
45
46
47
48
49
50
51
52
53
54
55
56
57
58
59
60

4.2.1. Successful FacilitiesDirective2

This scenario describes the successful use of the FacilitiesDirective2 operation.

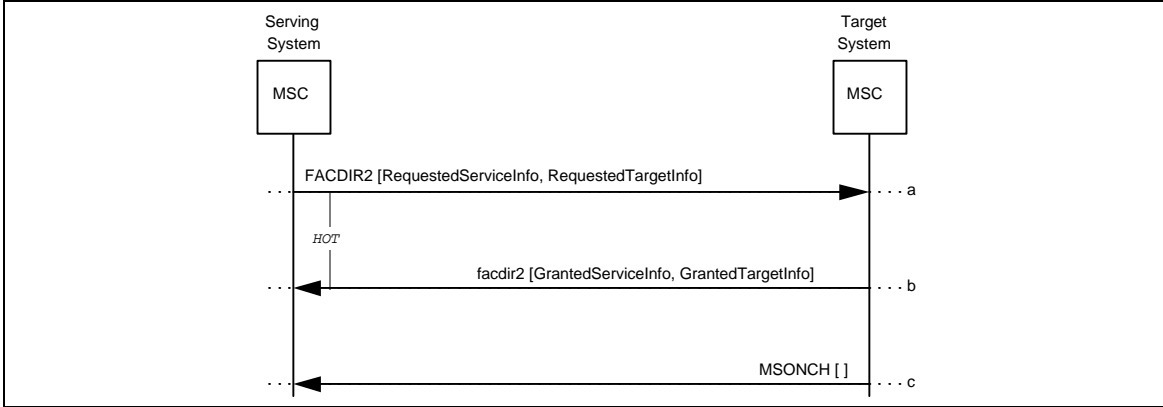

Figure 3 Successful FacilitiesDirective2

- a. The Serving MSC determines that a call should be handed off to a target system. It sends a FACDIR2 to the Target MSC, directing the Target MSC to initiate a Handoff-Forward task.

Parameters are as in Section 4.1.1, Step-a, with the exception that ChannelInfo1 is not included and with the following additions:

Parameters	Usage	Type
RequestedServiceInfo	Set of parameters for Requested Service Information	
[CDMACallMode]	Indicates the acceptable mode of the current call = {AMPS NAMPS CDMA}.	O
[CDMAChannelData]	Indicates the CDMA Channel Number field, the Frame Offset field and a Long Code Mask field of the serving channel, if CDMA.	O
[CDMAStationClass-Mark]	Identifies certain characteristics of a dual-mode CDMA MS.	O

continued on next page...

...continued from previous page

Parameters	Usage	Type
[CDMAMobile-ProtocolRevision]	Contains the Wideband Mobile Protocol Revision number of the MS, if available.	O
[CDMAPrivateLong-CodeMask]	Contains the 42-bit CDMA private long code mask. Included if available, if the MS supports CDMA, and if the MS is authorized for voice privacy.	O
[CDMAServingOneWay-Delay]	Estimated one-way delay from the MS to the serving cell site. Included if available.	O
[ChannelData]	Indicates the SAT Color Code, Voice Mobile Attenuation Code, and the channel number of the serving channel, if analog.	O
[MSLocation]	Provides the estimated location (latitude, longitude) of the MS with corresponding resolution. Included if available.	O
[NAMPSCallMode]	Indicates the acceptable mode of the current call = {AMPS NAMPS}.	O
[NAMPSChannelData]	Indicates the Digital SAT Color Code and the narrow voice channel assignment associated with the serving analog channel, if NAMPS.	O
[TDMABurstIndicator]	Indicates whether or not the MS is required to transmit shortened burst (as defined in <i>TDMA</i>) after handoff. Included if a TDMA channel is in use.	O
[TDMACallMode]	Indicates the acceptable mode of the current call = {AMPS TDMA}.	O
[TDMAChannelData]	Indicates the Rate, Digital Verification Color Code, Digital Mobile Attenuation Code, and the channel number of the serving channel, if TDMA.	O
RequestedTargetInfo:	Set of parameters for Requested Target Information. Only one of the following may be used: CDMATargetMAHOListCDMATargetMeasurementList or TargetCellID.	
[CDMATarget-MAHOList]	Include for CDMA MAHO case.	O
[CDMATarget-MeasurementList]	Include for CDMA non-MAHO case.	O
[TargetCellID]	Specifies the ID of the actual target cell site selected (AMPS, NAMPS, TDMA).	O

1
2
3
4
5
6
7
8
9
10
11
12
13
14
15
16
17
18
19
20
21
22
23
24
25
26
27
28
29
30
31
32
33
34
35
36
37
38
39
40
41
42
43
44
45
46
47
48
49
50
51
52
53
54
55
56
57
58
59
60

- b. If a voice channel on the designated target cell is available, the Target MSC increases the Segment Counter in the received BillingID parameter by one and uses the new BillingID for the new call segment. It then returns a facdir2 to the requesting MSC, and initiates a Handoff-Forward task.

Parameters	Usage	Type
GrantedServiceInfo:	Set of parameters for Granted Service Information.	
[CDMACodeChannel-List]	Identifies the code channels in a Forward CDMA Channel used for the call. Included if target channel is CDMA.	O
[CDMASearchWindow]	Specifies the number of PN chips that a CDMA MS should use to search for usable multipath components of the pilots in the Active Set and the Candidate Set. Included if target channel is CDMA.	O
[ConfidentialityModes]	Identifies the status of Signaling Message Encryption and Voice Privacy features for the MS actually used for call. Included if the TerminalType value is '2' or greater.	O
[TDMABurstIndicator]	Indicates whether or not the MS is required to transmit shortened burst (as defined in TDMA) after handoff. Included if a TDMA channel is in use.	O
GrantedTargetInfo:	Set of parameters for Target Service Information.	
[CDMAChannelData]	Indicates the CDMA Channel Number field, the Frame Offset field and a Long Code Mask field of the target channel, if CDMA.	O
[ChannelData]	Indicates the SAT Color Code, Voice Mobile Attenuation Code, and the channel number of the target channel, if analog.	O
[NAMPSChannelData]	Indicates the Digital SAT Color Code and the narrow voice channel assignment associated with the target analog channel, if NAMPS.	O
[TDMACHannelData]	Indicates the Rate, Digital Verification Color Code, Digital Mobile Attenuation Code, and the channel number of the target channel, if TDMA.	O
[TargetCellID]	Specifies the ID of the actual target cell site selected (AMPS, NAMPS, TDMA).	O

- c. After having initiated the Handoff-Forward task, if the MS is received on the designated voice channel, the Target MSC completes the voice path between the voice channel and the inter-MSC trunk and then sends a MSONCH to the initiator of the Handoff-Forward task (the Serving MSC in this scenario).

4.2.2. Unsuccessful FacilitiesDirective2

This scenario describes an unsuccessful invocation of the FacilitiesDirective2 operation.

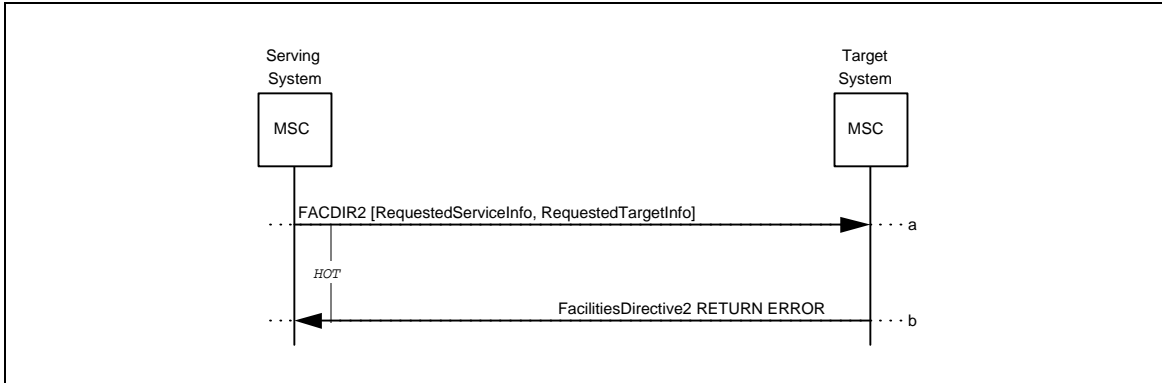

Figure 4 Unsuccessful FacilitiesDirective2

- a. Same as Section 4.2.1, Step-a.
- b. If a voice channel on the designated target cell is not available, the Target MSC returns a FacilitiesDirective2 RETURN ERROR component to the requesting MSC, indicating *ResourceShortage*.

1
2
3
4
5
6
7
8
9
10
11
12
13
14
15
16
17
18
19
20
21
22
23
24
25
26
27
28
29
30
31
32
33
34
35
36
37
38
39
40
41
42
43
44
45
46
47
48
49
50
51
52
53
54
55
56
57
58
59
60

4.3. FacilitiesRelease

The FacilitiesRelease (FACREL) operation is used to request that allocated resources for a call segment be released.

The following table lists the possible combinations of invoking and responding FEs.

Table 4 FE Combinations for FACREL

	INVOKING FE	RESPONDING FE
Case 1	MSC (Serving, Target, Anchor, or Tandem)	MSC (Serving, Target, Anchor, or Tandem)

4.3.1. Successful FacilitiesRelease

This scenario describes the normal use of the FacilitiesRelease operation.

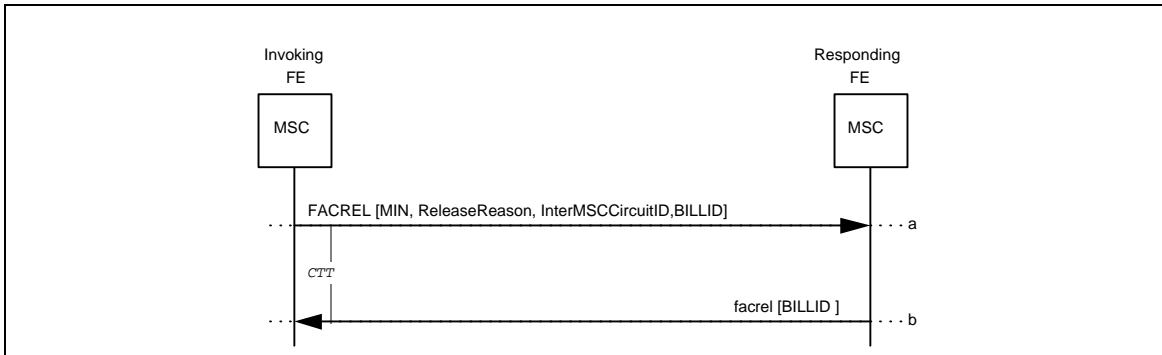

Figure 5 Successful FacilitiesRelease

- a. When an MSC determines that an inter-MSC trunk should be released it sends a FACREL to the receiving MSC.

Parameters	Usage	Type
MIN	MIN associated with specified trunk. Include if required by interconnection agreement.	O
ReleaseReason	Reason for requesting release.	R
InterMSCCircuitID	Specifies the trunk in a dedicated trunk group between the two MSCs to be released.	R
BILLID	Required for recording purposes (<i>DMH</i>) by the Responding FE and to report the number of call segments.	O

1
2
3
4
5
6
7
8
9
10
11
12
13
14
15
16
17
18
19
20
21
22
23
24
25
26
27
28
29
30
31
32
33
34
35
36
37
38
39
40
41
42
43
44
45
46
47
48
49
50
51
52
53
54
55
56
57
58
59
60

- b. On receipt of the FACREL, the receiving MSC marks the inter-MSC trunk as idle and returns a facrel.

Parameters	Usage	Type
BILLID	Required for recording purposes (<i>DMH</i>) by the Invoking FE and to report the number of call segments.	O

1
2
3
4
5
6
7
8
9
10
11
12
13
14
15
16
17
18
19
20
21
22
23
24
25
26
27
28
29
30
31
32
33
34
35
36
37
38
39
40
41
42
43
44
45
46
47
48
49
50
51
52
53
54
55
56
57
58
59
60

4.4. HandoffBack

The HandoffBack (HANDBACK) operation is used by the Serving MSC to request that the Target MSC initiate the Handoff-Back task. This task is used to handoff a call to a Target MSC to which the Serving MSC is already connected, for the call in question, via an inter-MSC trunk.

The following table lists the possible combinations of invoking and responding FEs.

Table 5 FE Combinations for HANDBACK

	INVOKING FE	RESPONDING FE
Case 1	Serving MSC	Target MSC

One of two possible results is returned:

1. Notification that the request was accepted, including the parameters of the voice channel selected by the Target MSC on the designated cell.
2. Notification that the request was unsuccessful because a voice channel on the designated cell is not available.

4.4.1. Successful HandoffBack

This scenario describes the successful use of the HandoffBack operation.

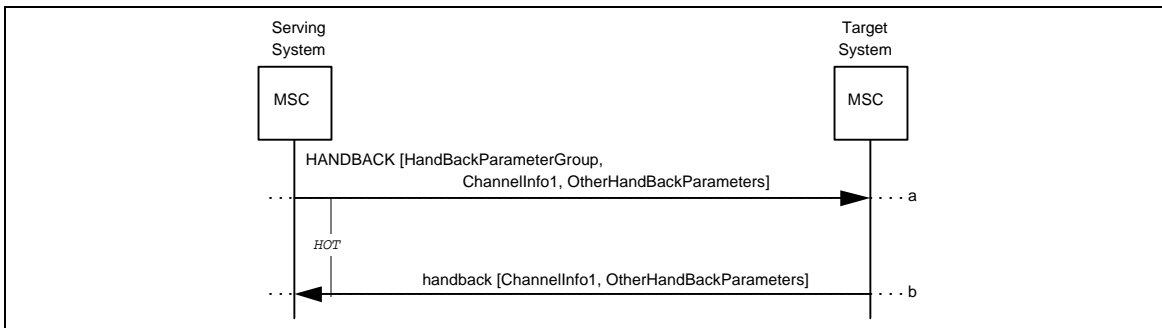

Figure 6 Successful HandoffBack

- a. The Serving MSC determines that a call should be handed off to a target system to which it is already connected, for the call in question, via an inter-MSC trunk. It sends a HANDBACK to the Target MSC, directing the Target MSC to initiate a Handoff-Back task.

Parameters	Usage	Type
HandBackParameterGroup:	Set of parameters in HANDBACK, i.e.:	
[MIN]	Served MS MIN.	R
[TargetCellID]	Specifies the ID of the target cell site to be used in this transaction.	R
[BillingID]	Call ID. Used for billing and to identify the Anchor MSC.	R
[InterMSCCircuitID]	Specifies a trunk in a dedicated trunk group between the two MSCs to be used for handoff (This trunk is released following the successful completion of a HANDBACK, See Section 5.2).	R
[ServingCellID]	Specifies the ID of the serving cell site to be used in this transaction.	R
[ConfidentialityModes]	Identifies the status of Signaling Message Encryption and Voice Privacy features for the MS and the subscriber's preference. Included if the TerminalType value is '2' or greater.	O
[SMEKEY]	Contains the 64-bit Signaling Message Encryption key. Included if the TerminalType value is '2' or greater.	O
[VPMASK]	Contains the two 260-bit masks used for voice privacy on a digital traffic channel. Included if available, if the MS supports TDMA, and if the MS is authorized for voice privacy.	O
[TDMACallMode]	Indicates the preferred mode of the current call.	O
[HandoffReason]	Reason for handoff = { Unspecified WeakSignal OffLoading Anticipatory }.	O
[HandoffState]	Indicates that the call is in the awaiting answer or alerting state.	O

continued on next page...

1
2
3
4
5
6
7
8
9
10
11
12
13
14
15
16
17
18
19
20
21
22
23
24
25
26
27
28
29
30
31
32
33
34
35
36
37
38
39
40
41
42
43
44
45
46
47
48
49
50
51
52
53
54
55
56
57
58
59
60

...continued from previous page

ChannelInfo1: [ChannelData]	Data identifying the serving channel, i.e.: Indicates the SAT Color Code, Voice Mobile Attenuation Code, and the channel number of the serving channel, if analog.	MBC ¹
[TDMACHannelData]	Indicates the Rate, Digital Verification Color Code, Digital Mobile Attenuation Code, and the channel number of the serving channel, if TDMA.	O
OtherHandBackParameters: [TDMABurstIndicator]	Set of parameters in handback: Indicates whether or not the MS is required to transmit shortened burst (as defined in <i>TDMA</i>) after handoff. Included if a TDMA channel is in use.	O

- b. The Target MSC increases the Segment Counter in the received BillingID parameter by one. If a voice channel on the designated target cell is available, it returns a handback to the requesting MSC, and initiates a Handoff-Back task.

Parameters	Usage	Type
ChannelInfo1: [ChannelData]	Data identifying the target channel, i.e.: Indicates the SAT Color Code, Voice Mobile Attenuation Code, and the channel number of the target channel, if analog.	MBC ¹
[TDMACHannelData]	Indicates the Rate, Digital Verification Color Code, Digital Mobile Attenuation Code, and the channel number of the target channel, if TDMA.	O
OtherHandBackParameters: [ConfidentialityModes]	Set of parameters in handback Identifies the status of Signaling Message Encryption and Voice Privacy features for the MS actually used for call. Included if the TerminalType value is '2' or greater.	O
[TDMABurstIndicator]	Indicates whether or not the MS is required to transmit shortened burst (as defined in <i>TDMA</i>) after handoff. Included if a TDMA channel is in use.	O

¹This parameter is mandatory in *IS-41-B*. It has zero length if the serving channel is not analog.

4.4.2. Unsuccessful HandoffBack

This scenario describes an unsuccessful invocation of the HandoffBack operation.

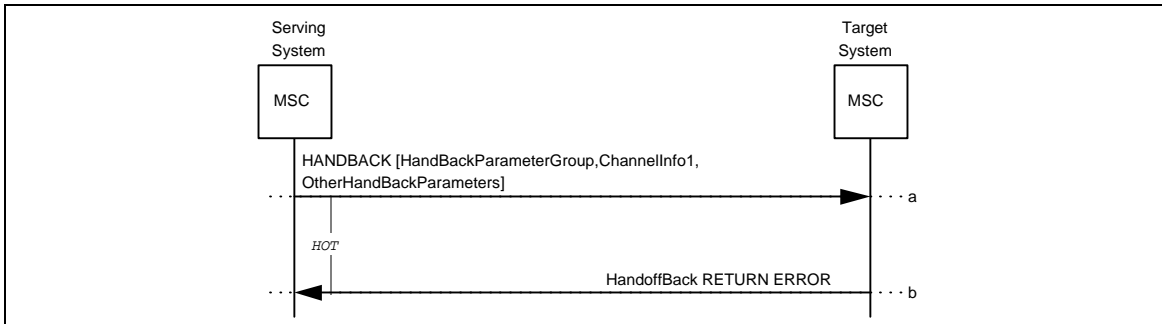

Figure 7 Unsuccessful HandoffBack

- a. Same as Section 4.4.1, Step-a.
- b. If a voice channel on the designated target cell is not available, the Target MSC returns a HandoffBack RETURN ERROR component to the requesting MSC, indicating *ResourceShortage*.

1
2
3
4
5
6
7
8
9
10
11
12
13
14
15
16
17
18
19
20
21
22
23
24
25
26
27
28
29
30
31
32
33
34
35
36
37
38
39
40
41
42
43
44
45
46
47
48
49
50
51
52
53
54
55
56
57
58
59
60

4.5. HandoffBack2

The HandoffBack2 (HANDBACK2) operation is used by the Serving MSC to request that the Target MSC initiate the Handoff-Back task. This task is used to handoff a call to a Target MSC to which the Serving MSC is already connected, for the call in question, via an inter-MSC trunk. This operation differs from the HandoffBack operation in its addition of support for CDMA MSs.

The following table lists the possible combinations of invoking and responding FEs.

Table 6 FE Combinations for HANDBACK2

	INVOKING FE	RESPONDING FE
Case 1	Serving MSC	Target MSC

4.5.1. Successful HandoffBack2

This scenario describes the successful use of the HandoffBack2 operation.

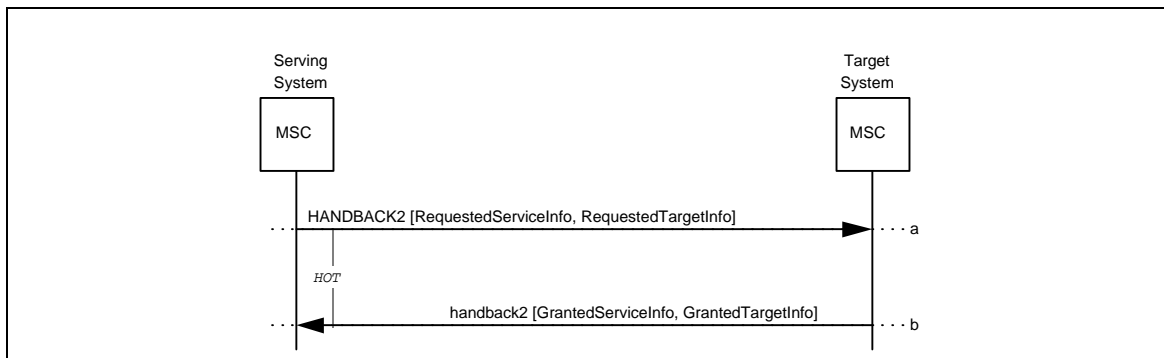

Figure 8 Successful HandoffBack2

- a. The Serving MSC determines that a call should be handed off to a target system to which it is already connected, for the call in question, via an inter-MSC trunk. It sends a HANDBACK2 to the Target MSC, directing the Target MSC to initiate a Handoff-Back task.

Parameters are as in Section 4.4.1, Step-a, with the exception that ChannelInfo1 is not included and with the following additions:		
Parameters	Usage	Type
RequestedServiceInfo	Set of parameters for Requested Service Information	
[CDMACallMode]	Indicates the preferred mode of the current call = {AMPS CDMA NAMPS}.	O
[CDMAChannelData]	Indicates the CDMA Channel Number field, the Frame Offset field and a Long Code Mask field of the serving channel, if CDMA.	O
[CDMAStationClass-Mark]	Identifies certain characteristics of a dual-mode CDMA MS.	O
[CDMAMobile-ProtocolRevision]	Contains the Wideband Mobile Protocol Revision number of the MS, if available.	O
[CDMAPrivateLong-CodeMask]	Contains the 42-bit CDMA private long code mask. Included if available, if the MS supports CDMA, and if the MS is authorized for voice privacy.	O
[CDMAServingOneWay-Delay]	Estimated one-way delay from the MS to the serving cell site. Included if available.	O
[ChannelData]	Indicates the SAT Color Code, Voice Mobile Attenuation Code, and the channel number of the serving channel, if analog.	O
[MSLocation]	Provides the estimated location (latitude, longitude) of the MS with corresponding resolution. Included if available.	O
[NAMPSCallMode]	Indicates the acceptable mode of the current call {AMPS NAMPS}.	O
[NAMPSChannelData]	Indicates the Digital SAT Color Code and the narrow voice channel assignment associated with the serving analog channel, if NAMPS.	O
[TDMACallMode]	Indicates the acceptable mode of the current call = {AMPS TDMA}.	O
[TDMABurstIndicator]	Indicates whether or not the MS is required to transmit shortened burst (as defined in <i>TDMA</i>) after handoff. Included if a TDMA channel is in use.	O
[TDMAChannelData]	Indicates the Rate, Digital Verification Color Code, Digital Mobile Attenuation Code, and the channel number of the serving channel, if TDMA.	O

continued on next page...

...continued from previous page

Parameters	Usage	Type
RequestedTargetInfo: [CDMATarget-MAHOList] [CDMATarget-MeasurementList] [TargetCellID]	Set of parameters for Requested Target Information. Only one of the following may be used: CDMATargetMAHOList, CDMATargetMeasurementList or TargetCellID. Include for CDMA MAHO case. Include for CDMA non-MAHO case. Specifies the ID of the actual target cell site selected (AMPS, NAMPS, TDMA).	 O O O

1
2
3
4
5
6
7
8
9
10
11
12
13
14
15
16
17
18
19
20
21
22
23
24
25
26
27
28
29
30
31
32
33
34
35
36
37
38
39
40
41
42
43
44
45
46
47
48
49
50
51
52
53
54
55
56
57
58
59
60

- b. The Target MSC increases the Segment Counter in the received BillingID parameter by one. If a voice channel on the designated target cell is available, it returns a handback2 to the requesting MSC, and initiates a Handoff-Back task.

Parameters	Usage	Type
GrantedServiceInfo	Set of parameters for Granted Service Information.	
[CDMACodeChannel-List]	Identifies the code channels in a Forward CDMA Channel used for the call. Included if target channel is CDMA.	O
[CDMASearchWindow]	Specifies the number of PN chips that a CDMA MS should use to search for usable multipath components of the pilots in the Active Set and the Candidate Set. Included if target channel is CDMA.	O
[ConfidentialityModes]	Identifies the status of Signaling Message Encryption and Voice Privacy features for the MS actually used for call. Included if the TerminalType value is '2' or greater.	O
[TDMABurstIndicator]	Indicates whether or not the mobile is required to transmit shortened burst (as defined in TDMA) after handoff. Included if a TDMA channel is in use.	O
GrantedTargetInfo:	Set of parameters for Target Service Information.	
[CDMAChannelData]	Indicates the CDMA Channel Number field, the Frame Offset field and a Long Code Mask field of the target channel, if CDMA.	O
[ChannelData]	Indicates the SAT Color Code, Voice Mobile Attenuation Code, and the channel number of the target channel, if analog.	O
[NAMPSChannelData]	Indicates the Digital SAT Color Code and the narrow voice channel assignment associated with the target analog channel, if NAMPS.	O
[TargetCellID]	Specifies the ID of the actual target cell site selected (AMPS, NAMPS, TDMA).	O
[TDMACHannelData]	Indicates the Rate, Digital Verification Color Code, Digital Mobile Attenuation Code, and the channel number of the target channel, if TDMA.	O

4.5.2. Unsuccessful HandoffBack2

This scenario describes an unsuccessful invocation of the HandoffBack2 operation.

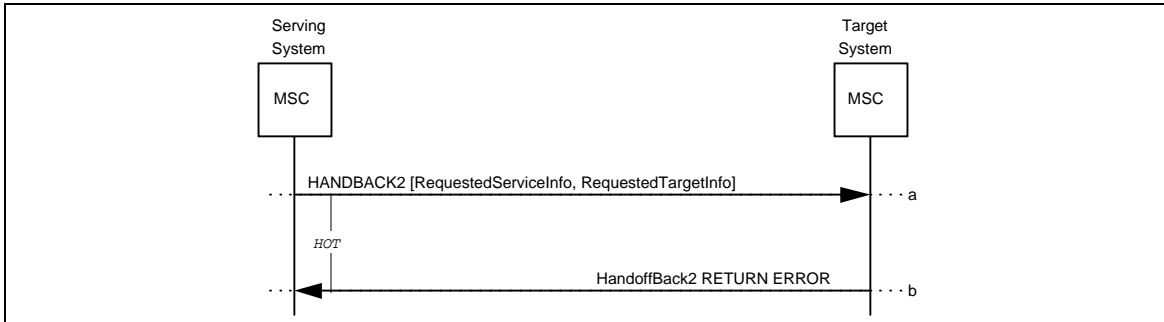

Figure 9 Unsuccessful HandoffBack2

- a. Same as Section 4.5.1, Step-a.
- b. If a voice channel on the designated target cell is not available, the Target MSC returns a HandoffBack2 RETURN ERROR component to the requesting MSC, indicating *ResourceShortage*.

1
2
3
4
5
6
7
8
9
10
11
12
13
14
15
16
17
18
19
20
21
22
23
24
25
26
27
28
29
30
31
32
33
34
35
36
37
38
39
40
41
42
43
44
45
46
47
48
49
50
51
52
53
54
55
56
57
58
59
60

4.6. HandoffMeasurementRequest

The HandoffMeasurementRequest (HANDMREQ) operation is sent by the Serving MSC to any adjacent MSCs to request a signal quality measurement on the specified channel.

The following table lists the possible combinations of invoking and responding FEs.

Table 7 FE Combinations for HANDMREQ

	INVOKING FE	RESPONDING FE
Case 1	Serving MSC	Adjacent MSC

This request should result in a response with one or more candidate cells.

4.6.1. Successful HandoffMeasurementRequest

This scenario describes the successful use of the HandoffMeasurementRequest operation where signal quality measurements are returned.

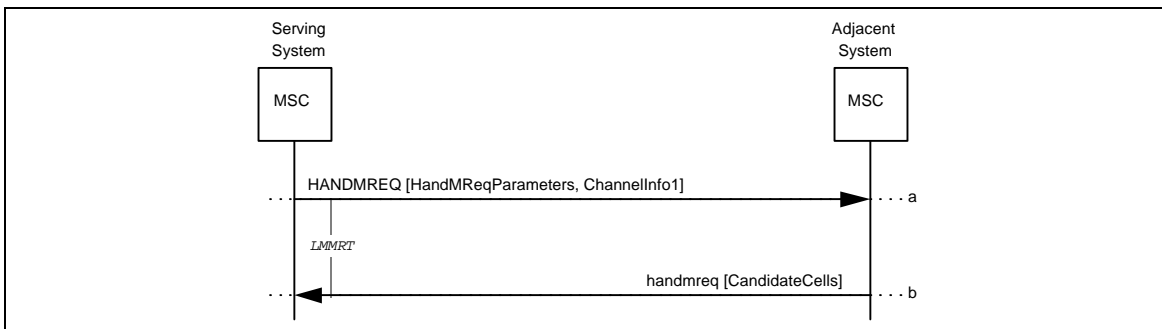

Figure 10 Successful HandoffMeasurementRequest

1
2
3
4
5
6
7
8
9
10
11
12
13
14
15
16
17
18
19
20
21
22
23
24
25
26
27
28
29
30
31
32
33
34
35
36
37
38
39
40
41
42
43
44
45
46
47
48
49
50
51
52
53
54
55
56
57
58
59
60

- a. The Serving MSC elects, based on its internal algorithm, to determine if a handoff to an adjacent candidate MSC is appropriate. The Serving MSC sends a HANDMREQ to the candidate MSC (the Serving MSC may send several handoff measurement requests to different candidate MSCs).

Parameters	Usage	Type
HandMReqParameters:	Set of parameters in HANDMREQ.	
[StationClassMark]	Indicates the power class and station type of the subscriber unit.	R
[ServingCellID]	Specifies the ID of the serving cell site to be used in this transaction.	R
[TDMACallMode]	Indicates the preferred mode of the current call.	O
ChannelInfo1:	Data identifying the serving channel.	
[ChannelData]	Indicates the SAT Color Code, Voice Mobile Attenuation Code, and the channel number of the serving channel, if analog.	MBC ¹
[TDMACHannelData]	Indicates the Rate, Digital Verification Color Code, Digital Mobile Attenuation Code, and the channel number of the serving channel, if TDMA.	O

- b. The candidate MSC identifies the candidate cell sites corresponding to the ServingCellID in the HANDMREQ. It performs location measurements in accordance with the MSC’s internal algorithm.

When all expected internal responses are received, if the best candidate cell site does not meet the quality criteria of the candidate MSC, the candidate MSC may elect to end the location process. In this case, no handmreq is returned.

Otherwise, the candidate MSC converts the location quality values to the appropriate “signal quality” parameter values with respect to the maximum power levels allowed in the candidate cell sites, the current MS power level in the serving cell site and station class mark.

The results are returned to the Serving MSC in a handmreq.

Parameters	Usage	Type
CandidateCells:	A list of one or more sets of the following two parameters identifying the candidate cells, i.e.:	
[TargetCellID]	Specifies the ID of the candidate cell site.	R
[SignalQuality]	Indicates the relative received signal strength of a MS for which a location process has been performed.	R

¹This parameter is mandatory in *IS-41-B*. It has zero length if the serving channel is not analog.

4.7. HandoffMeasurementRequest2

The HandoffMeasurementRequest2 (HANDMREQ2) operation is sent by the Serving MSC to any adjacent MSCs to request a signal quality measurement on the specified channel. This operation differs from the HandoffMeasurementRequest operation in its addition of support for CDMA MSs.

The following table lists the possible combinations of invoking and responding FEs.

Table 8 FE Combinations for HANDMREQ2

	INVOKING FE	RESPONDING FE
Case 1	Serving MSC	Adjacent MSC

4.7.1. Successful HandoffMeasurementRequest2

This scenario describes the successful use of the HandoffMeasurementRequest2 operation where signal quality measurements are returned.

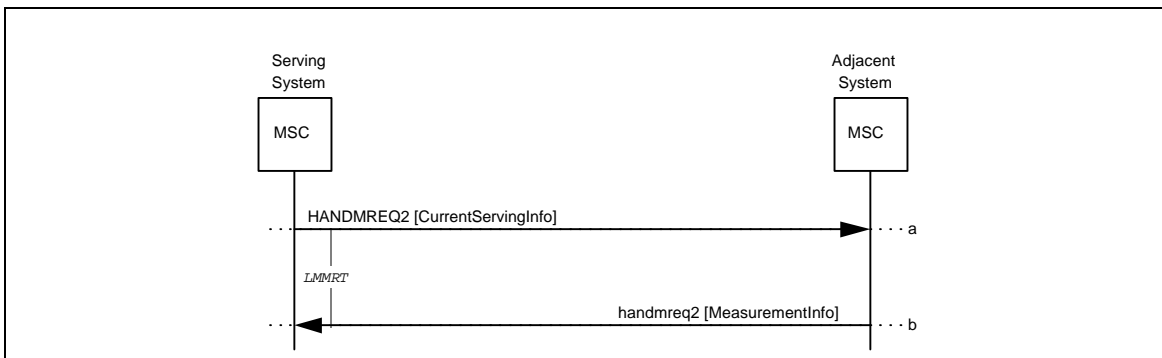

Figure 11 Successful HandoffMeasurementRequest2

1
2
3
4
5
6
7
8
9
10
11
12
13
14
15
16
17
18
19
20
21
22
23
24
25
26
27
28
29
30
31
32
33
34
35
36
37
38
39
40
41
42
43
44
45
46
47
48
49
50
51
52
53
54
55
56
57
58
59
60

- a. The Serving MSC elects, based on its internal algorithm, to determine if a handoff to an adjacent candidate MSC is appropriate. The Serving MSC sends a HANDMREQ2 to the candidate MSC (the Serving MSC may send several handoff measurement requests to different candidate MSCs).

Parameters are as in Section 4.6.1, Step-a, with the exception that ChannelInfo1 is not included and with the following additions:		
Parameters	Usage	Type
CurrentServingInfo:	Set of parameters for Current Serving Information	
[CDMACallMode]	Indicates the preferred mode of the current call = {AMPS CDMA NAMPS}.	O
[CDMAChannelData]	Indicates the CDMA Channel Number field, the Frame Offset field and a Long Code Mask field of the serving channel, if CDMA.	O
[CDMAStationClass-Mark]	Identifies certain characteristics of a dual-mode CDMA MS.	O
[CDMAServingOneWay-Delay]	Estimated one-way delay from the MS to the serving cell site. Included if available.	O
[ChannelData]	Indicates the SAT Color Code, Voice Mobile Attenuation Code, and the channel number of the serving channel, if analog.	O
[MSLocation]	Provides the estimated location (latitude, longitude) of the MS with corresponding resolution. Included if available.	O
[NAMPSCallMode]	Indicates the acceptable mode of the current call {AMPS NAMPS}.	O
[NAMPSChannelData]	Indicates the Digital SAT Color Code and the narrow voice channel assignment associated with the serving analog channel, if NAMPS.	O
[TDMACallMode]	Indicates the acceptable mode of the current call = {AMPS TDMA}.	O
[TDMAChannelData]	Indicates the Rate, Digital Verification Color Code, Digital Mobile Attenuation Code, and the channel number of the serving channel, if TDMA.	O

- b. The candidate MSC identifies the candidate cell sites corresponding to the ServingCellID in the HANDMREQ2. It performs location measurements in accordance with the MSC's internal algorithm.

When all expected internal responses are received, if the best candidate cell site does not meet the quality criteria of the candidate MSC, the candidate MSC may elect to end the location process. In this case, no handmreq2 is returned.

1
2
3
4
5
6
7
8
9
10
11
12
13
14
15
16
17
18
19
20
21
22
23
24
25
26
27
28
29
30
31
32
33
34
35
36
37
38
39
40
41
42
43
44
45
46
47
48
49
50
51
52
53
54
55
56
57
58
59
60

Otherwise:

- For analog or TDMA traffic channels, the candidate MSC converts the location quality values to the appropriate “signal quality” parameter values with respect to the maximum power levels allowed in the candidate cell sites, the current MS power level in the serving cell site and station class mark.
- For CDMA traffic channels, the candidate MSC converts the location quality values to the CDMASignalQuality parameter value and includes the TargetOneWayDelay value, if available.

The results are returned to the Serving MSC in a handmreq2.

Parameters	Usage	Type
MeasurementInfo:	A list of parameters with Measurement Information	
[CDMATarget-MeasurementList]	Include for CDMA.	O
[TargetMeasurementList]	Include for AMPS, NAMPS or TDMA.	O

1
2
3
4
5
6
7
8
9
10
11
12
13
14
15
16
17
18
19
20
21
22
23
24
25
26
27
28
29
30
31
32
33
34
35
36
37
38
39
40
41
42
43
44
45
46
47
48
49
50
51
52
53
54
55
56
57
58
59
60

4.8. HandoffToThird

The HandoffToThird (HANDTHIRD) operation is used by the Serving MSC (non-Anchor) to initiate a handoff with path minimization.

The following table lists the possible combinations of invoking and responding FEs.

Table 9 FE Combinations for HANDTHIRD

	INVOKING FE	RESPONDING FE
Case 1	Serving MSC	Anchor MSC
Case 2	Serving MSC	Tandem MSC
Case 3	Tandem MSC	Tandem MSC

4.8.1. Successful HandoffToThird

This scenario describes the successful use of the HandoffToThird operation.

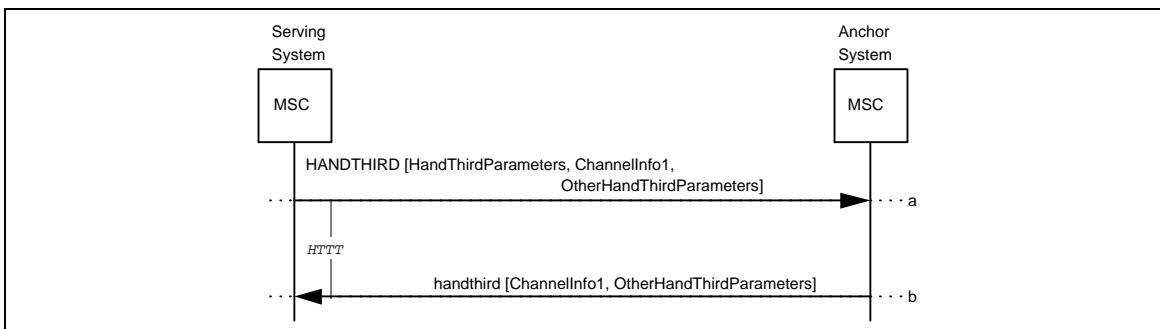

Figure 12 Successful HandoffToThird

- a. The Serving MSC determines that a call should be handed off to a target system and that path minimization may be possible. It sends a HANDTHIRD to the MSC which had previously handed off the call to the Serving MSC (i.e., the Anchor MSC in this scenario), requesting that a handoff with path minimization be performed.

Parameters	Usage	Type
HandThirdParameters:	Set of parameters in HANDTHIRD, i.e.:	
[StationClassMark]	Indicates the power class and station type of the subscriber unit.	R
[MIN]	Served MS MIN.	R
[ESN]	Served MS ESN.	R
[TargetCellID]	Specifies the ID of the target cell site to be used in this transaction.	R
[MSCID]	MSCID of Target MSC.	R
[BillingID]	Call ID. Used for billing and to identify the Anchor MSC.	R
[InterMSCCircuitID]	Specifies a trunk in a dedicated trunk group between the two MSCs to be used for handoff.	R
[ServingCellID]	Specifies the ID of the serving cell site to be used in this transaction.	R
[InterSwitchCount]	Indicates the number of inter-MSC facilities that will be transited by the call (including the Anchor MSC) at the successful conclusion of a pending handoff.	R
[ConfidentialityModes]	Identifies the status of Signaling Message Encryption and Voice Privacy features for the MS and the subscriber's preference. Included if the TerminalType value is '2' or greater.	O
[SMEKEY]	Contains the 64-bit signaling message encryption key. Included if the TerminalType value is '2' or greater.	O
[VPMASK]	Contains the two 260-bit masks used for voice privacy on a digital traffic channel. Included if available, if the MS supports TDMA, and if the MS is authorized for voice privacy.	O
[TDMACallMode]	Indicates the preferred mode of the current call.	O
[HandoffReason]	Reason for handoff = {Unspecified WeakSignal OffLoading Anticipatory}.	O

continued on next page...

...continued from previous page

Parameters	Usage	Type
ChannelInfo1: [ChannelData]	Data identifying the serving channel, i.e.: Indicates the SAT Color Code, Voice Mobile Attenuation Code, and the channel number of the serving channel, if analog.	MBC ¹
[TDMACHannelData]	Indicates the Rate, Digital Verification Color Code, Digital Mobile Attenuation Code, and the channel number of the serving channel, if TDMA.	O
OtherHandThirdParameters: [TDMABurstIndicator]	Set of parameters in <i>handthird</i> : Indicates whether or not the mobile is required to transmit shortened burst (as defined in <i>TDMA</i>) after handoff. Included if a TDMA channel is in use.	O

- b. If the receiving MSC accepts the request to perform a handoff with path minimization, and a voice channel on the target system is found available, the receiving MSC returns the parameters of the selected voice channel to the Serving MSC in a *handthird*.

Parameters	Usage	Type
ChannelInfo1: [ChannelData]	Data identifying the target channel, i.e.: Indicates the SAT Color Code, Voice Mobile Attenuation Code, and the channel number of the target channel, if analog.	O
[TDMACHannelData]	Indicates the Rate, Digital Verification Color Code, Digital Mobile Attenuation Code, and the channel number of the target channel, if TDMA.	O
OtherHandThirdParameters: [ConfidentialityModes]	Set of parameters in <i>handthird</i> : Identifies the status of Signaling Message Encryption and Voice Privacy features for the MS actually used for call. Included if the <i>TerminalType</i> value is '2' or greater.	O
[TDMABurstIndicator]	Indicates whether or not the mobile is required to transmit shortened burst (as defined in <i>TDMA</i>) after handoff. Included if a TDMA channel is in use.	O

¹This parameter is mandatory in *IS-41-B*. It has zero length if the serving channel is not analog.

1
2
3
4
5
6
7
8
9
10
11
12
13
14
15
16
17
18
19
20
21
22
23
24
25
26
27
28
29
30
31
32
33
34
35
36
37
38
39
40
41
42
43
44
45
46
47
48
49
50
51
52
53
54
55
56
57
58
59
60

1
2
3
4 **4.8.2. Unsuccessful HandoffToThird**

5
6 This scenario describes an unsuccessful invocation of the HandoffToThird operation.

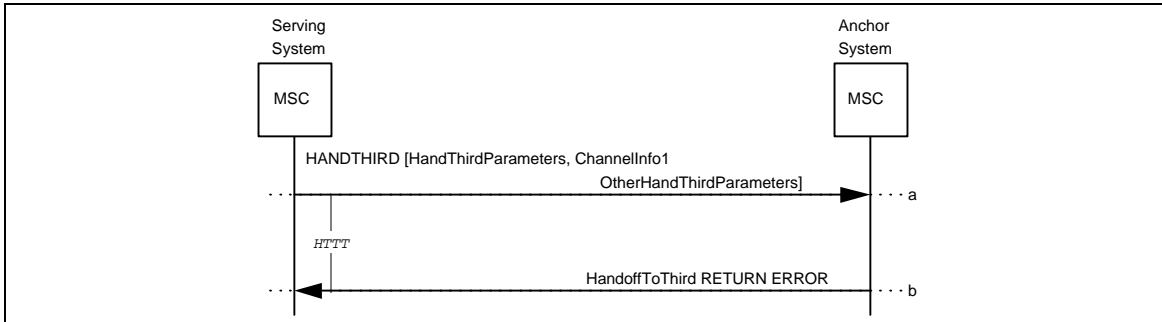

19 **Figure 13 Unsuccessful HandoffToThird**

- 20 a. Same as Section 4.8.1, Step-a.
21
22 b. If a voice channel on the designated target cell is not available, the Anchor MSC
23 returns a HandoffToThird RETURN ERROR component to the requesting MSC,
24 indicating *ResourceShortage*.
25
26
27
28
29
30
31
32
33
34
35
36
37
38
39
40
41
42
43
44
45
46
47
48
49
50
51
52
53
54
55
56
57
58
59
60

1
2
3
4
5
6
7
8
9
10
11
12
13
14
15
16
17
18
19
20
21
22
23
24
25
26
27
28
29
30
31
32
33
34
35
36
37
38
39
40
41
42
43
44
45
46
47
48
49
50
51
52
53
54
55
56
57
58
59
60

4.9. HandoffToThird2

The HandoffToThird2 (HANDTHIRD2) operation is used by the Serving MSC (non-Anchor) to initiate a handoff with path minimization. This operation differs from the HandoffToThird operation in its support of dual-mode CDMA MSs.

The following table lists the possible combinations of invoking and responding FEs.

Table 10 FE Combinations for HANDTHIRD2

	INVOKING FE	RESPONDING FE
Case 1	Serving MSC	Anchor MSC
Case 2	Serving MSC	Tandem MSC
Case 3	Tandem MSC	Tandem MSC

4.9.1. Successful HandoffToThird2

This scenario describes the successful use of the HandoffToThird2 operation.

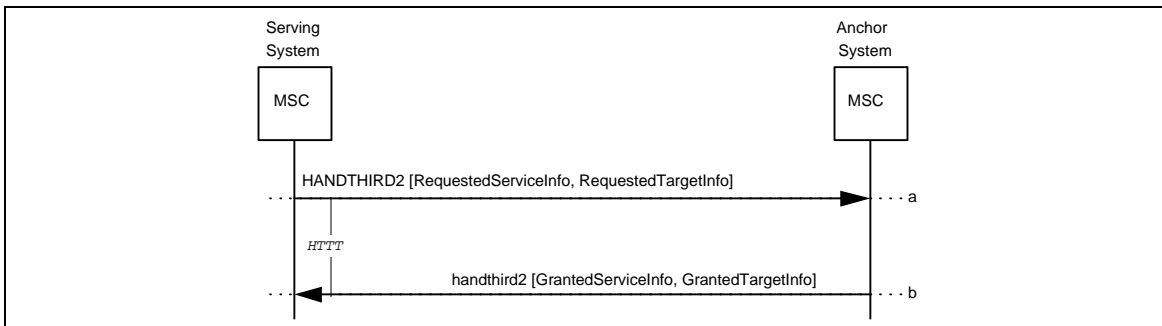

Figure 14 Successful HandoffToThird2

- a. The Serving MSC determines that a call should be handed off to a target system and that path minimization may be possible. It sends a `HANDTHIRD2` to the MSC which had previously handed off the call to the Serving MSC (i.e., the Anchor MSC in this scenario), requesting that a handoff with path minimization be performed.

Parameters are as in Section 4.8.1, Step-a, with the exception that ChannelInfo1 is not included and with the following additions:		
Parameters	Usage	Type
RequestedServiceInfo :	Set of parameters for Requested Service Information	
[CDMACallMode]	Indicates the preferred mode of the current call = {AMPS CDMA NAMPS}.	O
[CDMAChannelData]	Indicates the CDMA Channel Number field, the Frame Offset field and a Long Code Mask field of the serving channel, if CDMA.	O
[CDMAStationClass-Mark]	Identifies certain characteristics of a dual-mode CDMA MS.	O
[CDMAMobile-ProtocolRevision]	Contains the Wideband Mobile Protocol Revision number of the MS, if available.	O
[CDMAPrivateLong-CodeMask]	Contains the 42-bit CDMA private long code mask. Included if available, if the MS supports CDMA, and if the MS is authorized for voice privacy.	O
[CDMAServingOneWay-Delay]	Estimated one-way delay from the MS to the serving cell site. Included if available.	O
[ChannelData]	Indicates the SAT Color Code, Voice Mobile Attenuation Code, and the channel number of the serving channel, if analog.	O
[MSLocation]	Provides the estimated location (latitude, longitude) of the MS with corresponding resolution. Included if available.	O
[NAMPSCallMode]	Indicates the acceptable mode of the current call {AMPS NAMPS}.	O
[NAMPSChannelData]	Indicates the Digital SAT Color Code and the narrow voice channel assignment associated with the serving analog channel, if NAMPS.	O
[TDMABurstIndicator]	Indicates whether or not the MS is required to transmit shortened burst (as defined in <i>TDMA</i>) after handoff. Included if a TDMA channel is in use.	O
[TDMACallMode]	Indicates the acceptable mode of the current call = {AMPS TDMA}.	O
[TDMAChannelData]	Indicates the Rate, Digital Verification Color Code, Digital Mobile Attenuation Code, and the channel number of the serving channel, if TDMA.	O

continued on next page...

...continued from previous page

Parameters	Usage	Type
RequestedTargetInfo: [CDMATarget-MAHOList] [CDMATarget-MeasurementList] [TargetCellID]	Set of parameters for Requested Target Information. Only one of the following may be used: CDMATargetMAHOList, CDMATargetMeasurementList or TargetCellID. Include for CDMA MAHO case. Include for CDMA non-MAHO case. Specifies the ID of the actual target cell site selected (AMPS, NAMPS, TDMA).	 O O O

1
2
3
4
5
6
7
8
9
10
11
12
13
14
15
16
17
18
19
20
21
22
23
24
25
26
27
28
29
30
31
32
33
34
35
36
37
38
39
40
41
42
43
44
45
46
47
48
49
50
51
52
53
54
55
56
57
58
59
60

- b. If the receiving MSC accepts the request to perform a handoff with path minimization, and a voice channel on the target system is found available, the receiving MSC returns the parameters of the selected voice channel to the Serving MSC in a `handthird2`.

Parameters	Usage	Type
GrantedServiceInfo:	Set of parameters for Granted Service Information.	
[CDMACodeChannel-List]	Identifies the code channels in a Forward CDMA Channel used for the call. Included if target channel is CDMA.	O
[CDMASearchWindow]	Specifies the number of PN chips that a CDMA MS should use to search for usable multipath components of the pilots in the Active Set and the Candidate Set. Included if target channel is CDMA.	O
[ConfidentialityModes]	Identifies the status of Signaling Message Encryption and Voice Privacy features for the MS actually used for call. Included if the TerminalType value is '2' or greater.	O
[TDMABurstIndicator]	Indicates whether or not the MS is required to transmit shortened burst (as defined in <i>TDMA</i>) after handoff. Included if a TDMA channel is in use.	O
GrantedTargetInfo:	Set of parameters for Target Service Information.	
[CDMAChannelData]	Indicates the CDMA Channel Number field, the Frame Offset field and a Long Code Mask field of the target channel, if CDMA.	O
[ChannelData]	Indicates the SAT Color Code, Voice Mobile Attenuation Code, and the channel number of the target channel, if analog.	O
[NAMPSChannelData]	Indicates the Digital SAT Color Code and the narrow voice channel assignment associated with the target analog channel, if NAMPS.	O
[TDMACHannelData]	Indicates the Rate, Digital Verification Color Code, Digital Mobile Attenuation Code, and the channel number of the target channel, if TDMA.	O
[TargetCellID]	Specifies the ID of the actual target cell site selected (AMPS, NAMPS, TDMA).	O

4.9.2. Unsuccessful HandoffToThird2

This scenario describes an unsuccessful invocation of the HandoffToThird2 operation.

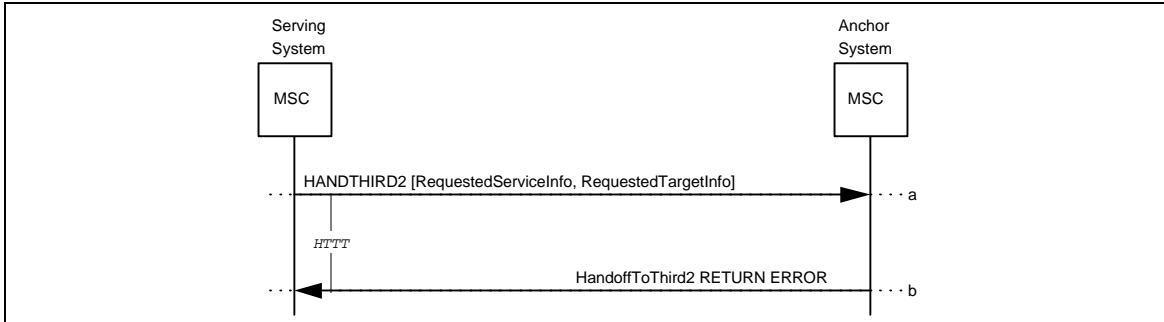

Figure 15 Unsuccessful HandoffToThird2

- a. Same as Section 4.9.1, Step-a.
- b. If a voice channel on the designated target cell is not available, the Anchor MSC returns a HandoffToThird2 RETURN ERROR component to the requesting MSC, indicating *ResourceShortage*.

1
2
3
4
5
6
7
8
9
10
11
12
13
14
15
16
17
18
19
20
21
22
23
24
25
26
27
28
29
30
31
32
33
34
35
36
37
38
39
40
41
42
43
44
45
46
47
48
49
50
51
52
53
54
55
56
57
58
59
60

4.10 InterSystemAnswer

The InterSystemAnswer (ISANSWER) operation is used by either an Anchor MSC or a Serving MSC following the handoff of an MS in the awaiting answer or alerting state.

The following table lists the valid combinations of invoking and responding FEs.

Table 11 FE Combinations for ISANSWER

	INVOKING FE	RESPONDING FE
Case 1	Anchor MSC	Serving MSC
Case 2	Serving MSC	Anchor MSC

4.10.1. Successful InterSystemAnswer Following the Handoff of an Originating MS Awaiting Answer

This scenario describes the successful use of the InterSystemAnswer operation.

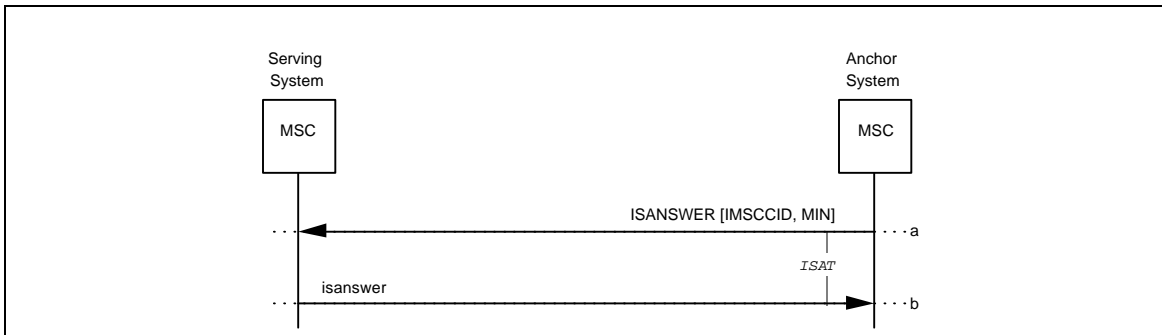

Figure 16 Successful InterSystemAnswer Following the Handoff of an Originating MS Awaiting Answer

- a. The Anchor MSC sends an ISANSWER to the serving MSC, indicating that the call has been answered.

Parameters	Usage	Type
IMSCCID	Specifies a trunk in a dedicated trunk group between the two MSCs	R
MIN	Served MS MIN.	R

- b. The Serving MSC acknowledges receipt of the ISANSWER by sending an empty isanswer to the Anchor MSC.

4.10.2. Successful InterSystemAnswer Following the Handoff of a Terminating MS in the Alerting State

This scenario describes the successful use of the InterSystemAnswer operation.

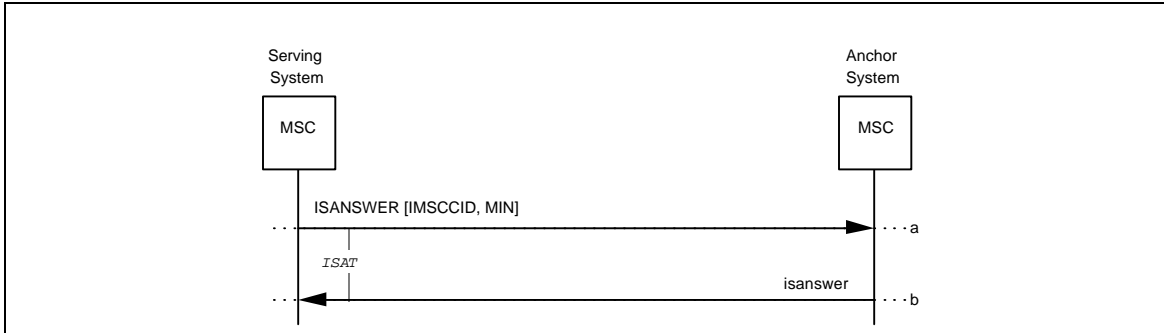

Figure 17 Successful InterSystemAnswer Following the Handoff of a Terminating MS in the Alerting State

- a. The Serving MSC sends an ISANSWER to the Anchor MSC indicating that the call has been answered.

Parameters	Usage	Type
IMSCCID	Specifies a trunk in a dedicated trunk group between the two MSCs	R
MIN	Served MS MIN.	R

- b. The Anchor MSC acknowledges receipt of the ISANSWER by sending an empty isanswer to the Serving MSC.

1
2
3
4
5
6
7
8
9
10
11
12
13
14
15
16
17
18
19
20
21
22
23
24
25
26
27
28
29
30
31
32
33
34
35
36
37
38
39
40
41
42
43
44
45
46
47
48
49
50
51
52
53
54
55
56
57
58
59
60

1
2
3
4
5
6
7
8
9
10
11
12
13
14
15
16
17
18
19
20
21
22
23
24
25
26
27
28
29
30
31
32
33
34
35
36
37
38
39
40
41
42
43
44
45
46
47
48
49
50
51
52
53
54
55
56
57
58
59
60

4.11 Mobile On Channel

Refer to FacilitiesDirective and FacilitiesDirective2 scenarios (see 4.1 and 4.2).

5. BASIC INTERSYSTEM HANDOFF SCENARIOS

This section depicts the interactions between network entities in various situations related to the support of basic intersystem handoff functionality, i.e.:

- *Handoff-Forward*. The handoff of a call from Serving MSC to Target MSC, where the Target MSC is not already on the call path (i.e., is not the Anchor or a tandem MSC) and path minimization is not applied.
- *Handoff-Back*. The handoff of a call from Serving MSC to Target MSC, where the Target MSC is already on the call path.
- *Handoff-Forward with Tandem*. The Handoff-Forward process when more than two MSCs are involved.
- *Handoff-Back with Tandem*. The Handoff-Back process when more than two MSCs are involved.
- *Handoff-To-Third with Path Minimization*. The handoff of a call from Serving MSC to Target MSC, where the Target MSC is not already on the call path (i.e., is not the Anchor or a tandem MSC) and path minimization is applied.
- *Handoff-To-Third with Tandem and Path Minimization*. The Handoff-To-Third with Path Minimization process when more than two MSCs are involved.
- *Call Release*. The release of a call that had previously been handed-off. This can be initiated by the served MS or the other party of the call.

The FacilitiesDirective, HandoffBack, HandoffMeasurementRequest, and HandoffToThird operations are used throughout this section; however, the FacilitiesDirective2, HandoffBack2, HandoffMeasurementRequest2, and HandoffToThird2 operations, respectively, may be substituted for these operations without impacting the scenarios as illustrated.

5.1. Successful Handoff-Forward

This scenario describes the successful Handoff-Forward process.

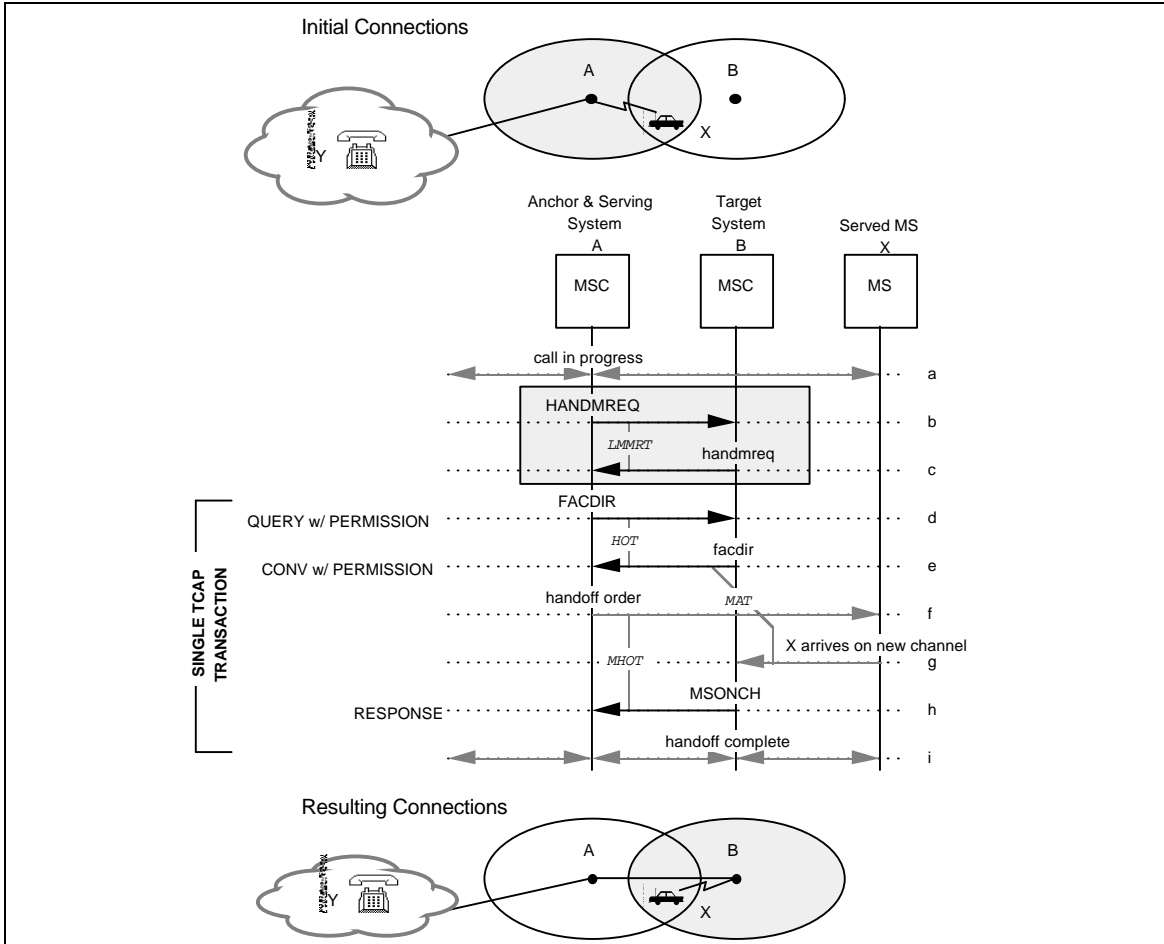

Figure 18 Successful Handoff-Forward

- a. A call involving the served MS is in progress.
- b. The Serving MSC elects, based on its internal algorithm, to determine if a handoff to an adjacent candidate MSC is appropriate. The Serving MSC may send a `HANDMREQ` to the candidate MSC (the Serving MSC may send several handoff measurement requests to different candidate MSCs).
- c. The candidate MSC performs location measurements in accordance with the MSC's internal algorithm and returns the results to the Serving MSC in a `handmreq`.
- d. The Serving MSC determines that the call should be handed off to the candidate (now Target) MSC and that the Target MSC is not already on the call path. It sends a `FACDIR` to the Target MSC, directing the Target MSC to initiate a Handoff-Forward task. If the Serving MSC counts tandem segments, then increment the Segment Counter by one in the `BillingID` parameter.
- e. A voice channel on the designated target cell is available; therefore, the Target MSC increases the Segment Counter in the received `BillingID` parameter by one and uses the new `BillingID` for the new call segment, returns a `facdir` to the requesting MSC, and initiates a Handoff-Forward task.
- f. On receipt of the `facdir`, the Serving MSC sends a Mobile Handoff Order to the served MS.
- g. The MS is received on the designated voice channel; therefore, ...
- h. ...the Target MSC completes the voice path between the voice channel and the inter-MSC trunk and sends a `MSONCH` to the initiator of the Handoff-Forward task, the Serving MSC, informing the requesting system that the Target MSC has successfully completed the Handoff-Forward task.
- i. The Serving MSC, on receipt of the `MSONCH`, completes the handoff process. The interMSC trunk should be connected at this time if it has not already been connected.

5.2. Successful Handoff-Back

This scenario describes the successful Handoff-Back process.

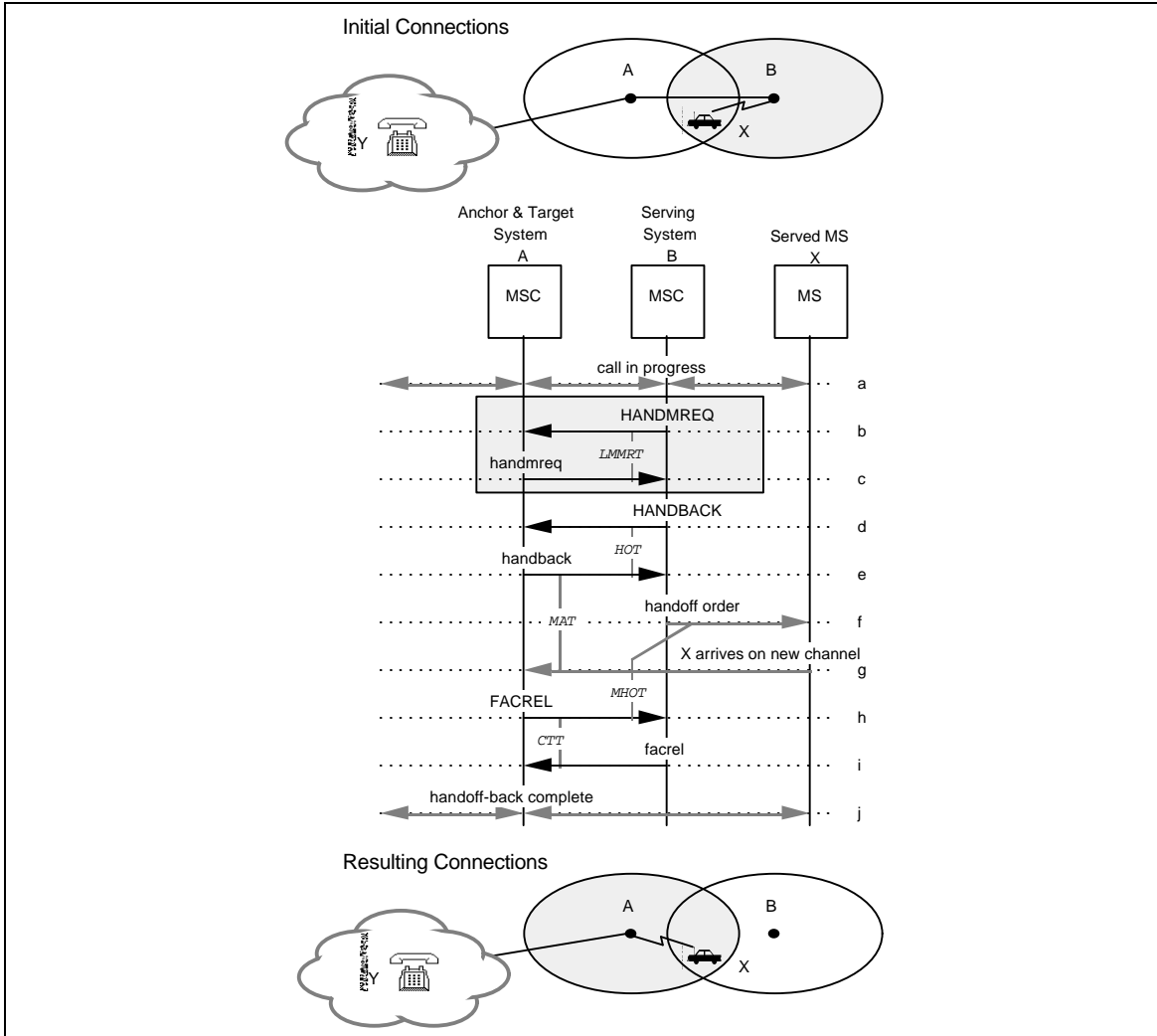

Figure 19 Successful Handoff-Back

- a-c. Same as Section 5.1, Steps a-c.
- d. The Serving MSC determines that the call should be handed off to the candidate (now Target) MSC and that the Target MSC is already on the call path. It sends a `HANDBACK` to the Target MSC, directing the Target MSC to initiate a Handoff-Back task.
- e. A voice channel on the designated target cell is available; therefore, the Target MSC increases the Segment Counter in the received `BillingID` parameter by one and uses the new `BillingID` for the new call segment, returns a `handback` to the requesting MSC, and initiates a Handoff-Back task.
- f. The Serving MSC, on receipt of the `handback`, sends a Handoff Order to the served MS.
- g. The MS is received on the designated voice channel; therefore, ...
- h. ...the Target MSC sends a `FACREL` to the Serving MSC, indicating *HandoffSuccessful*.
- i. The Serving MSC sends a `facrel` to the Target MSC and marks the inter-MSC trunk as idle.
- j. The Target MSC marks the inter-MSC trunk as idle and the handoff-back process is complete.

1
2
3
4
5
6
7
8
9
10
11
12
13
14
15
16
17
18
19
20
21
22
23
24
25
26
27
28
29
30
31
32
33
34
35
36
37
38
39
40
41
42
43
44
45
46
47
48
49
50
51
52
53
54
55
56
57
58
59
60

5.3. Successful Handoff-Forward with Tandem

This scenario describes the successful Handoff-Forward process when more than two MSCs are involved.

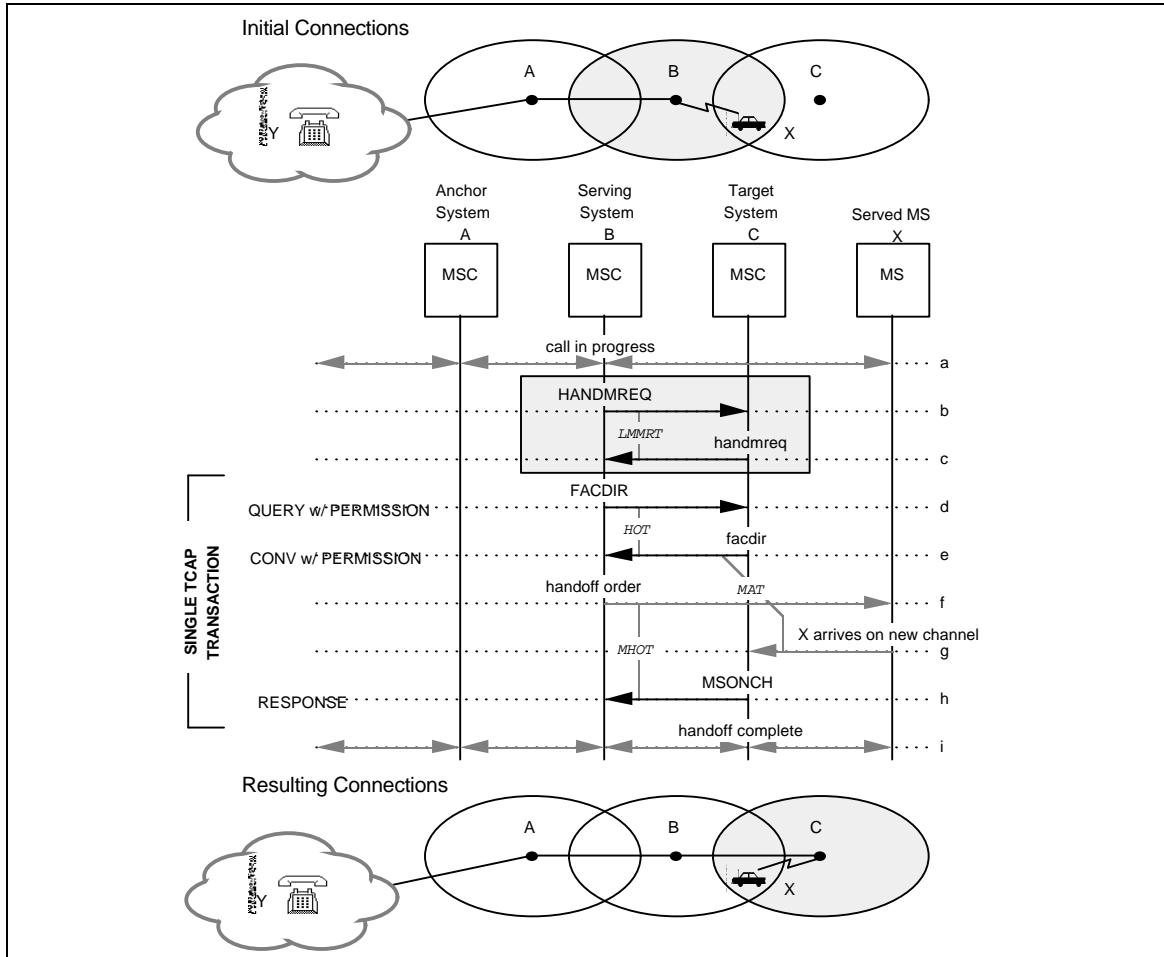

Figure 20 Successful Handoff-Forward with Tandem

a-i. Same as Section 5.1, Steps a-i.

5.4. Successful Handoff-Back with Tandem

This scenario describes the successful Handoff-Back process when more than two MSCs are involved.

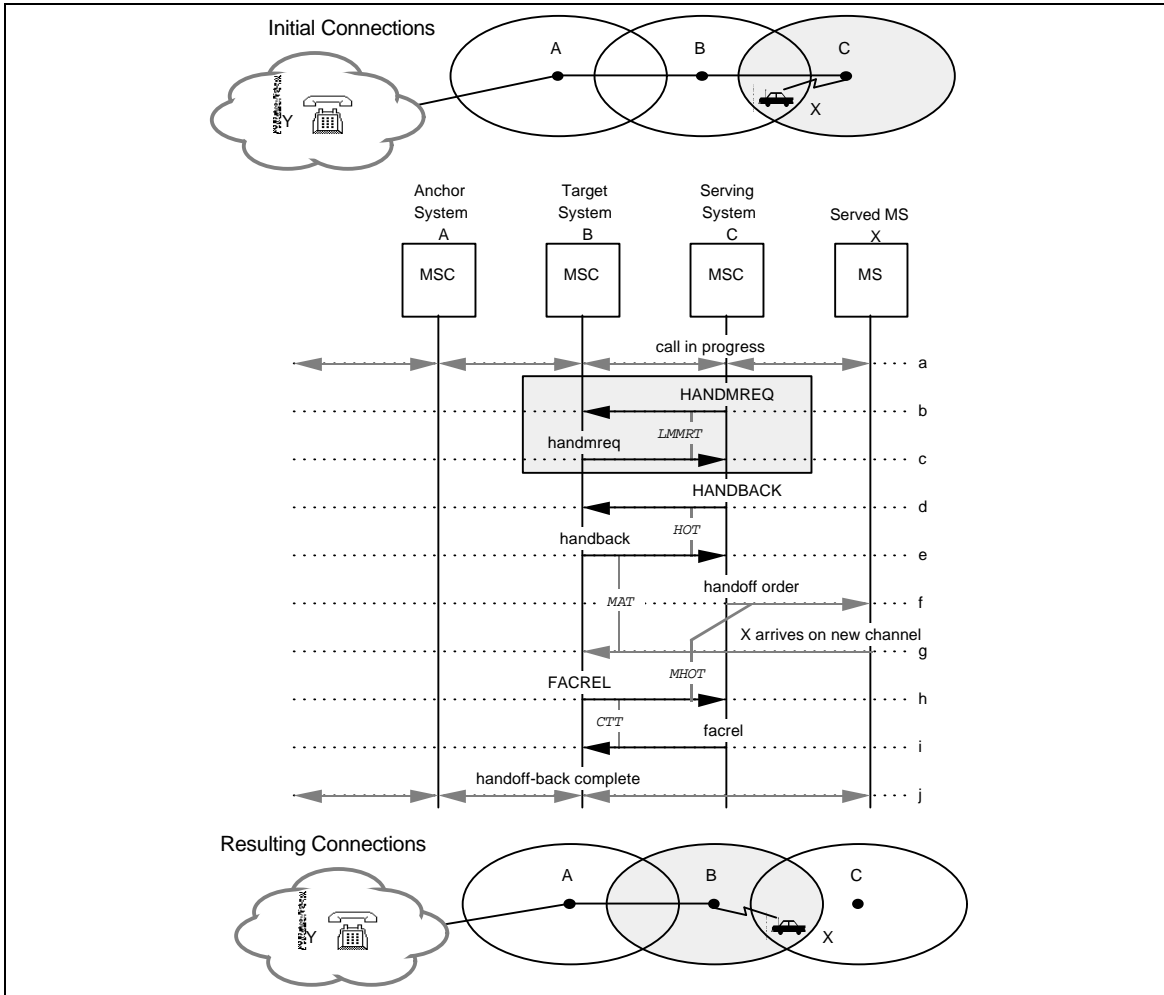

Figure 21 Successful Handoff-Back with Tandem

a-j. Same as Section 5.2, Steps a-j.

1
2
3
4
5
6
7
8
9
10
11
12
13
14
15
16
17
18
19
20
21
22
23
24
25
26
27
28
29
30
31
32
33
34
35
36
37
38
39
40
41
42
43
44
45
46
47
48
49
50
51
52
53
54
55
56
57
58
59
60

5.5. Successful Handoff-To-Third with Path Minimization

This scenario describes the successful Handoff-To-Third with Path Minimization process.

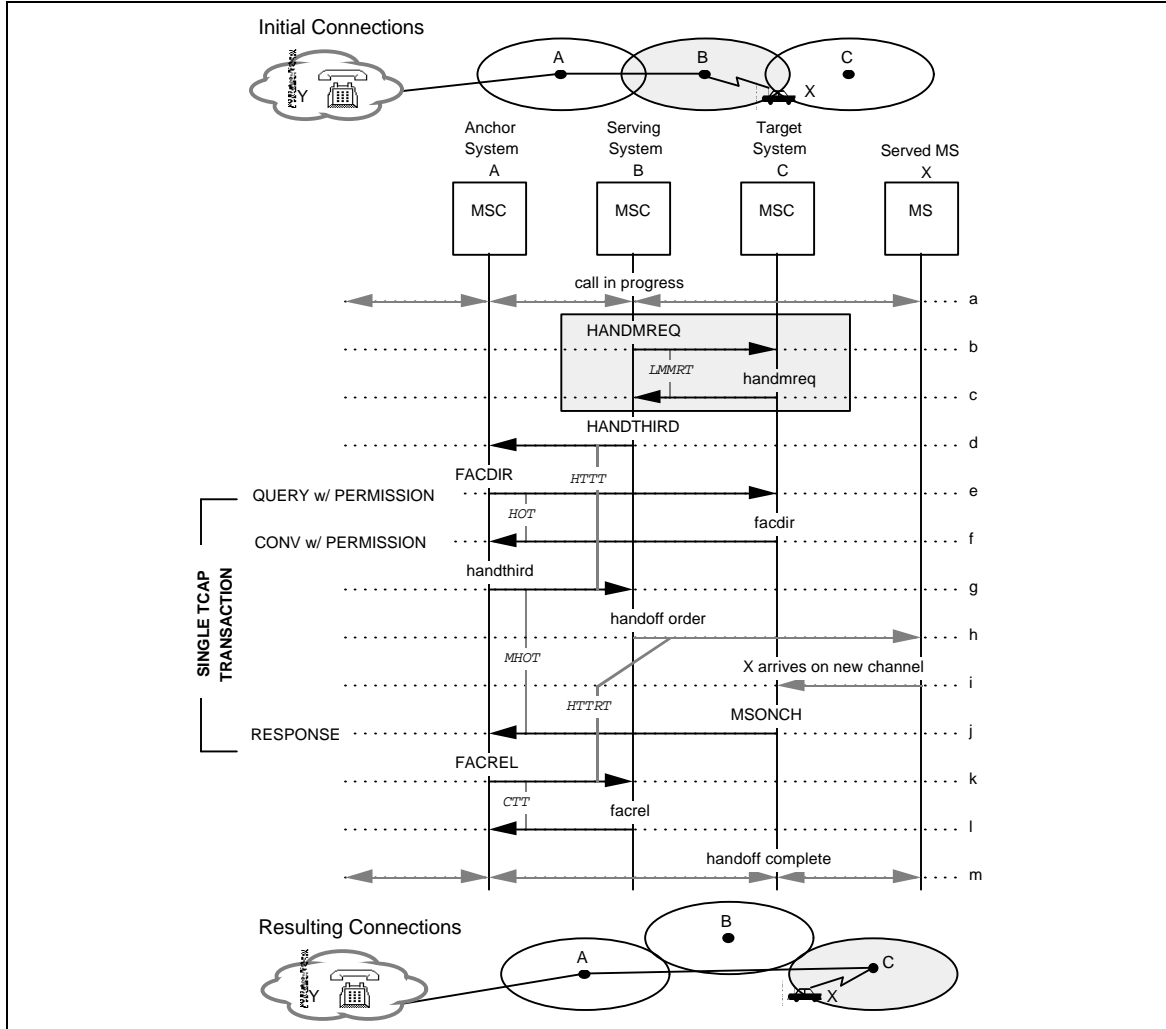

Figure 22 Successful Handoff-To-Third with Path Minimization

- a-c. Same as Section 5.1, Steps a-c.
- d. The Serving MSC determines that the call should be handed off to the target system and that path minimization may be possible. It sends a `HANDTHIRD` to the MSC which had previously handed off the call to the Serving MSC (i.e., the Anchor MSC), requesting that MSC to perform a handoff with path minimization. The current Segment Counter is sent in the `BillingID` parameter.
- e. The Target MSC is known to the Anchor MSC and an inter-MSC trunk is available; therefore, the Anchor MSC attempts to perform the handoff with path minimization. It sends a `FACDIR` to the Target MSC. If the Anchor MSC counts new tandem segment, then increment the Segment Counter by one in the received `BillingID` parameter.
- f. A voice channel on the designated target cell is available; therefore, the Target MSC increases the Segment Counter in the received `BillingID` parameter by one and uses the new `BillingID` for the new call segment, returns a `facdir` to the requesting MSC, and initiates a Handoff-Forward task.
- g. The Anchor MSC, having accepted the request to perform the handoff with path minimization and found a voice channel on the target system available, returns the parameters of the selected voice channel to the Serving MSC in a `handthird`.
- h. The Serving MSC, on receipt of the `handthird`, sends a Handoff Order to the served MS.
- i. The MS is received on the designated voice channel; therefore, the Target MSC completes the voice path between the voice channel and the inter-MSC trunk and...
- j. ... sends a `MSONCH` to the initiator of the Handoff-Forward task, the Anchor MSC, informing the requesting system that the Target MSC has successfully completed the Handoff-Forward task.
- k. The Anchor MSC connects the call path with the inter-MSC trunk to the Target MSC, and requests release of the inter-MSC trunk to the previous Serving MSC by sending a `FACREL`, with the reason for release indicating *HandoffSuccessful*.
- l. The previous Serving MSC marks the inter-MSC trunk as idle and returns a `facrel` to the Anchor MSC, which then also marks the inter-MSC trunk as idle.
- m. The handoff is now complete.

- a-c. Same as Section 5.1, Steps a-c.
- d. The Serving MSC determines that the call should be handed off to the target system and that path minimization may be possible. It sends a `HANDTHIRD` to the MSC which had previously handed off the call to the Serving MSC (i.e., the Tandem MSC), requesting that MSC to perform a handoff with path minimization.
- e. The Tandem MSC calculates the difference between the `InterSwitchCount` value received in the `HANDTHIRD` and the value stored in the MSC. The difference is not greater than `TANDEMDEPTH`¹; therefore, the Tandem MSC adjusts the relevant parameters in the `HANDTHIRD` and transmits the message toward the Anchor MSC.
- f. The Target MSC is not known to the Anchor MSC or an inter-MSC trunk to the Target MSC is not available; therefore, the Anchor MSC returns a `HandoffToThird RETURN ERROR` component to the requesting MSC.
- g. The Target MSC is known to the Tandem MSC and an inter-MSC trunk is available; therefore, the Tandem MSC attempts to perform the handoff with path minimization. It sends a `FACDIR` to the Target MSC.
- h. A voice channel on the designated target cell is available; therefore, the Target MSC increases the `Segment Counter` in the received `BillingID` parameter by one and uses the new `BillingID` for the new call segment, returns a `facdir` to the requesting MSC, and initiates a Handoff-Forward task.
- i. The Tandem MSC, having accepted the request to perform the handoff with path minimization and found a voice channel on the target system available, returns the parameters of the selected voice channel to the Serving MSC in a `handthird`.
- j. The Serving MSC receives the `handthird` and sends a Handoff Order to the MS.
- k. The MS is received on the designated voice channel; therefore, the Target MSC completes the voice path between the voice channel and the inter-MSC trunk and...
- l. ... sends a `MSONCH` to the initiator of the Handoff-Forward task, the Tandem MSC, informing the requesting system that the Target MSC has successfully completed the Handoff-Forward task.
- m. The Tandem MSC connects the call path with the inter-MSC trunk to the Target MSC, and requests release of the inter-MSC trunk to the previous Serving MSC by sending a `FACREL`, with the reason for release indicating *HandoffSuccessful*.
- n. The previous Serving MSC marks the inter-MSC trunk as idle and returns a `facrel` to the Tandem MSC, which then also marks the inter-MSC trunk as idle.
- o. The handoff is now complete.

¹The number of systems that can be involved in path minimization is limited to the value of `TANDEMDEPTH`, which is programmed by the service providers. See *IS-41.6*.

5.7. Successful Call Release by Served MS

This scenario describes the served MS-initiated release of a call that had previously been handed-off.

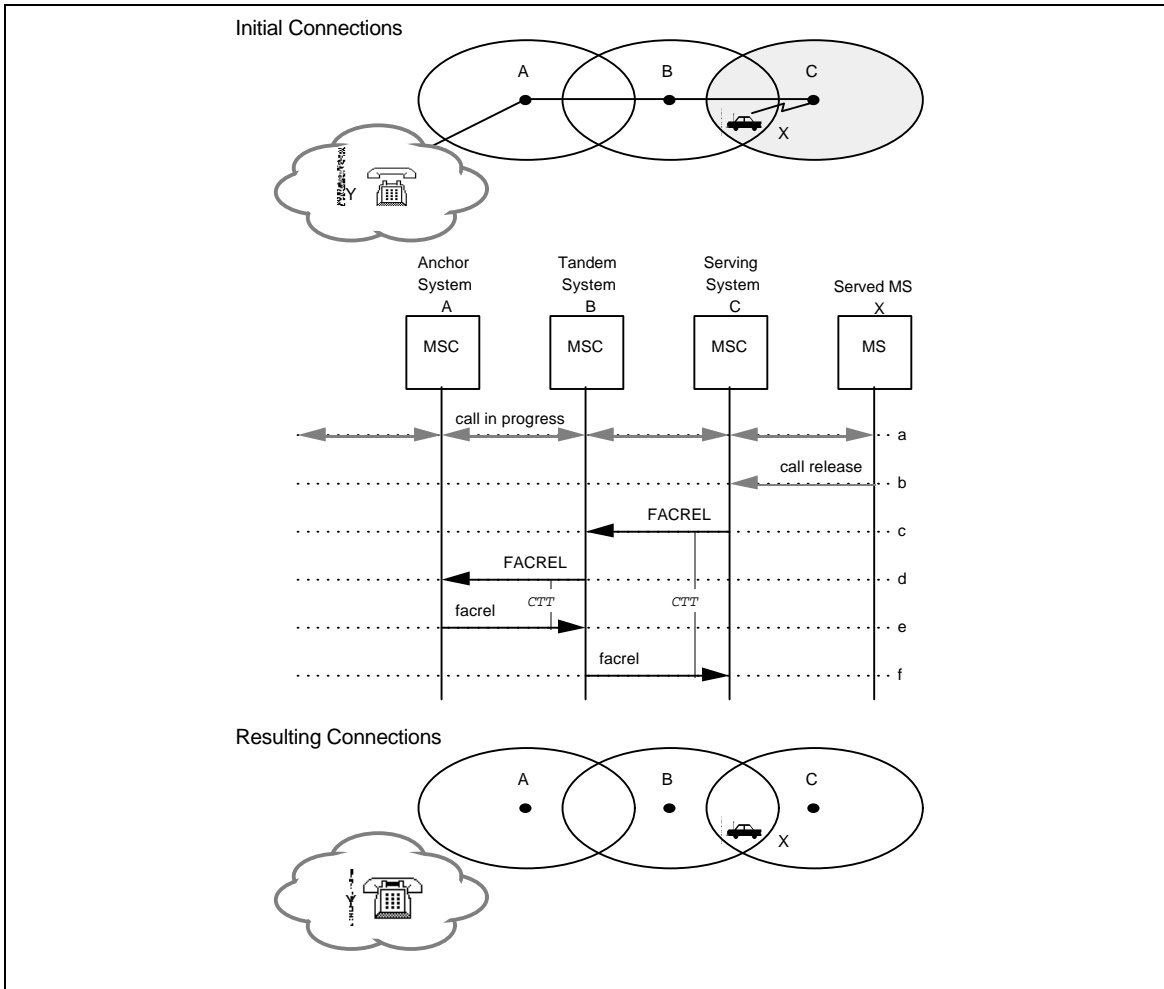

Figure 24 Successful Call Release by Served MS

- a. A call involving the served MS is in progress.
- b. The served MS releases the call.
- c. The Serving MSC determines that the inter-MSC trunk used for the call should be released; therefore, it sends a `FACREL` to the Tandem MSC, with the reason for release indicating *CallOverClearBackward*. The last Segment Counter is sent toward the Anchor MSC in the `BillingID` parameter.
- d. The Tandem MSC then sends a `FACREL` to the Anchor MSC to release the inter-MSC trunk between them.
- e. The Anchor MSC marks the inter-MSC trunk as idle and returns a `facrel` to the Tandem MSC. On receipt of the `facrel`, the Tandem MSC marks the inter-MSC trunk as idle.
- f. The Tandem MSC marks the inter-MSC trunk as idle and returns a `facrel` to the Serving MSC. On receipt of the `facrel`, the Serving MSC marks the inter-MSC trunk as idle.

1
2
3
4
5
6
7
8
9
10
11
12
13
14
15
16
17
18
19
20
21
22
23
24
25
26
27
28
29
30
31
32
33
34
35
36
37
38
39
40
41
42
43
44
45
46
47
48
49
50
51
52
53
54
55
56
57
58
59
60

5.8. Successful Call Release by Other Party

This scenario describes the release of a call that had previously been handed-off. The release is initiated by the other party to the call, not the served MS.

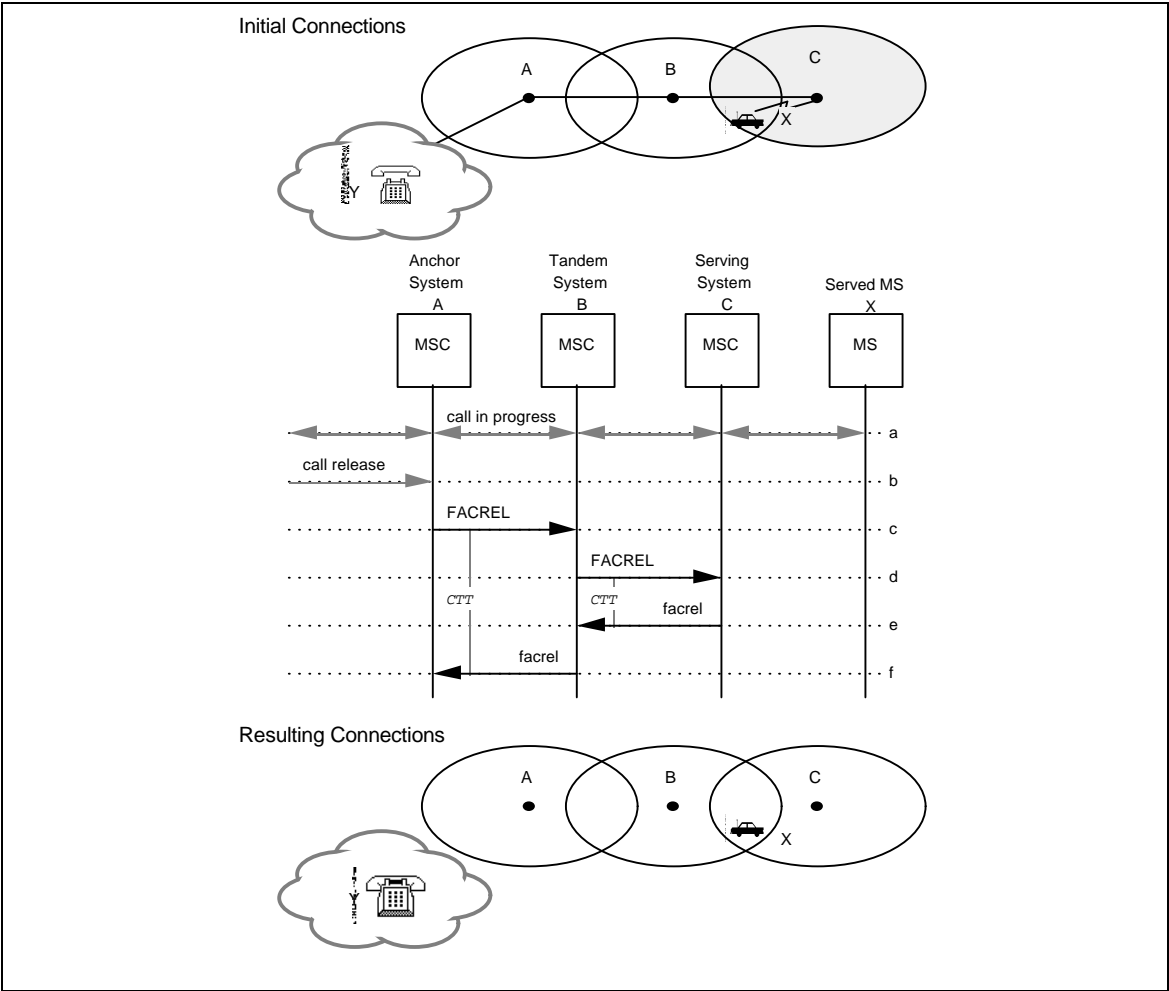

Figure 25 Successful Call Release by Other Party

- a. A call involving the served MS is in progress.
- b. A call release signal is received by the Anchor MSC. The release is initiated by the other party to the call, not the served MS.
- c. The Anchor MSC determines that the inter-MSC trunk used for the call should be released; therefore, it sends a FACREL to the Tandem MSC, with the reason for release indicating *CallOverClearForward*.
- d. The Tandem MSC then sends a FACREL to the Serving MSC to release the inter-MSC trunk between them.
- e. The Serving MSC marks the inter-MSC trunk as idle and returns a facrel to the Tandem MSC. The last Segment Counter is sent toward the Anchor MSC in the BillingID parameter. On receipt of the facrel, the Tandem MSC marks the inter-MSC trunk as idle.
- f. The Tandem MSC marks the inter-MSC trunk as idle and returns a facrel to the Anchor MSC. On receipt of the facrel, the Anchor MSC marks the inter-MSC trunk as idle.

1
2
3
4
5
6
7
8
9
10
11
12
13
14
15
16
17
18
19
20
21
22
23
24
25
26
27
28
29
30
31
32
33
34
35
36
37
38
39
40
41
42
43
44
45
46
47
48
49
50
51
52
53
54
55
56
57
58
59
60

5.9. Successful Handoff-Forward of an Originating MS Awaiting Answer

This scenario describes the successful Handoff-Forward of an originating MS that is awaiting answer.

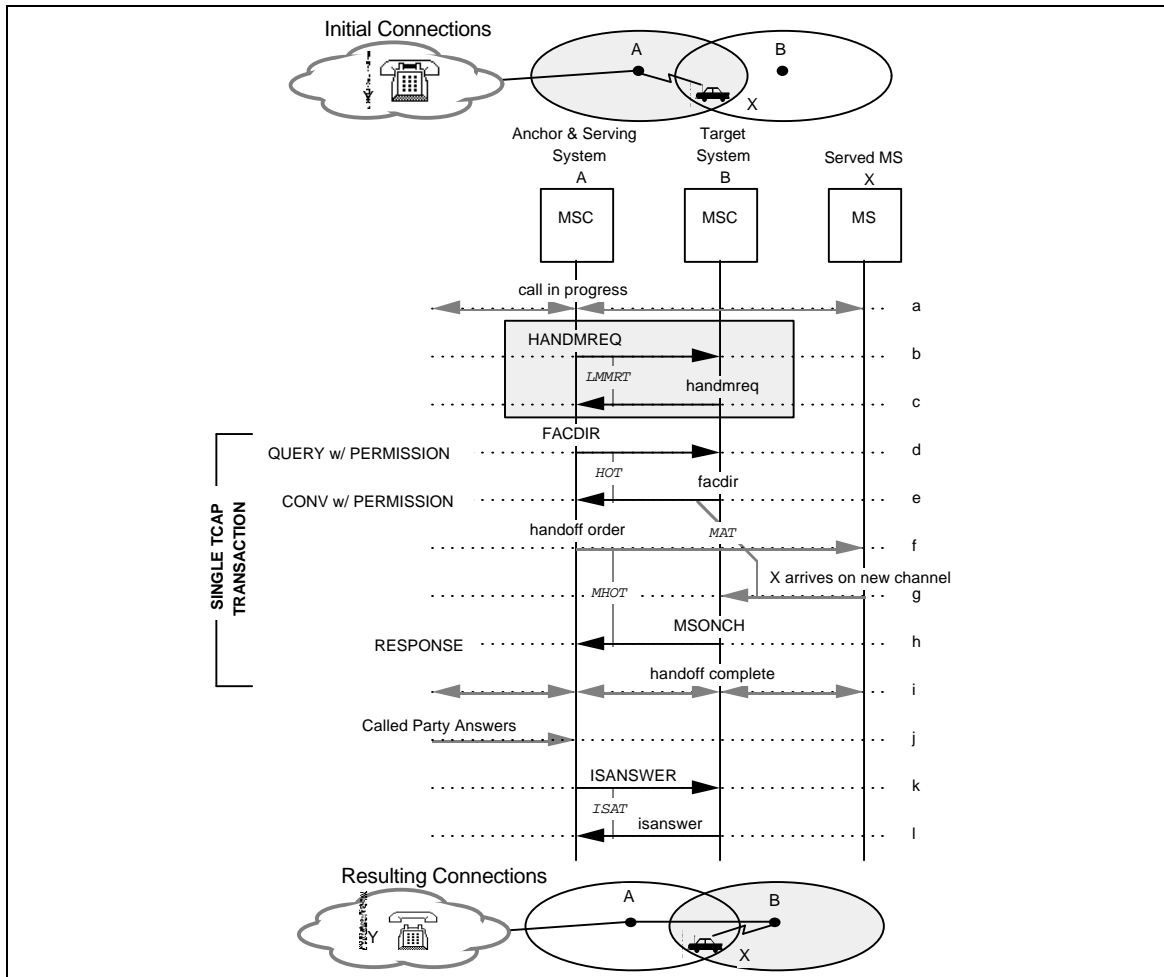

Figure 26 Successful Handoff-Forward of an Originating MS Awaiting Answer

- a. An MS has originated a call and is awaiting answer.
- b. The Serving MSC elects, based on its internal algorithm, to determine if a handoff to an adjacent MSC is appropriate. The Serving MSC sends a `HANDMREQ` to the Candidate MSC (the Serving MSC may send several handoff measurement requests to different candidate MSCs).
- c. The candidate MSC performs location measurements in accordance with the MSC's internal algorithm and returns the result to the Serving MSC in a `handmreq`.
- d. The Serving MSC determines that the call should be handed off to the Target MSC and that the Target MSC is not already on the call path. If tandem segments are counted, then the Serving MSC increments the Segment Counter of the BillingID

- parameter by one and sends a `FACDIR` to the Target MSC, directing the Target MSC to initiate a Handoff-Forward task.
- e. A voice channel on the designated target cell is available; therefore, the Target MSC increases the Segment Counter in the received `BillingID` parameter by one and uses the new `BillingID` for the new call segment, returns a `facdir` to the requesting MSC, and initiates a Handoff-Forward task.
 - f. On receipt of the `facdir`, the Serving MSC sends a Mobile Handoff Order to the served MS.
 - g. The MS is received on the designated voice channel.
 - h. The Target MSC completes the voice path between the voice channel and the inter-MSC trunk and sends a `MSONCH` to the initiator of the Handoff-Forward task, the Serving MSC, informing the requesting system that the Target MSC has successfully completed the Handoff-Forward task.
 - i. The Serving MSC, on receipt of the `MSONCH`, connects the call path to the inter-MSC trunk, completing the handoff process.
 - j. The called party answers the call.
 - k. The Anchor MSC sends an `ISANSWER` to the Serving (previously Target) MSC.
 - l. The Serving (previously Target) MSC, on receipt of `ISANSWER`, returns an `isanswer` to the requesting MSC. Optionally, a call timer may be started for billing purposes.

1
2
3
4
5
6
7
8
9
10
11
12
13
14
15
16
17
18
19
20
21
22
23
24
25
26
27
28
29
30
31
32
33
34
35
36
37
38
39
40
41
42
43
44
45
46
47
48
49
50
51
52
53
54
55
56
57
58
59
60

5.10. Successful Handoff-Forward of a Terminating MS While Alerting

This scenario describes the successful Handoff-Forward of a terminating MS while alerting.

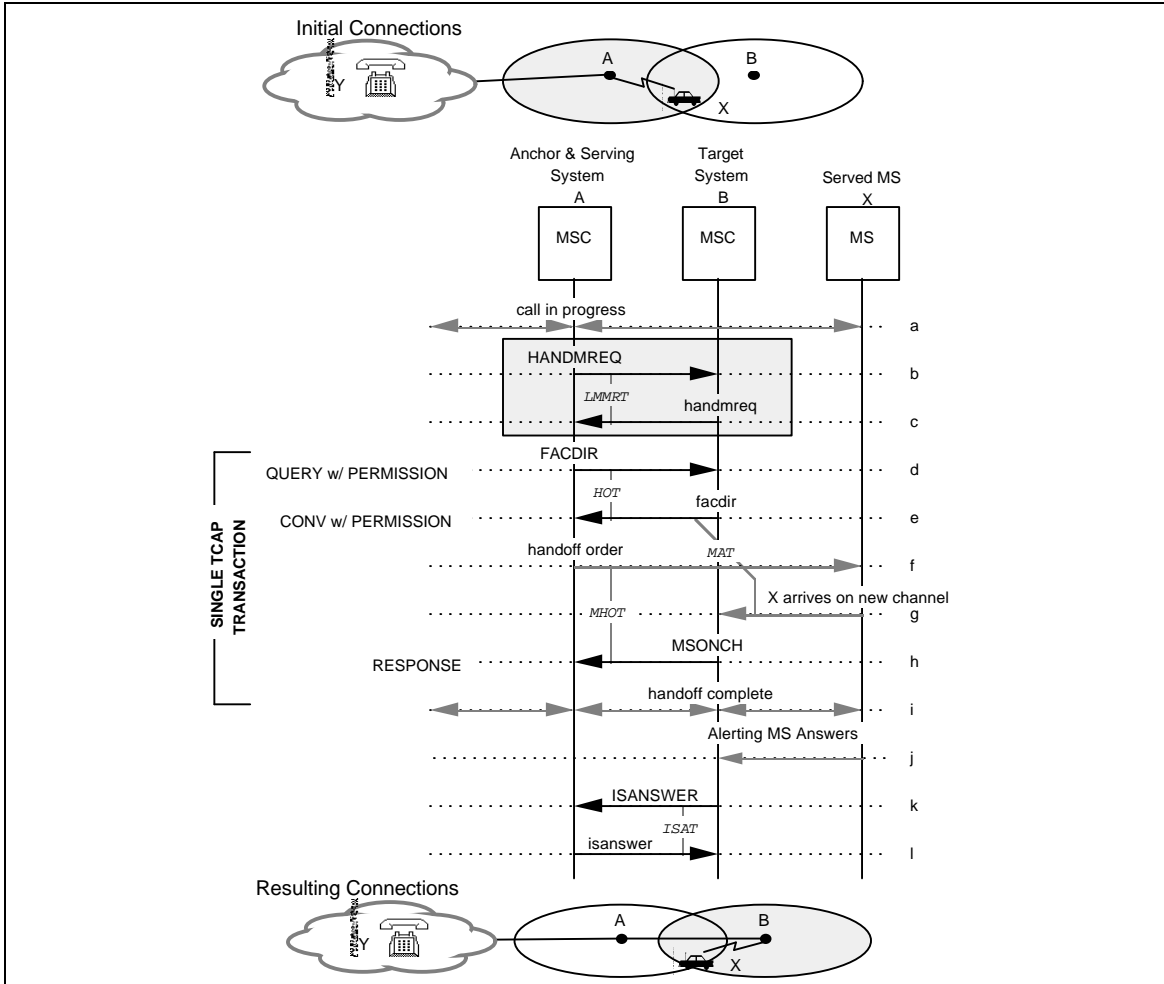

Figure 27 Successful Handoff-Forward of a Terminating MS While Alerting

- a. An MS is alerting.
- b. The Serving MSC elects, based on its internal algorithm, to determine if a handoff to an adjacent MSC is appropriate. The Serving MSC sends a `HANDMREQ` to the Candidate MSC (the Serving MSC may send several handoff measurement requests to different candidate MSCs).
- c. The candidate MSC performs location measurements in accordance with the MSC's internal algorithm and returns the result to the Serving MSC in a `handmreq`.
- d. The Serving MSC determines that the call should be handed off to the Target MSC and that the Target MSC is not already on the call path. The Serving MSC sends a `FACDIR` to the Target MSC, directing the Target MSC to initiate a Handoff-Forward task.
- e. A voice channel on the designated target cell is available; therefore, the Target MSC increases the Segment Counter in the received `BillingID` parameter by one and uses the new `BillingID` for the new call segment, returns a `facdir` to the requesting MSC, and initiates a Handoff-Forward task.
- f. On receipt of the `facdir`, the Serving MSC sends a Mobile Handoff Order to the served MS.
- g. The MS is received on the designated voice channel.
- h. The Target MSC completes the voice path between the voice channel and the inter-MSC trunk and sends a `MSONCH` to the initiator of the Handoff-Forward task, the Serving MSC, informing the requesting system that the Target MSC has successfully completed the Handoff-Forward task.
- i. The Serving MSC, on receipt of the `MSONCH`, connects the call path to the inter-MSC trunk, completing the handoff process. Continue alerting the MS.
- j. The MS answers the call.
- k. The Serving (previously Target) MSC sends an `ISANSWER` to the Anchor MSC.
- l. The Anchor MSC, on receipt of the `ISANSWER`, returns an `isanswer` to the requesting MSC. Optionally a call timer may be started for billing purposes.

Annex A (normative) Additional DMH Support for Intersystem Handoff in TIA EIA-41

This Annex is normative and is considered part of this Standard.

IS-124, the Data Message Handler (DMH) standard, has some impact upon *TIA/EIA-41*. The changes which impact *TIA/EIA-41* Intersystem Operations are:

1. Change segment numbering to include the tandem segments as well as the air time segments.
2. *DMH* requires the number of segments in a call be saved in the audit record. This information must be passed from the serving system to the anchor system upon call disconnect.

These changes are detailed in the following stage 2 diagrams. Only the scenario steps which involve *DMH* related changes are described.

1
2
3
4
5
6
7
8
9
10
11
12
13
14
15
16
17
18
19
20
21
22
23
24
25
26
27
28
29
30
31
32
33
34
35
36
37
38
39
40
41
42
43
44
45
46
47
48
49
50
51
52
53
54
55
56
57
58
59
60

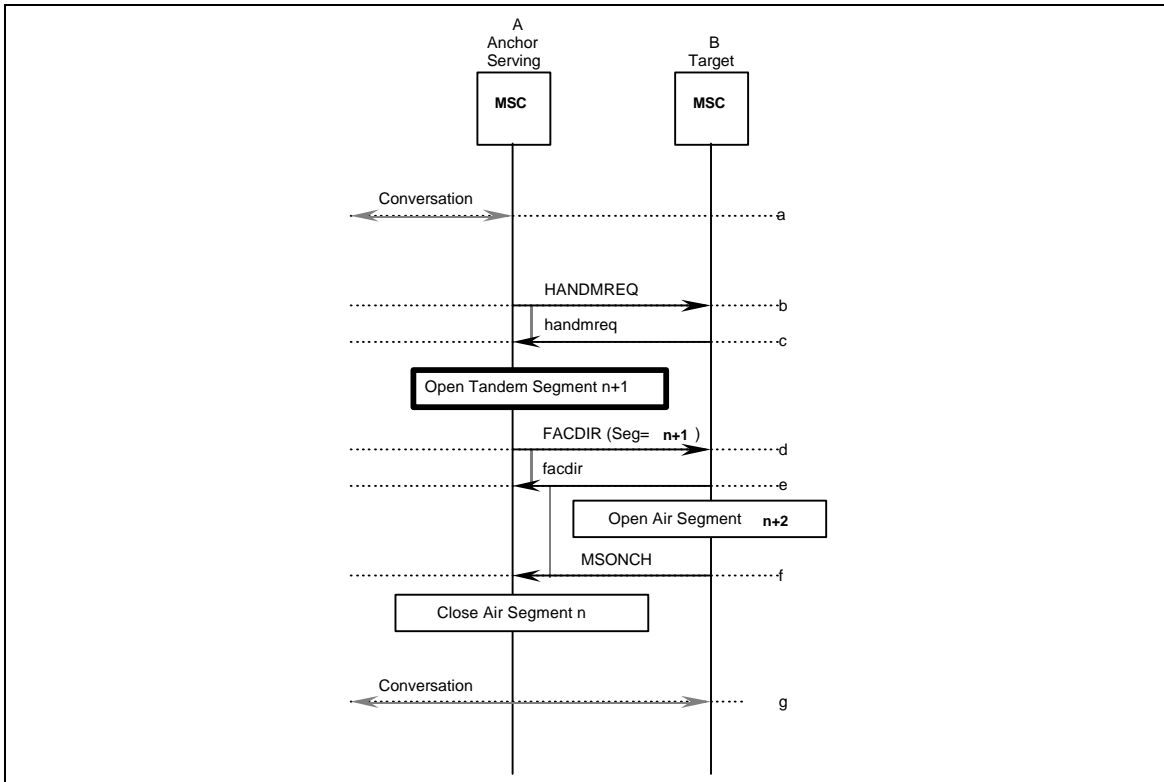

Figure A.1 Handoff-Forward (A to B)

- d. If the serving system (anchor) opens a tandem segment, it increments the current segment counter and then passes that value in the FACDIR.

1
2
3
4
5
6
7
8
9
10
11
12
13
14
15
16
17
18
19
20
21
22
23
24
25
26
27
28
29
30
31
32
33
34
35
36
37
38
39
40
41
42
43
44
45
46
47
48
49
50
51
52
53
54
55
56
57
58
59
60

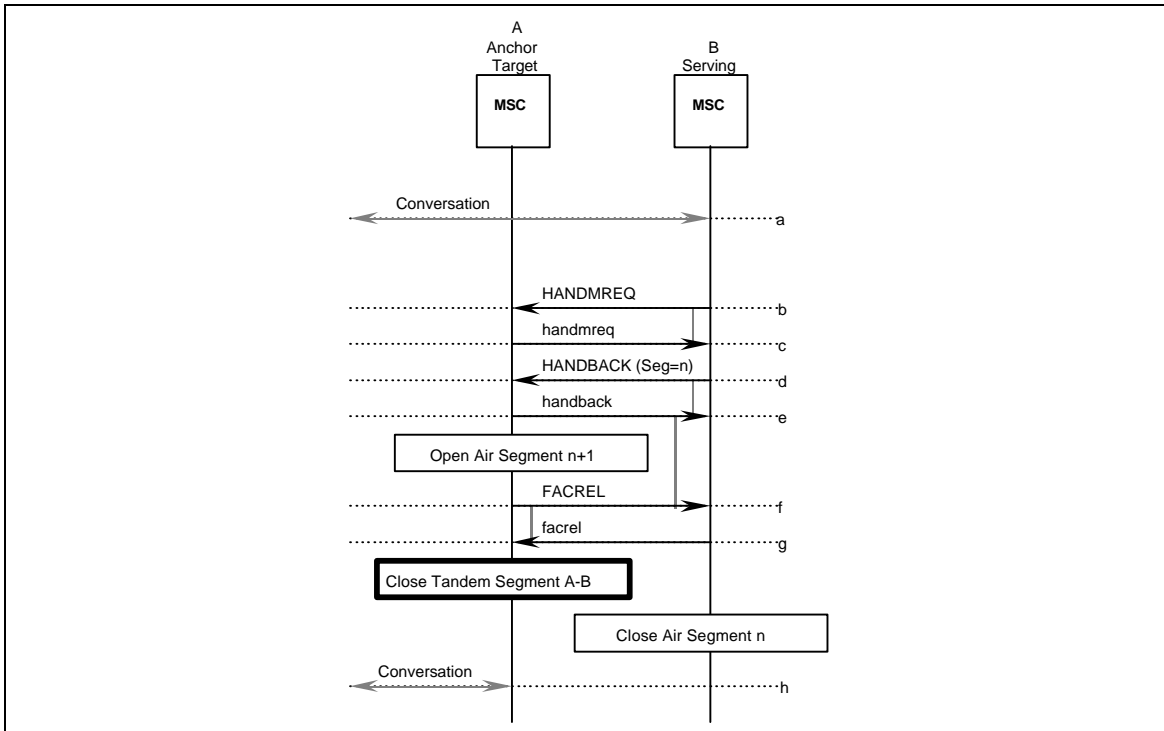

Figure A.2 Handoff-Back (B to A)

g. If the anchor had a tandem segment open, it should now close that segment.

1
2
3
4
5
6
7
8
9
10
11
12
13
14
15
16
17
18
19
20
21
22
23
24
25
26
27
28
29
30
31
32
33
34
35
36
37
38
39
40
41
42
43
44
45
46
47
48
49
50
51
52
53
54
55
56
57
58
59
60

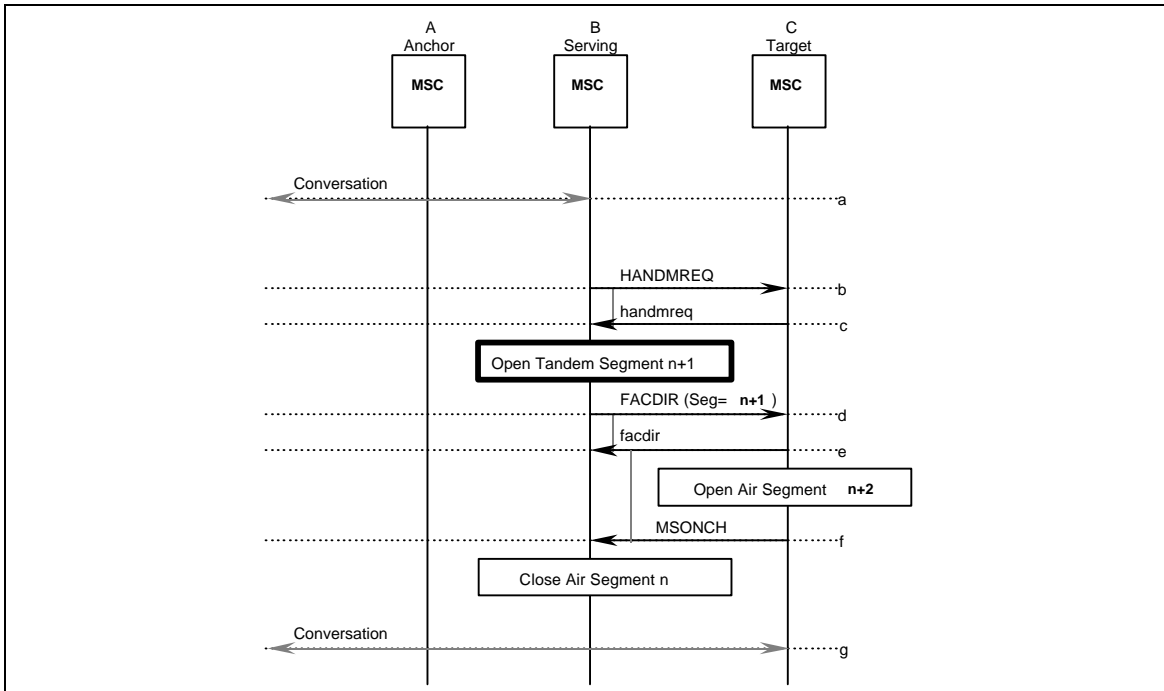

Figure A.3 Handoff-Forward (B to C)

- d. If the serving system opens a tandem segment, it increments the current segment counter and then passes that value in the FACDIR.

1
2
3
4
5
6
7
8
9
10
11
12
13
14
15
16
17
18
19
20
21
22
23
24
25
26
27
28
29
30
31
32
33
34
35
36
37
38
39
40
41
42
43
44
45
46
47
48
49
50
51
52
53
54
55
56
57
58
59
60

1
2
3
4
5
6
7
8
9
10
11
12
13
14
15
16
17
18
19
20
21
22
23
24
25
26
27
28
29
30
31
32
33
34
35
36
37
38
39
40
41
42
43
44
45
46
47
48
49
50
51
52
53
54
55
56
57
58
59
60

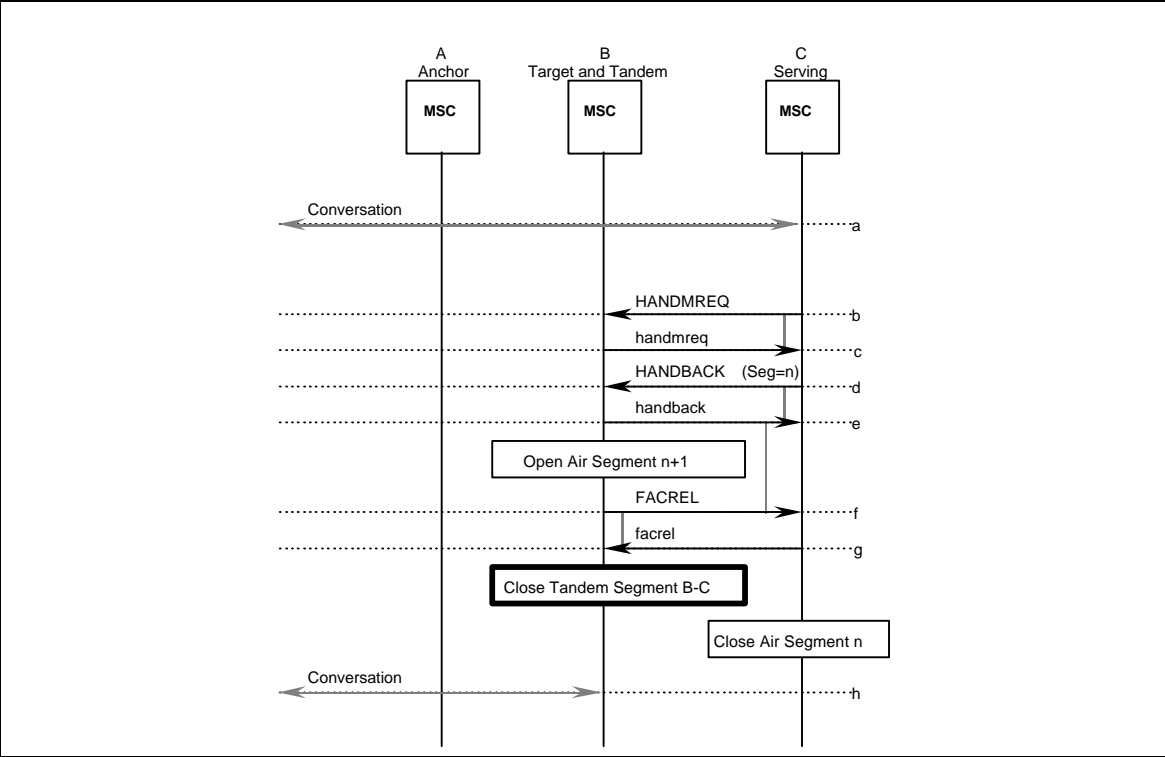

Figure A.4 Handoff-Back (C to B)

g. If the serving system opened a tandem segment, it should close it now.

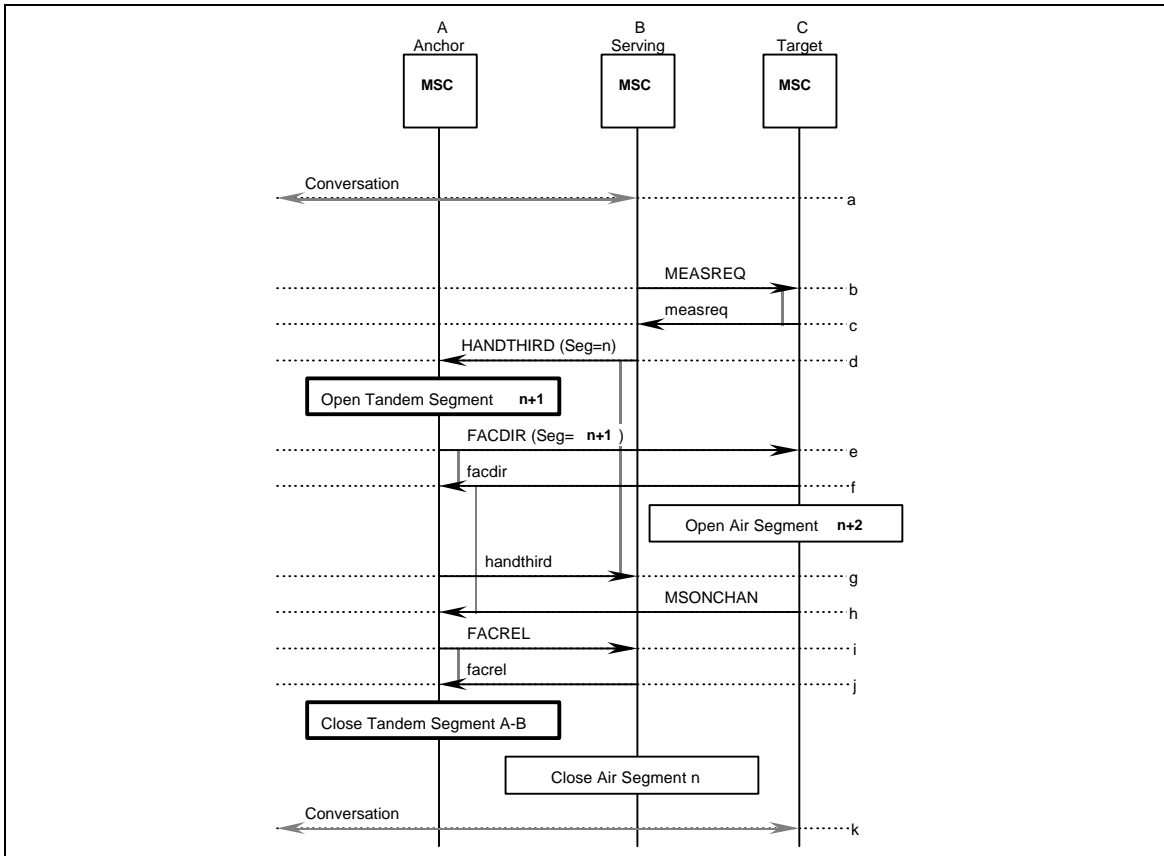

Figure A.5 Path Minimization (A-B to A-C)

- d. If the anchor system opens a tandem segment, it increments the current segment counter and then passes that value in the **FACDIR**.
- j. If the serving system opened a tandem segment, it should close it now.

1
2
3
4
5
6
7
8
9
10
11
12
13
14
15
16
17
18
19
20
21
22
23
24
25
26
27
28
29
30
31
32
33
34
35
36
37
38
39
40
41
42
43
44
45
46
47
48
49
50
51
52
53
54
55
56
57
58
59
60

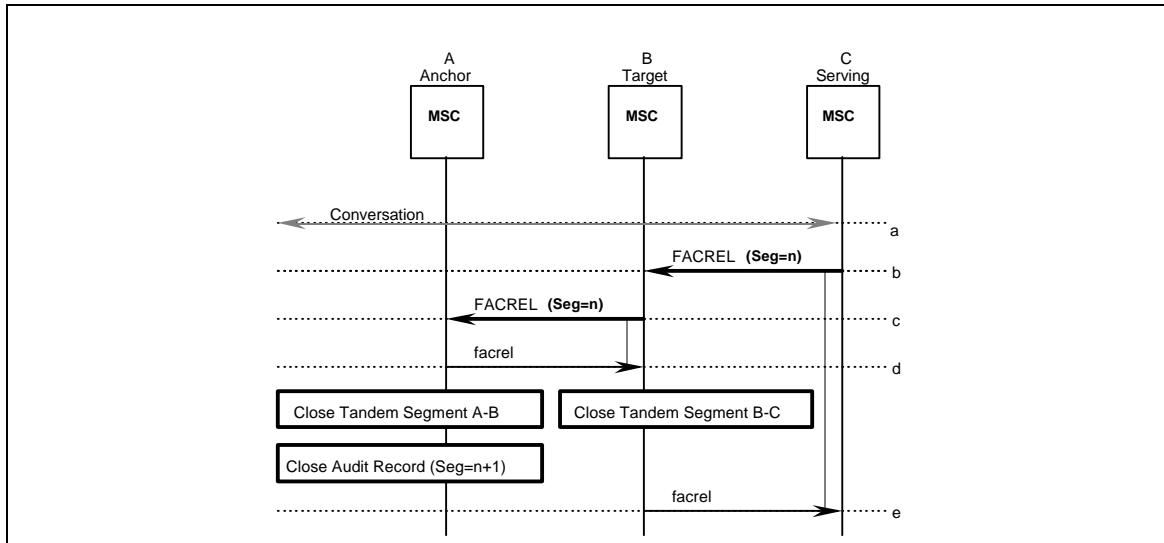

Figure A.6 Release by the MS (C-B-A)

- b. When the serving system detects that the MS has disconnected or has lost radio contact, it signals the release of the facilities with a FACREL including the number of segments currently allocated.
- d. When a tandem system processes a FACREL containing the number of segments in a BillingID, it should relay that parameter toward the Anchor MSC.

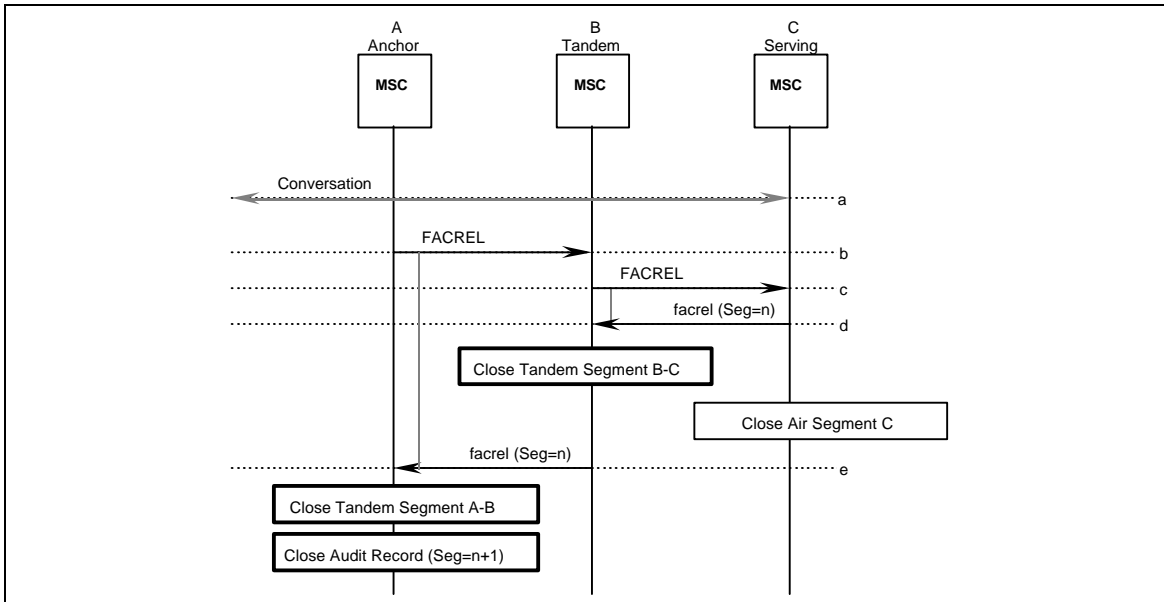

Figure A.7 Release by the other party (A-B-C)

- b. When the Anchor MSC receives a disconnect request from the other party for a handed off MS, it should launch a FACREL and start a timer to wait for the response. If the timer expires, an indicator for an unknown number of segments can be used.
- c. When a Tandem MSC receives a FACREL from the Anchor MSC for a handed off MS, it should launch a FACREL toward the Serving MSC and start a timer to wait for the response. If the timer expires, an indicator for an unknown number of segments can be used.

Upon receipt of the FACREL the Serving MSC can release any facilities that it is using and close out the current air segment DMH record. It confirms the release by sending a facrel to the Tandem MSC including the BillingID to convey the number of segments.

- d. When a Tandem MSC receives a facrel from the Serving MSC for a handed off MS, it can release any facilities that it is using and close out the current tandem segment DMH record. It confirms the release by sending a facrel to the Tandem MSC including the BillingID to convey the number of segments.
- e. When the Anchor MSC receives a facrel from the Tandem or Serving MSC for a handed off MS, it can release any facilities that it is using and close out the current tandem segment DMH record and the audit record for the call with the number of segments.

1
2
3
4
5
6
7
8
9
10
11
12
13
14
15
16
17
18
19
20
21
22
23
24
25
26
27
28
29
30
31
32
33
34
35
36
37
38
39
40
41
42
43
44
45
46
47
48
49
50
51
52
53
54
55
56
57
58
59
60

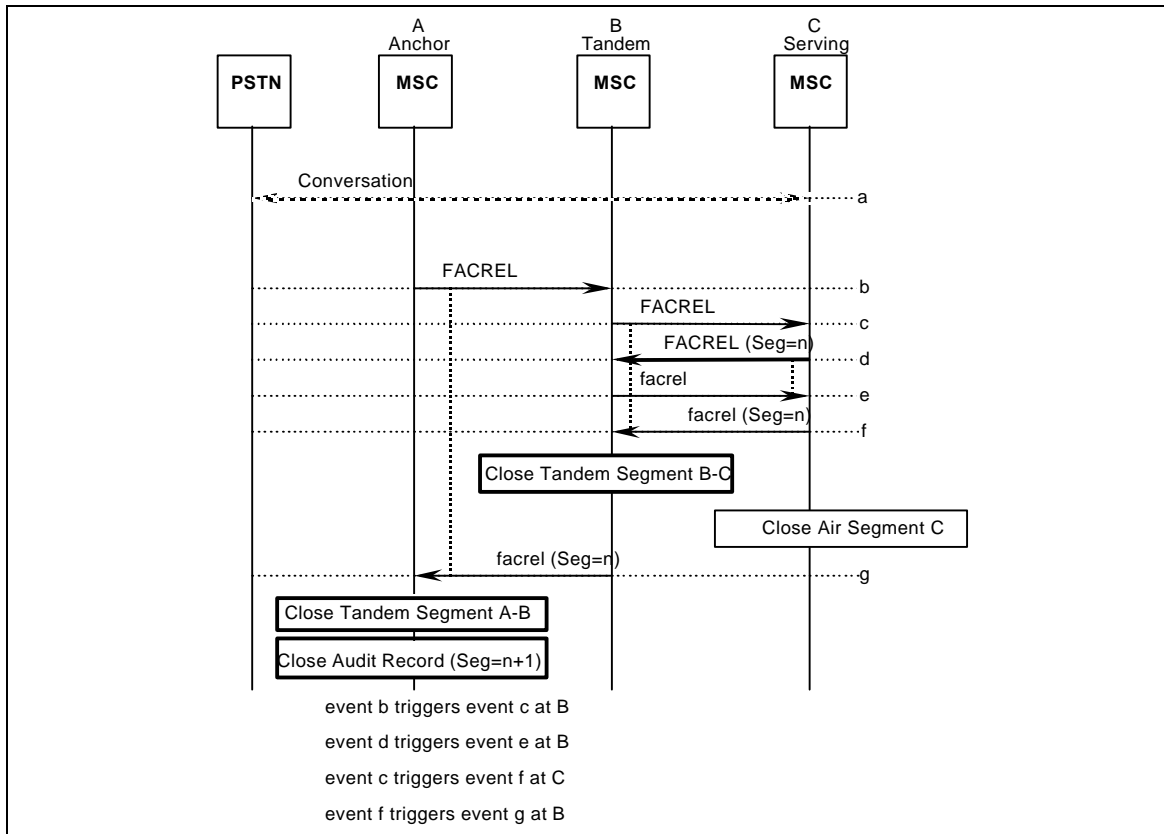

33
34
35
36
37
38

Figure A.8 Release Glare

- 39
40
41
42
43
44
45
46
47
48
49
50
51
52
53
54
55
56
57
58
59
60
- When the Anchor MSC receives a disconnect request from the other party for a handed off MS, it should launch a FACREL and start a timer to wait for the response. If the timer expires, an indicator for an unknown number of segments can be used.
 - When a Tandem MSC receives a FACREL from the Anchor MSC for a handed off MS, it should launch a FACREL toward the Serving MSC and start a timer to wait for the response. If the timer expires, an indicator for an unknown number of segments can be used.
- Upon receipt of the FACREL the Serving MSC can release any facilities that it is using and close out the current air segment DMH record. It confirms the release by sending a facrel to the Tandem MSC including the BillingID to convey the number of segments.
- The Serving MSC detects a disconnect request from the MS and sends a FACREL toward the Anchor MSC with the number of segments. The Serving MSC is unaware that the other end is releasing simultaneously.
 - The Tandem MSC receives the FACREL and is free to release any resources that it may have seized.

1
2
3
4
5
6
7
8
9
10
11
12
13
14
15
16
17
18
19
20
21
22
23
24
25
26
27
28
29
30
31
32
33
34
35
36
37
38
39
40
41
42
43
44
45
46
47
48
49
50
51
52
53
54
55
56
57
58
59
60

When the Serving MSC receives a `facrel` from the Tandem or Serving MSC for a handed off MS, it can release any facilities that it is using and close out the current air segment DMH record.

- f. The Tandem MSC receives the `facrel` from the Serving MSC and is free to release any resources that it may have seized and close the tandem segment DMH record.
- g. The Tandem MSC sends the `facrel` to the Anchor MSC include the number of segments.

When the Anchor MSC receives a `facrel` from the Tandem or Serving MSC for a handed off MS, it can release any facilities that it is using and close out the current tandem segment DMH record and the audit record for the call with the number of segments.

CELLULAR RADIOTELECOMMUNICATIONS INTERSYSTEM OPERATIONS:
CHAPTER 3
AUTOMATIC ROAMING INFORMATION FLOWS

CONTENTS

12 LIST OF FIGURES.....x

14 LIST OF TABLES.....xvi

16 FOREWORD.....xvii

18 REVISION HISTORY..... xviii

20 1 INTRODUCTION..... 1

21 1.1 OBJECTIVE..... 1

22 1.2 SCOPE..... 1

23 1.3 ORGANIZATION..... 2

26 2 REFERENCES..... 2

28 3 TERMINOLOGY..... 2

29 3.1 DEFINITIONS 2

30 3.2 SYMBOLS AND ABBREVIATIONS..... 3

31 3.3 DOCUMENTATION CONVENTIONS..... 5

32 4 AUTOMATIC ROAMING OPERATIONS..... 6

33 4.1 AuthenticationDirective 6

34 4.1.1 Initiate SSD Update (New SSD shared for SSD Update).....7

35 4.1.2 Initiate SSD Update (SSD not shared for SSD Update).....9

36 4.1.3 Initiate CallHistoryCount Update..... 11

37 4.1.4 VLR-Initiated Unique Challenge 13

38 4.1.5 AC-Initiated Unique Challenge 14

39 4.1.6 Revocation of SSD Sharing 16

40 4.2 AuthenticationDirectiveForward 17

41 4.2.1 Successful AuthenticationDirectiveForward..... 17

42 4.3 AuthenticationFailureReport 19

43 4.3.1 Successful AuthenticationFailureReport: Access Denied on Initial
44 Registration..... 19

45 4.4 AuthenticationRequest 21

46 4.4.1 Successful Authentication on Initial Access 22

47 4.4.2 Failed Authentication on Initial Access 25

48 4.4.3 Successful Authentication on Call Origination (SSD not shared) 26

49 4.4.4 Successful Authentication on Call Termination (SSD not shared) 29

1
2
3
4
5
6
7
8
9
10
11
12
13
14
15
16
17
18
19
20
21
22
23
24
25
26
27
28
29
30
31
32
33
34
35
36
37
38
39
40
41
42
43
44
45
46
47
48
49
50
51
52
53
54
55
56
57
58
59
60

1
2
3
4
5
6
7
8
9
10
11
12
13
14
15
16
17
18
19
20
21
22
23
24
25
26
27
28
29
30
31
32
33
34
35
36
37
38
39
40
41
42
43
44
45
46
47
48
49
50
51
52
53
54
55
56
57
58
59
60

4.4.5	Initiate Authentication on Voice Channel (SSD not shared)	31
4.4.6	Successful Authentication on Call Origination (SSD shared)	33
4.4.7	Successful Authentication on Call Termination (SSD shared)	34
4.4.8	Initiate Authentication on Voice Channel (SSD shared)	35
4.5	AuthenticationStatusReport	36
4.5.1	Report of AC-initiated Action	37
4.5.2	Report of VLR-initiated Action	40
4.6	BaseStationChallenge	41
4.6.1	Base Station Challenge with SSD not shared	42
4.6.2	Base Station Challenge with SSD shared	44
4.7	BulkDeregistration	45
4.7.1	Successful BulkDeregistration	45
4.8	CountRequest	46
4.8.1	Successful CountRequest	46
4.9	FeatureRequest	48
4.9.1	Direct FeatureRequest without Call Routing	49
4.9.2	Direct FeatureRequest with Call Routing	51
4.10	FlashRequest	53
4.10.1	Successful FlashRequest	53
4.11	InformationDirective	55
4.11.1	Successful InformationDirective	55
4.12	InformationForward	57
4.12.1	Successful InformationForward	57
4.13	InterSystemAnswer	59
4.13.1	Successful InterSystemAnswer	59
4.14	InterSystemPage	60
4.14.1	Successful InterSystemPage: Border MSC Routing Information Returned	60
4.14.2	Unsuccessful InterSystemPage: Border MSC Access Denied	63
4.14.3	Unsuccessful InterSystemPage: Border MSC Resource Shortage	64
4.15	InterSystemPage2	65
4.15.1	Successful InterSystemPage2: MS Presence Confirmed in Border MSC	65
4.15.2	Unsuccessful InterSystemPage2: Access Denied	68
4.15.3	Unsuccessful InterSystemPage2: Resource Shortage	69
4.16	InterSystemSetup	70
4.16.1	Successful InterSystemSetup	70
4.16.2	Unsuccessful InterSystemSetup	72
4.17	LocationRequest	73
4.17.1	Successful LocationRequest: Route to aPSTN DN	74
4.17.2	Successful LocationRequest: Route to a Local MS	76
4.17.3	Successful LocationRequest: Route to an MS on Another MSC	77
4.17.4	Successful LocationRequest: Routing Information and Access Denied Indication Returned	78
4.17.5	Successful LocationRequest: Route to Multiple Terminations	79

1
2
3
4
5
6
7
8
9
10
11
12
13
14
15
16
17
18
19
20
21
22
23
24
25
26
27
28
29
30
31
32
33
34
35
36
37
38
39
40
41
42
43
44
45
46
47
48
49
50
51
52
53
54
55
56
57
58
59
60

4.17.6	Unsuccessful LocationRequest: Access Denied without Routing Information Returned	80
4.18	MSInactive	82
4.18.1	Successful MSInactive: MS Declared Inactive.....	83
4.18.2	Successful MSInactive: MS Deregistered.....	84
4.19	OriginationRequest	86
4.19.1	Successful OriginationRequest	86
4.19.2	Unsuccessful OriginationRequest	88
4.20	QualificationDirective.....	89
4.20.1	Successful QualificationDirective: Re-authorization Only.....	90
4.20.2	Successful QualificationDirective: Re-authorization and Update Profile	92
4.20.3	Successful QualificationDirective: Update Profile Only.....	94
4.20.4	Successful QualificationDirective: De-authorization	95
4.21	QualificationRequest.....	97
4.21.1	Successful QualificationRequest: Authorization Confirmed	97
4.21.2	Successful QualificationRequest: Authorization Confirmed and Profile Returned	99
4.21.3	Successful QualificationRequest: Profile Returned Only.....	102
4.21.4	Unsuccessful QualificationRequest: Authorization Denied.....	103
4.22	RandomVariableRequest.....	104
4.22.1	Successful RandomVariableRequest.....	104
4.22.2	Unsuccessful RandomVariableRequest.....	105
4.23	RedirectionDirective	106
4.23.1	Successful Request.....	107
4.23.2	Unsuccessful Request.....	108
4.24	RedirectionRequest.....	109
4.24.1	Successful RedirectionRequest.....	110
4.24.2	Unsuccessful RedirectionRequest.....	111
4.25	RegistrationCancellation	112
4.25.1	Successful RegistrationCancellation: Single Access	113
4.25.2	Successful RegistrationCancellation: Multiple Access.....	115
4.25.3	Unsuccessful RegistrationCancellation: Multiple Access.....	117
4.26	RegistrationNotification.....	118
4.26.1	Successful RegistrationNotification: Confirmed at the VLR.....	118
4.26.2	Successful RegistrationNotification: Confirmed at the HLR.....	122
4.26.3	Unsuccessful RegistrationNotification: Denied at the HLR.....	124
4.27	RemoteFeatureControlRequest.....	126
4.28	RemoteUserInteractionDirective.....	127
4.28.1	Successful RemoteUserInteractionDirective.....	127
4.28.2	Unsuccessful RemoteUserInteractionDirective.....	128
4.29	RoutingRequest.....	129
4.29.1	Successful Indirect RoutingRequest: TLDN Returned.....	130
4.29.2	Successful Direct RoutingRequest: TLDN Returned.....	133
4.29.3	Unsuccessful Indirect RoutingRequest: Access Denied Returned.....	134

1
2
3
4
5
6
7
8
9
10
11
12
13
14
15
16
17
18
19
20
21
22
23
24
25
26
27
28
29
30
31
32
33
34
35
36
37
38
39
40
41
42
43
44
45
46
47
48
49
50
51
52
53
54
55
56
57
58
59
60

4.30	SMSDeliveryBackward.....	135
4.30.1	Successful SMSDeliveryBackward.....	136
4.30.2	Unsuccessful SMSDeliveryBackward.....	138
4.31	SMSDeliveryForward.....	139
4.31.1	Successful SMSDeliveryForward.....	140
4.31.2	Unsuccessful SMSDeliveryForward.....	142
4.32	SMSDeliveryPointToPoint.....	143
4.32.1	Successful SMSDeliveryPointToPoint.....	144
4.32.2	Unsuccessful SMSDeliveryPointToPoint.....	146
4.33	SMSNotification.....	147
4.33.1	Successful SMSNotification: MS-Based SME Availability Report.....	147
4.33.2	Successful SMSNotification: MS-Based SME Unavailability Report.....	148
4.34	SMSRequest.....	149
4.34.1	Successful SMSRequest: MS-Based SME Address Request.....	150
4.34.2	Unsuccessful SMSRequest: MS-Based SME Address Request.....	151
4.35	TransferToNumberRequest.....	153
4.35.1	Successful TransferToNumberRequest.....	153
4.35.2	Unsuccessful TransferToNumberRequest: Access Denied.....	156
4.36	UnreliableRoamerDataDirective.....	157
4.36.1	Successful UnreliableRoamerDataDirective.....	157
4.37	UnsolicitedResponse.....	158
4.37.1	Successful UnsolicitedResponse.....	158
4.37.2	Unsuccessful UnsolicitedResponse with Return Result.....	161
5	BASIC AUTOMATIC ROAMING SCENARIOS.....	162
5.1	Registration.....	163
5.1.1	Initial MS Registration in a New Serving System.....	163
5.1.2	Multiple Registrations with Cancellation Denied at the VLR.....	165
5.2	Deregistration.....	167
5.2.1	MS Deregistered by Serving MSC.....	167
5.2.2	MS Deregistered by Serving VLR.....	168
5.3	MS Inactivity Reporting.....	169
5.3.1	Registered MS Declared Inactive by Serving MSC.....	169
5.3.2	MS Declared Inactive by Serving MSC at Registration.....	170
5.3.3	MS Declared Inactive by Serving VLR.....	171
5.3.4	MS Reported Inactive via the RoutingRequest Operation.....	171
5.4	Authentication.....	172
5.4.1	Initial Registration with Authentication.....	173
5.4.2	Origination with Authentication.....	175
5.4.3	Termination with Authentication.....	178
5.4.4	Authentication on Voice Channel Only.....	181
5.4.5	Authentication on Flash Request.....	183
5.4.6	SSD Update When SSD is Not Shared.....	185
5.4.7	AC Initiated CallHistoryCount Update with SSD Not Shared.....	189

1			
2			
3		5.4.8	Authentication When SSD is Currently Shared with Another System 191
4		5.4.9	SSD Update When SSD is Shared..... 193
5		5.4.10	AC Initiated Unique Challenge 196
6		5.4.11	VLR Initiated Unique Challenge When SSD is Shared 198
7		5.4.12	RegistrationCancellation with CallHistoryCount Report..... 200
8			
9	5.5		Basic Feature Processing..... 202
10		5.5.1	Feature Request Confirmation with Release..... 202
11		5.5.2	Feature Request Confirmation with Call Routing 204
12		5.5.3	Feature Request Denial with Call Release 205
13		5.5.4	Feature Request After Handoff..... 206
14		5.5.5	Service Provider Initiated Profile Change..... 208
15		5.5.6	Call Origination without Profile 209
16		5.5.7	Termination or Message Delivery without Profile 210
17		5.5.8	Feature Request (Registration) with SPINI Active..... 211
18			
19	5.6		Automatic Roaming Maintenance..... 213
20		5.6.1	Recovery from Data Failure at the HLR..... 213
21		5.6.2	VLR-Initiated Bulk Deregistration 214
22			
23			
24			
25	6		VOICE FEATURE SCENARIOS..... 215
26		6.1	Call Delivery 215
27		6.1.1	CD Demand Activation or De-Activation 215
28		6.1.2	CD Invocation to an Idle MS on Another MSC 216
29		6.1.3	CD Invocation to an Idle, Local MS..... 218
30		6.1.4	CD Invocation to a Busy MS 219
31		6.1.5	CD Invocation with No Page Response or No Answer..... 220
32		6.1.6	CD Invocation to an Inaccessible MS..... 221
33		6.1.7	CD Invocation with Intersystem Paging 222
34		6.1.8	CD Invocation with Unsolicited Page Response..... 226
35		6.1.9	TLDN Call Arrival with Intersystem Paging 228
36		6.1.10	TLDN Call Arrival with No Page Response to Intersystem Paging..... 230
37		6.1.11	TLDN Call Arrival with No Answer After Intersystem Paging, Call Release Initiated by Serving MSC 231
38		6.1.12	TLDN Call Arrival with No Answer After Intersystem Paging, Call Release Initiated by Border MSC 233
39		6.1.13	Origination in a Neighboring System 235
40			
41			
42			
43			
44			
45			
46	6.2		Call Forwarding— Busy..... 237
47		6.2.1	CFB Variable Registration or De-Registration 237
48		6.2.2	CFB Demand Activation with Courtesy Call..... 237
49		6.2.3	CFB Demand Activation (without Courtesy Call) or De-Activation..... 237
50		6.2.4	CFB Invocation..... 238
51		6.2.5	CFB Invocation with Call Collision 239
52			
53	6.3		Call Forwarding— Default..... 241
54		6.3.1	CFD Variable Registration or De-Registration 241
55		6.3.2	CFD Demand Activation with Courtesy Call..... 241
56		6.3.3	CFD Demand Activation (without Courtesy Call) or De-Activation 241
57			
58			
59			
60			

1
2
3
4
5
6
7
8
9
10
11
12
13
14
15
16
17
18
19
20
21
22
23
24
25
26
27
28
29
30
31
32
33
34
35
36
37
38
39
40
41
42
43
44
45
46
47
48
49
50
51
52
53
54
55
56
57
58
59
60

6.3.4	CFD Invocation with Busy	241
6.3.5	CFD Invocation with Call Collision	241
6.3.6	CFD Invocation— Immediate.....	242
6.3.7	CFD Invocation with No Answer or No Response to Page	243
6.4	Call Forwarding— No Answer.....	245
6.4.1	CFNA Variable Registration or De-Registration	245
6.4.2	CFNA Demand Activation with Courtesy Call.....	245
6.4.3	CFNA Demand Activation (without Courtesy Call) or De-Activation.....	245
6.4.4	CFNA Invocation— Immediate.....	245
6.4.5	CFNA Invocation— Delayed.....	246
6.5	Call Forwarding— Unconditional.....	247
6.5.1	CFU Variable Registration or De-Registration	247
6.5.2	CFU Demand Activation with Courtesy Call.....	247
6.5.3	CFU Demand Activation (without Courtesy Call) or De-Activation	247
6.5.4	CFU Invocation with Alert	248
6.6	Call Transfer	249
6.7	Call Waiting	250
6.7.1	CW Demand Activation or De-Activation.....	250
6.7.2	CW Demand Cancellation with Call	250
6.7.3	CW Demand Cancellation (during call)	252
6.7.4	CW Invocation.....	253
6.7.5	CW Interaction after Handoff	255
6.8	Calling Number Identification Presentation	257
6.8.1	CNIP Invocation to an Idle Subscriber	257
6.8.2	CNIP Interaction with CW.....	259
6.8.3	CNIP Interaction with CW After Handoff.....	261
6.8.4	CNIP Interaction with CFU	263
6.8.5	CNIP Interaction with CFU after Handoff.....	265
6.9	Calling Number Identification Restriction	266
6.9.1	CNIR Temporary Activation or De-Activation with Call.....	266
6.9.2	CNIR Interaction with CFU	268
6.9.3	CNIR Interaction with CFNA or CFD on MS No Answer	270
6.9.4	CNIR Interaction with CFB or CFD on MS Busy.....	273
6.9.5	CNIR Interaction with CFB or CFD on Call Collision.....	275
6.10	Conference Calling	276
6.10.1	CC Invocation with Call Setup Request	277
6.10.2	CC Add Party (Without Feature Code Entry)	279
6.10.3	CC Invocation During a Call	281
6.10.4	CC Drop Last Party Invocation.....	283
6.11	Do Not Disturb	285
6.11.1	DND Activation or De-Activation	285
6.11.2	DND Invocation.....	285
6.11.3	DND Interaction with CFD or CFNA.....	286
6.11.4	DND Interaction with CFU.....	286

1
2
3
4
5
6
7
8
9
10
11
12
13
14
15
16
17
18
19
20
21
22
23
24
25
26
27
28
29
30
31
32
33
34
35
36
37
38
39
40
41
42
43
44
45
46
47
48
49
50
51
52
53
54
55
56
57
58
59
60

- 6.12 Flexible Alerting 287
 - 6.12.1 FA Membership Activation or De-Activation..... 287
 - 6.12.2 FA Invocation 287
 - 6.12.3 FA Invocation with a Busy FA Group Member (Single-User Type)..... 291
 - 6.12.4 FA Invocation with a Busy FA Group Member..... 293
 - 6.12.5 FA Invocation with a No Answer FA Group Member with Member Redirection..... 295
 - 6.12.6 FA Invocation with a No Answer FA Group Member with Group Redirection..... 298
 - 6.12.7 FA Invocation on Revertive Call to FA Pilot DN 300
 - 6.12.8 FA Invocation on Call from FA Group Member..... 303
- 6.13 Message Waiting Notification 306
 - 6.13.1 MWN Alert Pip Tone Activation or De-Activation 306
 - 6.13.2 Temporary De-Activation of MWN PIP Tone..... 306
 - 6.13.3 MWN via Alert Pip Tones 308
 - 6.13.4 MWN via an MS Indication or Message Count or Both..... 310
 - 6.13.5 MWN After Handoff..... 311
 - 6.13.6 MWN via Pip Tone on MS Call Origination 313
 - 6.13.7 MWN via Pip Tone on MS Termination 314
- 6.14 Mobile Access Hunting..... 315
 - 6.14.1 MAH Membership Activation or De-Activation..... 315
 - 6.14.2 MAH Ordering Change Request 315
 - 6.14.3 MAH Invocation 315
 - 6.14.4 MAH Invocation with a Busy MAH Group Member..... 320
 - 6.14.5 MAH Invocation with a Busy MAH Group Member..... 322
 - 6.14.6 MAH Invocation with a No Answer MAH Group Member 324
 - 6.14.7 MAH Invocation on Revertive Call to MAH Pilot DN 328
 - 6.14.8 MAH Invocation on Call from MAH Group Member..... 330
- 6.15 Password Call Acceptance..... 333
 - 6.15.1 PCA Demand Activation or De-Activation 333
 - 6.15.2 PCA Variable Diversion Registration or De-Registration 333
 - 6.15.3 PCA Password Registration or De-Registration..... 333
 - 6.15.4 PCA Invocation with Call Accepted..... 334
 - 6.15.5 PCA Invocation with Call Accepted: Alternate Procedure 336
 - 6.15.6 PCA Invocation with Call Refused to Tone or Announcement..... 338
 - 6.15.7 PCA Invocation with Call Refused to Voice Mail 339
 - 6.15.8 PCA Invocation with Call Refused to Forward-To Number..... 340
- 6.16 Preferred Language..... 341
 - 6.16.1 PL Registration (variable option)..... 341
- 6.17 Priority Access and Channel Assignment..... 343
 - 6.17.1 Successful PACA Activation..... 343
 - 6.17.2 Aborted PACA Activation..... 345
 - 6.17.3 Unsuccessful PACA Activation..... 346
- 6.18 Remote Feature Control 347

1
2
3
4
5
6
7
8
9
10
11
12
13
14
15
16
17
18
19
20
21
22
23
24
25
26
27
28
29
30
31
32
33
34
35
36
37
38
39
40
41
42
43
44
45
46
47
48
49
50
51
52
53
54
55
56
57
58
59
60

6.18.1	Normal RFC Transaction Sequence	347
6.19	Selective Call Acceptance	350
6.19.1	SCA Demand Activation or De-Activation	350
6.19.2	SCA Variable Diversion Registration	350
6.19.3	SCA Variable Number Registration or De-Registration	350
6.19.4	SCA Invocation with Call Accepted	350
6.19.5	SCA Invocation with Call Refused to Tone or Announcement	352
6.19.6	SCA Invocation with Call Refused to Voice Mail	353
6.19.7	SCA Invocation with Call Refused to Forward-To Number	354
6.20	Subscriber PIN Access	355
6.20.1	SPINA Variable Registration	355
6.20.2	SPINA Demand Activation or De-Activation	357
6.20.3	Call Origination with SPINA Active	359
6.20.4	Feature Request with SPINA Active	360
6.21	Subscriber PIN Intercept	361
6.21.1	SPINI Variable Registration	361
6.21.2	Call Origination with SPINI Active and Correct PIN Entered	363
6.21.3	Call Origination with SPINI Active and PIN Not Required	365
6.21.4	Call Origination with SPINI Active and Incorrect PIN Entered	366
6.21.5	Successful Call Origination with Local SPINI Operation	367
6.21.6	Unsuccessful Call Origination with Local SPINI Operation	368
6.22	Three-Way Calling	369
6.23	Voice Message Retrieval	369
6.23.1	Normal Operation: Invocation via Feature Code	369
6.23.2	Normal Operation: Invocation via Revertive Call	371
6.24	Voice Privacy	372
6.24.1	VP Profile Change	372
7	SHORT MESSAGE SERVICE SCENARIOS	373
7.1	Successful Short Message to a Known MS-Based SME	373
7.2	Short Message to a Denied MS-Based SME without Current Address	377
7.3	Short Message Time-Out to an MS-Based SME without Notification	379
7.4	Short Message Time-Out to an MS-Based SME with Notification	381
7.5	Short Message with Originating SMS Supplementary Services to an MS-Based SME	383
7.6	Short Message from an MS-Based SME to a Fixed SME	385
7.7	Short Message from an MS-Based SME with Originating SMS Supplementary Services to a Fixed SME	386
7.8	Successful Short Message Between Two MS-Based SMEs	387
7.9	Short Message Between Two MSs with Originating SMS Supplementary Services	388
7.10	Postponed SMSRequest without Current Address	391
7.11	Postponed SMDPP	393
7.12	Roaming Between SMS-Capable Systems with Pending Postponed Delivery	394
7.13	Roaming to an SMS-Incapable System with Pending Postponed Delivery	397

1
2
3
4
5
6
7
8
9
10
11
12
13
14
15
16
17
18
19
20
21
22
23
24
25
26
27
28
29
30
31
32
33
34
35
36
37
38
39
40
41
42
43
44
45
46
47
48
49
50
51
52
53
54
55
56
57
58
59
60

7.14	Roaming to an SMS-Capable System with Pending Postponed Delivery	398	
7.15	Local Roaming Between SMS-Capable Systems with Pending Postponed Delivery.....	400	
7.16	Local Roaming to an SMS-Incapable System with Pending Postponed Delivery.....	401	
7.17	Local Roaming to an SMS-Capable System with Pending Postponed Delivery.....	402	
7.18	MSC Deregistration with Pending Postponed Delivery	403	
7.19	VLR Deregistration with Pending Postponed Delivery.....	404	
7.20	Postponed MSC SMSNotification with Multiple SMDPPs.....	405	
7.21	Short Message Between MSC-Based SME and MS-Based SME.....	407	
7.22	Short Message Between HLR-Based SME and MS-Based SME	408	
7.23	Short Message Between MS and MC for MC-Based Feature Control.....	409	
7.24	Short Message to MS-Based SME After Handoff.....	410	
7.25	Short Message from MS-Based SME After Handoff.....	412	
Annex A (normative): Assumptions		414	
A.1.	Assumptions for MS Authentication	414	
A.2.	Assumptions for MS Signaling Message Encryption.....	415	
A.3.	Assumptions for MS Voice Privacy.....	416	
Annex J : A example of the information flows with Interconnection charge billing system.....		396	*
J.1.	Initial MS Registration in a New Serving System with Interconnection charge billing system	397	*
J.2.	CD Invocation to an Idle, Local MS with Interconnection charge billing system.....	399	*
J.3.	CD Invocation to an Idle MS on Another MSC with Interconnection charge billing system	401	*
J.4.	CFB Invocation with Interconnection charge billing system	403	*
J.5.	CFB Invocation with Call Collision and Interconnection charge billing system	405	*
J.6.	CFNA Invocation with No Answer or No Response Page with Interconnection charge billing system.....	409	*
J.7.	CFU Invocation with Interconnection charge billing system.....	413	*

LIST OF FIGURES

Figure 1	Initiate SSD Update (New SSD shared for SSD Update)	7
Figure 2	Initiate SSD Update (SSD not shared for SSD Update).....	9
Figure 3	Initiate CallHistoryCount Update.....	11
Figure 4	VLR-Initiated Unique Challenge.....	13
Figure 5	AC-Initiated Unique Challenge	14
Figure 6	Revocation of SSD Sharing	16
Figure 7	Successful AuthenticationDirectiveForward.....	17
Figure 8	Access Denied on Initial Registration.....	19
Figure 9	Successful Authentication on Initial Access	22
Figure 10	Failed Authentication on Initial Access	25
Figure 11	Successful Authentication on Call Origination (SSD not shared)	26
Figure 12	Successful Authentication on Call Termination (SSD not shared)	29
Figure 13	Initiate Authentication on Voice Channel (SSD not shared)	31
Figure 14	Successful Authentication on Call Origination (SSD shared)	33
Figure 15	Successful Authentication on Call Termination (SSD shared)	34
Figure 16	Initiate authentication on voice channel (SSD shared)	35
Figure 17	Report of AC-initiated action	37
Figure 18	Report of VLR-initiated action.....	40
Figure 19	Base Station Challenge with SSD not shared.....	42
Figure 20	Base Station Challenge with SSD shared.....	44
Figure 21	Successful BulkDeregistration.....	45
Figure 22	Successful CountRequest.....	46
Figure 23	Direct FeatureRequest without Call Routing	49
Figure 24	Direct FeatureRequest with Call Routing	51
Figure 25	Successful FlashRequest.....	53
Figure 26	Successful InformationDirective.....	55
Figure 27	Successful InformationForward.....	57
Figure 28	Successful InterSystemAnswer.....	59
Figure 29	Successful InterSystemPage: Border MSC Routing Information Returned.....	60
Figure 30	Unsuccessful InterSystemPage: Border MSC Access Denied.....	63
Figure 31	Unsuccessful InterSystemPage: Border MSC Resource Shortage.....	64
Figure 32	Successful InterSystemPage2: MS Presence Confirmed in Border MSC...	65
Figure 33	Unsuccessful InterSystemPage2: Access Denied.....	68
Figure 34	Unsuccessful InterSystemPage2: Resource Shortage.....	69
Figure 35	Successful InterSystemSetup.....	70
Figure 36	Unsuccessful InterSystemSetup.....	72

1
2
3
4
5
6
7
8
9
10
11
12
13
14
15
16
17
18
19
20
21
22
23
24
25
26
27
28
29
30
31
32
33
34
35
36
37
38
39
40
41
42
43
44
45
46
47
48
49
50
51
52
53
54
55
56
57
58
59
60

Figure 37	Successful LocationRequest: Route to a PSTN DN.....	74
Figure 38	Successful LocationRequest: Route to a Local MS.....	76
Figure 39	Successful LocationRequest: Route to an MS on Another MSC.....	77
Figure 40	Successful LocationRequest: Routing Information and Access Denied Indication Returned	78
Figure 41	Successful LocationRequest: Route to Multiple Terminations.....	79
Figure 42	Unsuccessful LocationRequest: Access Denied without Routing Information Returned	80
Figure 43	Successful MSInactive: MS Declared Inactive	83
Figure 44	Successful MSInactive: MS Deregistered.....	84
Figure 45	Successful OriginationRequest.....	86
Figure 46	Unsuccessful OriginationRequest.....	88
Figure 47	Successful QualificationDirective: Re-authorization Only	90
Figure 48	Successful QualificationDirective: Re-authorization and Update Profile...	92
Figure 49	Successful QualificationDirective: Update Profile Only.....	94
Figure 50	Successful QualificationDirective: De-authorization	95
Figure 51	Successful QualificationRequest: Authorization Confirmed.....	97
Figure 52	Successful QualificationRequest:.....	99
Figure 53	Successful QualificationRequest: Profile Returned Only.....	102
Figure 54	Unsuccessful QualificationRequest: Authorization Denied.....	103
Figure 55	Successful RandomVariableRequest.....	104
Figure 56	Unsuccessful RandomVariableRequest.....	105
Figure 57	Successful request	107
Figure 58	Unsuccessful request.....	108
Figure 59	Successful RedirectionRequest	110
Figure 60	Unsuccessful RedirectionRequest.....	111
Figure 61	Successful RegistrationCancellation: Single Access	113
Figure 62	Successful RegistrationCancellation: Multiple Access.....	115
Figure 63	Unsuccessful RegistrationCancellation: Multiple Access.....	117
Figure 64	Successful RegistrationNotification: Confirmed at the VLR.....	118
Figure 65	Successful RegistrationNotification: Confirmed at the HLR.....	122
Figure 66	Unsuccessful RegistrationNotification: Denied at the HLR.....	124
Figure 67	Successful RemoteUserInteractionDirective	127
Figure 68	Unsuccessful RemoteUserInteractionDirective.....	128
Figure 69	Successful Indirect RoutingRequest: TLDN Returned.....	130
Figure 70	Successful Direct RoutingRequest: TLDN Returned.....	133
Figure 71	Unsuccessful RoutingRequest: AccessDenied Returned	134
Figure 72	Successful SMSDeliveryBackward.....	136
Figure 73	Unsuccessful SMSDeliveryBackward.....	138
Figure 74	Successful SMSDeliveryForward.....	140

1
2
3
4
5
6
7
8
9
10
11
12
13
14
15
16
17
18
19
20
21
22
23
24
25
26
27
28
29
30
31
32
33
34
35
36
37
38
39
40
41
42
43
44
45
46
47
48
49
50
51
52
53
54
55
56
57
58
59
60

Figure 75	Unsuccessful SMSDeliveryForward.....	142
Figure 76	Successful SMSDeliveryPointToPoint.....	144
Figure 77	Unsuccessful SMSDeliveryPointToPoint.....	146
Figure 78	Successful SMSNotification: MS-Based SME Availability Report.....	147
Figure 79	Successful SMSNotification: MS-Based SME Unavailability Report.....	148
Figure 80	Successful SMSRequest: MS-Based SME Address Request	150
Figure 81	Unsuccessful SMSRequest: MS-Based SME Address Request.....	151
Figure 82	Successful TransferToNumberRequest.....	153
Figure 83	Unsuccessful TransferToNumberRequest: Access Denied.....	156
Figure 84	Successful UnreliableRoamerDataDirective.....	157
Figure 85	Successful UnsolicitedResponse.....	158
Figure 86	Unsuccessful UnsolicitedResponse with Return Result.....	161
Figure 87	Initial MS Registration in a New Serving System	163
Figure 88	Multiple Registrations with Cancellation Denied at the VLR	165
Figure 89	MS Deregistered by Serving MSC.....	167
Figure 90	MS Deregistered by Serving VLR.....	168
Figure 91	Registered MS Declared Inactive by Serving MSC.....	169
Figure 92	MS Declared Inactive by Serving MSC at Registration.....	170
Figure 93	Initial Registration with Authentication	173
Figure 94	Origination with Authentication	175
Figure 95	Termination with Authentication	178
Figure 96	Authentication on Voice Channel.....	181
Figure 97	Authentication on Flash Request.....	183
Figure 98	SSD Update When SSD is Not Shared.....	186
Figure 99	AC Initiated CallHistoryCount Update with SSD Not Shared.....	189
Figure 100	Authentication When SSD is Currently Shared with Another System	191
Figure 101	SSD Update When SSD is Shared.....	193
Figure 102	AC Initiated Unique Challenge	196
Figure 103	VLR Initiated Unique Challenge When SSD is Shared.....	198
Figure 104	RegistrationCancellation with CallHistoryCount Report.....	200
Figure 105	Feature Request Confirmation with Release	202
Figure 106	Feature Request Confirmation with Call Routing	204
Figure 107	Feature Request Denial with Call Release	205
Figure 108	Feature Request After Handoff.....	206
Figure 109	Service Provider MWN Profile Change.....	208
Figure 110	Call Origination without Profile	209
Figure 111	Call Termination or Message Delivery without Profile	210
Figure 112	Feature Registration with SPINI Active.....	211
Figure 113	Recovery from data failure at the HLR.....	213

1
2
3
4
5
6
7
8
9
10
11
12
13
14
15
16
17
18
19
20
21
22
23
24
25
26
27
28
29
30
31
32
33
34
35
36
37
38
39
40
41
42
43
44
45
46
47
48
49
50
51
52
53
54
55
56
57
58
59
60

Figure 114	CD Invocation to an Idle MS on Another MSC	216
Figure 115	CD Invocation to an Idle, Local MS.....	218
Figure 116	CD Invocation to a Busy MS	219
Figure 117	CD Invocation with No Page Response or No Answer.....	220
Figure 118	CD Invocation to an Inaccessible MS.....	221
Figure 119	CD Invocation with Intersystem Paging	223
Figure 120	CD Invocation with Unsolicited Page Response.....	226
Figure 121	TLDN Call Arrival with Intersystem Paging	228
Figure 122	TLDN Call Arrival with No Page Response to Intersystem Paging.....	230
Figure 123	TLDN Call Arrival with No Answer After Paging, Call Release Initiated by Serving MSC	231
Figure 124	TLDN Call Arrival with No Answer After Intersystem Paging, Call Release Initiated by Border MSC.....	233
Figure 125	Origination in a Neighboring System	235
Figure 126	CFB Invocation.....	238
Figure 127	CFB Invocation with Call Collision	239
Figure 128	CFD Invocation (Immediate).....	242
Figure 129	CFD Invocation with No Answer or No Response to Page.....	243
Figure 130	CFU Invocation with Alert	248
Figure 131	CW Demand Cancellation with Call	250
Figure 132	CW Demand Cancellation (during call).....	252
Figure 133	CW Invocation.....	253
Figure 134	CW Interaction After Handoff.....	255
Figure 135	CNIP Invocation to an Idle Subscriber	257
Figure 136	CNIP Interaction with CW.....	259
Figure 137	CNIP Interaction with Call Waiting After Handoff	261
Figure 138	CNIP Interaction with CFU.....	263
Figure 139	CNIP Interaction with CFU After Handoff.....	265
Figure 140	CNIR Temporary Activation or De-Activation with Call.....	266
Figure 141	CNIR Interaction with CFU.....	268
Figure 142	CNIR Interaction with CFNA or CFD on MS No Answer	270
Figure 143	CNIR Interaction with CFB or CFD on MS Busy.....	273
Figure 144	CNIR Interaction with CFB or CFD on Call Collision.....	275
Figure 145	CC Invocation with Call Setup Request.....	277
Figure 146	CC Add Party (Without Feature Code Entry).....	279
Figure 147	CC Invocation During a Call	281
Figure 148	CC Drop Last Party Invocation	283
Figure 149	DND Invocation.....	285
Figure 150	DND Interaction with CFU.....	286
Figure 151	FA Invocation	288

1
2
3
4
5
6
7
8
9
10
11
12
13
14
15
16
17
18
19
20
21
22
23
24
25
26
27
28
29
30
31
32
33
34
35
36
37
38
39
40
41
42
43
44
45
46
47
48
49
50
51
52
53
54
55
56
57
58
59
60

Figure 152	FA Invocation with a Busy FA Group Member (Single-User Type).....	291
Figure 153	FA Invocation with a Busy FA Group Member (Multiple-User Type).....	293
Figure 154	FA Interaction with CFNA on FA Group Member.....	295
Figure 155	FA Invocation with a No Answer FA Group Member with Group Redirection.....	298
Figure 156	FA Invocation on Revertive Call to FA Pilot DN.....	300
Figure 157	FA Invocation on Call from FA Group Member.....	303
Figure 158	Temporary De-Activation of MWN PIP Tone (with call setup)	306
Figure 159	MWN via Alert Pip Tone.....	308
Figure 160	MWN via an MS Indication and/or MS Count	310
Figure 161	MWN After Handoff.....	311
Figure 162	MWN via Pip Tone on MS Call Origination.....	313
Figure 163	MWN via Pip Tone on MS Termination.....	314
Figure 164	MAH Invocation	316
Figure 165	MAH Invocation with a Busy MAH Group Member.....	320
Figure 166	MAH Invocation with a Busy MAH Group Member.....	322
Figure 167	MAH Invocation with a No Answer MAH Group Member.....	324
Figure 168	MAH Invocation on Revertive Call to MAH Pilot DN.....	328
Figure 169	MAH Invocation on Call from MAH Group Member.....	330
Figure 170	PCA Invocation with Call Accepted.....	334
Figure 171	PCA Invocation with Call Accepted: Alternate Procedure	336
Figure 172	PCA Invocation with Call Refused to Tone or Announcement.....	338
Figure 173	PCA Invocation with Call Refused to Voice Mail.....	339
Figure 174	PCA Invocation with Call Refused to Forward-To Number.....	340
Figure 175	PL Registration (variable option)	341
Figure 176	Successful PACA Activation.....	343
Figure 177	Aborted PACA Activation.....	345
Figure 178	Unsuccessful PACA Activation with Call	346
Figure 179	Typical RFC Transaction Sequence	348
Figure 180	SCA Invocation with Call Accepted.....	350
Figure 181	SCA Invocation with Call Refused to Tone or Announcement.....	352
Figure 182	SCA Invocation with Call Refused to Voice Mail.....	353
Figure 183	SCA Invocation with Call Refused to Forward-To Number.....	354
Figure 184	SPINA Variable Registration	355
Figure 185	SPINA Demand Activation or De-Activation.....	357
Figure 186	Call Origination with SPINA Active.....	359
Figure 187	Feature Request with SPINA Active.....	360
Figure 188	SPINI Variable Registration	361
Figure 189	Call Origination with SPINI Active and Correct PIN Entered	363
Figure 190	Call Origination with SPINI Active and PIN Not Required.....	365

1
2
3
4
5
6
7
8
9
10
11
12
13
14
15
16
17
18
19
20
21
22
23
24
25
26
27
28
29
30
31
32
33
34
35
36
37
38
39
40
41
42
43
44
45
46
47
48
49
50
51
52
53
54
55
56
57
58
59
60

Figure 191	Call Origination with SPINI Active and Incorrect PIN Entered	366
Figure 192	Successful Call Origination with Local SPINI Operation.....	367
Figure 193	Unsuccessful Call Origination with Local SPINI Operation.....	368
Figure 194	Normal Operation: Invocation via Feature Code.....	369
Figure 195	Normal Operation: Invocation via Revertive Call.....	371
Figure 196	VP Profile Change.....	372
Figure 197	Successful Short Message from a Fixed SME to a Known MS-Based SME.....	374
Figure 198	Short Message from a Fixed SME to a Denied MS-Based SME without Current Address.....	377
Figure 199	Short Message Time-Out to an MS-Based SME without Notification	379
Figure 200	Short Message Time-Out to an MS-Based SME with Notification	381
Figure 201	Short Message from a Fixed SME with Originating Supplementary Services to an Active MS-Based SME	383
Figure 202	Short Message from an MS-Based SME to a Fixed SME.....	385
Figure 203	Short Message from an MS-Based SME with Originating SMS Supplementary Services to a Fixed SME.....	386
Figure 204	Successful Short Message Between Two MS-Based SMEs.....	387
Figure 205	Short Message Between Two MS-Based SMEs with Originating SMS Supplementary Services.....	389
Figure 206	Postponed SMSRequest without Current Address.....	391
Figure 207	Postponed SMDPP	393
Figure 208	Roaming Between SMS-Capable Systems with Postponed Delivery.....	395
Figure 209	Roaming to an SMS-Incapable System with Pending Postponed Delivery	397
Figure 210	Roaming to an SMS-Capable System with Pending Postponed Delivery.....	398
Figure 211	Local Roaming Between SMS-Capable Systems with Pending Postponed Delivery.....	400
Figure 212	Local Roaming to an SMS-Incapable System with Pending Postponed Delivery	401
Figure 213	Local Roaming to an SMS-Capable System with Pending Postponed Delivery	402
Figure 214	MSC Deregistration with Pending Postponed Delivery.....	403
Figure 215	VLR Deregistration with Pending Postponed Delivery	404
Figure 216	Postponed MSC SMSNotification with Multiple SMDPPs.....	405
Figure 217	Short Message Between MSC-Based SME and MS-Based SME	407
Figure 218	Short Message Between HLR Based SME and MS-Based SME	408
Figure 219	Short Message Between MS-Based SME and MC for MC-Based Feature Control.....	409
Figure 220	Short Message to MS-Based SME After Handoff.....	410
Figure 221	Short Message from MS-Based SME After Handoff.....	412

1
2
3
4
5
6
7
8
9
10
11
12
13
14
15
16
17
18
19
20
21
22
23
24
25
26
27
28
29
30
31
32
33
34
35
36
37
38
39
40
41
42
43
44
45
46
47
48
49
50
51
52
53
54
55
56
57
58
59
60

Figure J.1	Initial MS Registration in a New Serving System with Interconnection charge billing system	397	*
Figure J.2	CD Invocation to an Idle, Local MS with Interconnection charge billing system.....	399	*
Figure J.3	CD Invocation to an Idle MS on Another MSC with Interconnection charge billing system	401	*
Figure J.4	CFB Invocation with Interconnection charge billing system	403	*
Figure J.5	CFB Invocation with Call Collision and Interconnection charge billing system.....	406	*
Figure J.6	CFNA Invocation with No Answer or No Response Page with Interconnection charge billing system	410	*
Figure J.7	CFU Invocation with Interconnection charge billing system	413	*

1
2
3
4
5
6
7
8
9
10
11
12
13
14
15
16
17
18
19
20
21
22
23
24
25
26
27
28
29
30
31
32
33
34
35
36
37
38
39
40
41
42
43
44
45
46
47
48
49
50
51
52
53
54
55
56
57
58
59
60

LIST OF TABLES

Table 1	Operation Component and Timer Acronyms	3
Table 2	FE Combinations for AUTHDIR.....	6
Table 3	FE Combinations for AUTHDIRFWD.....	17
Table 4	FE Combinations for AFREPORT.....	19
Table 5	FE Combinations for AUTHREQ.....	21
Table 6	FE Combinations for ASREPORT.....	36
Table 7	FE Combinations for BSCHALL.....	41
Table 8	FE Combination for BULKDEREG.....	45
Table 9	FE Combinations for COUNTREQ.....	46
Table 10	FE Combinations for FEATREQ.....	48
Table 11	FE Combinations for FLASHREQ.....	53
Table 12	FE Combinations for INFODIR.....	55
Table 13	FE Combinations for INFOFWD.....	57
Table 14	FE Combinations for ISANSWER.....	59
Table 15	FE Combinations for ISPAGE.....	60
Table 16	FE Combinations for ISPAGE2.....	65
Table 17	FE Combinations for ISSETUP.....	70
Table 18	FE Combinations for LOCREQ.....	73
Table 19	FE Combinations for MSINACT.....	82
Table 20	FE Combinations for ORREQ.....	86
Table 21	FE Combinations for QUALDIR.....	89
Table 22	FE Combinations for QUALREQ.....	97
Table 23	FE Combinations for RANDREQ.....	104
Table 24	FE Combinations for REDDIR.....	106
Table 25	FE Combinations for REDREQ.....	109
Table 26	FE Combinations for REGCANC.....	112
Table 27	FE Combinations for REGNOT.....	118
Table 28	FE Combinations for RUIDIR.....	127
Table 29	FE Combinations for ROUTREQ.....	129
Table 30	FE Combinations for SMDBACK.....	135
Table 31	FE Combinations for SMDFWD.....	139
Table 32	FE Combinations for SMDPP.....	143
Table 33	FE Combinations for SMSNOT.....	147
Table 34	FE Combinations for SMSREQ.....	149
Table 35	FE Combinations for TRANUMREQ.....	153
Table 36	FE Combinations for UNRELDIR.....	157
Table 37	FE Combinations for UNSOLRESP.....	158

FOREWORD

This is one of a series of recommendations entitled:

“Cellular Radiotelecommunications Intersystem Operations”

which describe procedures necessary to provide to cellular radio telephone subscribers certain services requiring interaction between different cellular systems.

It is the intention of TIA/EIA TR-45.2 Subcommittee, Intersystem Operations, that this series of recommendations address the ongoing and developing concerns of the Cellular Radiotelecommunications Industry— subscribers, service providers and manufacturers alike— with regard to useful and effective services requiring standardized intersystem procedures.

The recommendations included in this series are:

- Chapter 1, *Cellular Radiotelecommunications Intersystem Operations: Functional Overview*
- Chapter 2, *Cellular Radiotelecommunications Intersystem Operations: Intersystem Handoff Information Flows*
- Chapter 3, *Cellular Radiotelecommunications Intersystem Operations: Automatic Roaming Information Flows*
- Chapter 4, *Cellular Radiotelecommunications Intersystem Operations: Operations, Administration, and Maintenance Information Flows and Procedures*
- Chapter 5, *Cellular Radiotelecommunications Intersystem Operations: Signaling Protocols*
- Chapter 6, *Cellular Radiotelecommunications Intersystem Operations: Signaling Procedures*

This edition of the Standard replaces *IS-41-C* which differs from the previous edition (i.e., *IS-41-B*) in its support of the following functionality:

- Intersystem Authentication and Encryption (supersedes *TSB51*)
- Intersystem Operations for Dual-mode CDMA Terminals (supersedes *TSB64*)
- Border Cell Problem Resolution (supersedes *TSB65*)
- Expanded Feature Support (i.e., for features defined in *IS-53-A*)
- Technical Clarifications and Compatibility (as per *TSB41* and *TSB55*)

1
2
3
4
5
6
7
8
9
10
11
12
13
14
15
16
17
18
19
20
21
22
23
24
25
26
27
28
29
30
31
32
33
34
35
36
37
38
39
40
41
42
43
44
45
46
47
48
49
50
51
52
53
54
55
56
57
58
59
60

REVISION HISTORY

Revision	Date	Remarks
<i>(IS-41) 0</i>	February 1988	Initial publication
<i>(IS-41) A</i>	January 1991	
<i>(IS-41) B</i>	December 1991	
<i>(IS-41) C</i>	November 1995	
D	December 1997	Initial ANSI publication

NOTE

The Numbering system of this series of Standards varies from normal EIA/TIA practice. The unique numbering system assigned to these documents is intended to reflect their hierarchical structure.

1 INTRODUCTION

1.1 OBJECTIVE

This document presents the recommendations by which a roaming cellular subscriber may be provided with "Automatic Roaming" as defined to comprise the following mechanisms:

- 1) Making the identity of the current serving, or visited system known to the home system.
- 2) Establishing financial responsibility for the roaming subscriber.
- 3) Establishing a valid roamer service profile in a visited system.
- 4) Providing for call delivery to the roaming subscriber.

The transactions are automatic in the sense that they operate in a manner that requires minimal intervention on the part of both the cellular subscriber and parties attempting to place a call to a cellular subscriber.

1.2 SCOPE

This document defines automatic roaming by describing the information flows between functional entities which occur in a number of automatic roaming scenarios.

Rather than taking an abstract approach, this document uses the information flows captured in the messages, parameters, and procedures defined in *IS-41-B* as its starting point. Additional information flows are specified in order to meet the requirements associated with the support of the features in *TIA/EIA-664*.

The detailed encoding of the signaling messages and parameters which are derived from the information flows in this document are specified in *TIA/EIA-41* Chapter 5.

The detailed definition of the functional entity procedures associated with the information flows in this document are specified in *TIA/EIA-41* Chapter 6.

1.3 ORGANIZATION

This document is organized as follows:

- Section 1, entitled “Introduction,” provides introductory information for this Standard.
- Section 2, entitled “References,” lists the normative and informative references for this Standard.
- Section 3, entitled “Terminology,” lists the definitions, symbols, abbreviations, and other documentation conventions used in this Standard.
- Section 4, entitled “Automatic Roaming Operations,” defines the set of *TIA/EIA-41* automatic roaming operations in terms of the interactions between network functional entities (FEs) involved in the support of the operations’ capabilities. Operations are the *building blocks* used to construct the more complex information flows specified in Sections 5, 6, and 7.
- Section 5, entitled “Basic Automatic Roaming Scenarios,” depicts the interactions between FEs in various situations related to the support of basic automatic roaming functionality, (i.e., registration, deregistration, MS inactivity reporting, authentication, basic feature processing, and automatic roaming maintenance).
- Section 6, entitled “Voice Feature Scenarios,” depicts the interactions between FEs in various situations related to *IS-53-A* voice feature support under automatic roaming conditions.
- Section 7, entitled “Short Message Service Scenarios,” depicts the interactions between FEs in various situations related to the support of *IS-53-A* Short Message Services under automatic roaming conditions.

2 REFERENCES

Refer to Chapter 1.

3 TERMINOLOGY

3.1 DEFINITIONS

Refer to Chapter 1.

3.2 SYMBOLS AND ABBREVIATIONS

Refer to Chapter 1.

Throughout this Standard, the operation component acronyms listed in the following table are used. The acronyms for the operation timers (i.e., the timer that runs between the sending of an operation INVOKE component and the receipt of the operation response) are also listed.

Table 1 Operation Component and Timer Acronyms

Operation Name	INVOKE Component Acronym	RETURN RESULT Component Acronym	Operation Timer Acronym
AuthenticationDirective	AUTHDI R	authdi r	ADT
AuthenticationDirectiveForward	AUTHDI RFWD	authdi rfwd	ADFT
AuthenticationFailureReport	AFREPORT	afreport	AFT
AuthenticationRequest	AUTHREQ	authreq	ART
AuthenticationStatusReport	ASREPORT	asreport	ASRRT
BaseStationChallenge	BSCHALL	bschal l	BSCT
Blocking	BLOCKI NG	bl ocki ng	BLKT
BulkDeregistration	BULKDEREG	bul kdereg	BDRT
CountRequest	COUNTREQ	countreq	CRT
FacilitiesDirective	FACDI R	facdi r	HOT
FacilitiesDirective2	FACDI R2	facdi r2	HOT
FacilitiesRelease	FACREL	facrel	CTT
FeatureRequest	FEATREQ	featreq	FRRT
FlashRequest	FLASHREQ	fl ashreq	FRT
HandoffBack	HANDBACK	handback	HOT
HandoffBack2	HANDBACK2	handback2	HOT
HandoffMeasurementRequest	HANDMREQ	handmreq	LMMRT
HandoffMeasurementRequest2	HANDMREQ2	handmreq2	LMMRT
HandoffToThird	HANDTHI RD	handthi rd	HTTT
HandoffToThird2	HANDTHI RD2	handthi rd2	HTTT
InformationDirective	I NFODI R	i nfodi r	I DT
InformationForward	I NFOFWD	i nfofwd	I FT

Table 1 (concluded)

Operation Name	INVOKE Component Acronym	RETURN RESULT Component Acronym	Operation Timer Acronym
InterSystemAnswer	I SANSWER	i sanswer	I SAT
InterSystemPage	I SPAGE	i spage	I SPRT
InterSystemPage2	I SPAGE2	i spage2	I SPRT
InterSystemSetup	I SSETUP	i ssetup	I SSRT
LocationRequest	LOCREQ	l ocreq	LRT
MobileOnChannel	MSONCH	none	none
MSInactive	MSI NACT	msi nact	MSI T
OriginationRequest	ORREQ	orreq	ORT
QualificationDirective	QUALDI R	qual di r	QDT
QualificationRequest	QUALREQ	qual req	QRT
RandomVariableRequest	RANDREQ	randreq	RANDRT
RedirectionDirective	REDDI R	reddi r	RDT
RedirectionRequest	REDREQ	redreq	RDRT
RegistrationCancellation	REGCANC	regcanc	RCT
RegistrationNotification	REGNOT	regnot	RNT
RemoteUserInteractionDirective	RUI DI R	rui di r	RU DT
ResetCircuit	RESETCKT	resetckt	RSTT
RoutingRequest	ROUTREQ	routreq	RRT
SMSDeliveryBackward	SMDBACK	smdback	SBT
SMSDeliveryForward	SMDFWD	smdfwd	SFT
SMSDeliveryPointToPoint	SMDPP	smdpp	SPT
SMSNotification	SMSNOT	smsnot	SNT
SMSRequest	SMSREQ	smsreq	SRT
TransferToNumberRequest	TRANUMREQ	tr anumreq	TTNRT
TrunkTest	TTEST	ttest	TTT
TrunkTestDisconnect	TTESTDI SC	ttestdi sc	TTDT
Unblocking	UNBLOCKI NG	unbl ocki ng	UBLKT
UnreliableRoamerDataDirective	UNRELDI R	unrel di r	URDDT
UnsolicitedResponse	UNSOLRES	unsol res	URT

1
2
3
4
5
6
7
8
9
10
11
12
13
14
15
16
17
18
19
20
21
22
23
24
25
26
27
28
29
30
31
32
33
34
35
36
37
38
39
40
41
42
43
44
45
46
47
48
49
50
51
52
53
54
55
56
57
58
59
60

3.3 DOCUMENTATION CONVENTIONS

Refer to Chapter 1.

4 AUTOMATIC ROAMING OPERATIONS

Operations are the *building blocks* used to construct the more complex information flows specified in Sections 5, 6, and 7. This section defines the *TIA/EIA-41* automatic roaming operations in terms of the interactions between functional entities (FEs) involved in the support of the operations' capabilities. Please note that the building blocks in this section do not include a complete listing of operation parameters, either in the figures or in the accompanying text description. Parameters are included where they are deemed necessary to improve the understanding of the building block. For a complete description of the parameters associated with each operation, refer to *TIA/EIA-41* Chapter 5.

The operation usage scenarios shown throughout this section are for illustrative purposes only.

4.1 AuthenticationDirective

The AuthenticationDirective (AUTHDIR) operation is used to request modification of an MS's authentication parameters.

The following table lists the valid combinations of invoking and responding FEs.

Table 2 FE Combinations for AUTHDIR

	INVOKING FE	RESPONDING FE
Case 1	AC	HLR
Case 2	HLR	Serving VLR
Case 3	Serving VLR	Serving MSC

The AuthenticationDirective operation allows one or more of several possible authentication processes to be initiated:

1. An update of SharedSecretData (SSD) when SSD is shared.
2. An update of SSD when SSD is not shared.
3. An update of the CallHistoryCount (COUNT) parameter value.
4. A Unique Challenge when SSD is shared (i.e., VLR-initiated).
5. A Unique Challenge when SSD is not shared (i.e., AC-initiated).
6. Revocation of SSD sharing.

These operation scenarios are illustrated in Sections 4.1.1 through 4.1.6, respectively.

4.1.1 Initiate SSD Update (New SSD shared for SSD Update)

This operation scenario describes the use of the AuthenticationDirective operation to initiate a SSD update process when SSD is shared.

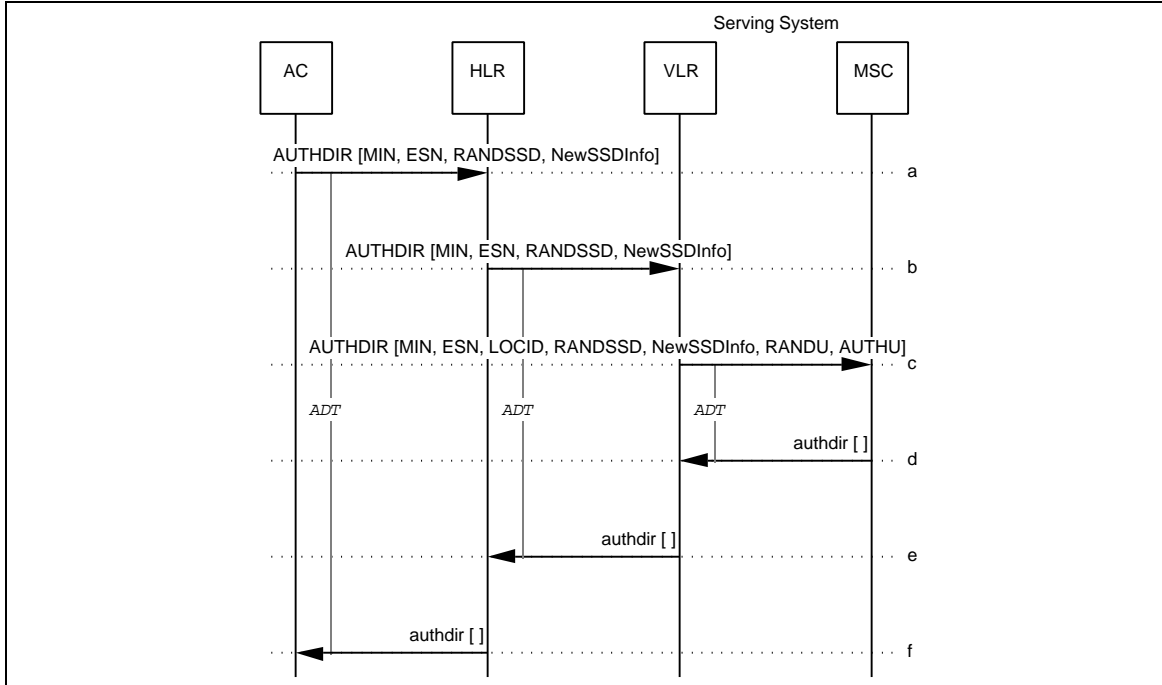

Figure 1 Initiate SSD Update (New SSD shared for SSD Update)

- a. The AC determines that the SSD in the MS must be updated. The AC sends an AUTHDIR to the HLR associated with the MS.

Parameters	Usage	Type
MIN	Served MS MIN.	R
ESN	Served MS ESN.	R
RANDSSD	Random number generated by AC to produce new SSD.	R
NewSSDInfo:	New SSD information:	
[Authentication-AlgorithmVersion]	Include to select authentication algorithm other than default.	O
[SSD]	Pending value of VLR and AC shared secret data for SSD Update.	R

- b. The HLR forwards the AUTHDIR to the VLR currently serving the identified MS. Parameters are as in Step-a.
- c. The Serving VLR sends an AUTHDIR to the Serving MSC.

Parameters are as in Step-a, with the following additions:

Parameters	Usage	Type
LOCID	Location Area ID. Include if available.	O
RANDU	Random number generated by VLR to produce AUTHU.	R
AUTHU	Expected MS response to Unique Challenge Order as calculated by VLR.	R

- d. The Serving MSC returns an empty `authdir` to the Serving VLR to indicate that the directive has been accepted. Confirmation that SSD updating has been attempted or completed is provided later since the MSC may not be able to initiate the SSD update air interface procedure at this time.
- e. The Serving VLR forwards the `authdir` to the HLR.
- f. The HLR forwards the `authdir` to the AC.

4.1.2 Initiate SSD Update (SSD not shared for SSD Update)

This operation scenario describes the use of the AuthenticationDirective operation to initiate a SSD update process when SSD is not shared.

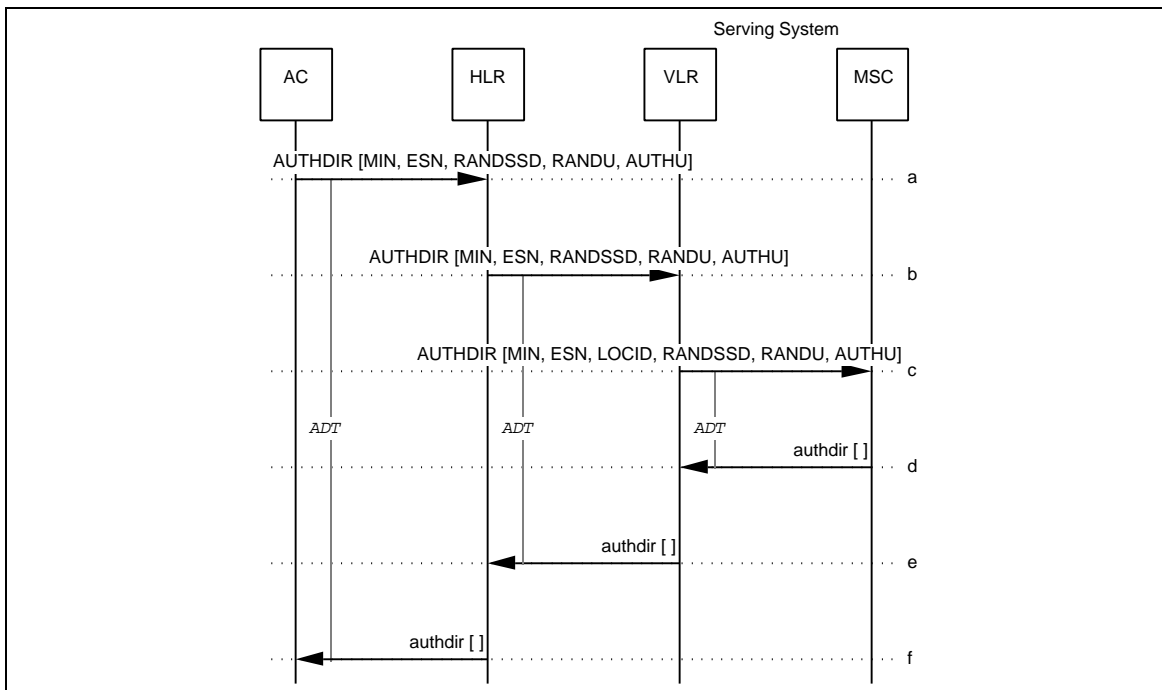

Figure 2 Initiate SSD Update (SSD not shared for SSD Update)

1
2
3
4
5
6
7
8
9
10
11
12
13
14
15
16
17
18
19
20
21
22
23
24
25
26
27
28
29
30
31
32
33
34
35
36
37
38
39
40
41
42
43
44
45
46
47
48
49
50
51
52
53
54
55
56
57
58
59
60

- a. The AC determines that the SSD in the MS must be updated. The AC sends an AUTHDI R to the HLR associated with the MS.

Parameters	Usage	Type
MIN	Served MS MIN.	R
ESN	Served MS ESN.	R
RANDSSD	Random number generated by AC to produce new SSD.	R
RANDU	Random number generated by AC to produce AUTHU.	R
AUTHU	Expected MS response to Unique Challenge Order as calculated by AC.	R

- b. The HLR forwards the AUTHDI R to the VLR currently serving the identified MS. Parameters are as in Step-a.
- c. The Serving VLR forwards the AUTHDI R to the Serving MSC.

Parameters are as in Step-a, with the exception that the NOSSD parameter is not sent and with the following addition:		
Parameters	Usage	Type
LOCID	Location Area ID. Include if available.	O

- d. The Serving MSC returns an empty authdi r to the Serving VLR to indicate that the directive has been accepted. Confirmation that SSD updating has been attempted or completed is provided later since the MSC may not be able to initiate the SSD update air interface procedure at this time.
- e. The Serving VLR forwards the authdi r to the HLR.
- f. The HLR forwards the authdi r to the AC.

4.1.3 Initiate CallHistoryCount Update

This operation scenario describes the use of the AuthenticationDirective operation to initiate a CallHistoryCount (COUNT) update process.

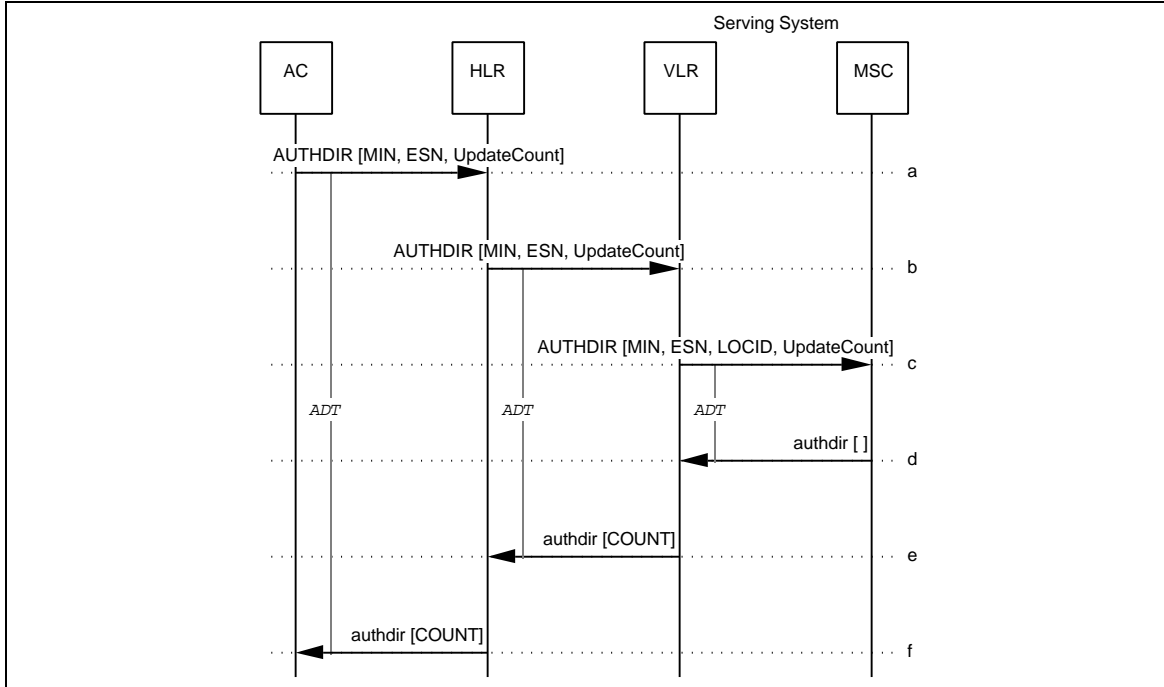

Figure 3 Initiate CallHistoryCount Update

- 1
2
3
4
5
6
7
8
9
10
11
12
- a. The AC determines that the CallHistoryCount (COUNT) in the MS must be updated. The AC sends an AUTHDI R to the HLR associated with the MS.

Parameters	Usage	Type
MIN	Served MS MIN.	R
ESN	Served MS ESN.	R
UpdateCount	Indicates that the CallHistoryCount update procedure shall be initiated.	R

- 13
14
15
16
- b. The HLR forwards the AUTHDI R to the VLR currently serving the identified MS. Parameters are as in Step-a.

- c. The Serving VLR forwards the AUTHDI R to the Serving MSC.

17
18
19
20
21
22

Parameters are as in Step-a, with the following addition:		
Parameters	Usage	Type
LOCID	Location Area ID. Include if available.	O

- 23
24
25
26
- d. The Serving MSC returns an empty `authdi r` to the Serving VLR to indicate that the directive has been accepted. Confirmation that COUNT updating has been attempted or completed is provided later since the Serving MSC may not be able to initiate the COUNT update air interface procedure at this time.

- 27
28
- e. The Serving VLR forwards the `authdi r` to the HLR.

29
30
31
32
33

Parameters	Usage	Type
COUNT	Value of event counter used for clone detection as stored at VLR. Include if SSD is shared with the VLR and COUNT is available.	O

- 34
35
36
37
38
39
40
41
42
43
44
45
46
47
48
49
50
51
52
53
54
55
56
57
58
59
60
- f. The HLR forwards the `authdi r` to the AC. Parameters are as in Step-e.

1
2
3
4 **4.1.4 VLR-Initiated Unique Challenge**

5
6 This operation scenario describes the use of the AuthenticationDirective operation to initiate
7 a Unique Challenge process when SSD is shared.

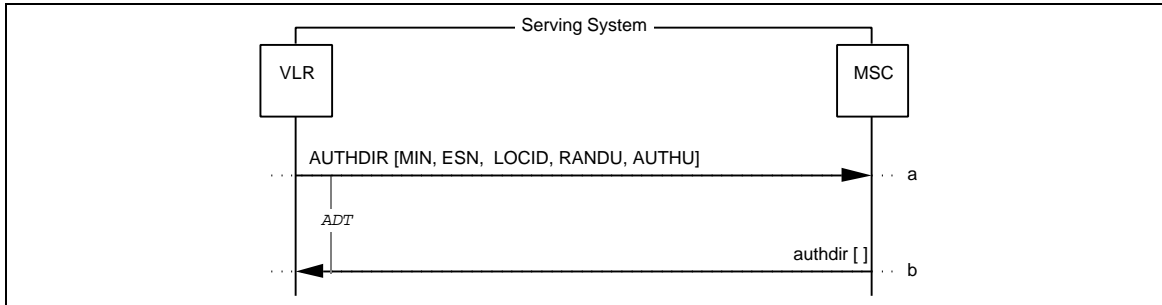

19
20 **Figure 4 VLR-Initiated Unique Challenge**

- 21
22 a. The Serving VLR sends an AUTHDIR to the Serving MSC.

23

Parameters	Usage	Type
MIN	Served MS MIN.	R
ESN	Served MS ESN.	R
LOCID	Location Area ID. Include if available.	O
RANDU	Random number generated by VLR to produce AUTHU.	R
AUTHU	Expected MS response to Unique Challenge Order as calculated by VLR.	R

- 24
25
26
27
28
29
30
31
32
33
34
35 b. The Serving MSC returns an empty authdir to the Serving VLR to indicate that the
36 directive has been accepted. Confirmation that the Unique Challenge has been
37 attempted or completed is provided later since the MSC may not be able to initiate the
38 Unique Challenge air interface procedure at this time.
39
40
41
42
43
44
45
46
47
48
49
50
51
52
53
54
55
56
57
58
59
60

4.1.5 AC-Initiated Unique Challenge

This operation scenario describes the use of the AuthenticationDirective operation to initiate a Unique Challenge process when SSD is not shared.

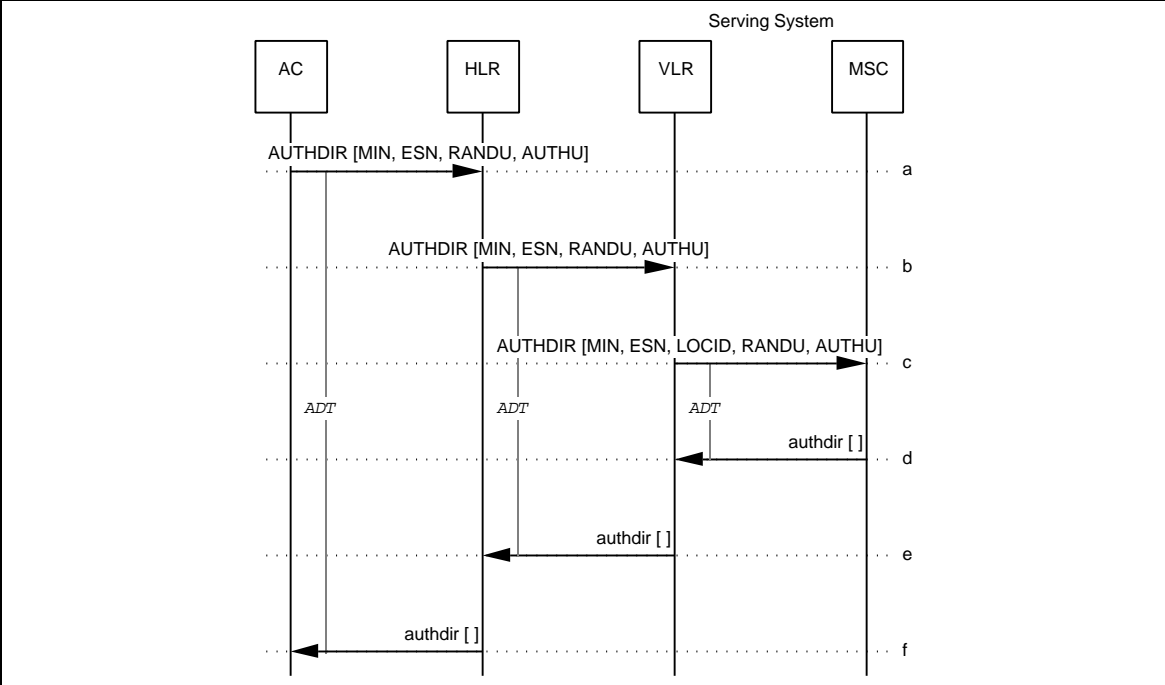

Figure 5 AC-Initiated Unique Challenge

1
2
3
4
5
6
7
8
9
10
11
12
13
14
15
16
17
18
19
20
21
22
23
24
25
26
27
28
29
30
31
32
33
34
35
36
37
38
39
40
41
42
43
44
45
46
47
48
49
50
51
52
53
54
55
56
57
58
59
60

1
2
3
4
5
6
7
8
9
10
11
12
13
14
15
16
17
18
19
20
21
22
23
24
25
26
27
28
29
30
31
32
33
34
35
36
37
38
39
40
41
42
43
44
45
46
47
48
49
50
51
52
53
54
55
56
57
58
59
60

- a. The AC sends an AUTHDI R to the HLR associated with the MS.

Parameters	Usage	Type
MIN	Served MS MIN.	R
ESN	Served MS ESN.	R
RANDU	Random number generated by AC to produce AUTHU.	R
AUTHU	Expected MS response to Unique Challenge Order as calculated by AC.	R

- b. The HLR forwards the AUTHDI R to the VLR currently serving the identified MS. Parameters are as in Step-a.

- c. The Serving VLR forwards the AUTHDI R to the Serving MSC.

Parameters are as in Step-a, with the following addition:		
Parameters	Usage	Type
LOCID	Location Area ID. Include if available.	O

- d. The Serving MSC returns an empty authdi r to the Serving VLR to indicate that the directive has been accepted. Confirmation that the Unique Challenge has been attempted or completed is provided later since the MSC may not be able to initiate the Unique Challenge air interface procedure at this time.
- e. The Serving VLR forwards the authdi r to the HLR.
- f. The HLR forwards the authdi r to the AC.

4.1.6 Revocation of SSD Sharing

This operation scenario describes the use of the AuthenticationDirective operation to revoke SSD sharing.

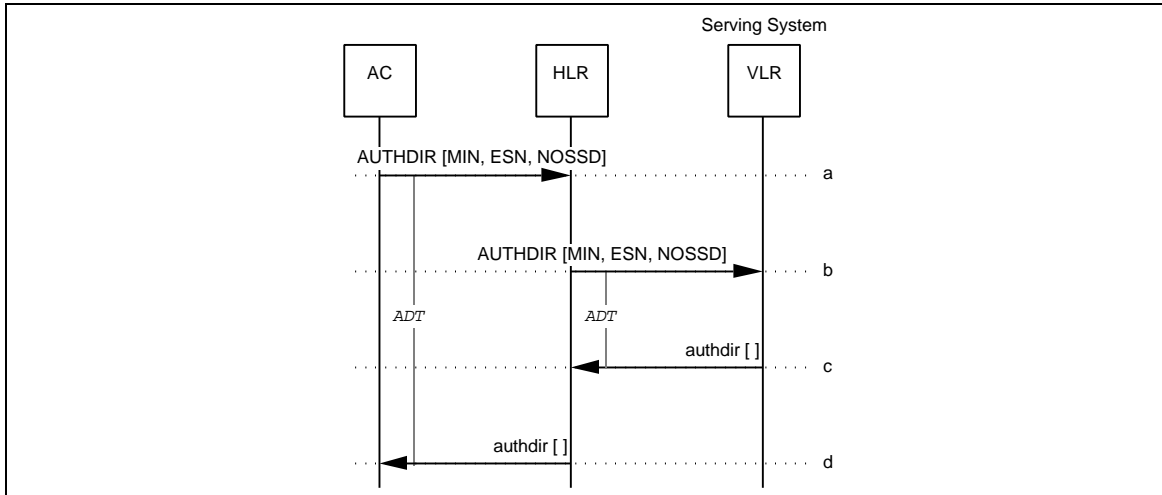

Figure 6 Revocation of SSD Sharing

- a. The AC sends an AUTHDIR to the HLR associated with the MS.

Parameters	Usage	Type
MIN	Served MS MIN.	R
ESN	Served MS ESN.	R
NOSSD	Indicates that previously provided SSD is no longer valid and should be discarded.	R

- b. The HLR forwards the AUTHDIR to the VLR currently serving the identified MS. Parameters are as in Step-a.
- c. The Serving VLR discards the current value of the SSD and returns an empty authdir to the HLR to indicate that the revocation has been accepted.
- d. The HLR forwards the authdir to the AC.

4.2 AuthenticationDirectiveForward

The AuthenticationDirectiveForward (AUTHDIRFWD) operation is used by the Anchor MSC to request the Serving MSC to initiate a Unique Challenge to the indicated MS.

The following table lists the valid combinations of invoking and responding FEs.

Table 3 FE Combinations for AUTHDIRFWD

	INVOKING FE	RESPONDING FE
Case 1	Anchor MSC	Serving MSC
Case 2	Anchor MSC	Tandem MSC
Case 3	Tandem MSC	Serving MSC

4.2.1 Successful AuthenticationDirectiveForward

This scenario describes the successful use of the AuthenticationDirectiveForward operation.

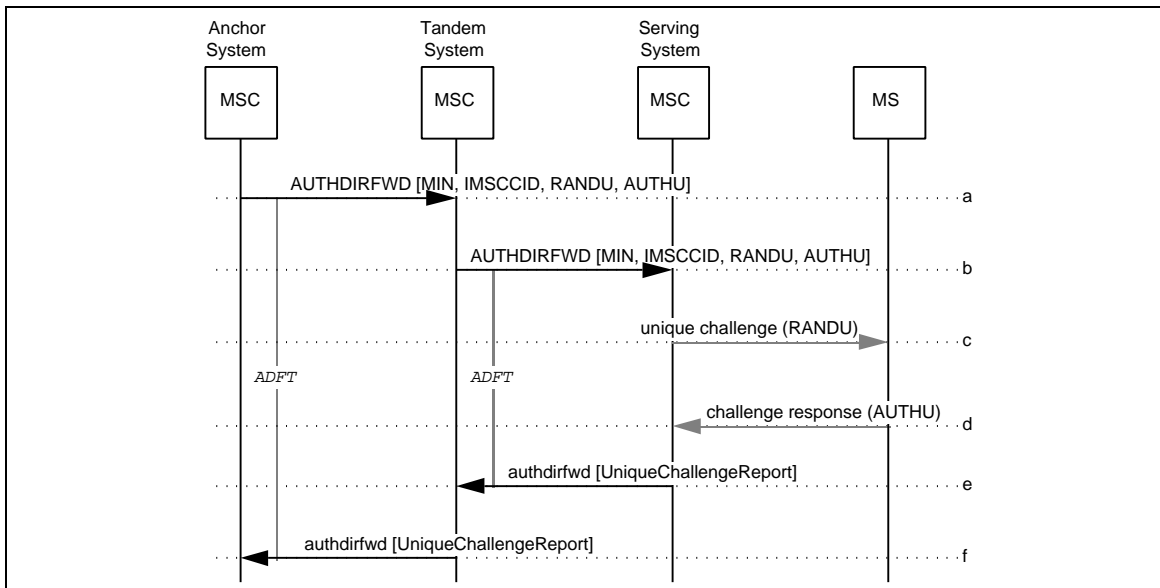

Figure 7 Successful AuthenticationDirectiveForward

- 1
2
3
4
5
6
- a. Following an intersystem handoff, the Anchor MSC receives a request to perform a Unique Challenge for the indicated MS. The MSC sends an AUTHDIRFWD to the Tandem MSC.

Parameters	Usage	Type
MIN	MS MIN.	R
IMSCCID	Specifies the trunk in a dedicated trunk group between the two MSCs for the call involved.	R
RANDU	Random number used by the Serving MSC for the Unique Challenge	R
AUTHU	The expected response from the MS to the Unique Challenge	R

- 7
8
9
10
11
12
13
14
15
16
17
18
19
20
21
22
23
24
25
26
27
- b. The Tandem MSC adjusts the InterMSCCircuitID to identify the circuit between it and the Serving MSC, and forwards the AUTHDI RFWD to the Serving MSC. Parameters are as in Step-a.
- c. The Serving MSC sends a Unique Challenge Order to the MS using the RANDU value received.
- d. The Serving MSC receives the MS response to the Unique Challenge.
- e. The Serving MSC reports the outcome of the Unique Challenge by initiating an authdi rfw to the Tandem MSC.

Parameters	Usage	Type
UniqueChallengeReport	Reports the outcome of the Unique Challenge	R

- 28
29
30
31
32
33
34
35
36
37
38
39
40
41
42
43
44
45
46
47
48
49
50
51
52
53
54
55
56
57
58
59
60
- f. The Tandem MSC forwards the authdi rfw to the Anchor MSC.

4.3 AuthenticationFailureReport

The AuthenticationFailureReport (AFREPORT) operation is used to report on an authentication failure for a mobile station.

The following table lists the valid combinations of invoking and responding FEs.

Table 4 FE Combinations for AFREPORT

	INVOKING FE	RESPONDING FE
Case 1	Serving MSC	Serving VLR
Case 2	Serving VLR	HLR
Case 3	HLR	AC

4.3.1 Successful AuthenticationFailureReport: Access Denied on Initial Registration

This scenario describes the successful use of the AuthenticationFailureReport operation to report a RANDC mismatch upon initial registration. The MS is aware that authentication is required for all system accesses. The result of the operation is to deny access.

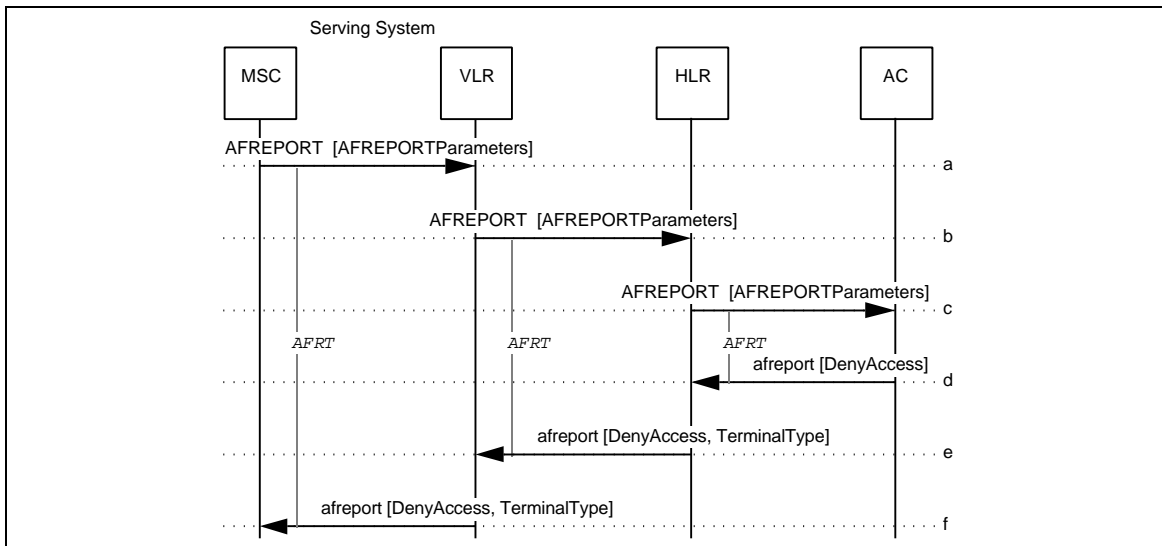

Figure 8 Access Denied on Initial Registration

1
2
3
4
5
6
7
8
9
10
11
12
13
14
15
16
17
18
19
20
21
22
23
24
25
26
27
28
29
30
31
32
33
34
35
36
37
38
39
40
41
42
43
44
45
46
47
48
49
50
51
52
53
54
55
56
57
58
59
60

- a. The Serving MSC determines that an Authentication Failure Report is necessary due to a RANDC mismatch and sends an AFREPORT to the Serving VLR.

Parameters	Usage	Type
AFREPORTParameters:	Set of parameters in AFREPORT:	
[MIN]	Served MS MIN.	R
[ESN]	Served MS ESN.	R
[MSCID]	Serving MSC MSCID.	R
[ReportType]	The type of authentication failure reported = <i>RANDC mismatch</i> .	R
[SystemAccessType]	Type of MS system access = registration.	R
[SystemCapabilities]	Authentication capabilities of Serving MSC.	R

- b. The VLR sends an AFREPORT to the HLR associated with the MS.

Parameters are as in Step-a, with the following modifications:		
Parameters	Usage	Type
[SystemCapabilities]	Authentication capabilities of Serving VLR.	R

- c. The HLR forwards the AFREPORT to the AC. Parameters are as in Step-b.
- d. The AC determines that the MS should be denied access. The AC returns an **afreport** to the requesting HLR and includes the DenyAccess parameter.

Parameters	Usage	Type
DenyAccess	Indication that MS should be denied access with reason; release of system resources allocated for this access may be initiated by the MSC. This may include disconnection of any call in progress.	O

- e. The HLR forwards the **afreport** to the Serving VLR.

Parameters are as in Step-d, with the following additions:		
Parameters	Usage	Type
TerminalType	Include on IS-41-C or later.	O

- f. The Serving VLR forwards the **afreport** to the Serving MSC. Parameters are as in Step-e.

4.4 AuthenticationRequest

The AuthenticationRequest (AUTHREQ) operation is used to request authentication of an authentication-capable MS.

The following table lists the valid combinations of invoking and responding FEs.

Table 5 FE Combinations for AUTHREQ

	INVOKING FE	RESPONDING FE
Case 1	Serving MSC	Serving VLR
Case 2	Serving VLR	HLR
Case 3	HLR	AC

Authentication may be initiated under the following circumstances:

1. When the MS is informed that authentication is required on system accesses and:
 - a. the MS attempts initial registration,
 - b. the MS attempts call origination,
 - c. the MS attempts call termination, or
 - d. the MS issues an in-call flash request.
2. When the MS is informed that authentication is not required on system accesses and the MS attempts an initial system access (e.g., registration, origination, page response).

Also, the AuthenticationRequest operation may vary depending on whether SSD is shared or not.

4.4.1 Successful Authentication on Initial Access

This operation scenario describes the successful use of the AuthenticationRequest operation to authenticate an MS which is attempting initial access. The MS is aware that authentication is required on all system accesses. The result of the operation is to allow access.

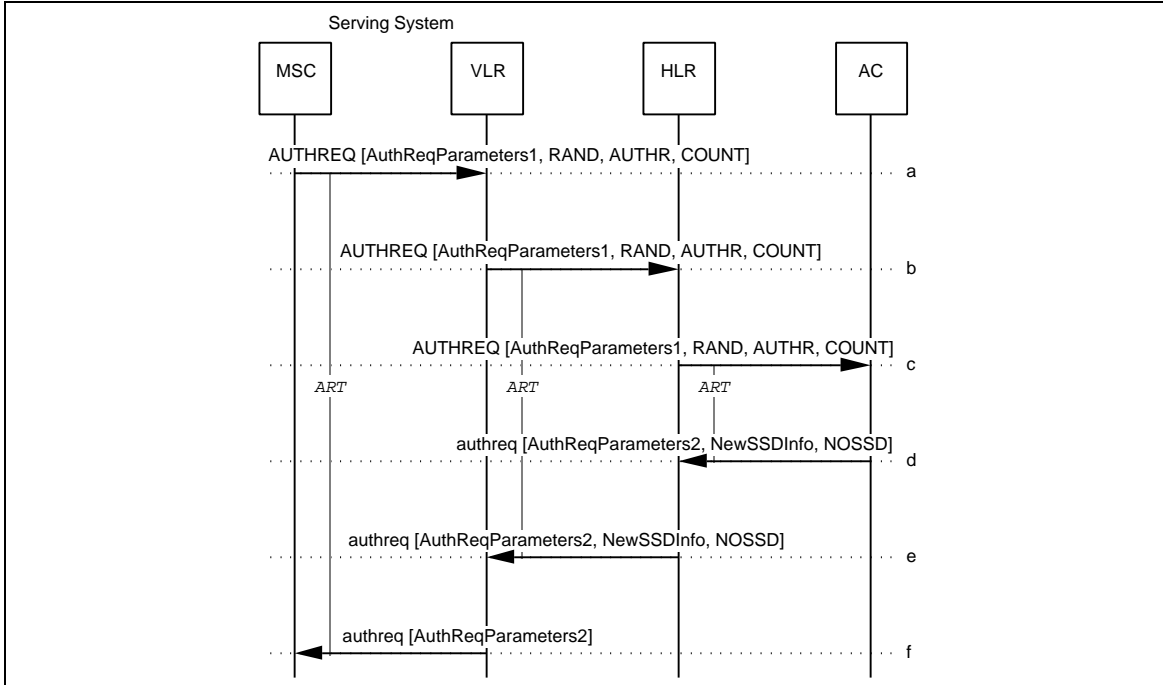

Figure 9 Successful Authentication on Initial Access

- 1
2
3 a. On an initial access attempt by an authentication-capable MS, the Serving MSC sends
4 an AUTHREQ to the Serving VLR.

Parameters	Usage	Type
AuthReqParameters1:	Set of parameters in AUTHREQ:	
[MIN]	Served MS MIN.	R
[ESN]	Served MS ESN.	R
[MSCID]	Serving MSC MSCID.	R
[PC_SSN]	Serving MSC PC_SSN. Include if SS7 carriage services are used.	O
[SystemCapabilities]	Authentication capabilities of Serving MSC.	R
[SystemAccessType]	Type of system access = registration.	R
[TerminalType]	Identifies the radio frequency interface standard supported by the associated MS	R
RAND	Random number derived from MS-provided RANDC by Serving MSC.	R
AUTHR	Authentication result provided by MS.	R
COUNT	Value of CallHistoryCount provided by MS.	R

- 21
22
23 b. The VLR sends an AUTHREQ to the HLR associated with the MS.
24
25
26

Parameters are as in Step-a, with the following modifications:		
Parameters	Usage	Type
[SystemCapabilities]	Authentication capabilities of Serving VLR.	R
[PC_SSN]	Serving VLR PC_SSN. Include if SS7 carriage services are used.	O

- 27
28
29
30
31
32
33
34
35 c. The HLR forwards the AUTHREQ to the AC. Parameters are as in Step -b.
36
37
38
39
40
41
42
43
44
45
46
47
48
49
50
51
52
53
54
55
56
57
58
59
60

- d. The AC determines that the MS should be allowed access. The AC sends an **authreq** to the HLR.

Parameters	Usage	Type
AuthReqParameters2:	Set of parameters in authreq:	
[CallHistoryCount]	Event counter used for clone detection. Included if SSD is shared.	O
[RANDSSD]	Random number for SSD generation. Included if a SSD update and a Unique Challenge to the MS should be initiated by the serving system.	O
[RANDU]	Random number generated by AC to produce AUTHU. Included if a Unique Challenge to the MS should be initiated by the serving system.	O
[AUTHU]	Expected MS response to Unique Challenge Order as calculated by AC. Included if a Unique Challenge to the MS should be initiated by the serving system.	O
[UpdateCount]	Indicates that the COUNT update procedure should be initiated by the serving system.	O
NewSSDInfo:	New SSD information:	
[Authentication-AlgorithmVersion]	Include if SSD included to select authentication algorithm other than default.	O
[SSD]	New value of VLR and AC shared secret data. May be included if the SystemCapabilities of the VLR include "CAVE execution" and AC administration policies allow distribution of the SSD.	O
NOSSD	Indicates that previously provided SSD is no longer valid and should be discarded.	O

- e. The HLR forwards the **authreq** to the Serving VLR. Parameters are as in Step-d.
- f. The Serving VLR forwards the **authreq** to the Serving MSC. Parameters are as in Step-d, with the exception that the SSD, AAV and NOSSD parameters are not included.

4.4.2 Failed Authentication on Initial Access

This operation scenario describes the successful use of the AuthenticationRequest operation to authenticate an MS failing authentication upon initial access. The MS is aware that authentication is required on all system accesses. The result of the operation is to deny access.

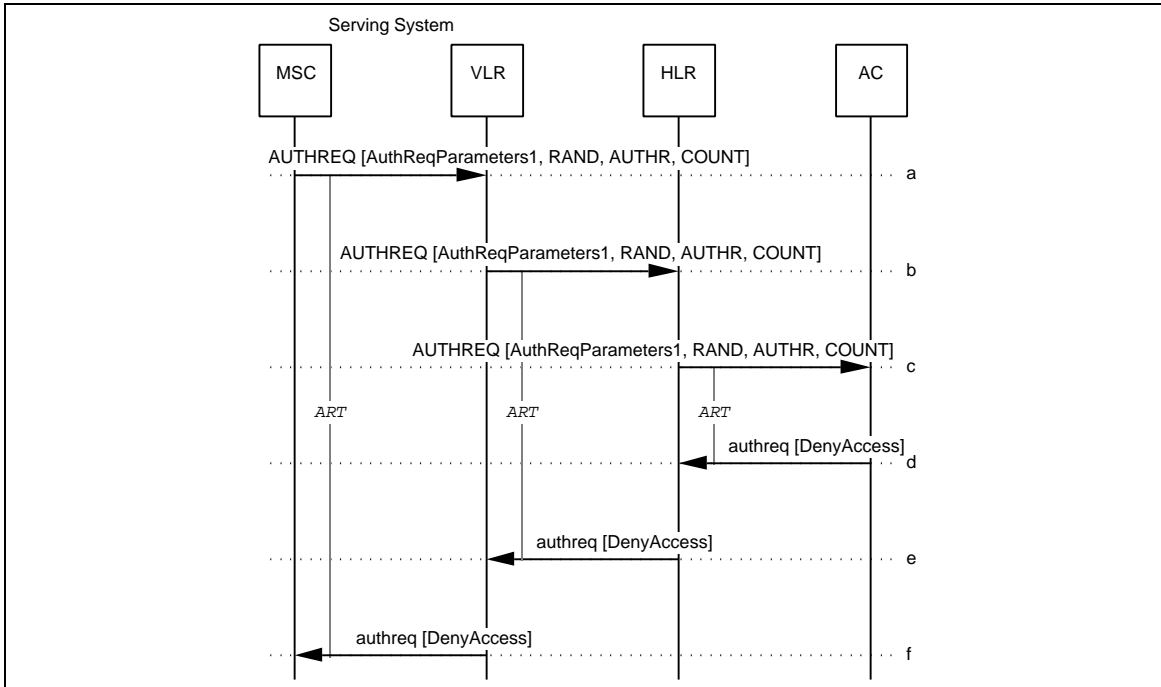

Figure 10 Failed Authentication on Initial Access

- a-c. Same as Section 4.4.1, Steps a-c.
- d. The AC determines that the MS should be denied access. The AC sends an **authreq** to the HLR including an indication to this effect, with reason for denial.

Parameters	Usage	Type
DenyAccess	Indication that MS is invalid.	R

- e. The HLR forwards the **authreq** to the Serving VLR. Parameters are as in Step-d.
- f. The Serving VLR forwards the **authreq** to the Serving MSC. Parameters are as in Step-d.

4.4.3 Successful Authentication on Call Origination (SSD not shared)

This operation scenario describes the use of the AuthenticationRequest operation to authenticate an MS which is attempting call origination on a serving system that is not sharing SSD with the AC. The MS is aware that authentication is required on all system accesses. The result of the operation is to allow origination.

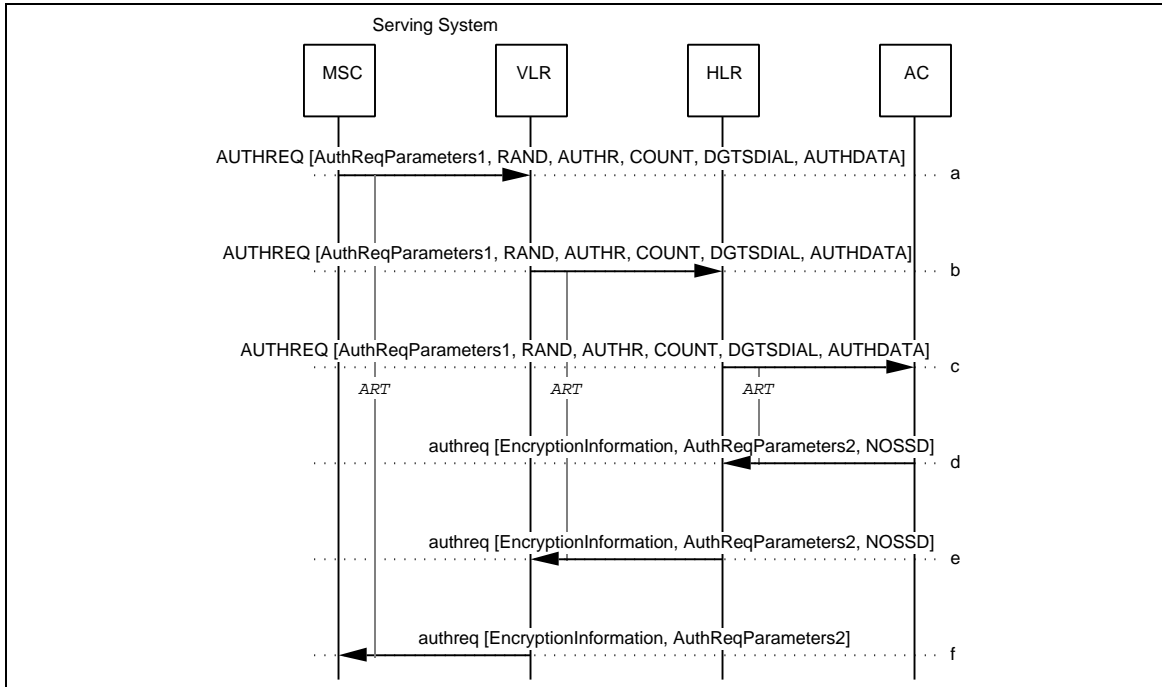

Figure 11 Successful Authentication on Call Origination (SSD not shared)

- 1
2
3
4
5
6
7
8
9
10
11
12
13
14
15
16
17
18
19
20
21
22
23
24
25
26
27
28
29
30
31
32
33
34
35
36
37
38
39
40
41
42
43
44
45
46
47
48
49
50
51
52
53
54
55
56
57
58
59
60
- a. On a call origination attempt by an MS, the Serving MSC sends an AUTHREQ to the Serving VLR.

Parameters are as in Section 4.4.1, Step-a, with the following addition and modifications:		
Parameters	Usage	Type
AuthReqParameters1: [SystemAccessType]	Set of parameters in AUTHREQ: Type of system access = call origination.	R
DGTSDIAL	Digits, entered by served MS, which identify the called party.	R
AUTHDATA	The authentication data used by the MS to compute AUTHR for call origination.	O

- b. The VLR sends an AUTHREQ to the HLR associated with the MS.

Parameters are as in Step-a, with the following modifications:		
Parameters	Usage	Type
[SystemCapabilities]	Authentication capabilities of Serving VLR.	R
[PC_SSN]	Serving VLR PC_SSN. Include if SS7 carriage services are used.	O

- c. The HLR forwards the AUTHREQ to the AC. Parameters are as in Step-b.

- d. The AC determines that the MS is valid. The AC sends an authreq to the HLR.

Parameters are as in Section 4.4.1, Step-d, with the exception that the SSD and AAV parameters are not included and with the following additions:		
Parameters	Usage	Type
NOSSD	SSD not shared.	O
EncryptionInformation: [CDMAPLCM]	CDMAPrivateLongCodeMask. Include if generated by AC.	O
[SMEKEY]	SignalingMessageEncryptionKey. Include if generated by AC.	O
[VPMASK]	VoicePrivacyMask. Include if generated by AC.	O

- e. The HLR forwards the **authreq** to the Serving VLR.

Parameters are as in Section 4.4.1, Step-d, with the exception that the SSD and AAV parameters are not included and with the following additions:		
Parameters	Usage	Type
NOSSD	SSD not shared.	O
EncryptionInformation		
[CDMAPLCM]	CDMAPrivateLongCodeMask. Include if available and MS is subscribed to Voice Privacy.	O
[SMEKEY]	SignalingMessageEncryptionKey. Include if available.	O
[VPMASK]	VoicePrivacyMask. Include if available and MS is subscribed to Voice Privacy.	O

- f. The Serving VLR forwards the **authreq** to the Serving MSC. Parameters are as in Step-d, with the exception that the NOSSD parameter is not included.

1
2
3
4
5
6
7
8
9
10
11
12
13
14
15
16
17
18
19
20
21
22
23
24
25
26
27
28
29
30
31
32
33
34
35
36
37
38
39
40
41
42
43
44
45
46
47
48
49
50
51
52
53
54
55
56
57
58
59
60

4.4.4 Successful Authentication on Call Termination (SSD not shared)

This operation scenario describes the use of the AuthenticationRequest operation to authenticate an MS which is attempting call termination on a serving system that is not sharing SSD with the AC. The MS is aware that authentication is required on all system accesses. The result of the operation is to allow termination.

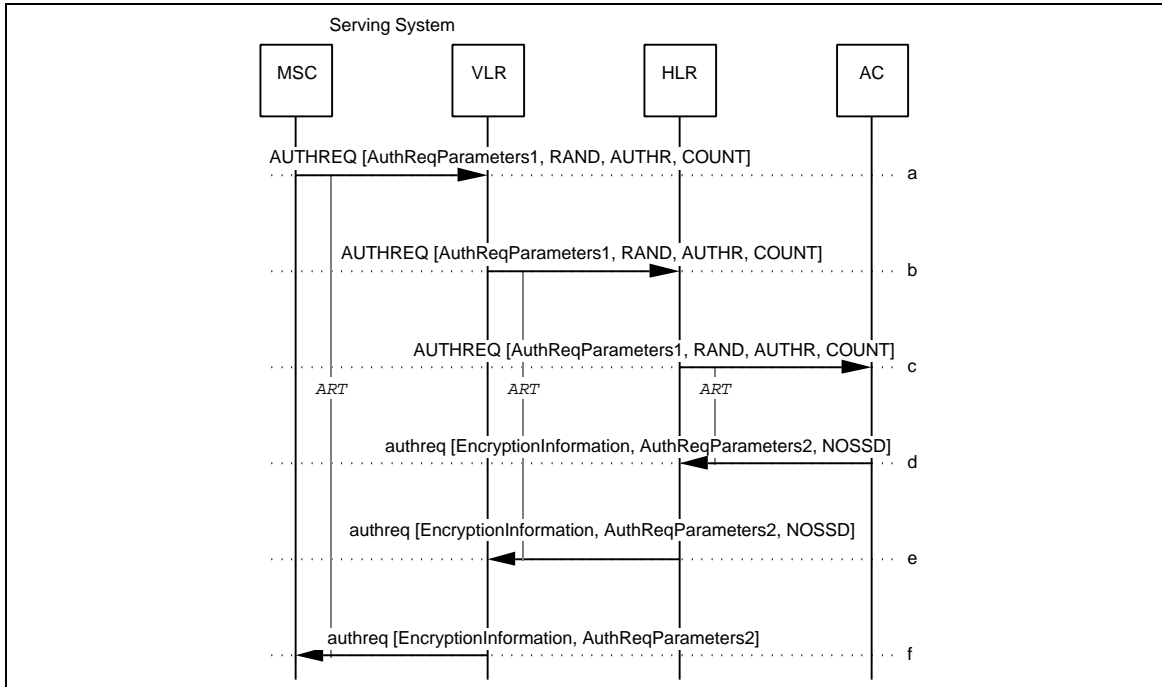

Figure 12 Successful Authentication on Call Termination (SSD not shared)

- a. On a call termination attempt to an MS, the Serving MSC sends an AUTHREQ to the Serving VLR.

Parameters are as in Section 4.4.1, Step-a, with the following modifications:		
Parameters	Usage	Type
AuthReqParameters1: [SystemAccessType]	Set of parameters in AUTHREQ: Type of system access = page response.	R

- b-c. Same as Section 4.4.1, Steps b-c.
- d. The AC determines that the MS is valid. The AC sends an authreq to the HLR. The message may contain the parameters in Section 4.4.3, Step-d.
- e. The HLR forwards the authreq to the Serving VLR. Parameters are as in Step-d.
- f. The Serving VLR forwards the authreq to the Serving MSC. Parameters are as in Step-d, with the exception that the NOSSD parameter is not included.

4.4.5 Initiate Authentication on Voice Channel (SSD not shared)

This operation scenario describes the use of the AuthenticationRequest operation to initiate authentication of an MS which is attempting system access on a serving system that is not sharing SSD with the AC.

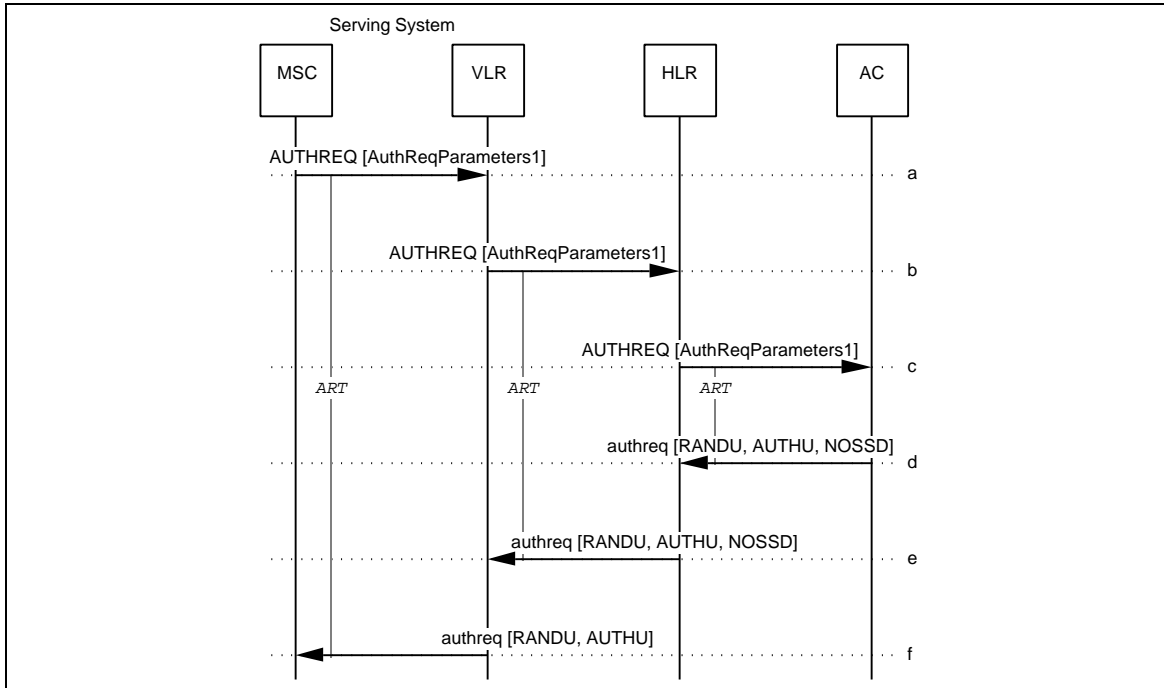

Figure 13 Initiate Authentication on Voice Channel (SSD not shared)

- 1
2
3
4
5
6
7
8
9
10
11
12
13
14
15
16
17
18
19
20
21
22
- a. On a system access attempt (i.e., registration, origination, page response, or flash request) by an MS, the Serving MSC sends an AUTHREQ to the Serving VLR.

Parameters	Usage	Type
AuthReqParameters1:	Set of parameters in AUTHREQ:	
[MIN]	Served MS MIN.	R
[ESN]	Served MS ESN.	R
[MSCID]	Serving MSC MSCID.	R
[PC_SSN]	Serving MSC PC_SSN. Include if SS7 carriage services are used.	O
[SystemCapabilities]	Authentication capabilities of Serving MSC.	R
[SystemAccessType]	Type of system access.	R
[TerminalType]	Identifies the radio frequency interface standard supported by the associated MS	R

- b. The VLR sends an AUTHREQ to the HLR associated with the MS.

Parameters are as in Step-a, with the following modifications:		
Parameters	Usage	Type
[SystemCapabilities]	Authentication capabilities of Serving VLR.	R
[PC_SSN]	Serving VLR PC_SSN. Include if SS7 carriage services are used.	O

- c. The HLR forwards the AUTHREQ to the AC. Parameters are as in Step-b.
- d. The AC sends an authreq to the HLR, including the RANDU and expected AUTHU result.

Parameters	Usage	Type
RANDU	Random number generated by AC to produce AUTHU.	R
AUTHU	Expected MS response to Unique Challenge Order as calculated by AC.	R
NOSSD	Indicates that previously provided SSD is no longer valid and should be discarded.	O

- e. The HLR forwards the authreq to the Serving VLR. Parameters are as in Step-d.
- f. The Serving VLR forwards the authreq to the Serving MSC, the receipt of which indicates that a Unique Challenge order should be sent to the MS. Parameters are as in Step-d, with the exception that the NOSSD parameter is not included.
- 23
24
25
26
27
28
29
30
31
32
33
34
35
36
37
38
39
40
41
42
43
44
45
46
47
48
49
50
51
52
53
54
55
56
57
58
59
60

4.4.6 Successful Authentication on Call Origination (SSD shared)

This operation scenario describes the use of the AuthenticationRequest operation to authenticate an MS which is attempting call origination on a serving system that is sharing SSD with the AC. The MS is aware that authentication is required on all system accesses. The result of the operation is to allow origination.

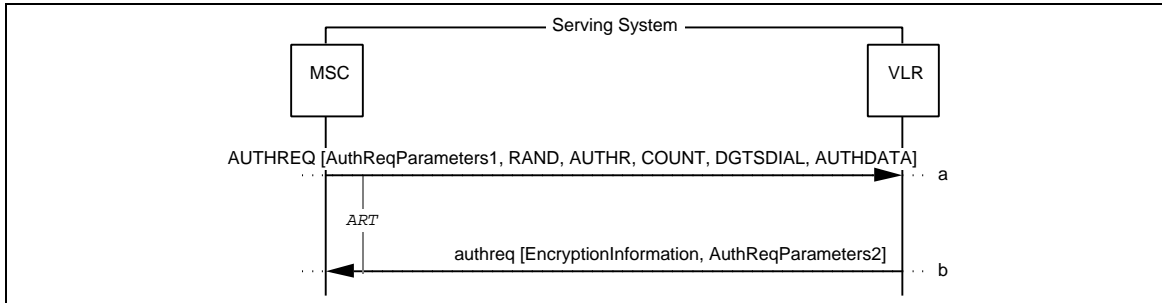

Figure 14 Successful Authentication on Call Origination (SSD shared)

- a. On a call origination attempt by an MS, the Serving MSC sends an AUTHREQ to the Serving VLR. Parameters are as in Section 4.4.3, Step-a.
- b. The Serving VLR determines that the MS is valid. The VLR sends an authreq to the Serving MSC.

Parameters	Usage	Type
AuthReqParameters2:	Set of parameters in authreq:	
[CallHistoryCount]	Event counter used for clone detection. Included if SSD is shared.	O
[RANDU]	Random number generated by VLR to produce AUTHU. Included if a Unique Challenge to the MS should be initiated by the serving system.	O
[AUTHU]	Expected MS response to Unique Challenge Order as calculated by VLR. Included if a Unique Challenge to the MS should be initiated by the serving system.	O
[UpdateCount]	Indicates that the COUNT update procedure should be initiated by the serving system.	O
EncryptionInformation		
[CDMAPLCM]	CDMAPrivateLongCodeMask. Include if available and MS is subscribed to Voice Privacy.	O
[SMEKEY]	SignalingMessageEncryptionKey. Include if available.	O
[VPMASK]	VoicePrivacyMask. Include if available and MS is subscribed to Voice Privacy.	O

4.4.7 Successful Authentication on Call Termination (SSD shared)

This operation scenario describes the use of the AuthenticationRequest operation to authenticate an MS which is attempting call termination on a serving system that is sharing SSD with the AC. The MS is aware that authentication is required on all system accesses. The result of the operation is to allow termination.

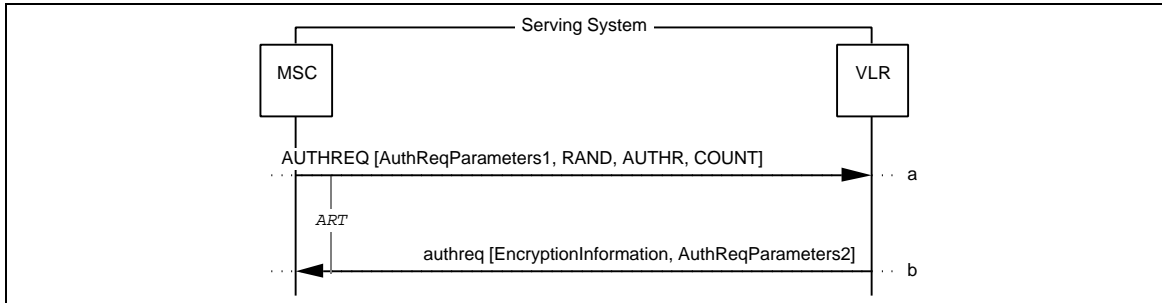
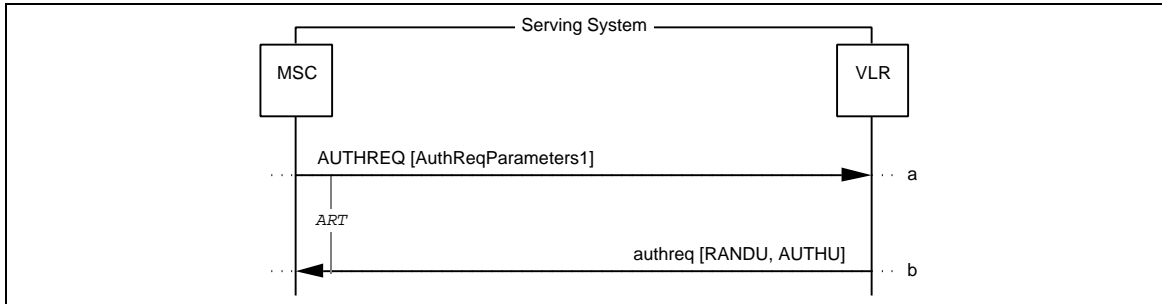

Figure 15 Successful Authentication on Call Termination (SSD shared)

- a. Same as Section 4.4.1, Step-a.
- b. Same as Section 4.4.6, Step-b.

1
2
3
4 **4.4.8 Initiate Authentication on Voice Channel (SSD shared)**

5
6 This operation scenario describes the use of the AuthenticationRequest operation to initiate
7 authentication of an MS which is attempting system access on a serving system that is
8 sharing SSD with the AC. Authentication is on the voice channel.
9



10
11
12
13
14
15
16
17
18
19
20 **Figure 16 Initiate authentication on voice channel (SSD shared)**

- 21
22
23 a. Same as Section 4.4.5, Step-a.
24
25 b. The Serving VLR sends an **authreq** to the Serving MSC, including the RANDU and
26 expected AUTHU result. This indicates that a Unique Challenge order should be
27 sent to the MS.
28

29

Parameters	Usage	Type
RANDU	Random number generated by VLR to produce AUTHU.	R
AUTHU	Expected MS response to Unique Challenge Order as calculated by VLR.	R

30
31
32
33
34
35
36
37
38
39
40
41
42
43
44
45
46
47
48
49
50
51
52
53
54
55
56
57
58
59
60

4.5 AuthenticationStatusReport

The AuthenticationStatusReport (ASREPORT) operation is used to report a security event associated with an MS.

The following table lists the valid combinations of invoking and responding FEs.

Table 6 FE Combinations for ASREPORT

	INVOKING FE	RESPONDING FE
Case 1	Serving MSC	Serving VLR
Case 2	Serving VLR	HLR
Case 3	HLR	AC

4.5.1 Report of AC-initiated Action

This operation scenario describes the use of the AuthenticationStatusReport operation to report the results of an AC-initiated action.

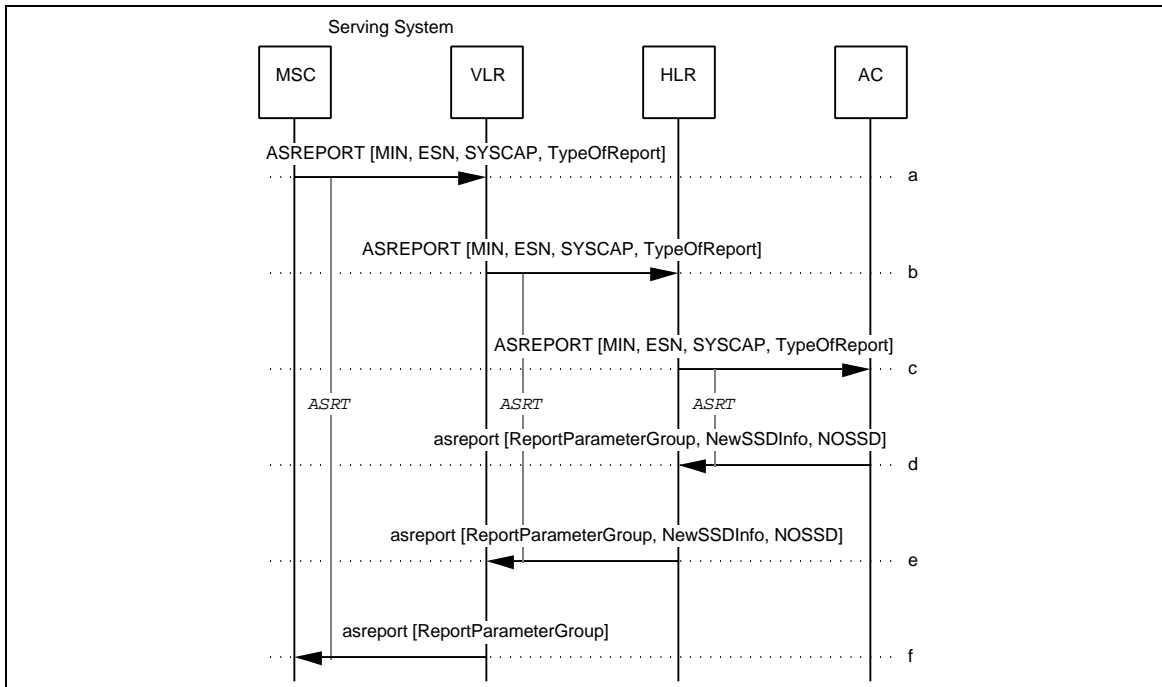

Figure 17 Report of AC-initiated action

- 1
2
3 a. If the Serving MSC determines that an Authentication Status Report is necessary, it
4 sends an ASREPORT to the Serving VLR.

Parameters	Usage	Type
MIN	Served MS MIN.	R
ESN	Served MS ESN.	R
SYSCAP	Authentication capabilities of Serving MSC.	R
TypeOfReport:	The type of report provided:	
[SSDUpdateReport]	Indicates the output of the SSD Update. Include if previously requested.	O
[UniqueChallengeReport]	Indicates the output of the Unique Challenge. Include if previously requested.	O
[CountUpdateReport]	Indicates the output of the COUNT Update. Include if previously requested.	O

- 5
6
7
8
9
10
11
12
13
14
15
16
17
18
19
20
21 b. The Serving VLR, noting that the report is not for an operation it has initiated, updates
22 the SYSCAP parameter to reflect the authentication capabilities of the serving system,
23 both MSC and VLR, and forwards the ASREPORT to the HLR associated with the
24 MS.
25
26 c. The HLR forwards the ASREPORT to the AC. Parameters are as in Step -a.
27
28
29
30
31
32
33
34
35
36
37
38
39
40
41
42
43
44
45
46
47
48
49
50
51
52
53
54
55
56
57
58
59
60

- d. The AC returns an **asreport**, with appropriate parameters, to the requesting HLR.

Parameters	Usage	Type
ReportParameterGroup:	Set of report parameters in asreport:	
[DenyAccess]	Indication that MS should be denied access with reason; release of system resources allocated for this access may be initiated by the MSC. This may include disconnection of any call in progress.	O
[CallHistoryCount]	New value of event counter used for clone detection.	O
[RANDSSD]	Random number for SSD generation. Included if a SSD update and a Unique Challenge to the MS should be initiated by the serving system.	O
[RANDU]	Random number generated by AC to produce AUTHU. Included if a Unique Challenge to the MS should be initiated by the serving system.	O
[AUTHU]	Expected MS response to Unique Challenge Order as calculated by AC. Included if a Unique Challenge to the MS should be initiated by the serving system.	O
[UpdateCount]	Indicates that the COUNT update procedure should be initiated by the serving system.	O
NewSSDInfo:	New SSD information:	
[Authentication-AlgorithmVersion]	Include to select authentication algorithm other than default.	O
[SSD]	New value of MS and AC shared secret data. May be included if the SystemCapabilities include 'CAVE execution' and AC administration policies allow distribution of the SSD.	O
NOSSD	Indicates that previously provided SSD is no longer valid and should be discarded.	O

- e. The HLR forwards the **asreport** to the Serving VLR. Parameters are as in Step-d.
- f. The Serving VLR forwards the **asreport** to the Serving MSC. Parameters are as in Step-d, with the exception that the SSD, AAV, and NOSSD parameters are not included.

4.5.2 Report of VLR-initiated Action

This operation scenario describes the normal use of the AuthenticationStatusReport operation to report the results of a VLR-initiated action.

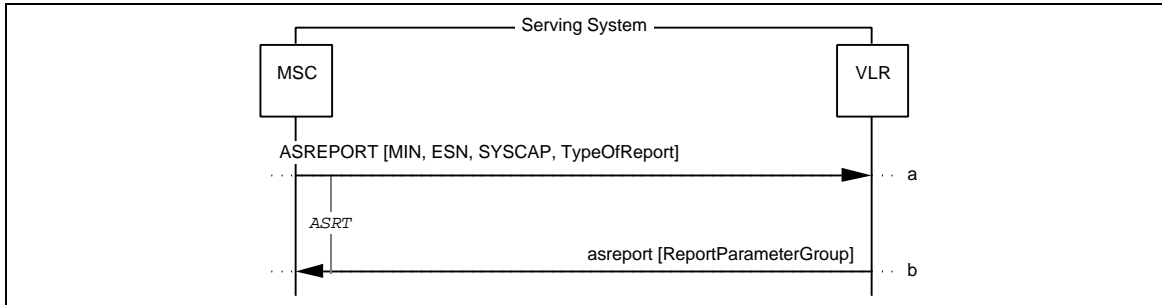

Figure 18 Report of VLR-initiated action

- a. If the Serving MSC determines that an Authentication Status Report is necessary, it sends an ASREPORT to the Serving VLR.

Parameters	Usage	Type
MIN	Served MS MIN.	R
ESN	Served MS ESN.	R
SYSCAP	Authentication capabilities of Serving MSC.	R
TypeOfReport:	The type of report provided:	
[UniqueChallengeReport]	Indicates the output of the Unique Challenge. Include if previously requested.	O
[CountUpdateReport]	Indicates the output of the COUNT Update. Include if previously requested.	O

- b. If the ASREPORT indicates completion of an operation initiated by the Serving VLR, then the Serving VLR sends an asreport, with appropriate parameters, to the Serving MSC.

Parameters are as in Section 4.5.1, Step-f, with the exception with the following modifications:		
Parameters	Usage	Type
[RANDU]	Random number generated by VLR to produce AUTHU. Included if a Unique Challenge to the MS should be initiated by the serving system.	O
[AUTHU]	Expected MS response to Unique Challenge Order as calculated by VLR. Included if a Unique Challenge to the MS should be initiated by the serving system.	O

4.6 BaseStationChallenge

The BaseStationChallenge (BSCHALL) operation is used to request a response to a Base Station Challenge Order received from an MS.

The following table lists the valid combinations of invoking and responding FEs.

Table 7FE Combinations for BSCHALL

	INVOKING FE	RESPONDING FE
Case 1	Serving MSC	Serving VLR
Case 2	Serving VLR	HLR
Case 3	HLR	AC

4.6.1 Base Station Challenge with SSD not shared

This operation scenario describes the normal use of the BaseStationChallenge operation when SSD is not shared between the serving system and the AC.

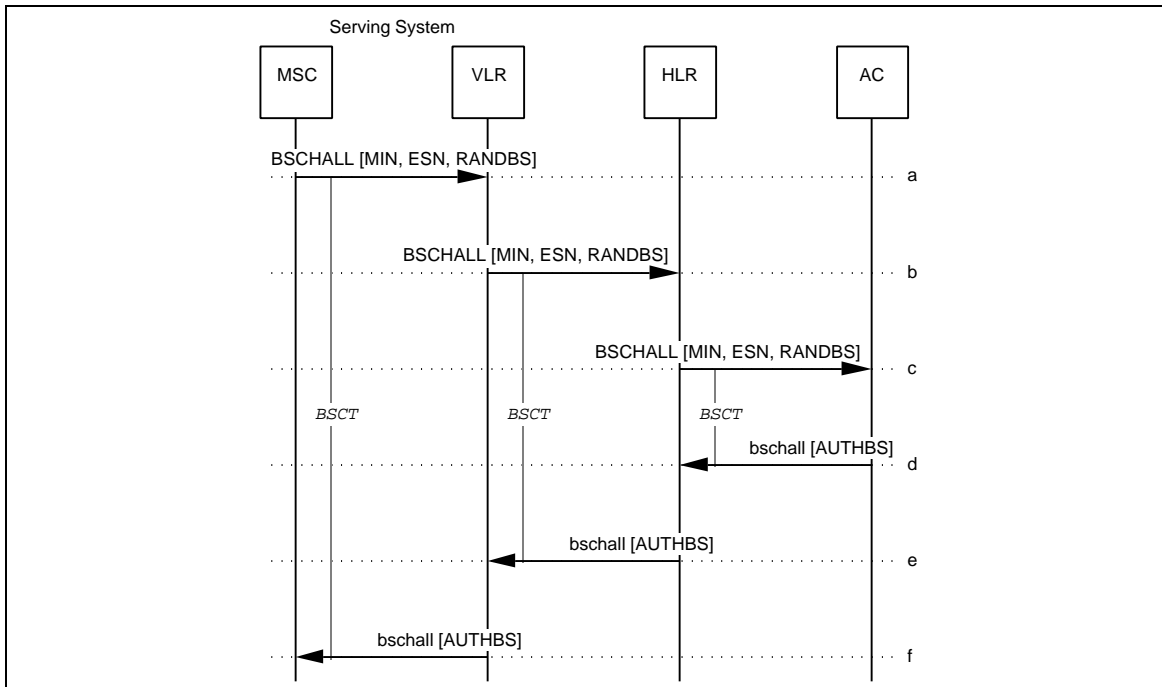

Figure 19 Base Station Challenge with SSD not shared

- 1
2
3 a. On a Base Station Challenge Order received from an MS, the Serving MSC sends a
4 BSCHALL to the Serving VLR.

Parameters	Usage	Type
MIN	Served MS MIN.	R
ESN	Served MS ESN.	R
RANDBS	Random number provided by MS for Base Station Challenge.	R

- 5
6
7
8
9
10
11
12
13 b. Since SSD is not shared with the VLR, the VLR forwards the BSCHALL to the HLR
14 associated with the MS. Parameters are as in Step-a.
15
16 c. The HLR forwards the BSCHALL to the AC. Parameters are as in Step-a.
17
18 d. The AC executes CAVE using the pending SSD¹ of the MS and RANDBS and sends
19 a bschal I to the HLR, including the AUTHBS result.

Parameters	Usage	Type
AUTHBS	Base Station Challenge Authentication Result as calculated by AC.	R

- 20
21
22
23
24 e. The HLR forwards the bschal I to the Serving VLR. Parameters are as in Step-d.
25
26 f. The Serving VLR forwards the bschal I to the Serving MSC, which uses this
27 information to respond to the MS. Parameters are as in Step -d.
28
29
30
31
32
33
34
35
36
37
38
39
40
41
42
43
44
45
46
47
48
49
50
51
52

53
54
55 ¹ See IS 41.6 Annex B for explanation of pending SSD.
56
57
58
59
60

4.6.2 Base Station Challenge with SSD shared

This operation scenario describes the normal use of the BaseStationChallenge operation when SSD is shared between the serving system and the AC.

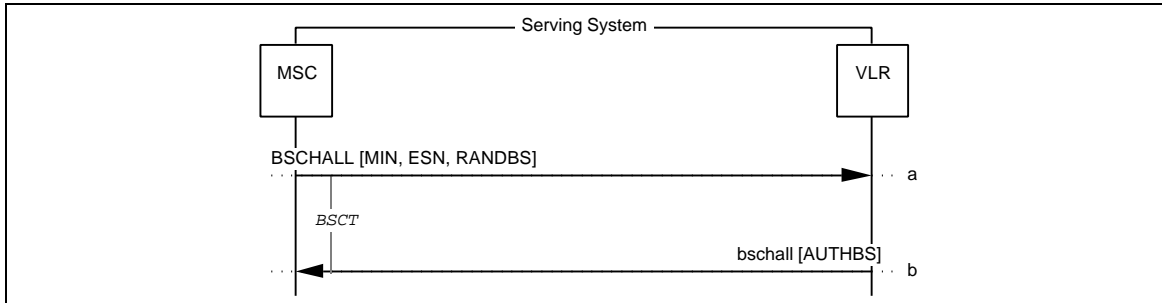

Figure 20 Base Station Challenge with SSD shared

- a. Same as Section 4.6.1, Step-a.
- b. The Serving VLR executes CAVE using the pending SSD² of the MS and RANDBS and sends a **bschal I** to the Serving MSC, including the AUTHBS result. The Serving MSC uses this information to respond to the MS.

Parameters	Usage	Type
AUTHBS	Base Station Challenge Authentication Result as calculated by VLR.	R

4.7 BulkDeregistration

The BulkDeregistration (BULKDEREG) operation is used by a VLR to inform the HLR that all roaming MS data associated with the VLR has been removed.

²See IS 41.6 Annex B for explanation of pending SSD.

The following table lists the valid combinations of invoking and responding FEs.

Table 8 FE Combination for BULKDEREG

	INVOKING FE	RESPONDING FE
Case 1	Serving VLR	HLR

4.7.1 Successful BulkDeregistration

This scenario describes the normal use of the BulkDeregistration operation.

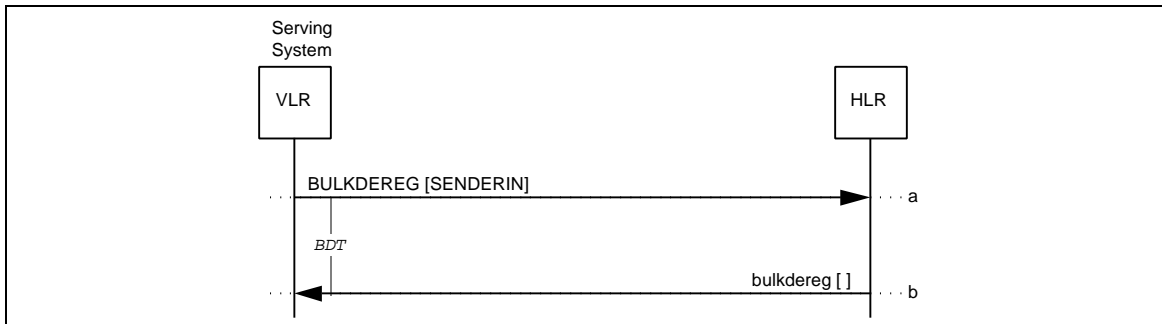

Figure 21 Successful BulkDeregistration

- a. The VLR sends a BULKDEREG to the HLR to inform the HLR that the VLR has removed all roaming MS data associated with the HLR.

Parameters	Usage	Type
SENDERIN	The VLR's Sender Identification Number to identify discarded MS records.	R

- b. The HLR acknowledges receipt of the BULKDEREG via an empty bul kdereg.

4.8 CountRequest

The CountRequest (COUNTREQ) operation is used to obtain the current value of the CallHistoryCount parameter (COUNT).

The following table lists the valid combinations of invoking and responding FEs.

Table 9 FE Combinations for COUNTREQ

	INVOKING FE	RESPONDING FE
Case 1	AC	HLR
Case 2	HLR	Old Serving VLR

4.8.1 Successful CountRequest

This operation scenario describes the normal use of the CountRequest operation.

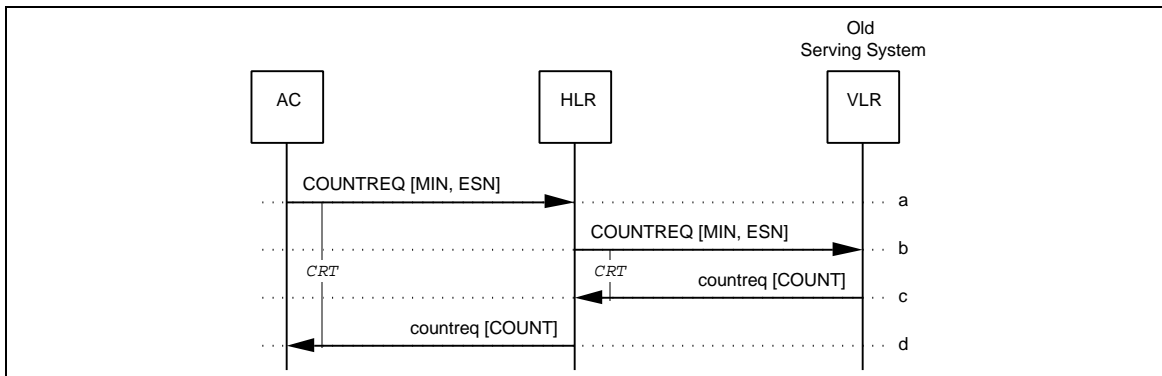

Figure 22 Successful CountRequest

- a. If an AC determines that it needs to retrieve the current value of an MS's COUNT from the old serving system, it sends a COUNTREQ to the MS's associated HLR.

Parameters	Usage	Type
MIN	Served MS MIN.	R
ESN	Served MS ESN.	R

- b. The HLR forwards the COUNTREQ to the Old Serving VLR. Parameters are as in Step-a.
- c. On receipt of the message, the Old Serving VLR includes the current value of COUNT in a countreq and sends it to the HLR.

Parameters	Usage	Type
COUNT	Event counter used for clone detection.	R

- d. The HLR forwards the countreq to the AC. Parameters are as in Step-c.

4.9 FeatureRequest

The FeatureRequest (FEATREQ) operation is used to request feature-related treatment on behalf of a registered MS. The following table lists the valid combinations of invoking and responding FEs.

Table 10 FE Combinations for FEATREQ

	INVOKING FE	RESPONDING FE
Case 1	Serving MSC	HLR
Case 2 (Note)	<i>Serving MSC</i>	<i>Serving VLR</i>
Case 3 (Note)	<i>Serving VLR</i>	<i>HLR</i>

Case 1 above is termed a 'direct' FeatureRequest operation, since it occurs directly between the Serving MSC and the HLR without the involvement of the VLR.

One of several possible results is returned:

1. Notification that the feature request was successful with an (optional) indication of the treatment to provide the served MS.
2. Notification that the feature request was unsuccessful with an (optional) indication of the treatment to provide the served MS.

Possible served MS treatment includes provision of a tone or announcement, call release, or further call routing based on the specifics of the feature request.

Note: These cases are no longer recommended.

4.9.1 Direct FeatureRequest without Call Routing

This operation scenario describes a direct FeatureRequest operation when the response from the HLR does not include instructions for the serving system to set up the call.

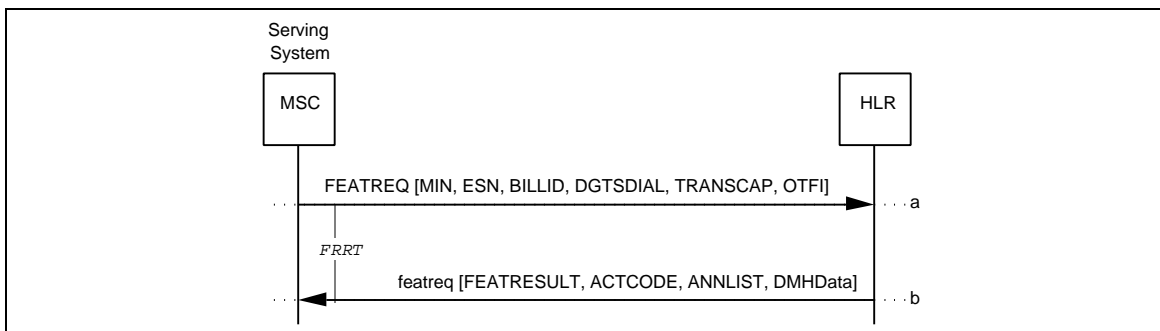

Figure 23 Direct FeatureRequest without Call Routing

- a. A feature code string (i.e., a string of digits including a feature code) received from a served MS are included in a FEATREQ and sent by the Serving MSC to the HLR associated with the MS.

Parameters	Usage	Type
MIN	Served MS MIN.	R
ESN	Served MS ESN.	R
BILLID	Call ID. Used for billing and redirection purposes when FEATREQ results in call routing.	R
DGTSDIAL	Feature code string entered by served MS.	R
TRANSCAP	Indicates the serving system's transaction capability at the current time.	R
OTFI	Indicates the current feature activation status.	O
ChargingAreaInformation	Indicates charge area for the served MS.	O
CarrierIdentificationCode	Indicates carrier identification code for the served MS.	O

*
*
*

- b. The HLR determines the appropriate feature treatment based on the received information and returns this in a featreq. In this scenario, the response from the HLR does not include instructions for the serving system to set up the call.

Parameters	Usage	Type
FEATRESULT	Feature request result.	R
ACTCODE	Treatment for served MS. If not included, treatment is based on FEATRESULT value.	O
ANMLIST	List of tones or announcements to play. If not included, announcement is based on FEATRESULT value.	O
DMHData:	Data for DMH recording purposes:	
[DMH_AccountCode-Digits]	Include if applicable.	O
[DMH_AlternateBilling-Digits]	Include if applicable.	O
[DMH_BillingDigits]	Include if applicable.	O
[MobileDirectory-Number]	Include if applicable.	O

4.9.2 Direct FeatureRequest with Call Routing

This operation scenario describes a normal FeatureRequest operation when the response from the HLR includes instructions for the serving system to set up the call.

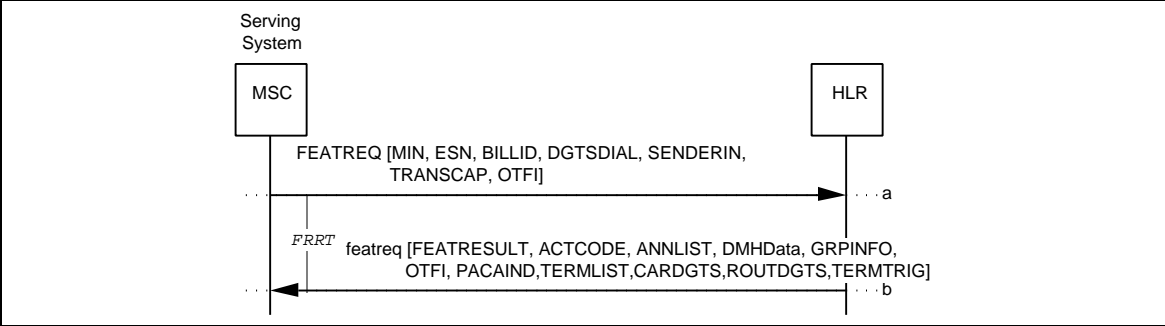

Figure 24 Direct FeatureRequest with Call Routing

1
2
3
4
5
6
7
8
9
10
11
12
13
14
15
16
17
18
19
20
21
22
23
24
25
26
27
28
29
30
31
32
33
34
35
36
37
38
39
40
41
42
43
44
45
46
47
48
49
50
51
52
53
54
55
56
57
58
59
60

- a. A feature code string (i.e., a string of digits including a feature code) received from a served MS are included in a FEATREQ and sent by the Serving MSC to the HLR associated with the MS.

Parameters	Usage	Type
MIN	Served MS MIN.	R
ESN	Served MS ESN.	R
BILLID	Call ID. Used for billing and redirection purposes when FEATREQ results in call routing.	R
DGTSDIAL	Feature code string entered by served MS.	R
SENDERIN	Identification number of the sending node.	R
TRANSCAP	Indicates the serving system's transaction capability at the current time.	R
OTFI	Indicates the current feature activation status.	O
ChargingAreaInformation	Indicates charge area for the served MS.	O
CarrierIdentificationCode	Indicates carrier identification code for the served MS.	O

*
*
*

- b. The HLR determines the appropriate feature treatment based on the received information and returns this in a featreq. In this scenario, the response from the HLR includes instructions for the serving system to set up the call.

Parameters	Usage	Type
FEATRESULT	Feature request result.	R
TERMLIST	Call termination information.	R
ACTCODE	Treatment for served MS. If not included, treatment is based on FEATRESULT value.	O
ANMLIST	List of tones or announcements to play. If not included, announcement is based on FEATRESULT value.	O
DMHData:	Data for DMH recording purposes:	
[DMH_AccountCode-Digits]	Include if applicable.	O
[DMH_AlternateBilling-Digits]	Include if applicable.	O
[DMH_BillingDigits]	Include if applicable.	O
[MobileDirectory-Number]	Include if applicable.	O
GRPINFO	Information associated with group routing.	O
OTFI	Indicates the current feature activation status.	O
PACAIND	Indicates PACA priority level.	O
CARDGTS	Calling subscriber's PIC. Include if applicable and if not specified within the TerminationList parameter.	O

1
2
3
4
5
6
7
8
9
10
11
12
13
14
15
16
17
18
19
20
21
22
23
24
25
26
27
28
29
30
31
32
33
34
35
36
37
38
39
40
41
42
43
44
45
46
47
48
49
50
51
52
53
54
55
56
57
58
59
60

ROUTDGTS	Special routing instructions. Include if applicable and if not specified within the TerminationList parameter.	O
TERMTRIG	Indicates active termination trigger points.	O

4.10 FlashRequest

The FlashRequest (FLASHREQ) operation is used by the Serving MSC to forward a flash received from a MS engaged in a voice call towards the Anchor MSC (possibly via one or more Tandem MSCs).

The following table lists the valid combinations of invoking and responding FEs.

Table 11 FE Combinations for FLASHREQ

	INVOKING FE	RESPONDING FE
Case 1	Serving MSC	Anchor MSC
Case 2	Serving MSC	Tandem MSC
Case 3	Tandem MSC	Tandem MSC
Case 4	Tandem MSC	Anchor MSC

4.10.1 Successful FlashRequest

This scenario describes the normal use of the FlashRequest operation.

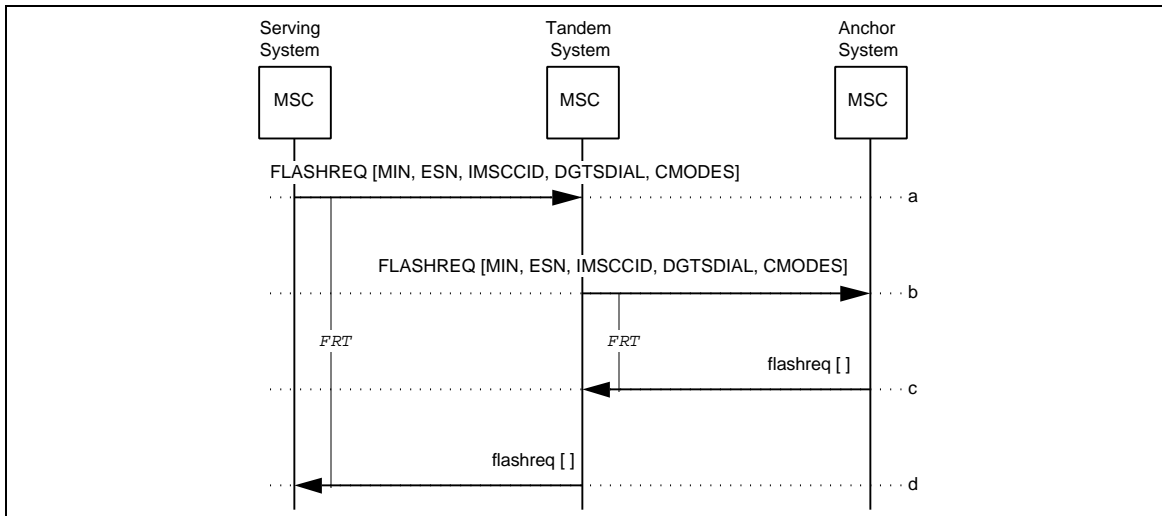

Figure 25 Successful FlashRequest

- 1
2
3 a. When the Serving MSC receives a flash from a MS engaged in a voice call, it sends a
4 FLASHREQ toward the Anchor MSC in the call (in this scenario, via a Tandem MSC).

Parameters	Usage	Type
MIN	Served MS MIN.	R
ESN	Served MS ESN.	R
IMSCCID	Specifies the trunk in a dedicated trunk group between the two MSCs for the call involved.	R
DGTSDIAL	Feature code string entered by served MS.	R
CMODES	Actual ConfidentialityModes. Include if the SMEKEY was provided to the Serving MSC.	O

- 5
6
7
8
9
10
11
12
13
14
15
16
17 b. The Tandem MSC adjusts the InterMSCCircuitID to identify the circuit between it and
18 the Anchor MSC, and forwards the FLASHREQ to the Anchor MSC.

19
20 When the Anchor MSC receives the FLASHREQ, it may act on the feature request
21 from the served MS.

- 22 c. The Anchor MSC returns a flashreq to the Tandem MSC.
23
24 d. The Tandem MSC returns a flashreq to the Serving MSC.
25
26
27
28
29
30
31
32
33
34
35
36
37
38
39
40
41
42
43
44
45
46
47
48
49
50
51
52
53
54
55
56
57
58
59
60

4.11 InformationDirective

The InformationDirective (INFODIR) operation is used by the HLR to direct the serving system to provide a specified notification to an idle MS.

The following table lists the valid combinations of invoking and responding FEs.

Table 12 FE Combinations for INFODIR

	INVOKING FE	RESPONDING FE
Case 1	HLR	Serving VLR
Case 2	Serving VLR	Serving MSC

4.11.1 Successful InformationDirective

This operation scenario describes a normal InformationDirective operation.

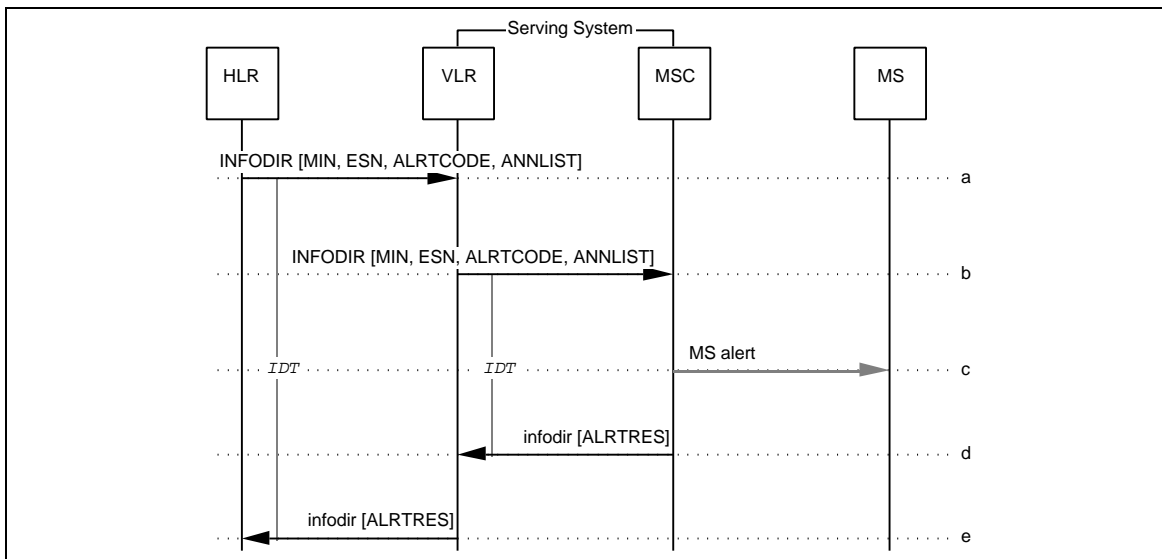

Figure 26 Successful InformationDirective

1
2
3
4
5
6
7
8
9
10
11
12
13
14
15
16
17
18
19
20
21
22
23
24
25
26
27
28
29
30
31
32
33
34
35
36
37
38
39
40
41
42
43
44
45
46
47
48
49
50
51
52
53
54
55
56
57
58
59
60

- a. After determining that a roaming MS should be given a particular notification, the HLR sends an I NFODI R to the Serving VLR.

Parameters	Usage	Type
MIN	Served MS MIN.	R
ESN	Served MS ESN.	R
ALRTCODE	Type of alert signal to apply. Include if MS is to be alerted.	O
ANMLIST	List of tones or announcements to play. Include if applicable.	O

- b. The VLR forwards the I NFODI R to the Serving MSC. Parameters are as in Step -a.
- c. The MSC notifies the specified MS in an appropriate fashion. No action may be possible if the MS is in a call or is unavailable.
- d. The Serving MSC sends an i nfodi r to the Serving VLR. This may contain an indication of the result of the MS notification.

Parameters	Usage	Type
ALRTRES	Result of notification attempt. Included if ALRTCODE in Step-a requested a result.	O
ChargingAreaInformation	Indicates charge area for the served MS.	O
CarrierIdentificationCode	Indicates carrier identification code for the served MS.	O

*
*
*

- e. The Serving VLR forwards the i nfodi r to the HLR.

4.12 InformationForward

The InformationForward (INFOFWD) operation is used by the Anchor MSC to transfer information concerning the served MS to the Serving MSC after handoff (e.g., a message waiting status change).

The following table lists the valid combinations of invoking and responding FEs.

Table 13 FE Combinations for INFOFWD

	INVOKING FE	RESPONDING FE
Case 1	Anchor MSC	Serving MSC
Case 2	Anchor MSC	Tandem MSC
Case 3	Tandem MSC	Serving MSC

4.12.1 Successful InformationForward

This scenario describes the successful use of the InformationForward operation.

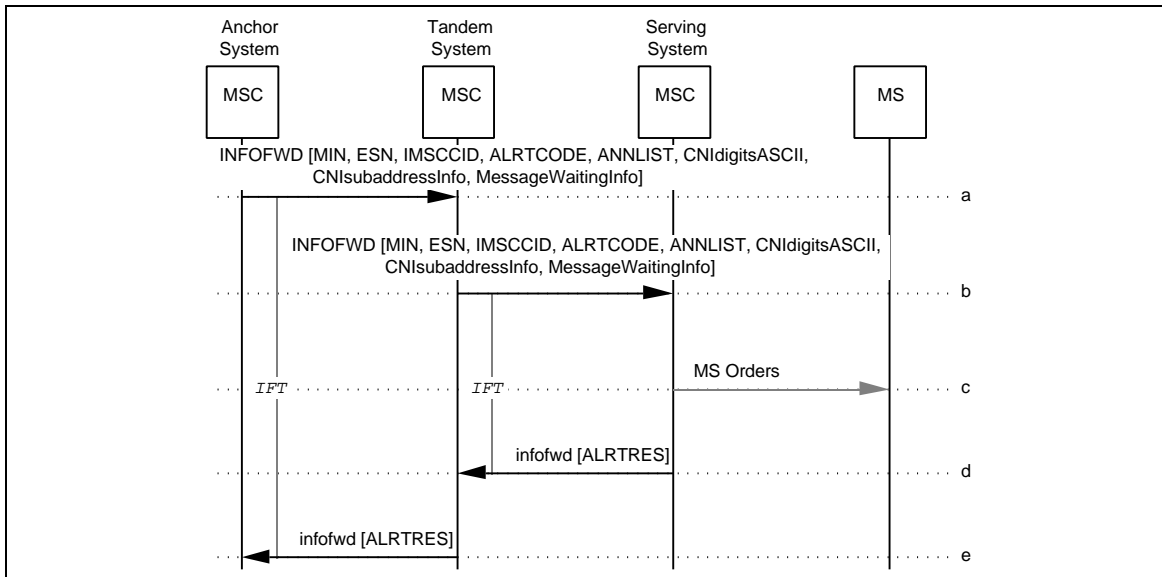

Figure 27 Successful InformationForward

- 1
2
3 a. Following an intersystem handoff, the Anchor MSC receives information destined for
4 the served MS (e.g., an indication to alert the MS); therefore, it sends an I NFOFWD to
5 the Tandem MSC.

Parameters	Usage	Type
MIN	Served MS MIN.	R
ESN	Served MS ESN.	R
IMSCCID	Specifies the trunk in a dedicated trunk group between the two MSCs for the call involved.	R
ALRTCODE	Type of alert signal to apply. Include if MS is to be alerted.	O
ANNLIST	List of tones or announcements to play. Include if applicable.	O
CNI digits ASCII:	CNI digits parameters in ASCII format. Include if available. Includes:	
[CallingPartyNumber-String1]	Calling number digits (network-provided), incl. presentation restriction information.	O
[CallingPartyNumber-String2]	Calling number digits (user-provided), incl. presentation restriction information.	O
[RedirectingNumber-String]	Redirecting number digits, incl. presentation restriction information.	O
CNI subaddress info:	CNI subaddress information. Include if available. Includes:	
[CallingPartySubaddress]	Calling number subaddress (user-provided).	O
[RedirectingSubaddress]	Redirecting number subaddress.	O
Message Waiting info:	Message Waiting information. Include if available. Includes:	
[MessageWaiting-NotificationCount]	Include if MessageWaitingNotificationType is <i>Count Indication</i> .	O
[MessageWaiting-NotificationType]	Include if Message Waiting Notification feature is active and an action is required..	O

- 18
19
20
21
22
23
24
25
26
27
28
29
30
31
32
33
34
35
36
37
38
39
40
41 b. The Tandem MSC adjusts the InterMSCCircuitID to identify the circuit between it and
42 the Serving MSC, and forwards the I NFOFWD to the Serving MSC. Parameters are
43 as in Step-a.
44
45 c. The Serving MSC notifies the specified MS in an appropriate fashion.
46
47 d. The Serving MSC acknowledges receipt by sending an i nfofwd to the Tandem
48 MSC.

ALRTRES	Indicates whether or not alerting was successfully applied.	O
---------	---	---

- 49
50
51
52 e. The Tandem MSC forwards the i nfofwd to the Anchor MSC. The parameters are
53 as in step-d.
54
55
56
57
58
59
60

4.13 InterSystemAnswer

The InterSystemAnswer (ISANSWER) operation is used to convey an answer indication.

NOTE: The ISANSWER message is also used following a handoff of an MS that is alerting or awaiting answer (see *TIA/EIA-41* Chapter 2).

The following table lists the possible combinations of invoking and responding FEs.

Table 14 FE Combinations for ISANSWER

	INVOKING FE	RESPONDING FE
Case 1	Anchor MSC	Serving MSC
Case 2	Serving MSC	Anchor MSC

4.13.1 Successful InterSystemAnswer

This operation scenario describes a successful InterSystemAnswer operation.

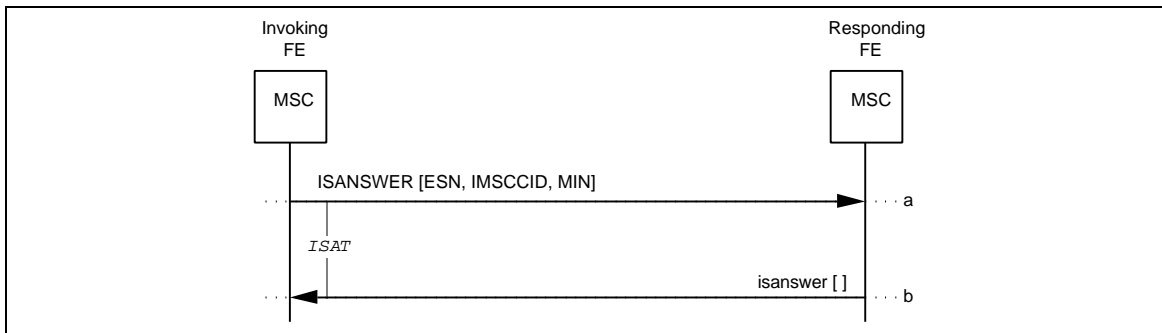

Figure 28 Successful InterSystemAnswer

- a. The Invoking FE sends an **I SANSWER** to the Responding FE, indicating that the call has been answered.

Parameters	Usage	Type
ESN	Electronic Serial Number of the Served MS.	R
IMSCCID	Identifies a specific trunk in the trunk group between the two MSCs.	R
MIN	Served MS MIN.	R

- b. The Responding FE acknowledges receipt of the **I SANSWER** by sending an empty **i sanswer** to the Invoking FE.

4.14 InterSystemPage

The InterSystemPage (ISPAGE) operation is used by a Serving MSC to request a Border MSC to either (a) page an MS, or (b) listen for a page response from an MS, in the border system.

The following table lists the valid combinations of invoking and responding FEs.

Table 15 FE Combinations for ISPAGE

	INVOKING FE	RESPONDING FE
Case 1	Serving MSC	Border MSC

One of several possible results is returned:

1. Routing information in the form of a TLDN on the Border MSC.
2. An indication that access to the identified MS is denied with reason for denial (e.g., due to an MS busy condition, no page response, or unavailable).
3. An error indicating the transaction cannot be completed.

4.14.1 Successful InterSystemPage: Border MSC Routing Information Returned

This operation scenario describes the InterSystemPage operation when the response provides routing information to the MS on the Border MSC.

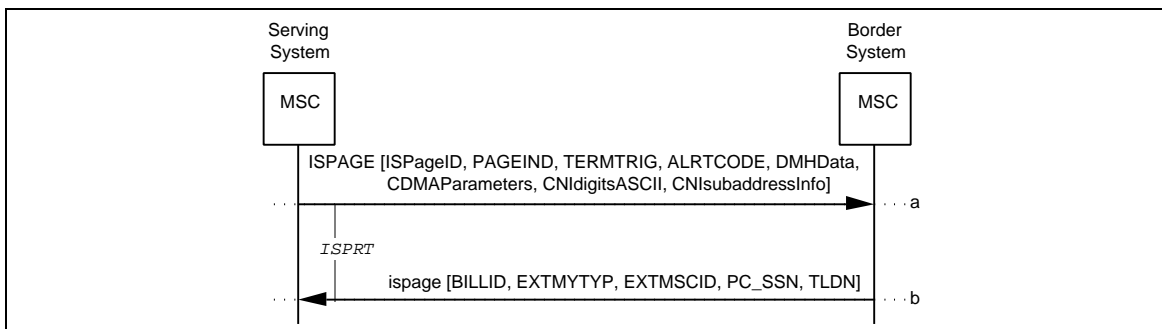

Figure 29 Successful InterSystemPage: Border MSC Routing Information Returned

- a. The Serving MSC sends an ISPAGE to the Border MSC, including an indication of the area where the MS's presence was last detected, an indication of whether to page or just listen for an unsolicited page response, and other relevant parameters.

Parameters	Usage	Type
ISPageID:	Set of identification parameters in ISPAGE:	
[BillingID]	Originating Call ID. Used for billing and redirection purposes when ISPAGE results in call routing.	R
[MIN]	Served MS MIN.	R
[ESN]	Served MS ESN.	R
[MSCID]	Originating MSC MSCID.	R
[LocationAreaID]	Served MS LocationAreaID for paging purposes. Include if available.	O
[ExtendedSystemMy-TypeCode]	Serving MSC vendor identification.	O
[ExtendedMSCID]	Serving MSC MSCID.	O
[SystemMyTypeCode]	Originating MSC vendor identification.	O
[MSCIN]	Identifies Originating MSC.	O
[PC_SSN]	Originating MSC PC_SSN. Include if SS7 carriage services are used.	O
PAGEIND	Type of page request. Include if listen only.	O
TERMTRIG	Termination trigger points currently active for the MS. Include if applicable.	O
ALRTCODE	Type of alert signal to apply. Include if special alerting is to be applied to the MS.	O
CDMAParameters:	Set of CDMA-specific parameters in ISPAGE:	
[CDMASlotCycleIndex]	Include when MS is operating in CDMA Slotted Mode.	O
[CDMAStationClass-Mark]	Include if a CDMA channel is in use.	O
CNIdigitsASCII:	CNI digits parameters in ASCII format. Include if available. Includes:	
[CallingPartyNumber-String1]	Calling number digits (network-provided), incl. presentation restriction information.	O
[CallingPartyNumber-String2]	Calling number digits (user-provided), incl. presentation restriction information.	O
[RedirectingNumber-String]	Redirecting number digits, incl. presentation restriction information.	O
CNIsubaddressInfo:	CNI subaddress information. Include if available. Includes:	
[CallingPartySubaddress]	Calling number subaddress (user-provided).	O
[RedirectingSubaddress]	Redirecting number subaddress.	O

continued on next page...

1
2
3 ...continued from previous page
4

Parameters	Usage	Type
DMHData:	Data for <i>DMH</i> recording purposes:	
[DMH_AccountCode-Digits]	Include if applicable.	O
[DMH_AlternateBilling-Digits]	Include if applicable.	O
[DMH_BillingDigits]	Include if applicable.	O
[MobileDirectory-Number]	Include if applicable.	O

- 5
6
7
8
9
10
11
12
13
14
15
16
17 b. The Border MSC determines that the MS is present, assigns it to a voice/traffic
18 channel, allocates it a TLDN, and returns this information to the Originating MSC in
19 the *i* spage.
20

Parameters	Usage	Type
BILLID	Terminating billing ID for recording purposes.	R
EXTMYTYP	Border MSC vendor identification.	O
EXTMSCID	Border MSC MSCID.	R
PC_SSN	Border MSC PC_SSN. Include if SS7 carriage services are used.	O
TLDN [DGTSDEST]	Destination digits for use in inter-MSC call routing.	R

21
22
23
24
25
26
27
28
29
30
31
32
33
34
35
36
37
38
39
40
41
42
43
44
45
46
47
48
49
50
51
52
53
54
55
56
57
58
59
60

4.14.2 Unsuccessful InterSystemPage: Border MSC Access Denied

This operation scenario describes the InterSystemPage operation when access is denied.

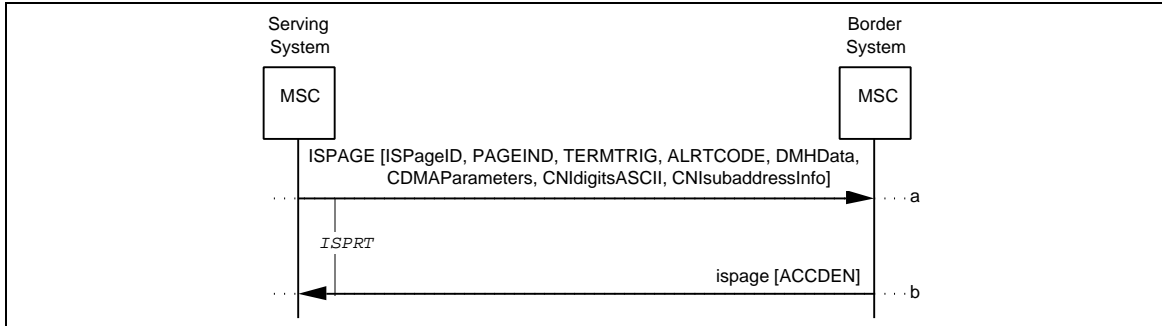

Figure 30 Unsuccessful InterSystemPage: Border MSC Access Denied

- a. Same as Section 4.14.1, Step-a.
- b. The Border MSC determines that access cannot be granted to the MS for some reason (e.g., busy condition, no response to the page, or unavailable) and returns this indication to the Originating MSC in the *i*spage.

Parameters	Usage	Type
ACCDEN	Border MSC's reason for denying access.	R

4.14.3 Unsuccessful InterSystemPage: Border MSC Resource Shortage

This operation scenario describes the InterSystemPage operation when response is an error indicating a resource shortage in the Border MSC.

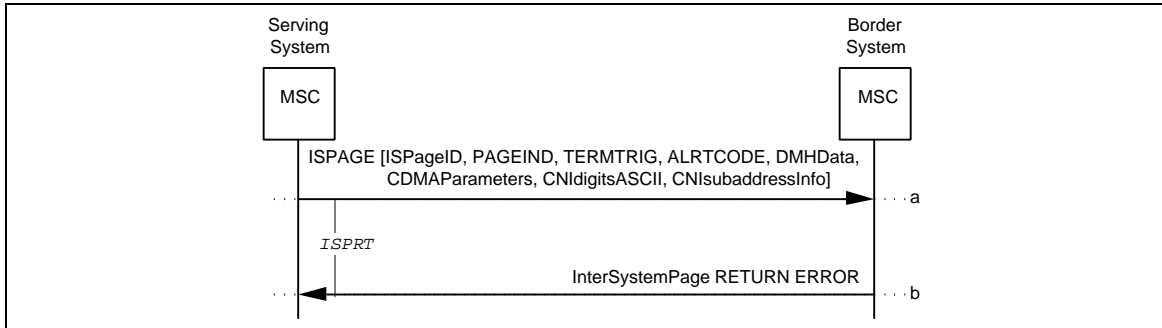

Figure 31 Unsuccessful InterSystemPage: Border MSC Resource Shortage

- a. Same as Section 4.14.1, Step-a.
- b. The Border MSC has a resource shortage or determines that the MS is present, but cannot allocate it a TLDN due to a resource shortage. It returns this indication to the Serving MSC via an InterSystemPage RETURN ERROR component, indicating *ResourceShortage*.

4.15 InterSystemPage2

The InterSystemPage2 (ISPAGE2) operation is used by a Serving MSC that has received a call via a TLDN to request a Border MSC to either (a) page an MS, or (b) listen for a page response from an MS, in the border system.

The following table lists the valid combinations of invoking and responding FEs.

Table 16 FE Combinations for ISPAGE2

	INVOKING FE	RESPONDING FE
Case 1	Serving MSC	Border MSC

One of several possible results is returned:

1. An indication that identified MS's presence is confirmed in the Border MSC. Include indication if authentication should be performed for MS.
2. An indication that access to the identified MS is denied with reason for denial (e.g., due to an MS busy condition, no page response, or unavailable).
3. An error indicating the transaction cannot be completed.

4.15.1 Successful InterSystemPage2: MS Presence Confirmed in Border MSC

This operation scenario describes the InterSystemPage2 operation when the response indicates that the MS's presence has been successfully confirmed in the Border MSC.

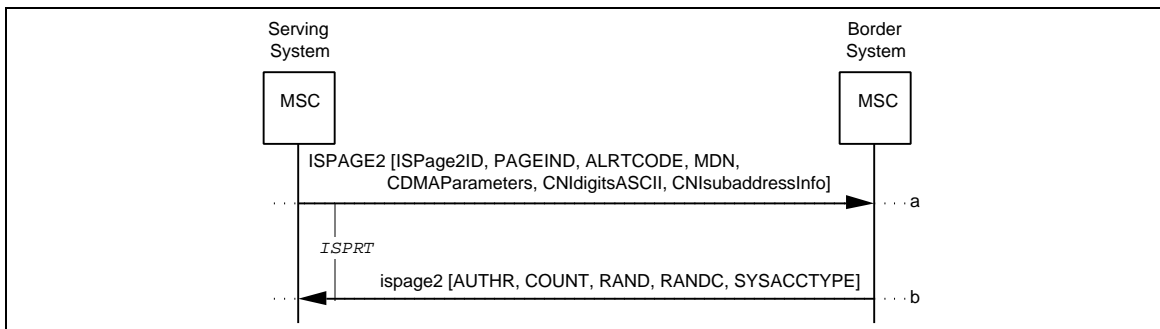

Figure 32 Successful InterSystemPage2: MS Presence Confirmed in Border MSC

- a. The Serving MSC sends an ISPAGE2 to the Border MSC, including an indication of the area where the MS's presence was last detected, an indication of whether to page or just listen for an unsolicited page response, and other relevant parameters. If the MS is a CDMA MS, appropriate parameters necessary for paging the MS are included.

Parameters	Usage	Type
ISPage2ID:	Set of identification parameters in ISPAGE2:	
[BillingID]	Originating Call ID. Used for billing and redirection purposes when ISPAGE2 results in call routing.	R
[MIN]	Served MS MIN.	R
[ESN]	Served MS ESN.	R
[LocationAreaID]	Served MS LocationAreaID for paging purposes. Included if available.	O
PAGEIND	Type of page request. Include if listen only.	O
ALRTCODE	Type of alert signal to apply. Include if special alerting is to be applied to the MS.	O
MDN	Mobile directory number. Include if available.	O
CDMAParameters:	Set of CDMA-specific parameters in ISPAGE:	
[CDMASlotCycleIndex]	Include when MS is operating in CDMA Slotted Mode.	O
[CDMAStationClass-Mark]	Include if a CDMA channel is in use.	O
CNI digitsASCII:	CNI digits parameters in ASCII format. Include if available. Includes:	
[CallingPartyNumber-String1]	Calling number digits (network-provided), incl. presentation restriction information.	O
[CallingPartyNumber-String2]	Calling number digits (user-provided), incl. presentation restriction information.	O
[RedirectingNumber-String]	Redirecting number digits, incl. presentation restriction information.	O
CNIsubaddressInfo:	CNI subaddress information. Include if available. Includes:	
[CallingPartySubaddress]	Calling number subaddress (user-provided).	O
[RedirectingSubaddress]	Redirecting number subaddress.	O

- b. The Border MSC determines that the MS is present, assigns it to a voice/traffic channel, determines if authentication should be performed, and returns this information to the Serving MSC in the *i* spage2.

Parameters	Usage	Type
AUTHR	Include if received from MS.	O
COUNT	Include if received from MS.	O
RAND	Include if RANDC from MS matches RANDC derived from RAND in Border MSC.	O
RANDC	8 most significant bits of RAND. Include if received from MS.	O
SYSACCTYPE	Type of system access. Include if MS is available.	O

4.15.2 Unsuccessful InterSystemPage2: Access Denied

This operation scenario describes the InterSystemPage2 operation when access is denied.

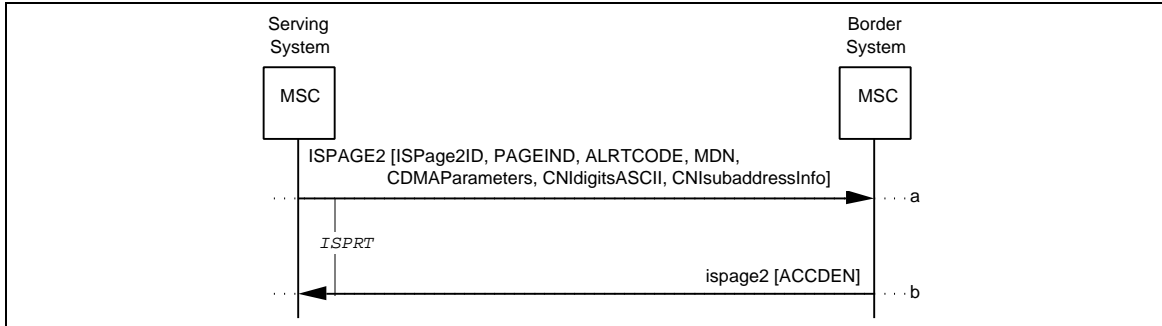

Figure 33 Unsuccessful InterSystemPage2: Access Denied

- a. Same as Section 4.15.1, Step-a.
- b. The Border MSC determines that access cannot be granted to the MS, either due to a busy condition, no response to the page, or unavailable, and returns this indication to the Serving MSC in the *ispage2*.

Parameters	Usage	Type
ACCDEN	Reason for denying access.	R

4.15.3 Unsuccessful InterSystemPage2: Resource Shortage

This operation scenario describes the InterSystemPage2 operation when the response is an error indicating a resource shortage in the Border MSC.

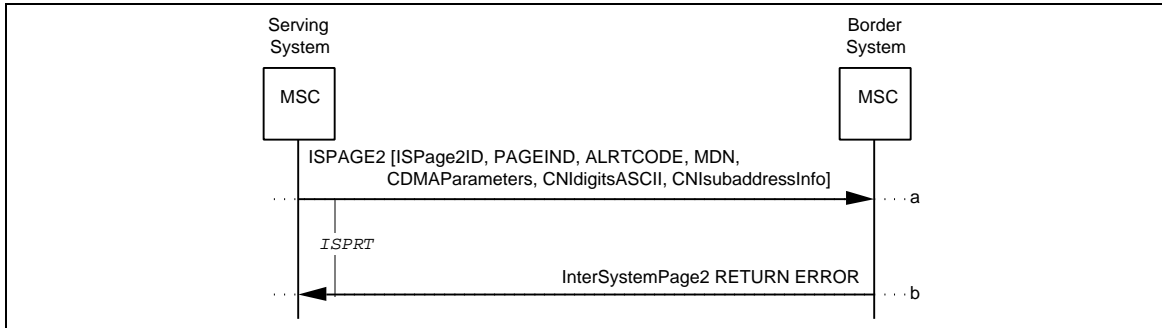

Figure 34 Unsuccessful InterSystemPage2: Resource Shortage

- a. Same as Section 4.15.1, Step-a.
- b. The Border MSC has a resource shortage. It returns this indication to the Serving MSC via an InterSystemPage2 RETURN ERROR component, indicating *ResourceShortage*.

4.16 InterSystemSetup

The InterSystemSetup (ISSETUP) operation is used by the Serving MSC to request the Border MSC to perform Call Setup actions by connecting the voice channel in which mobile confirmation has been received to the intersystem trunk facility specified by the serving MSC.

The following table lists the valid combinations of invoking and responding FEs.

Table 17 FE Combinations for ISSETUP

	INVOKING FE	RESPONDING FE
Case 1	Serving MSC	Border MSC

One of several possible results is returned:

1. Notification that the request was successful.
2. Notification that the request was unsuccessful (e.g., path between voice channel/intersystem trunk cannot be completed).

4.16.1 Successful InterSystemSetup

This scenario describes the successful use of the InterSystemSetup operation.

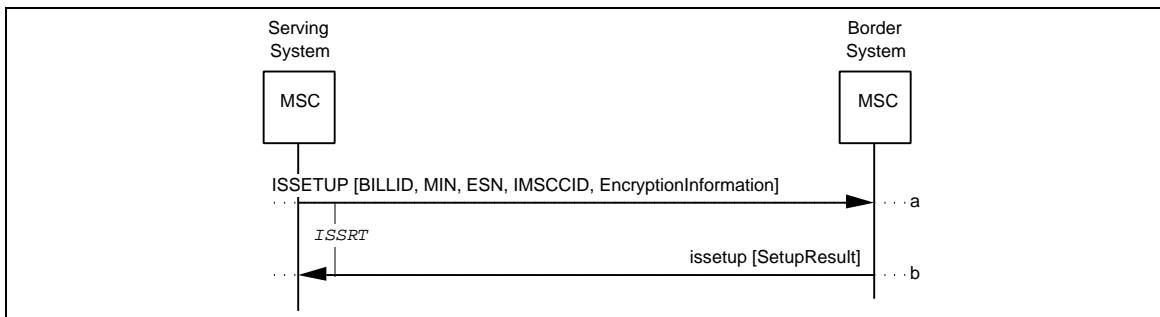

Figure 35 Successful InterSystemSetup

- 1
2
3
4
5
6
- a. The Serving MSC determines Call Setup actions should be performed with the border system. It sends an **ISSETUP** to the Border MSC, directing the Border MSC to seize the specified intersystem trunk.

7
8
9
10
11
12
13
14
15
16
17
18
19
20
21
22
23

Parameters	Usage	Type
BILLID	Call ID. Used for billing and to identify the Anchor MSC.	R
MIN	Served MS MIN.	R
ESN	Served MS ESN.	R
IMSCCID	Specifies a trunk in a dedicated trunk group between the two MSCs	R
EncryptionInformation:		
[CDMAPLCM]	CDMAPrivateLongCodeMask. Include if available.	O
[SMEKEY]	SignalingMessageEncryptionKey. Include if available.	O
[VPMASK]	VoicePrivacyMask. Include if available.	O

- 24
25
26
27
28
- b. If the specified trunk is available, the Border MSC increases the Segment Counter in the received BillingID parameter by one and uses the updated BillingID for the new call segment. The Border MSC returns an **issetup** to the serving MSC, completing the transaction.

29
30
31
32
33
34
35
36
37
38
39
40
41
42
43
44
45
46
47
48
49
50
51
52
53
54
55
56
57
58
59
60

Parameters	Usage	Type
SetupResult	Indicates that the InterSystemSetup operation was successful (in this case).	R

4.16.2 Unsuccessful InterSystemSetup

This operation scenario describes the InterSystemSetup operation when the response is an error indicating a resource shortage in the Border MSC.

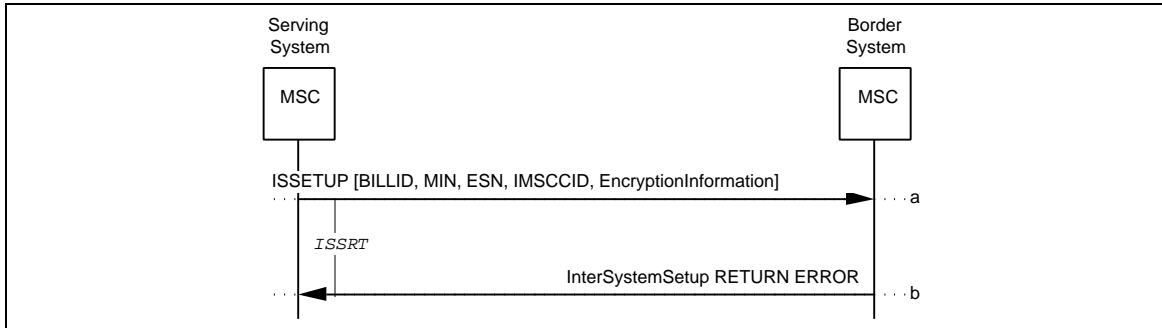

Figure 36 Unsuccessful InterSystemSetup

- a. Same as Section 4.16.1., Step-a.
- b. If an intersystem trunk is not available, the Border MSC returns an InterSystemSetup RETURN ERROR component to the requesting MSC, indicating *ResourceShortage*.

4.17 LocationRequest

The LocationRequest (LOCREQ) operation is used by an Originating MSC to obtain call treatment instructions from the HLR. The call is identified by the dialed mobile address digits received by the Originating MSC.

The following table lists the valid combinations of invoking and responding FEs.

Table 18 FE Combinations for LOCREQ

	INVOKING FE	RESPONDING FE
Case 1	Originating MSC	HLR

One of several possible results is returned:

1. Routing information in the form of a PSTN directory number.
2. Routing information in the form of an MS on the local MSC.
3. Routing information in the form of an MS on an intersystem MSC.
4. Routing information in the form of an MS on an intersystem MSC along with an indication that access to the called party is denied with reason for denial (e.g., due to an MS busy condition).
5. Routing information involving multiple terminations, including PSTN, local and intersystem terminations.
6. An indication that access to the called party is denied with reason for denial (e.g., due to an MS busy condition) with or without routing information.

4.17.1 Successful LocationRequest: Route to a PSTN DN

This operation scenario describes the LocationRequest operation when call treatment is to route the call to a PSTN directory number.

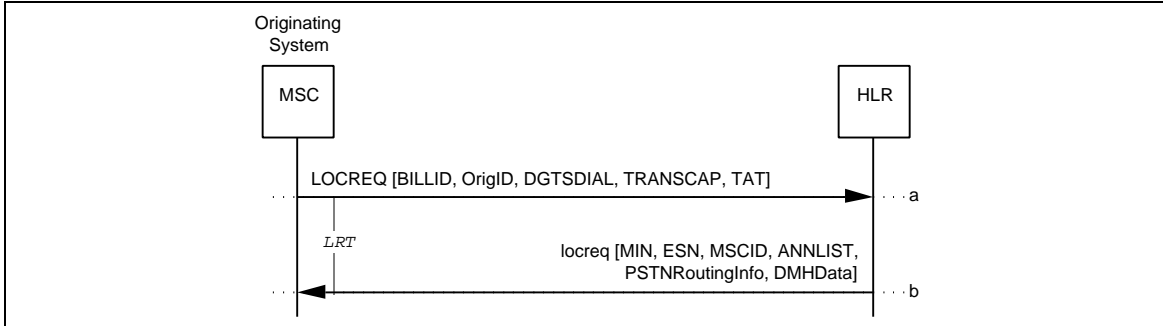

Figure 37 Successful LocationRequest: Route to a PSTN DN

- a. The Originating MSC sends a LOCREQ to the HLR associated with the MS; this association is made through the dialed MS address digits (which may not be the MIN).

Parameters	Usage	Type
BILLID	Call ID. Used for billing and redirection purposes when LOCREQ results in call routing.	R
OrigID: [MSCID] [PC_SSN] [SystemMyTypeCode]	Originating MSC's identification information: Originating MSC MSCID. Originating MSC PC_SSN. Include if SS7 carriage services are used. Originating MSC vendor identification.	R O MBC
DGTSDIAL	Digits identifying called party.	R
TRANSCAP	Indicates the originating system's transaction capability at the current time.	O
TAT	TerminationAccessType identifying special access situations. Include if applicable.	O

- b. The HLR determines that the call shall be routed to a PSTN directory number and returns this information to the Originating MSC in the `Locreq`.

Parameters	Usage	Type
MIN	Called MS MIN.	R
ESN	Called MS ESN.	R
MSCID	Serving MSC's MSCID.	R
ANMLIST	List of tones or announcements to play. If not included, announcement is based on other parameters in response.	O
PSTNRoutingInfo:	Call routing information:	
[TerminationList]	Network termination information. Include if TerminationList is allowed.	O
[Digits(Destination)]	PSTN DN for use in call routing. Include if TerminationList is not allowed.	O
[RoutingDigits]	Special routing instructions. Include if applicable and if not specified within the TerminationList parameter.	O
[Digits(Carrier)]	Called subscriber's PIC. Include if applicable and if not specified within the TerminationList parameter.	O
DMHData:	Data for <i>DMH</i> recording purposes:	
[DMH_AccountCode-Digits]	Include if applicable.	O
[DMH_AlternateBilling-Digits]	Include if applicable.	O
[DMH_BillingDigits]	Include if applicable.	O
[MobileDirectory-Number]	Include if applicable.	O
[DMH_Redirection-Indicator]	Include if applicable.	R
ChargingAreaInformation	Indicates charge area for the called MS.	O
CarrierIdentificationCode	Indicates carrier identification code for the called MS.	O
MobileAdditionalParty'sCategory3	Indicates information concerning billing system for the called MS.	O

*
*
*
*

4.17.2 Successful LocationRequest: Route to a Local MS

This operation scenario describes the LocationRequest operation when call treatment is to route the call to a local MS (i.e., an MS served by the Originating MSC).

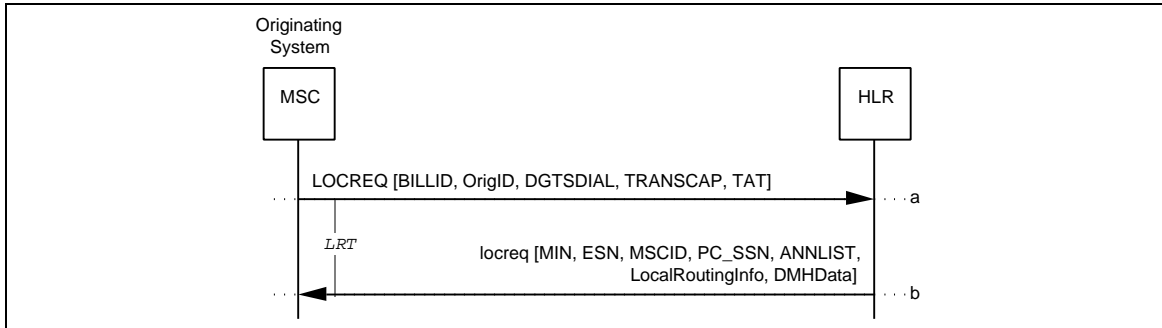

Figure 38 Successful LocationRequest: Route to a Local MS

- a. Same as Section 4.17.1, Step-a.
- b. The HLR determines that the call shall be routed to a local MS (i.e., an MS served by the Originating MSC) and returns this information to the Originating MSC in the lcreq.

Parameters are as in Section 4.18.1, Step-b, with the exception that PSTNRoutingInfo is not included and with the following additions:		
Parameters	Usage	Type
PC_SSN	Originating MSC PC_SSN. Include if SS7 carriage services are used.	O
LocalRoutingInfo:	Call routing information:	
[TerminationList]	Local termination information. Include if TerminationList is allowed.	O
[Digits(Destination)]	Destination digits for use in intra-MSC call routing (may be MS's MIN). Include if applicable and if TerminationList is not allowed.	O
[RoutingDigits]	Special routing instructions. Include if applicable and if not specified within the TerminationList parameter.	O
[Digits(Carrier)]	Called subscriber's PIC for use in intra-MSC call routing. Include if applicable and if not specified within the TerminationList parameter.	O

4.17.3 Successful LocationRequest: Route to an MS on Another MSC

This operation scenario describes the LocationRequest operation when call treatment is to route the call to an MS on an MSC other than the Originating MSC.

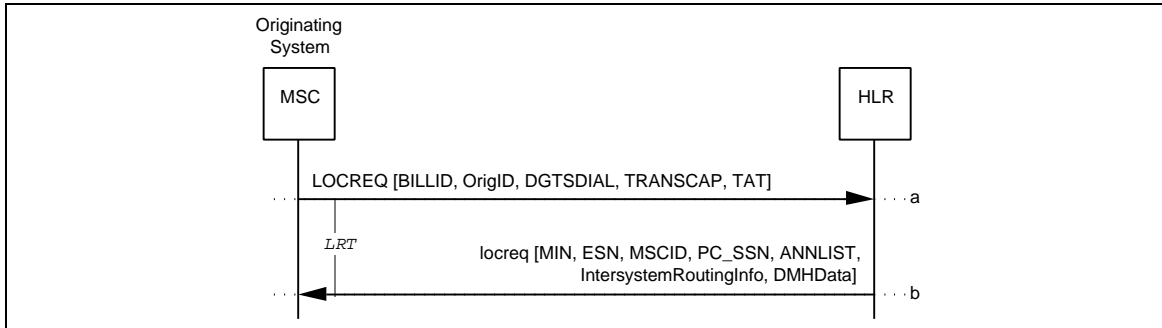

Figure 39 Successful LocationRequest: Route to an MS on Another MSC

- a. Same as Section 4.17.1, Step-a.
- b. The HLR determines that the call shall be routed to an MS on another MSC and returns this information to the Originating MSC in the lcreq.

Parameters are as in Section 4.17.1, Step-b, with the exception that PSTNRoutingInfo is not included and with the following additions:		
Parameters	Usage	Type
PC_SSN	Serving MSC PC_SSN. Include if SS7 carriage services are used.	O
IntersystemRoutingInfo:	Call routing information:	
[TerminationList]	Intersystem termination information. Include if TerminationList is allowed.	O
[Digits(Destination)]	Destination digits for use in inter-MSC call routing. Include if TerminationList is not allowed.	O
[RoutingDigits]	Special routing instructions. Include if applicable and if not specified within the TerminationList parameter.	O
[Digits(Carrier)]	Called subscriber's PIC for use in inter-MSC call routing. Include if applicable and if not specified within the TerminationList parameter.	O

4.17.4 Successful LocationRequest: Routing Information and Access Denied Indication Returned

This operation scenario describes the LocationRequest operation when an access denied indication is returned along with routing information.

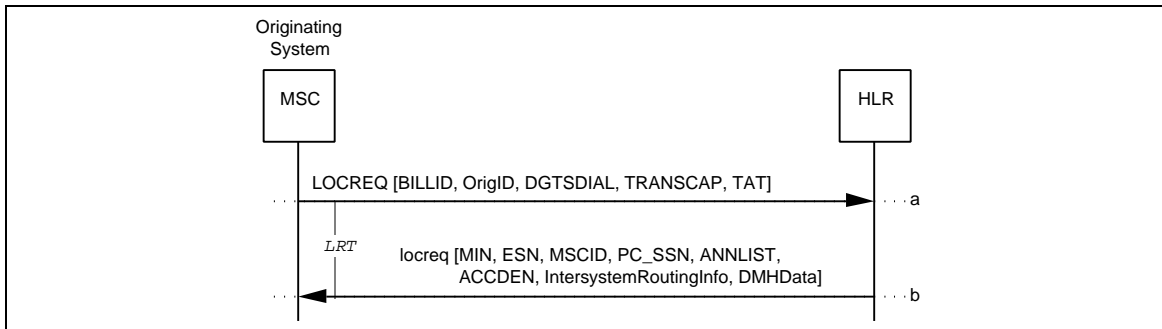

Figure 40 Successful LocationRequest: Routing Information and Access Denied Indication Returned

- a. Same as Section 4.17.1, Step-a.
- b. The HLR determines that access cannot be granted to the MS but, due to the operating environment, routing information must be returned in the `Locreq`.

Parameters are as in Section 4.17.3, Step-b, with the following addition:		
Parameters	Usage	Type
ACCDEN	Indicates reason for denying access. Include based on operating environment.	O

4.17.5 Successful LocationRequest: Route to Multiple Terminations

This operation scenario describes the LocationRequest operation when call treatment is to route the call to one or more MSs on another MSC.

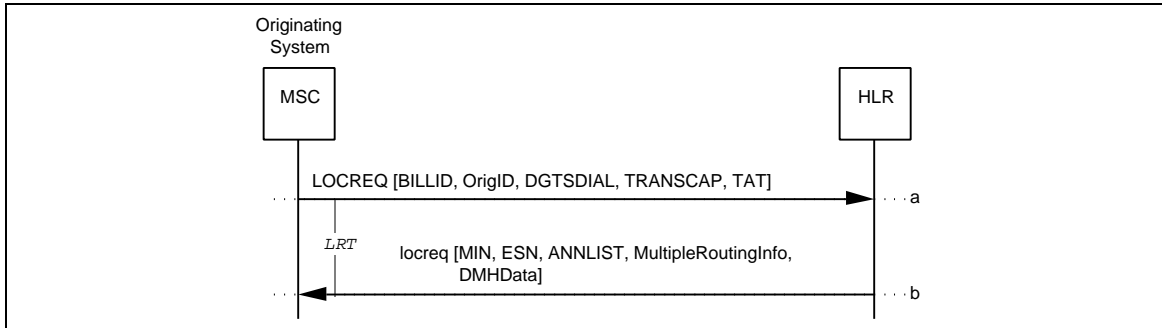

Figure 41 Successful LocationRequest: Route to Multiple Terminations

a. Same as Section 4.17.1, Step-a.

Parameters are as in Section 4.17.1, Step -a, with the following exception:		
Parameters	Usage	Type
TRANSCAP	Indicates the originating system's transaction capability at the current time. Must indicate support for multiple terminations.	R

b. The HLR determines that the call shall be routed to multiple terminations and returns this information to the Originating MSC in the locreq.

Parameters are as in Section 4.17.1, Step-b, with the exception that MSCID, PC_SSN, and PSTNRoutingInfo are not included and with the following additions:		
Parameters	Usage	Type
MultipleRoutingInfo:	Call routing information:	
[TerminationList]	Multiple termination information.	R
[RoutingDigits]	Special routing instructions. Include if applicable and if not specified within the TerminationList parameter.	O
[Digits(Carrier)]	Called subscriber's PIC for use in inter-MSC call routing. Include if applicable and if not specified within the TerminationList parameter.	O

4.17.6 Unsuccessful LocationRequest: Access Denied without Routing Information Returned

This operation scenario describes the LocationRequest operation when access is denied.

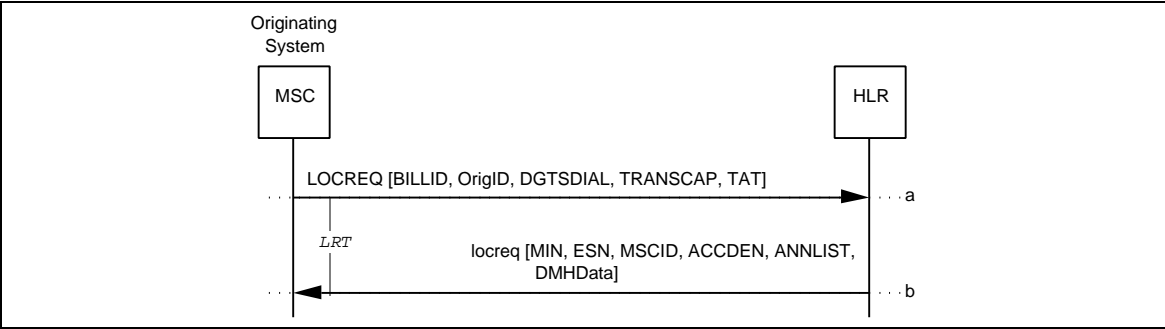

Figure 42 Unsuccessful LocationRequest: Access Denied without Routing Information Returned

1
2
3
4
5
6
7
8
9
10
11
12
13
14
15
16
17
18
19
20
21
22
23
24
25
26
27
28
29
30
31
32
33
34
35
36
37
38
39
40
41
42
43
44
45
46
47
48
49
50
51
52
53
54
55
56
57
58
59
60

- 1
2
3
4
5
6
- a. Same as Section 4.17.1, Step-a.
- b. The HLR determines that access cannot be granted to the MS and returns this indication to the Originating MSC in the `Locreq`.

7
8
9
10
11
12
13
14
15
16
17
18
19
20
21
22
23
24
25
26
27
28
29
30
31
32
33
34
35
36
37
38
39
40
41
42
43
44
45
46
47
48
49
50
51

Parameters	Usage	Type	
MIN ¹	Called MS MIN.	MBC	
ESN ¹	Called MS ESN.	MBC	
MSCID	Originating MSC's MSCID.	R	
ACCDEN	Indicates reason for denying access.	R	
ANLIST	List of tones or announcements to play. If not included, announcement is based on other parameters in response.	O	
DMHData:	Data for <i>DMH</i> recording purposes:		
[DMH_AccountCode-Digits]	Include if applicable.	O	
[DMH_AlternateBilling-Digits]	Include if applicable.	O	
[DMH_BillingDigits]	Include if applicable.	O	
[MobileDirectory-Number]	Include if applicable.	O	
ChargingAreaInformation	Indicates charge area for the called MS.	O	*
CarrierIdentificationCode	Indicates carrier identification code for the called MS.	O	*
MobileAdditionalParty'sCategory3	Indicates information concerning billing system for the called MS.	O	*

52
53
54
55
56
57
58
59
60

¹This parameter may be ignored since its contents may not be meaningful in the context of *IS-41-C*, other than for recording purposes (but is mandatory for backward compatibility reasons).

1
2
3
4 **4.18 MSInactive**

5
6 The MSInactive (MSINACT) operation is used (a) to indicate that an MS is inactive, (b)
7 by the Serving VLR to notify the HLR of the cancellation of an MS's registration, and (c)
8 by the HLR to provide the MS's CallHistoryCount to the AC when the SSD is shared with
9 the VLR, and the VLR cancels the MS's registration.
10

11 The following table lists the valid combinations of invoking and responding FEs.

12 **Table 19 FE Combinations for MSINACT**

	INVOKING FE	RESPONDING FE
Case 1	Serving MSC	Serving VLR
Case 2	Serving VLR	HLR
Case 3	HLR	AC

4.18.1 Successful MSInactive: MS Declared Inactive

This operation scenario describes the use of the MSInactive operation to declare an MS inactive.

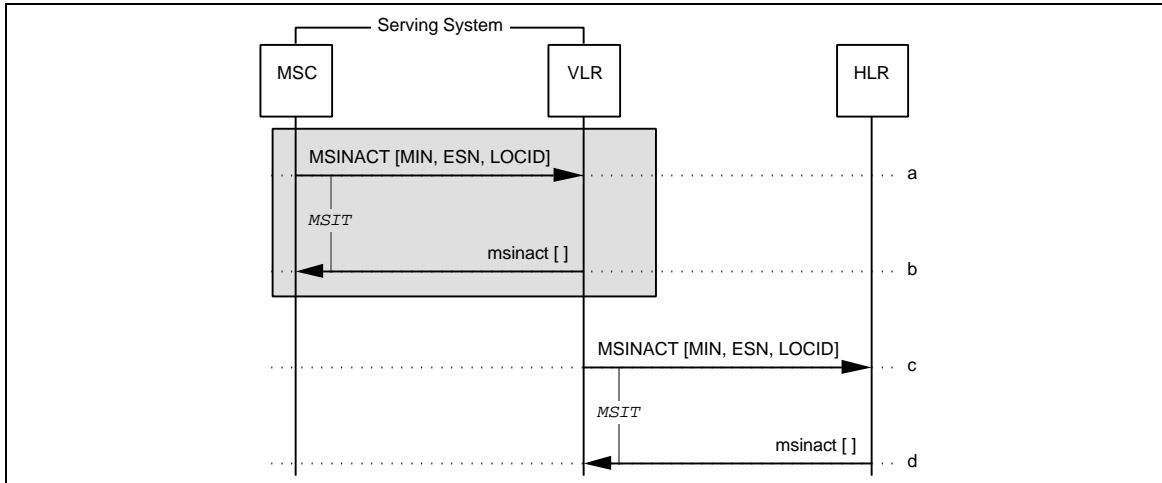

Figure 43 Successful MSInactive: MS Declared Inactive

- a. If the Serving MSC determines that an MS is no longer active, it may report the MS's inactivity by sending an MSI NACT to the Serving VLR.

Parameters	Usage	Type
MIN	Served MS MIN.	R
ESN	Served MS ESN.	R
LOCID	MS's LocationAreaID. Include if available.	O
ChargingAreaInformation	Indicates charge area for the served MS.	O
CarrierIdentificationCode	Indicates carrier identification code for the served MS.	O

*
*
*

- b. The Serving VLR sends an empty msi nact to the Serving MSC.
- c. The Serving VLR determines that an MS is inactive based either on the receipt of an MSI NACT from the Serving MSC or on internal algorithms. It may report the MS's inactivity by sending an MSI NACT to the HLR.
- d. The HLR sends an empty msi nact to the Serving VLR.

4.18.2 Successful MSInactive: MS Deregistered

This operation scenario describes the use of the MSInactive operation to deregister an MS and convey the CallHistoryCount from the VLR, through the HLR to the AC.

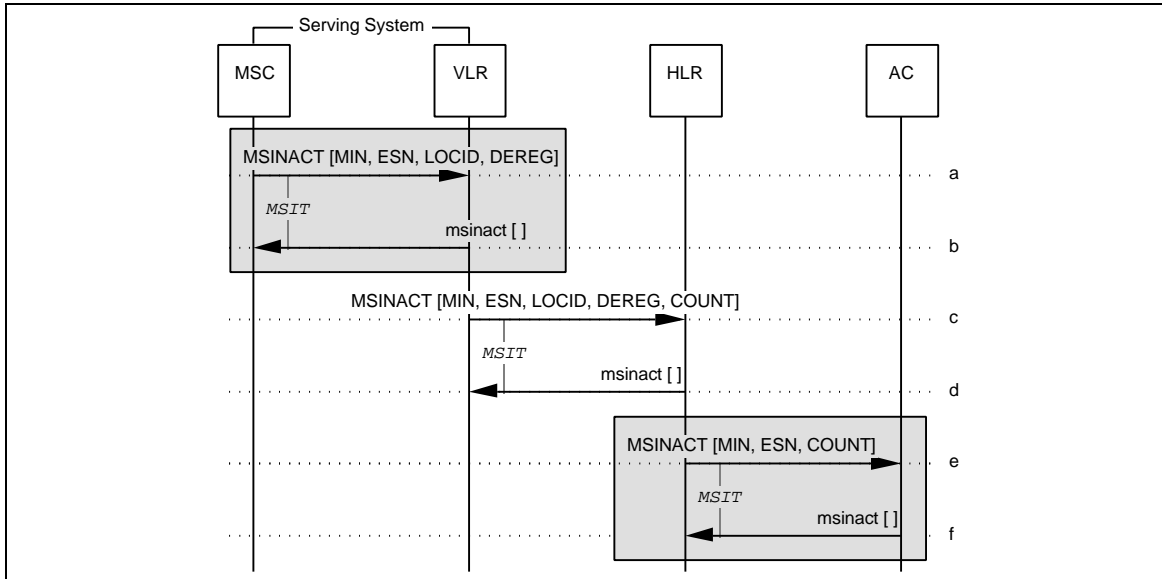

Figure 44 Successful MSInactive: MS Deregistered

- a. The Serving MSC determines that deregistration of a served MS is required. This may be due to receipt of an MS power-down indication, MS inactivity, or loss of radio contact. The Serving MSC sends an MSINACT, including a DeregistrationType parameter, to its VLR. At this point, the MSC may choose to remove all record of the MS from its memory.

Parameters	Usage	Type
MIN	Served MS MIN.	R
ESN	Served MS ESN.	R
LOCID	MS's LocationAreaID. Include if available.	O
DEREG	Indication that MS is to be deregistered.	R
ChargingAreaInformation	Indicates charge area for the served MS.	O
CarrierIdentificationCode	Indicates carrier identification code for the served MS.	O

*
*
*

- b. Same as Section 4.18.1, Step-b.

1
2
3
4
5
6
7
8
9
10
11
12
13
14
15
16
17
18
19
20
21
22
23
24
25
26
27
28
29
30
31
32
33
34
35
36
37
38
39
40
41
42
43
44
45
46
47
48
49
50
51
52
53
54
55
56
57
58
59
60

- c. The Serving VLR determines that deregistration of an MS is required based either on the receipt of an **MSI NACT** from the Serving MSC or on internal algorithms. It sends an **MSI NACT**, including a **DeregistrationType** parameter, to the HLR. At this point, the VLR may choose to remove all record of the MS from its memory.

Parameters are as in Step-a, with the following addition:		
Parameters	Usage	Type
COUNT	CallHistoryCount. Include if MS registration is canceled and if SSD is shared.	O

- d. The HLR sends an empty **msi nact** to the Serving VLR and removes its pointer to the VLR.
- e. If SSD is shared and **CallHistoryCount** was received from the Serving VLR, the HLR sends an **MSI NACT** to the AC.

Parameters	Usage	Type
MIN	Served MS MIN.	R
ESN	Served MS ESN.	R
COUNT	CallHistoryCount received from VLR.	R

- f. The AC sends an empty **msi nact** to the HLR.

4.19 OriginationRequest

The OriginationRequest (ORREQ) operation is used to request call origination treatment on behalf of a registered MS. The following table lists the valid combinations of invoking and responding FEs.

Table 20 FE Combinations for ORREQ

	INVOKING FE	RESPONDING FE
Case 1	Serving MSC	HLR

One of several possible results is returned:

1. Notification that the origination request was successful with routing instructions.
2. Notification that the origination request was unsuccessful with an (optional) indication of the treatment to provide the served MS.

4.19.1 Successful OriginationRequest

This operation scenario describes the OriginationRequest operation when the call origination request is successful.

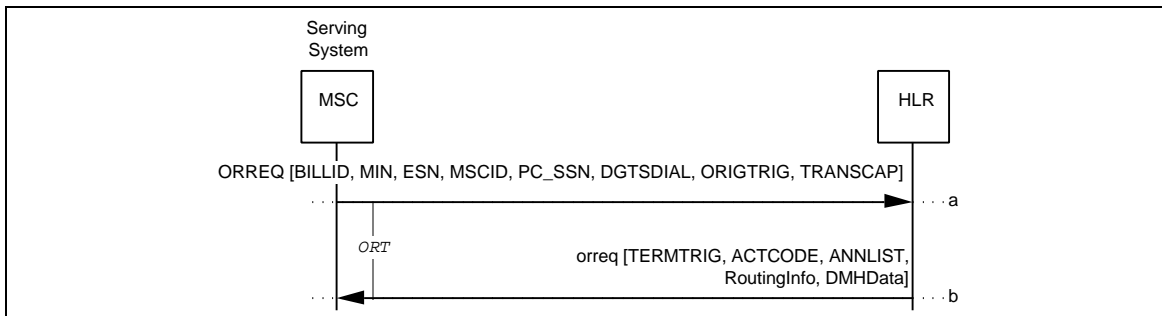

Figure 45 Successful OriginationRequest

1
2
3
4
5
6
7
8
9
10
11
12
13
14
15
16
17
18
19
20
21
22
23
24
25
26
27
28
29
30
31
32
33
34
35
36
37
38
39
40
41
42
43
44
45
46
47
48
49
50
51
52
53
54
55
56
57
58
59
60

- a. Dialed digits are included in an ORREQ and sent by the Serving MSC to the HLR associated with the MS.

1
2
3
4
5
6
7
8
9
10
11
12
13
14
15
16
17
18
19
20
21
22
23
24
25
26
27
28
29
30
31
32
33
34
35
36
37
38
39
40
41
42
43
44
45
46
47
48
49
50
51
52
53
54
55
56
57
58
59
60

Parameters	Usage	Type
BILLID	Call ID. Used for billing and redirection purposes when ORREQ results in call routing.	R
MIN	Served MS MIN.	R
ESN	Served MS ESN.	R
MSCID	Serving MSC MSCID.	R
PC_SSN	Serving MSC PC_SSN. Include if SS7 carriage services are used.	O
DGTSDIAL	Digits, entered by served MS, which identify the called party.	R
ORIGTRIG	Indicates the origination trigger responsible for the operation invocation.	R
TRANSCAP	Indicates the Serving MSC's transaction capabilities at the current time.	R
ChargingAreaInformation	Indicates charge are for the served MS.	O
CarrierIdentificationCode	Indicates carrier identification code for the served MS.	O

*
*
*

- b. The HLR determines that the origination request be approved and returns routing instructions in the *orreq*.

Parameters	Usage	Type
TERMTRIG	Termination trigger points currently active for the MS. Include if applicable.	O
ACTCODE	Include if action to be performed is not implied through presence of other parameters.	O
ANNLIST	List of tones or announcements to play. If not included, announcement is based on other parameters in response.	O
RoutingInfo:	Call routing information:	
[TerminationList]	Call termination information.	R
[RoutingDigits]	Special routing instructions. Include if applicable and if not specified within the TerminationList parameter.	O
[CarrierDigits]	Calling subscriber's PIC. Include if applicable and if not specified within the TerminationList parameter.	O
DMHData:	Data for <i>DMH</i> recording purposes:	
[DMH_AccountCode-Digits]	Include if applicable.	O
[DMH_AlternateBilling-Digits]	Include if applicable.	O
[DMH_BillingDigits]	Include if applicable.	O
[DMH_Redirection-Indicator]	Include if applicable.	R

1
2
3
4
5
6
7
8
9
10
11
12
13
14
15
16
17
18
19
20
21
22
23
24
25
26
27
28
29
30
31
32
33
34
35
36
37
38
39
40
41
42
43
44
45
46
47
48
49
50
51
52
53
54
55
56
57
58
59
60

[MobileDirectory- Number]	Include if applicable.	O
------------------------------	------------------------	---

4.19.2 Unsuccessful OriginationRequest

This operation scenario describes the OriginationRequest operation when the call origination request is unsuccessful.

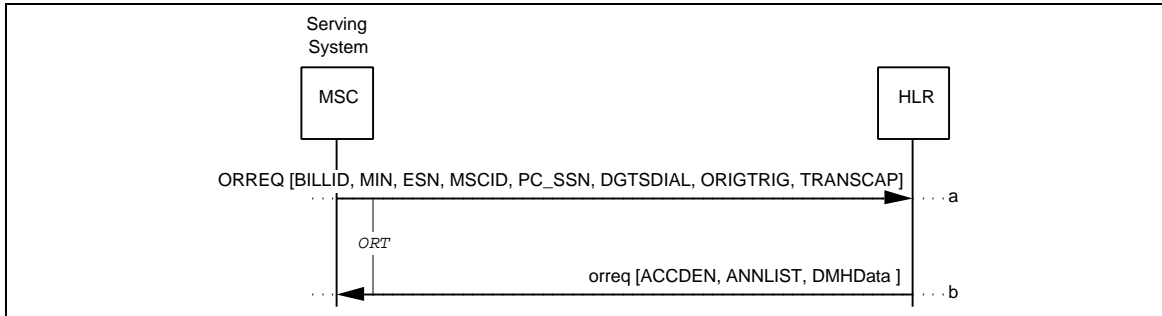

Figure 46 Unsuccessful OriginationRequest

- a. Same as Section 4.19.1, Step-a.
- b. The HLR determines that the origination request be rejected and returns an appropriate indication in the *orreq*.

Parameters	Usage	Type
ACCDEN	Reason for denying access.	R
ANNLIST	List of tones or announcements to play. If not included, announcement is based on other parameters in response.	O
DMHData:	Data for <i>DMH</i> recording purposes:	
[DMH_AccountCode-Digits]	Include if applicable.	O
[DMH_AlternateBilling-Digits]	Include if applicable.	O
[DMH_BillingDigits]	Include if applicable.	O
[MobileDirectory-Number]	Include if applicable.	O

4.20 QualificationDirective

The QualificationDirective (QUALDIR) operation is used to update the authorization information, profile information, or both, previously obtained for an MS.

The following table lists the valid combinations of invoking and responding FEs.

Table 21 FE Combinations for QUALDIR

	INVOKING FE	RESPONDING FE
Case 1	HLR	Serving VLR
Case 2	Serving VLR	Serving MSC

One of several possible results is achieved:

1. The MS is re-authorized with an indication of the authorization duration (e.g., per call, eight hours, one day).
2. Item 1 along with the delivery of the MS's updated calling capabilities (i.e., profile information) to the serving system.
3. An update of the MS's calling capabilities is delivered to the serving system.
4. The MS is de-authorized with reason (e.g., due to a delinquent account).

4.20.1 Successful QualificationDirective: Re-authorization Only

This operation scenario describes the QualificationDirective operation when authorization is re-confirmed with no profile update.

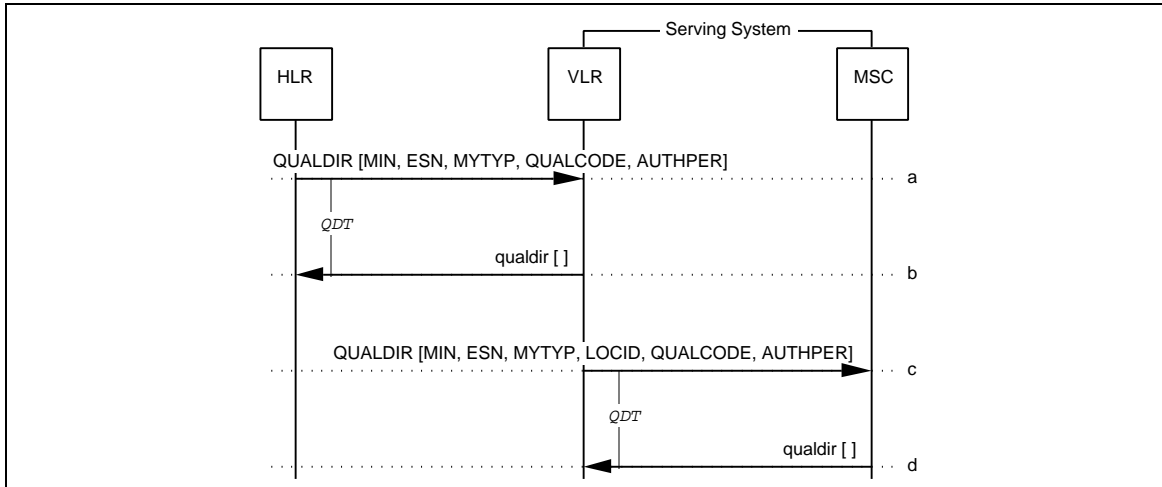

Figure 47 Successful QualificationDirective: Re-authorization Only

- a. The HLR reports the change in the MS's service profile by sending a QUALDIR to the VLR where the MS is registered.

Parameters	Usage	Type
MIN	Served MS MIN.	R
ESN	Served MS ESN.	R
MYTYP	HLR vendor identification.	MBC
QUALCODE	Type of qualification = validation only.	MBC
AUTHPER	Authorization confirmed indication with period of authorization.	R

- b. The VLR sends an empty qualdir to the HLR.
- c. The VLR reports the change in the MS's service profile by sending a QUALDIR to the Serving MSC.

Parameters are as in Step-a, with the following modifications:		
Parameters	Usage	Type
MYTYP	Serving VLR vendor identification.	MBC
LOCID	Location area identity of MS, if available.	O

- d. On receipt of the QUALDIR, the Serving MSC sends an empty qualdir to the VLR.

4.20.2 Successful QualificationDirective: Re-authorization and Update Profile

This operation scenario describes the QualificationDirective operation when authorization is confirmed and the MS's profile is also supplied.

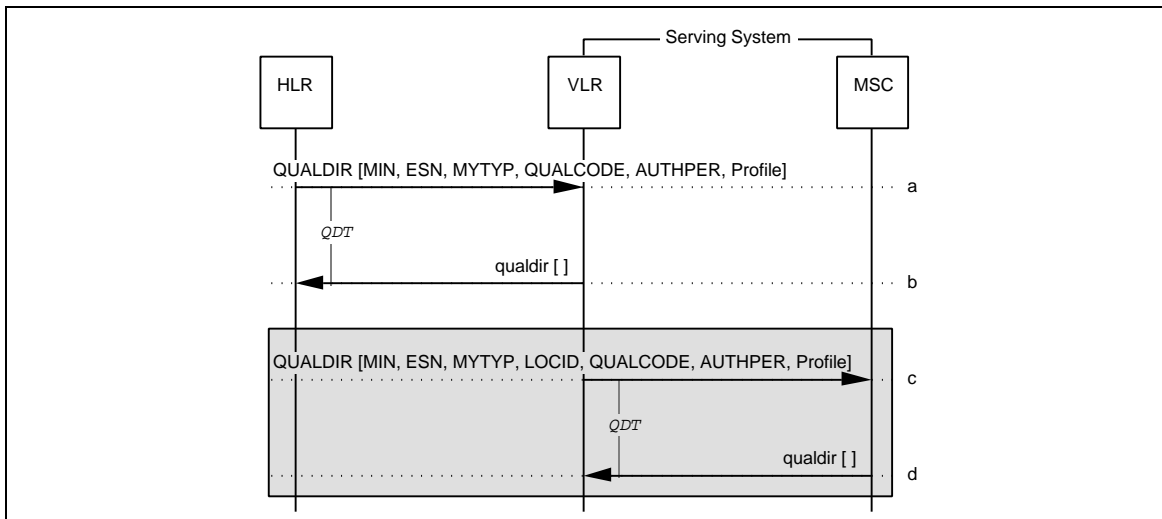

Figure 48 Successful QualificationDirective: Re-authorization and Update Profile

a-d. Same as Section 4.20.1, Steps a-d.

Parameters are as in Section 4.20.1, Steps a-d, with the following modifications to both Steps a and c:		
Parameters	Usage	Type
QUALCODE	Type of qualification = validation and profile.	MBC
Profile:	Subscriber's profile information:	
[CallingFeaturesIndicator]	Authorization and activity states for features.	O
[OriginationIndicator]	Type of calls MS is allowed to originate.	O
[Digits(Restriction)]	Selected NDC-X1 ~ Xn allowed for call origination as indicated in riginationIndicator. Include if applicable.	O
[Termination-RestrictionCode]	Type of calls MS is allowed to terminate.	O

continued on next page...

1
2
3 ...continued from previous page
4

Parameters	Usage	Type
[Digits(Carrier)]	Indicates MS's preferred IC, if applicable.	O
[RoutingDigits]	Special routing instructions, if applicable.	O
[Geographic-Authorization]	Include if applicable.	O
[Authentication-Capability]	Include if MS is required to do authentication.	O
[DMH_AccountCode-Digits]	Include if applicable.	O
[DMH_AlternateBilling-Digits]	Include if applicable.	O
[DMH_BillingDigits]	Include if applicable.	O
[MobileDirectory-Number]	Include if applicable.	O
[MessageWaiting-NotificationCount]	Include if MessageWaitingNotificationType is <i>Count Indication</i> .	O
[MessageWaiting-NotificationType]	Include if Message Waiting Notification feature is active and an action is required.	O
[OriginationTriggers]	Origination trigger points currently active for the subscriber. Include if applicable.	O
[PACAIndicator]	Indicates the PACA permanent activation status and priority level assigned to the subscriber, if applicable.	O
[PreferredLanguage-Indicator]	Indicates the preferred language associated with the subscriber, if applicable.	O
[SMS_Origination-Restrictions]	Defines the type of messages the MS is allowed to originate, if applicable.	O
[SMS_Termination-Restrictions]	Defines the type of messages the MS is allowed to terminate, if applicable.	O
[SPINIPIN]	Indicates Subscriber's PIN, if applicable.	O
[SPINITriggers]	SPINI trigger points currently active for the subscriber. Include if applicable.	O
[TerminationTriggers]	Termination trigger points currently active for the subscriber. Include if applicable.	O
[MobileAdditionalParty's Category3]	Indicates information concerning billing system for the served MS.	O

*
*

50 Note: Steps c and d are optional and are executed only if the service or call
51 progress may be discontinued.
52
53
54
55
56
57
58
59
60

4.20.3 Successful QualificationDirective: Update Profile Only

This operation scenario describes the QualificationDirective operation when the request is to update the MS's profile only.

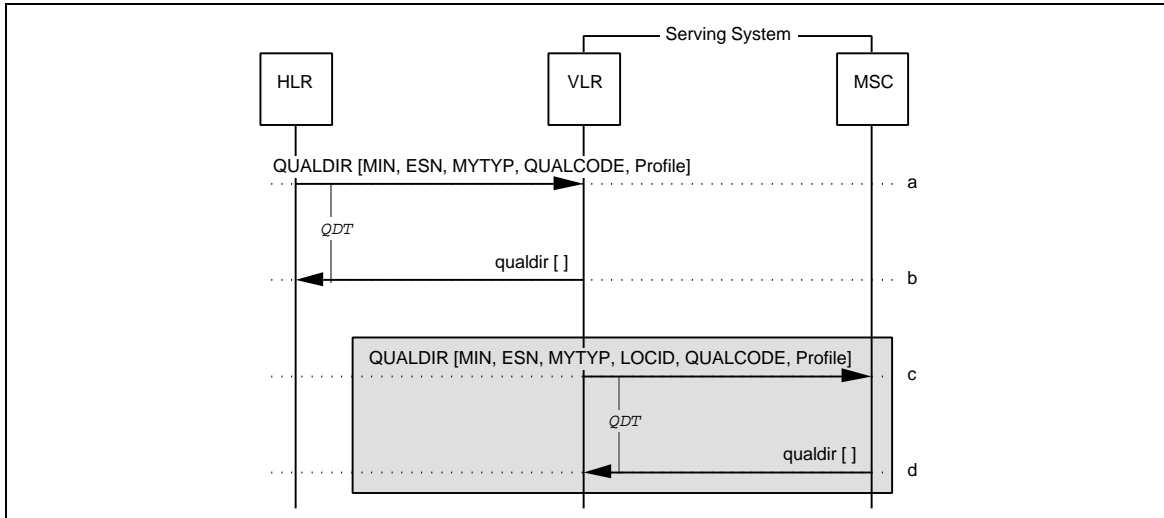

Figure 49 Successful QualificationDirective: Update Profile Only

a-d. Same as Section 4.20.2, Steps a-d.

Parameters are as in Section 4.20.2, Steps a-d, with the AUTHPER parameter omitted in Steps a and c, and with the following modification to both Steps a and c:		
Parameters	Usage	Type
QUALCODE	Type of qualification = profile only.	MBC

Note: Steps c and d are optional and are executed only if the service or call in progress may be discontinued.

4.20.4 Successful QualificationDirective: De-authorization

This operation scenario describes the QualificationDirective operation when used to de-authorize the MS.

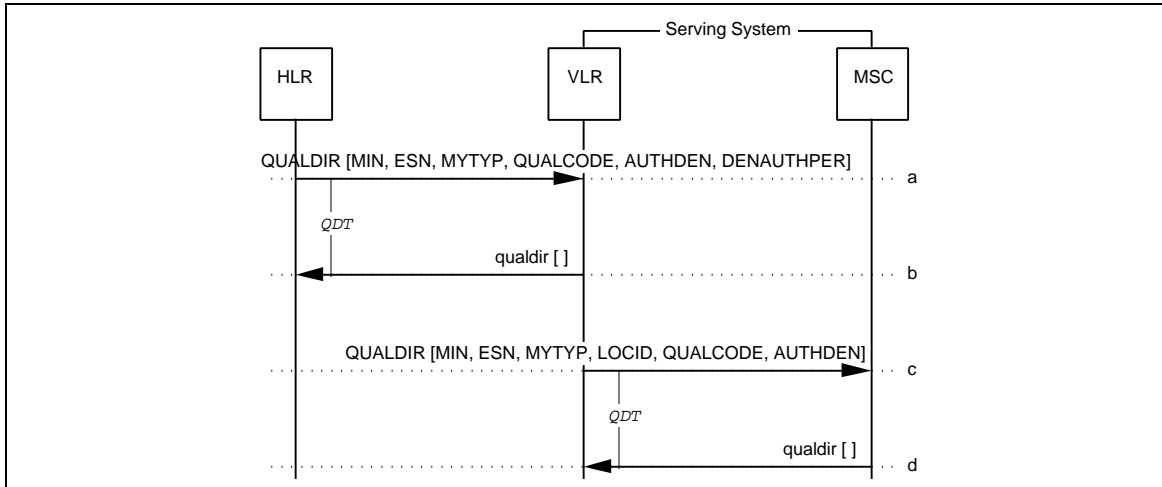

Figure 50 Successful QualificationDirective: De-authorization

- a. The HLR reports the change in the MS's service profile by sending a QUALDIR to the VLR where the MS is registered.

Parameters	Usage	Type
MIN	Served MS MIN.	R
ESN	Served MS ESN.	R
MYTYP	HLR vendor identification.	MBC
QUALCODE	Type of qualification = validation only.	MBC
AUTHDEN	Authorization denied indication with reason.	R
DENAUTHPER	Indicates the duration of time the VLR should retain a record and suppress re-registrations for the authorization denied MS.	O

1
2
3
4
5
6
7
8
9
10
11
12
13
14
15
16
17
18
19
20
21
22
23
24
25
26
27
28
29
30
31
32
33
34
35
36
37
38
39
40
41
42
43
44
45
46
47
48
49
50
51
52
53
54
55
56
57
58
59
60

- b. The VLR sends an empty **qual di r** to the HLR.
- c. The VLR reports the change in the MS's service profile by sending a **QUALDI R** to the Serving MSC.

Parameters are as in Step-a, with the following modification:		
Parameters	Usage	Type
MIN	Served MS MIN.	R
ESN	Served MS ESN.	R
MYTYP	Serving VLR vendor identification.	MBC
QUALCODE	Type of qualification = validation only.	MBC
AUTHDEN	Authorization denied indication with reason.	R
LOCID	Location area identity of MS, if available.	O

- d. On receipt of the **QUALDI R**, the Serving MSC may discontinue any call or service in progress, and sends an empty **qual di r** to the VLR.

4.21 QualificationRequest

The QualificationRequest (QUALREQ) operation is used (a) to request validation of an MS or (b) to request validation of an MS and obtain its profile information.

The following table lists the valid combinations of invoking and responding FEs.

Table 22 FE Combinations for QUALREQ

	INVOKING FE	RESPONDING FE
Case 1	Serving MSC	Serving VLR
Case 2	Serving VLR	HLR

One of several possible results is returned:

1. An indication that authorization is confirmed with an indication of the authorization duration (e.g., per call, eight hours, one day).
2. Item 1 along with the MS's calling capabilities (i.e., profile information).
3. Only the MS's calling capabilities.
4. An indication that authorization is denied with reason for denial (e.g., due to an invalid serial number).

4.21.1 Successful QualificationRequest: Authorization Confirmed

This operation scenario describes the QualificationRequest operation when authorization is confirmed and no profile is requested.

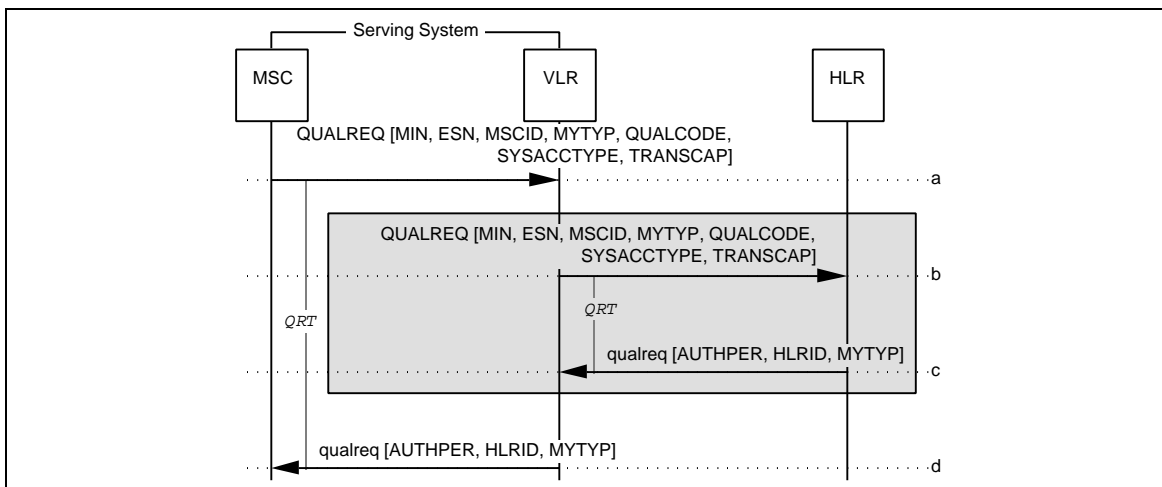

Figure 51 Successful QualificationRequest: Authorization Confirmed

- 1
2
3
4
5
6
7
8
- a. After determining that a roaming MS is now within its service area, the Serving MSC sends a **QUALREQ** to its VLR; the Serving MSC may detect the MS's presence through autonomous registration, call origination, call termination (i.e. a page response following a call to the roamer port) or a service order.

Parameters	Usage	Type
MIN	Served MS MIN.	R
ESN	Served MS ESN.	R
MSCID	Serving MSC MSCID.	R
MYTYP	Serving MSC vendor identification.	MBC
QUALCODE	Type of request = validation only.	R
SYSACCTYPE	Indicates the type of system access.	R
TRANSCAP	Indicates the serving system's transaction capability at the current time.	R

- 9
10
11
12
13
14
15
16
17
18
19
20
21
22
23
24
25
26
- b. If the MS had previously registered with an MSC within the domain of the VLR, the VLR may take no further action other than to record the identity of the MSC currently serving the MS and proceed to Step-d. If the MS is unknown to the VLR or if the information requested by the MSC is not available at the VLR, the VLR sends a **QUALREQ** to the HLR associated with the MS.

Parameters are as in Step-a, with the following modifications:		
Parameters	Usage	Type
MYTYP	VLR vendor identification.	MBC

- 27
28
29
30
31
32
33
- c. The HLR determines that authorization can be granted to the MS and returns this indication to the Serving VLR in the **qual req**.

Parameters	Usage	Type
AUTHPER	Authorization confirmed indication with period of authorization.	R
HLRID [MSCID]	HLR MSCID to key MS record against for a subsequent UnreliableRoamerDataDirective.	R
MYTYP	HLR vendor identification.	MBC

- 34
35
36
37
38
39
40
41
42
43
- d. The VLR sends a **qual req** to the Serving MSC.

Parameters are as in Step-c, with the following modification:		
Parameters	Usage	Type
HLRID [MSCID]	HLR MSCID. Include if received in Step-c.	O
MYTYP	VLR vendor identification.	MBC

1
2
3
4 **4.21.2 Successful QualificationRequest: Authorization Confirmed and Profile Returned**
5
6

7 This operation scenario describes the QualificationRequest operation when authorization is
8 confirmed and the MS's profile is also requested.
9

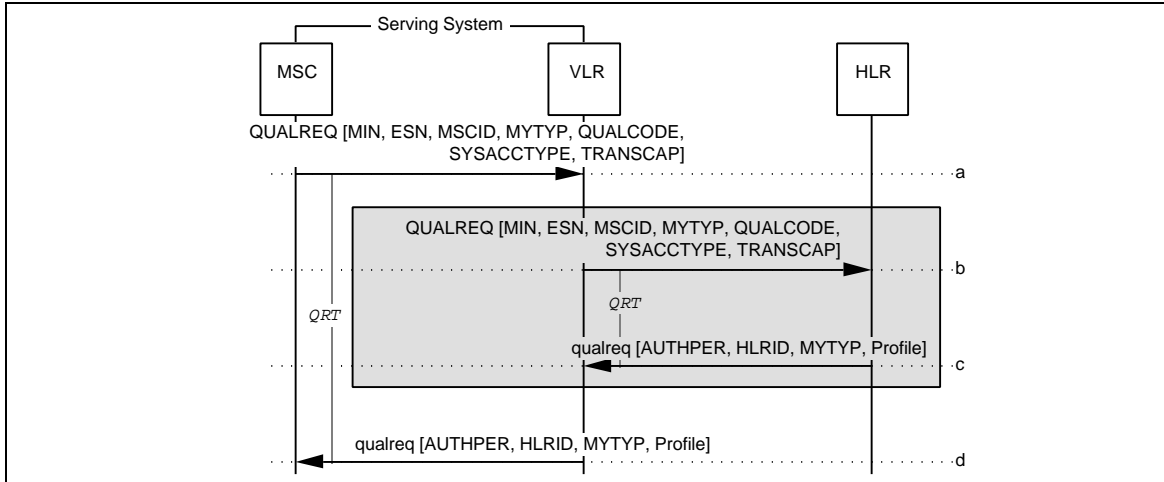

10
11
12
13
14
15
16
17
18
19
20
21
22
23
24
25
26
27 **Figure 52 Successful QualificationRequest:**
28 **Authorization Confirmed and Profile Returned**

29 a-b. Same as Section 4.21.1, Steps a-b.

30
31
32 Parameters are as in Section 4.21.1, Steps a-b, with the following modification to both
33 Steps a and b:

Parameters	Usage	Type
QUALCODE	Type of request = validation and profile.	R

34
35
36
37
38
39
40
41
42
43
44
45
46
47
48
49
50
51
52
53
54
55
56
57
58
59
60

- c. The HLR determines that authorization can be granted to the MS and returns this indication, as well as the MS's profile, to the Serving VLR in the **qual req.**

Parameters are as in Section 4.21.1, Step-c, with the following addition:		
Parameters	Usage	Type
Profile:	Subscriber's profile information:	
[CallingFeaturesIndicator]	Authorization and activity states for features.	R
[OriginationIndicator]	Type of calls MS is allowed to originate.	R
[Digits(Restriction)]	Selected leading digits or full Directory Number allowed for call origination as indicated in OriginationIndicator. Include if applicable.	O
[Termination- RestrictionCode]	Type of calls MS is allowed to terminate.	R
[Digits(Carrier)]	Indicates MS's preferred IC, if applicable.	O
[RoutingDigits]	Special routing instructions, if applicable.	O
[Geographic- Authorization]	Include if applicable.	O
[Authentication- Capability]	Include if authentication of MS is required.	O
[DMH_AccountCode- Digits]	Include if applicable.	O
[DMH_AlternateBilling- Digits]	Include if applicable.	O
[DMH_BillingDigits]	Include if applicable.	O
[MobileDirectory- Number]	Include if applicable.	O
[MessageWaiting- NotificationCount]	Include if MessageWaitingNotificationType is <i>Count Indication</i> .	O
[MessageWaiting- NotificationType]	Include if Message Waiting Notification feature is active and an action is required.	O
[OriginationTriggers]	Origination trigger points currently active for the subscriber. Include if applicable.	O
[PACAIndicator]	Indicates the PACA permanent activation status and priority level assigned to the subscriber, if applicable.	O
[PreferredLanguage- Indicator]	Indicates the preferred language associated with the subscriber, if applicable.	O
[SMS_Origination- Restrictions]	Defines the type of messages the MS is allowed to originate, if applicable.	O
[SMS_Termination- Restrictions]	Defines the type of messages the MS is allowed to terminate, if applicable.	O
[SPINIPIN]	Indicates Subscriber's PIN, if applicable.	O
[SPINITriggers]	SPINI trigger points currently active for the	O

1
2
3
4
5
6
7
8
9
10
11
12
13
14
15
16
17
18
19
20
21
22
23
24
25
26
27
28
29
30
31
32
33
34
35
36
37
38
39
40
41
42
43
44
45
46
47
48
49
50
51
52
53
54
55
56
57
58
59
60

	subscriber. Include if applicable.		
[TerminationTriggers]	Termination trigger points currently active for the subscriber. Include if applicable.	O	
[ChargingAreaInformation]	Indicate charge area for the served MS.	O	*
[CarrierIdentificationCode]	Indicates carrier identification code for the served MS.	O	*
[MobileAdditionalParty's Category3]	Indicates information concerning billing system for the served MS.	O	*

1
2
3
4
5
6
7
8
9
10
11
12
13
14
15
16
17
18
19
20
21
22
23
24
25
26
27
28
29
30
31
32
33
34
35
36
37
38
39
40
41
42
43
44
45
46
47
48
49
50
51
52
53
54
55
56
57
58
59
60

d. The VLR sends a **qual req** to the Serving MSC.

Parameters are as in Step-c, with the following modification:		
Parameters	Usage	Type
HLRID [MSCID]	HLR MSCID. Include if received in Step-c.	O
MYTYP	VLR vendor identification.	MBC

4.21.3 Successful QualificationRequest: Profile Returned Only

This operation scenario describes the QualificationRequest operation when the request is to retrieve the MS's profile only.

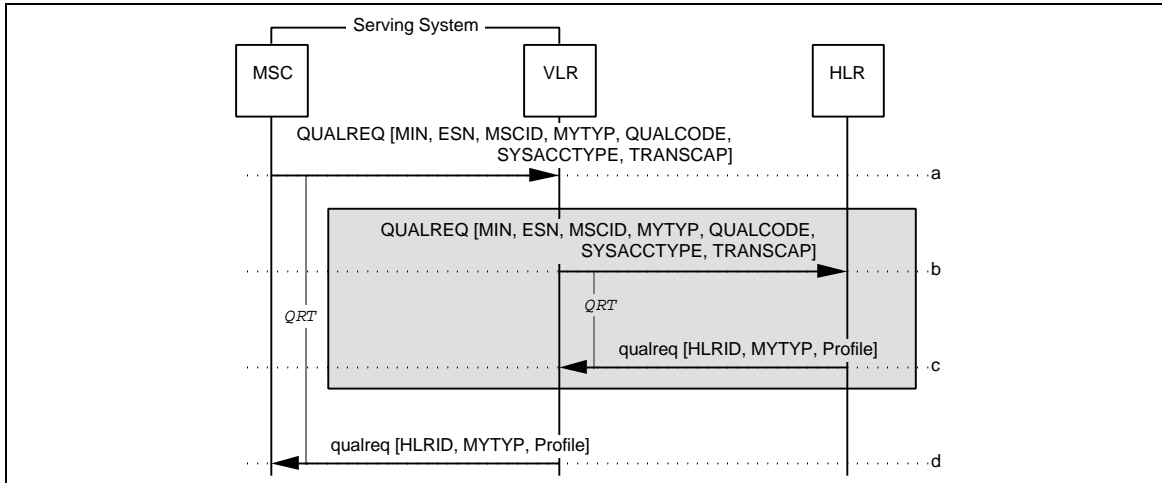

Figure 53 Successful QualificationRequest: Profile Returned Only

a-b. Same as Section 4.21.1, Steps a-b.

Parameters are as in Section 4.21.1, Steps a-b, with the following modification to both Steps a and b:		
Parameters	Usage	Type
QUALCODE	Type of request = profile only.	R

c. The HLR retrieves the MS's profile and returns it to the Serving VLR in the **qual req**. Parameters are as in Section 4.22.2, Step-c, with the deletion of the AUTHPER parameter.

d. The VLR sends a **qual req** to the Serving MSC.

Parameters are as in Step-c, with the following modification:		
Parameters	Usage	Type
HLRID [MSCID]	HLR MSCID. Include if received in Step-c.	O
MYTYP	VLR vendor identification.	MBC

4.21.4 Unsuccessful QualificationRequest: Authorization Denied

This operation scenario describes the QualificationRequest operation when authorization is denied.

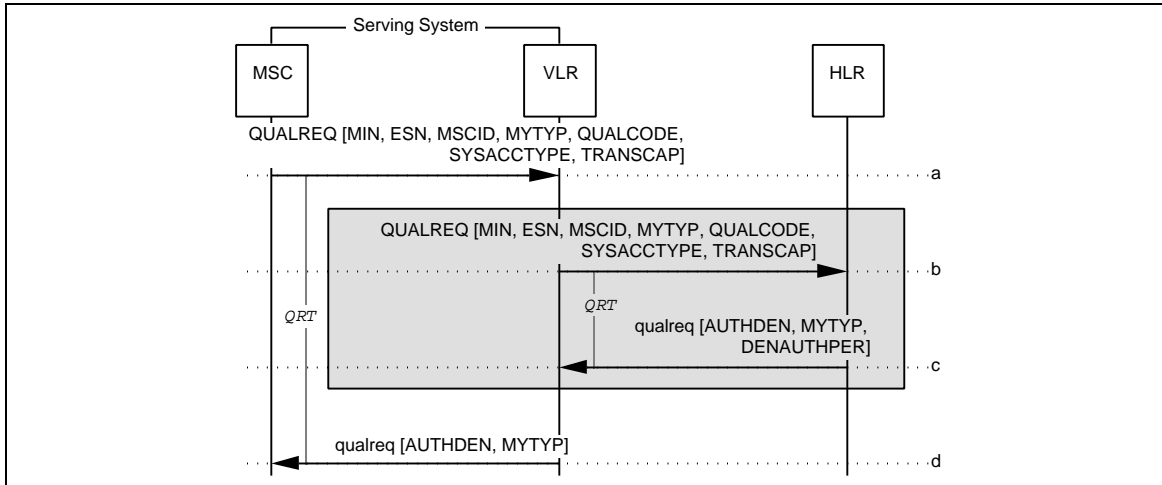

Figure 54 Unsuccessful QualificationRequest: Authorization Denied

a-b. Same as Section 4.21.1, Steps a-b.

Parameters are as in Section 4.22.1, Steps a-b, with the following modification to both Steps a and b:		
Parameters	Usage	Type
QUALCODE	Type of request.	R

c. The HLR determines that authorization cannot be granted to the MS and returns this indication to the Serving VLR in the **qual req**.

Parameters	Usage	Type
AUTHDEN	Authorization denied indication with reason.	R
MYTYP	HLR vendor identification.	MBC
DENAUTHPER	Indicates the duration of time that the VLR should retain a record and suppress re-registrations for the authorization denied MS.	O

d. The VLR sends a **qual req** to the Serving MSC.

Parameters are as in Step-c, with the following modifications:		
Parameters	Usage	Type
MYTYP	VLR vendor identification.	MBC

4.22 RandomVariableRequest

The RandomVariableRequest (RANDREQ) operation is used to request the value of the RandomVariable (RAND) that corresponds to the RANDC received from the MS. This operation may be used if the value of RANDC received from the MS corresponds to a RAND value that may have been transmitted by a Border MSC.

The following table lists the valid combinations of invoking and responding FEs.

Table 23 FE Combinations for RANDREQ

	INVOKING FE	RESPONDING FE
Case 1	Serving MSC	Border MSC

One of several possible results is returned:

1. Notification that the request was successful with the valid RAND value returned.
2. Notification that the request was unsuccessful with no RAND value returned.

4.22.1 Successful RandomVariableRequest

This operation scenario describes a RandomVariableRequest operation when the Border MSC determines the value of RAND used by the MS.

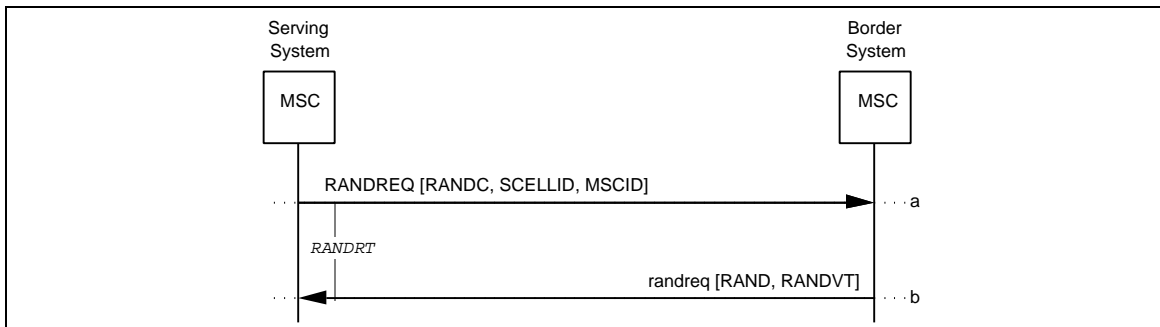

Figure 55 Successful RandomVariableRequest

- a. The Serving MSC determines that the RANDC supplied by the MS does not correspond to a RAND transmitted by the Serving MSC, but may correspond to a RAND used by the Border System.

The Serving MSC includes the RANDC received from the MS and sends a RANDREQ to the Border MSC.

Parameters	Usage	Type
RANDC	Received RANDC value.	R
SCELLID	ID of the serving cell that received the MS access.	R
MSCID	Serving MSC's MSCID.	R

- b. The Border System verifies that the RANDC received from the MS is valid. The Border MSC includes the value of RAND in the randreq.

Parameters	Usage	Type
RAND	Random Variable associated with the RANDC.	R
RANDVT	Time in seconds for which the RAND-RANDC association will remain valid.	R

4.22.2 Unsuccessful RandomVariableRequest

This operation scenario describes a RAND Request operation when the Border MSC cannot determine the value of RAND used by the MS.

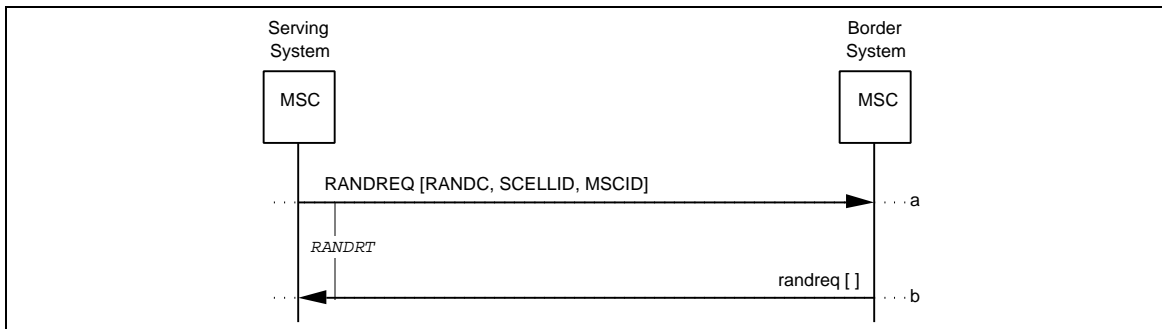

Figure 56 Unsuccessful RandomVariableRequest

- a. Same as Section 4.22.1, Step-a.
- b. The Border System cannot determine the value of RAND used by the MS for this system access and sends an empty randreq to the Serving MSC.

4.23 RedirectionDirective

The RedirectionDirective (REDDIR) operation is used by an Adjunct MSC to direct the Originating MSC to redirect the call after the call is in the conversation state. The Adjunct MSC can respond to the caller, request voice or DTMF tone responses, and can select routing of the call to another destination.

The following table lists the valid combinations of invoking and responding FEs.

Table 24 FE Combinations for REDDIR

	INVOKING FE	RESPONDING FE
Case 1	Adjunct MSC	Originating MSC

There are several possible responses:

1. An empty response indicates a successful request: The Adjunct MSC should expect subsequent action by the Originating MSC.
2. An operation error response indicates an unsuccessful request: The Adjunct MSC should take alternative action.

1
2
3 **4.23.1 Successful Request**
4

5 This operation scenario describes a successful RedirectionDirective operation.

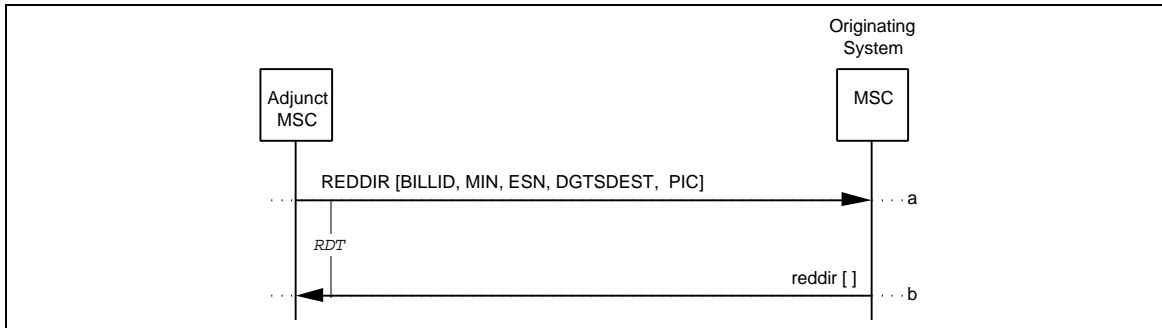

18 **Figure 57 Successful request**

- 19
20
21 a. The Adjunct MSC sends a REDDI R to the Originating MSC, indicating the destination
22 number and if applicable, the inter-exchange carrier to be used.

23

Parameters	Usage	Type
BILLID	Call ID to reference the specific call.	R
MIN	Served MS MIN.	R
ESN	Served MS ESN.	R
DGTSDEST	Forward-to destination number	R
PIC	PIC, if applicable, for this call	O

- 24
25
26
27
28
29
30
31
32
33 b. The Originating MSC determines that it is able to redirect the call and returns this
34 indication to the Adjunct MSC via an empty reddi r.
35
36
37

38 **4.23.2 Unsuccessful Request**
39

40 This operation scenario describes an unsuccessful RedirectionDirective operation.

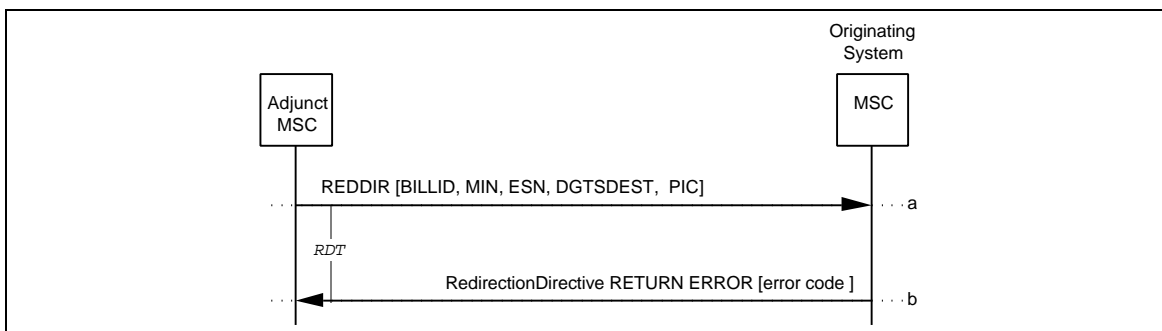

53 **Figure 58 Unsuccessful request**

- 54
55
56 a. Same as Section 4.23.1, Step-a.
57
58
59
60

1
2
3
4
5
6
7
8
9
10
11
12
13
14
15
16
17
18
19
20
21
22
23
24
25
26
27
28
29
30
31
32
33
34
35
36
37
38
39
40
41
42
43
44
45
46
47
48
49
50
51
52
53
54
55
56
57
58
59
60

- b. The Originating MSC determines that it is unable to redirect the call and returns this indication to the Adjunct MSC via a RedirectionDirective RETURN ERROR component with an appropriate error code.

4.24 RedirectionRequest

The RedirectionRequest (REDREQ) operation is used by the Serving MSC to request redirection of a call by the Originating MSC.

The following table lists the valid combinations of invoking and responding FEs.

Table 25 FE Combinations for REDREQ

	INVOKING FE	RESPONDING FE
Case 1	Serving MSC	Originating MSC

There are several possible responses:

1. A empty response indicates a successful request: The Serving MSC should expect subsequent action by the Originating MSC.
2. An operation error response indicates an unsuccessful request: The Serving MSC should take alternative action.

1
2
3 **4.24.1 Successful RedirectionRequest**
4

5 This operation scenario describes a successful RedirectionRequest operation.
6

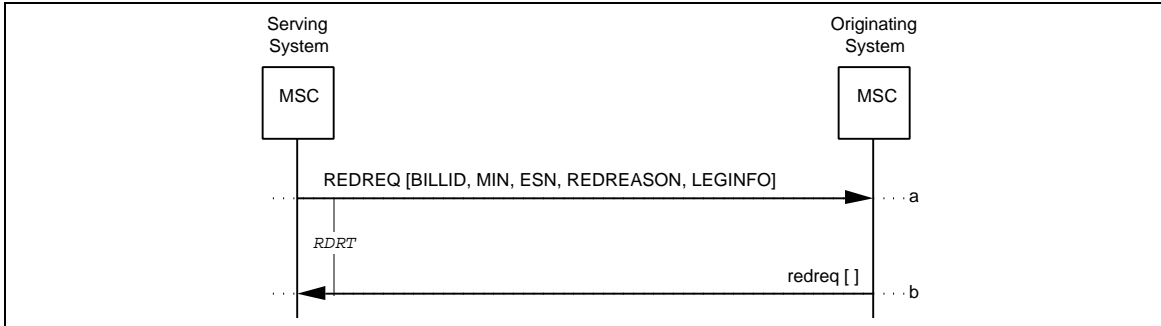

7
8
9
10
11
12
13
14
15
16
17
18 **Figure 59 Successful RedirectionRequest**
19

- 20
21 a. The Serving MSC sends a REDREQ to the Originating MSC, indicating the feature
22 responsible for redirecting the call (e.g., CFB).
23

Parameters	Usage	Type
BILLID	Call ID to reference BillingID of the Originating MSC.	R
MIN	Served MS MIN.	R
ESN	Served MS ESN.	R
REDREASON	Identifies reason for the redirection request.	R
LEGINFO	Identifies a leg in a multiple termination call. Include if available.	O
ChargingAreaInformation	Indicates charge area for the served MS.	O
CarrierIdentificationCode	Indicates carrier identification code for the served MS.	O

- 24
25
26
27
28
29
30
31
32
33
34
35
36
37
38
39 b. The Originating MSC determines that it is able to redirect the call and returns this
40 indication to the Serving MSC via an empty redreq.
41
42
43
44
45
46
47
48
49
50
51
52
53
54
55
56
57
58
59
60

*
*
*

4.24.2 Unsuccessful RedirectionRequest

This operation scenario describes an unsuccessful RedirectionRequest operation.

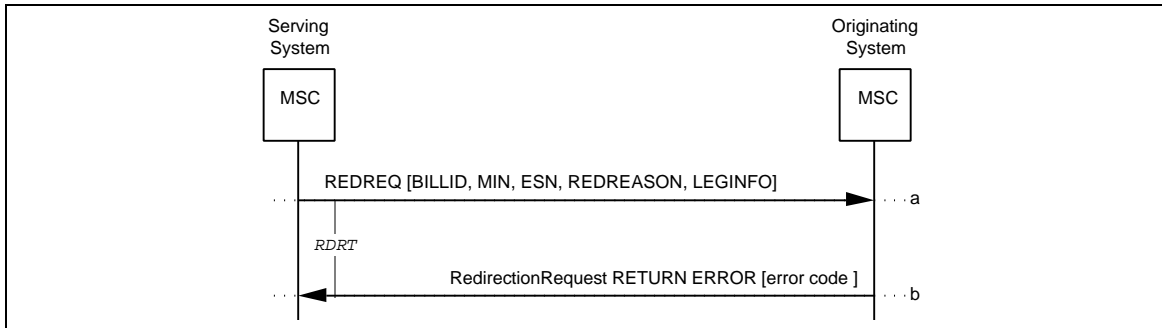

Figure 60 Unsuccessful RedirectionRequest

- a. Same as Section 4.24.1, Step-a.
- b. The Originating MSC determines that it is unable to redirect the call and returns this indication to the Serving MSC via a RedirectionRequest RETURN ERROR component with an appropriate error code.

1
2
3
4
5
6
7
8
9
10
11
12
13
14
15
16
17
18
19
20
21
22
23
24
25
26
27
28
29
30
31
32
33
34
35
36
37
38
39
40
41
42
43
44
45
46
47
48
49
50
51
52
53
54
55
56
57
58
59
60

4.25 RegistrationCancellation

The RegistrationCancellation (REGCANC) operation is used to report, to the responding FE, that a previously registered MS is no longer in its serving area.

The following table lists the valid combinations of invoking and responding FEs.

Table 26 FE Combinations for REGCANC

	INVOKING FE	RESPONDING FE
Case 1	HLR	prior Serving VLR
Case 2	prior Serving VLR	prior Serving MSC

4.25.1 Successful Registration Cancellation: Single Access

This operation scenario describes a successful Registration Cancellation operation under non-multiple access conditions.

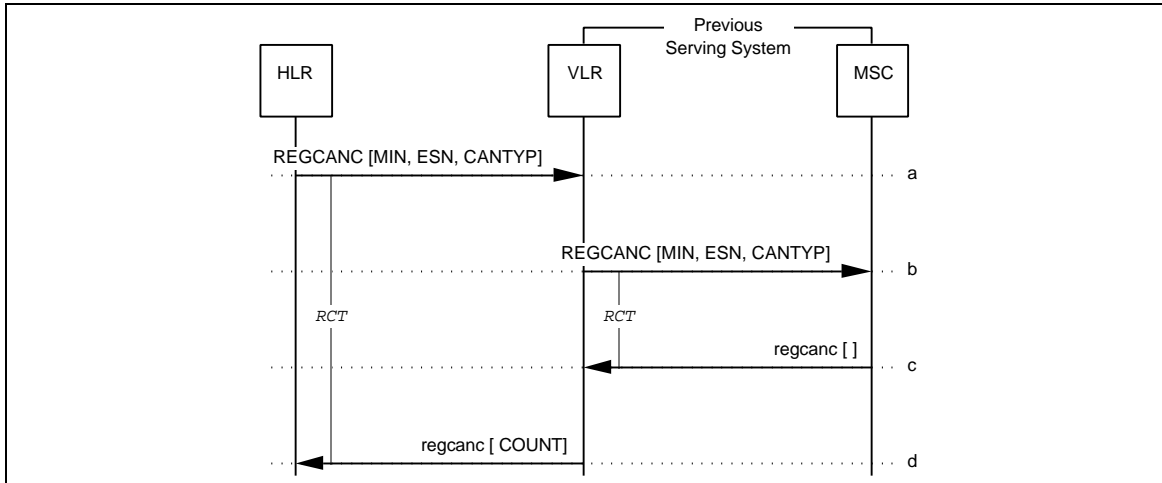

Figure 61 Successful Registration Cancellation: Single Access

- a. After determining that a roaming MS has left the service area in which it had been registered, the HLR sends a REGCANC to the previous Serving VLR. The VLR, upon receipt of the cancellation message, essentially removes all record of the MS from its memory.

Parameters	Usage	Type
MIN	Served MS MIN.	R
ESN	Served MS ESN.	R
CANTYP	Indicates the handling of a call or service interruption caused by the receipt of the REGCANC. Include if applicable.	O

- b. The VLR sends a REGCANC to the previous Serving MSC. The MSC, upon receipt of the cancellation message, may discontinue in progress calls or services for the identified MS and essentially removes all record of the MS from its memory. Parameters are as in Step-a.
- c. The previous Serving MSC acknowledges receipt of the REGCANC by sending an empty regcanc to the previous Serving VLR.
- d. The previous Serving VLR acknowledges receipt of the REGCANC by sending a regcanc to the HLR. The VLR includes the CallHistoryCount parameter if SSD is shared.

Parameters	Usage	Type
COUNT	CallHistoryCount. Include if SSD is shared.	O

4.25.2 Successful RegistrationCancellation: Multiple Access

This operation scenario describes the use of the RegistrationCancellation operation under multiple access conditions. The result is cancellation acceptance by the previous serving system.

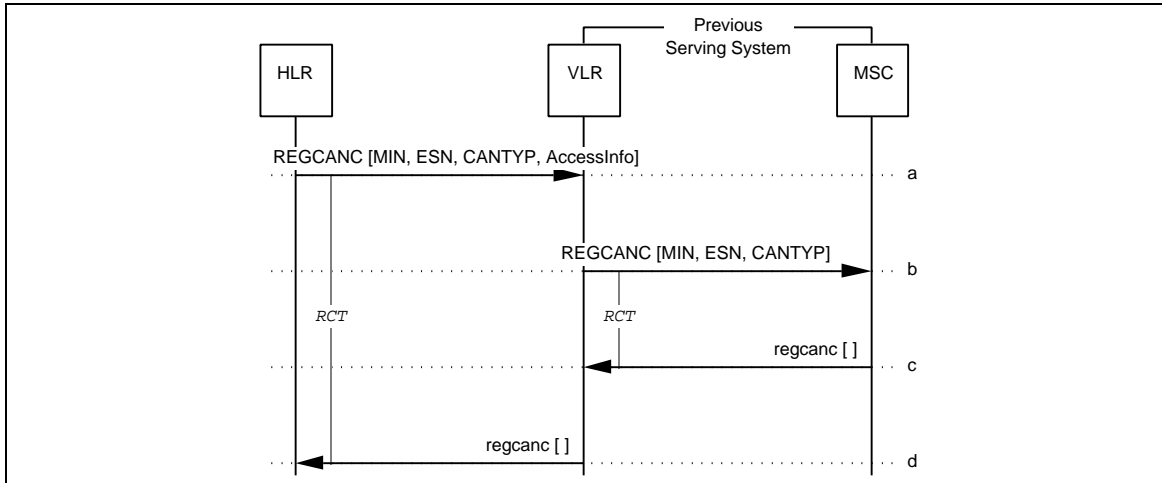

Figure 62 Successful RegistrationCancellation: Multiple Access

- a. After determining that multiple access has occurred, the HLR sends a REGCANC to the previous Serving VLR. Same as Section 4.25.1, Step-a.

Parameters are as in Section 4.25.1, Step-a, with the following additions:		
Parameters	Usage	Type
AccessInfo:	Access information of MS chosen most desirable by HLR:	
[ReceivedSignalQuality]	Raw received signal strength from MS for use in signal strength arbitration.	R
[ControlChannelData]	Includes: DCC and CHNO of analog access channel for use in multiple access detection; CMAC for use in signal strength arbitration.	R
[SystemAccessData]	Indicates the Serving MSC and cell site for use in multiple access detection.	R

- b. The VLR determines that it did not receive an access that matches the registration event identified in the REGCANC, therefore, it sends a REGCANC to the previous Serving MSC. Parameters are as in Section 4.26.1, Step-b.
- c. The previous Serving MSC, upon receipt of the cancellation message, essentially removes all record of the mobile from its memory and acknowledges receipt of the REGCANC by sending an empty regcanc to the previous Serving VLR.
- d. The previous Serving VLR acknowledges receipt of the REGCANC by sending an empty regcanc to the HLR.

4.25.3 Unsuccessful RegistrationCancellation: Multiple Access

This operation scenario describes the use of the RegistrationCancellation operation under multiple access conditions. The result is cancellation rejection by the serving system.

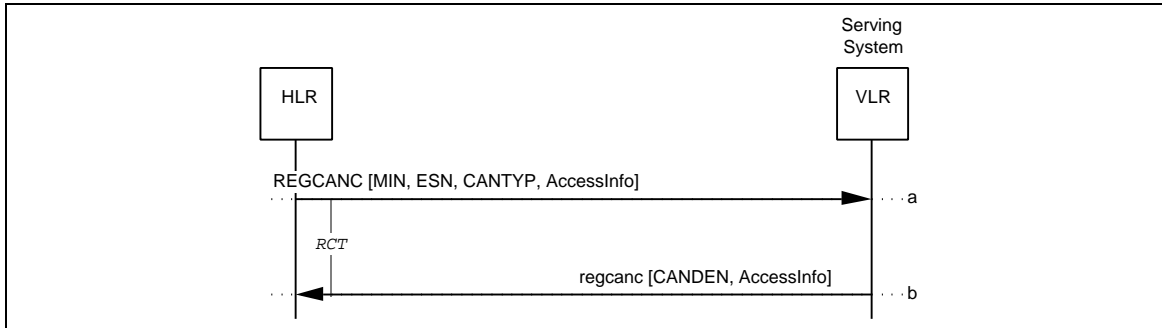

Figure 63 Unsuccessful RegistrationCancellation: Multiple Access

- a. Same as Section 4.25.2, Step-a.
- b. The VLR determines that it did receive an access that matches the registration event identified in the REGCANC; therefore, it performs signal strength arbitration. It determines that it received the best MS signal strength (in the previous REGNOT); therefore, it sends a regcanc with an indication that it denies the cancellation request, by including the CancellationDenied parameter along with the local access information, to the HLR.

Parameters	Usage	Type
CANDEN	Indication that cancellation is denied with reason, where reason = multiple access.	R
AccessInfo:	Access information of MS chosen most desirable by VLR:	
[ReceivedSignalQuality]	Raw received signal strength from MS.	R
[ControlChannelData]	Includes: DCC and CHNO of analog access channel, and CMAC.	R
[SystemAccessData]	Indicates the Serving MSC and cell site.	R

4.26 RegistrationNotification

The RegistrationNotification (REGNOT) operation is used to report the location of an MS and, optionally, to (a) validate the MS or (b) validate the MS and obtain its profile information. The following table lists the valid combinations of invoking and responding FEs.

Table 27 FE Combinations for REGNOT

	INVOKING FE	RESPONDING FE
Case 1	Serving (or Bordering) MSC	Serving (or Bordering) VLR
Case 2	Serving (or Bordering) VLR	HLR

One of several possible results is returned:

1. An indication that authorization is confirmed with an indication of the authorization duration (e.g., per call, eight hours, one day).
2. Item 1 along with the MS's calling capabilities (i.e., profile information).
3. Only the MS's calling capabilities.
4. An indication that authorization is denied with reason for denial (e.g., due to an invalid serial number).

4.26.1 Successful RegistrationNotification: Confirmed at the VLR

This operation scenario describes the RegistrationNotification operation when confirmed at the VLR.

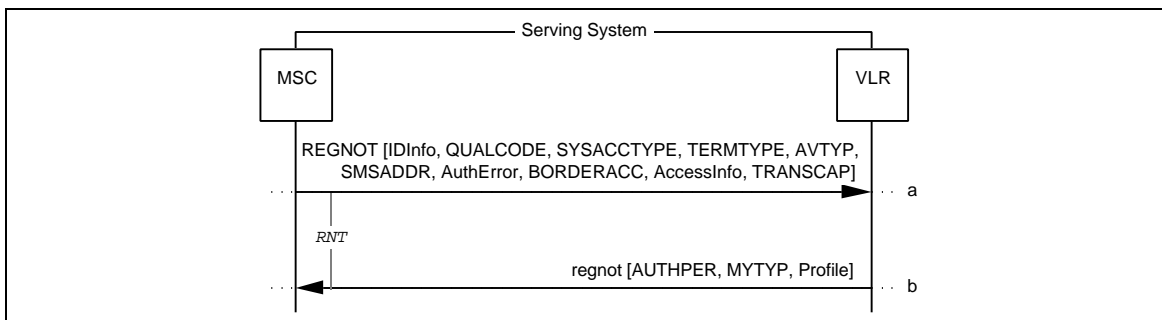

Figure 64 Successful RegistrationNotification: Confirmed at the VLR

- a. The Serving MSC determines that a roaming MS is within its service area; the Serving MSC may detect the MS's presence through autonomous registration, call origination, call termination (i.e., a page response following a call to the roamer port) or a service order. The Serving MSC sends a REGNOT to its VLR.

Parameters	Usage	Type
IDInfo:	Set of identification parameters in REGNOT:	
[MIN]	Served MS MIN.	R
[ESN]	Served MS ESN.	R
[MSCID]	Serving MSC MSCID.	R
[PC_SSN]	Serving MSC PC_SSN. Include if SS7 carriage services are used.	O
[LocationAreaID]	For paging served MS. Include if available.	O
[SystemMyTypeCode]	Serving MSC vendor identification.	MBC
QUALCODE	Type of qualification required.	R
SYSACCTYPE	Type of system access.	R
TRANSCAP	System's transaction capability	R
TERMTYP	Identifies the radio frequency interface standard supported by the associated MS	R
AVTYP	Indicates MS is unavailable for normal call delivery, if applicable.	O
SMSADDR	Temporary routing address of SMS subscriber, if applicable.	O
AuthError:	Parameters included if authentication parameters were requested by the Serving MSC but not received from the MS:	O
[SystemCapabilities]	Authentication capabilities of serving system.	
[ReportType]	Report of missing authentication parameters.	
BORDACC	Indicates that system access is in a border cell, as determined by local procedures.	O

continued on next page...

1
2
3 ...continued from previous page
4

Parameters	Usage	Type
AccessInfo: [ReceivedSignalQuality] [ControlChannelData] [SystemAccessData]	Subscriber's access information. Included if system access is in a border cell. Includes: Raw received signal strength from MS for use in multiple access signal strength arbitration. Includes: DCC and CHNO of analog access channel for use in multiple access detection; CMAC for use in signal strength arbitration. Indicates the Serving MSC and cell site for use in multiple access detection.	O
ChargingAreaInformation	Indicates charge area for the served MS.	O
CarrierIdentificationCode	Indicates carrier identification code for the served MS.	O

*
*
*

- 5
6
7
8
9
10
11
12
13
14
15
16
17
18
19
20
21 b. The Serving VLR determines that (a) the MS had previously registered with an MSC
22 within the domain of the VLR, (b) the MS is in the active state (c) this is not a
23 multiple access situation, and (d) the requested information is available for the
24 indicated MS.
25

26 Under these conditions, the Serving VLR records the identity of the MSC currently
27 serving the MS and the location area identity (if applicable) of the MS. It then sends
28 a **regnot** to the Serving MSC.
29

Parameters	Usage	Type
AUTHPER	Authorization confirmed indication with period of authorization.	O
MYTYP	VLR vendor identification.	MBC
Profile: [CallingFeatures-Indicator] [OriginationIndicator] [Digits(Restriction)] [Termination-RestrictionCode]	Subscriber's profile information. Include if profile requested in QUALCODE: Authorization and activity states for features. Type of calls MS is allowed to originate. Selected leading digits or full Directory Number allowed for call origination as indicated in OriginationIndicator. Include if applicable. Type of calls MS is allowed to terminate.	O

30
31
32
33
34
35
36
37
38
39
40
41
42
43
44
45
46
47
48 continued on next page...
49
50
51
52
53
54
55
56
57
58
59
60

1
2
3 ...continued from previous page
4

Parameters	Usage	Type
[Digits(Carrier)]	Indicates MS's preferred IC, if applicable.	
[RoutingDigits]	Special routing instructions, if applicable.	
[Geographic- Authorization]	Include if applicable.	
[Authentication- Capability]	Include if authentication of MS is required.	
[DMH_AccountCode- Digits]	Include if applicable.	
[DMH_AlternateBilling- Digits]	Include if applicable.	
[DMH_BillingDigits]	Include if applicable.	
[MobileDirectory- Number]	Include if applicable.	
[MessageWaiting- NotificationCount]	Include if MessageWaitingNotificationType is <i>Count Indication</i> .	
[MessageWaiting- NotificationType]	Include if Message Waiting Notification feature is active and an action is required.	
[OriginationTriggers]	Origination trigger points currently active for the subscriber. Include if applicable.	
[PACAIndicator]	Indicates the PACA permanent activation status and priority level assigned to the subscriber, if applicable.	
[PreferredLanguage- Indicator]	Indicates the preferred language associated with the subscriber, if applicable.	
[SMS_Origination- Restrictions]	Defines the type of messages the MS is allowed to originate, if applicable.	
[SPINIPIN]	Indicates Subscriber's PIN, if applicable.	
[SPINITriggers]	SPINI trigger points currently active for the subscriber. Include if applicable.	
[SMS_Termination- Restrictions]	Defines the type of messages the MS is allowed to terminate, if applicable.	
[TerminationTriggers]	Termination trigger points currently active for the subscriber. Include if applicable.	
[MobileAdditionalParty's Category3]	Indicates information concerning billing system for the served MS.	* *

4.26.2 Successful RegistrationNotification: Confirmed at the HLR

This operation scenario describes the RegistrationNotification operation when confirmed at the HLR.

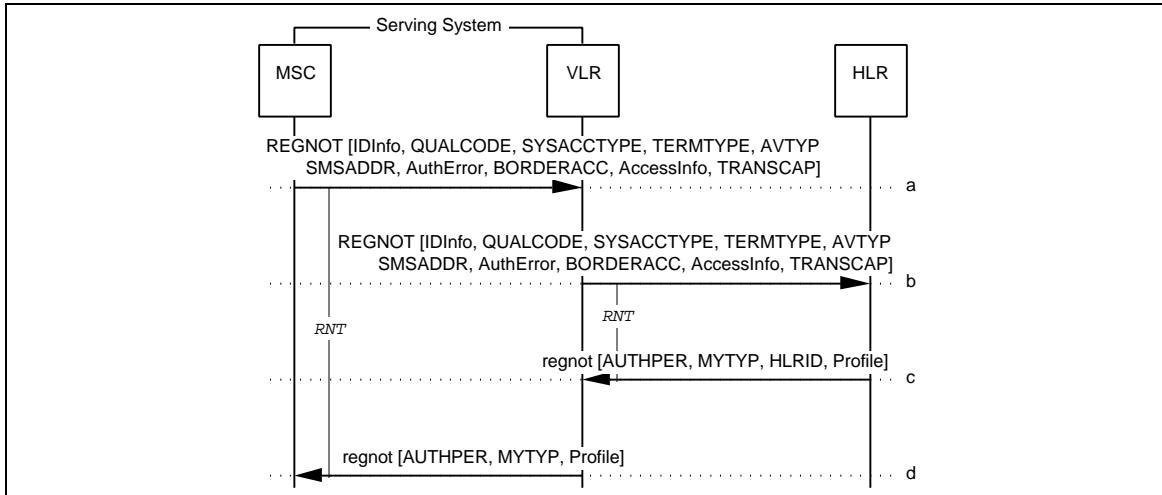

Figure 65 Successful RegistrationNotification: Confirmed at the HLR

1
2
3
4
5
6
7
8
9
10
11
12
13
14
15
16
17
18
19
20
21
22
23
24
25
26
27
28
29
30
31
32
33
34
35
36
37
38
39
40
41
42
43
44
45
46
47
48
49
50
51
52
53
54
55
56
57
58
59
60

- a. Same as Section 4.26.1, Step-a.
- b. The Serving VLR determines that either (a) the MS had previously registered with an MSC within the domain of the VLR but the MS has been reported inactive by the VLR, (b) the MS is not known to the VLR, or (c) the requested information cannot be made available for the indicated MS.

Under these conditions, the Serving VLR forwards the REGNOT to the HLR associated with the MS.

Parameters are as in Step-a, with the following modifications:		
Parameters	Usage	Type
[PC_SSN]	Serving VLR PC_SSN. Include if SS7 carriage services are used.	O
[MYTYP]	Serving VLR vendor identification.	MBC

- c. The HLR determines that authorization can be granted to the MS. It returns the requested information to the Serving VLR in the **regnot**.

Parameters are as in Section 4.26.1, Step-b, with the following additions and modifications:		
Parameters	Usage	Type
HLRID [MSCID]	HLR MSCID to key MS record against for a subsequent UnreliableRoamerDataDirective.	R
MYTYP	HLR vendor identification.	MBC

- d. The VLR forwards the **regnot** to the Serving MSC.

Parameters are as in Step-c, with the exception that the HLRID parameter is not included and with the following modification:		
Parameters	Usage	Type
MYTYP	VLR vendor identification.	MBC

4.26.3 Unsuccessful RegistrationNotification: Denied at the HLR

This operation scenario describes the RegistrationNotification operation when denied at the HLR.

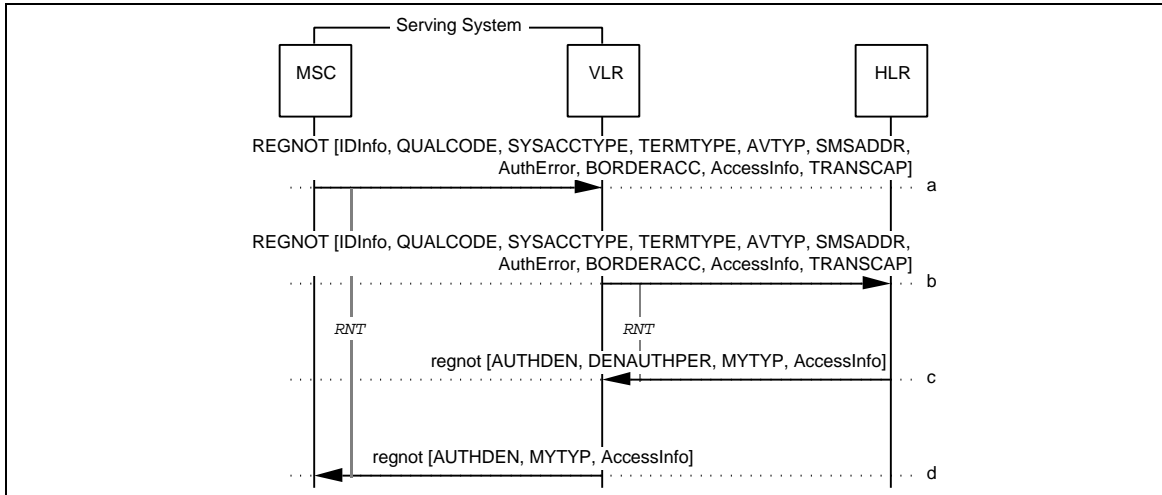

Figure 66 Unsuccessful RegistrationNotification: Denied at the HLR

- a-b. Same as Section 4.26.2, Steps a-b.
- c. The HLR determines that authorization cannot be granted to the MS and returns this indication to the Serving VLR in the **regnot**.

Parameters	Usage	Type
AUTHDEN	Authorization denied indication with reason.	R
DENAUTHPER	Indicates the duration of time that the VLR should retain a record and suppress re-registrations for the authorization-denied MS.	O
MYTYP	HLR vendor identification.	MBC
AccessInfo:	Access information of MS chosen most desirable by HLR. Include if AUTHDEN = <i>Multiple Access</i> .	O
[ReceivedSignalQuality]	Raw received signal strength from MS.	
[ControlChannelData]	Includes: DCC and CHNO of analog access channel, and CMAC.	
[SystemAccessData]	Indicates the Serving MSC and cell site.	

- d. The VLR forwards the **regnot** to the Serving MSC.

Parameters are as in Step-c, with the following modification:

Parameters	Usage	Type
MYTYP	VLR vendor identification.	MBC

4.27 RemoteFeatureControlRequest

This operation is renamed *FeatureRequest* in *IS-41-C*. Refer to Section 4.10 for its definition.

1
2
3
4
5
6
7
8
9
10
11
12
13
14
15
16
17
18
19
20
21
22
23
24
25
26
27
28
29
30
31
32
33
34
35
36
37
38
39
40
41
42
43
44
45
46
47
48
49
50
51
52
53
54
55
56
57
58
59
60

4.28 RemoteUserInteractionDirective

The RemoteUserInteractionDirective (RUIDIR) operation is used by the HLR to remotely direct the operation of an MSC (or other network node) which provides user interaction; i.e., the RUI-MSC. The RUI-MSC may be an Originating MSC, a Serving MSC or some other network node capable of user interaction.

The following table lists the valid combinations of invoking and responding FEs.

Table 28 FE Combinations for RUIDIR

	INVOKING FE	RESPONDING FE
Case 1	HLR	RUI-MSC

4.28.1 Successful RemoteUserInteractionDirective

This operation scenario describes a normal RemoteUserInteractionDirective operation.

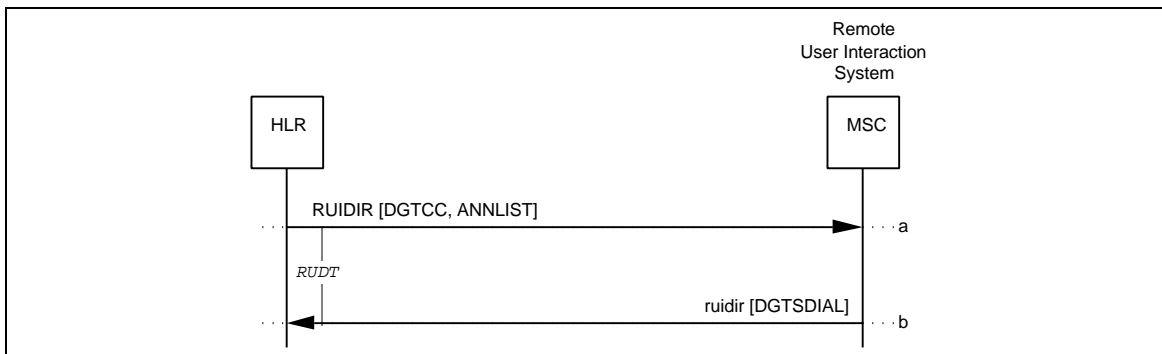

Figure 67 Successful RemoteUserInteractionDirective

- a. The HLR sends a RUI DIR to the RUI-MSC to direct it to perform a specified user interaction operation (e.g., play announcement and collect digits).

Parameters	Usage	Type
DGTCC	Specifies digit collection parameters	R
ANNLIST	List of tones or announcements to play.	R

- b. The RUI-MSC performs the requested user interaction and returns the result (if any) in the rui di r.

Parameters	Usage	Type
DGTSDIAL	Digits collected from user.	O

4.28.2 Unsuccessful RemoteUserInteractionDirective

This operation scenario describes a normal RemoteUserInteractionDirective operation.

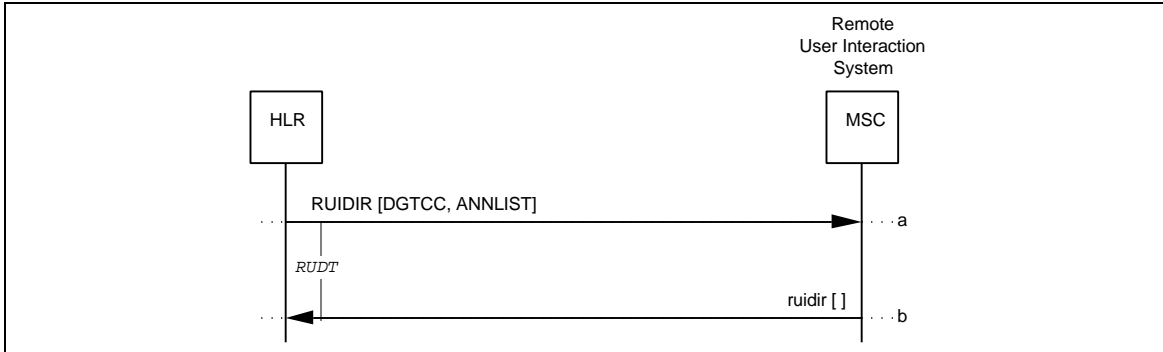

Figure 68 Unsuccessful RemoteUserInteractionDirective

- a. The HLR sends a RUI DIR to the RUI-MSC to direct it to perform a specified user interaction operation (e.g., play announcement and collect digits).

Parameters	Usage	Type
DGTCC	Specifies digit collection parameters	R
ANNLIST	List of tones or announcements to play.	R

- b. The RUI-MSC performs the requested user interaction and returns an empty rui di r, indicating that the call has been abandoned.

4.29 RoutingRequest

The RoutingRequest (ROUTREQ) operation is used to inquire as to the preferred method of routing a pending call to the identified MS. The following table lists the valid combinations of invoking and responding FEs.

Table 29 FE Combinations for ROUTREQ

	INVOKING FE	RESPONDING FE
Case 1	HLR	Serving VLR
Case 2	Serving VLR	Serving MSC
Case 3	HLR	Serving MSC

Case 3 above is termed a 'direct' RoutingRequest operation, since it occurs directly between the HLR and the Serving MSC without the involvement of the VLR (e.g., voice mail delivery, voice mail storage, special dialogue).

One of several possible results is returned:

1. A Temporary Local Directory Number (TLDN) assigned by the Serving MSC (see Sections 4.30.1 and 4.30.2 for the indirect and direct cases, respectively).
2. A TLDN along with an indication that access to the identified MS is denied along with the reason for denial (not shown in this section).
3. An indication that access to the identified MS is denied along with the reason for denial (see Section 4.30.3).

4.29.1 Successful Indirect RoutingRequest: TLDN Returned

This operation scenario describes a successful indirect RoutingRequest operation (i.e., via the VLR), with a TLDN returned.

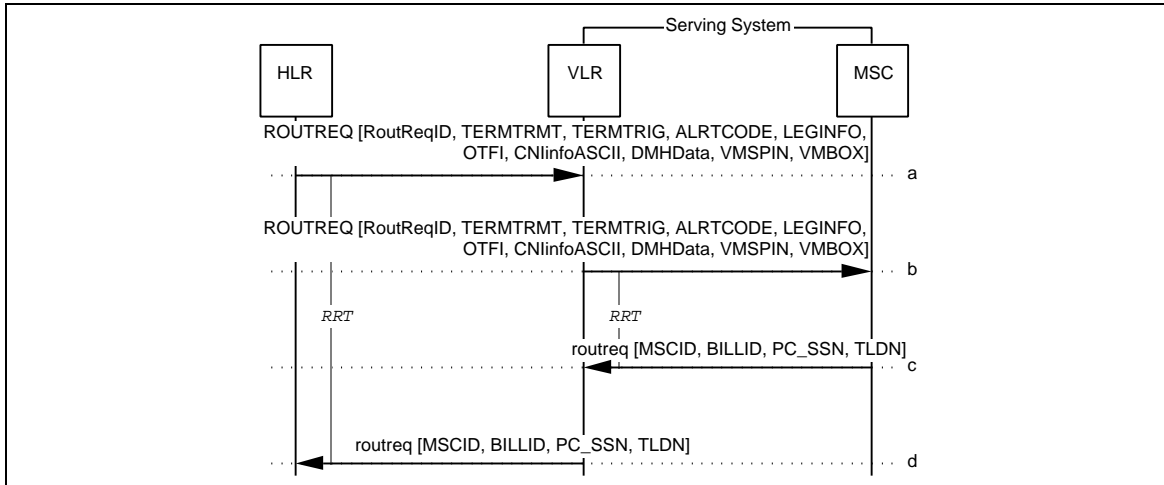

Figure 69 Successful Indirect RoutingRequest: TLDN Returned

a. The HLR sends a ROUTREQ to the Serving VLR.

Parameters	Usage	Type
RoutReqID	Set of identification parameters in ROUTREQ:	
[BillingID]	Call ID for billing and redirection purposes.	R
[MIN]	Served MS MIN.	R
[ESN]	Served MS ESN.	R
[MSCID]	Originating MSC MSCID for use in any subsequent redirection.	R
[SystemMyTypeCode]	Originating MSC vendor identification.	MBC
[PC_SSN]	Originating MSC PC_SSN. Include if SS7 carriage services are used.	O
[LocationAreaID]	For paging purposes. Include if available.	O
TERMTRMT	Indicates termination type. Include if other than termination to MS.	O
TERMTRIG	Termination trigger points currently active for the MS. Include if applicable.	O
ALRTCODE	Type of alert signal to apply. Include if special alerting is to be applied to the MS.	O
LEGINFO	Identifies a leg in a multiple termination call. Include if applicable.	O
OTFI	Indicates that modification to normal feature processing is required for this call. Include if applicable.	O
CNIinfoASCII:	CNI information including digits parameters in ASCII format. Include as applicable:	
[CallingPartyNumber-String1]	Calling number digits (network-provided), incl. presentation restriction information.	O
[CallingPartyNumber-String2]	Calling number digits (user-provided), incl. presentation restriction information.	O
[RedirectingNumber-String]	Redirecting number digits, incl. presentation restriction information.	O
[CallingPartySubaddress]	Calling number subaddress (user-provided).	O
[RedirectingSubaddress]	Redirecting number subaddress.	O

continued on next page...

...continued from previous page

Parameters	Usage	Type
DMHData:	Data for <i>DMH</i> recording purposes:	
[DMH_AccountCode-Digits]	Include if applicable.	O
[DMH_AlternateBilling-Digits]	Include if applicable.	O
[DMH_BillingDigits]	Include if applicable.	O
[MobileDirectory-Number]	Include if applicable.	O
VMSPIN	May include if TerminationTreatment indicates termination to a voice mailbox.	O
VMBOX	Voice mailbox number. Include if TerminationTreatment indicates termination to a voice mailbox which is not identified by the MIN.	O

- b. The VLR forwards the ROUTREQ to the Serving MSC. Parameters are as in Step -a.
- c. If TerminationTreatment indicates termination to an MS, the Serving MSC consults its internal data structures to determine if the MS is already engaged in a call on this MSC. If termination is to a voice mailbox, the Serving MSC will verify the VMS availability. Finding the MS or VMS able to accept incoming calls, the Serving MSC allocates a TLDN (Temporary Local Directory Number) and returns this information to the VLR in the routreq.

Parameters	Usage	Type
MSCID	Serving MSC MSCID for use in subsequent inter- MSC call.	R
BILLID	Terminating billing ID. Required for recording purposes.	R
TLDN [DGTSDEST]	Temporary Local Directory Number for inter- MSC call routing.	R
PC_SSN	Serving MSC PC_SSN. Include if SS7 carriage services are used.	O
ChargingAreaInformation	Indicates charge area for the MS.	O
CarrierIdentificationCode	Indicates carrier identification code for the MS.	O

*
*

- d. The VLR forwards the routreq to the HLR. Parameters are as in Step-c.

4.29.2 Successful Direct RoutingRequest: TLDN Returned

This operation scenario describes a successful direct RoutingRequest operation (i.e., directly between HLR and MSC), with a TLDN returned.

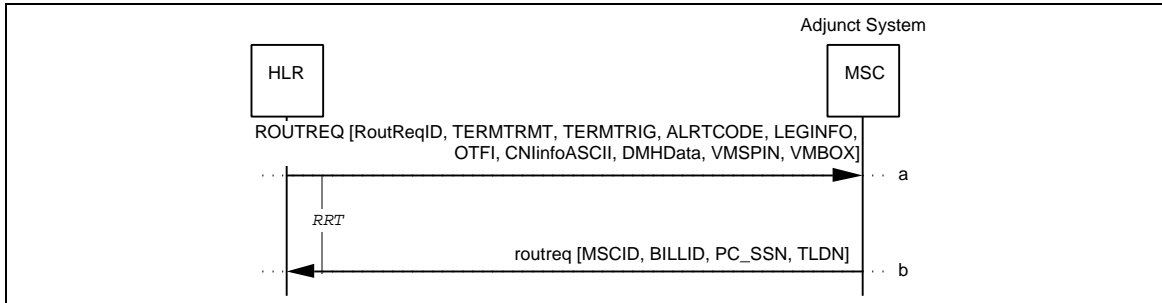

Figure 70 Successful Direct RoutingRequest: TLDN Returned

- a. The HLR sends a **ROUTREQ** to the Adjunct MSC. Parameters are as in Section 4.29.1, Step-a.
- b. If the required resources are available, the Adjunct MSC allocates a TLDN (Temporary Local Directory Number) and returns this information to the HLR in the **routreq**. Parameters are as in Section 4.29.1, Step-c.

4.29.3 Unsuccessful Indirect RoutingRequest: Access Denied Returned

This operation scenario describes an unsuccessful indirect RoutingRequest operation (i.e., via the VLR), with an indication that access is denied returned.

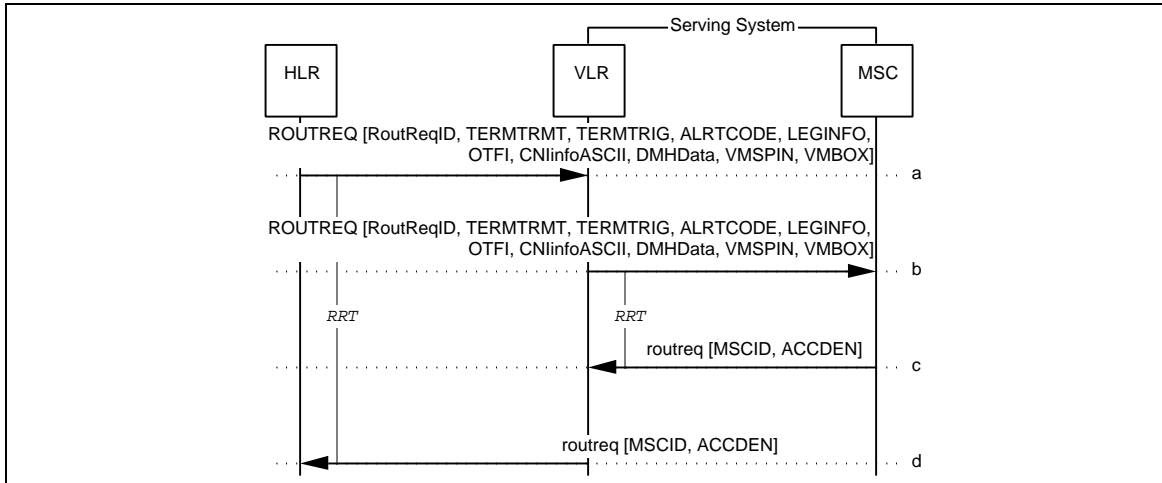

Figure 71 Unsuccessful RoutingRequest: Access Denied Returned

- a-b. Same as Section 4.29.1, Steps a-b.
- c. If TerminationTreatment indicates termination to an MS, the Serving MSC consults its internal data structures to determine if the MS is already engaged in a call on this MSC. If termination is to a voice mailbox, the Serving MSC will verify the VMS availability. Finding the MS or VMS busy (or otherwise unable to receive calls), the Serving MSC returns an appropriate indication to the VLR in the **routreq**.

Parameters	Usage	Type
MSCID	Serving MSC MSCID.	MBC
ACCDEN	Reason for denying access.	R

- d. The VLR forwards the **routreq** to the HLR. Parameters are as in Step-c.

4.30 SMSDeliveryBackward

The SMSDeliveryBackward (SMDBACK) operation is a general purpose operation that is used to convey an MS-originated short message or in general any other information or encapsulated data to the Anchor MSC after handoff.

The following table lists the valid combinations of invoking and responding FEs.

Table 30 FE Combinations for SMDBACK

	INVOKING FE	RESPONDING FE	When
Case 1	Serving MSC	Anchor MSC	Message delivery with no tandem.
Case 2	Serving MSC	Tandem MSC	Message delivery with tandem(s).
Case 3	Tandem MSC	Tandem MSC	Message delivery with tandems.
Case 4	Tandem MSC	Anchor MSC	Message delivery with tandem(s).

The SMSDeliveryBackward operation has two variations:

1. Successful transfer of a short message to another point.
2. Unsuccessful transfer of a short message to another point.

4.30.1 Successful SMSDeliveryBackward

This scenario describes the successful use of the SMSDeliveryBackward operation.

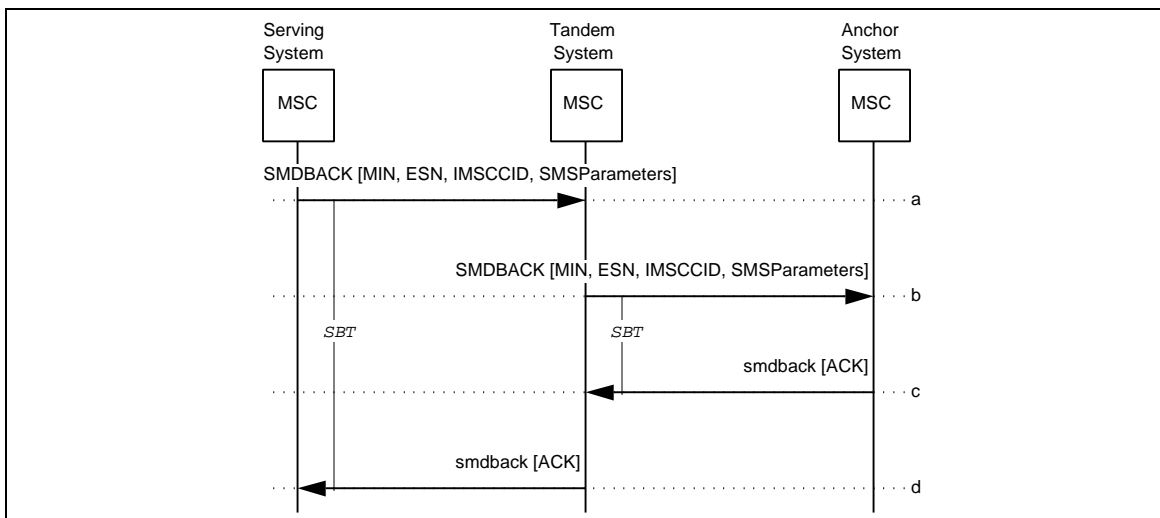

Figure 72 Successful SMSDeliveryBackward

- 1
2
3 a. Following an intersystem handoff, the Serving MSC receives a short message from the
4 served MS; therefore, it sends an **SMDBACK** toward the Anchor MSC, via a Tandem
5 MSC.

6
7
8
9
10
11
12
13
14
15
16
17
18
19
20
21
22
23
24
25
26
27
28
29

Parameters	Usage	Type
MIN	Used to identify the MS.	R
ESN	Used to identify the MS.	R
IMSCCID	Specifies the trunk in a dedicated trunk group between the two MSCs for the MS involved.	R
SMSParameters:	Set of SMS parameters:	
[SMS_BearerData]	Used to transport the bearer data.	R
[SMS_TeleService- Identifier]	Identification of the teleservice, used for interpreting the bearer data.	R
[SMS_Original- DestinationAddress]	Network address of the destination SME.	R
[SMS_Original- OriginatingAddress]	Network address of the originating SME.	R
[SMS_ChargeIndicator]	Include to specify charging option	O
[SMS_Original- DestinationSubaddress]	Subaddress of the destination SME. Include if available.	O
[SMS_Original- OriginatingSubaddress]	Subaddress of the originating SME. Include if available.	O

- 30
31 b. The Tandem MSC adjusts the InterMSCCircuitID parameter to identify the circuit
32 between it and the Anchor MSC, and forwards the **SMDBACK** to the Anchor MSC.
33 Parameters are as in Step-a.
34
35 c. The Anchor MSC returns an **smdback**, indicating positive acknowledgment of the
36 operation invocation. The **smdback** may include an **SMS_BearerData** parameter if
37 there is bearer data to return.

38
39
40
41
42

Parameters	Usage	Type
ACK:	Positive acknowledgment signal:	
[SMS_BearerData]	Used to transport the bearer data, if available.	O

- 43 d. The Tandem MSC forwards the **smdback** to the Serving MSC.
44
45
46
47
48
49
50
51
52
53
54
55
56
57
58
59
60

4.30.2 Unsuccessful SMSDeliveryBackward

This scenario describes the unsuccessful use of the SMSDeliveryBackward operation.

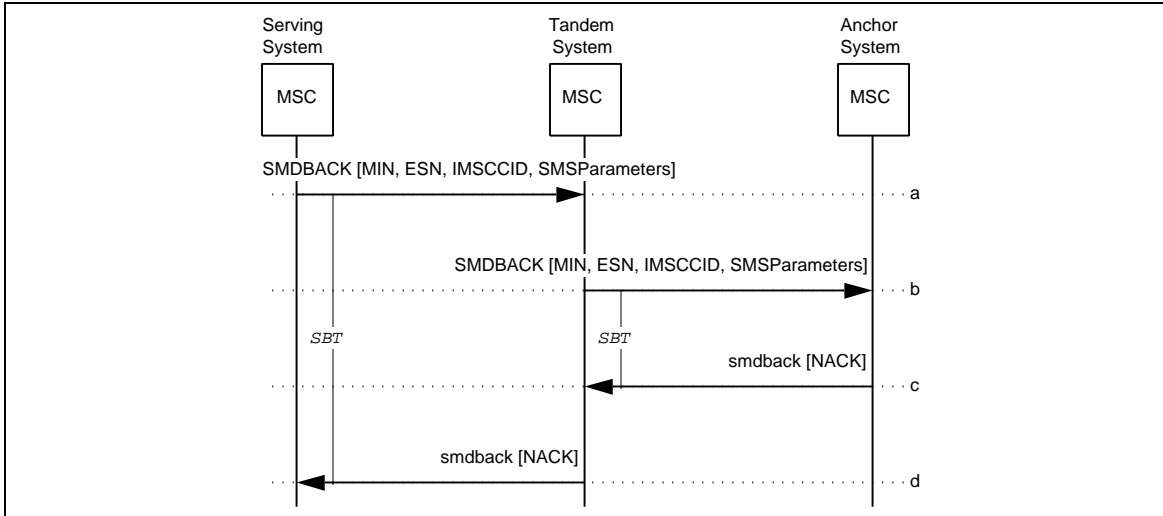

Figure 73 Unsuccessful SMSDeliveryBackward

- a-b. Same as Section 4.30.1, Steps a-b.
- c. The Anchor MSC returns an `smdback`, indicating negative acknowledgment of the operation invocation via the inclusion of an `SMS_CauseCode` parameter.

Parameters	Usage	Type
NACK: [SMS_CauseCode]	Negative acknowledgment signal: Indicates the reason for not delivering the SMS message.	R

- d. The Tandem MSC forwards the `smdback` to the Serving MSC.

4.31 SMSDeliveryForward

The SMSDeliveryForward (SMDFWD) operation is a general purpose operation that is used to convey an MS-terminated short message or in general any other information or encapsulated data to the Serving MSC after handoff.

The following table lists the valid combinations of invoking and responding FEs.

Table 31 FE Combinations for SMDFWD

	INVOKING FE	RESPONDING FE	When
Case 1	Anchor MSC	Serving MSC	Message delivery with no tandem.
Case 2	Anchor MSC	Tandem MSC	Message delivery with tandem(s).
Case 3	Tandem MSC	Tandem MSC	Message delivery with tandems.
Case 4	Tandem MSC	Serving MSC	Message delivery with tandem(s).

The SMSDeliveryForward operation has two variations:

1. Successful transfer of a short message to another point.
2. Unsuccessful transfer of a short message to another point.

4.31.1 Successful SMSDeliveryForward

This scenario describes the successful use of the SMSDeliveryForward operation when the handoff chain includes a Tandem MSC.

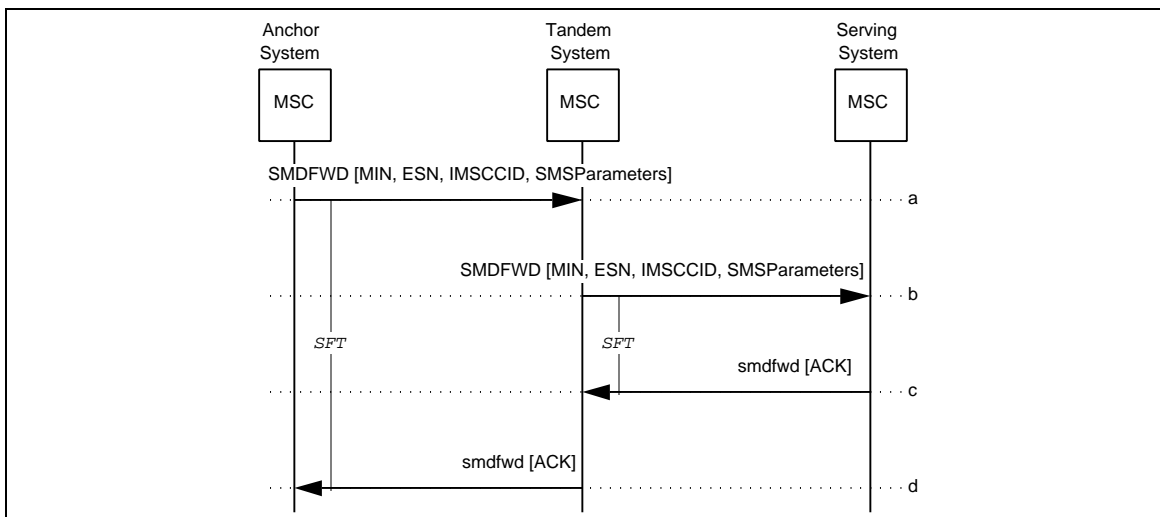

Figure 74 Successful SMSDeliveryForward

1
2
3
4
5
6
7
8
9
10
11
12
13
14
15
16
17
18
19
20
21
22
23
24
25
26
27
28
29
30
31
32
33
34
35
36
37
38
39
40
41
42
43
44
45
46
47
48
49
50
51
52
53
54
55
56
57
58
59
60

- a. Following an intersystem handoff, the Anchor MSC receives a short message destined for the served MS; therefore, it sends an **SMDPWD** toward the Serving MSC, via a Tandem MSC.

Parameters	Usage	Type
MIN	Used to identify the MS.	R
ESN	Used to identify the MS.	R
IMSCCID	Specifies the trunk in a dedicated trunk group between the two MSCs for the MS involved.	R
SMSParameters:	Set of SMS parameters:	
[SMS_BearerData]	Used to transport the bearer data.	R
[SMS_TeleService-Identifier]	Identification of the teleservice, used for interpreting the bearer data.	R
[SMS_Original-DestinationAddress]	Network address of the destination SME.	R
[SMS_Original-OriginatingAddress]	Network address of the originating SME.	R
[SMS_ChargeIndicator]	Include to specify charging option.	O
[SMS_Original-DestinationSubaddress]	Subaddress of the destination SME. Include if available.	O
[SMS_Original-OriginatingSubaddress]	Subaddress of the originating SME. Include if available.	O

- b. The Tandem MSC adjusts the **InterMSCCircuitID** parameter to identify the circuit between it and the Serving MSC, and forwards the **SMDPWD** to the Serving MSC. Parameters are as in Step-a.
- c. The Serving MSC returns an **smdfwd**, indicating positive acknowledgment of the operation invocation. The **smdfwd** may include an **SMS_BearerData** parameter if there is bearer data to return.

Parameters	Usage	Type
ACK:	Positive acknowledgment signal:	
[SMS_BearerData]	Used to transport the bearer data, if available.	O

- d. The Tandem MSC forwards the **smdfwd** to the Anchor MSC.

4.31.2 Unsuccessful SMSDeliveryForward

This scenario describes the unsuccessful use of the SMSDeliveryForward operation when the handoff chain includes a Tandem MSC.

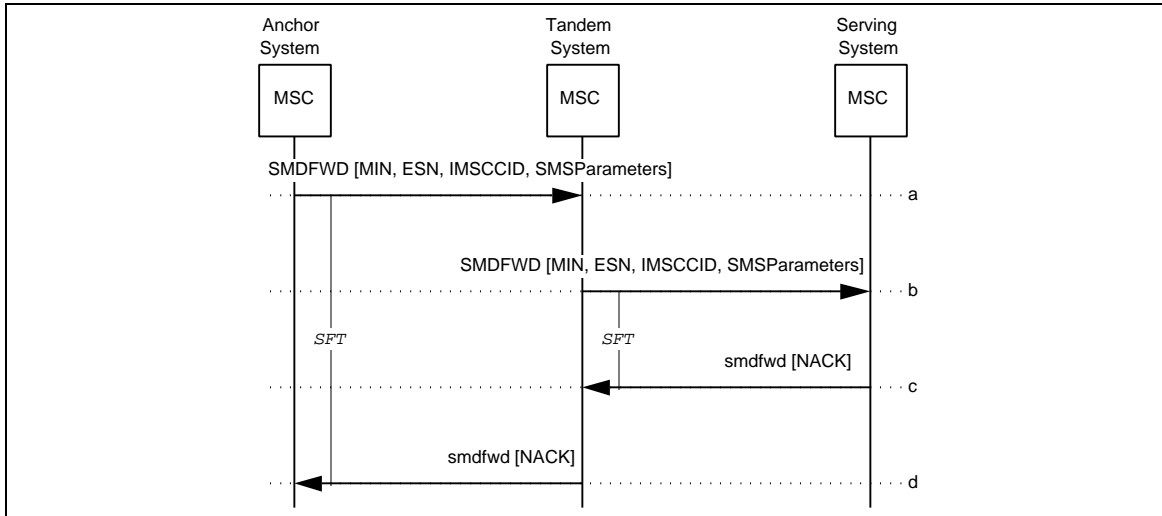

Figure 75 Unsuccessful SMSDeliveryForward

- a-b. Same as Section 4.31.1, Steps a-b.
- c. The Serving MSC returns an `smdfwd`, indicating negative acknowledgment of the operation invocation via the inclusion of an `SMS_CauseCode` parameter.

Parameters	Usage	Type
NACK: [SMS_CauseCode]	Negative acknowledgment signal: Indicates the reason for not delivering the SMS message.	R

- d. The Tandem MSC forwards the `smdfwd` to the Anchor MSC.

4.32 SMSDeliveryPointToPoint

The SMSDeliveryPointToPoint (SMDPP) operation is a general purpose operation that is used to transfer a short message or in general any other information or encapsulated data from one point to another point and report on the success or failure of that transfer.

The following table lists the valid combinations of invoking and responding FEs.

Table 32 FE Combinations for SMDPP

	INVOKING FE	RESPONDING FE	When
Case 1	SME	MC	Message origination
Case 2	MC	MC	Message transition from originating MC control to destination control
Case 3	MC	SME	Message delivery
Case 4	SME	SME	Message origination to delivery

The SMSDeliveryPointToPoint operation has two variations:

1. Successful transfer of a short message to another point.
2. Unsuccessful transfer of a short message to another point.

4.32.1 Successful SMSDeliveryPointToPoint

This scenario describes the successful use of the SMSDeliveryPointToPoint operation.

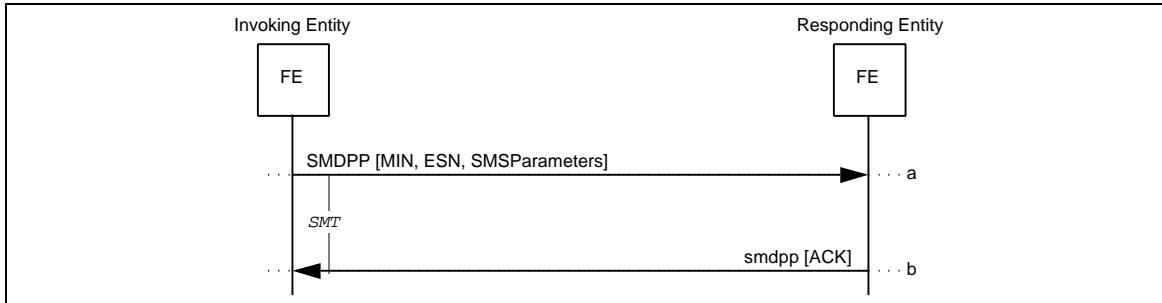

Figure 76 Successful SMSDeliveryPointToPoint

- a. The sending network element sends a SMDPP toward the destination network element.

Parameters	Usage	Type
MIN	Served MS MIN. Include if known.	O
ESN	Served MS ESN. Include if known.	O
SMSParameters:	Set of SMS parameters:	
[SMS_BearerData]	Used to transport the bearer data.	R
[SMS_Tele-service-Identifier]	Identification of the teleservice; used for interpreting the bearer data.	R
[SMS_Original-DestinationAddress]	Network address of the destination SME.	R
[SMS_Original-OriginatingAddress]	Network address of the originating SME.	R
[SMS_ChargeIndicator]	Include to specify charging option.	O
[SMS_Original-DestinationSubaddress]	Subaddress of the destination SME. Include if available.	O
[SMS_Original-OriginatingSubaddress]	Subaddress of the originating SME. Include if available.	O
[SMS_MessageCount]	Include to indicate the number of pending SMS messages for the SME.	O
[SMS_Notification-Indicator]	Include to control the subsequent notification of when the MS becomes available.	O

1
2
3
4
5
6
7
8
9
10
11
12
13
14
15
16
17
18
19
20
21
22
23
24
25
26
27
28
29
30
31
32
33
34
35
36
37
38
39
40
41
42
43
44
45
46
47
48
49
50
51
52
53
54
55
56
57
58
59
60

- b. The receiving network element returns an **smdpp**, indicating positive acknowledgment of the operation invocation. The **smdpp** may include an **SMS_BearerData** parameter if there is bearer data to return.

Parameters	Usage	Type
ACK: [SMS_BearerData]	Positive acknowledgment signal: Used to transport the bearer data, if available.	O

4.32.2 Unsuccessful SMSDeliveryPointToPoint

This scenario describes the unsuccessful use of the SMSDeliveryPointToPoint operation.

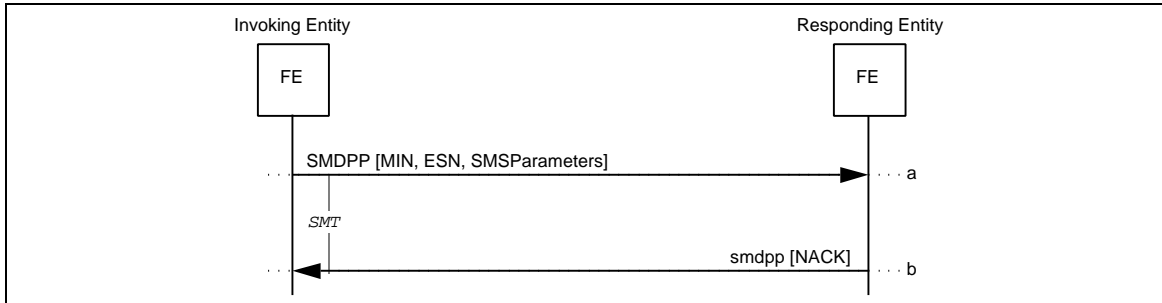

Figure 77 Unsuccessful SMSDeliveryPointToPoint

- a. Same as Section 4.32.1, Step-a.
- b. The receiving network element returns an `smdpp`, indicating negative acknowledgment of the operation invocation via the inclusion of an `SMS_CauseCode` parameter.

Parameters	Usage	Type
NACK: [SMS_CauseCode]	Negative acknowledgment signal: Indicates the reason for not delivering the SMS message.	R

4.33 SMSNotification

The SMSNotification (SMSNOT) operation is used to report a change in an MS's ability to receive SMS messages based on the location or status of the MS. This message, at a minimum, is used to report the accessibility of an MS following a postponed SMSRequest or SMSDeliveryPointToPoint. This message may also be used to revoke delivery permission previously granted with either an SMSRequest or an SMSNotification.

The following table lists the valid combinations of invoking and responding FEs.

Table 33 FE Combinations for SMSNOT

	INVOKING FE	RESPONDING FE	When
Case 1	HLR	MC	To report a change in an MS's ability to receive SMS messages.
Case 2	MSC	MC	To report a change in an MS's ability to receive SMS messages.

The SMSNotification operation has two variations:

1. Used to report MS-based SME availability.
2. Used to report MS-based SME unavailability.

4.33.1 Successful SMSNotification: MS-Based SME Availability Report

This scenario describes the successful use of the SMSNotification operation, conveying to the MC the SMS_Address of an MS-based SME.

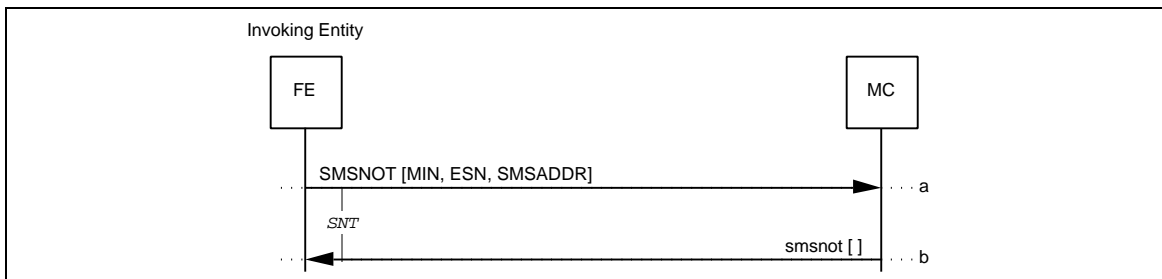

Figure 78 Successful SMSNotification: MS-Based SME Availability Report

- a. The Invoking FE detects a change of an MS's status or location indicating the availability of an MS-based SME. The Invoking FE may send an **SMSNOT** to the responsible MC. If the Invoking FE has a pending request for the address of an MS-based SME, it must respond.

Parameters	Usage	Type
MIN	Used to identify the MS.	R
ESN	Used to identify the MS.	R
SMSADDR	Temporary routing address that can be used to deliver one or more short messages to the indicated MS.	R

- b. The MC confirms the receipt of the address by returning an **smsnot** to the Invoking FE.

4.33.2 Successful SMSNotification: MS-Based SME Unavailability Report

This scenario describes the successful use of the SMSNotification operation, revoking a previously granted permission to send SMS messages.

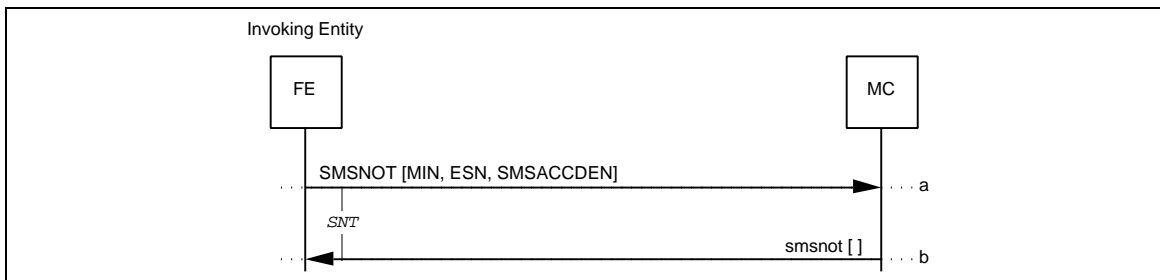

Figure 79 Successful SMSNotification: MS-Based SME Unavailability Report

- a. The Invoking FE detects a change of an MS's status or location indicating the unavailability of an MS-based SME previously granted permission to send. The Invoking FE may send a **SMSNOT** to the responsible MC.

Parameters	Usage	Type
MIN	Used to identify the MS.	R
ESN	Used to identify the MS.	R
SMSACCDEN	Reason why messages cannot be delivered to the MS.	R

- b. The MC confirms the receipt of the status change by sending a **smsnot**.

4.34 SMSRequest

The SMSRequest (SMSREQ) operation is used to request a roaming MS's temporary SMS routing address.

The following table lists the valid combinations of invoking and responding FEs.

Table 34 FE Combinations for SMSREQ

	INVOKING FE	RESPONDING FE	When
Case 1	MC	HLR	MS's SMS routing address is required.
Case 2	HLR	Serving VLR	HLR does not have current address.
Case 3	Serving VLR	Serving MSC	SMSREQ received by Serving VLR.

The SMSRequest operation has two variations:

1. Successful address request, with address returned.
2. Unsuccessful address request, with reason returned.

4.34.1 Successful SMSRequest: MS-Based SME Address Request

This scenario describes the successful use of the SMSRequest operation, resulting in the return of the SMS_Address of an MS-based SME to the MC.

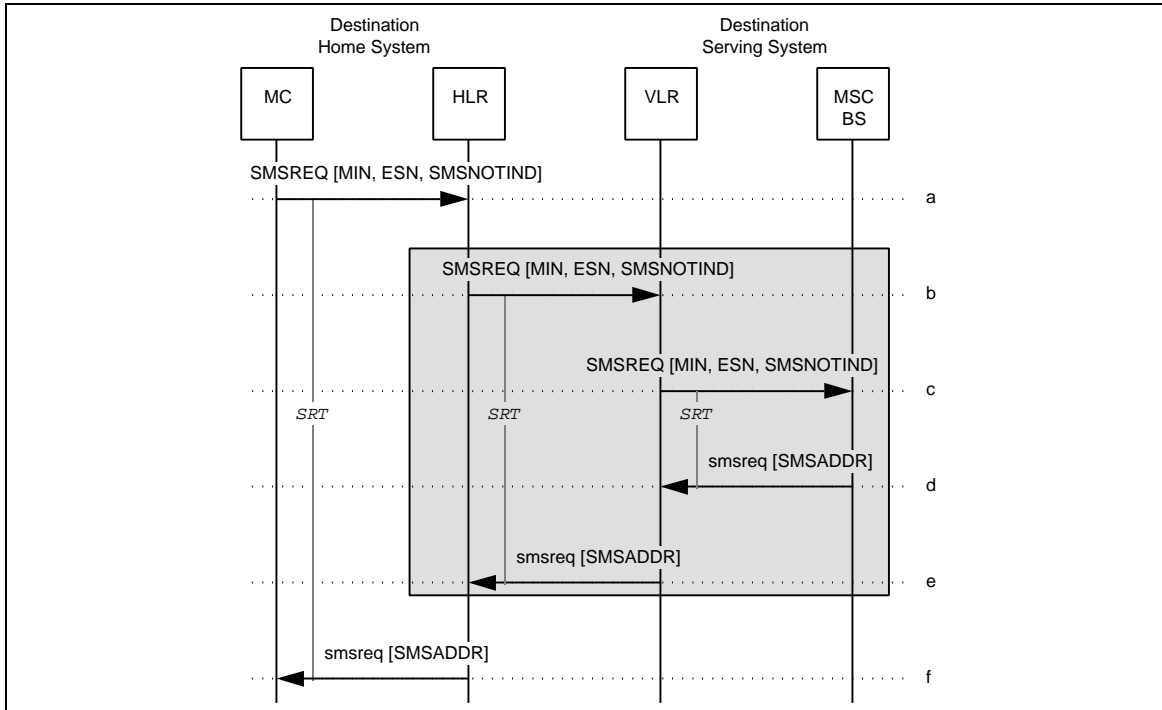

Figure 80 Successful SMSRequest: MS-Based SME Address Request

- a. If the MC does not have the current network address of the indicated MS-based SME, it sends a SMSREQ toward the HLR (possibly using SCCP global title translation of the MIN).

Parameters	Usage	Type
MIN	Used to identify the MS.	R
ESN	Used to identify the MS.	O
SMSNOTIND	Include if a notification of MS availability is not required.	O

- b. If the HLR has the current address of indicated MS-based SME, proceed to Step-f; otherwise, the HLR forwards the SMSREQ toward the VLR serving the addressed MS-based SME. Parameters are as in Step-a.
- c. The VLR forwards the SMSREQ toward the MSC serving the addressed MS-based SME. Parameters are as in Step-a.
- d. The Serving MSC returns an smsreq to the VLR indicating the current network address that can be associated with the indicated MS-based SME.

Parameters	Usage	Type
SMSADDR	Temporary routing address that can be used to deliver one or more short messages to the indicated MS.	R

- e. The VLR forwards the `smsreq` to the requesting HLR. Parameters are as in Step-d.
- f. The HLR sends an `smsreq` to the requesting MC. Parameters are as in Step-d.

4.34.2 Unsuccessful SMSRequest: MS-Based SME Address Request

This scenario describes the unsuccessful use of the SMSRequest operation, resulting in the reason why short messages cannot be delivered to an MS-based SME.

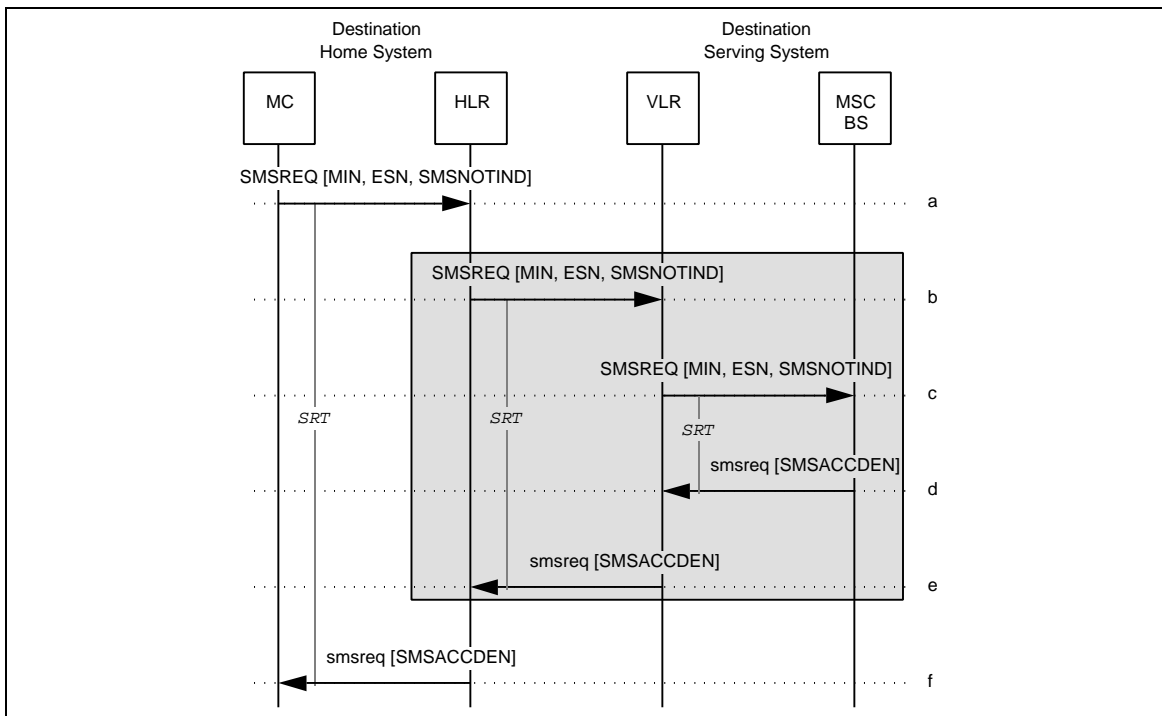

Figure 81 Unsuccessful SMSRequest: MS-Based SME Address Request

- a-c. Same as Section 4.34.1, Steps a-c.
- d. The Serving MSC returns an `smsreq` to the VLR indicating the reason why SMS messages cannot be delivered to the indicated MS-based SME.

Parameters	Usage	Type
SMSACCDEN	Reason why messages cannot be delivered to the MS-based SME.	R

- e. The VLR forwards the `smsreq` to the requesting HLR. Parameters are as in Step-d.
- f. The HLR sends an `smsreq` to the requesting MC. Parameters are as in Step-d.

1
2
3
4
5
6
7
8
9
10
11
12
13
14
15
16
17
18
19
20
21
22
23
24
25
26
27
28
29
30
31
32
33
34
35
36
37
38
39
40
41
42
43
44
45
46
47
48
49
50
51
52
53
54
55
56
57
58
59
60

4.35 TransferToNumberRequest

The TransferToNumberRequest (TRANUMREQ) operation is used during feature processing to obtain an MS's forward-to number from the HLR.

The following table lists the valid combinations of invoking and responding FEs.

Table 35 FE Combinations for TRANUMREQ

	INVOKING FE	RESPONDING FE
Case 1	Originating MSC	HLR
Case 2	Serving MSC	HLR

4.35.1 Successful TransferToNumberRequest

This operation scenario describes a normal TransferToNumberRequest operation.

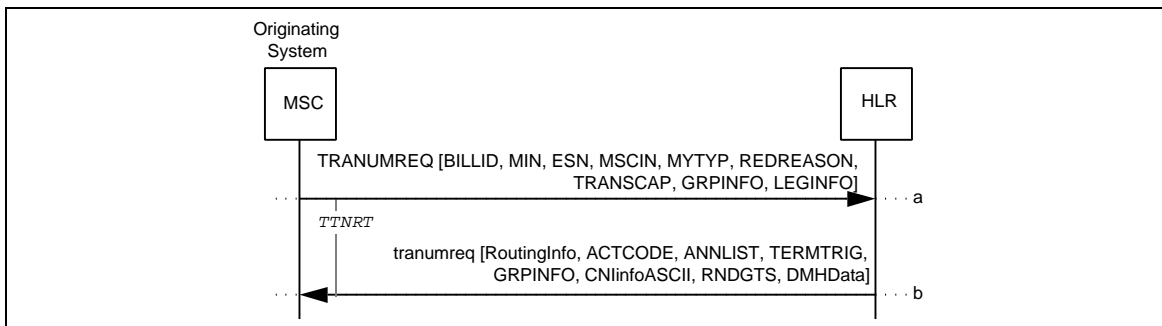

Figure 82 Successful TransferToNumberRequest

- a. The Originating MSC sends a TRANUMREQ to the HLR, including an indication of the feature responsible for redirecting the call (e.g., CFB).

Parameters	Usage	Type
BILLID	Originating BillingID, required to identify instances of Flexible Alerting	
MIN	Served MS MIN.	R
ESN	Served MS ESN.	R
MSCIN	Include for <i>IS-41-C</i> or later.	O
MYTYP	Originating MSC vendor identification.	MBC
REDREASON	Identifies reason for the TRANUMREQ.	R
TRANSCAP	Indicates the originating system's transaction capability at the current time.	R
GRPINFO	Information associated with group routing. Include if available	O
LEGINFO	Identifies a leg in a multiple termination call. Include if available.	O

1
2
3
4
5
6
7
8
9
10
11
12
13
14
15
16
17
18
19
20
21
22
23
24
25
26
27
28
29
30
31
32
33
34
35
36
37
38
39
40
41
42
43
44
45
46
47
48
49
50
51
52
53
54
55
56
57
58
59
60

- b. The HLR determines the forward-to number for redirecting the call and returns this to the Originating MSC in the `tranumreq`.

Parameters	Usage	Type
RoutingInfo: [TerminationList] [Digits(Destination)] [Digits(Carrier)]	Call routing information: Network termination information. Include if TerminationList is allowed. PSTN DN for use in call routing. Include if TerminationList is not allowed. Called subscriber's PIC. Include if applicable and if not specified within the TerminationList parameter.	O O O
ACTCODE	Include if action to be performed is not implied through presence of other parameters.	O
ANMLIST	List of tones or announcements to play. If not included, announcement is based on other parameters in response.	O
TERMTRIG	Termination trigger points currently active for the subscriber. Include if applicable.	O
GRPINFO	Identifies the new leg in a multiple termination call. Include if applicable.	O
CNInfoASCII: [CallingPartyNumber-String1] [CallingPartyNumber-String2] [RedirectingNumber-String] [CallingPartySubaddress] [RedirectingSubaddress]	CNInfo information including digits parameters in ASCII format. Include as applicable: Calling number digits (network-provided), incl. presentation restriction information. Calling number digits (user-provided), incl. presentation restriction information. Redirecting number digits, incl. presentation restriction information. Calling number subaddress (user-provided). Redirecting number subaddress.	O O O O O
RNDGTS	Redirecting number digits in BCD format. May include if call is to be redirected out of the Originating MSC.	O
DMHData: [DMH_AccountCode-Digits] [DMH_AlternateBilling-Digits] [DMH_BillingDigits] [DMH_Redirection-Indicator] [MobileDirectory-Number]	Data for <i>DMH</i> recording purposes: Include if applicable. Include if applicable. Include if applicable. Reason for extending the incoming call. Include for recording purposes. Include if applicable.	O O O R O

4.35.2 Unsuccessful TransferToNumberRequest: Access Denied

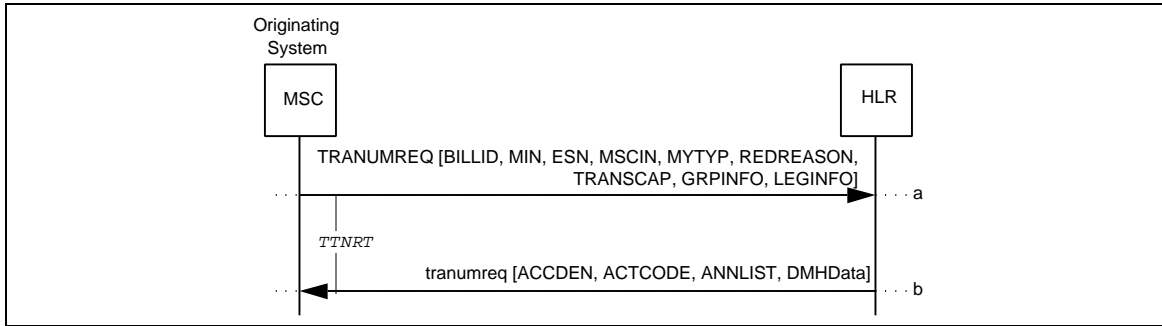

Figure 83 Unsuccessful TransferToNumberRequest: Access Denied

- a. Same as Section 4.35.1, Step-a.
- b. The HLR determines that access cannot be granted to the MS and returns this indication to the Originating MSC in the tranumreq.

Parameters	Usage	Type
ACCDEN	Indicates reason for denying access.	R
ACTCODE	Include if action to be performed is not implied through presence of other parameters.	O
ANNLIST	List of tones or announcements to play. If not included, announcement is based on other parameters in response.	O
DMHData:	Data for DMH recording purposes:	
[DMH_AccountCode-Digits]	Include if applicable.	O
[DMH_AlternateBilling-Digits]	Include if applicable.	O
[DMH_BillingDigits]	Include if applicable.	O
[MobileDirectory-Number]	Include if applicable.	O

4.36 UnreliableRoamerDataDirective

The UnreliableRoamerDataDirective (UNRELDIR) operation is used by the HLR to inform its associated serving systems that it has experienced a failure which has rendered its roaming MS data unreliable.

The following table lists the valid combinations of invoking and responding FEs.

Table 36 FE Combinations for UNRELDIR

	INVOKING FE	RESPONDING FE
Case 1	HLR	Serving VLR

4.36.1 Successful UnreliableRoamerDataDirective

This scenario describes the normal use of the UnreliableRoamerDataDirective operation.

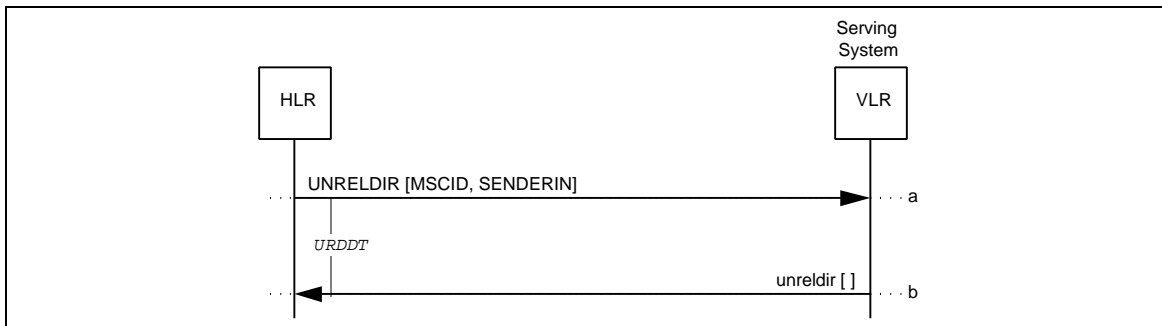

Figure 84 Successful UnreliableRoamerDataDirective

- a. The HLR sends an UNRELDIR to the Serving VLR to inform the VLR that the HLR has experienced a failure which has rendered the HLR's roaming MS data unreliable. The VLR then removes all record of the MS associated with that HLR from its memory.

Parameters	Usage	Type
MSCID [HLR]	HLR MSCID to key MS records against.	R
SENDERIN	The HLR's Sender Identification Number to key MS records against.	O

- b. The Serving VLR acknowledges receipt of the UNRELDIR via an empty unrel dir.

4.37 UnsolicitedResponse

The UnsolicitedResponse (UNSOLRES) operation is used by a Border MSC to notify neighboring MSCs that an unsolicited/unexpected page response has been received from an MS, that the MS's presence in the border system has been confirmed, and that a TLDN has been assigned.

The following table lists the valid combinations of invoking and responding FEs.

Table 37 FE Combinations for UNSOLRESP

	INVOKING FE	RESPONDING FE
Case 1	Border MSC	Serving MSC

The normal response is for the Serving MSC to return the Originating MSC information and call identification to the Border MSC so as to enable subsequent message exchanges between the originating and Border MSCs.

4.37.1 Successful UnsolicitedResponse

This operation scenario describes a normal UnsolicitedResponse operation.

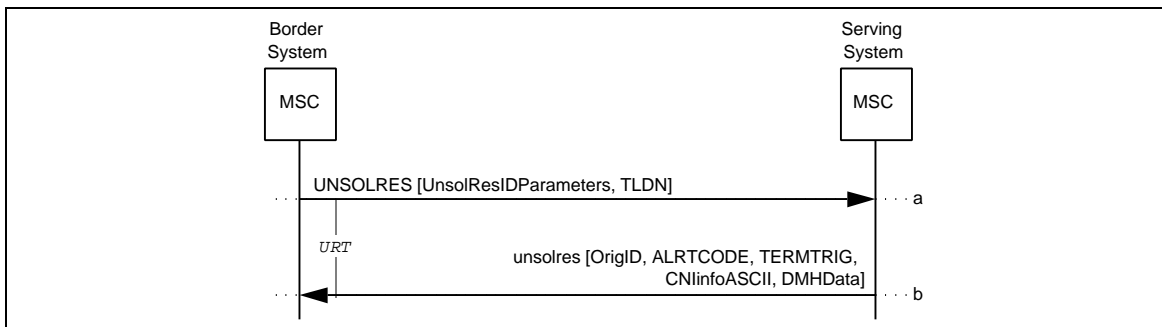

Figure 85 Successful UnsolicitedResponse

1
2
3
4
5
6
7
8
9
10
11
12
13
14
15
16
17
18
19
20
21
22
23
24
25
26
27
28
29
30
31
32
33
34
35
36
37
38
39
40
41
42
43
44
45
46
47
48
49
50
51
52
53
54
55
56
57
58
59
60

- a. An unsolicited or unexpected page response is received from an MS by a Border MSC. The Border MSC sends a UNSOLRES to its neighboring MSCs, including the Serving MSC.

Parameters	Usage	Type
UnsolResIDParameters:	Set of identification parameters in UNSOLRES:	
[BillingID]	Border MSC BillingID required for recording.	R
[MIN]	Served MS MIN.	R
[ESN]	Served MS ESN.	R
[ExtendedSystemMy-TypeCode]	Border MSC vendor identification.	O
[ExtendedMSCID]	Border MSC MSCID.	R
[PC_SSN]	Border MSC PC_SSN. Include if SS7 carriage services are used.	O
TLDN [DGTSDEST]	Destination digits for use in inter-MSC call routing.	R

- b. The Serving MSC stops paging the identified MS and forwards the information it has received to the Originating MSC. It also returns the Originating MSC information and call identification to the Border MSC in the `unsol res` so as to enable subsequent message exchanges between the originating and Border MSCs.

Parameters	Usage	Type
OrigID:	Originating MSC information:	
[BillingID]	Call ID for billing and redirection purposes.	R
[ExtendedSystemMy-TypeCode]	Originating MSC vendor identification.	O
[ExtendedMSCID]	Originating MSC MSCID.	R
[PC_SSN]	Originating MSC PC_SSN. Include if SS7 carriage services are used.	O
ALRTCODE	Type of alert signal to apply. Include if special alerting is to be applied to the MS.	O
TERMTRIG	Termination trigger points currently active for the subscriber. Include if applicable.	O
CNIinfoASCII:	CNI information including digits parameters in ASCII format. Include as applicable:	
[CallingPartyNumber-String1]	Calling number digits (network-provided), incl. presentation restriction information.	O
[CallingPartyNumber-String2]	Calling number digits (user-provided), incl. presentation restriction information.	O
[RedirectingNumber-String]	Redirecting number digits, incl. presentation restriction information.	O
[CallingPartySubaddress]	Calling number subaddress (user-provided).	O
[RedirectingSubaddress]	Redirecting number subaddress.	O
DMHData:	Data for <i>DMH</i> recording purposes:	
[DMH_AccountCode-Digits]	Include if applicable.	O
[DMH_AlternateBilling-	Include if applicable.	O

Digits]		
[DMH_BillingDigits]	Include if applicable.	O
[MobileDirectory-Number]	Include if applicable.	O

4.37.2 Unsuccessful UnsolicitedResponse with Return Result

This operation scenario describes an unsuccessful invocation of the UnsolicitedResponse operation.

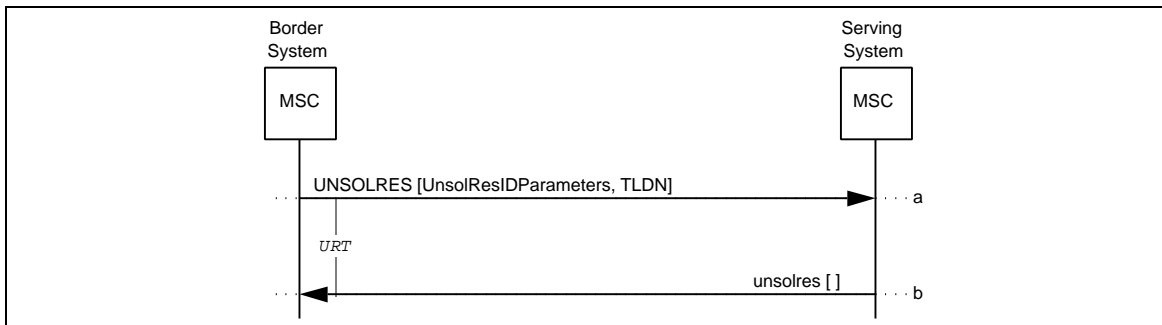

Figure 86 Unsuccessful UnsolicitedResponse with Return Result

- a. Same as Section 4.37.1, Step-a.
- b. The Serving MSC determines that the Border MSC is not appropriate in this case and returns as empty `unsol res`.

5 BASIC AUTOMATIC ROAMING SCENARIOS

This section depicts the interactions between network entities in various situations related to the support of basic automatic roaming functionality, i.e.:

- registration,
- deregistration,
- MS inactivity reporting,
- authentication,
- basic feature processing, and
- automatic roaming maintenance.

Please note that the scenarios in this section do not include a complete listing of operation parameters, either in the figures or in the accompanying text descriptions. Parameters are included where they are deemed necessary to improve the understanding of the scenario. For a complete description of the parameters associated with each operation, refer to *TIA/EIA-41* Chapter 5.

1
2
3
4
5
6
7
8
9
10
11
12
13
14
15
16
17
18
19
20
21
22
23
24
25
26
27
28
29
30
31
32
33
34
35
36
37
38
39
40
41
42
43
44
45
46
47
48
49
50
51
52
53
54
55
56
57
58
59
60

5.1 Registration

This section illustrates some typical MS registration scenarios, i.e.:

- Normal Registration.
- Multiple Registrations at the HLR.

5.1.1 Initial MS Registration in a New Serving System

This scenario describes the registration and validation process as an MS roams from one system to another.

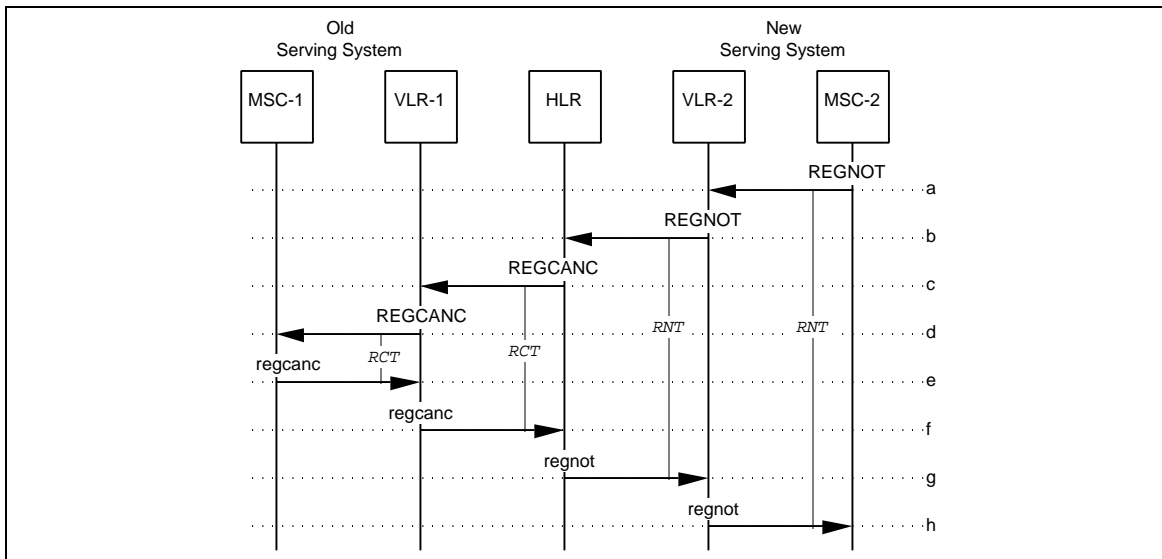

Figure 87 Initial MS Registration in a New Serving System

1
2
3
4
5
6
7
8
9
10
11
12
13
14
15
16
17
18
19
20
21
22
23
24
25
26
27
28
29
30
31
32
33
34
35
36
37
38
39
40
41
42
43
44
45
46
47
48
49
50
51
52
53
54
55
56
57
58
59
60

- a. After determining that a roaming MS is now within its service area, the new Serving MSC (MSC-2) sends a REGNOT to its VLR (VLR-2); MSC-2 may detect the MS's presence through autonomous registration, call origination, call termination (i.e., a page response following a call to the roamer port) or a service order.
- b. Since the MS is unknown to VLR-2, VLR-2 sends a REGNOT to the HLR associated with the MS. Note that the RegistrationNotification response from the VLR to the MSC is contingent upon the response received from the HLR.
- c. Since the MS was previously registered elsewhere, the HLR sends a REGCANC to the previously visited VLR (VLR-1). That VLR, upon receipt of the cancellation message, essentially removes all record of the MS from its memory.
- d. VLR-1 sends a REGCANC to the previously visited MSC (MSC-1). That MSC, upon receipt of the cancellation message, essentially removes all record of the MS from its memory.
- e. MSC-1 sends a regcanc to VLR-1.
- f. VLR-1 sends a regcanc to the HLR.
- g. The HLR sends a regnot to VLR-2.
- h. VLR-2 sends a regnot to MSC-2.

5.1.2 Multiple Registrations with Cancellation Denied at the VLR

This scenario describes the intersystem message flow resulting from an HLR detecting multiple registration accesses. In this scenario, it is assumed that the old serving system receives the MS with the best signal strength. The old serving system will then keep serving the MS.

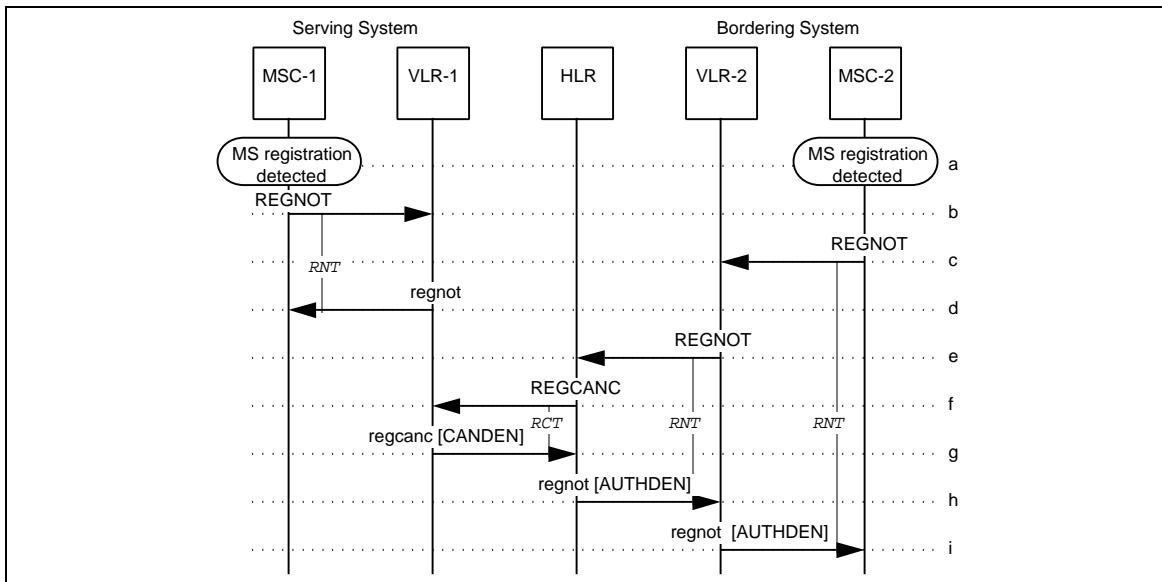

Figure 88 Multiple Registrations with Cancellation Denied at the VLR

- 1
2
3
4
5
6
7
8
9
10
11
12
13
14
15
16
17
18
19
20
21
22
23
24
25
26
27
28
29
30
31
32
33
34
35
36
37
38
39
40
41
42
43
44
45
46
47
48
49
50
51
52
53
- a. Both the Serving MSC (MSC-1) and a bordering MSC (MSC-2) detect a registration access from the MS.
 - b. MSC-1 sends a REGNOT to the Serving VLR (VLR-1).
 - c. MSC-2 sends a REGNOT to the bordering VLR (VLR-2).¹
 - d. Since the MS is already registered in this system, VLR-1 does not send a REGNOT to the HLR. However, it internally marks the registration time, and stores the signal strength value of the registration request. It then returns a regnot to MSC-1.
 - e. Since the MS is not already registered in this system, VLR-2 sends a REGNOT including ReceivedSignalQuality (RSIGQUAL), control channel identification (CCDATA) and System Access Data (SYSACCDATA) to the HLR associated to the subscriber.
 - f. The HLR will determine if a multiple access is taking place according to its internal algorithm. If no multiple access is taking place, the HLR will skip the best signal arbitration and perform the normal location updating procedure. Otherwise, the HLR performs signal strength arbitration and sends a REGCANC to VLR-1. It will include the access information of the best access it received (RSIGQUAL, CCDATA, SYSACCDATA).
 - g. Using the time of arrival of the REGCANC, VLR-1 determines if it received an access that matches the registration event. If it did not, it will accept the cancellation request and discard its record.

If it received a matching registration access, VLR-1 performs signal strength arbitration (see *TIA/EIA-41* Chapter 6 Annex F). VLR-1 determines that it received the best MS signal strength and sends a regcanc with an indication that it denies the cancellation request by including the CancellationDenied parameter (CANDEN) along with the access information (RSIGQUAL, CCDATA, SYSACCDATA) to the HLR.
 - h. The HLR returns a regnot to VLR-2 with an indication that it has rejected its registration notification by including the AuthorizationDenied (AUTHDEN) parameter set to a value of *Multiple Access*. It also includes the access information (RSIGQUAL, CCDATA, SYSACCDATA) for maintenance purposes.
 - i. VLR-2 forwards the regnot to MSC-2.

¹Step-c may occur before Step-b.

5.2 Deregistration

This section illustrates some typical deregistration scenarios, i.e.:

- MS Deregistered by the Serving MSC.
- MS Deregistered by the Serving VLR.

5.2.1 MS Deregistered by Serving MSC

This scenario describes the process by which an MS is deregistered by the Serving MSC.

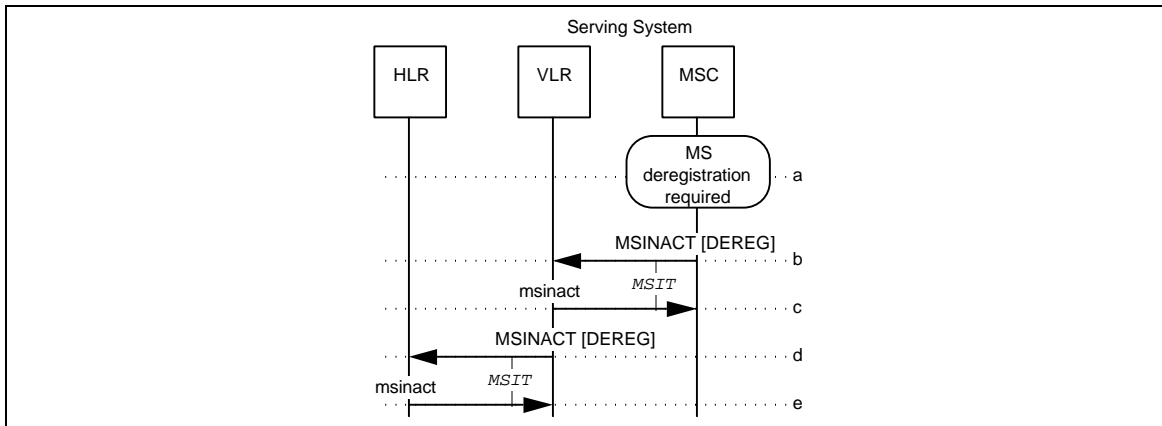

Figure 89 MS Deregistered by Serving MSC

- The Serving MSC determines that deregistration of a served MS is required; this may be due to receipt of an MS power-down indication, MS inactivity, or loss of radio contact.
- The Serving MSC sends an **MSI NACT**, including a **DeregistrationType** parameter, to its VLR. At this point, the MSC may choose to remove all record of the MS from its memory.
- The Serving VLR, upon receipt of the **MSI NACT** containing the **DeregistrationType** parameter, sends an **msi nact** to the Serving MSC and may choose to remove all record of the mobile from its memory.
- The Serving VLR may then send an **MSI NACT**, including a **DeregistrationType** parameter, to the HLR associated with the MS. (If this **MSINACT** is not sent, the VLR must be prepared to receive **RoutingRequest INVOKEs** from the HLR for this MS.)
- The HLR deregisters the MS (i.e., clears the pointer to the VLR) and sends an empty **msi nact** to the Serving VLR to acknowledge the operation.

5.2.2 MS Deregistered by Serving VLR

This scenario describes the process by which an MS is deregistered by the Serving VLR.

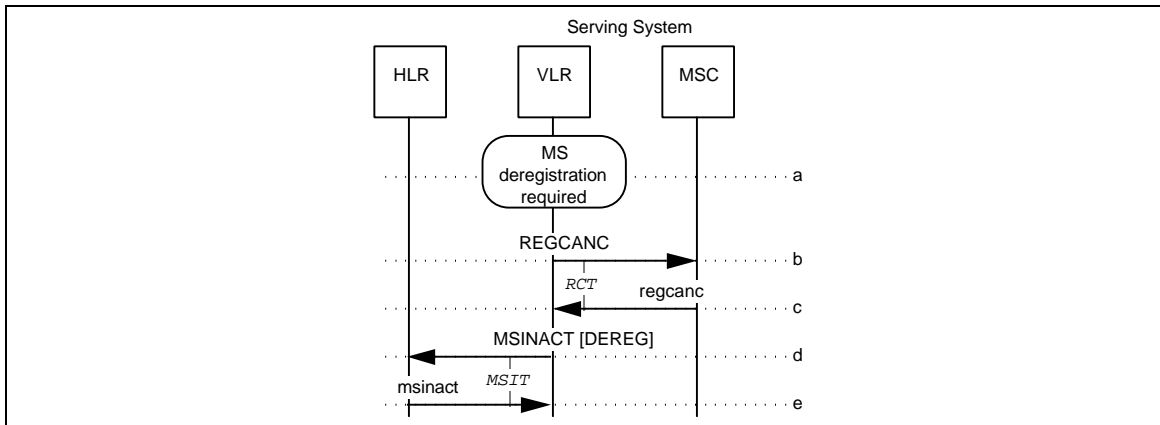

Figure 90 MS Deregistered by Serving VLR

- a. The Serving VLR determines that deregistration of a served MS is required; this may be based upon internal algorithms.
- b. The Serving VLR sends an `REGCANC` to the Serving MSC.
- c. The Serving MSC, upon receipt of the cancellation message, removes all record of the MS from its memory and sends a `regcanc` to the Serving VLR.
- d. The Serving VLR sends an `MSINACT`, including a `DeregistrationType` parameter, to the HLR. At this point, the VLR may choose to remove all record of the MS from its memory.
- e. The HLR sends an `msi nact` to the Serving VLR.

5.3 MS Inactivity Reporting

This section illustrates some typical MS inactivity scenarios, i.e.:

- Registered MS Declared Inactive by the Serving MSC.
- MS Declared Inactive by the Serving MSC at Registration.
- MS Declared Inactive by Serving VLR.
- MS Reported Inactive via the RoutingRequest Operation.

5.3.1 Registered MS Declared Inactive by Serving MSC

The following describes the process by which the Serving MSC declares an MS inactive after registration, but does not deregister the MS.

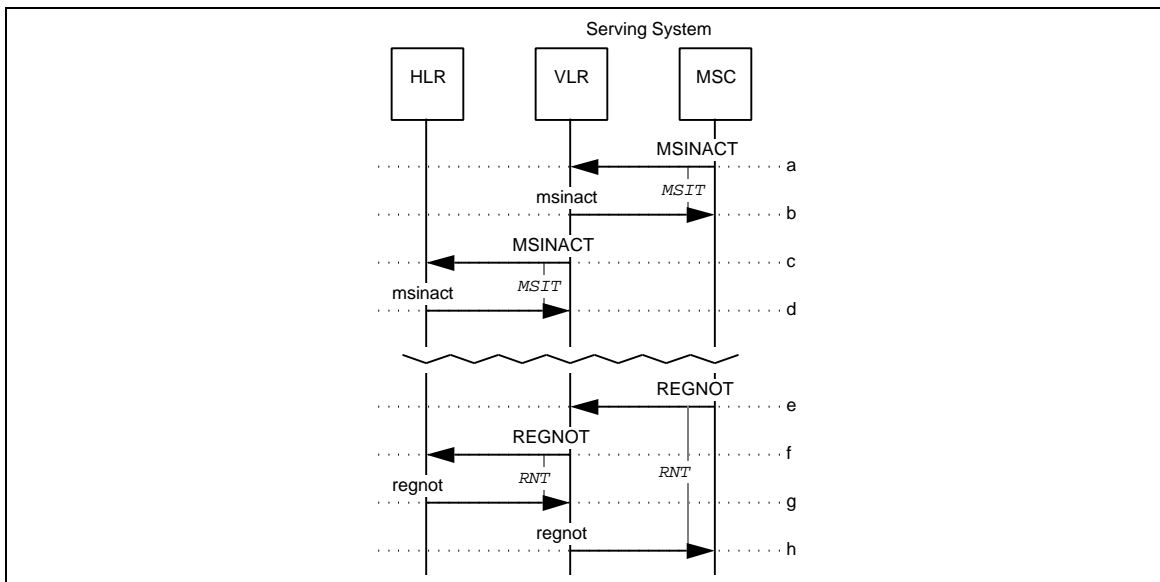

Figure 91 Registered MS Declared Inactive by Serving MSC

- After determining that a registered, roaming MS is no longer active, the Serving MSC sends an **MSINACT** to its VLR. At this point, the MSC either marks the MS as inactive in its internal data structures or removes all record of the MS from its memory.
- The VLR sends an **msinact** to the Serving MSC.
- The VLR in turn sends an **MSINACT** to the HLR associated with the MS. The VLR may choose to mark the MS as inactive in its internal structures (while maintaining the profile and validation information) or to remove all record of the MS from its memory. Note that a VLR may declare an MS inactive based upon internal algorithms that are not dependent on receiving an **MSINACT** from an MSC.
- The HLR sets the MS state to inactive and sends an **msinact** to the Serving VLR.

- e. At some future point in time, the MSC determines that the MS is active and available for call delivery within its serving area and sends a **REGNOT** to its VLR. Note that the reporting MSC may be different from the MSC that initially declared the MS inactive.
- f. The VLR then sends a **REGNOT** to the HLR associated with the MS; both the VLR and the HLR use the registration notification as an indication that the MS is now active and update their internal data structures accordingly.
- g. The HLR sends a **regnot** to the Serving VLR.
- h. The VLR sends a **regnot** to the Serving MSC.

5.3.2 MS Declared Inactive by Serving MSC at Registration

The following describes the process by which the Serving MSC declares an MS inactive at registration.

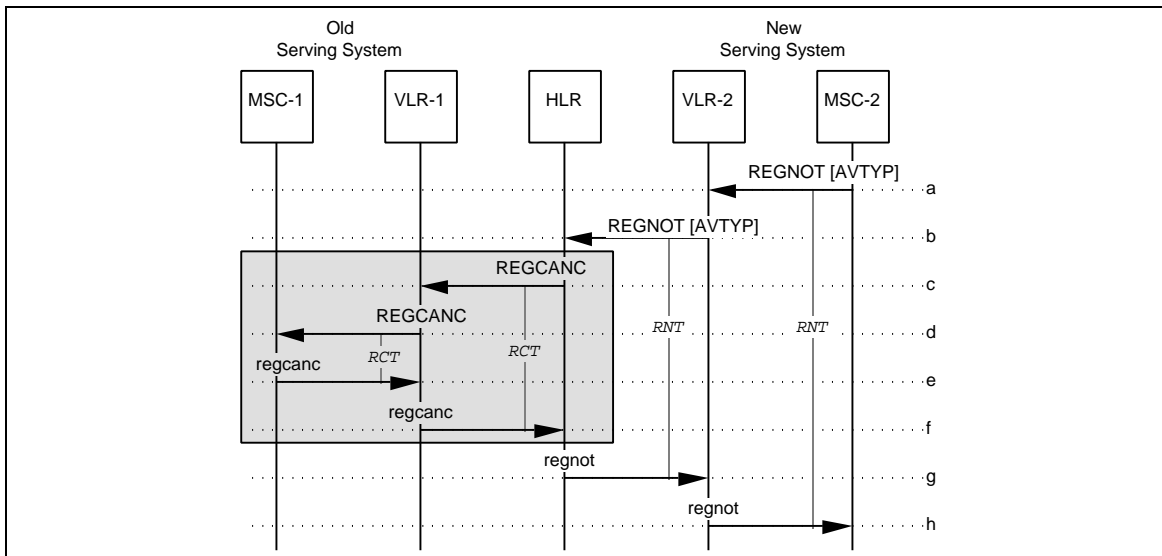

Figure 92 MS Declared Inactive by Serving MSC at Registration

- a. An MS may indicate that it may be unresponsive to paging for periods of time (e.g., slotted paging mode, sleep mode, or paging frame class) which may affect the ability of the mobile to receive calls for call delivery. The Serving MSC (MSC-2) registers the MS as inactive by sending a **REGNOT** to the associated VLR (VLR-2). MSC-2 retains knowledge of the presence of the MS and marks the MS as inactive in its internal data structures.
- b. VLR-2 receives the **REGNOT** and forwards it to the HLR associated with the MS.
- c. If the MS was previously registered elsewhere, the HLR sends a **REGCANC** to the previously visited VLR (VLR-1). That VLR, upon receipt of the cancellation message, essentially removes all record of the MS from its memory.

- 1
2
3 d. VLR-1 sends a REGCANC to the previously visited MSC (MSC-1). That MSC, upon
4 receipt of the cancellation message, essentially removes all record of the MS from its
5 memory.
6
7 e. MSC-1 sends a regcanc to VLR-1.
8
9 f. VLR-1 sends a regcanc to the HLR.
10
11 g. The HLR sends a regnot to VLR-2 to acknowledge the operation.
12
13 h. VLR-2 receives and forwards the regnot to MSC-2 to acknowledge the operation.

14 **5.3.3 MS Declared Inactive by Serving VLR**

16 For a description of the process by which the Serving VLR declares an MS inactive, see
17 Section 4.18.1.
18

19 **5.3.4 MS Reported Inactive via the RoutingRequest Operation**

21 For a description of the process by which an MS is reported inactive via the RoutingRequest
22 operation, see Section 4.29.3.
23
24
25
26
27
28
29
30
31
32
33
34
35
36
37
38
39
40
41
42
43
44
45
46
47
48
49
50
51
52
53
54
55
56
57
58
59
60

5.4 Authentication

This section depicts the interactions between network entities in the situations related to the support of Authentication, Signaling Message Encryption and Voice Privacy under automatic roaming conditions.

These scenarios are for illustrative purposes only.

Refer to Annex A.1 for a listing of assumptions which apply to this section.

Descriptions of authentication algorithms for RANDC verification, SSD management at the Authentication Center, and authentication response verification can be found in *TIA/EIA-41* Chapter 6- Annexes A, B, and C.

1
2
3
4
5
6
7
8
9
10
11
12
13
14
15
16
17
18
19
20
21
22
23
24
25
26
27
28
29
30
31
32
33
34
35
36
37
38
39
40
41
42
43
44
45
46
47
48
49
50
51
52
53
54
55
56
57
58
59
60

5.4.1 Initial Registration with Authentication

This scenario describes the intersystem message flow required to support authentication when an MS initially registers in a visited system.

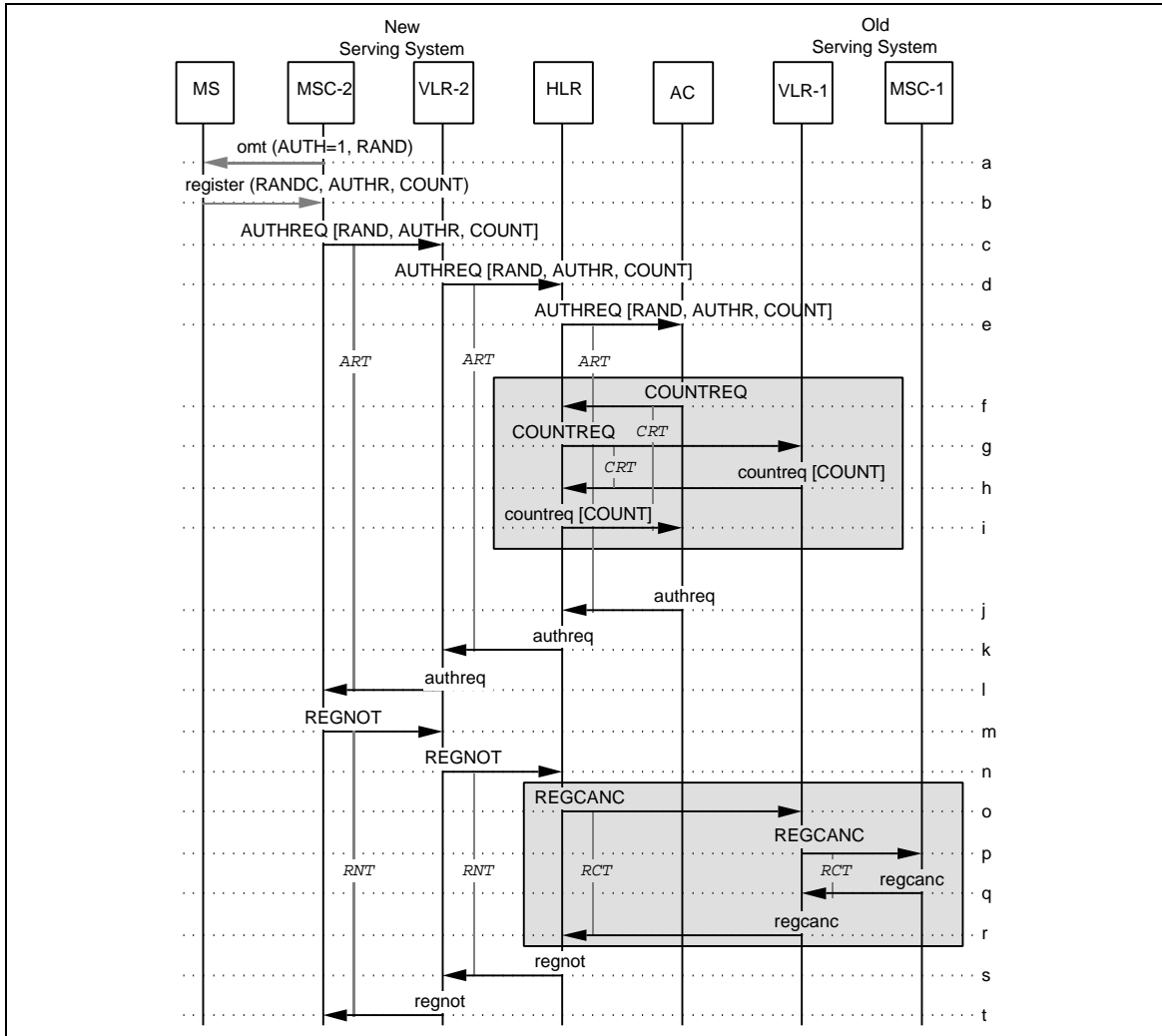

Figure 93 Initial Registration with Authentication

- 1
2
3
4
5
6
7
8
- a. The MS determines from the Overhead Message Train (OMT) that a new serving system has been entered and that authentication is required on all system accesses (AUTH=1). The Random Number (RAND) to be used for authentication may also be obtained by the MS at this time. If it is not, a zero value is used by the MS as prescribed by TR-45 Authentication.

9
10
11

The MS executes CAVE using the SSD-A currently stored, ESN, MIN1 and the RAND value to produce a registration Authentication Result (AUTHR).

- 12
13
14
15
16
17
18
19
20
21
22
23
24
25
- b. The MS registers at the new Serving MSC (MSC-2), providing its MIN, ESN, AUTHR, CallHistoryCount (COUNT), and RANDC derived from the RAND used to compute AUTHR.
- c. MSC-2 verifies RANDC supplied by the MS and sends the appropriate value of RAND in an AUTHREQ to the new Serving VLR (VLR-2).
- d. VLR-2 forwards the AUTHREQ to the HLR associated with the MIN.
- e. The HLR forwards the AUTHREQ to its AC.
- f-i. If SSD is presently shared with another system, the AC shall perform validation of the MS as described in Section 5.4.8 (Authentication with sharing of SSD) and go on to Step-j below.

26
27
28
29

Otherwise, the AC verifies the MIN and ESN reported by the MS. The AC then executes CAVE using the SSD-A currently stored, ESN, MIN1 and the RAND value to produce a registration Authentication Result (AUTHR).

30
31

The AC verifies that the AUTHR received from the MS matches its CAVE results.

32
33

The AC then verifies that the COUNT received from the MS is consistent with the value currently stored at the AC.

- 34
35
36
37
38
39
40
41
42
43
44
45
46
47
48
49
50
51
52
53
54
55
56
57
58
59
60
- j. The AC sends an **authreq** to the HLR. The **authreq** may include SSD and directives to issue a Unique Challenge, to update the MS SSD or to update the MS COUNT according to AC/HLR local administrative practices. These update procedures are described in Sections 5.4.6, 5.4.7, and 5.4.9. Alternatively, the **authreq** may include DenyAccess.
- k. The HLR forwards the **authreq** to VLR-2.
- l. VLR-2 forwards the **authreq** to the MSC-2.
- m. Following successful authentication of the MS, MSC-2 sends a **REGNOT** to VLR-2.
- n. VLR-2 forwards the **REGNOT** to the HLR.
- o. If the MS was previously registered in another system, the HLR sends a **REGCANC** to the old Serving VLR (VLR-1).
- p. VLR-1 forwards the **REGCANC** to the old Serving MSC (MSC-1).
- q. MSC-1 returns a **regcanc** to VLR-1.
- r. VLR-1 returns a **regcanc** to the HLR.
- s. The HLR records the new location of the MS in its local memory and responds to the **REGNOT** with a **regnot** that includes the information requested by VLR-2.

t. VLR-2 forwards the regnot to MSC-2.

5.4.2 Origination with Authentication

This scenario describes the intersystem message flow required to support authentication when the access in the visited system is a call origination.

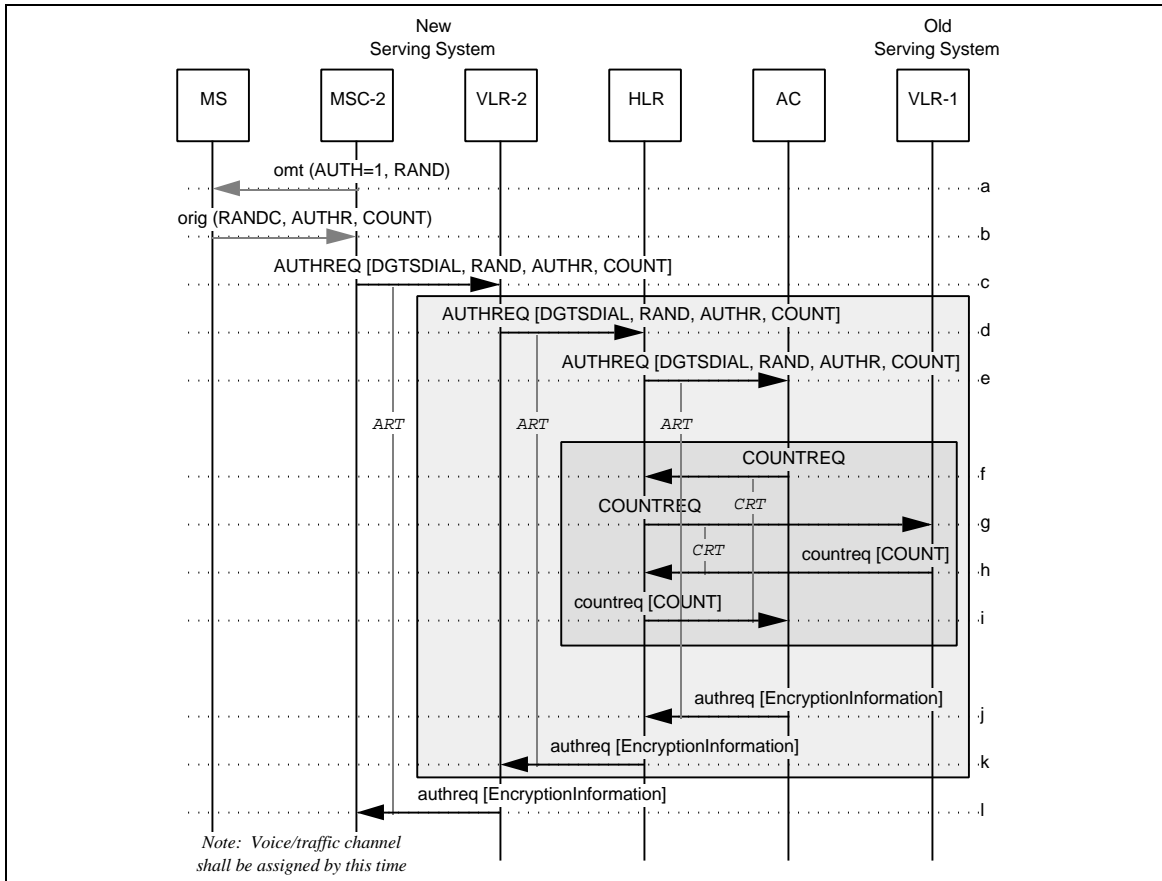

Figure 94 Origination with Authentication

1
2
3
4
5
6
7
8
9
10
11
12
13
14
15
16
17
18
19
20
21
22
23
24
25
26
27
28
29
30
31
32
33
34
35
36
37
38
39
40
41
42
43
44
45
46
47
48
49
50
51
52
53
54
55
56
57
58
59
60

- a. The MS determines from the Overhead Message Train (OMT) that authentication is required on all system accesses (AUTH=1). The Random Number to be used for authentication (RAND) may also be obtained by the MS at this time. If it is not, a zero value is used by the MS, as prescribed by TR-45 authentication.
- b. The MS sends an origination message to the new Serving MSC (MSC-2), providing the dialed digits, its MIN, ESN, Authentication Result (AUTHR), CallHistoryCount (COUNT) and the RANDC from the RAND used to compute AUTHR.
- c. MSC-2 verifies RANDC supplied by the MS and sends the dialed digits along with the appropriate value of RAND in an AUTHREQ to the new Serving VLR (VLR-2).
- d. If SSD is presently shared with VLR-2, the VLR shall perform validation of the MS and go on to Step-l; otherwise, VLR-2 forwards the AUTHREQ to the HLR associated with the MIN.
- e. The HLR forwards the AUTHREQ to its AC.
- f-i. If SSD is presently shared with another system, the AC shall retrieve the current COUNT value and perform validation of the MS as described in Section 5.4.8 (Authentication with Shared SSD) and go on to Step-j below.

Otherwise, the AC verifies the MIN and ESN reported by the MS and then executes CAVE using the SSD-A and ESN currently associated with the MS along with the value of RAND and the dialed digits provided by the serving system to produce an origination Authentication Response (AUTHR).

The AC verifies that the AUTHR received from the MS matches its CAVE results.

The AC then verifies that the COUNT received from the MS is consistent with the value currently stored at the AC.

- j. The AC sends an **authreq** to the HLR. The **authreq** shall include the SMEKEY and VPMASK associated with this system access. Currently the AC has no way of determining whether the MS has subscribed to Voice Privacy. Therefore, the VPMASK is generated and passed by the AC on all system accesses which are origination or page response.

EncryptionInformation:		
[CDMAPLCM]	CDMAPPrivateLongCodeMask. Include if generated by the AC.	O
[SMEKEY]	SignalingMessageEncryptionKey. Include if generated by the AC.	O
[VPMASK]	VoicePrivacyMask. Include if generated by the AC.	O

Note: The **authreq** may also include SSD and directives to issue a Unique Challenge, to update the MS SSD, or to update the MS COUNT according to AC local administrative practices. These update procedures are described in Sections 5.4.6, 5.4.7, and 5.4.9. Alternatively, the **authreq** may include DenyAccess.

- 1
2
3 k. The HLR forwards the **authreq** to VLR-2.

4 5 EncryptionInformation: 6 [CDMAPLCM]	7 CDMAPrivateLongCodeMask. Include if 8 available and MS is subscribed to Voice 9 Privacy.	10 O
11 [SMEKEY]	12 SignalingMessageEncryptionKey. Include if 13 available.	14 O
15 [VPMASK]	16 VoicePrivacyMask. Include if available and MS 17 is subscribed to Voice Privacy.	18 O

- 19
20
21
22
23
24
25
26
27
28
29
30
31
32
33
34
35
36
37
38
39
40
41
42
43
44
45
46
47
48
49
50
51
52
53
54
55
56
57
58
59
60
l. VLR-2 returns an **authreq** to MSC-2.

Following successful authentication of the MS, MSC-2 assigns the MS to an analog voice channel or a digital traffic channel or retains the existing assignment.

5.4.3 Termination with Authentication

This scenario describes the intersystem message flow required to support authentication when a call is terminated to a visiting MS in the serving system.

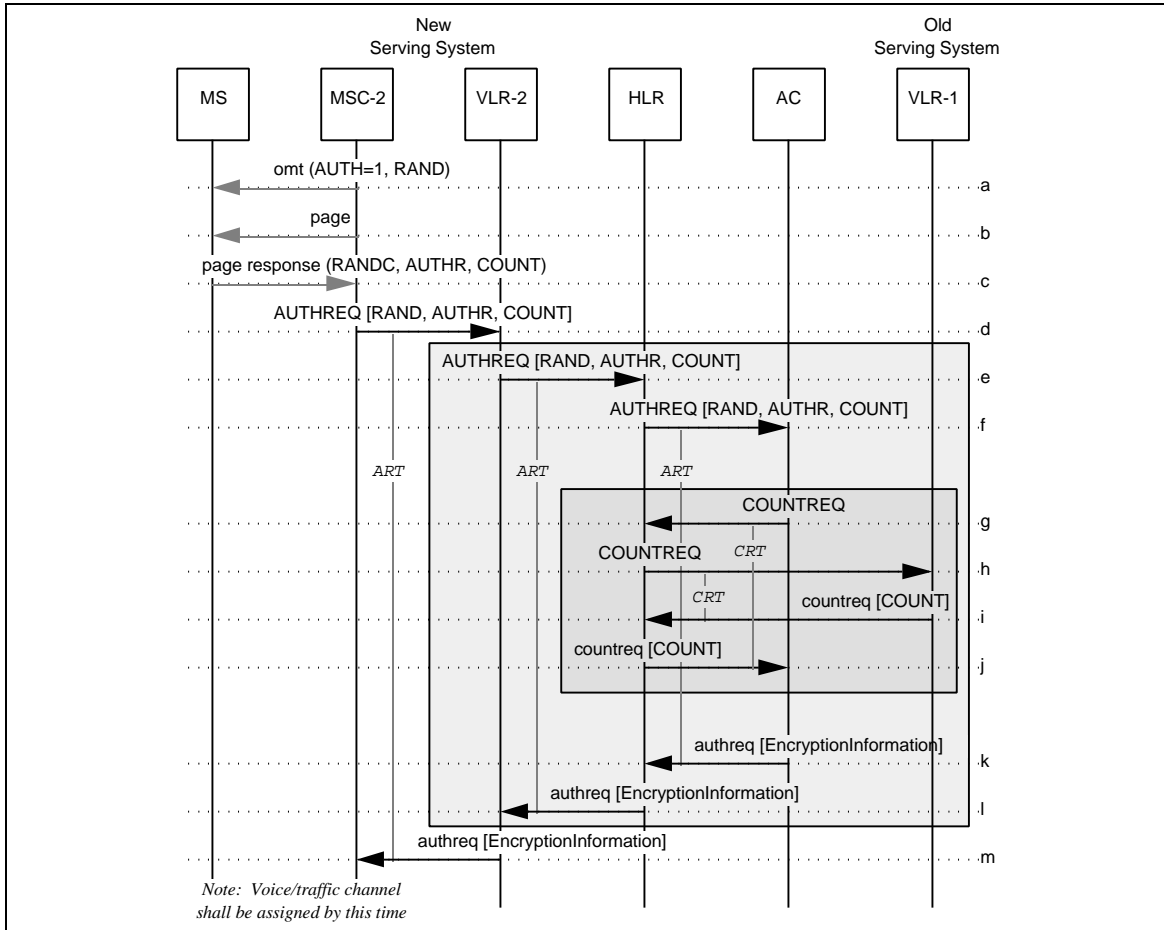

Figure 95 Termination with Authentication

1
2
3
4
5
6
7
8
9
10
11
12
13
14
15
16
17
18
19
20
21
22
23
24
25
26
27
28
29
30
31
32
33
34
35
36
37
38
39
40
41
42
43
44
45
46
47
48
49
50
51
52
53
54
55
56
57
58
59
60

- a. The MS determines from the Overhead Message Train (OMT) that authentication is required on all system accesses (AUTH=1). The Random Number to be used for authentication (RAND) may also be obtained by the MS at this time; if it is not, a zero value is used by the MS, as prescribed by TR-45 authentication.
- b. The MS recognizes a page message with its MIN and executes CAVE using the SSD-A currently stored, ESN, MIN1, and the RAND value to produce a termination Authentication Result (AUTHR).
- c. The MS sends a page response message to the new Serving MSC (MSC-2) providing its MIN, ESN, Authentication Result (AUTHR), CallHistoryCount (COUNT) and the RANDC from the RAND used to compute AUTHR.
- d. MSC-2 verifies RANDC supplied by the MS and sends the appropriate value of RAND in an AUTHREQ to the new Serving VLR (VLR-2).
- e. If SSD is presently shared with VLR-2, the VLR shall perform validation of the MS and go on to Step-m; otherwise, VLR-2 forwards the AUTHREQ to the HLR associated with the MIN.
- f. The HLR forwards the AUTHREQ to its AC.
- g-j. If SSD is presently shared with another system, the AC shall retrieve the current COUNT value and perform validation of the MS as described in Section 5.4.8 (Authentication with Shared SSD) and go on to Step-k below.

Otherwise, the AC verifies the MIN and ESN reported by the MS. Then the AC executes CAVE using the SSD-A currently stored, ESN, and MIN1 associated with the MS along with the value of RAND provided by the serving system to produce a termination Authentication Response (AUTHR).

The AC verifies that the AUTHR received from the MS matches its CAVE results.

The AC then verifies that the COUNT received from the MS is consistent with the value currently stored at the AC.

- k. The AC sends an **authreq** to the HLR. The **authreq** shall include the SMEKEY and VPMASK associated with this system access.

EncryptionInformation:		
[CDMAPLCM]	CDMAPrivateLongCodeMask. Include if generated by the AC.	O
[SMEKEY]	SignalingMessageEncryptionKey. Include if generated by the AC.	O
[VPMASK]	VoicePrivacyMask. Include if generated by the AC.	O

Note: The **authreq** may also include directives to issue a Unique Challenge, to update the MS SSD, or to update the MS COUNT according to AC local administrative practices. These update procedures are described in Sections 5.4.6, 5.4.7, and 5.4.9. Alternatively, the **authreq** may include DenyAccess.

- 1
2
3
4
5
6
7
8
9
10
11
12
13
14
15
16
17
18
19
20
21
22
23
24
25
26
27
28
29
30
31
32
33
34
35
36
37
38
39
40
41
42
43
44
45
46
47
48
49
50
51
52
53
54
55
56
57
58
59
60
- l. The HLR forwards the **authreq** to VLR-2.

EncryptionInformation:		
[CDMAPLCM]	CDMAPrivateLongCodeMask. Include if available and MS is subscribed to Voice Privacy.	O
[SMEKEY]	SignalingMessageEncryptionKey. Include if available.	O
[VPMASK]	VoicePrivacyMask. Include if available and MS is subscribed to Voice Privacy.	O

- m. VLR-2 returns an **authreq** to MSC-2.

Following successful authentication of the MS, MSC-2 assigns the MS to an analog voice channel or a digital traffic channel or retains the existing assignment.

5.4.4 Authentication on Voice Channel Only

This scenario describes the intersystem message flow required for systems that support authentication only on the voice or traffic channel.

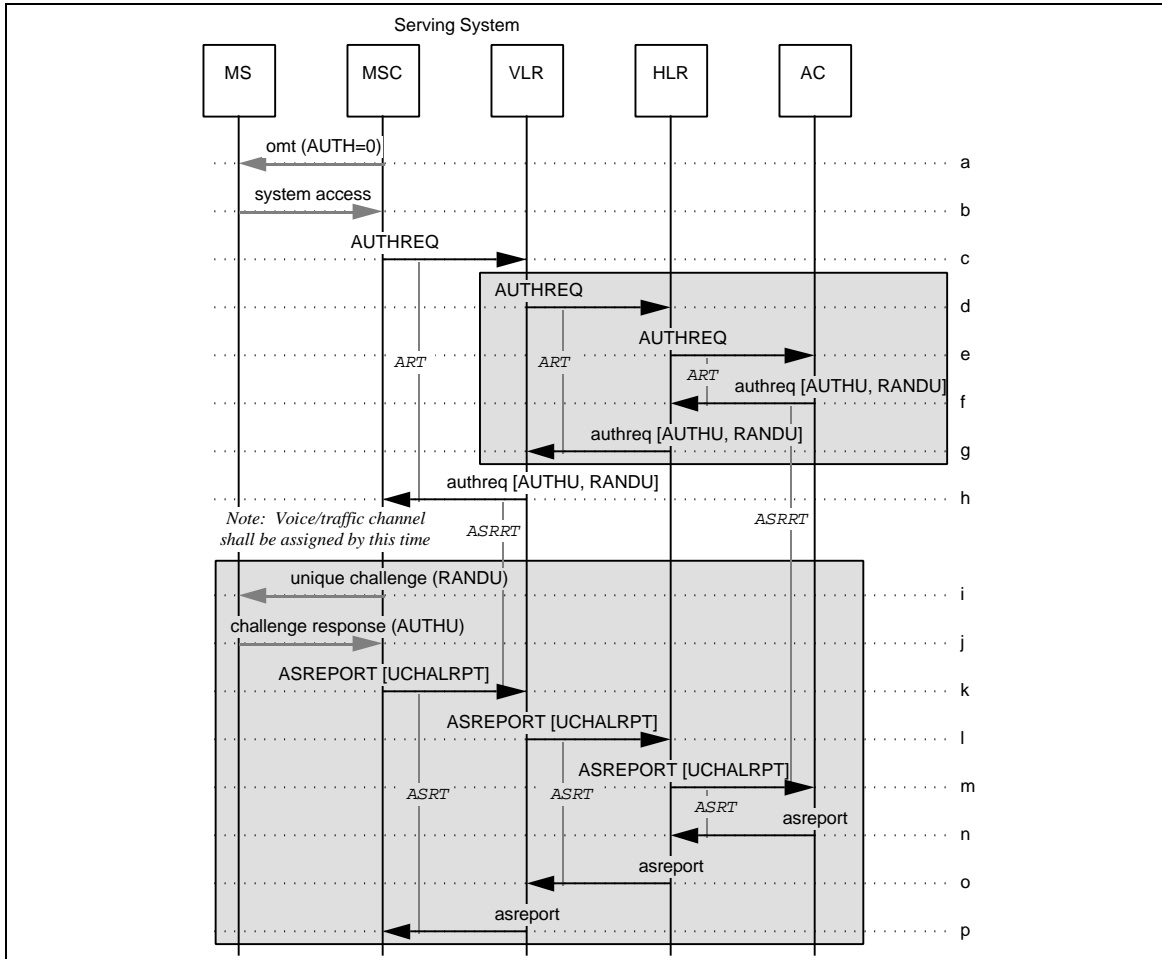

Figure 96 Authentication on Voice Channel

- The MS determines from the Overhead Message Train (OMT) that authentication is not required on system accesses (AUTH=0).
- The MS sends a system access message (registration, origination or page response) to the Serving MSC, providing its MIN and ESN only.
- The Serving MSC sends an AUTHREQ to the Serving VLR with the SystemAccessType set to Unspecified.
- If SSD is shared with the current serving system, then the VLR shall generate the RANDU locally, calculate AUTHU by executing CAVE, and proceed to Step h; otherwise, the VLR forwards the AUTHREQ to the HLR associated with the MIN.
- The HLR forwards the AUTHREQ to its AC.

- 1
2
3 f. The AC verifies the MIN and ESN reported by the MS. The AC chooses a Unique
4 Random Variable (RANDU) and executes CAVE using the SSD-A currently stored,
5 ESN, MIN1 and MIN2 associated with the MS to produce a Unique Authentication
6 Response (AUTHU).

7
8 The AC sends an **authreq** to the HLR including RANDU and the expected AUTHU
9 result.

- 10 g. The HLR forwards the **authreq** to the Serving VLR.
11
12 h. The Serving VLR sends an **authreq** to the Serving MSC, containing the values of
13 AUTHU and RANDU received in the **authreq** from the HLR (if SSD is not shared),
14 or the values calculated locally (if SSD is shared).
15

16 The Serving MSC assigns the MS to an analog voice channel or a digital traffic
17 channel. Optionally (especially if the system access is a registration), the Unique
18 Challenge messages may be exchanged over the control channel, before assignment of
19 a voice or traffic channel, as described in the following steps.
20

- 21 i. The Serving MSC sends a Unique Challenge order to the MS using the RANDU
22 provided in the **authreq**.
23
24 j. The MS executes CAVE using RANDU and the SSD-A currently stored, ESN, MIN1
25 and MIN2 to produce an Authentication Result (AUTHU) which is then sent to the
26 Serving MSC.

27 The Serving MSC compares the value of AUTHU provided in the **authreq** with that
28 received from the MS.

- 29
30 k. The Serving MSC sends an **ASREPORT** to the Serving VLR indicating success or
31 failure of the unique challenge.
32
33 l. If SSD is not shared, the VLR shall forward the **ASREPORT** to the HLR. If SSD is
34 shared and the Unique Challenge was successful, the VLR proceeds to Step-p. If
35 SSD is shared and the Unique Challenge failed, the VLR shall send an **AFREPORT** to
36 the HLR. For this scenario, we assume that SSD is not shared.
37

- 38 m. The HLR forwards the **ASREPORT** to its AC.
39
40 n. The AC responds with an **asreport** that may include SSD and directives to deny
41 access, to update SSD, or update COUNT according to the AC local administrative
42 practices (see Sections 5.4.6 and 5.4.7).
43
44 o. The HLR forwards the **asreport** to the Serving VLR.
45
46 p. The Serving VLR sends an **asreport** to the Serving MSC.
47
48
49
50
51
52
53
54
55
56
57
58
59
60

5.4.5 Authentication on Flash Request

This scenario describes the intersystem message flow required for authentication following a flash request by the MS.¹

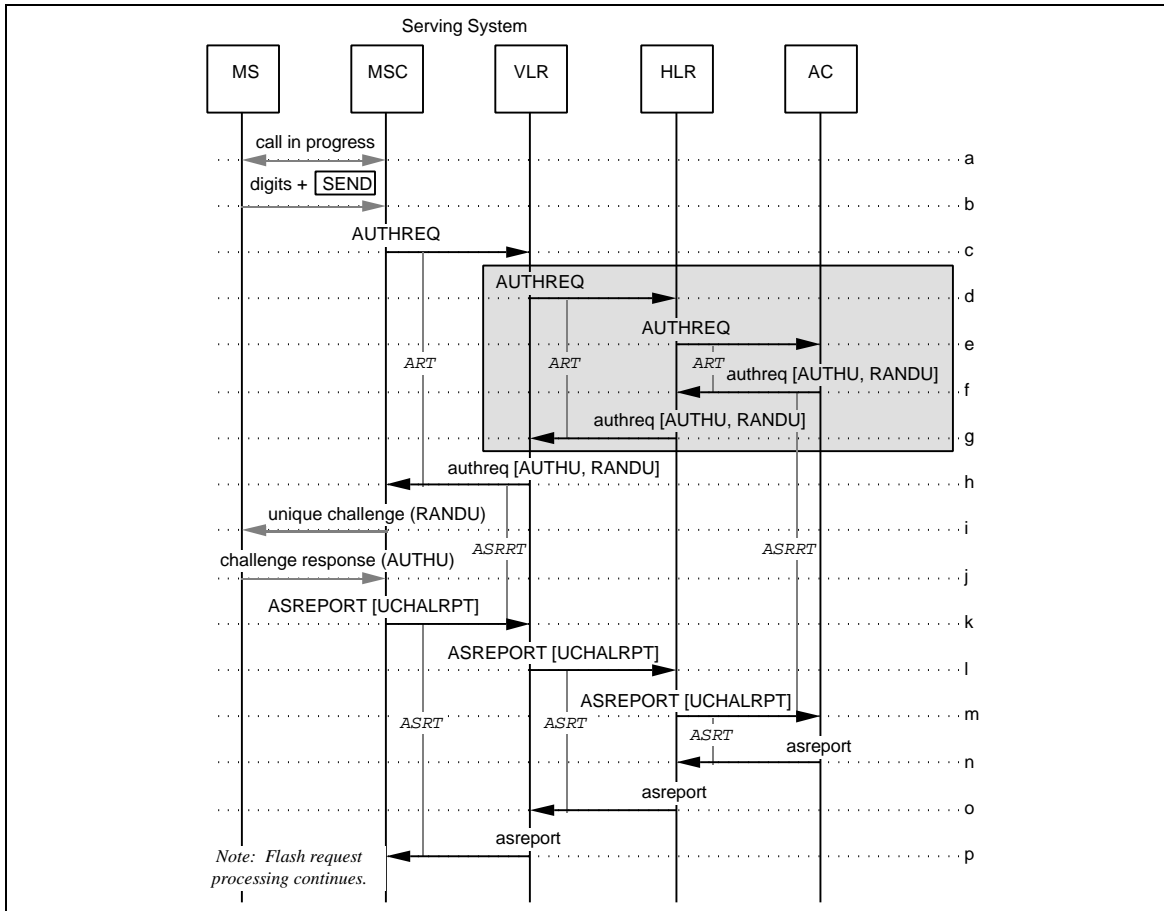

Figure 97 Authentication on Flash Request

¹This procedure, which guards against hijacking of the voice/traffic channel, may not be necessary if Signalling Message Encryption is being used between the MS and Serving MSC.

- 1
2
3
4
5
6
7
8
9
10
11
12
13
14
15
16
17
18
19
20
21
22
23
24
25
26
27
28
29
30
31
32
33
34
35
36
37
38
39
40
41
42
43
44
45
46
47
48
49
50
51
52
53
54
55
56
57
58
59
60
- a. A call is established on the voice/digital traffic channel, as shown in Sections 5.4.2 and 5.4.3.
 - b. The MS sends a flash request (with digits) to the Serving MSC, requesting a second (three party) call to be established.
 - c. The Serving MSC sends an AUTHREQ to the Serving VLR with the SystemAccessType set to FlashRequest'.
 - d. If SSD is shared with the current serving system, then the VLR shall generate the RANDU locally, calculate AUTHU by executing CAVE, and proceed to Step-h; otherwise, the VLR forwards the AUTHREQ to the HLR associated with the MIN.
 - e. The HLR forwards the AUTHREQ to its AC.
 - f. The AC verifies the MIN and ESN reported by the MS. The AC chooses a Unique Random Variable (RANDU) and executes CAVE using the SSD-A currently stored, ESN, MIN1 and MIN2 associated with the MS to produce a Unique Authentication Response (AUTHU).
The AC sends an authreq to the HLR including RANDU and the expected AUTHU result.
 - g. The HLR forwards the authreq to the Serving VLR.
 - h. The Serving VLR sends an authreq to the Serving MSC, containing the values of AUTHU and RANDU received in the authreq from the HLR (if SSD is not shared), or the values calculated locally (if SSD is shared).
 - i. The Serving MSC sends a Unique Challenge order to the MS using the RANDU provided in the authreq.
 - j. The MS executes CAVE using RANDU and the SSD-A currently stored, ESN, MIN1 and MIN2 to produce an Authentication Result (AUTHU) which is then sent to the Serving MSC.
The Serving MSC compares the value of AUTHU provided in the authreq with that received from the MS.
 - k. The Serving MSC sends an ASREPORT to the Serving VLR indicating success or failure of the unique challenge.
 - l. If SSD is not shared, the VLR shall forward the ASREPORT to the HLR. If SSD is shared and the Unique Challenge was successful, the VLR proceeds to Step-p. If SSD is shared and the Unique Challenge failed, the VLR shall send an AFREPORT to the HLR. For this scenario, we assume that SSD is not shared.
 - m. The HLR forwards the ASREPORT to its AC.
 - n. The AC responds with an asreport that may include SSD and directives to deny access, to update SSD, or update COUNT according to the AC local administrative practices (see Sections 5.4.6 and 5.4.7).
 - o. The HLR forwards the asreport to the Serving VLR.
 - p. The Serving VLR sends an asreport to the Serving MSC.

5.4.6 SSD Update When SSD is Not Shared

This scenario describes the intersystem message flow required to support SSD updating of a visiting MS when the SSD is not provided to the serving system for the SSD Update.

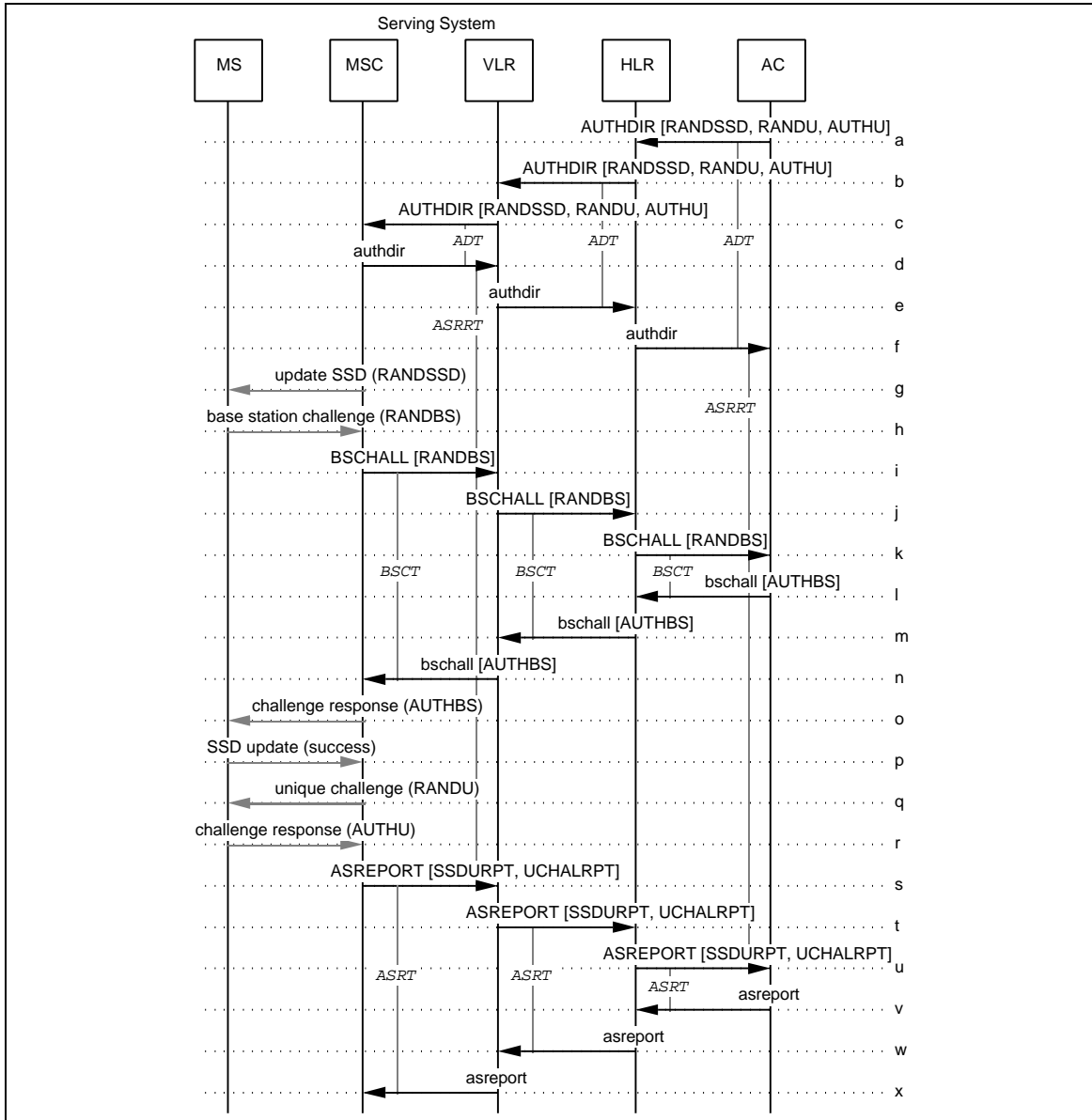

Figure 98 SSD Update When SSD is Not Shared

- 1
2
3
4
5
6
7
- a. The AC determines that the Shared Secret Data (SSD) in the MS must be updated. This may be the result of administrative procedures at the AC, expiration of an authentication time interval at the AC, or the report of a security violation from a visited system.

8
9
10
11
12

CAVE is executed at the AC to produce a new value of the SSD using the private A-key of the MS, ESN and a Random Number (RANDSSD) generated by the AC. Note that the AC must retain both the old and new values of the SSD until informed by the VLR of the outcome of the updating procedure.

13
14
15
16

The AC chooses a Unique Random Variable (RANDU) and executes CAVE using the new SSD-A, ESN, MIN1, and MIN2 associated with the MS to produce an Authentication Response for Unique Challenge (AUTHU).

17
18

An AUTHDI R is sent from the AC to the HLR associated with the MS.

- 19
20
21
22
23
24
25
26
27
28
29
30
31
32
33
34
35
36
37
38
39
40
41
42
43
44
45
46
47
48
49
50
- b. The HLR forwards the AUTHDI R to the current Serving VLR.²
- c. The Serving VLR forwards the AUTHDI R to the Serving MSC and deletes the current SSD if SSD is shared.
- d. The Serving MSC returns an empty `authdi r` to the Serving VLR to indicate that the directive has been accepted.
- e. The Serving VLR forwards the `authdi r` to the HLR.
- f. The HLR forwards the `authdi r` to the AC.
- g. The Serving MSC sends an SSD Update order to the MS using the value of RANDSSD provided by the AC. The message may be sent over the control channel or over a voice or traffic channel.
- h. The MS executes CAVE to produce a new value of SSD using the value of RANDSSD provided in the SSD Update order, ESN and A-key.
- The MS selects a Random Number (RANDBS) and sends a Base Station Challenge order to the Serving MSC including the value of RANDBS. The MS then executes CAVE to produce an Authentication Result (AUTHBS) using the new value of SSD-A, ESN, MIN1 and the Random Number (RANDBS).
- i. The Serving MSC sends a BSCHALL to the Serving VLR to request a response to the Base Station Challenge Order received from the MS.
- j. The Serving VLR forwards the BSCHALL to the HLR.
- k. The HLR forwards the BSCHALL to the AC.
- l. The AC executes CAVE to produce an Authentication Result (AUTHBS) using the new value of SSD-A, ESN, MIN1 for the MS and the Random Number (RANDBS)

51
52
53
54
55
56
57
58
59
60

²SSD updating may also be directed through an `authreq` (or `asreport` or `afreport`) as shown in Sections 5.4.1, 5.4.2, and 5.4.3. Procedures at the visited system are the same regardless of the message used to communicate the information from the AC to the VLR.

1
2
3
4
5
6
7
8
9
10
11
12
13
14
15
16
17
18
19
20
21
22
23
24
25
26
27
28
29
30
31
32
33
34
35
36
37
38
39
40
41
42
43
44
45
46
47
48
49
50
51
52
53
54
55
56
57
58
59
60

provided in the **BSCHALL**. The **AUTHBS** value is returned to the HLR in the **bschal I**.

- m. The HLR forwards the **bschal I** to the Serving VLR.
- n. The Serving VLR forwards the **bschal I** to the Serving MSC.
- o. The Serving MSC passes the AC's computed value of **AUTHBS** to the MS in a Base Station Challenge response message.
- p. If the **AUTHBS** result provided by the AC matches the value computed by the MS, the MS stores the new **SSD** value for use in future executions of **CAVE** and sends an **SSD Update Confirmation** message to the Serving MSC.
- q. The Serving MSC sends a Unique Challenge order to the MS using the **RANDU** provided in the **AUTHDI R** (Step-c).
- r. The MS executes **CAVE** using **RANDU** and the **SSD-A** currently stored, **ESN**, **MIN1**, and **MIN2** to produce an Authentication Response for Unique Challenge (**AUTHU**) which is then sent to the Serving MSC.

The Serving MSC compares the value of **AUTHU** provided by the AC in the **AUTHDI R** with that received from the MS.
- s. The Serving MSC sends an **ASREPORT** to the Serving VLR indicating the success or failure of the **SSD Update** and the Unique Challenge.
- t. The Serving VLR forwards the **ASREPORT** to the HLR.
- u. The HLR forwards the **ASREPORT** to the AC.
- v. The AC stores the new **SSD** value for use in future executions of **CAVE** for the MS if the **SSD Update** was successful. The AC sends an **asreport** to the HLR indicating that service is to be provided to the MS.
- w. The HLR forwards the **asreport** to the Serving VLR.
- x. The Serving VLR forwards the **asreport** to the Serving MSC.

5.4.7 AC Initiated CallHistoryCount Update with SSD Not Shared

This scenario describes the intersystem message flow required to support CallHistoryCount (COUNT) updating of an MS in a visited system. If SSD is shared, the VLR can independently initiate the AuthenticationDirective to update the count.

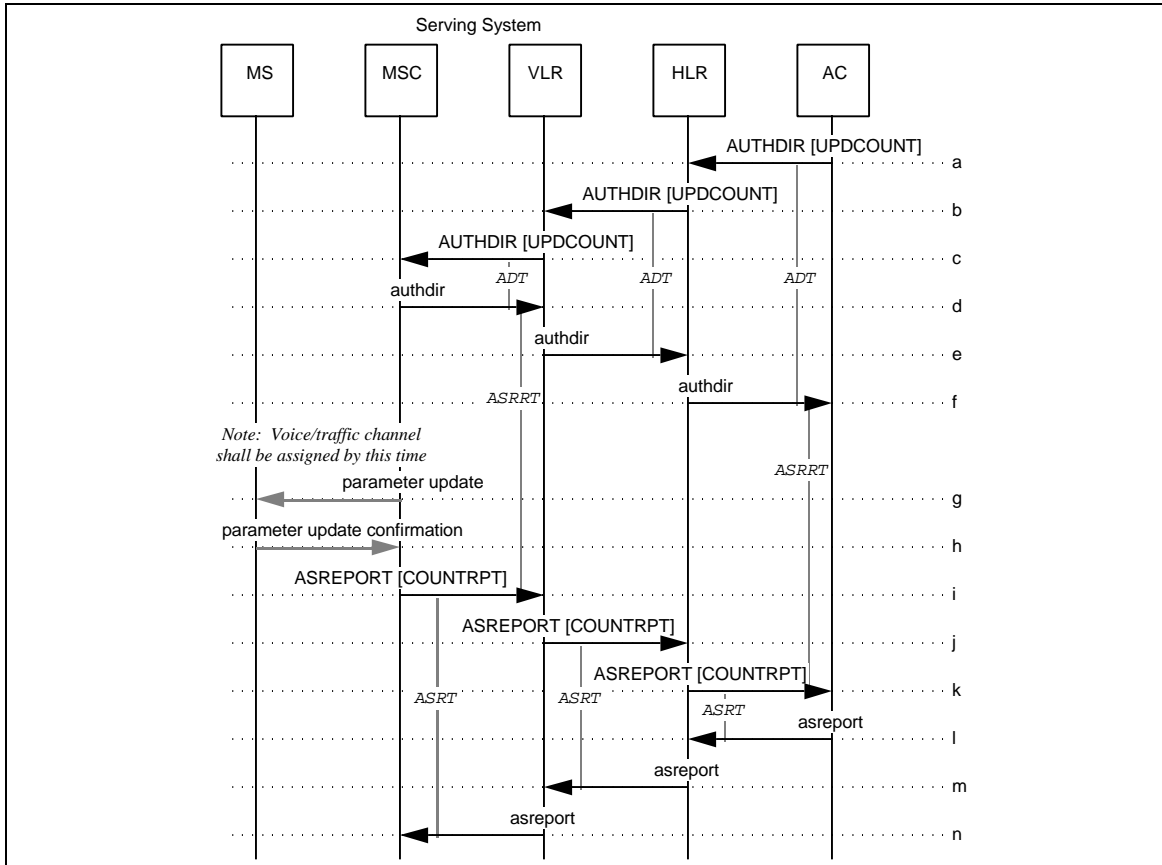

Figure 99 AC Initiated CallHistoryCount Update with SSD Not Shared

- 1
2
3
4
5
6
7
8
9
10
11
12
13
14
15
16
17
18
19
20
21
22
23
24
25
26
27
28
29
30
31
32
33
34
35
36
37
38
39
40
41
42
43
44
45
46
47
48
49
50
51
- a. The AC determines that the CallHistoryCount (COUNT) in the MS must be updated. This may be the result of administrative procedures at the AC, expiration of an authentication time interval at the AC, or the report of a security violation from a visited system.
An AUTHDI R is sent from the AC to the HLR associated with the MS.
 - b. The HLR forwards the AUTHDI R to the current Serving VLR.³
 - c. The current Serving VLR forwards the AUTHDI R to the current Serving MSC.
 - d. The Serving MSC returns an empty `authdi r` to the Serving VLR to indicate that the directive has been accepted.
 - e. The Serving VLR forwards the `authdi r` to the HLR.
 - f. The HLR forwards the `authdi r` to the AC.
 - g. The Serving MSC sends a Parameter Update order to the MS.
 - h. The MS increments its value of the CallHistoryCount and sends confirmation to the Serving MSC.
 - i. The Serving MSC sends an `ASREPORT` to the Serving VLR indicating the success or failure of the CallHistoryCount update.
 - j. The Serving VLR forwards the `ASREPORT` to the HLR.
 - k. The HLR forwards the `ASREPORT` to the AC.
 - l. The AC sends an `asreport` to the HLR indicating that service is to be provided to the MS.
 - m. The HLR forwards the `asreport` to the Serving VLR.
 - n. The Serving VLR forwards the `asreport` to the Serving MSC.

52
53
54
55
56
57
58
59
60

³COUNT updating may also be directed through an `authreq` (or `asreport` or `afreport`) as shown in Sections 5.4.1, 5.4.2, and 5.4.3. Procedures at the visited system are the same regardless of the message used to communicate the information from the AC to the VLR.

5.4.8 Authentication When SSD is Currently Shared with Another System

This scenario describes the intersystem message flow required to support authentication when SSD is shared with another system. The sequence of events applies to all scenarios when an authentication request is received in the AC.

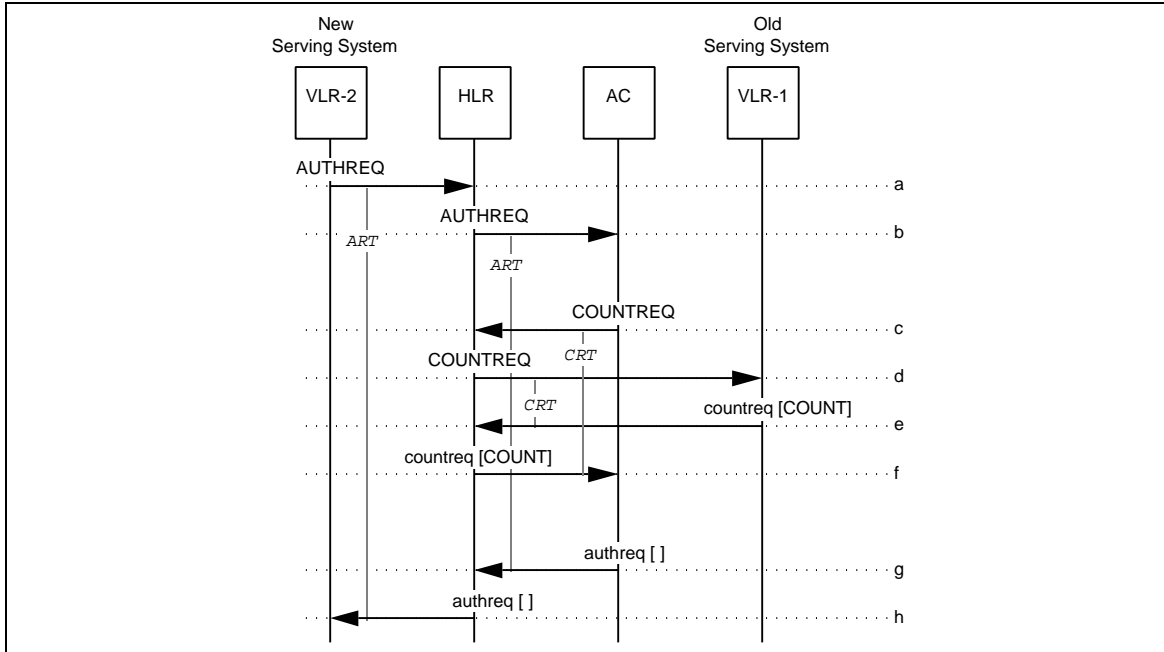

Figure 100 Authentication When SSD is Currently Shared with Another System

1
2
3
4
5
6
7
8
9
10
11
12
13
14
15
16
17
18
19
20
21
22
23
24
25
26
27
28
29
30
31
32
33
34
35
36
37
38
39
40
41
42
43
44
45
46
47
48
49
50
51
52
53
54
55
56
57
58
59
60

- a. An AUTHREQ is sent by a new Serving VLR (VLR-2) to the HLR associated with the newly-served MS.
- b. The HLR forwards the AUTHREQ to the AC.

The AC verifies the MIN and ESN reported by the MS and then executes CAVE using the SSD-A currently stored along with the value of RAND provided by the serving system and other parameters depending on the SystemAccessType to produce an Authentication Response (AUTHR).

The AC verifies that the AUTHR received from the MS matches its CAVE results.
- c. The AC retrieves the current value of COUNT from the previous serving system by sending a COUNTREQ to the subscriber's HLR.
- d. The HLR retrieves the current COUNT value by sending a COUNTREQ to the previous Serving VLR (VLR-1).
- e. VLR-1 returns the current COUNT value to the HLR in a countreq.
- f. The HLR forwards the countreq to the AC.
- g. The AC then verifies that the COUNT received from the MS is consistent with the value retrieved from the previous serving system. The AC sends an authreq to the HLR.
- h. The HLR forwards the authreq to VLR-2.

5.4.9 SSD Update When SSD is Shared

This scenario describes the intersystem message flow required to support SSD updating of an MS in a visited system when SSD is being shared with that system for the SSD Update.

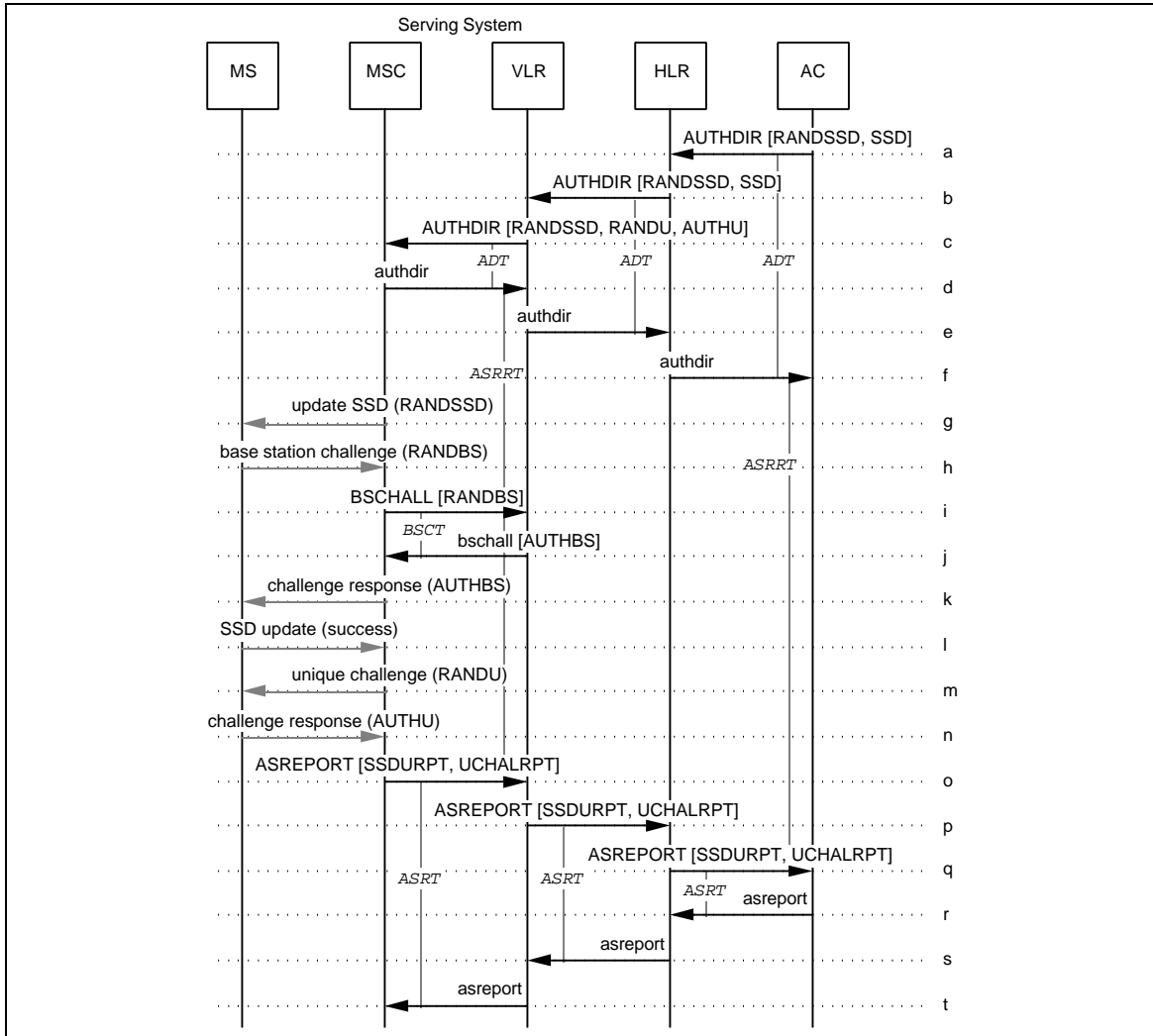

Figure 101 SSD Update When SSD is Shared

- 1
2
3 a. The AC determines that the Shared Secret Data (SSD) in the MS must be updated.
4 This may be the result of administrative procedures at the AC, expiration of an
5 authentication time interval at the AC, or the report of a security violation from a
6 visited system.

7
8 CAVE is executed at the AC to produce a pending value of the SSD using the private
9 A-key and ESN of the MS and a Random Number (RANDSSD) generated by the AC.
10 Note that the AC must retain both the current and pending values of the SSD until
11 informed by the VLR of the outcome of the updating procedure.

12
13 An AUTHDI R is sent from the AC to the HLR associated with the MS.

- 14
15 b. The HLR forwards the AUTHDI R to the current Serving VLR.⁴
16
17 c. The pending SSD shall be used to calculate RANDU, AUTHU and AUTHBS for the
18 SSD Update operation. The VLR chooses a Unique Random Variable (RANDU)
19 and executes CAVE using the pending value of SSD-A, ESN, MIN1, and MIN2
20 associated with the MS to produce a Unique Authentication Response (AUTHU).

21
22 The VLR forwards the AUTHDI R to the MSC-V including RANDU and the expected
23 AUTHU result.

- 24 d. An empty `authdi r` is sent from the Serving MSC to the Serving VLR. The
25 `authdi r` serves only to inform the VLR that the Serving MSC has accepted the
26 directive.

- 27
28 e. The Serving VLR forwards the `authdi r` to the HLR.

- 29
30 f. The HLR forwards the `authdi r` to the AC.

- 31
32 g. The Serving MSC sends an SSD Update order to the MS using the value of
33 RANDSSD provided by the AC. The message may be sent over the control channel
34 or over a voice or traffic channel.

- 35
36 h. The MS executes CAVE to produce a pending value of SSD using the value of
37 RANDSSD provided in the SSD Update order, ESN and A-key.

38
39 The MS selects a Random Number (RANDBS) and sends a Base Station Challenge
40 order to the Serving MSC including the value of RANDBS

41
42 The MS then executes CAVE to produce an Authentication Result (AUTHBS) using
43 the pending value of SSD-A, ESN, MIN1 and the Random Number (RANDBS).

- 44 i. The RANDBS is passed to the Serving VLR by the Serving MSC in a BSCHALL.
45
46 j. The VLR also executes CAVE to produce an Authentication Result (AUTHBS) using
47 the pending value of SSD-A, ESN, MIN1 for the MS and the Random Number
48 (RANDBS) provided by the MS.

49
50
51
52 ⁴SSD updating may also be directed through an `authreq` (or `asreport` or `afreport`) as shown
53 in this Section. Procedures at the visited system are the same regardless of the message
54 used to communicate the information from the AC to the VLR.
55
56
57
58
59
60

1
2
3
4
5
6
7
8
9
10
11
12
13
14
15
16
17
18
19
20
21
22
23
24
25
26
27
28
29
30
31
32
33
34
35
36
37
38
39
40
41
42
43
44
45
46
47
48
49
50
51
52
53
54
55
56
57
58
59
60

The VLR provides its computed value of AUTHBS to the Serving MSC in the `bschal I`.

- k. The Serving MSC passes this information through to the MS in a Base Station Challenge response message.
- l. If the AUTHBS result provided by the VLR matches the value computed by the MS, the MS stores the pending SSD value for use in subsequent executions of CAVE and sends an SSD Update Confirmation message to the Serving MSC.
- m. The Serving MSC sends a Unique Challenge order to the MS using the RANDU provided in the AUTHDI R (Step-c).
- n. The MS executes CAVE using RANDU and the SSD-A currently stored, ESN, MIN1, and MIN2 to produce an Authentication Response for Unique Challenge (AUTHU) which is then sent to the Serving MSC.
- o. The Serving MSC compares the value of AUTHU provided in the AUTHDI R (Step-c) with that received from the MS.
The Serving MSC sends an ASREPORT to the Serving VLR indicating that SSD updating has been successfully completed.
- p. The Serving VLR forwards the ASREPORT to the HLR and removes the pending SSD.
- q. The HLR forwards the ASREPORT to the AC.
- r. The AC stores the pending SSD value for use in subsequent executions of CAVE for the MS if the SSD Update was successful. The AC sends an `asreport` indicating that service is to be provided to the MS. The AC includes the new current SSD in the `asreport` to share the new current SSD value with the VLR.
- s. The HLR forwards the `asreport` to the Serving VLR. The VLR stores the received SSD.
- t. The Serving VLR forwards the `asreport` to the Serving MSC.

5.4.10 AC Initiated Unique Challenge

This scenario describes the intersystem message flow required to support a Unique Challenge where SSD is not shared.

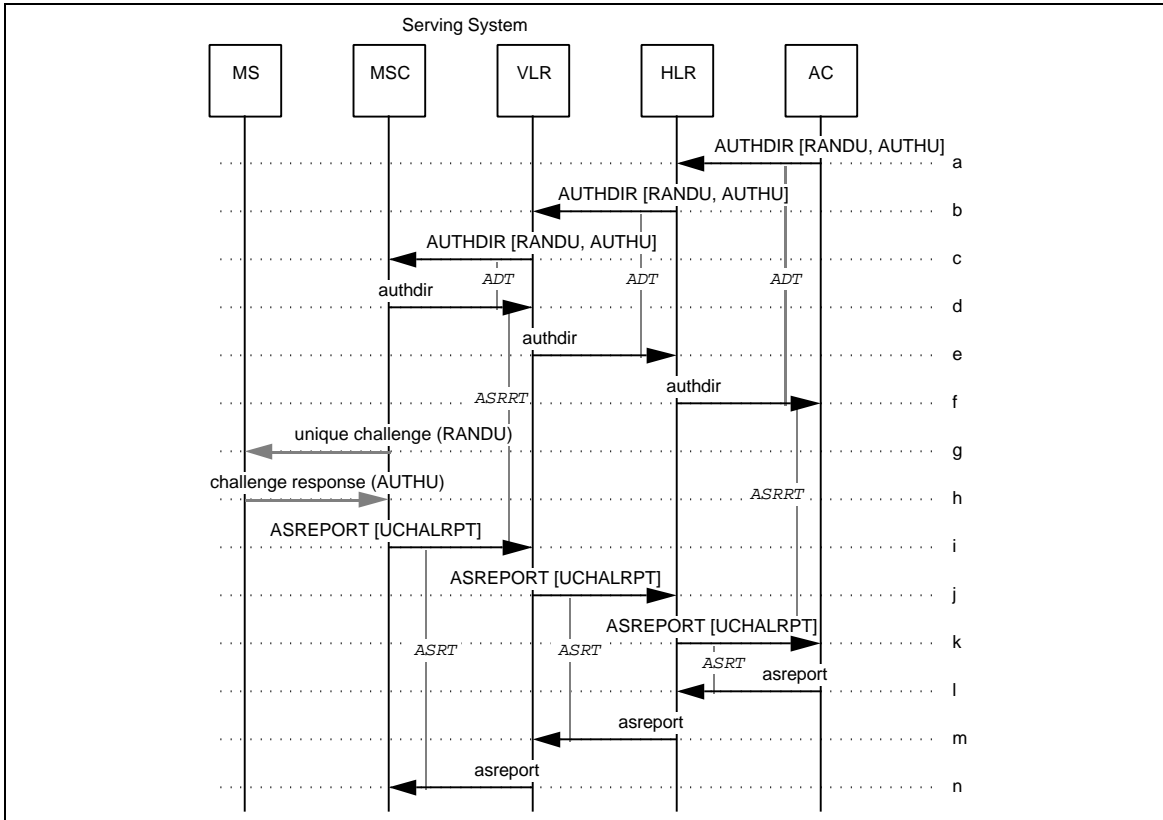

Figure 102 AC Initiated Unique Challenge

- 1
2
3
4
5
6
7
8
9
10
11
12
13
14
15
16
17
18
19
20
21
22
23
24
25
26
27
28
29
30
31
32
33
34
35
36
37
38
39
40
41
42
43
44
45
46
47
48
49
50
51
52
53
54
55
56
57
58
59
60
- a. The AC chooses a Unique Random Variable (RANDU) and executes CAVE using the SSD-A currently stored, ESN, MIN1 and MIN2 associated with the MS to produce an Authentication Response (AUTHU).
An AUTHDI R is sent from the AC to the HLR associated with the MS.
 - b. The HLR forwards the AUTHDI R to the current Serving VLR.⁵
 - c. The Serving VLR forwards the AUTHDI R to the Serving MSC.
 - d. An empty `authdi r` is sent from the Serving MSC to the Serving VLR. The `authdi r` serves only to inform the VLR that the Serving MSC has accepted the directive.
 - e. The Serving VLR forwards the `authdi r` to the HLR.
 - f. The HLR forwards the `authdi r` to the AC.
 - g. The Serving MSC sends a Unique Challenge order to the MS using the RANDU provided in the AUTHDI R (Step-c).
 - h. The MS executes CAVE using RANDU and the SSD-A currently stored, ESN, MIN1, and MIN2 to produce an Authentication Response for Unique Challenge (AUTHU) which is then sent to the Serving MSC.
 - i. The Serving MSC compares the value of AUTHU provided in the AUTHDI R (Step-c) with that received from the MS.
The Serving MSC sends an ASREPORT to the VLR indicating the success or failure of the Unique Challenge.
 - j. The VLR forwards the ASREPORT to the HLR.
 - k. The HLR forwards the ASREPORT to the AC.
 - l. The AC returns an `asreport` to the HLR.
 - m. The HLR forwards the `asreport` to the Serving VLR.
 - n. The Serving VLR forwards the `asreport` to the Serving MSC.

⁵A Unique Challenge may also be directed through an `authreq` (or `asreport` or `afreport`) as shown in this Section. Procedures at the visited system are the same regardless of the message used to communicate the information from the AC to the VLR.

5.4.11 VLR Initiated Unique Challenge When SSD is Shared

This scenario describes the intersystem message flow required to support a Unique Challenge when SSD is shared.

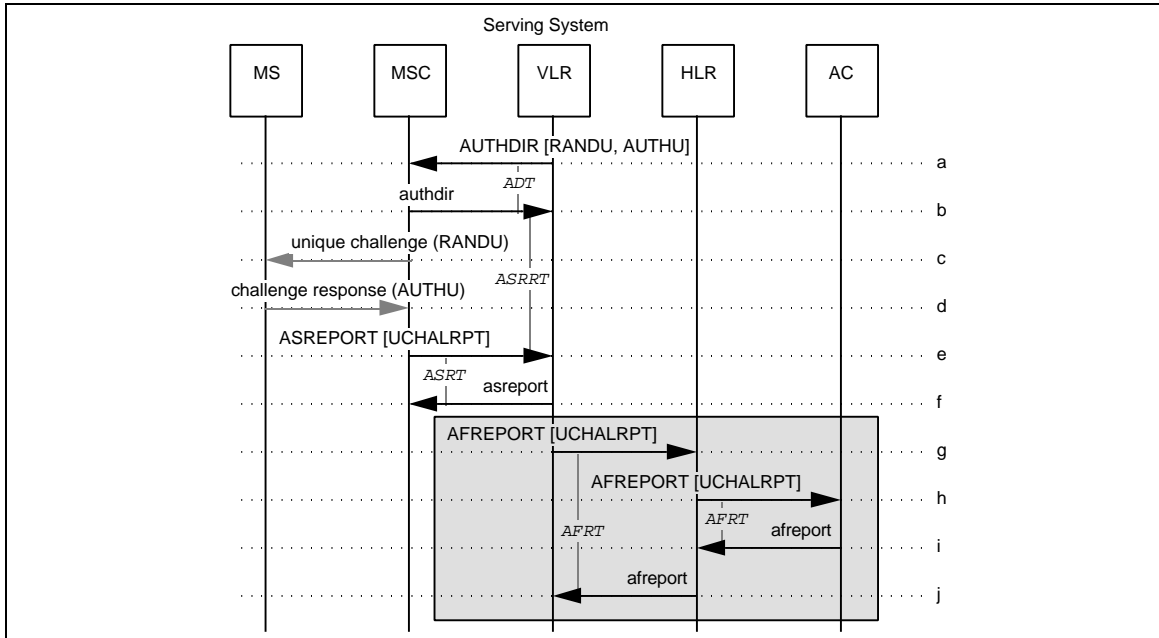

Figure 103 VLR Initiated Unique Challenge When SSD is Shared. The Serving VLR chooses a Unique Random Variable (RANDU) and executes CAVE using the SSD-A currently stored, ESN, MIN1 and MIN2 associated with the MS to produce an Authentication Response for Unique Challenge (AUTHU).

The VLR sends an AUTHDI R to the current Serving MSC.

- b. The `authdir` from the Serving MSC to the VLR serves only to inform the VLR that the Serving MSC has accepted the directive.
- c. The Serving MSC sends a Unique Challenge order to the MS using the RANDU provided in the AUTHDI R (Step-a).
- d. The MS executes CAVE using RANDU and the SSD-A currently stored, ESN, MIN1, and MIN2 to produce a Unique Challenge Response (AUTHU) which is then sent to the Serving MSC.
- e. The Serving MSC compares the value of AUTHU provided in the AUTHDI R (Step-a) with that received from the MS.
The Serving MSC sends an ASREPORT to the VLR indicating that the Unique Challenge has been completed.
- f. The Serving VLR returns an `asreport` to the Serving MSC.
- g. If the operation failed, the Serving VLR sends an AFREPORT to the HLR.
- h. The HLR forwards the AFREPORT to the AC.

1
2
3
4
5
6
7
8
9
10
11
12
13
14
15
16
17
18
19
20
21
22
23
24
25
26
27
28
29
30
31
32
33
34
35
36
37
38
39
40
41
42
43
44
45
46
47
48
49
50
51
52
53
54
55
56
57
58
59
60

- i. The AC sends an **afreport** to the HLR, indicating the action to be requested of the VLR.
- j. The HLR forwards the **afreport** to the VLR.

5.4.12 RegistrationCancellation with CallHistoryCount Report

This scenario describes the intersystem message flows required to support a RegistrationCancellation when SSD is shared with the previous Serving VLR.

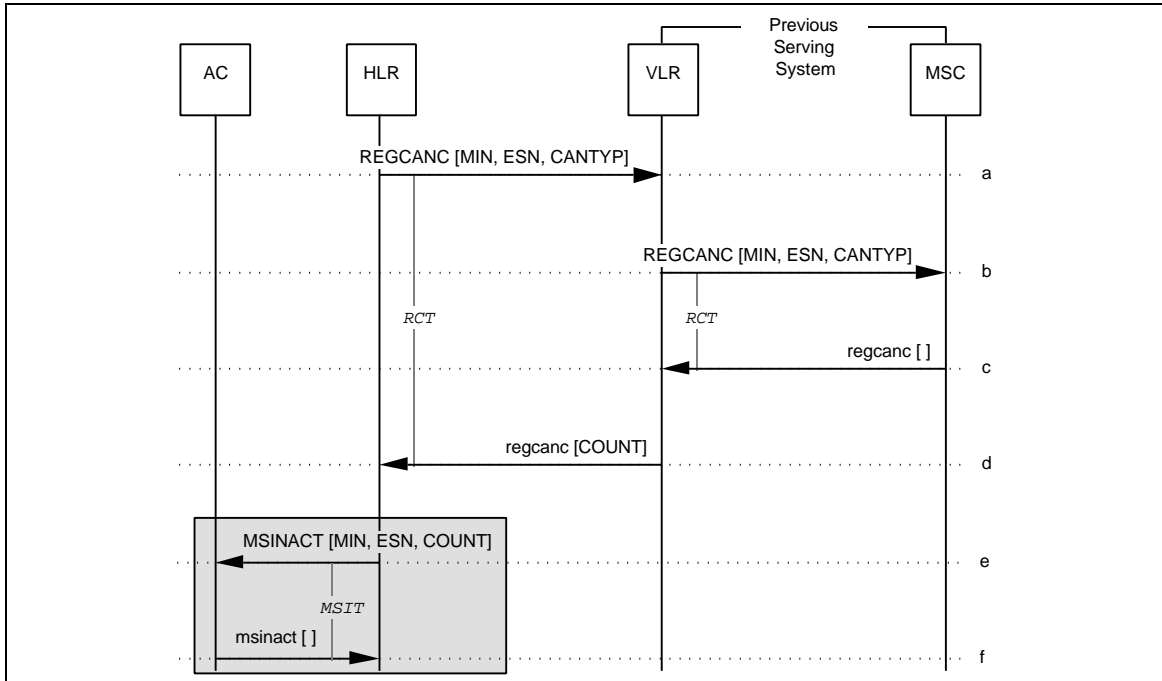

Figure 104 RegistrationCancellation with CallHistoryCount Report

- a. After determining that a roaming MS has left the service area in which it had been registered, the HLR sends a REGCANC to the previous Serving VLR. The VLR, upon receipt of the cancellation message, essentially removes all record of the MS from its memory.
- b. The VLR sends a REGCANC to the previous Serving MSC. The MSC, upon receipt of the cancellation message, may discontinue in progress calls or services for the identified MS and essentially removes all record of the MS from its memory. Parameters are as in Step-a.
- c. The previous Serving MSC acknowledges receipt of the REGCANC by sending an empty regcanc to the previous Serving VLR.
- d. The previous Serving VLR acknowledges receipt of the REGCANC by sending a regcanc to the HLR. The Serving VLR includes the CallHistoryCount parameter if SSD is shared.
- e. If the CallHistoryCount was received from the previous Serving VLR and the CallHistoryCount in the AC must be updated, the HLR sends an MSI NACT to the AC and relays the received CallHistoryCount parameter.
- f. The AC acknowledges receipt of the MSI NACT by sending an msinact to the HLR.

5.5 Basic Feature Processing

This section illustrates some typical scenarios related to basic feature processing.

5.5.1 Feature Request Confirmation with Release

This scenario describes a successful feature request by an authorized MS. The Serving MSC provides the served MS with feature confirmation and then releases the call.

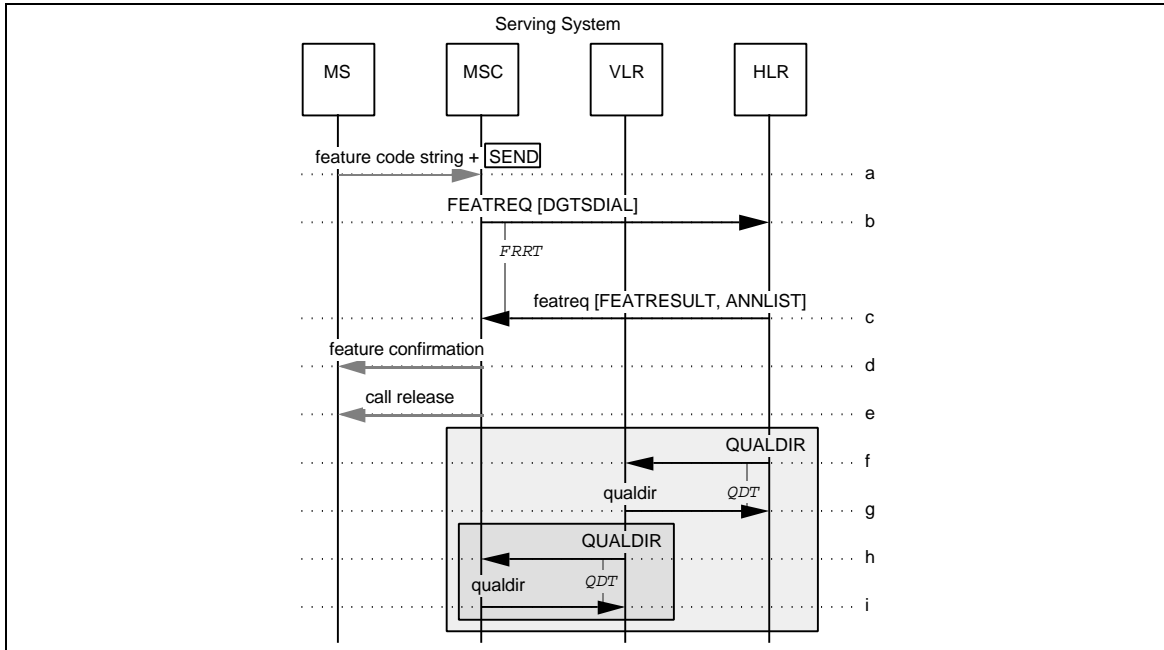

Figure 105 Feature Request Confirmation with Release

1
2
3
4
5
6
7
8
9
10
11
12
13
14
15
16
17
18
19
20
21
22
23
24
25
26
27
28
29
30
31
32
33
34
35
36
37
38
39
40
41
42
43
44
45
46
47
48
49
50
51
52
53
54
55
56
57
58
59
60

- a. Dialed digits are received by the Serving MSC. During analysis of the dialed digits, the Serving MSC detects a feature code string.
- b. The dialed digits are included in a FEATREQ and sent from the Serving MSC to the HLR associated with the MS.
- c. The HLR sends a featreq to the Serving MSC containing the feature request confirmation indication and, optionally, parameters which specifically indicate the treatment the Serving MSC shall provide to the served MS (e.g., the AnnouncementList parameter).
- d. When the featreq is received from the HLR, the Serving MSC provides treatment to the served MS based on the information contained in the response. In this case, the treatment is to apply feature confirmation.
- e. The Serving MSC releases the call.
- f. If the feature request resulted in a change to the MS's service profile, the HLR reports the change through a QUALDI R to the VLR where the MS is registered.
- g. The VLR returns a qual di r to the HLR.
- h. The VLR reports the change in the MS's service profile by sending a QUALDI R to the Serving MSC.
- i. The Serving MSC returns a qual di r to the VLR.

5.5.2 Feature Request Confirmation with Call Routing

This scenario describes a successful feature request by an MS. The Serving MSC provides the served MS with feature confirmation and then routes the call as directed by the HLR.

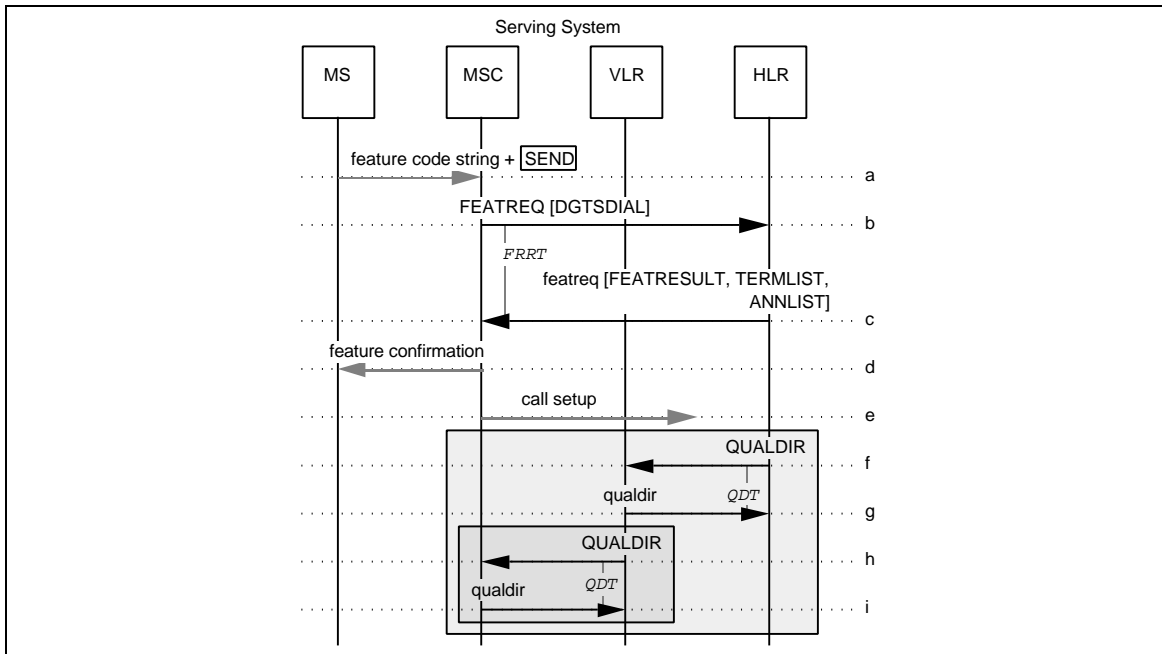

Figure 106 Feature Request Confirmation with Call Routing

- a-b. Same as Section 5.5.1, Steps a-b.
- c. The HLR sends a `featreq` to the Serving MSC containing the feature request confirmation indication and routing instructions in the TerminationList parameter.
- d. When the `featreq` is received from the HLR, the Serving MSC provides treatment to the served MS based on the information contained in the response. In this case, the treatment is to apply feature confirmation.
- e. The Serving MSC establishes a call using the routing information contained in the TerminationList parameter.
- f-i. Same as Section 5.5.1, Steps f-i.

5.5.3 Feature Request Denial with Call Release

This scenario describes an unsuccessful feature request by an MS. The Serving MSC provides the served MS with feature denial and then releases the call.

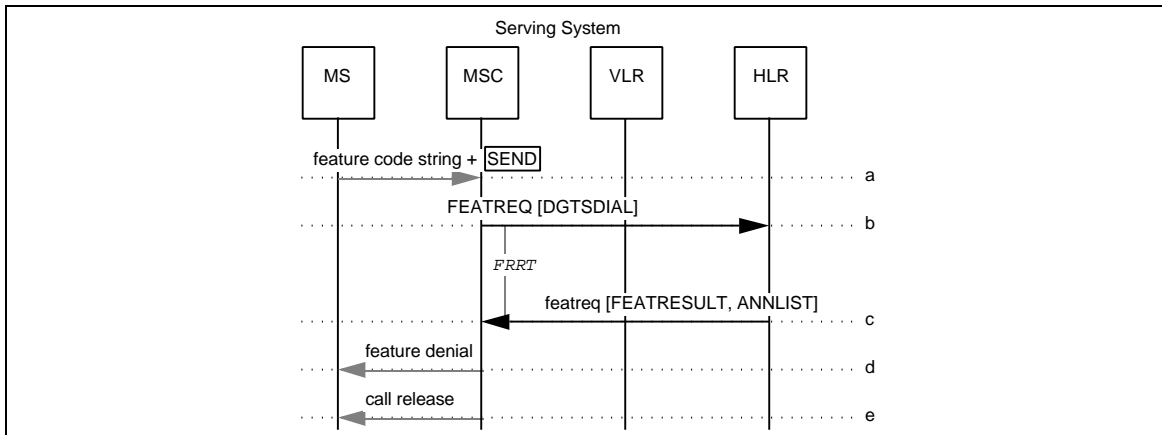

Figure 107 Feature Request Denial with Call Release

- a-b. Same as Section 5.5.1, Steps a-b.
- c. The HLR sends a **featreq** to the Serving MSC containing the feature request denial indication and, optionally, parameters which specifically indicate the treatment the Serving MSC shall provide to the served MS.
- d. When the **featreq** is received from the HLR, the Serving MSC provides treatment to the served MS based on the information contained in the response. In this case, the treatment is to apply feature denial.
- e. The Serving MSC releases the call.

5.5.4 Feature Request After Handoff

This scenario describes a successful feature request by an authorized MS which occurs during a call and after intersystem handoff. The Anchor MSC provides the served MS with feature confirmation and then processes the request.

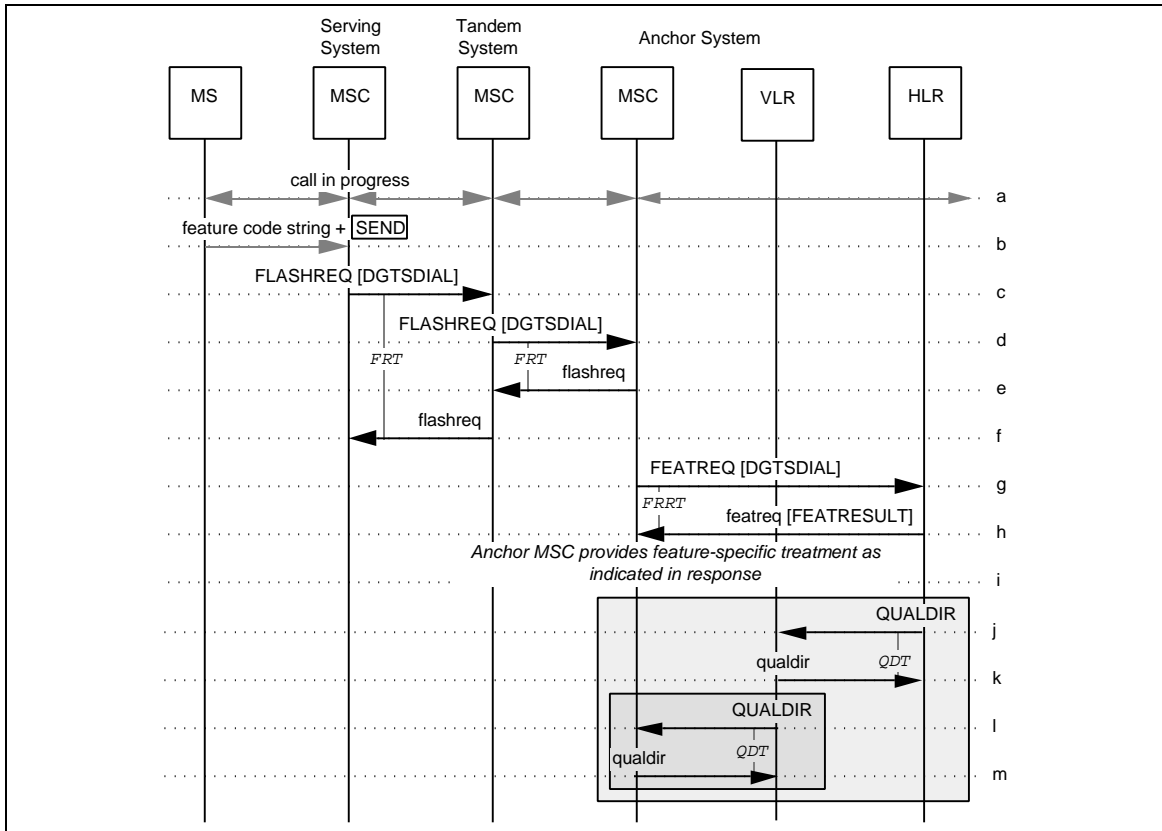

Figure 108 Feature Request After Handoff

- a. A call involving the served MS is in progress.
- b. The served MS enters a feature code string and sends a Flash Request to the Serving MSC (i.e., presses the Ψ_X (SEND) key).
- c. The Serving MSC sends a FLASHREQ toward the Anchor MSC in the call (through the Tandem MSC in this scenario).
- d. The Tandem MSC forwards the FLASHREQ toward the Anchor MSC in the call.
- e. The Anchor MSC returns a flashreq to the requesting system (i.e., the Tandem MSC in this scenario).
- f. The Tandem MSC forwards the flashreq to the Serving MSC.
- g. During analysis of the dialed digits received in the FLASHREQ, the Anchor MSC detects the feature code string. The dialed digits are included in a FEATREQ and sent from the Anchor MSC to the HLR associated with the MS.

1
2
3
4
5
6
7
8
9
10
11
12
13
14
15
16
17
18
19
20
21
22
23
24
25
26
27
28
29
30
31
32
33
34
35
36
37
38
39
40
41
42
43
44
45
46
47
48
49
50
51
52
53
54
55
56
57
58
59
60

- h. The HLR sends a **featreq** to the Anchor MSC containing the feature request result and, optionally, parameters which specifically indicate the treatment the Serving MSC shall provide to the served MS (e.g., the AnnouncementList parameter).
- i. When the **featreq** is received from the HLR, the Anchor MSC provides treatment to the served MS based on the information contained in the response.
- j. If the feature request resulted in a change to the MS's service profile, the HLR reports the change through a **QUALDI R** to the VLR where the MS is registered.
- k. The VLR returns a **qual di r** to the HLR.
 - l. The VLR reports the change in the MS's service profile by sending a **QUALDI R** to the Serving MSC.
- m. The Serving MSC returns a **qual di r** to the VLR.

5.5.5 Service Provider Initiated Profile Change

This scenario describes a change in the subscriber's profile initiated by the service provider.

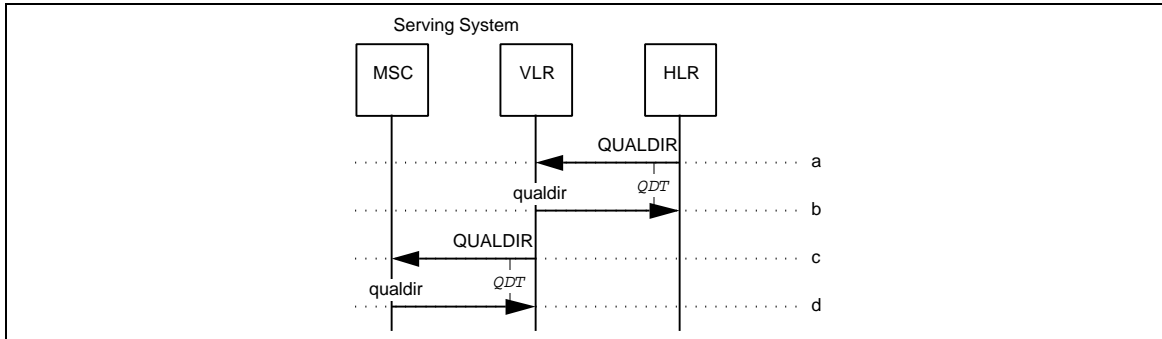

Figure 109 Service Provider MWN Profile Change

- a. The HLR reports the change in the MS's service profile by sending a **QUALDIR** to the VLR where the MS is registered.
- b. The VLR sends a **qualdir** to the HLR.
- c. The VLR reports the change in the MS's service profile by sending a **QUALDIR** to the Serving MSC.¹
- d. The Serving MSC sends a **qualdir** to the VLR.

¹If an intersystem handoff has occurred, the InformationForward operation may be initiated by the Anchor MSC on receipt of the **QUALDIR**.

5.5.6 Call Origination without Profile

This scenario describes the delivery of the profile information to the Serving MSC when call origination is attempted by a registered MS without the profile being present in the Serving MSC.

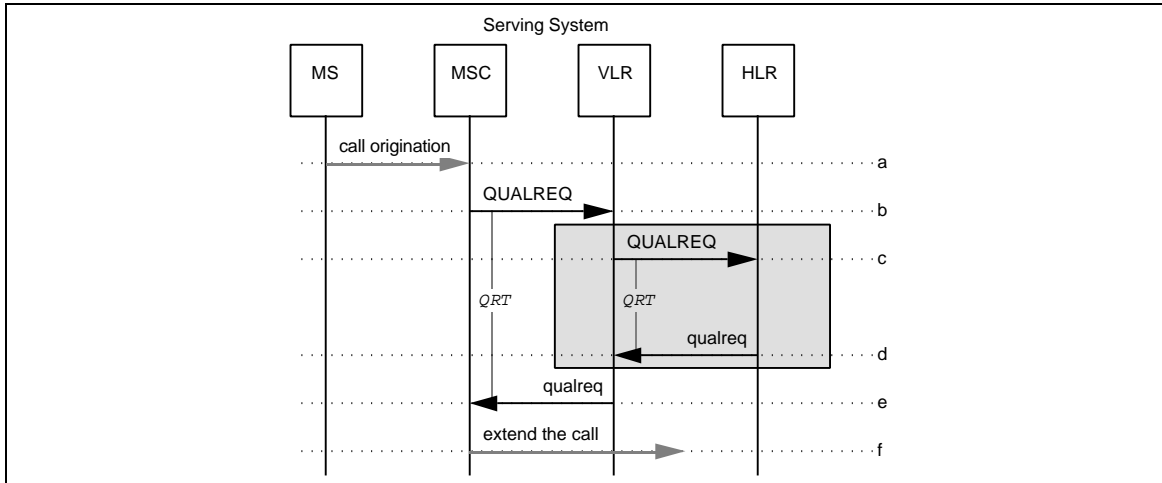

Figure 110 Call Origination without Profile

- a. The Serving MSC receives a call origination from the served MS.
- b. If the service profile of the MS is unknown to the MSC, it sends a QUALREQ to the VLR.
- c. If the service profile of the MS is unknown to the VLR, it sends a QUALREQ to the HLR associated with the MS.
- d. The HLR sends a qual req to the Serving MSC's VLR, including the MS's service profile information.
- e. The VLR sends a qual req to the Serving MSC, including the MS's service profile information.
- f. The Serving MSC then continues with call origination.

5.5.7 Termination or Message Delivery without Profile

This scenario describes the delivery of the profile information to the Serving MSC when call termination or message delivery is attempted to a registered MS without the profile being present in the Serving MSC.

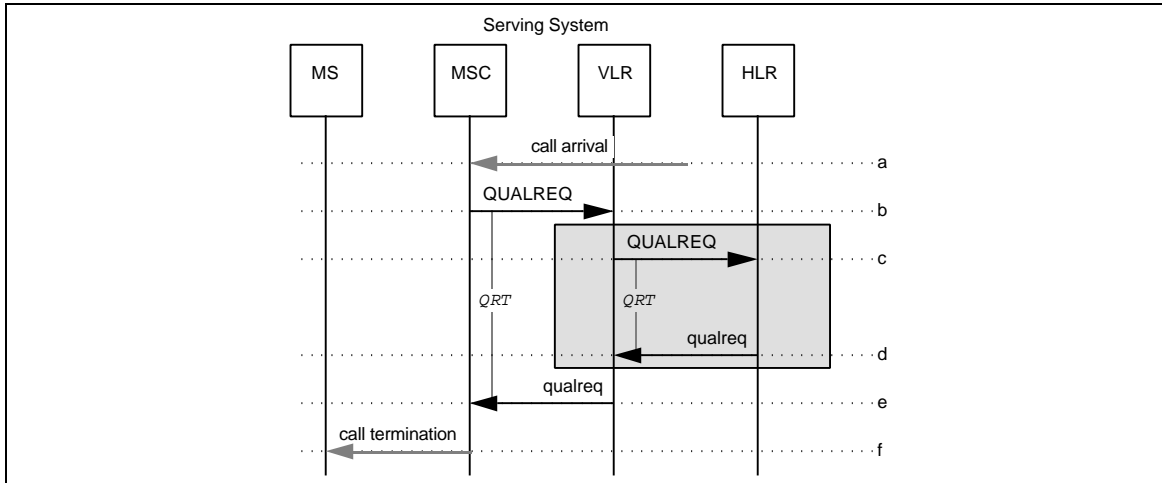

Figure 111 Call Termination or Message Delivery without Profile

- The Serving MSC receives a call termination (or message delivery) request for the served MS.
- If the service profile of the MS is unknown to the MSC, it sends a QUALREQ to the VLR.
- If the service profile of the MS is unknown to the VLR, it sends a QUALREQ to the HLR associated with the MS.
- The HLR sends a qualreq to the Serving MSC's VLR, including the MS's service profile information.
- The VLR sends a qualreq to the Serving MSC, including the MS's service profile information.
- The call termination (or message delivery) then proceeds.

5.5.8 Feature Request (Registration) with SPINI Active

This scenario describes a Feature Request when registering a feature with a forward-to or diversion termination address that requires prompting for a SPINI PIN.

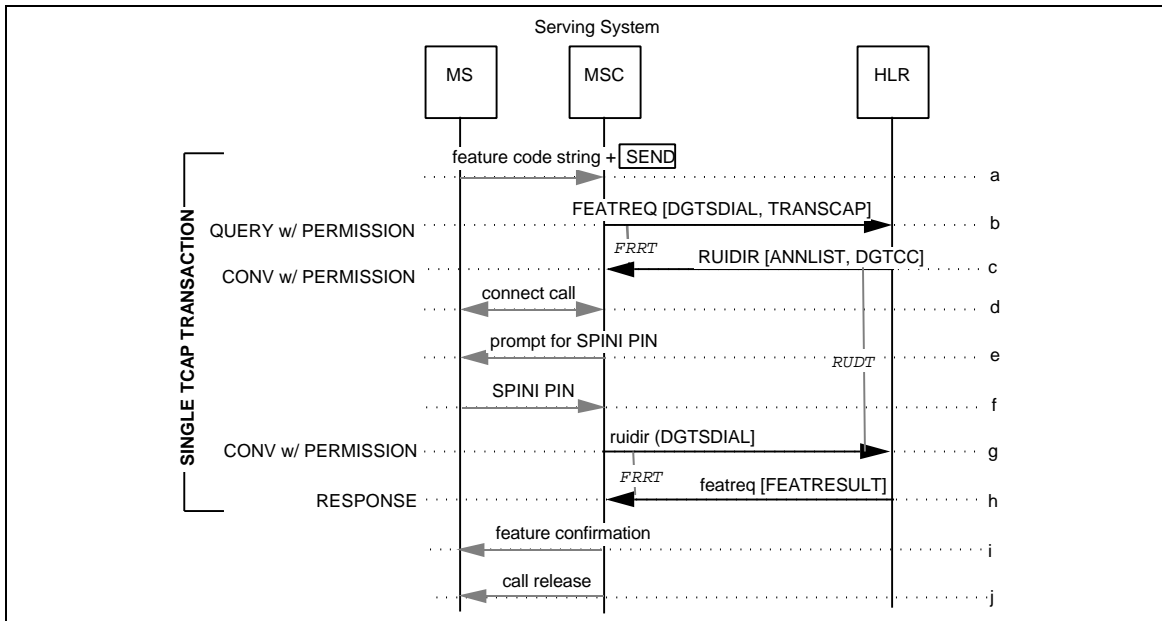

Figure 112 Feature Registration with SPINI Active

- a. Dialed digits are received by the Serving MSC. During analysis of the dialed digits, the Serving MSC detects a feature code string.
- b. The dialed digits are included in the FEATREQ and sent from the Serving MSC to the HLR associated with the MS. The TransactionCapability parameter is also included in the FEATREQ, indicating that the Serving MSC supports receiving RUIDIRs.
- c. The HLR recognizes the dialed digits as a feature registration with a forward-to or diversion termination address that matches a SPINI Trigger. The HLR send a RUI DI R to the Serving MSC.
- d. On receipt of the RUI DI R, the Serving MSC turns off the FEATREQ timer (FRRT) and provides call treatment as indicated in the received message. In this case, the treatment is to answer the call (i.e., connect the calling party to the subsystem capable of user interaction), and...
- e. ...prompt the user based on the information in the received RUIDIR (in the DigitCollectionControl parameter) and wait for digits.
- f. The user responds with the SPINI PIN.
- g. The Serving MSC sends a rui di r to the HLR and includes the digits dialed by the user. The Serving MSC restarts the FRRT Timer.

1
2
3
4
5
6
7
8
9
10
11
12
13
14
15
16
17
18
19
20
21
22
23
24
25
26
27
28
29
30
31
32
33
34
35
36
37
38
39
40
41
42
43
44
45
46
47
48
49
50
51
52
53
54
55
56
57
58
59
60

- h. The HLR updates the served MS's feature registration information and sends a **featreq** including the FeatureResult parameter indicating successful feature operation to the Serving MSC.
- i. The Serving MSC turns off the FEATREQ timer (FRRT) and provides treatment to the served MS as indicated in the received **featreq**. In this case, the treatment is to provide feature confirmation and...
- j. ...release the call.

5.6 Automatic Roaming Maintenance

This section illustrates some typical scenarios related to automatic roaming maintenance.

5.6.1 Recovery from Data Failure at the HLR

This scenario describes the recovery procedures initiated by an HLR when it suffers a data failure.

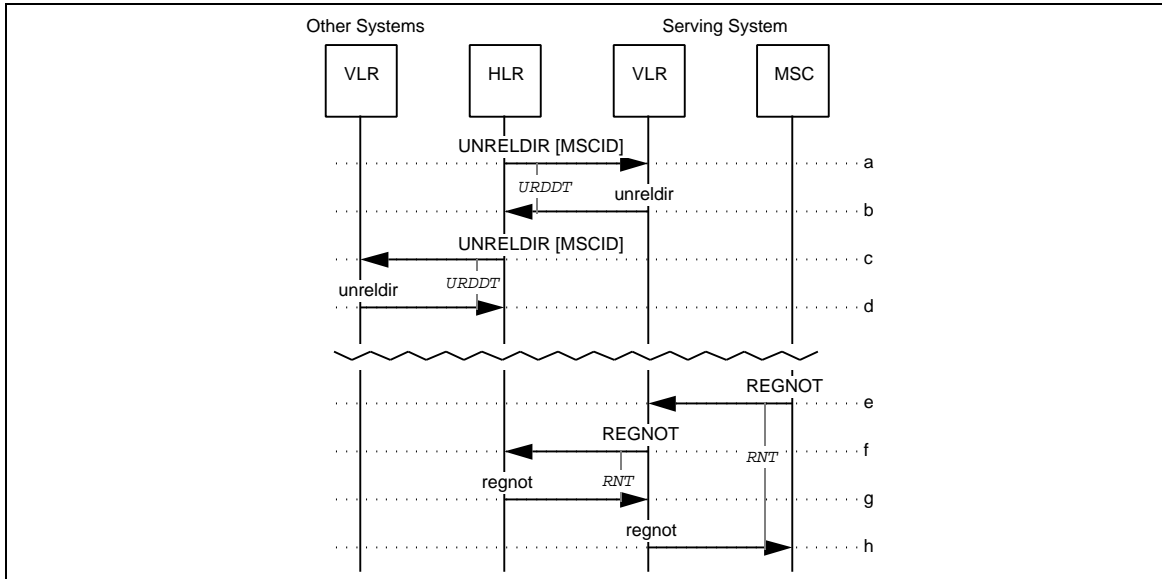

Figure 113 Recovery from data failure at the HLR

- 1
2
3
4 a, c. After the HLR returns to a stable state following a data failure, it initiates recovery
5 procedures by sending an UNRELDI R to all of its associated VLRs.
6
7 b,d. The VLRs then remove all record of the MSs associated with that HLR from their
8 memory and respond with an unrel di r.
9
10 e. At some future point in time, the MSC detects the presence of an MS within its
11 serving area and sends a REGNOT to its VLR.
12
13 f. The VLR then sends a REGNOT to the HLR associated with that MS, allowing the
14 HLR to reconstruct its internal data structures in an incremental fashion.
15
16 g. The HLR responds with a regnot.
17
18 h. The VLR returns a regnot to the Serving MSC.
19

20 **5.6.2 VLR-Initiated Bulk Deregistration**

21
22 For a description of the process by which a VLR initiates bulk deregistration of its visiting
23 subscribers, see Section 4.
24
25
26
27
28
29
30
31
32
33
34
35
36
37
38
39
40
41
42
43
44
45
46
47
48
49
50
51
52
53
54
55
56
57
58
59
60

6 VOICE FEATURE SCENARIOS

This section depicts the interactions between network entities in various situations related to voice feature support under automatic roaming conditions.

Unless otherwise noted, the scenarios in this section depict features operating individually; i.e., feature interactions are not considered unless specifically noted.

Also, please note that the scenarios in this section do not include a complete listing of operation parameters, either in the figures or in the accompanying text descriptions. Parameters are included where they are deemed necessary to improve the understanding of the scenario. For a complete description of the parameters associated with each operation, refer to Section 4.

6.1 Call Delivery

This section depicts the interactions between network entities in various situations related to automatic roaming and Call Delivery (CD). These scenarios are for illustrative purposes only.

6.1.1 CD Demand Activation or De-Activation

For a description of the demand activation or de-activation of CD by an authorized MS, see Section 5.5.1.

1
2
3
4
5
6
7
8
9
10
11
12
13
14
15
16
17
18
19
20
21
22
23
24
25
26
27
28
29
30
31
32
33
34
35
36
37
38
39
40
41
42
43
44
45
46
47
48
49
50
51
52
53
54
55
56
57
58
59
60

6.1.2 CD Invocation to an Idle MS on Another MSC

This scenario describes call delivery to an MS that is outside the serving area of the MSC where the call originates. MSCs in the functional model described in *TIA/EIA-41* Chapter 1 contain switching functions only and must interact with their associated HLR and VLR to obtain database information for an MS; in a real application, the HLR/VLR functions may be integrated with the MSC.

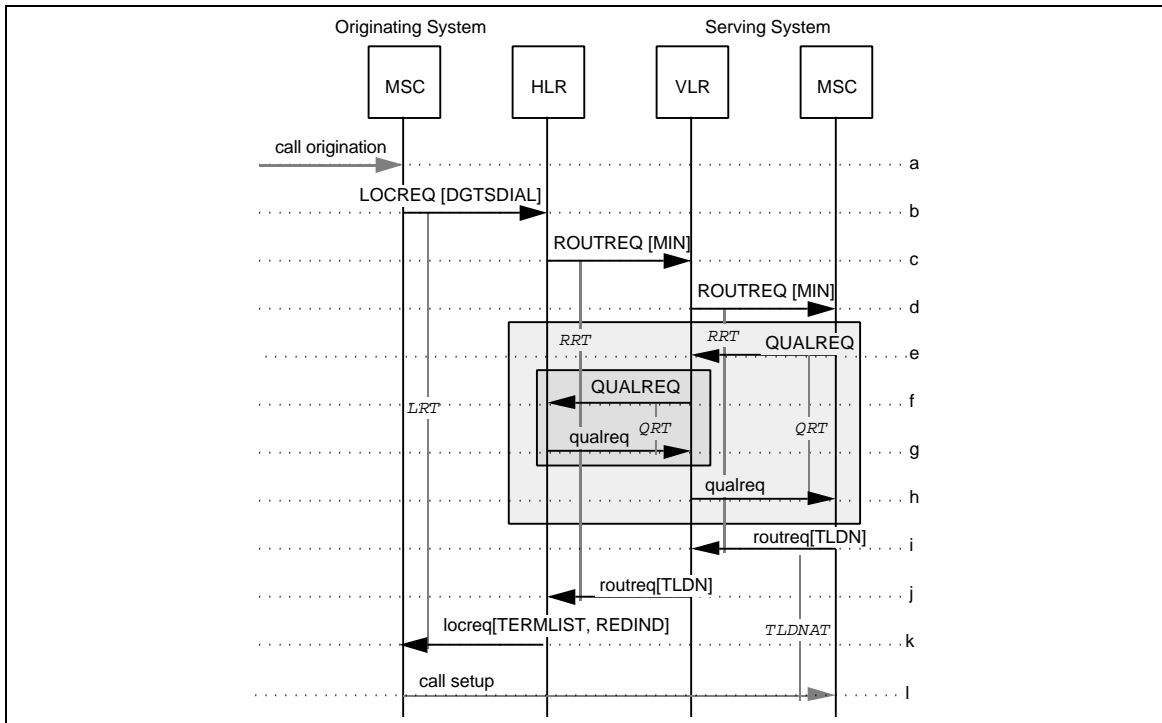

Figure 114 CD Invocation to an Idle MS on Another MSC

- A call origination and the dialed MS address digits (i.e., directory number) are received by the Originating MSC.
- The Originating MSC sends a **LOCREQ** to the HLR associated with the MS; this association is made through the dialed MS address digits (which may not be the MIN).
- If the dialed MS address digits are assigned to a legitimate subscriber, the HLR sends a **ROUTREQ** to the VLR where the MS is registered.
- The VLR then forwards the **ROUTREQ** to the current Serving MSC. Note that the MS may have roamed within the domain of the Serving VLR and reported its new location to that VLR (via the new Serving MSC); the Serving VLR may not have reported this change in location to the HLR.

In reaction to the **ROUTREQ**, the Serving MSC consults its internal data structures to determine if the MS is already engaged in a call on this MSC. In this scenario, since the MS is idle, we are assuming that the MS is not known to the Serving MSC.

- The Serving MSC may then obtain the service profile of the MS from its VLR by sending it a **QUALREQ**.

1
2
3
4
5
6
7
8
9
10
11
12
13
14
15
16
17
18
19
20
21
22
23
24
25
26
27
28
29
30
31
32
33
34
35
36
37
38
39
40
41
42
43
44
45
46
47
48
49
50
51
52
53
54
55
56
57
58
59
60

This step can be eliminated if the service profile is obtained by the Serving MSC prior to the termination attempt (e.g., when the MS registers). Subsequent scenarios do not explicitly show this step; they assume that the Serving MSC either already has the profile available when the ROUTREQ arrives or obtains the profile in a manner similar to that shown here.

- f. If the MS is unknown to the VLR or if the information requested by the MSC is not available at the VLR, the VLR sends a QUALREQ to the HLR associated with the MS.
- g. The HLR sends a qualreq to the VLR.
- h. The VLR sends a qual req to the Serving MSC.
- i. The Serving MSC allocates a TLDN (Temporary Local Directory Number) and returns this information to the VLR in the routreq.
- j. The VLR sends the routreq to the HLR.
- k. When the routreq is received by the HLR, it returns a locreq to the Originating MSC. The locreq includes routing information in the form of the TerminationList parameter, along with an indication of the reason for extending the incoming call (i.e., for CD) in the DMH_RedirectionIndicator parameter.
- l. The Originating MSC establishes a voice path to the Serving MSC using existing interconnection protocols (e.g. SS7) and the routing information specified in the locreq.

6.1.3 CD Invocation to an Idle, Local MS

This scenario describes CD invocation to an idle MS that is served by the MSC where the call originates.

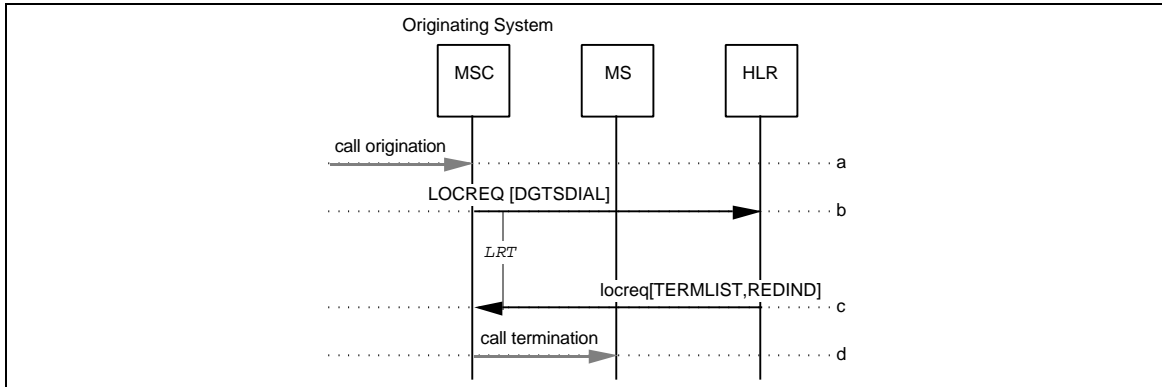

Figure 115 CD Invocation to an Idle, Local MS

- a-b. Same as CD, Section 6.1.2, Steps a-b.
- c. If the dialed MS address digits are assigned to a legitimate subscriber and the HLR determines that the subscriber is currently served by the Originating MSC, the HLR sends a `locreq` to the Originating MSC.
- d. The Originating MSC, recognizing itself as the Serving MSC via the `MSCID` parameter contained in the `TerminationList` parameter, then attempts to terminate the call to the MS identified in the `locreq`.

6.1.4 CD Invocation to a Busy MS

This scenario describes CD invocation to an MS that is busy in a call outside of the serving area where the call originates.

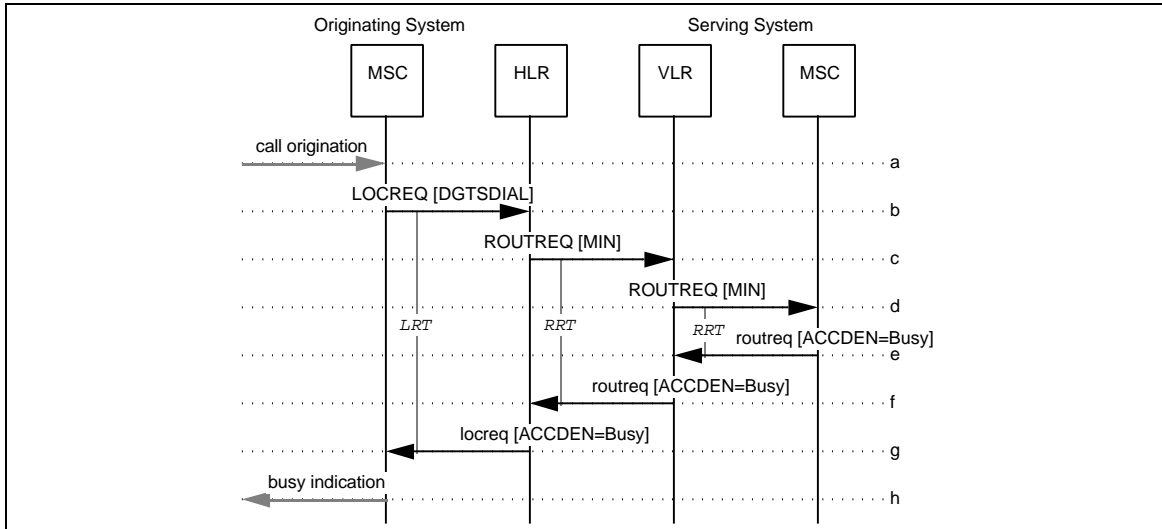

Figure 116 CD Invocation to a Busy MS

- a-d. Same as CD, Section 6.1.2, Steps a-d.
- e. In reaction to the ROUTREQ, the Serving MSC checks its internal data structures and determines that the MS is busy in another call. The status of the MS is returned to the VLR by the Serving MSC via the AccessDeniedReason parameter in the routreq.¹
- f. The VLR sends the routreq to the HLR.
- g. The HLR returns the busy status to the Originating MSC in the locreq.
- h. The Originating MSC then returns a busy indication to the calling party.

¹In some environments it may be necessary to return a TLDN in addition to, or in place of, the MS status.

6.1.5 CD Invocation with No Page Response or No Answer

This scenario describes CD invocation to an MS when no page response or no answer is received by the Serving MSC after TLDN call arrival.

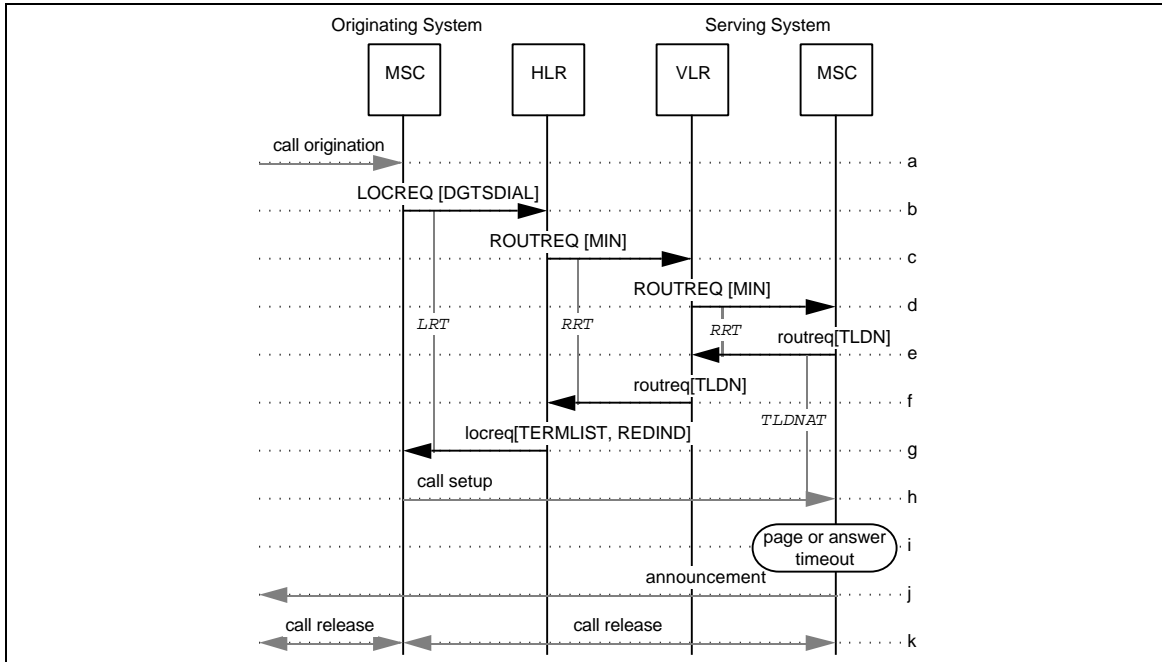

Figure 117 CD Invocation with No Page Response or No Answer

- a-d. Same as CD, Section 6.1.2, Steps a-d.
- e-h. Same as CD, Section 6.1.2, Steps g-j, respectively.
- i. Either the MS fails to respond to the page or does not answer after alerting.
- j. The Serving MSC routes the call to an appropriate tone or announcement.
- k. The call is then disconnected using the protocols defined by the interconnection method.

6.1.6 CD Invocation to an Inaccessible MS

This scenario describes CD invocation to an MS that is inaccessible due to (a) CD inactive, (b) MS inactive, or (c) MS unregistered.

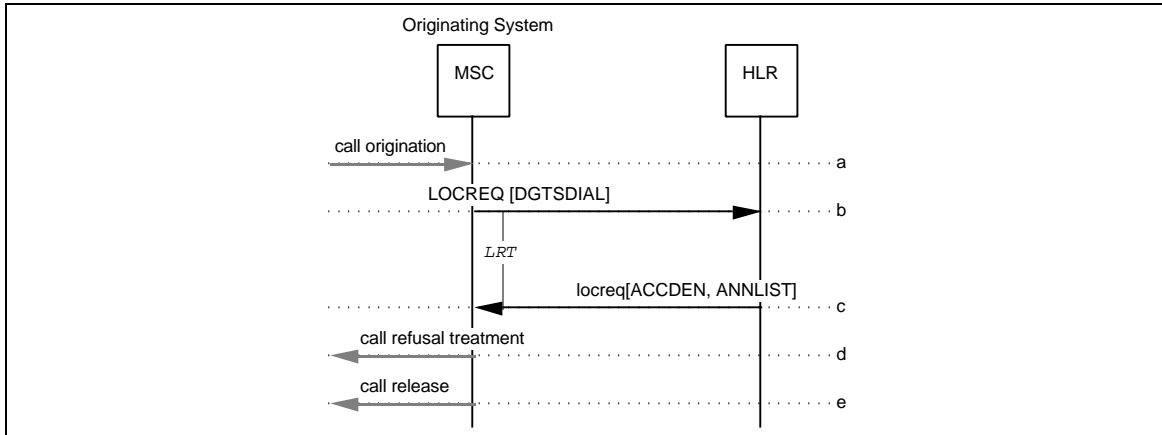

Figure 118 CD Invocation to an Inaccessible MS

- a-b. Same as CD, Section 6.1.2, Steps a-b.
- c. The HLR determines that the MS is not accessible (e.g., CD is inactive, MS is inactive, or MS is not registered). The HLR returns a `locreq` to the Originating MSC including the reason for denying access in the `AccessDeniedReason` parameter.
- d. The Originating MSC provides treatment to the served MS as implied by the `AccessDeniedReason` parameter and, if present, the `AnnouncementList` parameter. In this case, the treatment is to provide call refusal treatment.
- e. The Originating MSC releases the call.

6.1.7 CD Invocation with Intersystem Paging

This scenario describes CD invocation involving intersystem paging from the serving system to border systems. Intersystem paging may help overcome location uncertainties in border system areas allowing paging to be performed in border systems and by performing call routing towards the system where the subscriber is found.

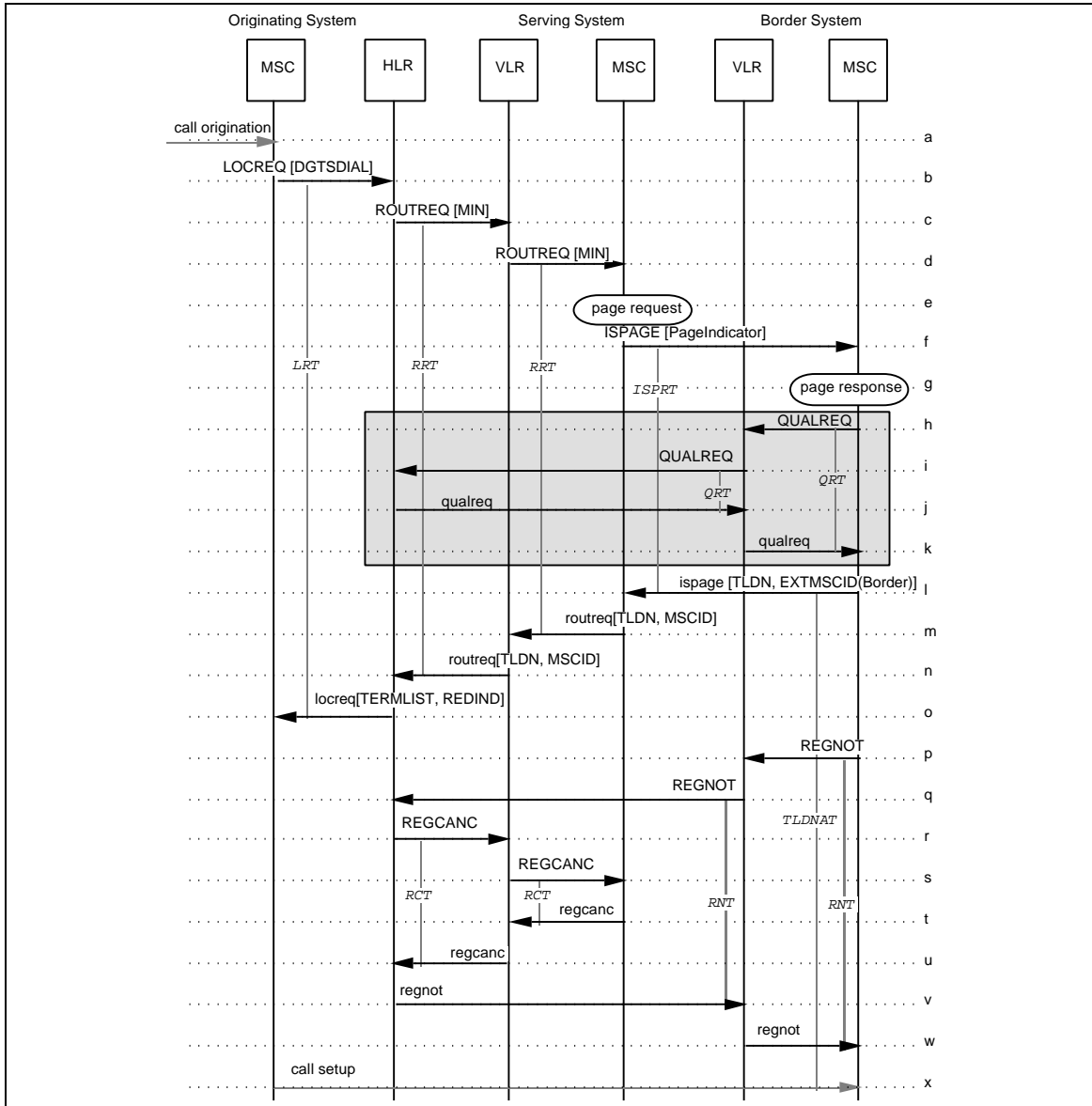

Figure 119 CD Invocation with Intersystem Paging

- a-d. Same as CD, Section 6.1.2, Steps a-d.
- e-f. Before initiating local paging, at the time of local page initiation or after first page time-out, the Serving MSC may send an ISPAGE to one or more bordering MSCs

1
2
3 according to its “topographical map” with a parameter indicating an area where the
4 subscriber’s presence was last detected and a parameter indicating whether to page or
5 just listen for an unsolicited page response. This I SPAGE contains the MSCID of
6 the Originating MSC in order that subsequent message exchanges work properly.
7 The Serving MSC also passes the information needed if call redirection is required.

8
9 The Border MSC that receives the I SPAGE may initiate paging (i.e., if directed).

- 10
11 g. If a page response is received at the Border MSC...
- 12
13 h. Optionally the Border MSC sends a QUALREQ to the VLR indicating Border Access.
- 14
15 i. If the service profile of the MS is unknown to the VLR, it sends a QUALREQ to the
16 HLR associated with the MS.
- 17
18 j. The HLR sends a qual req to the Border MSC’s VLR, including the MS’s service
19 profile information.
- 20
21 k. The VLR sends a qual req to the Border MSC, including the MS’s service profile
22 information. The Border MSC then assigns the MS to a voice/traffic channel and
23 allocates a TLDN. The Border MSC further confirms the MS’s presence (e.g., via
24 SAT detection, through a voice channel audit, or both).
- 25
26 If the MS is authentication capable, optionally authenticate it using a control channel
27 (i.e., as in 5.4.3), or a voice channel (i.e., as in 5.4.4).
- 28
29 l. When the Border MSC assigns the MS to a voice/traffic channel, the Border MSC
30 sends an i spage containing a TLDN and the MSCID of the Border MSC to the
31 Serving MSC.
- 32
33 m. The Serving MSC returns a routreq to the Serving VLR with the TLDN contained
34 in the i spage and the MSCID of the Border MSC.
- 35
36 n. The Serving VLR returns the routreq to the HLR.
- 37
38 o. The HLR then sends a locreq to the Originating MSC. The locreq includes
39 routing information in the form of the TerminationList parameter, along with an
40 indication of the reason for extending the incoming call (i.e., for CD) in the
41 DMH_RedirectionIndicator parameter.
- 42
43 p. After responding to the I SPAGE, the Border MSC sends a REGNOT to the Border
44 VLR.
- 45
46 q. The Border VLR sends a REGNOT to the HLR.
- 47
48 r. The HLR cancels the registration at the visited serving system by sending a REGCANC
49 to the Serving VLR.
- 50
51 s. The Serving VLR sends a REGCANC to the Serving MSC.
- 52
53 t. The Serving MSC returns a regcanc to the Serving VLR.
- 54
55 u. The Serving VLR returns a regcanc to the HLR.
- 56
57 v. The HLR returns a regnot to the Border VLR.
- 58
59 w. The Border VLR returns a regnot to the Border MSC.
- 60

- x. The Originating MSC establishes a voice path to the Border MSC using existing interconnection protocols (e.g. SS7) and the routing information specified in the Locreq.

Note: If the Border MSC must initiate call redirection, the REDREQ is sent from the Border MSC to the Originating MSC.

6.1.8 CD Invocation with Unsolicited Page Response

This scenario describes procedures to resolve the unsolicited page response problem for MSs in border systems during call delivery.

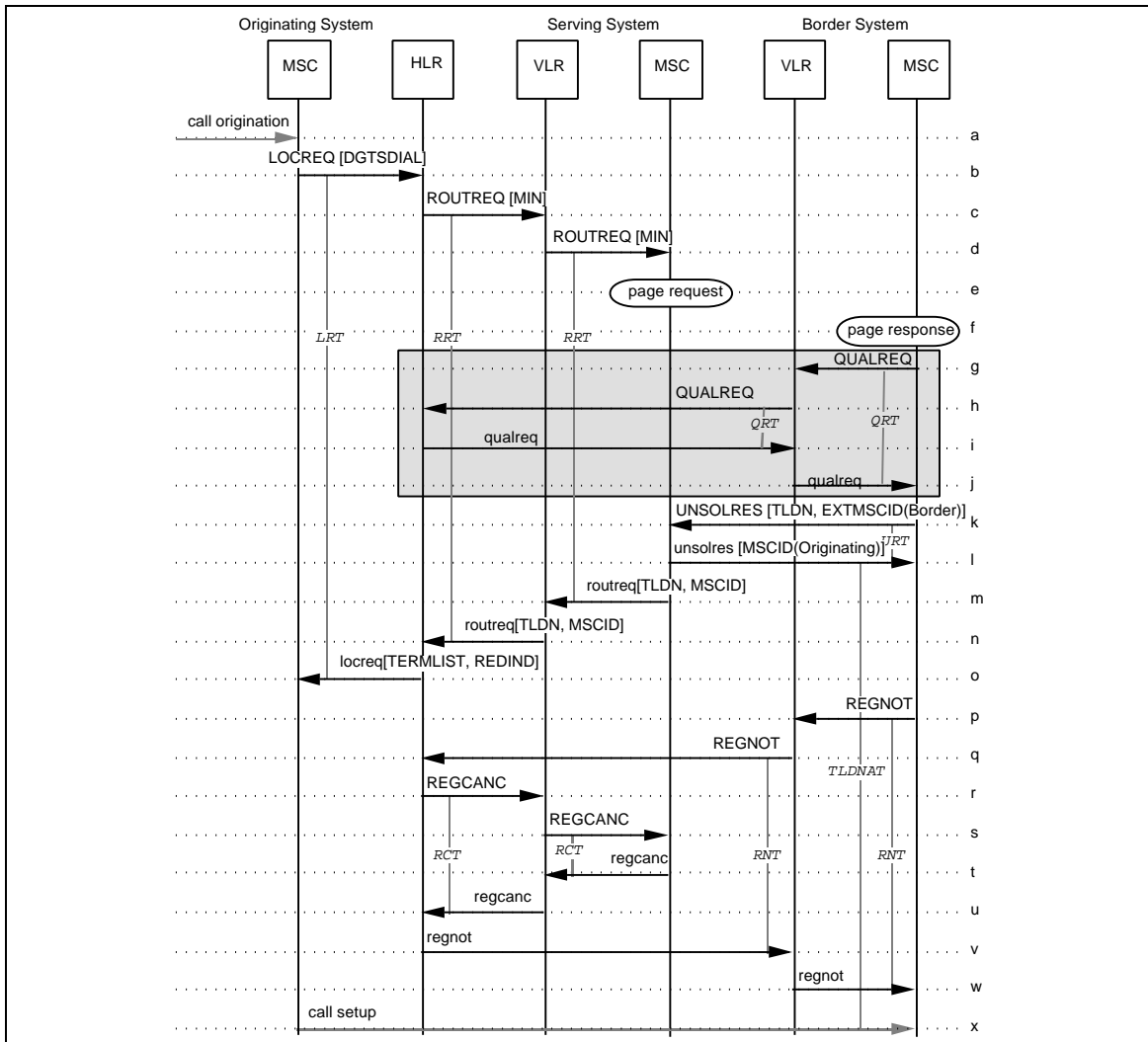

Figure 120 CD Invocation with Unsolicited Page Response

- 1
2
3
4
5
6
7
8
9
10
11
12
13
14
15
16
17
18
19
20
21
22
23
24
25
26
27
28
29
30
31
32
33
34
35
36
37
38
39
40
41
42
43
44
45
46
47
48
49
50
51
52
53
54
55
56
57
58
59
60
- a-d. Same as CD, Section 6.1.2, Steps a-d.
 - e. When the serving system receives a **ROUTREQ** it initiates paging in its serving area.
 - f. The Border MSC receives an unsolicited page response.
After the Border MSC receives a page response it can assign the MS to a voice/traffic channel. The Border MSC verifies the presence of the MS in its serving area (e.g. via SAT detection, through a voice channel audit or both).
 - g. Optionally the Border MSC sends a **QUALREQ** to the VLR indicating Border Access.
 - h. If the service profile of the MS is unknown to the VLR, it sends a **QUALREQ** to the HLR associated with the MS.
 - i. The HLR sends a **qual req** to the Border MSC's VLR, including the MS's service profile information.
 - j. The VLR sends a **qual req** to the Border MSC, including the MS's service profile information.
If the MS is authenticable, optionally authenticate it using a control channel (i.e., as in 5.4.3), or a voice channel (i.e., as in 5.4.4).
 - k. The Border MSC then allocates a routing alias (TLDN) and sends an **UNSOLRES** to one or more neighboring MSC's.
When the Serving MSC receives this **UNSOLRES**, it stops the paging process.
 - l. The Serving MSC then responds with the **unsol res** sent to the Border MSC.
- m-x. Same as CD, Section 6.1.7, Steps m-x.

6.1.9 TLDN Call Arrival with Intersystem Paging

This scenario describes TLDN Call Arrival at the serving system involving intersystem paging from the serving system to border systems.

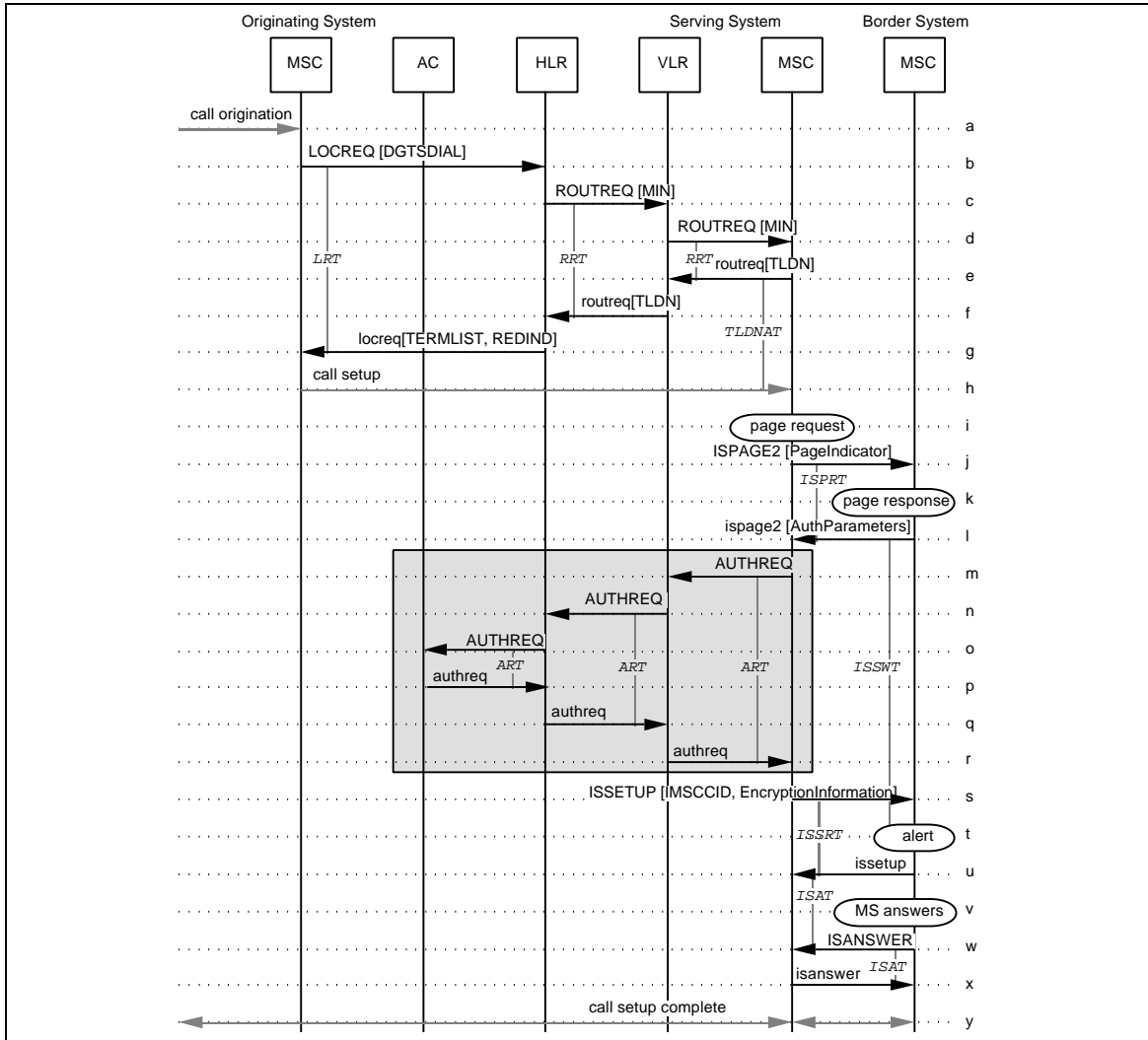

Figure 121 TLDN Call Arrival with Intersystem Paging

1
2
3
4
5
6
7
8
9
10
11
12
13
14
15
16
17
18
19
20
21
22
23
24
25
26
27
28
29
30
31
32
33
34
35
36
37
38
39
40
41
42
43
44
45
46
47
48
49
50
51
52
53
54
55
56
57
58
59
60

- a-d. Same as CD, Section 6.1.2, Steps a-d.
- e-h. Same as CD, Section 6.1.2, Steps g-j, respectively.
- i-j. Before initiating local paging, at the time of local page initiation or after first page time-out, the Serving MSC may send an **I SPAGE2** to one or more bordering MSCs according to its “topographical map” with a parameter indicating an area where the subscriber’s presence was last detected and a parameter indicating whether to page or just listen for an unsolicited page response.

The Border MSC that receives the **I SPAGE2** may initiate paging (i.e., if directed).

- k. If a page response is then received at the Border MSC, it assigns the MS to a voice/traffic channel. The Border MSC further confirms the MS’s presence (e.g., via SAT detection, through a voice channel audit or both).
- l. When the Border MSC assigns the MS to a voice/traffic channel, the Border MSC sends an **i spage2** to the Serving MSC. If authentication is to be performed, the **i spage2** contains the appropriate authentication parameters received from the MS.
- m. If authentication is indicated, the Serving MSC then sends an **AUTHREQ** to the VLR.
- n. The VLR may send the **AUTHREQ** to the HLR.
- o. If received, the HLR forwards the **AUTHREQ** to the AC.
- p. The AC sends an **authreq** to the HLR, including the Voice Privacy Mask (VPMASK) and Signaling Message Encryption Key (SMEKEY) associated with this system access.
- q. The HLR forwards the **authreq** to the VLR.
- r. The VLR sends the **authreq** to the serving MSC.
- s. The serving MSC sends an **I SSETUP** to the Border MSC to perform call setup actions. The **I SSETUP** contains the circuit ID of the intersystem trunk facility. The **I SSETUP** may also contain EncryptionInformation.

EncryptionInformation:		
[CDMAPLCM]	CDMAPrivateLongCodeMask. Include if available.	O
[SMEKEY]	SignalingMessageEncryptionKey. Include if available.	O
[VPMASK]	VoicePrivacyMask. Include if available.	O

- t. The Border MSC connects the path and alerts the mobile.
- u. The Border MSC then sends an **i ssetup** to the Serving MSC.
- v. The MS answers the alert.
- w. The Border MSC sends an **I SANSWER** to the Serving MSC.
- x. The Serving MSC sends an **i sanswer** to the Border MSC.
- y. The Serving MSC then connects the call path to the inter-MSC trunk to the Border MSC, completing the call setup process.

6.1.10 TLDN Call Arrival with No Page Response to Intersystem Paging

This scenario describes intersystem paging from the serving system to border systems, when a call has arrived at the serving system via a TLDN and the result is no page response from either the serving system or border system.

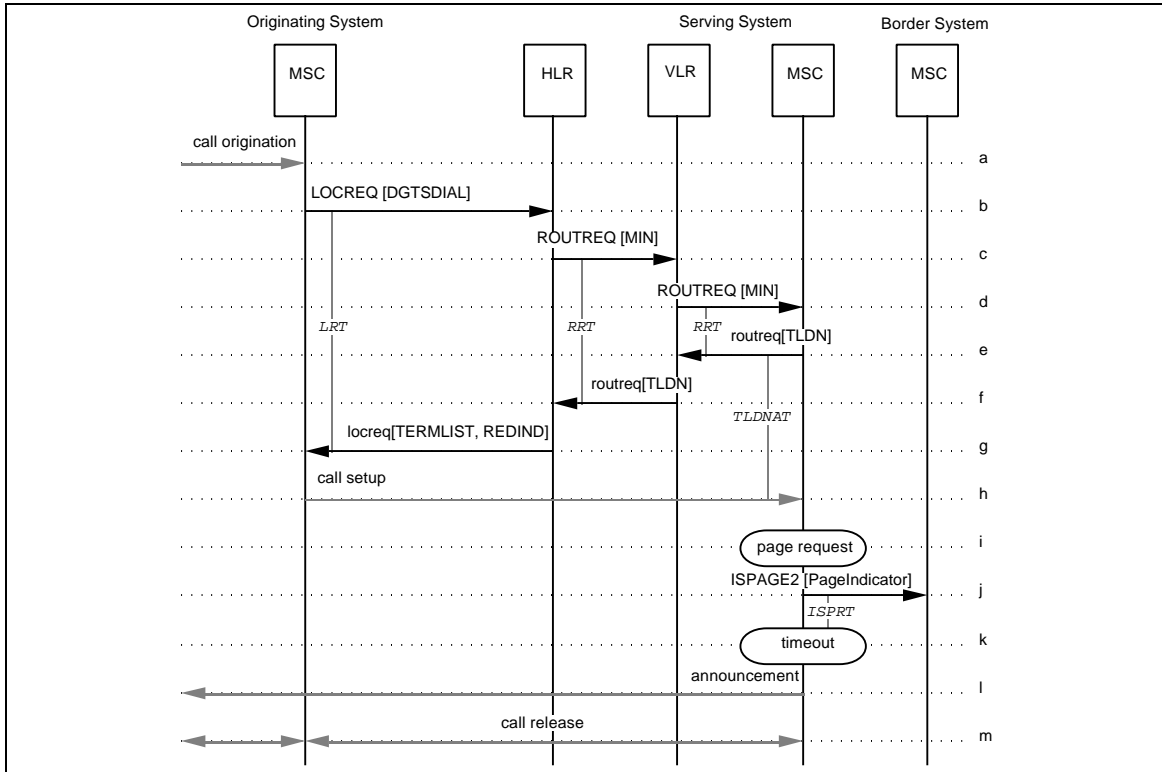

Figure 122 TLDN Call Arrival with No Page Response to Intersystem Paging

- a-j. Same as CD, Section 6.1.9, Steps a-j.
- k. The Serving MSC times out waiting for a page response from both the border system and itself.
- l. The Serving MSC provides an appropriate announcement to the calling party.
- m. The originating system releases the call.

6.1.11 TLDN Call Arrival with No Answer After Intersystem Paging, Call Release Initiated by Serving MSC

This scenario describes intersystem paging from the serving system to border systems, when a call has arrived at the Serving MSC via a TLDN and the Serving MSC time-outs waiting for answer notification from the Border MSC.

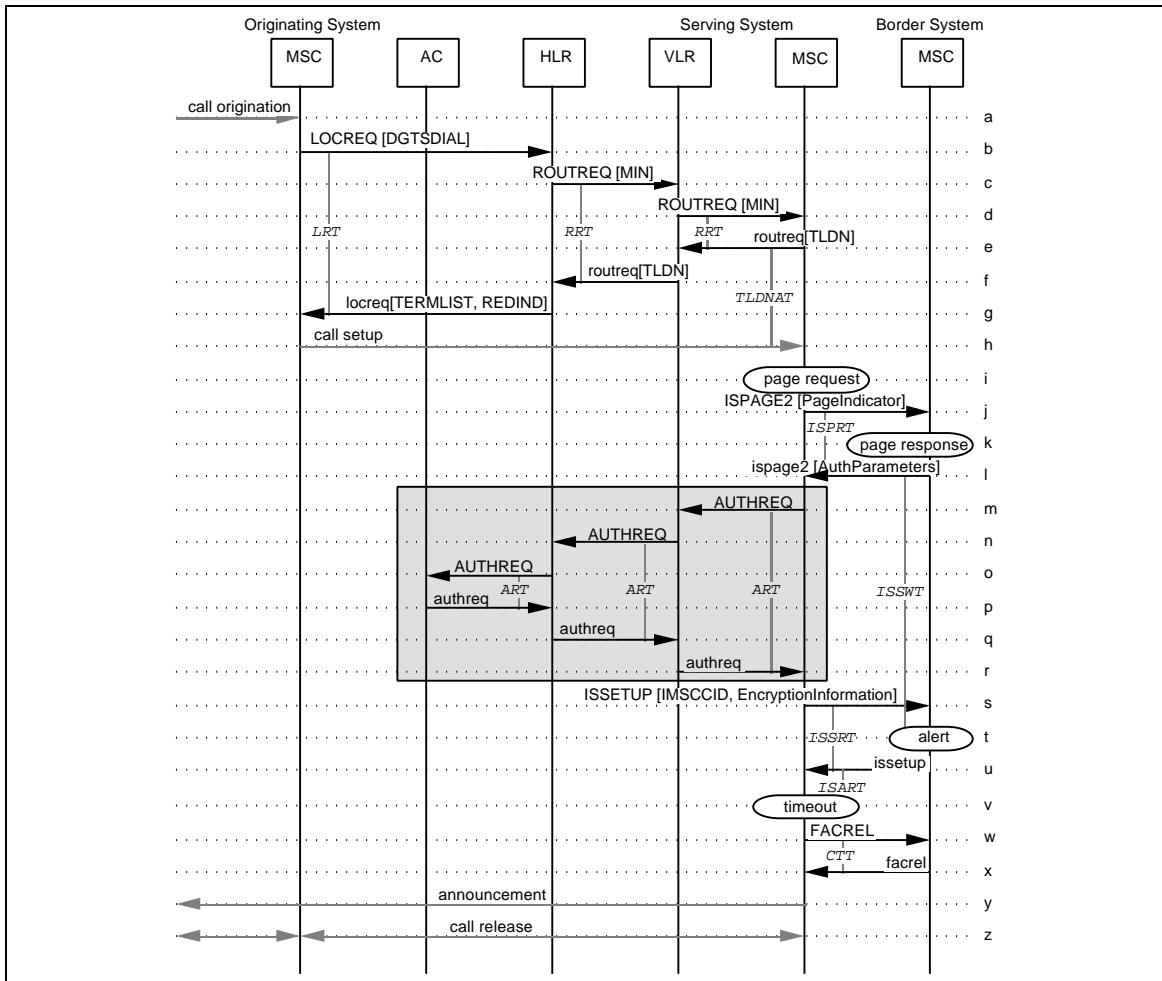

Figure 123 TLDN Call Arrival with No Answer After Paging, Call Release Initiated by Serving MSC

1
2
3
4
5
6
7
8
9
10
11
12
13
14
15
16
17
18
19
20
21
22
23
24
25
26
27
28
29
30
31
32
33
34
35
36
37
38
39
40
41
42
43
44
45
46
47
48
49
50
51
52
53
54
55
56
57
58
59
60

- a-u. Same as CD, Section 6.1.9, Steps a-u.
- v. The Serving MSC times out waiting for answer notification from the Border MSC.
- w. The Serving MSC sends a FACREL to the Border MSC.
- x. The Border MSC sends a facrel to the Serving MSC.
- y. The Serving MSC provides an appropriate announcement to the calling party.
- z. The Serving MSC releases the call.

6.1.13 Origination in a Neighboring System

This scenario describes a Mobile Station originating a call in a neighboring system while being registered in another system (old serving system).

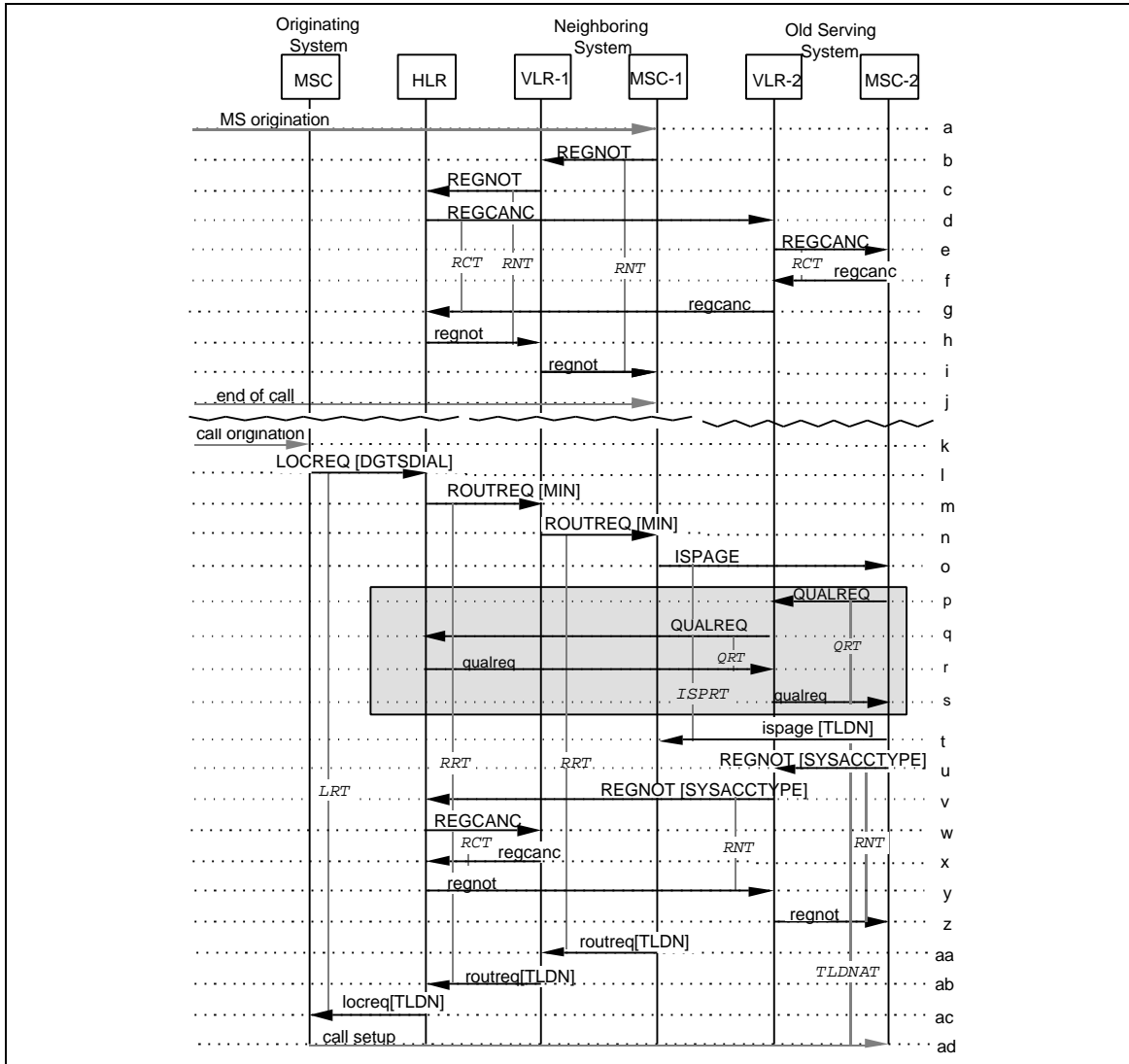

Figure 125 Origination in a Neighboring System

- 1
2
3
4
5
6
7
8
9
10
11
12
13
14
15
16
17
18
19
20
21
22
23
24
25
26
27
28
29
30
31
32
33
34
35
36
37
38
39
40
41
42
43
44
45
46
47
48
49
50
51
52
53
54
55
56
57
58
59
60
- a. The Mobile Station originates a call.
 - b. MSC-1 sends a REGNOT to its VLR with the SystemAccessType parameter set to "Call Origination".
 - c. VLR-1 forwards the REGNOT to the HLR.
 - d-g. If the mobile was previously registered elsewhere, the HLR sends a REGCANC to the Old Serving system, informing it that the MS has accessed another system.
 - h-i. The HLR acknowledges the registration.
 - j. At the end of the call, MSC-1 disables activity supervision for the MS. The MS returns to the old serving system border area.
 - k. At some future point in time, a call origination is received by the Originating MSC.
 - l. The Originating MSC sends a LOCREQ to the HLR.
 - m. The HLR sends a ROUTREQ to VLR-1, where the MS is registered.
 - n. VLR-1 then forwards the ROUTREQ to MSC-1, which initiates normal paging procedures.
 - o. Inter-system page is also initiated sending I SPAGE to MSC-2.
 - p-s. Optionally the MSC-2 may validate the MS indicating Border Access.
 - t. The MS responds to the page by MSC-2, which assigns a Temporary Local Directory Number for the call, and communicates it to MSC-1 in i spage.
 - u-v. MSC-2 initiates registration procedures for the MS sending REGNOT with the SystemAccessType parameter set to "Page Response".
 - w-x. The HLR cancels the registration at the Neighboring System.
 - y-z. The HLR acknowledges the re-registration at the Old Serving System.
 - aa-ab. The Neighboring system passes back the TLDN to the HLR in routreq.
 - ac. The HLR forwards the TLDN to the Originating MSC.
 - ad. The incoming call is routed directly to MSC-2 using the TLDN.

1
2
3
4
5
6
7
8
9
10
11
12
13
14
15
16
17
18
19
20
21
22
23
24
25
26
27
28
29
30
31
32
33
34
35
36
37
38
39
40
41
42
43
44
45
46
47
48
49
50
51
52
53
54
55
56
57
58
59
60

6.2 Call Forwarding—Busy

This section depicts the interactions between network entities in various situations related to automatic roaming and Call Forwarding— Busy (CFB). These scenarios are for illustrative purposes only.

6.2.1 CFB Variable Registration or De-Registration

The information flows required for the registration or de-registration of CFB by an authorized MS are described in Section 5.5.1.

6.2.2 CFB Demand Activation with Courtesy Call

The information flows required for the demand activation of CFB by an authorized MS, where the serving system provides the optional courtesy call to the forward-to number on CFB activation, are described in Section 5.5.2.

6.2.3 CFB Demand Activation (without Courtesy Call) or De-Activation

The information flows required for the demand activation or de-activation of CFB by an authorized MS, where the serving system does not provide the optional courtesy call to the forward-to number on CFB activation, are described in Section 5.5.1.

6.2.4 CFB Invocation

This scenario describes CFB invocation due to the served MS being busy.

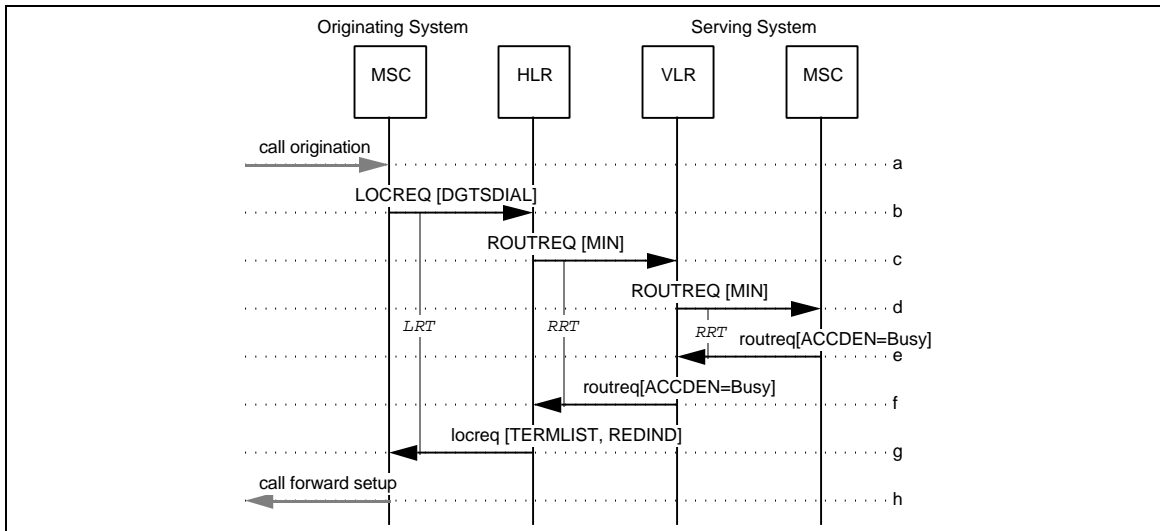

Figure 126 CFB Invocation

- a. A call origination and the dialed MS address digits (i.e., directory number) are received by the Originating MSC.
- b. The Originating MSC sends a `LOCREQ` to the HLR associated with the MS; this association is made through the dialed MS address digits (which may not be the MIN).
- c. If the dialed MS address digits are assigned to a legitimate subscriber, the HLR sends a `ROUTREQ` to the VLR where the MS is registered.
- d. The VLR then forwards the `ROUTREQ` to the current Serving MSC.
- e. In reaction to the `ROUTREQ`, the Serving MSC checks its internal data structures and determines that the MS is busy in another call. The status of the MS is returned to the VLR by the Serving MSC in the `routreq`.
- f. The VLR sends the `routreq` to the HLR.
- g. The HLR determines from the service profile that CFB is active. It sends a `locreq` to the Originating MSC providing the forward-to number and other routing information in the `TerminationList` parameter, along with an indication of the reason for extending the incoming call (i.e., for CFB) in the `DMH_RedirectionIndicator` parameter.
- h. The Originating MSC then establishes a call to the specified forward-to number.

6.2.5 CFB Invocation with Call Collision

This scenario describes call delivery to a MS that has CFB active and becomes engaged in a call at the same time that the Originating MSC is delivering a call to the Serving MSC.

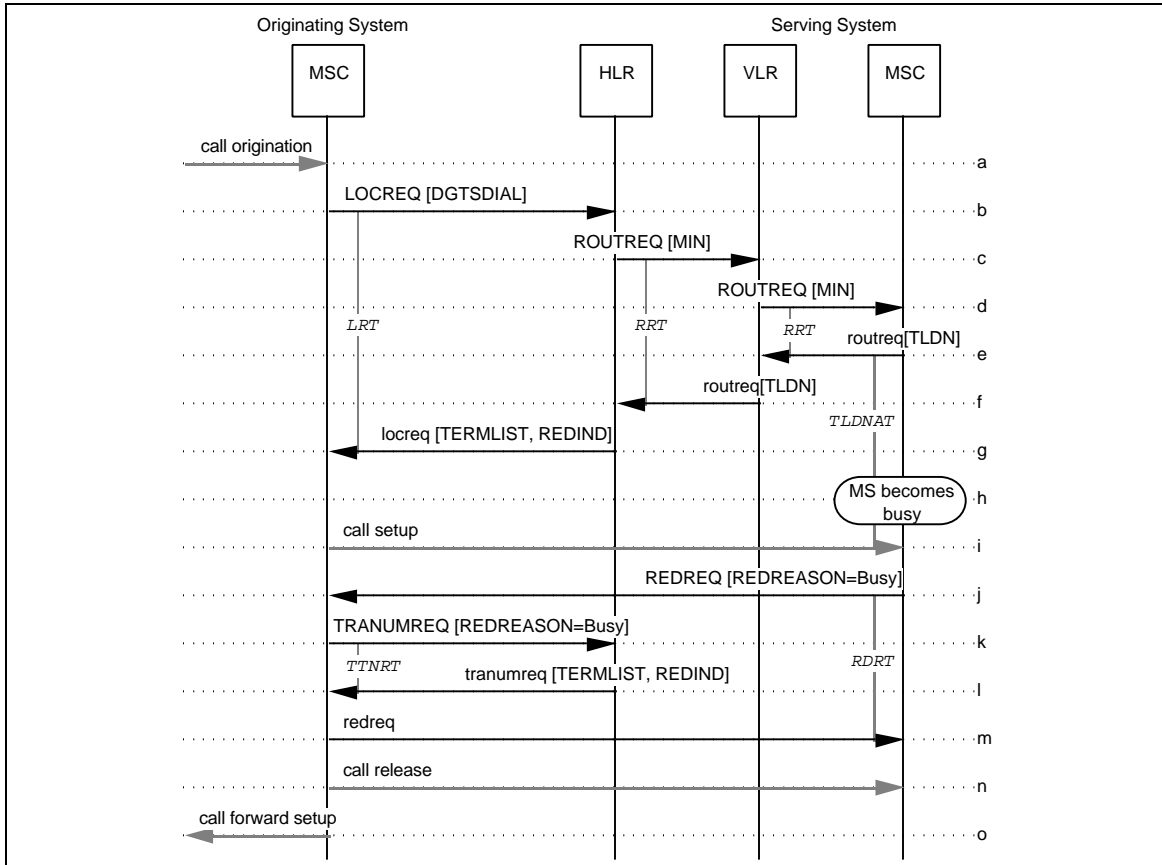

Figure 127 CFB Invocation with Call Collision

- a-d. Same as CFB, Section 6.2.4, Steps a-d.
- e. The Serving MSC allocates a TLDN (Temporary Local Directory Number) and returns this information to the VLR in the `routreq`.
- f. The VLR sends the `routreq` to the HLR.
- g. When the `routreq` is received by the HLR, it returns a `locreq` to the Originating MSC. The `locreq` includes routing information in the form of the TerminationList parameter, along with an indication of the reason for extending the incoming call (i.e., for CD) in the DMH_RedirectionIndicator parameter.
- h. Sometime after the Serving MSC sends the `routreq` back to the HLR, the MS becomes engaged in another call. This may be the result of an MS origination, a call through the local roamer port or the arrival of an inter-MSC call from a previous ROUTREQ.

1
2
3
4
5
6
7
8
9
10
11
12
13
14
15
16
17
18
19
20
21
22
23
24
25
26
27
28
29
30
31
32
33
34
35
36
37
38
39
40
41
42
43
44
45
46
47
48
49
50
51
52
53
54
55
56
57
58
59
60

- i. Upon receiving the `locreq`, the Originating MSC sets up a voice path to the Serving MSC using the protocols defined by the interconnection method.

When the inter-MSC call is received, the Serving MSC checks its internal data structures and determines that the MS is busy in another call. The Serving MSC determines from the service profile that the MS has call forwarding on busy active.
- j. The Serving MSC then sends a `REDREQ` to the Originating MSC, indicating that the call is being redirected due to a “busy” condition.
- k. The Originating MSC is able to redirect the call, therefore, it sends a `TRANUMREQ` to the HLR requesting the forward-to number appropriate for this condition from the MS’s service profile.
- l. The HLR sends the `tranumreq` to the Originating MSC, including the appropriate forward-to number in the `TerminationList` parameter, along with an indication of the reason for extending the incoming call (i.e., for CFB) in the `DMH_RedirectionIndicator` parameter.
- m. When the `tranumreq` is received from the HLR, the Originating MSC sends a `redreq` to the Serving MSC.
- n. The Originating MSC releases the voice path to the Serving MSC.
- o. The Originating MSC initiates call forwarding using the specified forward-to number.

6.3 Call Forwarding—Default

This section depicts the interactions between network entities in various situations related to automatic roaming and Call Forwarding— Default (CFD). These scenarios are for illustrative purposes only.

6.3.1 CFD Variable Registration or De-Registration

The information flows required for the registration or de-registration of CFD by an authorized MS are described in Section 5.5.1.

6.3.2 CFD Demand Activation with Courtesy Call

The information flows required for the demand activation of CFD by an authorized MS, where the serving system provides the optional courtesy call to the forward-to number on CFD activation, are described in Section 5.5.2.

Note that the activation of CFD results in the activation of call forwarding on busy, no answer, and no page response conditions at the Serving MSC.

6.3.3 CFD Demand Activation (without Courtesy Call) or De-Activation

The information flows required for the demand activation or de-activation of CFD by an authorized MS, where the serving system does not provide the optional courtesy call to the forward-to number on CFD activation, are described in Section 5.5.1.

Note that the activation of CFD results in the activation of call forwarding on busy, no answer, and no page response conditions at the Serving MSC. Likewise, the de-activation of CFD may result in the de-activation of call forwarding on busy (if CFB is not active), no answer (if CFNA is not active), and no page response (if CFNA is not active) conditions at the Serving MSC.

6.3.4 CFD Invocation with Busy

The information flows required for the invocation of CFD when the served MS is determined to be busy are the same as those for the CFB case described in Section 6.2.4; simply replace the acronym *CFB* in that description with *CFD*.

6.3.5 CFD Invocation with Call Collision

The information flows required for the invocation of CFD when the served MS becomes engaged in a call at the same time that the Originating MSC is delivering a call to the Serving MSC, are the same as those for the CFB case described in Section 6.2.5; simply replace the acronym *CFB* in that description with *CFD*.

6.3.6 CFD Invocation—Immediate

This scenario describes CFD invocation due to the following causes:

- Do Not Disturb active, etc.
- MS not registered by *TIA/EIA-41* procedures.
- MS reported inactive by *TIA/EIA-41* procedures.
- Roaming with Call Delivery inactive.

In these cases, the HLR has sufficient information available to make an immediate forwarding decision, rather than directing that the call be routed to the serving system.

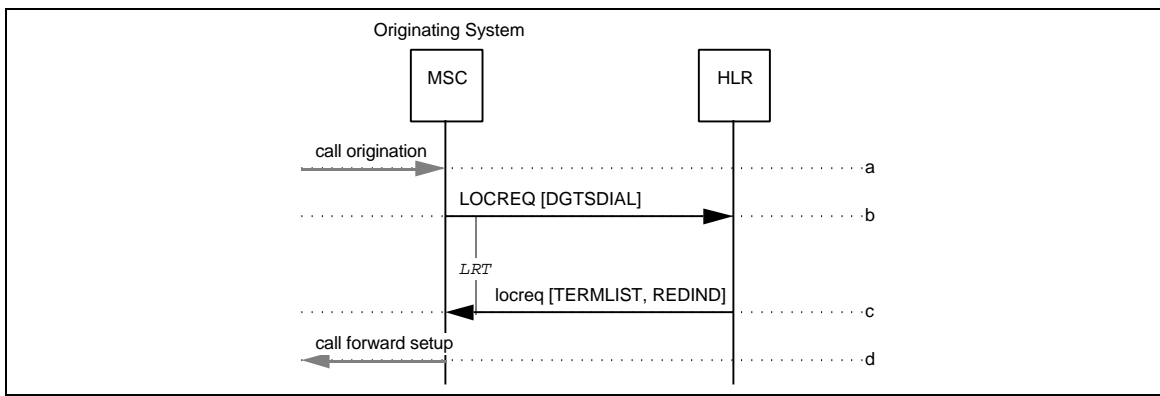

Figure 128 CFD Invocation (Immediate)

- A call origination and the dialed MS address digits (i.e., directory number) are received by the Originating MSC.
- The Originating MSC sends a **LOCREQ** to the HLR associated with the MS; this association is made through the dialed MS address digits (which may not be the MIN).
- The HLR determines from the MS's service profile that CFD is in effect and that an immediate forwarding condition exists (see above for explanation). It sends a **locreq** to the Originating MSC providing the forward-to number and other routing information in the TerminationList parameter, along with an indication of the reason for extending the incoming call (i.e., for CFD) in the DMH_RedirectionIndicator parameter.
- The Originating MSC then establishes a call to the specified forward-to number.

6.3.7 CFD Invocation with No Answer or No Response to Page

This scenario describes CFD invocation due to the MS not answering or not responding to page.

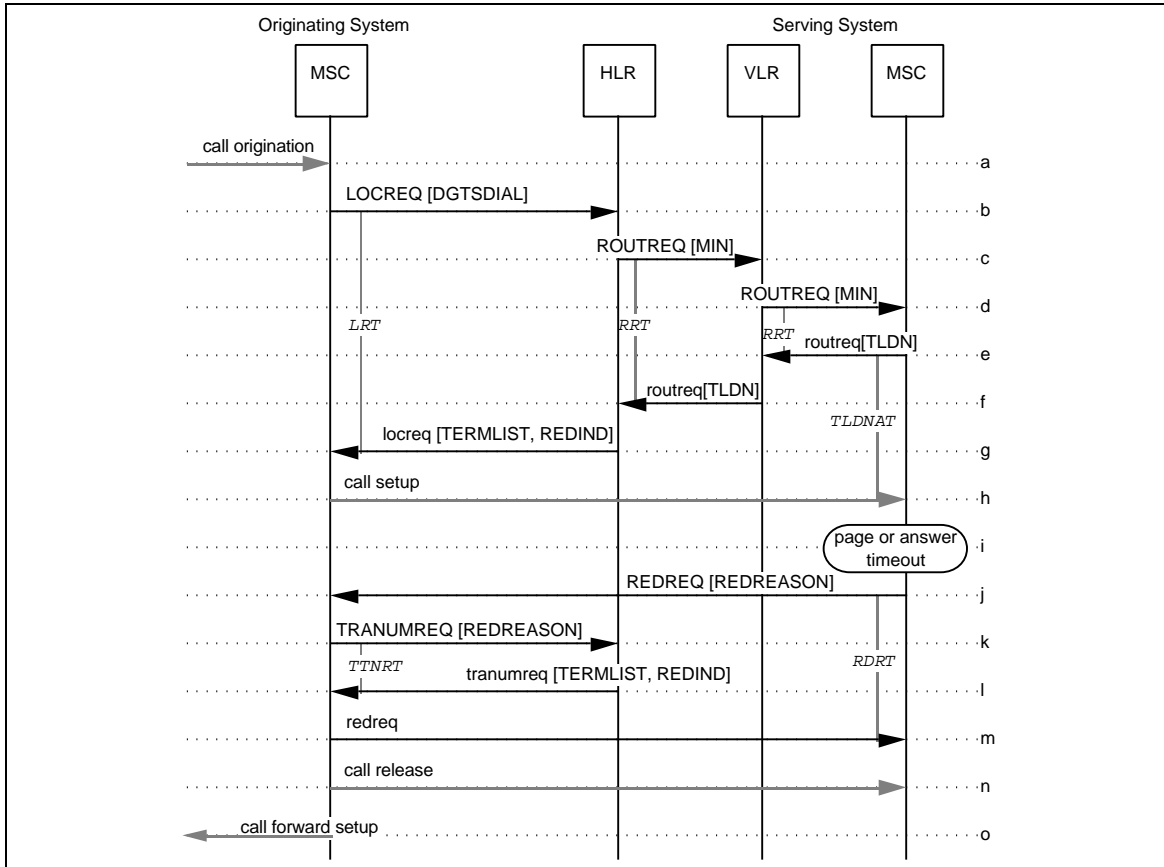

Figure 129 CFD Invocation with No Answer or No Response to Page

- 1
- 2
- 3
- 4 a. A call origination and the dialed MS address digits (i.e., directory number) are
- 5 received by the Originating MSC.
- 6
- 7 b. The Originating MSC sends a **LOCREQ** to the HLR associated with the MS; this
- 8 association is made through the dialed MS address digits (which may not be the MIN).
- 9
- 10 c. If the dialed MS address digits are assigned to a legitimate subscriber, the HLR sends
- 11 a **ROUTREQ** to the VLR where the MS is registered.
- 12
- 13 d. The VLR then forwards the **ROUTREQ** to the current Serving MSC.
- 14
- 15 e. The Serving MSC allocates a **TLDN** (Temporary Local Directory Number) and
- 16 returns this information to the VLR in the **roureq**.
- 17
- 18 f. The VLR sends the **roureq** to the HLR.
- 19
- 20 g. When the **roureq** is received by the HLR, it returns a **locreq** to the Originating
- 21 MSC. The **locreq** includes routing information in the form of the **TerminationList**
- 22 parameter, along with an indication of the reason for extending the incoming call (i.e.,
- 23 for CD) in the **DMH_RedirectionIndicator** parameter.
- 24
- 25 h. Upon receiving the **locreq**, the Originating MSC sets up a voice path to the Serving
- 26 MSC using the protocols defined by the interconnection method.
- 27
- 28 i. When the inter-MSC call is received at the Serving MSC, the MS is paged and, if a
- 29 page response is received, subsequently alerted. If the MS fails to respond to the
- 30 page or does not answer after alerting, the Serving MSC determines from the service
- 31 profile that the MS has call forwarding active on no answer or no response to page
- 32 conditions.
- 33
- 34 j. The Serving MSC sends a **REDREQ** to the Originating MSC, indicating that the call is
- 35 being redirected due to a *no answer* or *no page response* condition.
- 36
- 37 k. The Originating MSC is able to redirect the call, therefore, it sends a **TRANUMREQ** to
- 38 the HLR requesting the forward-to number appropriate for this condition from the
- 39 MS's service profile.
- 40
- 41 l. The HLR sends the **tranumreq** to the Originating MSC, including the appropriate
- 42 forward-to number in the **TerminationList** parameter, along with an indication of the
- 43 reason for extending the incoming call (i.e., for **CFD**) in the
- 44 **DMH_RedirectionIndicator** parameter.
- 45
- 46 m. When the **tranumreq** is received from the HLR, the Originating MSC sends a
- 47 **redreq** to the Serving MSC.
- 48
- 49 n. The Originating MSC releases the inter-MSC call.
- 50
- 51 o. The Originating MSC initiates call forwarding using the specified forward-to number.
- 52
- 53 As described in **CFB**, Section 6.2.5, the Serving MSC may choose to redirect the call
- 54 if it cannot be redirected by the Originating MSC. The Serving MSC should,
- 55 however, always attempt to have the call redirected by the Originating MSC in order
- 56 to minimize resource usage.
- 57
- 58
- 59
- 60

6.4 Call Forwarding—No Answer

This section depicts the interactions between network entities in various situations related to automatic roaming and Call Forwarding— No Answer (CFNA). These scenarios are for illustrative purposes only.

6.4.1 CFNA Variable Registration or De-Registration

The information flows required for the registration or de-registration of CFNA by an authorized MS are described in Section 5.5.1.

6.4.2 CFNA Demand Activation with Courtesy Call

The information flows required for the demand activation of CFNA by an authorized MS, where the serving system provides the optional courtesy call to the forward-to number on CFNA activation, are described in Section 5.5.2.

6.4.3 CFNA Demand Activation (without Courtesy Call) or De-Activation

The information flows required for the demand activation or de-activation of CFNA by an authorized MS, where the serving system does not provide the optional courtesy call to the forward-to number on CFNA activation, are described in Section 5.5.1.

6.4.4 CFNA Invocation—Immediate

This scenario describes CFNA invocation due to the following causes:

- Do Not Disturb active, etc.
- MS not registered by *TIA/EIA-41* procedures.
- MS reported inactive by *TIA/EIA-41* procedures.
- Roaming with Call Delivery inactive.

In these cases, the HLR has sufficient information available to make an immediate forwarding decision, rather than directing that the call be routed to the serving system.

The information flows required for this scenario are the same as those for the CFD case described in Section 6.3.6; simply replace the acronym *CFD* in that description with *CFNA*.

6.4.5 CFNA Invocation—Delayed

This scenario applies to the invocation of CFNA due to the following causes:

- No MS response to a page request.
- No MS or subscriber response to alerting.
- No subscriber response to Call Waiting notification.

In these cases, the HLR does not have sufficient information available to make an immediate forwarding decision; therefore, the call must be routed to the serving system, where the forwarding cause is encountered.

The information flows required for this scenario are the same as those for the CFD case described in Section 6.3.7; simply replace the acronym *CFD* in that description with *CFNA*.

1
2
3
4
5
6
7
8
9
10
11
12
13
14
15
16
17
18
19
20
21
22
23
24
25
26
27
28
29
30
31
32
33
34
35
36
37
38
39
40
41
42
43
44
45
46
47
48
49
50
51
52
53
54
55
56
57
58
59
60

6.5 Call Forwarding—Unconditional

This section depicts the interactions between network entities in various situations related to automatic roaming and Call Forwarding— Unconditional (CFU). These scenarios are for illustrative purposes only.

6.5.1 CFU Variable Registration or De-Registration

The information flows required for the registration or de-registration of CFU by an authorized MS are described in Section 5.5.1.

6.5.2 CFU Demand Activation with Courtesy Call

The information flows required for the demand activation of CFU by an authorized MS, where the serving system provides the optional courtesy call to the forward-to number on CFU activation, are described in Section 5.5.2.

6.5.3 CFU Demand Activation (without Courtesy Call) or De-Activation

The information flows required for the demand activation or de-activation of CFU by an authorized MS, where the serving system does not provide the optional courtesy call to the forward-to number on CFU activation, are described in Section 5.5.1.

6.5.4 CFU Invocation with Alert

This scenario describes CFU invocation, along with the provision of the optional CFU alert to the served MS.

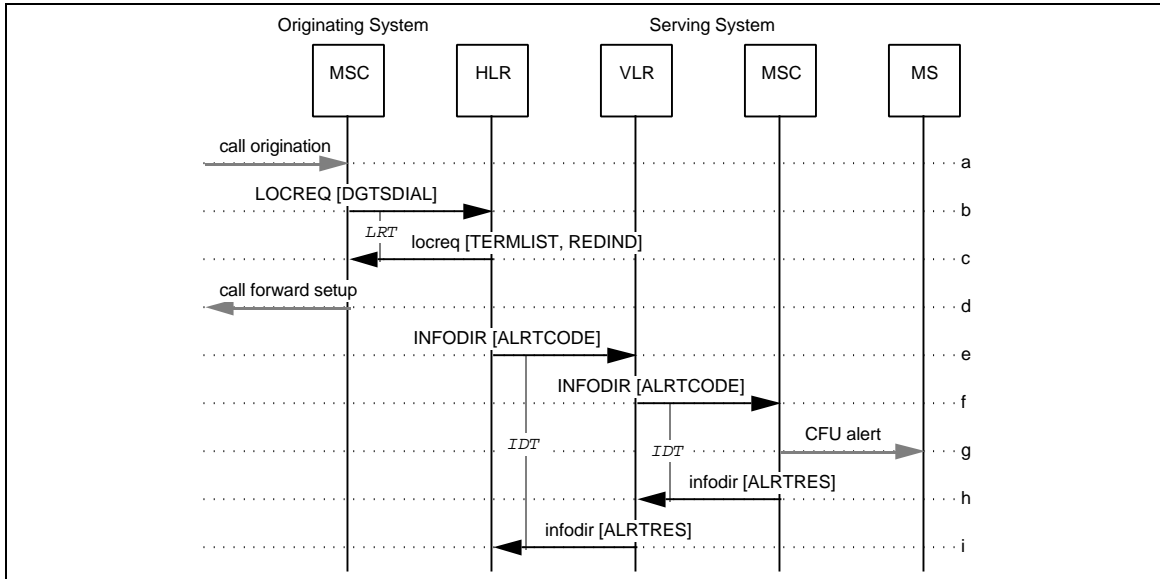

Figure 130 CFU Invocation with Alert

- a. A call origination and the dialed MS address digits (i.e., directory number) are received by the Originating MSC.
- b. The Originating MSC sends a **LOCREQ** to the HLR associated with the MS; this association is made through the dialed MS address digits (which may not be the MIN).
- c. The HLR determines from the MS's service profile that CFU is active. It sends a **lcreq** to the Originating MSC providing the forward-to number and other routing information in the TerminationList parameter, along with an indication of the reason for extending the incoming call (i.e., for CFU) in the DMH_RedirectionIndicator parameter.
- d. The Originating MSC then establishes a call to the specified forward-to number.
- e. If the HLR determines that the MS should be informed that a call has been forwarded unconditionally, it sends an **INFODIR** to the VLR where the MS is registered.
- f. The VLR directs the Serving MSC to alert the MS by sending an **INFODIR** to the Serving MSC.
- g. The Serving MSC alerts the MS, if idle, via the alerting method specified AlertCode parameter in the received **INFODIR**; in this case, the MSC applies a single, abbreviated alert signal to the MS and waits to report paging success or failure.
- h. The Serving MSC sends an **infodir** to the VLR, including the result of the alerting action (e.g., success, not attempted due to MS busy condition).
- i. The VLR forwards the **infodir** to the HLR.

1
2
3
4
5
6
7
8
9
10
11
12
13
14
15
16
17
18
19
20
21
22
23
24
25
26
27
28
29
30
31
32
33
34
35
36
37
38
39
40
41
42
43
44
45
46
47
48
49
50
51
52
53
54
55
56
57
58
59
60

6.6 Call Transfer

No feature-specific intersystem operations are required for the Call Transfer feature.

6.7 Call Waiting

This section depicts the interactions between network entities in various situations related to automatic roaming and Call Waiting (CW). These scenarios are for illustrative purposes only.

6.7.1 CW Demand Activation or De-Activation

The information flows required for the demand activation or de-activation of CW by an authorized MS are described in Section 5.5.1.

6.7.2 CW Demand Cancellation with Call

This scenario describes the demand cancellation of CW by an authorized MS. The cancellation occurs coincident with a call request.

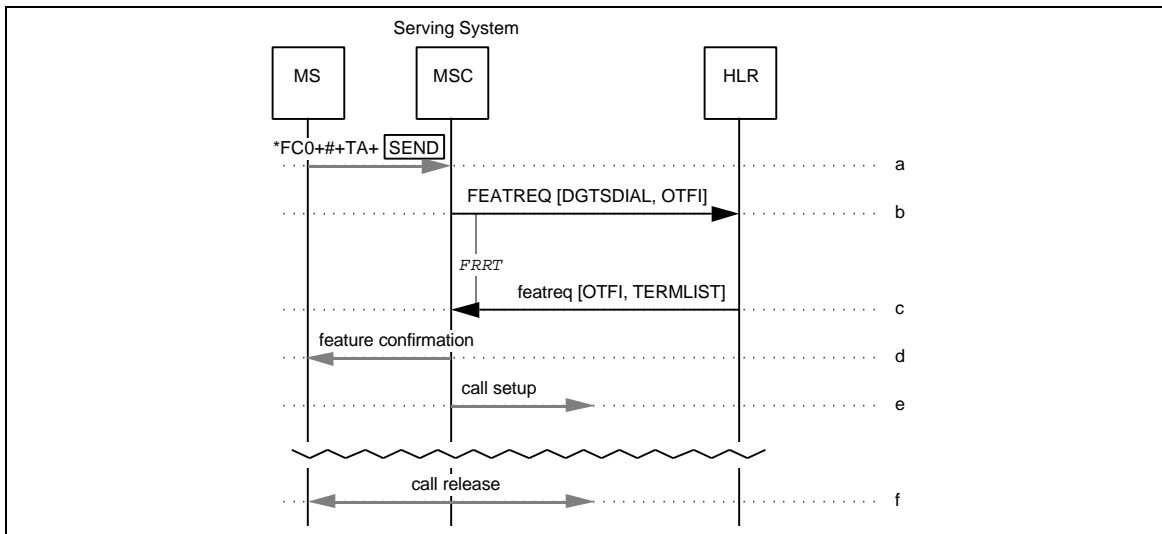

Figure 131 CW Demand Cancellation with Call

- a. A call origination and dialed digits are received by the Serving MSC. During analysis of the dialed digits, the Serving MSC detects a feature code string.
- b. The dialed digits are included in a FEATREQ and sent from the Serving MSC to the HLR associated with the MS. The Serving MSC also includes the OneTimeFeatureIndicator parameter if any of its status bits are set (i.e., if any special feature processing is active for the call).

Additional Parameters	Usage	Type
OTFI (Current Call)	Indicates special feature processing active for duration of call in progress.	O

- c. The HLR detects the authorized Cancel Call Waiting (CCW) request and sends a **featreq** to the Serving MSC. The **featreq** includes call routing information in the TerminationList parameter. It also includes the OneTimeFeatureIndicator parameter, with an indication that Call Waiting is de-activated for the call.

Additional Parameters	Usage	Type
OTFI (Current Call)	Modify feature processing for duration of call in progress = De-activate CW.	R

- d. The Serving MSC stores the CCW OneTimeFeatureIndicator, de-activates CW, and provides treatment to the served MS as indicated in the **featreq**. In this case, the treatment is to apply feature confirmation, and...
- e. ...set up the call using the call routing information in the TerminationList parameter.
- f. The CCW OneTimeFeatureIndicator (and, thus, Cancel Call Waiting) remains active until the end of the call, at which time it is discarded by the Serving MSC. The call waiting activation status then returns to its pre-call condition.

6.7.3 CW Demand Cancellation (during call)

This scenario describes the demand cancellation of CW by an authorized MS. The cancellation occurs during a call.

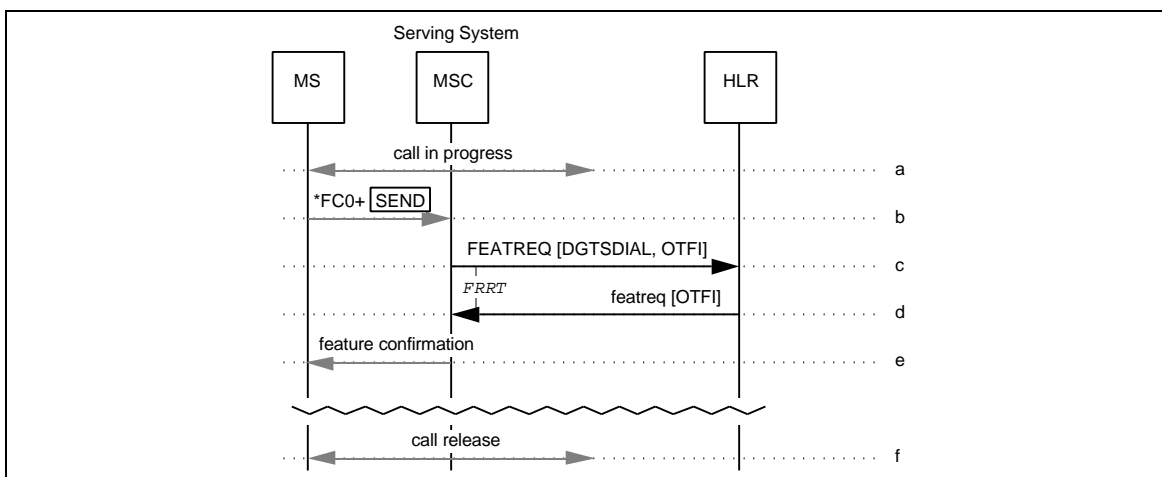

Figure 132 CW Demand Cancellation (during call)

- 1
2
3
4
5
6
7
8
9
10
11
- a. A call involving the served MS is in progress.
 - b. Dialed digits are received by the Serving MSC. During analysis of the dialed digits, the Serving MSC detects a feature code string.
 - c. The dialed digits are included in a FEATREQ and sent from the Serving MSC to the HLR associated with the MS. The Serving MSC also includes the OneTimeFeatureIndicator parameter if any of its status bits are set (i.e., if any special feature processing is active for the call).

Additional Parameters	Usage	Type
OTFI (Current Call)	Indicates special feature processing active for duration of call in progress.	O

- 12
13
14
15
16
17
18
19
20
- d. The HLR detects the authorized Cancel Call Waiting (CCW) request and sends a featreq to the Serving MSC. The featreq includes the OneTimeFeatureIndicator parameter, with an indication that Call Waiting is de-activated for the call.

Additional Parameters	Usage	Type
OTFI (Current Call)	Modify feature processing for duration of call in progress = De-activate CW.	R

- 21
22
23
24
25
26
27
28
29
30
31
32
33
34
35
36
37
38
39
40
41
42
43
44
45
46
47
48
49
50
51
52
53
54
55
56
57
58
59
60
- e. The Serving MSC stores the CCW OneTimeFeatureIndicator, de-activates CW, and provides treatment to the served MS as indicated in the ACTCODE parameter. In this case, the treatment is to apply feature confirmation.
 - f. The CCW OneTimeFeatureIndicator remains active until the end of the call, at which time it is discarded by the Serving MSC. The call waiting activation status then returns to its pre-call condition.

6.7.4 CW Invocation

This scenario describes call delivery to an MS that is currently engaged in a call but has call waiting active.

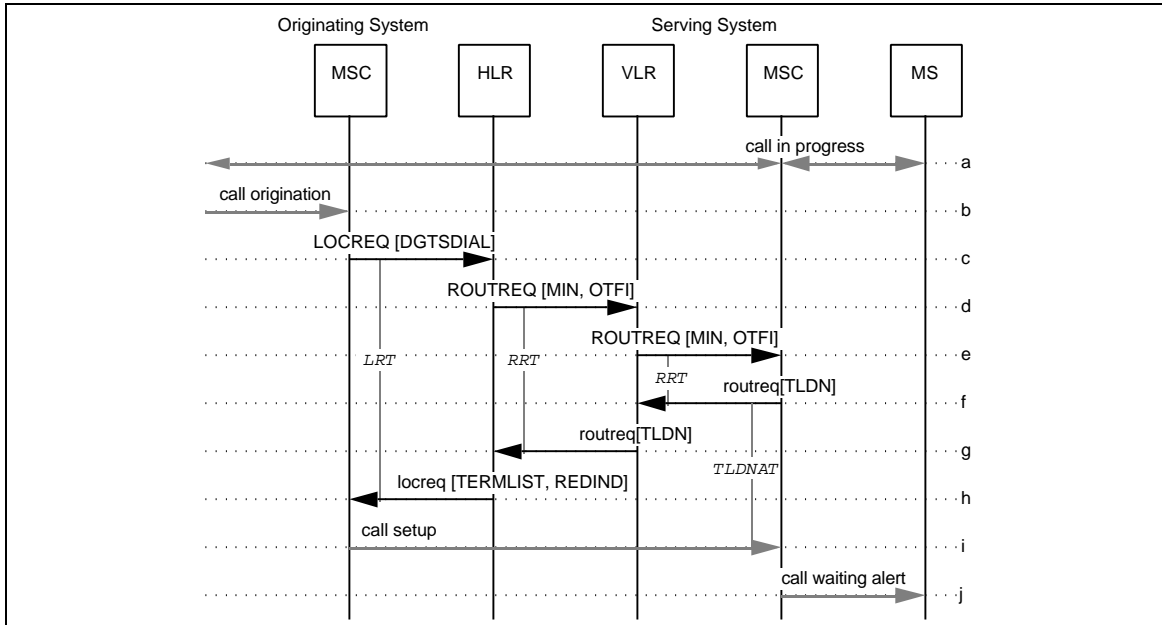

Figure 133 CW Invocation

- A call involving the served MS is in progress.
- A call origination and the dialed MS address digits (i.e., directory number) are received by the Originating MSC.
- The Originating MSC sends a **LOCREQ** to the HLR associated with the MS; this association is made through the dialed MS address digits (which may not be the MIN).
- If the dialed MS address digits are assigned to a legitimate subscriber, the HLR sends a **ROUTREQ** to the VLR where the MS is registered.
- The VLR then forwards the **ROUTREQ** to the current Serving MSC.
- In reaction to the **ROUTREQ**, the Serving MSC checks its internal data structures and determines that the MS is busy in another call but has CW active (due to MS's profile or indicated by the OTFI). Therefore, the Serving MSC allocates a TLDN (Temporary Local Directory Number) and returns this information to the VLR in the **roureq**.
- The VLR sends the **roureq** to the HLR.
- When the **roureq** is received by the HLR, it returns a **locreq** to the Originating MSC. The **locreq** includes routing information in the form of the TerminationList parameter, along with an indication of the reason for extending the incoming call (i.e., for CD) in the DMH_RedirectionIndicator parameter.

1
2
3
4
5
6
7
8
9
10
11
12
13
14
15
16
17
18
19
20
21
22
23
24
25
26
27
28
29
30
31
32
33
34
35
36
37
38
39
40
41
42
43
44
45
46
47
48
49
50
51
52
53
54
55
56
57
58
59
60

- i. Upon receiving the `locreq`, the Originating MSC sets up a voice path to the Serving MSC using the protocols defined by the interconnection method.
- j. When the (second) inter-MSC call is received at the Serving MSC, the MS receives normal call waiting treatment. Note that the Originating MSC and the HLR cannot distinguish this scenario from that of Section 6.1.2.

6.7.5 CW Interaction after Handoff

This scenario describes a busy, authorized MS for which CW is active, after intersystem handoff of the MS.

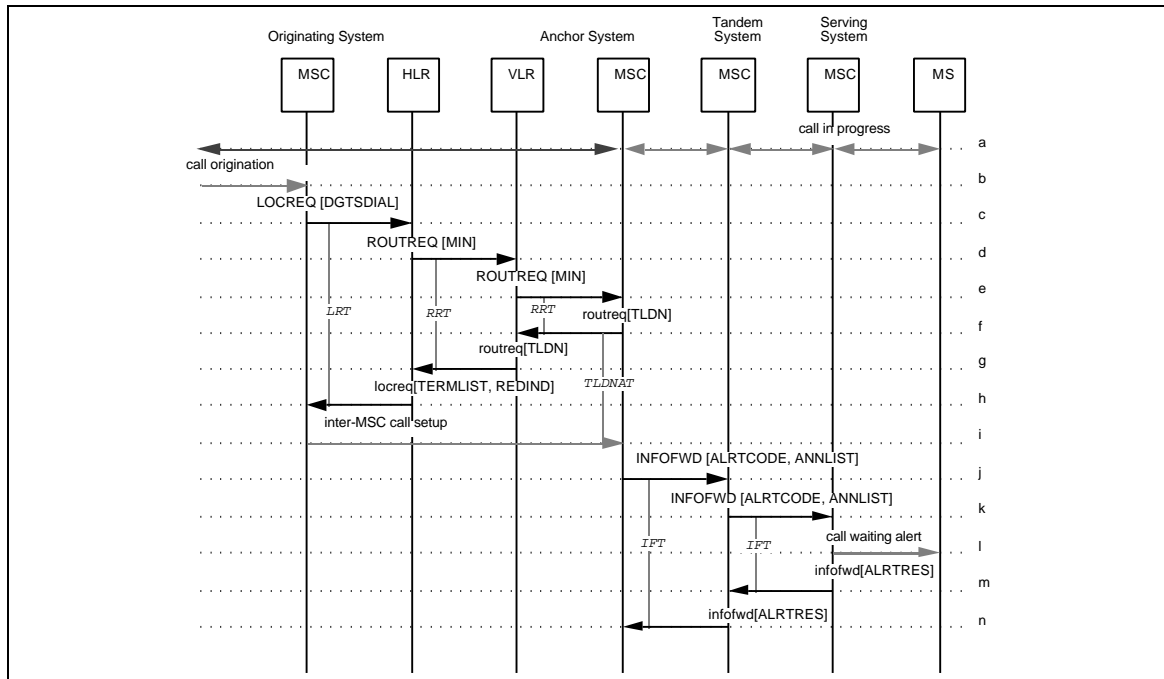

Figure 134 CW Interaction After Handoff

- a. A call involving the served MS is in progress.
- b. A call origination with a dialed MS address digits (i.e., directory number) are received by the Originating MSC.
- c. The Originating MSC sends a **LOCREQ** to the MS's HLR, including parameters based on the information received in Step-a.
- d. The HLR constructs a **ROUTREQ**, including parameters based on the information received in Step-b, and sends it to the VLR where the MS is registered.
- e. The VLR forwards the **ROUTREQ** to the current Serving MSC.
- f. In reaction to the **ROUTREQ**, the Serving MSC checks its internal data structures and determines that the MS is busy in another call but has CW active. Therefore, the Serving MSC allocates a **TLDN** (Temporary Local Directory Number) and returns this information to the VLR in the **routrreq**. The Serving MSC stores the received information.
- g. The VLR sends the **routrreq** to the HLR.
- h. When the **routrreq** is received by the HLR, it returns a **locreq** to the Originating MSC. The **locreq** includes routing information in the form of the TerminationList

parameter, along with an indication of the reason for extending the incoming call (i.e., for CD) in the DMH_RedirectionIndicator parameter.

- i. A voice path is then established between the Originating MSC and the Serving MSC using protocols defined by the interconnection method.¹
- j. If out-of-band signaling is to be applied at the Serving MSC, Anchor MSC then sends an INFOFWD to the Tandem MSC, including the alerting information.

Additional Parameters	Usage	Type
ALRTCODE	Type of alert signal to apply.	O
ANLIST	Indicates announcement to be played.	O

- k. The Tandem MSC adjusts the InterMSCCircuitID to identify the circuit between it and the Serving MSC, and forwards the INFOFWD to the Serving MSC.
- l. The Serving MSC alerts the MS via the alerting method specified by the AlertCode parameter in the received INFOFWD.
- m. The Serving MSC acknowledges receipt by sending an infofwd to the Tandem MSC, including the result of the alerting action in the AlertResult parameter.
- n. The Tandem MSC forwards the infofwd to the Anchor MSC. If the AlertResult indicates that the alert could not be applied, the Anchor MSC should apply call waiting tone.

¹If SS7 ISUP is used end-to-end, the IAM message can be used to deliver CNI information.

6.8 Calling Number Identification Presentation

This section depicts the interactions between network entities in various situations related to automatic roaming and Calling Number Identification Presentation (CNIP). These scenarios are for illustrative purposes only.

6.8.1 CNIP Invocation to an Idle Subscriber

This scenario describes CNIP invocation to an idle, authorized MS.

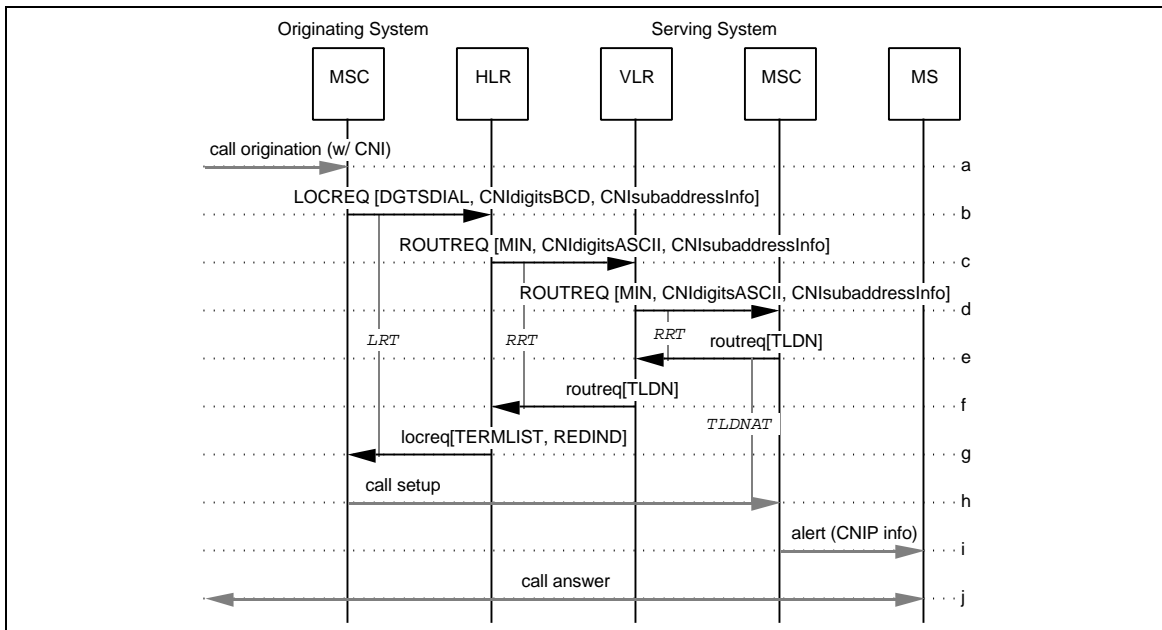

Figure 135 CNIP Invocation to an Idle Subscriber

- 1
2
3
4
5
6
7
8
9
10
11
- a. A call origination with a dialed MS address digits (i.e., directory number) are received by the Originating MSC. Also included in the call origination is calling number identification (CNI) information, which may include: one or two calling party numbers, a calling party subaddress, a redirecting number, and a redirecting subaddress.
- b. The Originating MSC sends a **LOCREQ** to the MS's HLR, including parameters based on the CNI information received in Step-a.

12
13
14
15
16
17
18
19
20
21
22
23
24
25
26

Additional Parameters	Usage	Type
CNI _{digitsBCD} :	CNI digits parameters in BCD format:	
[CallingPartyNumber-Digits1]	Calling number digits (network-provided), incl. presentation restriction information.	R
[CallingPartyNumber-Digits2]	Calling number digits (user-provided), incl. presentation restriction information.	O
[RedirectingNumber-Digits]	Redirecting number digits, incl. presentation restriction information.	O
CNI _{subaddressInfo} :	CNI subaddress information:	
[CallingPartySubaddress]	Calling number subaddress (user-provided).	O
[RedirectingSubaddress]	Redirecting number subaddress.	O

- 27
28
29
30
- c. The HLR constructs a **ROUTREQ**, including parameters based on the CNI information received in Step-b, and sends it to the VLR where the MS is registered.

31
32
33
34
35
36
37
38
39
40
41
42
43
44

Additional Parameters	Usage	Type
CNI _{digitsASCII} :	CNI digits parameters in ASCII format:	
[CallingPartyNumber-String1]	Calling number digits (network-provided), incl. presentation restriction information.	R
[CallingPartyNumber-String2]	Calling number digits (user-provided), incl. presentation restriction information.	O
[RedirectingNumber-String]	Redirecting number digits, incl. presentation restriction information.	O
CNI _{subaddressInfo} :	CNI subaddress information:	
[CallingPartySubaddress]	Calling number subaddress (user-provided).	O
[RedirectingSubaddress]	Redirecting number subaddress.	O

- 45
46
47
48
49
50
51
52
53
54
55
56
57
58
59
60
- d. The VLR forwards the **ROUTREQ** to the current Serving MSC. Parameters are as in Step-c.
- e. In reaction to the **ROUTREQ**, the Serving MSC checks its internal data structures and determines that the MS is currently idle. Therefore the Serving MSC allocates a TLDN and returns this information to the VLR in the **roureq**. The Serving MSC stores the received CNI information.
- f. The VLR sends the **roureq** to the HLR.
- g. When the **roureq** is received by the HLR, it returns a **locreq** to the Originating MSC. The **locreq** includes routing information in the form of the TerminationList parameter, along with an indication of the reason for extending the incoming call (i.e., for CD) in the DMH_RedirectionIndicator parameter.

- 1
2
3 h. A voice path is then established between the Originating MSC and the Serving MSC
4 using protocols defined by the interconnection method.¹
5
6 i. When the inter-MSC call is received at the Serving MSC, the MS is alerted.
7 Included in the alert is the appropriate Calling Number Identification Presentation
8 information.
9
10 j. When the served MS answers, the call is established.
11

12 6.8.2 CNIP Interaction with CW

13 This scenario describes CNIP invocation to a busy, authorized MS for which CW is active.
14

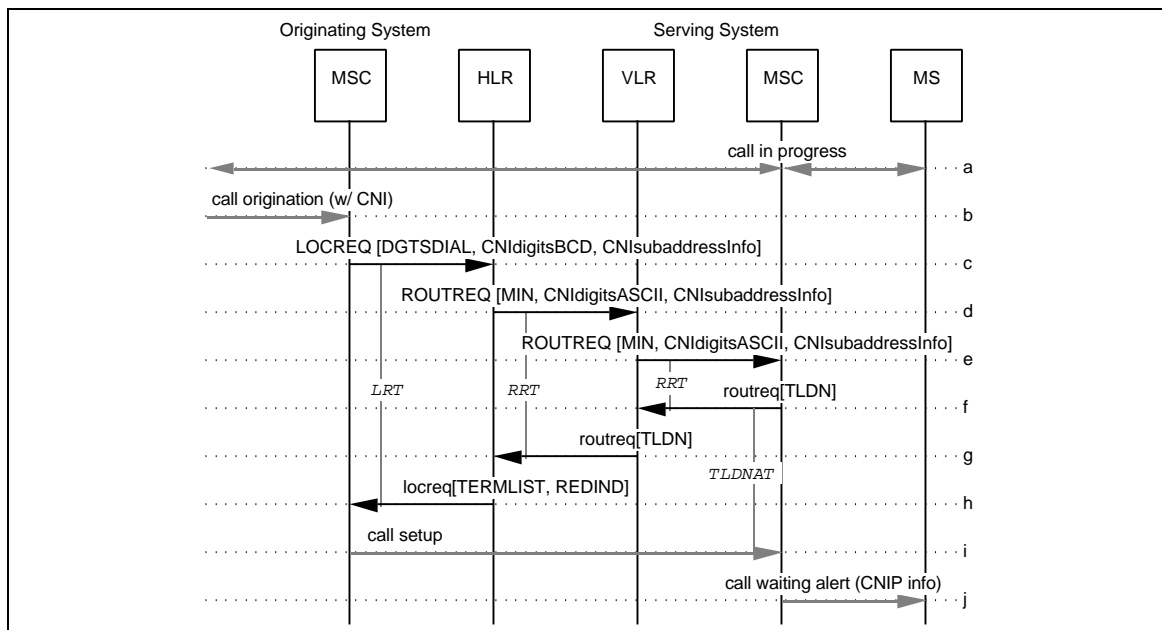

15
16
17
18
19
20
21
22
23
24
25
26
27
28
29
30
31
32
33
34
35
36
37
38 **Figure 136 CNIP Interaction with CW**

- 39
40 a. A call involving the served MS is in progress.
41
42 b-e. Same as CNIP, Section 6.8.1, Steps a-d, respectively.
43
44 f. In reaction to the ROUTREQ, the Serving MSC checks its internal data structures and
45 determines that the MS is busy in another call but has CW active. Therefore, the
46 Serving MSC allocates a TLDN (Temporary Local Directory Number) and returns this
47 information to the VLR in the routreq. The Serving MSC stores the received CNI
48 information.
49
50 g-i. Same as CNIP, Section 6.8.1, Steps f-h, respectively.
51
52
53

54
55 ¹If SS7 ISUP is used end-to-end, the IAM message can be used to deliver CNI information.
56
57
58
59
60

1
2
3
4
5
6
7
8
9
10
11
12
13
14
15
16
17
18
19
20
21
22
23
24
25
26
27
28
29
30
31
32
33
34
35
36
37
38
39
40
41
42
43
44
45
46
47
48
49
50
51
52
53
54
55
56
57
58
59
60

- j. When the (second) inter-MS-C call is received at the Serving MSC, the Serving MSC provides the MS with a CW notification. Included in the notification is the appropriate Calling Number Identification Presentation information.

6.8.3 CNIP Interaction with CW After Handoff

This scenario describes CNIP invocation to an busy, authorized MS for which CW is active, after intersystem handoff of the MS.

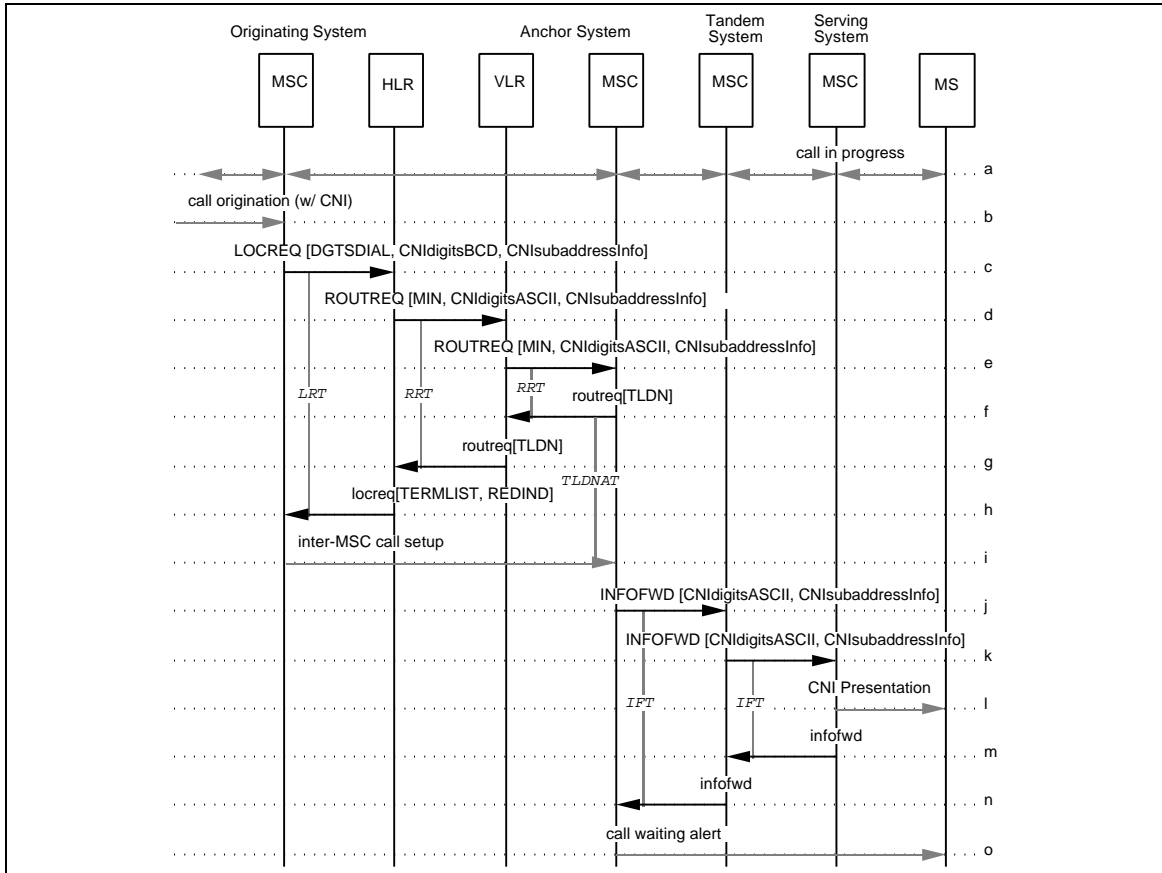

Figure 137 CNIP Interaction with Call Waiting After Handoff

- a. A call involving the served MS is in progress.
- b-e. Same as CNIP, Section 6.8.1, Steps a-d, respectively.
- f. In reaction to the ROUTREQ, the Serving MSC checks its internal data structures and determines that the MS is busy in another call but has CW active. Therefore, the Serving MSC allocates a TLDN (Temporary Local Directory Number) and returns this information to the VLR in the routreq. The Serving MSC stores the received CNI information.
- g-i. Same as CNIP, Section 6.8.1, Steps f-h, respectively.
- j. The Anchor MSC then sends an INFOFWD to the Tandem MSC, including the CNI information.

1
2
3
4
5
6
7
8
9
10
11
12
13
14
15
16
17
18
19
20
21
22
23
24
25
26
27
28
29
30
31
32
33
34
35
36
37
38
39
40
41
42
43
44
45
46
47
48
49
50
51
52
53
54
55
56
57
58
59
60

Additional Parameters	Usage	Type
CNI digits ASCII:	CNI digits parameters in ASCII format:	
[CallingPartyNumber-String1]	Calling number digits (network-provided), incl. presentation restriction information.	R
[CallingPartyNumber-String2]	Calling number digits (user-provided), incl. presentation restriction information.	O
[RedirectingNumber-String]	Redirecting number digits, incl. presentation restriction information.	O
CNI subaddress info:	CNI subaddress information:	
[CallingPartySubaddress]	Calling number subaddress (user-provided).	O
[RedirectingSubaddress]	Redirecting number subaddress.	O

- k. The Tandem MSC adjusts the InterMSCCircuitID to identify the circuit between it and the Serving MSC, and forwards the INFOFWD to the Serving MSC.
- l. The Serving MSC presents the CNI information to the served MS in an appropriate fashion.
- m. The Serving MSC acknowledges receipt by sending an infofwd to the Tandem MSC.
- n. The Tandem MSC forwards the infofwd to the Anchor MSC.
- o. When the (second) inter-MSC call is received at the Anchor MSC, the Anchor MSC provides the MS with a Call Waiting notification.

6.8.4 CNIP Interaction with CFU

This scenario describes CNIP invocation to an authorized MS for which CFU is active.

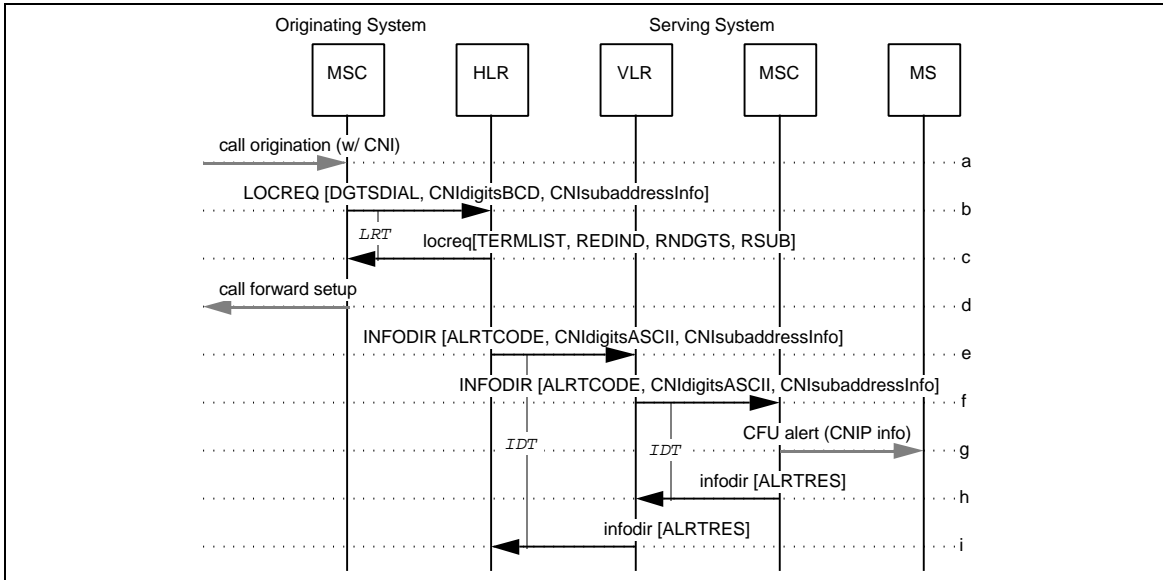

Figure 138 CNIP Interaction with CFU

1
2
3
4
5
6
7
8
9
10
11
12
13
14
15
16
17
18
19
20
21
22
23
24
25
26
27
28
29
30
31
32
33
34
35
36
37
38
39
40
41
42
43
44
45
46
47
48
49
50
51
52
53
54
55
56
57
58
59
60

a-b. Same as CNIP, Section 6.8.1, Steps a-b.

c. The HLR determines from the MS's service profile that CFU is active. It sends a `Locreq` to the Originating MSC providing the forward-to number and other routing information in the `TerminationList` parameter, along with an indication of the reason for extending the incoming call (i.e., for CFU) in the `DMH_RedirectionIndicator` parameter. It includes the MS's MIN in the `RedirectingNumberDigits` parameter. It may also include the MS's subaddress information in the `RedirectingSubaddress` parameter.

Additional Parameters	Usage	Type
RNDGTS	Redirecting number digits, set to MS's MIN.	R
RSUB	Redirecting subaddress. Include if available.	O

d. The Originating MSC then forwards the call to the specified forward-to number, including the redirecting number information.

e. If the HLR determines that the MS should be informed that a call has been forwarded unconditionally, it sends an `INFODIR` to the VLR where the MS is registered, including the CNI information.

Additional Parameters	Usage	Type
CNI digits ASCII:	CNI digits parameters in ASCII format:	
[CallingPartyNumber-String1]	Calling number digits (network-provided), incl. presentation restriction information.	R
[CallingPartyNumber-String2]	Calling number digits (user-provided), incl. presentation restriction information.	O
[RedirectingNumber-String]	Redirecting number digits, incl. presentation restriction information.	O
CNI subaddress info:	CNI subaddress information:	
[CallingPartySubaddress]	Calling number subaddress (user-provided).	O
[RedirectingSubaddress]	Redirecting number subaddress.	O

f. The VLR directs the Serving MSC to alert the served MS by sending a `INFODIR` to the Serving MSC. Parameters are as in Step -e.

g. The Serving MSC alerts the MS, if idle, via the alerting method specified `AlertCode` parameter in the received `INFODIR`; in this case, the MSC applies a single, abbreviated alert signal to the MS and waits to report paging success or failure. Included in the alert is the appropriate Calling Number Identification Presentation information.

h. The Serving MSC sends an `infodir` to the VLR, including the result of the alerting action (e.g., success, not attempted due to MS busy condition).

i. The VLR forwards the `infodir` to the HLR.

6.8.5 CNIP Interaction with CFU after Handoff

This scenario describes CNIP invocation to an authorized MS for which CFU is active, after intersystem handoff of the MS.

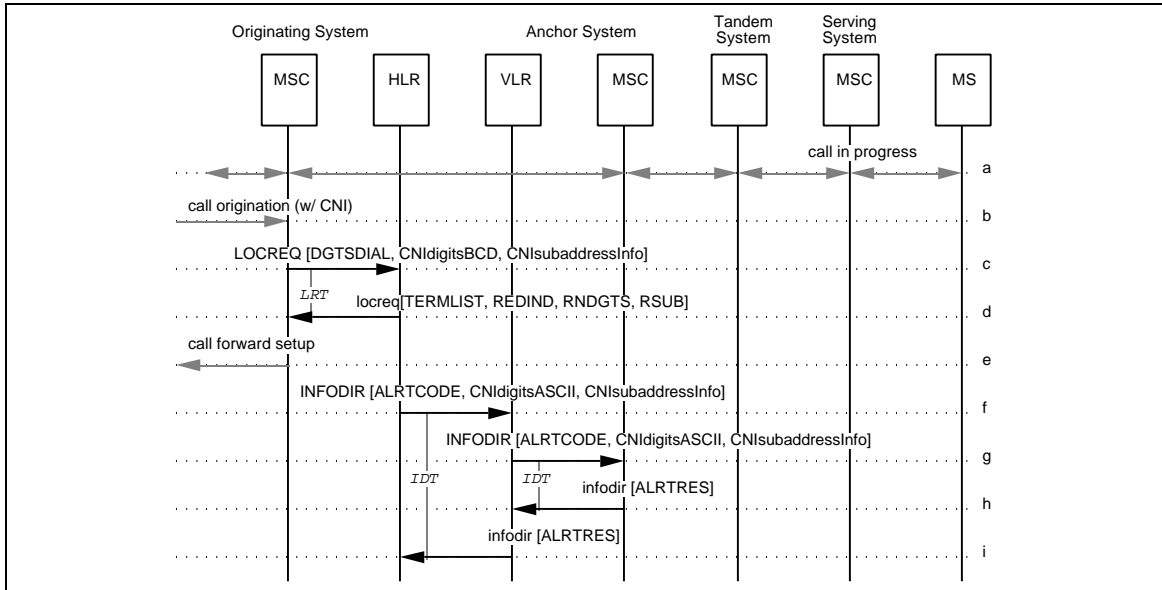

Figure 139 CNIP Interaction with CFU After Handoff

- a. A call involving the served MS is in progress.
- b-c. Same as CNIP, Section 6.8.1, Steps a-b, respectively.
- d-g. Same as CNIP, Section 6.8.4, Steps c-f, respectively.
- h. Since the MS is busy the Anchor MSC reports a paging failure; it sends an *infodir* to the VLR, including the result of the alerting action (i.e., not attempted due to MS busy condition).
- i. The VLR forwards the *infodir* to the HLR.

6.9 Calling Number Identification Restriction

This section depicts the interactions between network entities in various situations related to automatic roaming and Calling Number Identification Restriction (CNIR). These scenarios are for illustrative purposes only.

6.9.1 CNIR Temporary Activation or De-Activation with Call

This scenario describes the temporary mode activation or de-activation of CNIR by an authorized MS. The activation or de-activation occurs coincident with a call request.

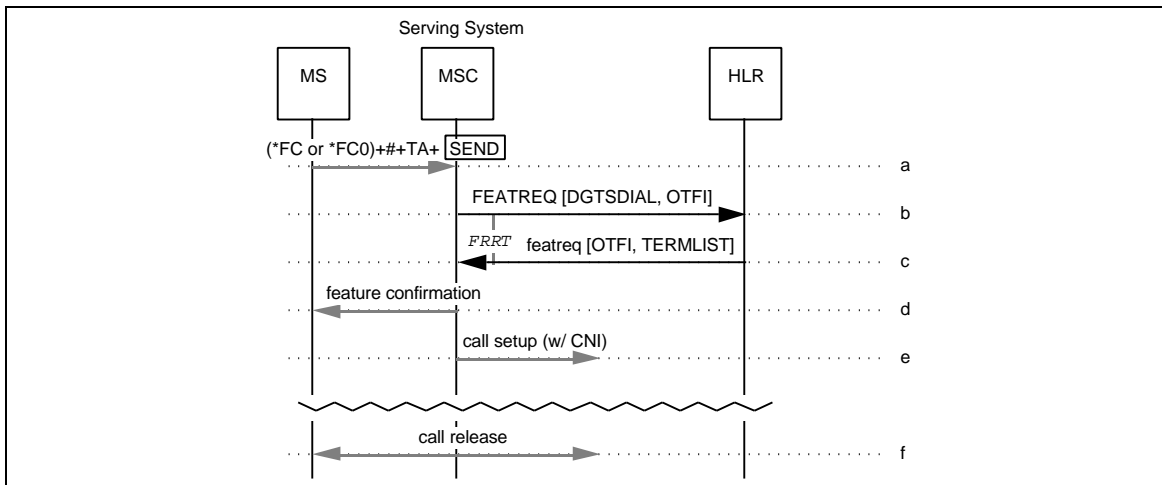

Figure 140 CNIR Temporary Activation or De-Activation with Call

- a. A call origination and dialed digits are received by the Serving MSC. During analysis of the dialed digits, the Serving MSC detects a feature code string.
- b. The dialed digits are included in a FEATREQ and sent from the Serving MSC to the HLR associated with the MS. The Serving MSC also includes the OneTimeFeatureIndicator parameter if any of its status bits are set (i.e., if any special feature processing is active for the call).

Additional Parameters	Usage	Type
OTFI (Current Call)	Indicates special feature processing active for duration of call in progress.	O

- 1
2
3
4
5
6
7
- c. The HLR detects the authorized CNIR request and sends a **featreq** to the Serving MSC. The **featreq** includes call routing information in the TerminationList parameter. It also includes the OneTimeFeatureIndicator parameter, with an indication that CNIR is either activated or de-activated for the call.

8
9
10
11

Additional Parameters	Usage	Type
OTFI (Current Call)	Modify feature processing for duration of call in progress.	R

- 12
13
14
15
16
17
18
19
20
21
22
23
24
25
26
27
28
29
30
31
32
33
34
35
36
37
38
39
40
41
42
43
44
45
46
47
48
49
50
51
52
53
54
55
56
57
58
59
60
- d. The Serving MSC stores the CNIR OneTimeFeatureIndicator, activates or de-activates CNIR, and provides treatment to the served MS as indicated in the **featreq**. In this case, the treatment is to apply feature confirmation.
- e. The Serving MSC extends the call using the call routing information in the TerminationList parameter.
- f. The CNIR OneTimeFeatureIndicator remains active until the end of the call, at which time it is discarded by the Serving MSC. The presentation restriction status then returns to its pre-call condition.

6.9.2 CNIR Interaction with CFU

This scenario describes CNIR invocation for an authorized MS for which CFU is active.

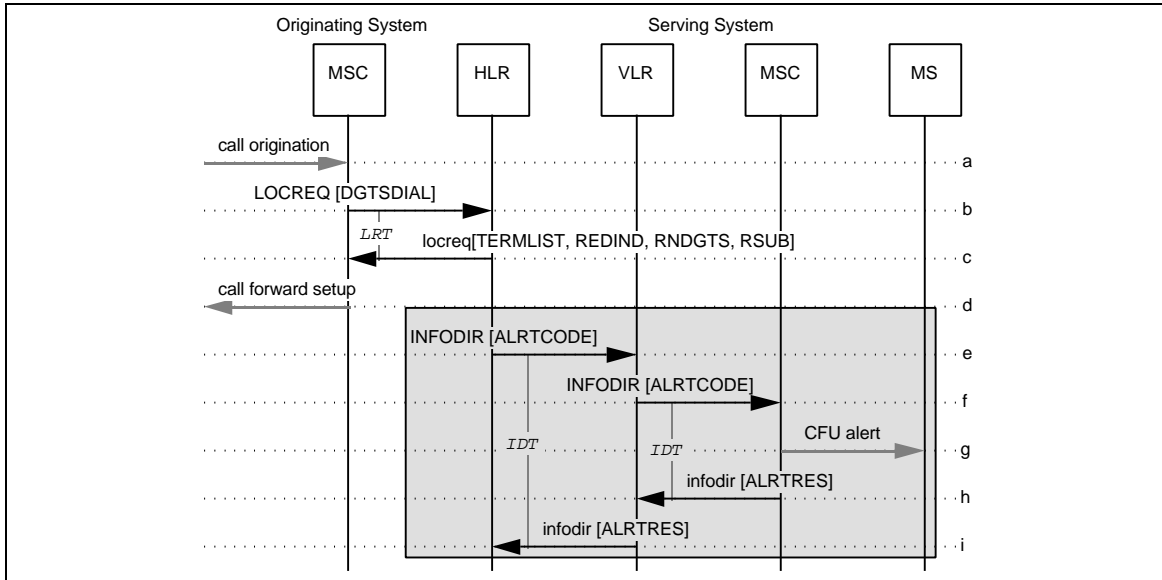

Figure 141 CNIR Interaction with CFU

1
2
3
4
5
6
7
8
9
10
11
12
13
14
15
16
17
18
19
20
21
22
23
24
25
26
27
28
29
30
31
32
33
34
35
36
37
38
39
40
41
42
43
44
45
46
47
48
49
50
51
52
53
54
55
56
57
58
59
60

- 1
2
3
4
5
6
7
8
9
10
11
12
13
14
15
16
- a. A call origination and the dialed MS address digits (i.e., directory number) are received by the Originating MSC.
 - b. The Originating MSC sends a `LOCREQ` to the MS's HLR.
 - c. The HLR determines from the MS's service profile that CFU and CNIR are active. The HLR sends a `locreq` to the Originating MSC providing the forward-to number and other routing information in the `TerminationList` parameter, along with an indication of the reason for extending the incoming call (i.e., for CFU) in the `DMH_RedirectionIndicator` parameter. It includes the MS's MIN in the `RedirectingNumberDigits` parameter, with an indication that presentation is restricted. It may also include the MS's subaddress information in the `RedirectingSubaddress` parameter.

17
18
19
20
21
22

Additional Parameters	Usage	Type
RNDGTS	Redirecting number digits, incl. presentation restriction information. Set to MS's MIN.	R
RSUB	Redirecting subaddress. Include if available.	O

- 23
24
25
26
27
28
29
30
31
32
33
34
35
36
37
38
39
40
41
42
43
44
45
46
47
48
49
50
51
52
53
54
55
56
57
58
59
60
- d. The Originating MSC then forwards the call to the specified forward-to number, including the redirecting number information with presentation restriction indication.
 - e. If the HLR determines that the MS should be informed that a call has been forwarded unconditionally, it sends an `INFODIR` to the VLR where the MS is registered.
 - f. The VLR directs the Serving MSC to alert the MS by sending an `INFODIR` to the Serving MSC.
 - g. The Serving MSC alerts the MS, if idle, via the alerting method specified `AlertCode` parameter in the received `INFODIR`; in this case, the MSC applies a single, abbreviated alert signal to the MS and waits to report paging success or failure.
 - h. The Serving MSC sends an `infodir` to the VLR, including the result of the alerting action (e.g., success, not attempted due to MS busy condition).
 - i. The VLR forwards the `infodir` to the HLR.

6.9.3 CNIR Interaction with CFNA or CFD on MS No Answer

This scenario describes CNIR invocation for an authorized MS when a no answer or no response to page condition is encountered. In addition to CNIR, the MS has CFNA or CFD (or both) active.

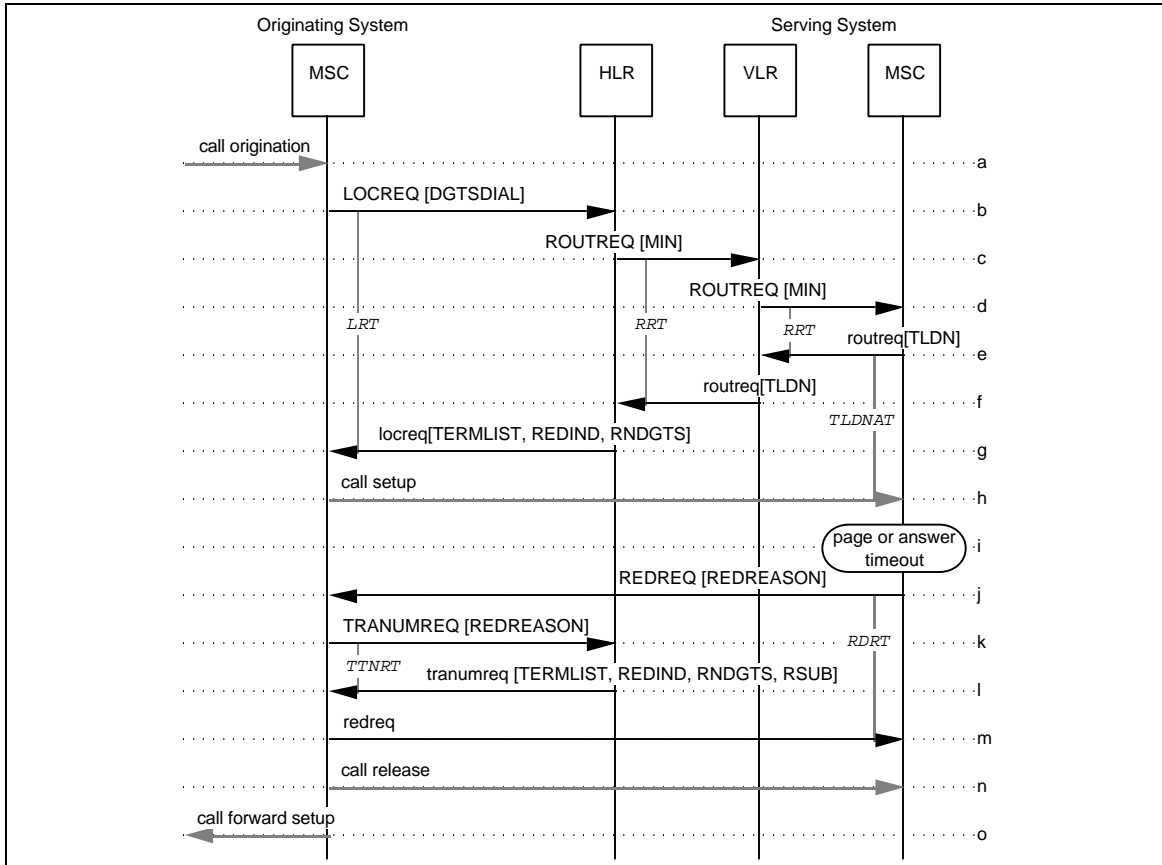

Figure 142 CNIR Interaction with CFNA or CFD on MS No Answer

- 1
2
3
4
5
6
7
8
9
10
11
12
13
14
15
16
17
18
19
20
21
22
23
24
25
26
27
28
29
30
31
32
33
34
35
36
37
38
39
40
41
42
43
44
45
46
47
48
49
50
51
52
53
54
55
56
57
58
59
60
- a. A call origination and the dialed MS address digits (i.e., directory number) are received by the Originating MSC.
 - b. The Originating MSC sends a **LOCREQ** to the HLR associated with the MS; this association is made through the dialed MS address digits (which may not be the MIN).
 - c. If the dialed MS address digits are assigned to a legitimate subscriber, the HLR sends a **ROUTREQ** to the VLR where the MS is registered.
 - d. The VLR then forwards the **ROUTREQ** to the current Serving MSC.
 - e. The Serving MSC allocates a **TLDN** (Temporary Local Directory Number) and returns this information to the VLR in the **roureq**.
 - f. The VLR sends the **roureq** to the HLR.
 - g. When the **roureq** is received by the HLR, it returns a **locreq** to the Originating MSC. The **locreq** includes routing information in the form of the **TerminationList** parameter, along with **Redirecting Digits** and an indication of the reason for extending the incoming call (i.e., for **CD**) in the **DMH_RedirectionIndicator** parameter.
 - h. Upon receiving the **locreq**, the Originating MSC sets up a voice path to the Serving MSC using the protocols defined by the interconnection method.
 - i. When the inter-MSC call is received at the Serving MSC, the MS is paged and, if a page response is received, subsequently alerted. If the MS fails to respond to the page or does not answer after alerting, the Serving MSC determines from the service profile that the MS has call forwarding active on no answer or no response to page conditions.
 - j. The Serving MSC sends a **REDREQ** to the Originating MSC, indicating that the call is being redirected due to a *no answer* or *no page response* condition.
 - k. The Originating MSC sends a **TRANUMREQ** to the HLR requesting the forward-to number appropriate for the *no answer* or *no page response* condition from the MS's service profile.
 - l. The HLR sends the **tranumreq** to the Originating MSC, including the appropriate forward-to number in the **TerminationList** parameter, along with an indication of the reason for extending the incoming call (e.g., for **CFNA**) in the **DMH_RedirectionIndicator** parameter. It includes the MS's **MIN** in the **RedirectingNumberDigits** parameter, with an indication that presentation is restricted. It may also include the MS's subaddress information in the **RedirectingSubaddress** parameter.
- | Additional Parameters | Usage | Type |
|-----------------------|---|------|
| RNDGTS | Redirecting number digits, incl. presentation restriction information. Set to MS's MIN. | R |
| RSUB | Redirecting subaddress. Include if available. | O |
- m. When the **tranumreq** is received from the HLR, the Originating MSC sends a **redreq** to the Serving MSC.
 - n. The Originating MSC releases the inter-MSC call.

1
2
3
4
5
6
7
8
9
10
11
12
13
14
15
16
17
18
19
20
21
22
23
24
25
26
27
28
29
30
31
32
33
34
35
36
37
38
39
40
41
42
43
44
45
46
47
48
49
50
51
52
53
54
55
56
57
58
59
60

- o. The Originating MSC initiates call forwarding to the specified forward-to number, including the redirecting number information with presentation restriction indication.

6.9.4 CNIR Interaction with CFB or CFD on MS Busy

This scenario describes CNIR invocation for an authorized MS when an MS busy condition is encountered. In addition to CNIR, the MS has CFB or CFD (or both) active.

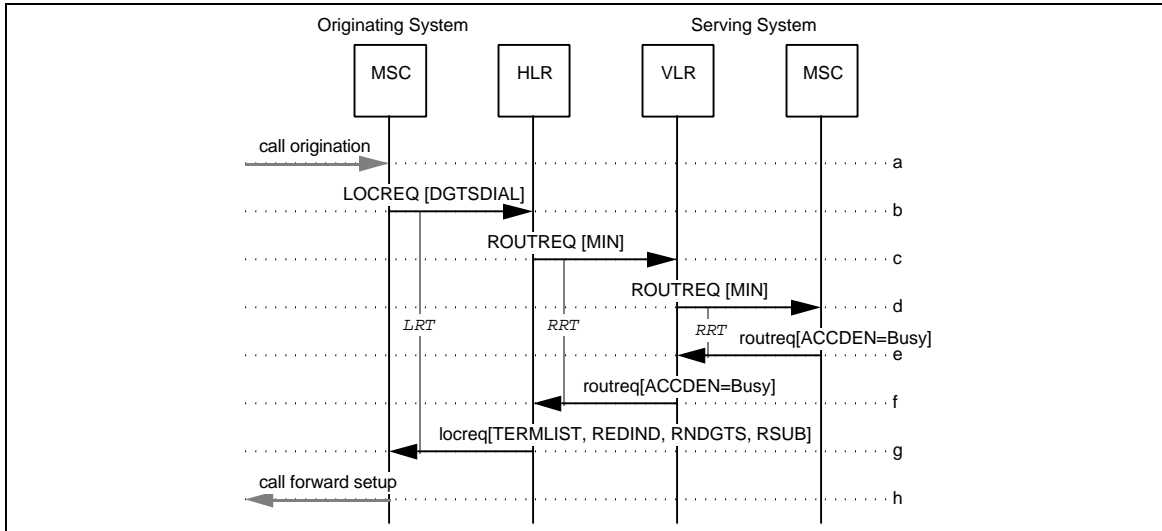

Figure 143 CNIR Interaction with CFB or CFD on MS Busy

- 1
2
3
4
5
6
7
8
9
10
11
12
13
14
15
16
17
18
19
20
21
22
23
24
25
26
27
- a. A call origination and the dialed MS address digits (i.e., directory number) are received by the Originating MSC.
 - b. The Originating MSC sends a `LOCREQ` to the HLR associated with the MS; this association is made through the dialed MS address digits (which may not be the MIN).
 - c. If the dialed MS address digits are assigned to a legitimate subscriber, the HLR sends a `ROUTREQ` to the VLR where the MS is registered.
 - d. The VLR then forwards the `ROUTREQ` to the current Serving MSC.
 - e. In reaction to the `ROUTREQ`, the Serving MSC checks its internal data structures and determines that the MS is busy in another call. The status of the MS is returned to the VLR by the Serving MSC in the `routeq`.
 - f. The VLR sends the `routeq` to the HLR.
 - g. The HLR determines from the service profile that CFB or CFD (or both) is active. It sends a `locreq` to the Originating MSC providing the forward-to number and other routing information in the `TerminationList` parameter, along with an indication of the reason for extending the incoming call (e.g., for CFB) in the `DMH_RedirectionIndicator` parameter. It includes the MS's MIN in the `RedirectingNumberDigits` parameter, with an indication that presentation is restricted. It may also include the MS's subaddress information in the `RedirectingSubaddress` parameter.

Additional Parameters	Usage	Type
RNDGTS	Redirecting number digits, incl. presentation restriction information. Set to MS's MIN.	R
RSUB	Redirecting subaddress. Include if available.	O

- 28
29
30
31
32
33
34
35
36
37
38
39
40
41
42
43
44
45
46
47
48
49
50
51
52
53
54
55
56
57
58
59
60
- h. The Originating MSC then forwards the call to the specified forward-to number, including the redirecting number information with presentation restriction indication.

6.9.5 CNIR Interaction with CFB or CFD on Call Collision

This scenario describes CNIR invocation for an authorized MS when an MS busy condition is encountered; i.e., the MS becomes engaged in a call at the same time that the Originating MSC is delivering a call to the Serving MSC. In addition to CNIR, the MS has CFB or CFD (or both) active.

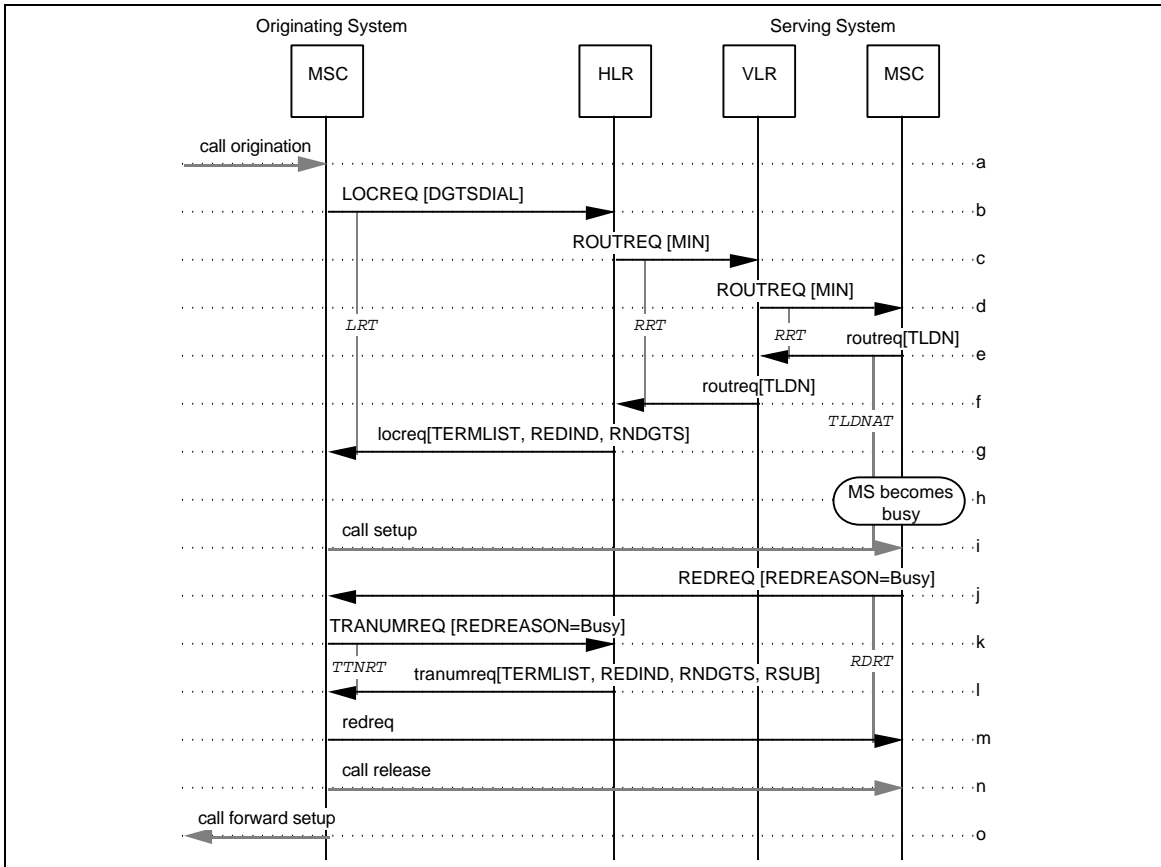

Figure 144 CNIR Interaction with CFB or CFD on Call Collision

- 1
2
3
4
5
6
7
8
9
10
11
12
13
14
15
16
17
18
19
20
21
22
23
24
25
26
27
28
29
30
31
32
33
34
35
36
37
38
39
40
41
42
43
44
45
46
47
48
49
50
51
52
53
54
55
56
57
58
59
60
- a-g. Same as CNIR, Section 6.9.2, Steps a-g.
 - h. Sometime after the Serving MSC sends the `routrreq` back to the HLR, the MS becomes engaged in another call. This may be the result of an MS origination, a call through the local roamer port or the arrival of an inter-MSC call from a previous `ROUTREQ`.
 - i. Upon receiving the `locrreq`, the Originating MSC sets up a voice path to the Serving MSC using the protocols defined by the interconnection method.
When the inter-MSC call is received, the Serving MSC checks its internal data structures and determines that the MS is busy in another call. The Serving MSC determines from the service profile that the MS has call forwarding on busy active.
 - j. The Serving MSC then sends a `REDREQ` to the Originating MSC, indicating that the call is being redirected due to a *busy* condition.
 - k. The Originating MSC sends a `TRANUMREQ` to the HLR requesting the forward-to number appropriate for the *busy* condition from the MS's service profile.
 - l. The HLR sends the `tranumreq` to the Originating MSC, including the appropriate forward-to number in the `TerminationList` parameter, along with an indication of the reason for extending the incoming call (e.g., for CFB) in the `DMH_RedirectionIndicator` parameter. It includes the MS's `MIN` in the `RedirectingNumberDigits` parameter, with an indication that presentation is restricted. It may also include the MS's subaddress information in the `RedirectingSubaddress` parameter.
- | Additional Parameters | Usage | Type |
|-----------------------|---|------|
| RNDGTS | Redirecting number digits, incl. presentation restriction information. Set to MS's <code>MIN</code> . | R |
| RSUB | Redirecting subaddress. Include if available. | O |
- m. When the `tranumreq` is received from the HLR, the Originating MSC sends a `redreq` to the Serving MSC.
 - n. The Originating MSC releases the inter-MSC call, and ...
 - o. The Originating MSC initiates call forwarding to the specified forward-to number, including the redirecting number information with presentation restriction indication.

6.10 Conference Calling

This section depicts the interactions between network entities in various situations related to automatic roaming and Conference Calling (CC). These scenarios are for illustrative purposes only.

6.10.1 CC Invocation with Call Setup Request

This scenario describes the invocation of CC by an authorized MS. The invocation occurs with a concurrent call setup request. It also illustrates how another party is added to the conference call via the entry of a feature code string by the controlling subscriber.

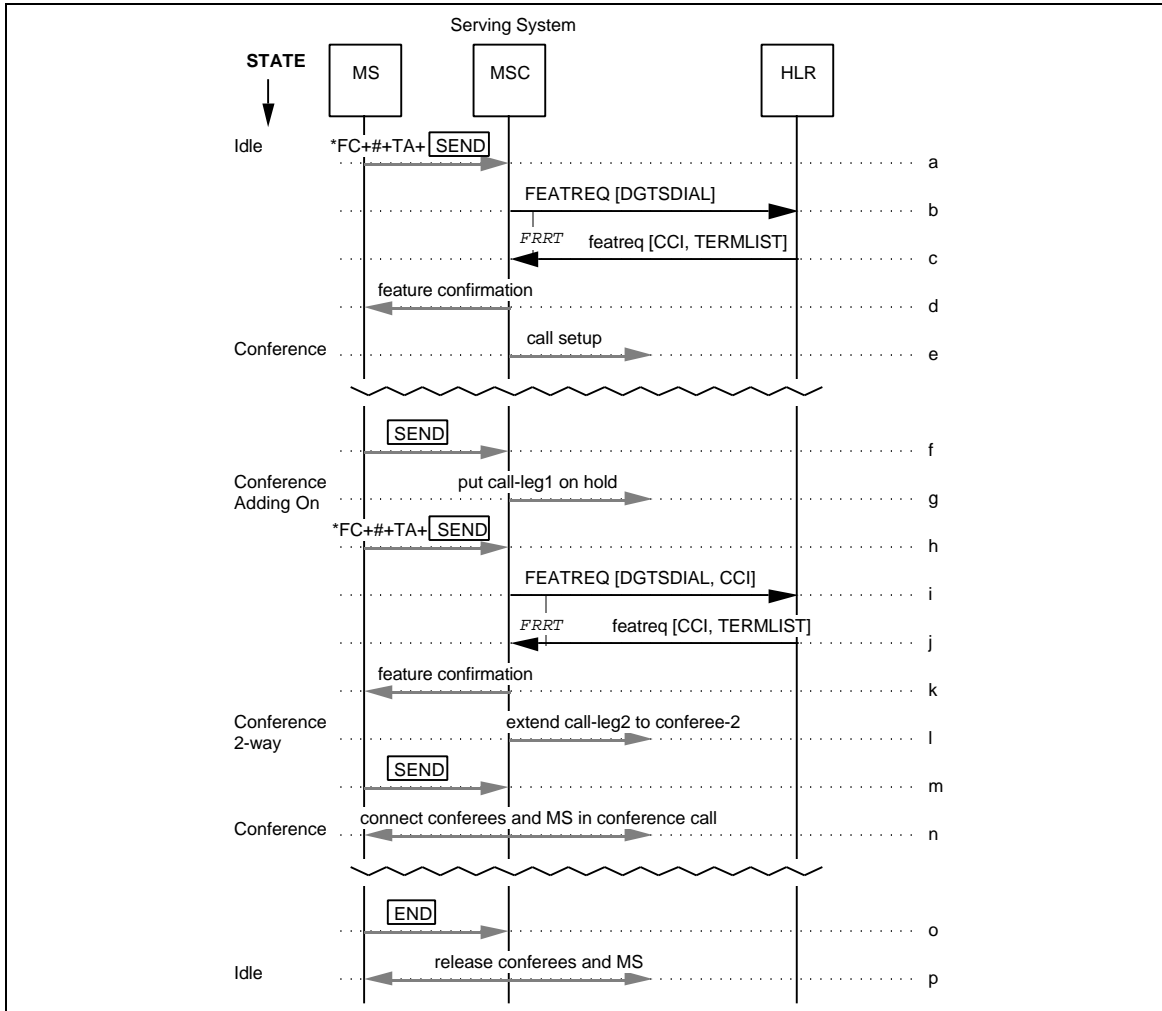

Figure 145 CC Invocation with Call Setup Request

- 1
2
3
4
5
6
7
8
9
10
11
12
- a. A call origination and dialed digits are received by the Serving MSC. During analysis of the dialed digits, the Serving MSC detects a feature code string.
 - b. The dialed digits are included in a FEATREQ and sent from the Serving MSC to the HLR associated with the MS.
 - c. The HLR detects the authorized CC request and sends a **featreq** to the Serving MSC. The **featreq** includes call routing information in the TerminationList parameter. It also includes the ConferenceCallingIndicator parameter, indicating that Conference Calling is active for the call.

13
14
15
16
17
18
19
20

Additional Parameters	Usage	Type
CCI	ConferenceCallingIndicator. Presence of this parameter indicates that the outgoing call is to be handled as a Conference Call. The parameter carries the maximum number of allowed conferees.	R

- 21
22
23
24
25
26
27
28
29
30
31
32
33
34
35
36
37
38
39
40
41
42
43
44
45
46
47
48
49
50
51
52
53
54
55
56
57
58
59
60
- d. The Serving MSC stores the ConferenceCallingIndicator information, activates conference calling, and provides treatment to the served MS as indicated in the **featreq**. In this case, the treatment is to apply feature confirmation.
 - e. The Serving MSC extends the call using the call routing information in the TerminationList parameter (call-leg-1).
 - f. MS-1 sends a flash request to the Serving MSC (i.e., presses the $\text{¥x}(\text{SEND})$ key).
 - g. The Serving MSC puts call-leg-1 on hold.
 - h. Dialed digits are received by the Serving MSC. During analysis of the dialed digits, the Serving MSC detects a feature code string.
 - i. The dialed digits are included in a FEATREQ and sent from the Serving MSC to the HLR associated with the MS. The Serving MSC also includes the ConferenceCallingIndicator parameter, indicating the number of conferees already in the call..
 - j. The HLR detects the authorized CC request and sends a **featreq** to the Serving MSC. The **featreq** includes call routing information in the TerminationList parameter. It also includes the ConferenceCallingIndicator parameter, indicating that Conference Calling is active for the call and the maximum number of allowed conferees.
 - k. The Serving MSC provides treatment to the served MS as indicated in the **featreq**. In this case, the treatment is to apply feature confirmation.
 - l. The Serving MSC extends the call using the call routing information in the TerminationList parameter (call-leg-2).
 - m. MS-1 sends a Flash Request to the Serving MSC (i.e., presses the $\text{¥x}(\text{SEND})$ key).
 - n. The Serving MSC connects the served MS, the held conferee and the new party into a conference call.
 - o. MS-1 sends a Disconnect Request to the Serving MSC (i.e., presses the $\text{¥x}(\text{END})$ key).

1
2
3
4
5
6
7
8
9
10
11
12
13
14
15
16
17
18
19
20
21
22
23
24
25
26
27
28
29
30
31
32
33
34
35
36
37
38
39
40
41
42
43
44
45
46
47
48
49
50
51
52
53
54
55
56
57
58
59
60

- p. The Serving MSC releases the served MS and conferees and discards the ConferenceCallingIndicator information.

6.10.2 CC Add Party (Without Feature Code Entry)

This scenario describes the invocation of CC by an authorized MS. The invocation occurs with a concurrent call setup request. It also illustrates how another party is added to the conference call via the entry of a termination address only (i.e., no feature code is entered when adding the second party) by the controlling subscriber.

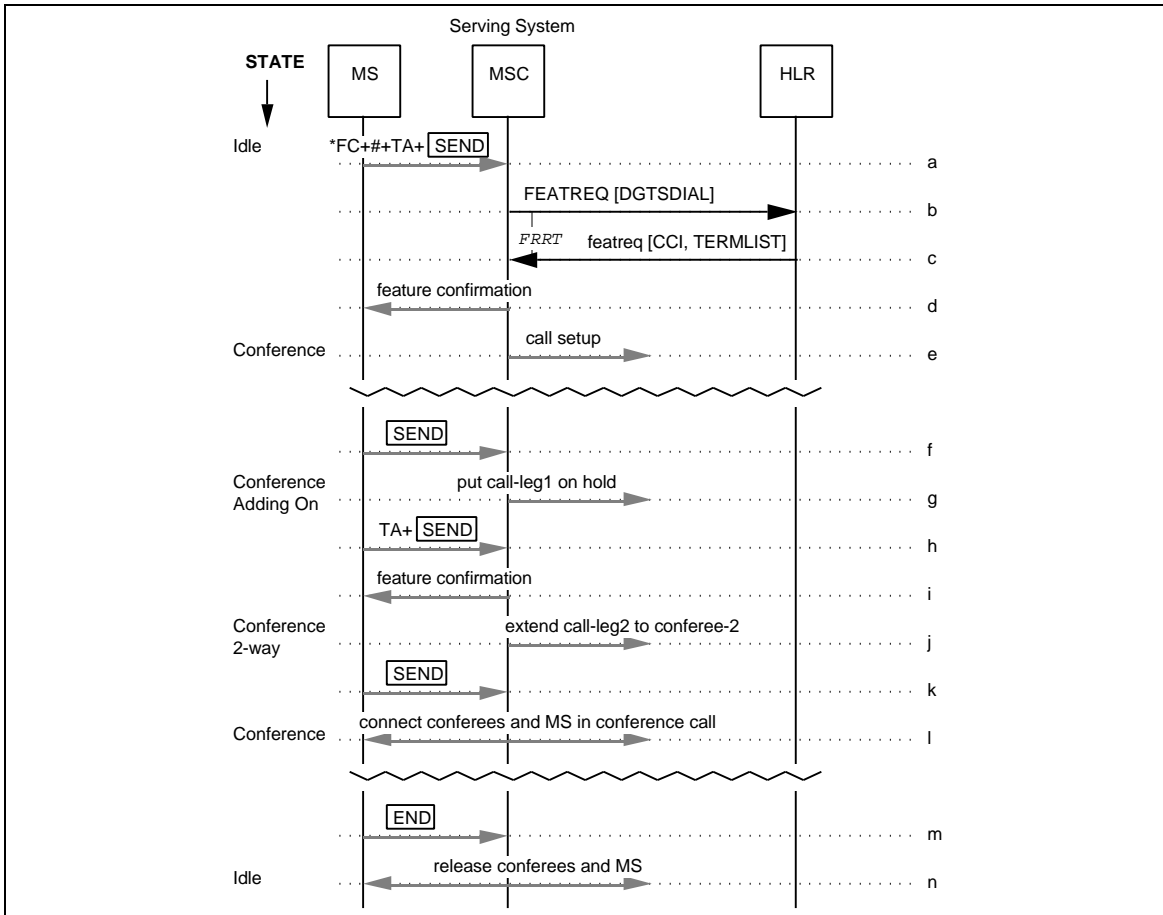

Figure 146 CC Add Party (Without Feature Code Entry)

1
2
3
4
5
6
7
8
9
10
11
12
13
14
15
16
17
18
19
20
21
22
23
24
25
26
27
28
29
30
31
32
33
34
35
36
37
38
39
40
41
42
43
44
45
46
47
48
49
50
51
52
53
54
55
56
57
58
59
60

- a-g. Same as CC, Section 6.10.1, Steps a-g.
- h. Dialed digits are received by the Serving MSC.
- i. Since a feature code string is not present, the Serving MSC provides treatment to the served MS based on the fact that conference calling is active. If the maximum number of conferees has not been exceeded, the Serving MSC applies call confirmation.
- j. The Serving MSC extends the call using the termination address digits provided (call-leg-2).
- k. MS-1 sends a flash request to the Serving MSC (i.e., presses the Ψ x(SEND) key).
- l. The Serving MSC connects the served MS, the held conferee and the new party into a conference call.
- m. MS-1 sends a Disconnect Request to the Serving MSC (i.e., presses the Ψ x(END) key).
- n. The Serving MSC releases the served MS and conferees and discards the ConferenceCallingIndicator information.

6.10.3 CC Invocation During a Call

This scenario describes the invocation of CC by an authorized MS. The invocation occurs during a call.

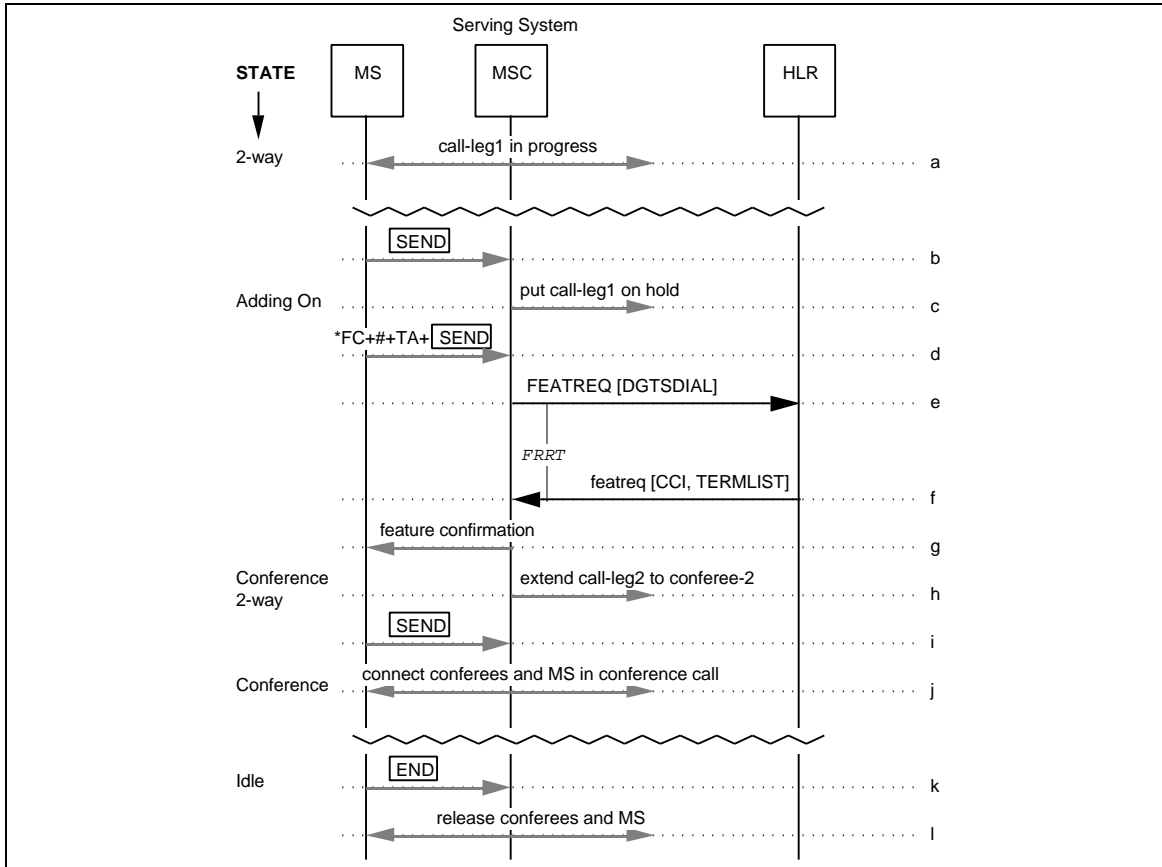

Figure 147 CC Invocation During a Call

- 1
2
3
4
5
6
7
8
9
10
11
12
13
14
15
16
17
18
- a. MS-1 is engaged in a call (call-leg-1)
 - b. MS-1 sends a flash request to the Serving MSC (i.e., presses the Ψ x(SEND) key).
 - c. The Serving MSC puts call-leg-1 on hold.
 - d. Dialed digits are received by the Serving MSC. During analysis of the dialed digits, the Serving MSC detects a feature code string.
 - e. The dialed digits are included in a FEATREQ and sent from the Serving MSC to the HLR associated with the MS.
 - f. The HLR detects the authorized CC request and sends a **featreq** to the Serving MSC. The **featreq** includes call routing information in the TerminationList parameter. It also includes the ConferenceCallingIndicator parameter, indicating that Conference Calling is active for the call.

19
20
21
22
23
24
25

Additional Parameters	Usage	Type
CCI	ConferenceCallingIndicator. Presence of this parameter indicates that the outgoing call is to be handled as a Conference Call. The parameter carries the maximum number of allowed conferees.	R

- 26
27
28
29
30
31
32
33
34
35
36
37
38
39
40
41
42
43
44
45
46
47
48
49
50
51
52
53
54
55
56
57
58
59
60
- g. The Serving MSC stores the ConferenceCallingIndicator information, activates conference calling, and provides treatment to the served MS as indicated in the **featreq**. In this case, the treatment is to apply feature confirmation.
 - h. The Serving MSC extends the call using the call routing information in the TerminationList parameter (call-leg-2).
 - i. MS-1 sends a flash request to the Serving MSC (i.e., presses the Ψ x(SEND) key).
 - j. The Serving MSC connects the served MS, the held conferee and the new party into a conference call.
 - k. MS-1 sends a Disconnect Request to the Serving MSC (i.e., presses the Ψ x(END) key).
 - l. The Serving MSC releases the served MS and conferees and discards the ConferenceCallingIndicator information.

6.10.4 CC Drop Last Party Invocation

This scenario describes the invocation of the CC Drop Last Party feature by an authorized MS. The invocation occurs during a call for which CC has been invoked.

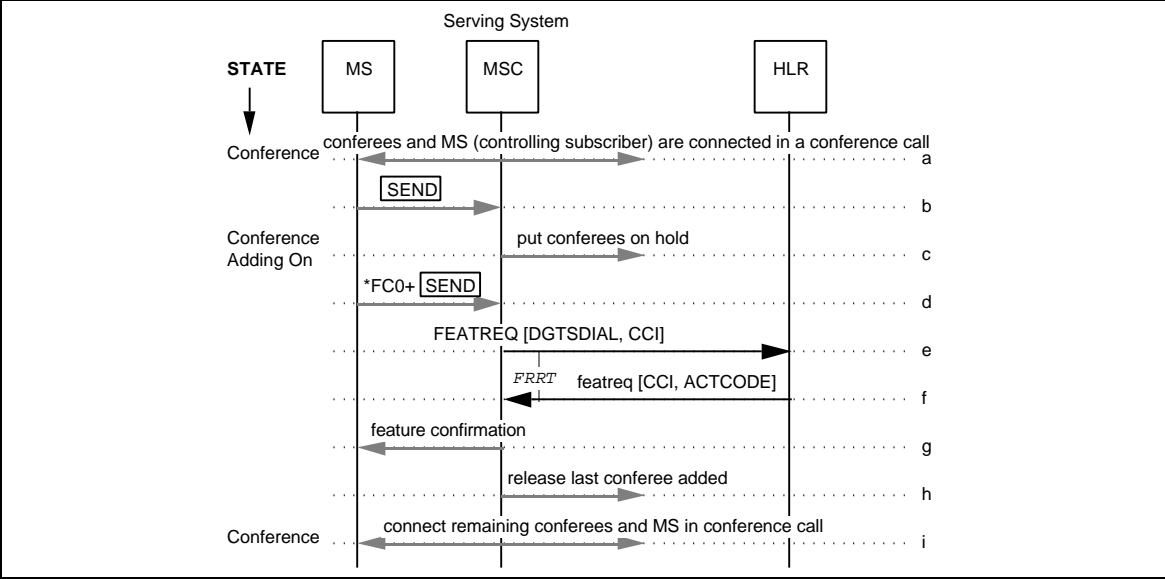

Figure 148 CC Drop Last Party Invocation

1
2
3
4
5
6
7
8
9
10
11
12
13
14
15
16
17
18
19
20
21
22
23
24
25
26
27
28
29
30
31
32
33
34
35
36
37
38
39
40
41
42
43
44
45
46
47
48
49
50
51
52
53
54
55
56
57
58
59
60

- a. A multi-party conference call is in progress, with MS-1 as the controlling subscriber.
- b. MS-1 sends a flash request to the Serving MSC (i.e., presses the ¥x (SEND) key).
- c. MSC-1 puts the conferees on hold, allowing them to converse. A warning tone may be applied to the conferees.
- d. MS-1 sends the CC drop last party feature code to the Serving MSC.
- e. The dialed digits are included in a **FEATREQ** and sent from the Serving MSC to the HLR. The Serving MSC also includes the **ConferenceCallingIndicator** parameter, indicating that the request is for a conference call already in progress.
- f. The HLR detects the authorized **CC DropLastParty** request and sends a **featreq** to the Serving MSC. The **featreq** includes an **ACTCODE** parameter set to *Conference Calling Drop Last Party*. It also includes the **ConferenceCallingIndicator** parameter indicating that Conference Calling is active for the call and the maximum number of allowed conferees.
- g. The Serving MSC provides treatment to the served MS as indicated in the **ACTCODE** parameter. In this case, the treatment is to apply feature confirmation.
- h. The Serving MSC releases the last party added to the conference call.
- i. The Serving MSC connects MS-1 and the remaining held conferees into a conference call.

6.11 Do Not Disturb

This section depicts the interactions between network entities in various situations related to automatic roaming and Do Not Disturb (DND). These scenarios are for illustrative purposes only.

6.11.1 DND Activation or De-Activation

The information flows required for the activation or de-activation of DND by an authorized MS are described in Section 5.5.1.

6.11.2 DND Invocation

This scenario describes the invocation of DND for an authorized MS.

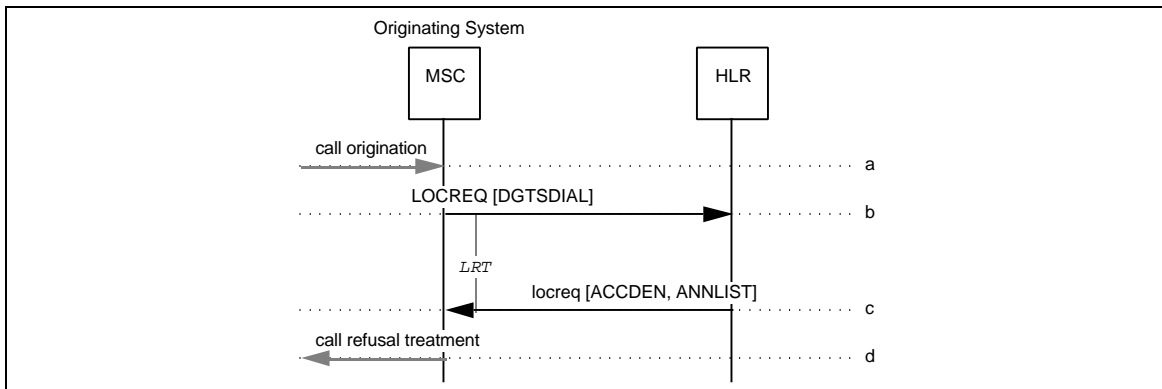

Figure 149 DND Invocation

- a. A call origination and the dialed MS address digits (i.e., directory number) are received by the Originating MSC.
- b. The Originating MSC sends a LOCREQ to the MS's HLR.
- c. The HLR determines from the MS's service profile that Do Not Disturb is active. The status of the MS is returned to the Originating MSC by the HLR via the AccessDeniedReason parameter in the lcreq. An AnnouncementList parameter may be included to specify the tones or announcements to be provided to the calling party.
- d. The Originating MSC provides treatment to the served MS as indicated in the lcreq. In this case, the treatment is to provide call refusal treatment.

6.11.3 DND Interaction with CFD or CFNA

The interaction of DND with CFD is described in Section 6.3.6, CFD Invocation--Immediate.

The interaction of DND with CFNA is described in Section 6.4.4, CFNA Invocation--Immediate.

6.11.4 DND Interaction with CFU

This scenario describes the interaction of DND with CFU for an authorized MS.

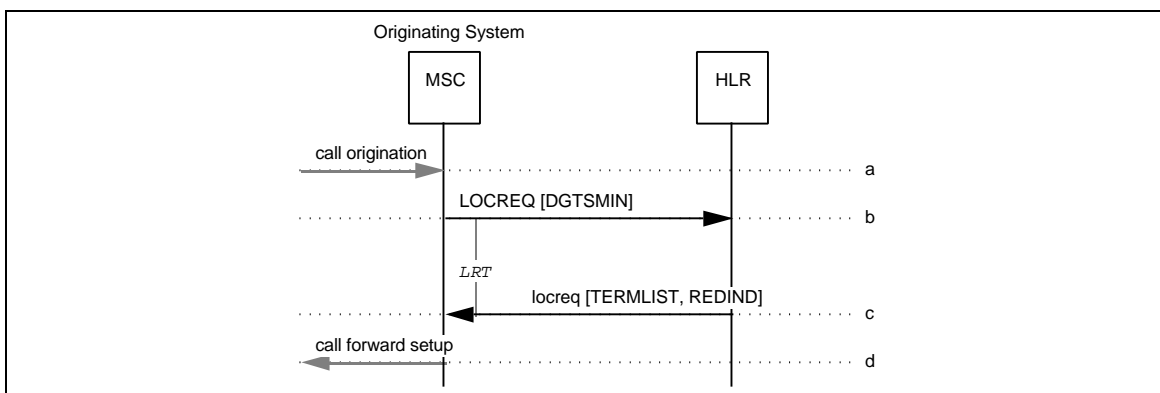

Figure 150 DND Interaction with CFU

- A call origination and the dialed MS address digits (i.e., directory number) are received by the Originating MSC.
- The Originating MSC sends a `LOCREQ` to the MS's HLR.
- The HLR determines from the MS's service profile that DND and CFU are active. Therefore, it sends a `locreq` to the Originating MSC providing the forward-to number and other routing information in the `TerminationList` parameter, along with an indication of the reason for extending the incoming call (i.e., for CFU) in the `DMH_RedirectionIndicator` parameter.
- The Originating MSC then establishes a call to the specified forward-to number.

Note that, since DND is active, the MS is not informed that a call has been forwarded unconditionally.

6.12 Flexible Alerting

This section depicts the interactions between network entities in various situations related to automatic roaming and Flexible Alerting (FA). These scenarios are for illustrative purposes only.

6.12.1 FA Membership Activation or De-Activation

The information flows required for the activation or de-activation of membership in the member's default or specified FA group by an authorized MS are described in Section 5.5.1.

6.12.2 FA Invocation

This scenario describes an invocation of FA. The FA group is comprised of three members: one member is a PSTN DN, FA-DN1; the other two members are MINs, MIN1 and MIN2, served by the same HLR and currently served by the same MSC.

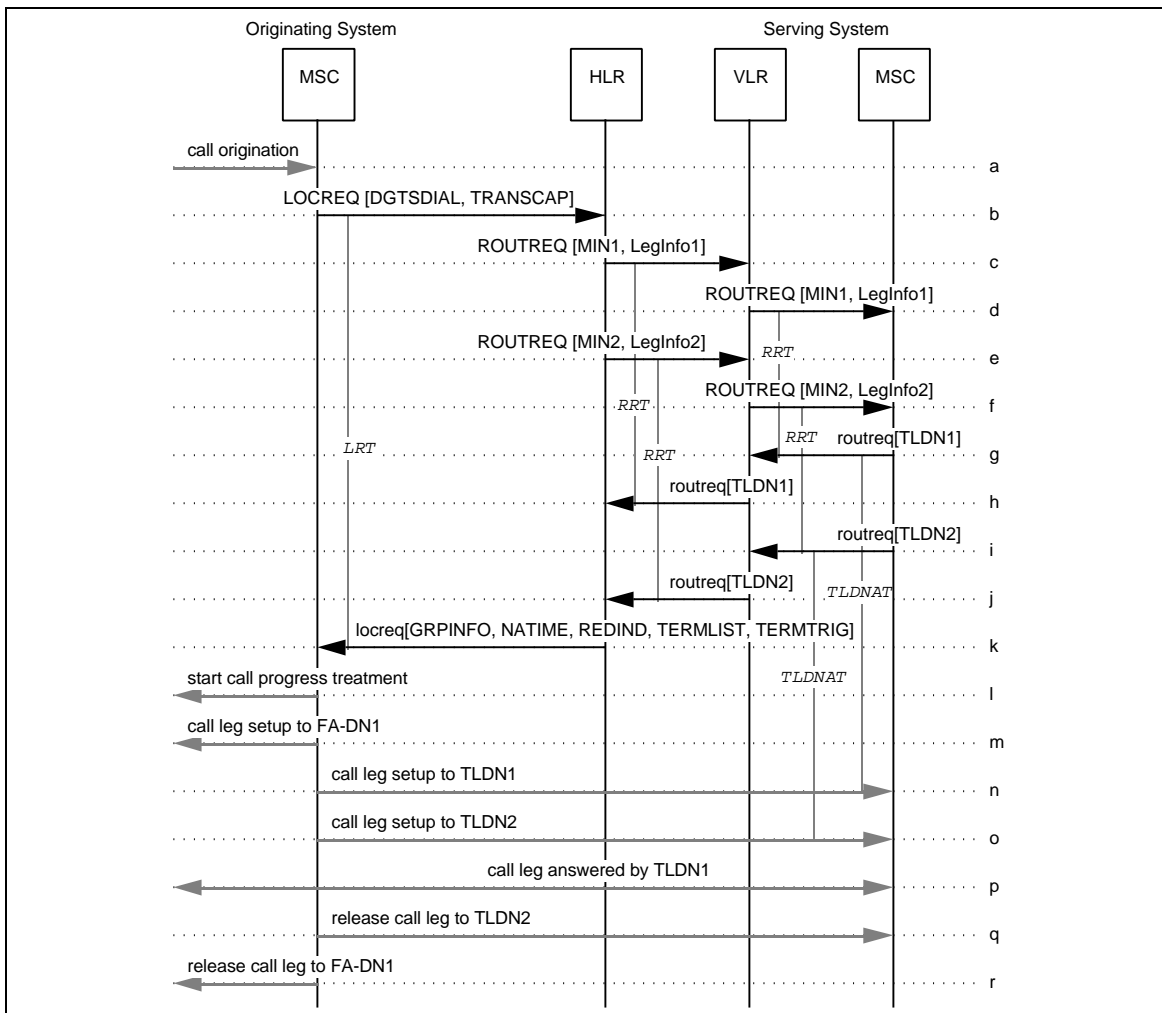

1
2
3
4
5
6
7
8
9
10
11
12
13
14
15
16
17
18
19
20
21
22
23
24
25
26
27
28
29
30
31
32
33
34
35
36
37
38
39
40
41
42
43
44
45
46
47
48
49
50
51
52
53
54
55
56
57
58
59
60

Figure 151 FA Invocation

- 1
2
3
4
5
6
7
8
9
10
11
12
13
14
15
16
- a. A call origination and the dialed MS address digits (i.e., directory number) are received by the Originating MSC.
 - b. The Originating MSC sends a **LOCREQ** to the HLR associated with the MS; this association is made through the dialed MS address digits (which may not be the MIN). The Originating MSC may optionally include the **TransactionCapability** parameter to specify the appropriate termination handling.
 - c-f. The HLR recognizes the called number as an FA Pilot DN and that, based on the received **TransactionCapability** parameter, the Originating MSC is capable of supporting an FA call. In this case, the two MINs in the FA group are registered in the same system; therefore, two **ROUTREQs** are sent to the Serving VLR and the VLR forwards the **ROUTREQs** to the Serving MSC.

17
18
19
20
21
22
23
24
25
26
27
28
29
30
31
32
33
34
35
36
37
38

Additional Parameters	Usage	Type
LegInfo1:	FA parameters for call leg to MIN1:	
[AlertCode]	Include for distinctive alerting of MIN1.	O
[LegInformation]	Used for HLR identification of call leg to MIN1. Include at HLR option.	O
[OneTimeFeature-Indicator]	Modify feature processing for the duration of this call leg.	O
[TerminationTriggers]	Include if termination trigger points are active for call leg to MIN1.	O
LegInfo2:	FA parameters for call leg to MIN2:	
[AlertCode]	Include for distinctive alerting of MIN2.	O
[LegInformation]	Used for HLR identification of call leg to MIN2. Include at HLR option.	O
[OneTimeFeature-Indicator]	Modify feature processing for the duration of this call leg.	O
[TerminationTriggers]	Include if termination trigger points are active for call leg to MIN2.	O

- 39
40
41
42
43
44
45
46
47
48
49
50
51
52
53
54
55
56
57
58
59
60
- g-j. In reaction to each **ROUTREQ**, the Serving MSC checks its internal data structures and determines that the MS is currently idle, then allocates a **TLDN** and returns this information to the VLR in a **routeq**. The VLR sends each **routeq** to the HLR.

- 1
2
3
4
5
6
7
8
- k. When all **roureqs** are received by the HLR, it returns a **locreq** to the Originating MSC. The **locreq** includes multiple-termination routing information in the form of the **TerminationList** parameter, along with an indication of the reason for extending the incoming call (i.e., for FA) in the **DMH_RedirectionIndicator** parameter.

9
10
11
12
13
14
15
16
17
18
19
20

Additional Parameters	Usage	Type
TERMLIST	List of FA group members' identification information, from first member to last.	R
GRPINFO	Information associated with the FA Pilot DN.	O
NATIME	Indication of how long, in seconds, the Originating MSC should wait before applying no answer treatment. Include to override Originating MSC default.	O
TERMTRIG	Indicates active termination trigger points for members not having TerminationTriggers inside the TerminationList .	O

- 21
22
23
24
25
26
27
28
29
30
31
32
33
34
35
36
37
38
39
40
41
42
43
44
45
46
47
48
49
50
51
52
53
54
55
56
57
58
59
60
- l. On receipt of the **locreq**, the Originating MSC may start call progress treatment to the calling party, if it has not already done so.
- m. The Originating MSC provides call treatment as indicated in the **locreq**. In this case, the treatment is to attempt to establish, in parallel, calls to the FA-DN1...
- n. ...to the TLDN1, and ...
- o. ...to the TLDN2. In general, these calls may require outgoing trunks or be internal to the Originating MSC. For each call attempt, the Originating MSC monitors call progress; based on this information, it applies appropriate call progress treatment to the calling party.
- p. The party at TLDN1 answers. The Originating MSC connects the calling party to the party at TLDN1.
- q. The Originating MSC releases the call to TLDN2, and...
- r. The Originating MSC releases the call to FA-DN1.

6.12.3 FA Invocation with a Busy FA Group Member (Single-User Type)

This scenario describes an invocation of FA where a member busy condition is encountered. The FA group is comprised as described in Section 6.12.2. The FA group is the single-user type (i.e., the FA group is considered busy when a member of the FA group is busy).

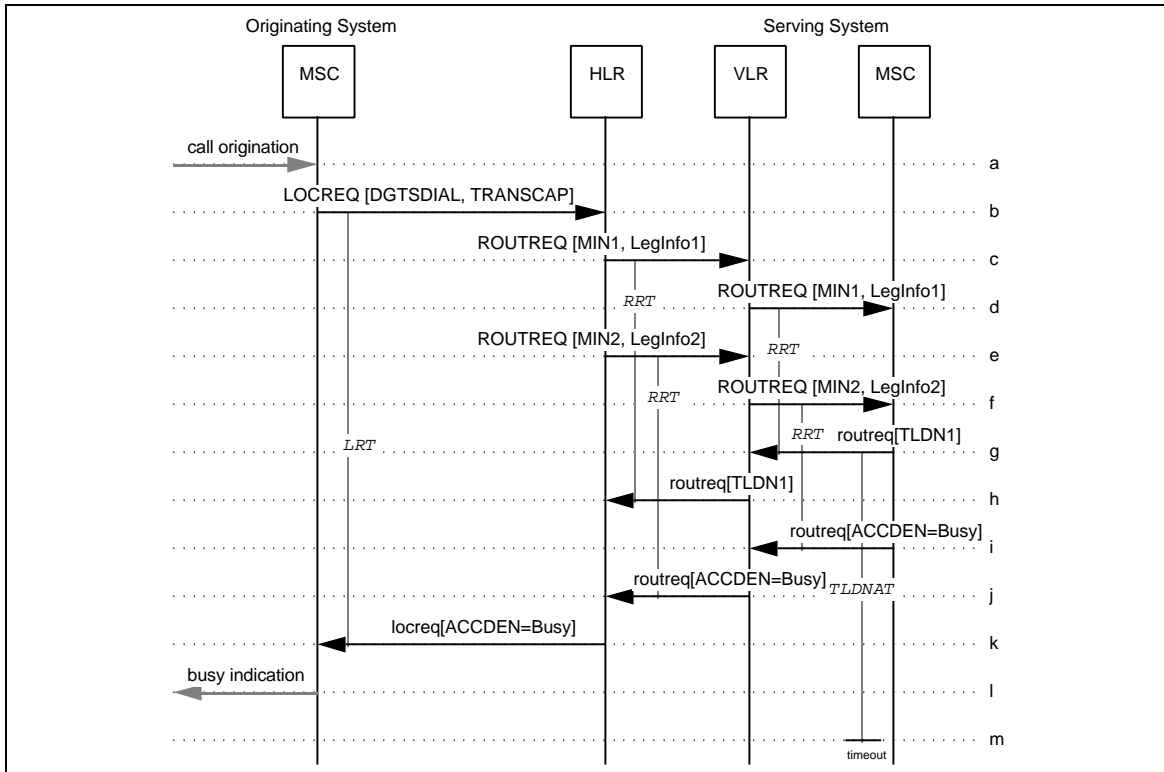

Figure 152 FA Invocation with a Busy FA Group Member (Single-User Type)

1
2
3
4
5
6
7
8
9
10
11
12
13
14
15
16
17
18
19
20
21
22
23
24
25
26
27
28
29
30
31
32
33
34
35
36
37
38
39
40
41
42
43
44
45
46
47
48
49
50
51
52
53
54
55
56
57
58
59
60

- a-f. Same as FA, Section 6.12.2, Steps a-f.
- g-h. In reaction to the **ROUTREQ** received in Step-d, the Serving MSC checks its internal data structures and determines that the MS is currently idle, then allocates a TLDN and returns this information to the VLR in a **roureq**. The VLR sends the **roureq** to the HLR.
- i-j. In reaction to the **ROUTREQ** received in Step-f, the Serving MSC checks its internal data structures and determines that the MS is currently busy in another call. The status of the MS is returned to the VLR by the Serving MSC in the **roureq**. The VLR sends the **roureq** to the HLR.
- k. The HLR determines from the service profile that the FA group is a single-user type; therefore, the group is considered busy (i.e., since MIN2 is busy). The HLR returns the busy status to the Originating MSC in the **locreq**.
- l. The Originating MSC then returns a busy indication to the calling party.
- m. The Serving MSC detects that the TLDN Association Timer (TLDNAT) set for a MS expires; therefore, it frees the TLDN for other use and removes the record associated with that TLDN.

6.12.4 FA Invocation with a Busy FA Group Member (Multiple-User Type)

This scenario describes an invocation of FA where a member busy condition is encountered. The FA group is comprised as described in Section 6.12.2. The FA group is the multiple-user type (i.e., the FA group is considered busy when all members of the FA group are busy).

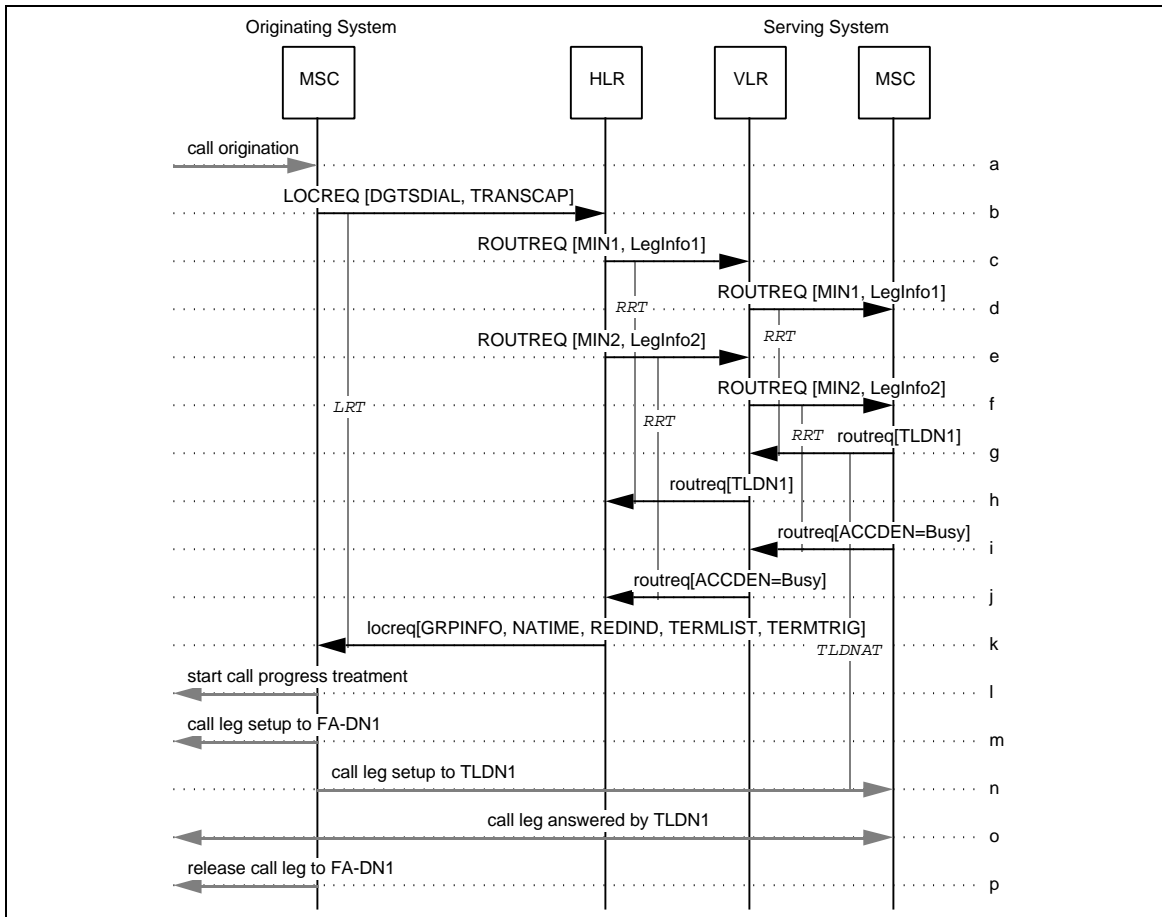

Figure 153 FA Invocation with a Busy FA Group Member (Multiple-User Type)

a-f. Same as FA, Section 6.12.2, Steps a-f.

g-j. Same as FA, Section 6.12.3, Steps g-j.

k. The HLR determines from the service profile that the FA group is a multiple-user type; therefore, the group is not considered busy even though MIN2 is busy. The HLR returns a `locreq` to the Originating MSC. The `locreq` includes multiple-termination routing information in the form of the `TerminationList` parameter, along with an indication of the reason for extending the incoming call (i.e., for FA) in the `DMH_RedirectionIndicator` parameter.

Additional Parameters	Usage	Type
TERMLIST	List of FA group members' identification information, from first member to last, excluding the busy member.	R
GRPINFO	Information associated with the FA Pilot DN.	O
NATIME	Indication of how long, in seconds, the Originating MSC should wait before applying no answer treatment. Include to override Originating MSC default.	O
TERMTRIG	Indicates active termination trigger points for members not having <code>TerminationTriggers</code> inside the <code>TerminationList</code> .	O

l. On receipt of the `locreq`, the Originating MSC may start call progress treatment to the calling party, if it has not already done so.

m. The Originating MSC provides call treatment as indicated in the `locreq`. In this case, the treatment is to attempt to establish, in parallel, calls to FA-DN1, and ...

n. ...TLDN1. In general, these calls may require outgoing trunks or be internal to the Originating MSC. For each call attempt, the Originating MSC monitors call progress; based on this information, it applies appropriate call progress treatment to the calling party.

o. The party at TLDN1 answers. The Originating MSC connects the calling party to the party at TLDN1, and ...

p. The Originating MSC releases the call to FA-DN1.

6.12.5 FA Invocation with a No Answer FA Group Member with Member Redirection

This scenario describes an invocation of FA where a member no answer condition is encountered and forwarding is done on the member. The FA group is comprised as described in Section 6.12.2.

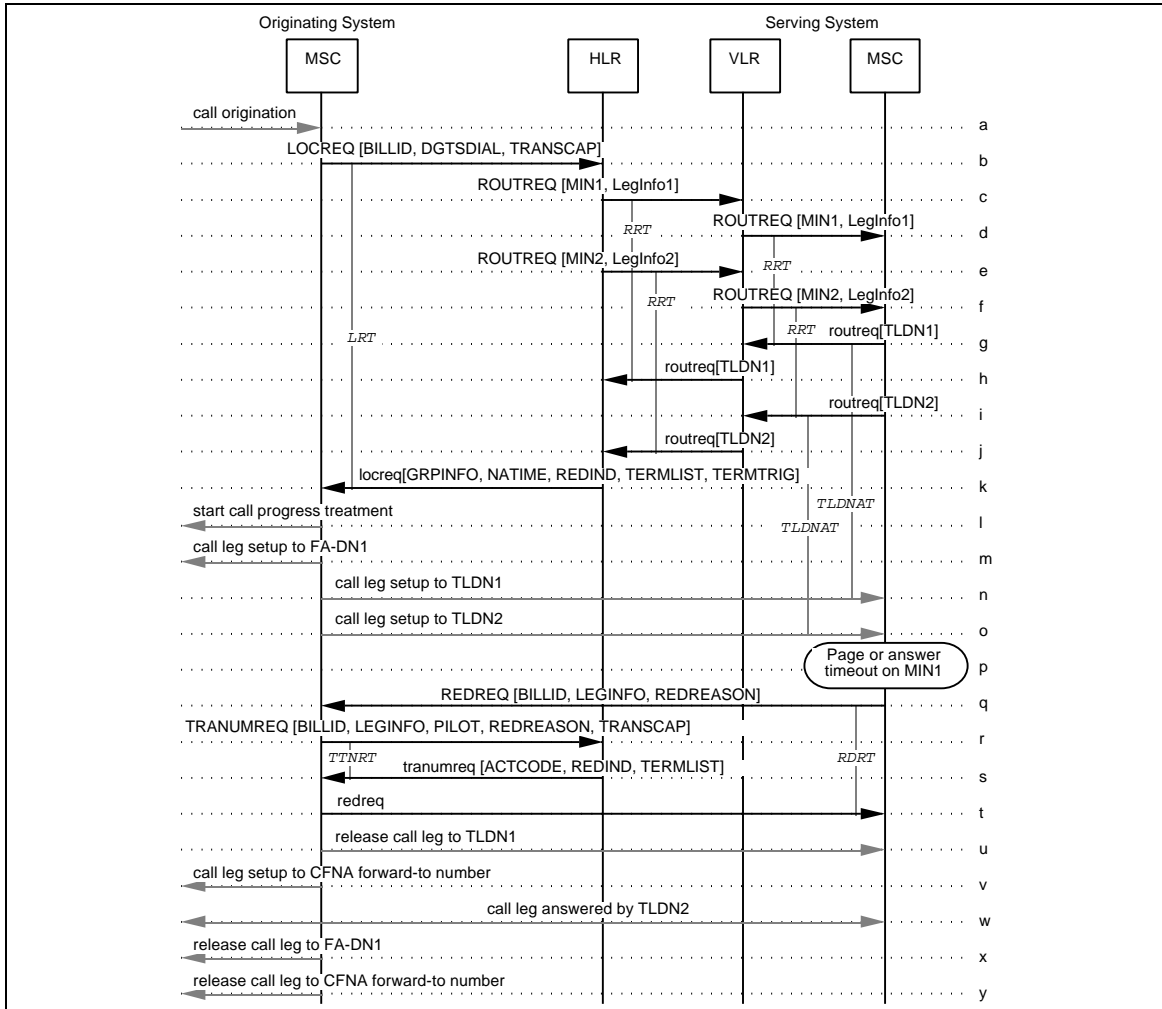

Figure 154 FA Interaction with CFNA on FA Group Member

- 1
2
3
4
5
6
7
8
9
10
11
12
13
14
- a-o. Same as FA, Section 6.12.2, Steps a-o.
- p. When the call for MIN1 is received at the Serving MSC, the MS is paged and, if a page response is received, subsequently alerted. The MS fails to respond to the page or does not answer after alerting; the Serving MSC determines from the service profile (including the profile overrides based on the TerminationTriggers parameter) that MIN1 has call forwarding active on no answer or no response to page conditions.
- q. The Serving MSC sends a REDREQ to the Originating MSC and includes the originating BillingID and RedirectionReason parameters to indicate that the call is being redirected due to a *no answer* or *no page response* condition.

Additional Parameters	Usage	Type
LEGINFO	LegInformation. Used for HLR identification of call leg to MIN1. Include if available.	R

- 15
16
17
18
19
20
21
22
- r. If the Originating MSC is able to redirect the call, it sends a TRANUMREQ to the HLR requesting the forward-to number appropriate for the *no answer* or *no page response* condition from the MS's service profile. Refer to Section 6.2.5 for procedures if the Originating MSC is not able to redirect the call.

Additional Parameters	Usage	Type
BILLID	BillingID. Used by HLR to relate the transfer request to the original FA call invocation.	R
PILOT	PilotNumber. May be used by HLR to relate the transfer request to the original FA call invocation.	R
REDREASON	Indicates the reason for requesting a transfer-to number	R
LEGINFO	LegInformation. Used for HLR identification of call leg to MIN1. Include if available.	O
TRANSCAP	Indicates whether or not the Originating MSC is capable of supporting an FA call.	O

- 23
24
25
26
27
28
29
30
31
32
33
34
35
36
37
38
39
40
41
42
- s. The HLR may use the BillingID or the PilotNumber and LegInformation to relate the transfer request to the original FA call. It may then check the service profile of the FA Pilot DN for CFNA. If precedence is given to the FA Pilot DN's CFNA and if it is active, the forward-to number is that of the FA Pilot DN.

43
44
45
46
47
48

The HLR sends a `tranumreq` to the Originating MSC, including the appropriate forward-to number, as well as the new value of the LegInformation, in the TerminationList parameter. Also included is an indication of the reason for extending the incoming call (i.e., for CFNA) in the DMH_RedirectionIndicator parameter. Optionally, an ActionCode set to *Disconnect call leg* may be included.

- 49
50
51
52
53
54
55
56
57
58
59
60
- t. When the `tranumreq` is received from the HLR, the Originating MSC sends a `redreq` to the Serving MSC.
- u. The Originating MSC releases the voice path to the Serving MSC.
- v. The Originating MSC initiates call forwarding using the specified forward-to number.
- w. The party at TLDN2 answers. The Originating MSC connects the calling party to the party at TLDN2.

1
2
3
4
5
6
7
8
9
10
11
12
13
14
15
16
17
18
19
20
21
22
23
24
25
26
27
28
29
30
31
32
33
34
35
36
37
38
39
40
41
42
43
44
45
46
47
48
49
50
51
52
53
54
55
56
57
58
59
60

- x. The Originating MSC releases the call to FA-DN1, and ...
- y. The Originating MSC releases the call to the forward-to number.

6.12.6 FA Invocation with a No Answer FA Group Member with Group Redirection

This scenario describes an invocation of FA where a member no answer condition is encountered and forwarding is done on the FA Pilot Group (i.e. The TerminationTriggers from outside the TerminationList are hit). The Pilot HLR is queried and returns a group forwarding number in the TerminationList. The FA group is comprised as described in Section 6.12.2.

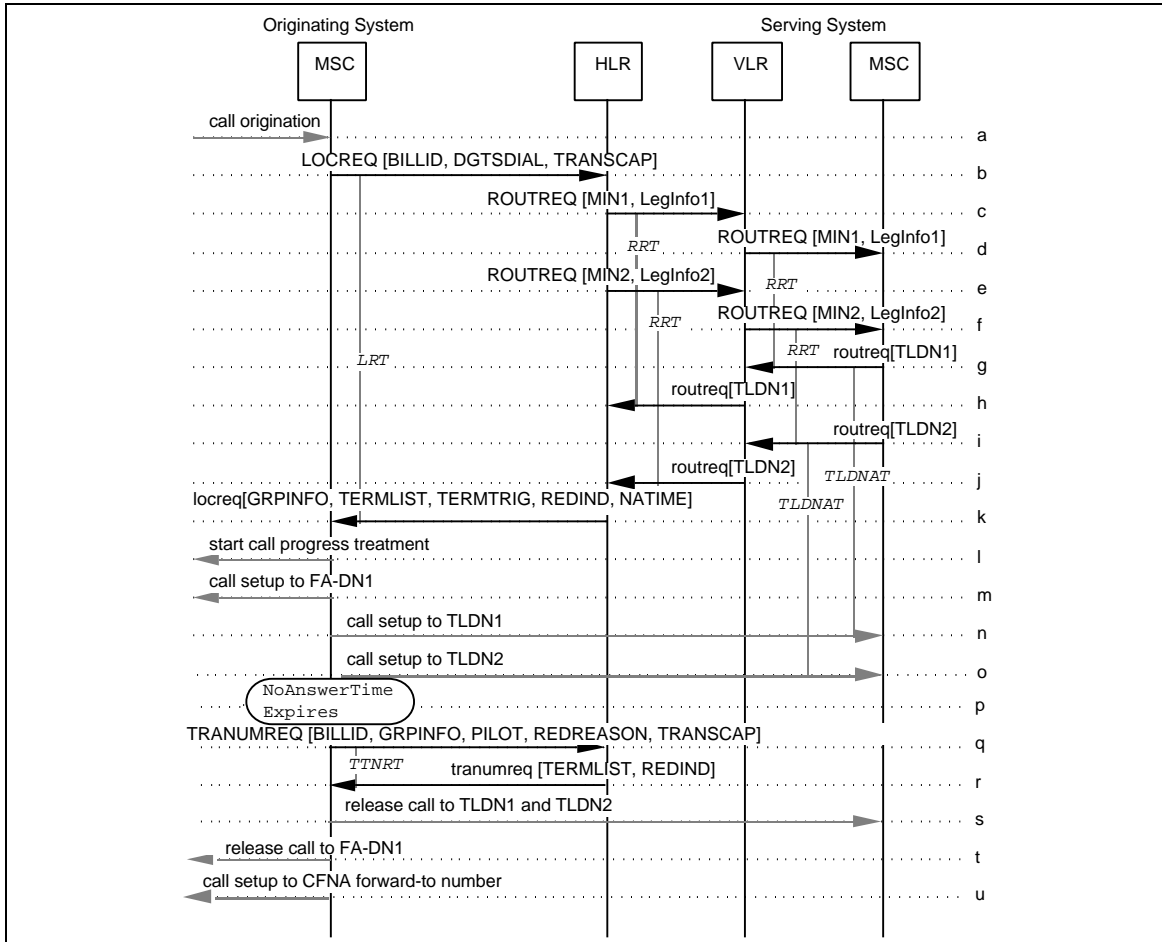

Figure 155 FA Invocation with a No Answer FA Group Member with Group Redirection

- a-o. Same as FA, Section 6.12.2, Steps a-o.
- p. The NoAnswerTime in the Originating MSC expires.
- q. If the Originating MSC is able to redirect the call, it sends a TRANUMREQ, containing the GroupInformation if available, to the HLR requesting the forward-to number appropriate for the *no answer* or *no page response* condition from the MS's service profile. Refer to Section 6.2.5 for procedures if the Originating MSC is not able to redirect the call.

1
2
3
4
5
6
7
8
9
10
11
12
13
14
15
16
17
18
19
20
21
22
23
24
25
26
27
28
29
30
31
32
33
34
35
36
37
38
39
40
41
42
43
44
45
46
47
48
49
50
51
52
53
54
55
56
57
58
59
60

Additional Parameters	Usage	Type
BILLID	BillingID. May be used by HLR to relate the transfer request to the original FA call invocation.	R
PILOT	PilotNumber. May be used by HLR to relate the transfer request to the original FA call invocation.	R

- r. The HLR may use the BillingID or the PilotNumber and GroupInformation to relate the transfer request to the original FA call. The HLR sends a `tranumreq` to the Originating MSC, including the appropriate forward-to number for the FA Group in the TerminationList parameter and an ActionCode set to *Drop all call legs*. Also included is an indication of the reason for extending the incoming call (i.e., for CFNA) in the DMH_RedirectionIndicator parameter.
- s. The Originating MSC releases the voice path to TLDN1 and TLDN2, and...
- t. The Originating MSC releases the call to FA-DN1, and ...
- u. The Originating MSC initiates call forwarding using the specified forward-to number.

6.12.7 FA Invocation on Revertive Call to FA Pilot DN

This scenario describes the invocation of FA when the call is originated by a member of the FA group whose MIN is the FA Pilot DN. The FA group is comprised as described in Section 6.12.2 (where one of the MINs in the group is the FA Pilot DN). The FA group is the multiple-user type (i.e., the FA group is considered busy when all accessible members of the FA group are busy). An ORREQ is used because the *Revertive Call* trigger in the *OriginationTriggers* parameter is set.

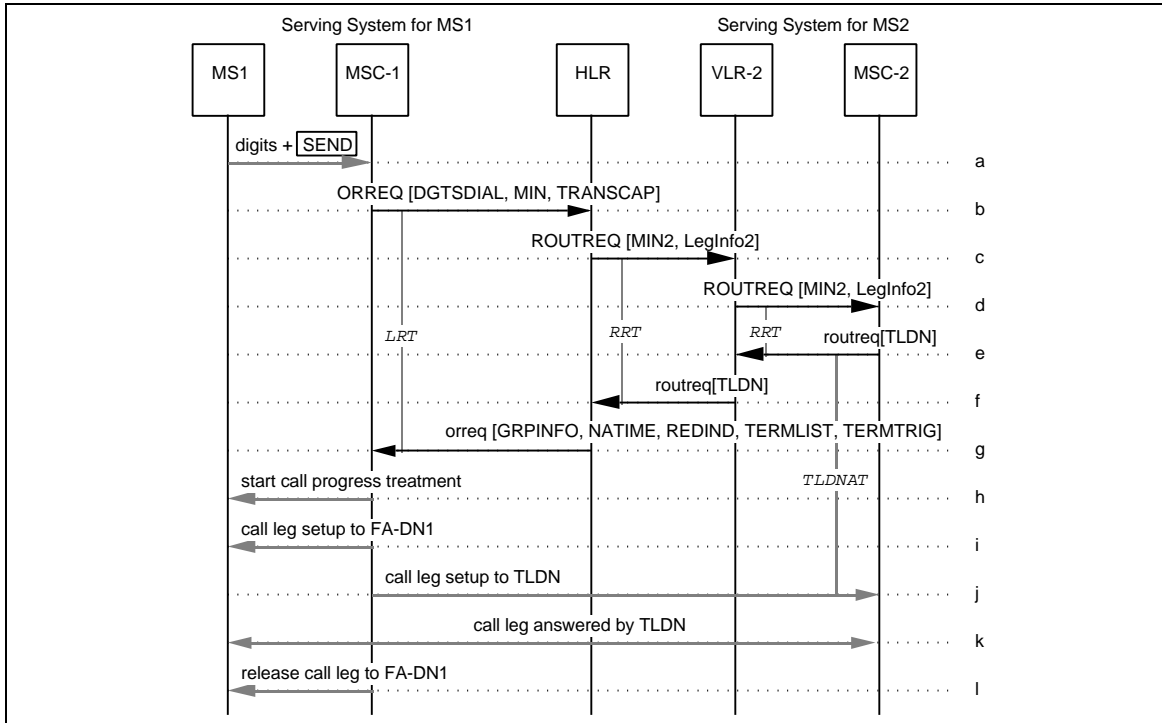

Figure 156 FA Invocation on Revertive Call to FA Pilot DN

- 1
2
3
4
5
6
7
8
9
10
11
12
13
14
15
- a. Dialed digits are received by the Serving MSC.
 - b. The Serving MSC detects that the dialed digits correspond to the served MS's MDN and the *Revertive Call* OriginationTriggers is set. The Digits Dialed and TransactionCapability are included in an ORREQ and sent from the Serving MSC to the HLR associated with the MS. The MS's MIN is also included.
 - c. The HLR recognizes the called number as an FA Pilot DN and the calling party as the FA Pilot DN (based on the MIN). It also recognizes that, based on the received TransactionCapability parameter, the Serving MSC is capable of supporting an FA call. Therefore, the HLR skips the FA Pilot DN and sends a ROUTREQ to the VLR where the other MIN in the FA group (i.e., MIN2) is registered.

16
17
18
19
20
21
22
23
24
25
26
27

Additional Parameters	Usage	Type
LegInfo2:	FA parameters for call leg to MIN2:	
[AlertCode]	Include for distinctive alerting of MIN2.	O
[LegInformation]	Used for HLR identification of call leg to MIN2. Include at HLR option.	O
[OneTimeFeature-Indicator]	Modify feature processing for the duration of this call leg.	O
[TerminationTriggers]	Include if termination trigger points are active for call leg to MIN2.	O

- 28
29
30
31
32
33
34
35
36
37
38
39
- d. The VLR sends the ROUTREQ to the Serving MSC.
 - e. In reaction to the ROUTREQ, the Serving MSC checks its internal data structures and determines that the MS is currently idle, then allocates a TLDN and returns this information to the VLR in a routreq.
 - f. The VLR sends the routreq to the HLR.
 - g. The HLR returns an orreq to the Serving MSC. The orreq includes multiple-termination routing information in the form of the TerminationList parameter, along with an indication of the reason for extending the incoming call (i.e., for FA) in the DMH_RedirectionIndicator parameter.

40
41
42
43
44
45
46
47
48
49
50
51
52
53

Additional Parameters	Usage	Type
TERMLIST	List of FA group members' identification information, from first member to last, excluding the FA Pilot DN.	R
GRPINFO	Information associated with the FA Pilot DN.	O
NATIME	Indication of how long, in seconds, the Originating MSC should wait before applying no answer treatment. Include to override Originating MSC default.	O
TERMTRIG	Indicates active termination trigger points for members not having TerminationTriggers inside the TerminationList.	O

- 54
55
56
57
58
59
60
- h. On receipt of the orreq, the Serving MSC may start call progress treatment to the calling party, if it has not already done so.

1
2
3
4
5
6
7
8
9
10
11
12
13
14
15
16
17
18
19
20
21
22
23
24
25
26
27
28
29
30
31
32
33
34
35
36
37
38
39
40
41
42
43
44
45
46
47
48
49
50
51
52
53
54
55
56
57
58
59
60

- i. The Serving MSC provides call treatment as indicated in the `orreq`. In this case, the treatment is to attempt to establish, in parallel, calls to FA-DN1, and ...
- j. ...TLDN. In general, these calls may require outgoing trunks or be internal to the Serving MSC. For each call attempt, the Serving MSC monitors call progress; based on this information, it applies appropriate call progress treatment to the calling party.
- k. The party at TLDN answers. The Serving MSC connects the calling party to the party at TLDN, and ...
- l. The Serving MSC releases the call to FA-DN1.

6.12.8 FA Invocation on Call from FA Group Member

This scenario describes the invocation of FA when the call is originated by a member of the FA group. The other (two) termination addresses in the FA group are directory numbers (DNs). The FA group is the multiple-user type (i.e., the FA group is considered busy when all accessible members of the FA group are busy).

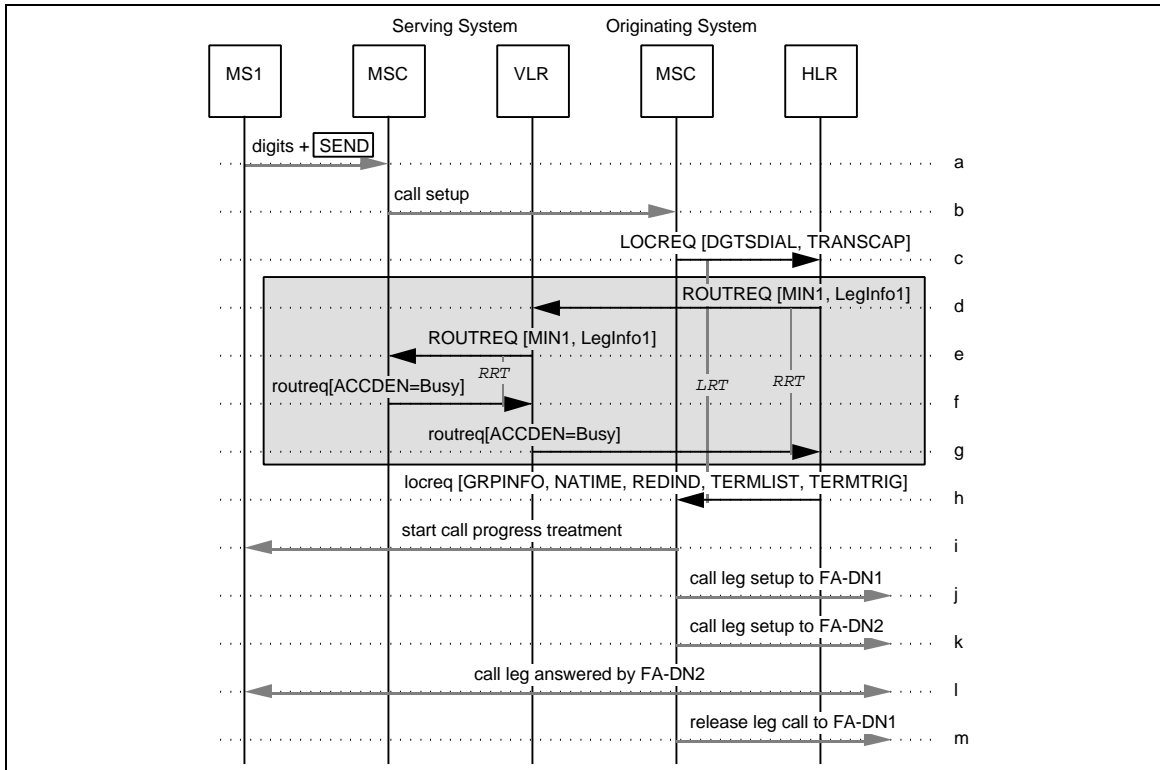

Figure 157 FA Invocation on Call from FA Group Member

- Dialed digits are received by the Serving MSC.
- The Serving MSC establishes a call to the Originating MSC.
- The dialed digits and the TransactionCapability parameter are included in a LOCREQ and sent from the Originating MSC to the HLR associated with the MS.
- The HLR recognizes the called number as an FA Pilot DN. It also recognizes that, based on the received TransactionCapability parameter, the Originating MSC is capable of supporting an FA call.

The FA group contains three numbers: FA-DN1, FA-DN2, and the MIN of MS1, MIN1. If the HLR is aware that the calling party is MS1 (e.g., via calling party number information in the call setup), it may skip to Step-h. Otherwise, the HLR constructs a ROUTREQ and sends it to the VLR where MS1 is registered.

Additional Parameters	Usage	Type
LegInfo1:	FA parameters for call leg to MIN1:	
[AlertCode]	Include for distinctive alerting of MIN1.	O
[LegInformation]	Used for HLR identification of call leg to MIN2. Include at HLR option.	O
[OneTimeFeature-Indicator]	Modify feature processing for the duration of this call leg.	O
[TerminationTriggers]	Include if termination trigger points are active for call leg to MIN1.	O

- e. The VLR forwards the **ROUTREQ** to the current Serving MSC.
- f. In reaction to the **ROUTREQ**, the Serving MSC checks its internal data structures and determines that the MS is busy in another call. The status of the MS is returned to the VLR by the Serving MSC in the **roureq**.
- g. The VLR sends the **roureq** to the HLR.
- h. Since MS1 is busy and the FA group is the multiple-user type (i.e., the FA group is considered busy when all accessible members of the FA group are busy), the HLR skips MS1 and sends a **locreq** to the Originating MSC. The **locreq** includes multiple-termination routing information in the form of the **TerminationList** parameter, along with an indication of the reason for extending the incoming call (i.e., for FA) in the **DMH_RedirectionIndicator** parameter.

Additional Parameters	Usage	Type
TERMLIST	List of FA group members' identification information, from first member to last, excluding the busy member.	R
GRPINFO	Information associated with the FA Pilot DN.	O
NATIME	Indication of how long, in seconds, the Originating MSC should wait before applying no answer treatment. Include to override Originating MSC default.	O
TERMTRIG	Indicates active termination trigger points for members not having TerminationTriggers inside the TerminationList .	O

- i. On receipt of the **locreq**, the Originating MSC may start call progress treatment to the calling party, if it has not already done so.
- j. The Originating MSC provides call treatment as indicated in the **locreq**. In this case, the treatment is to attempt to establish, in parallel, calls to FA-DN1, and ...
- k. ...FA-DN2. In general, these calls may require outgoing trunks or be internal to the Originating MSC. For each call attempt, the Originating MSC monitors call progress; based on this information, it applies appropriate call progress treatment to the calling party.
- l. The party at FA-DN2 answers. The Originating MSC connects the calling party to the party at FA-DN2, and ...
- m. The Originating MSC releases the call to FA-DN1.

6.13 Message Waiting Notification

This section depicts the interactions between network entities in various situations related to automatic roaming and Message Waiting Notification (MWN). These scenarios are for illustrative purposes only.¹

6.13.1 MWN Alert Pip Tone Activation or De-Activation

The information flows required for the activation or de-activation of MWN Alert Pip Tone by an authorized MS are described in Section 5.5.1.

6.13.2 Temporary De-Activation of MWN PIP Tone (with call setup)

This scenario describes the temporary de-activation of MWN PIP Tone by an authorized MS. The de-activation occurs coincident with the call origination.

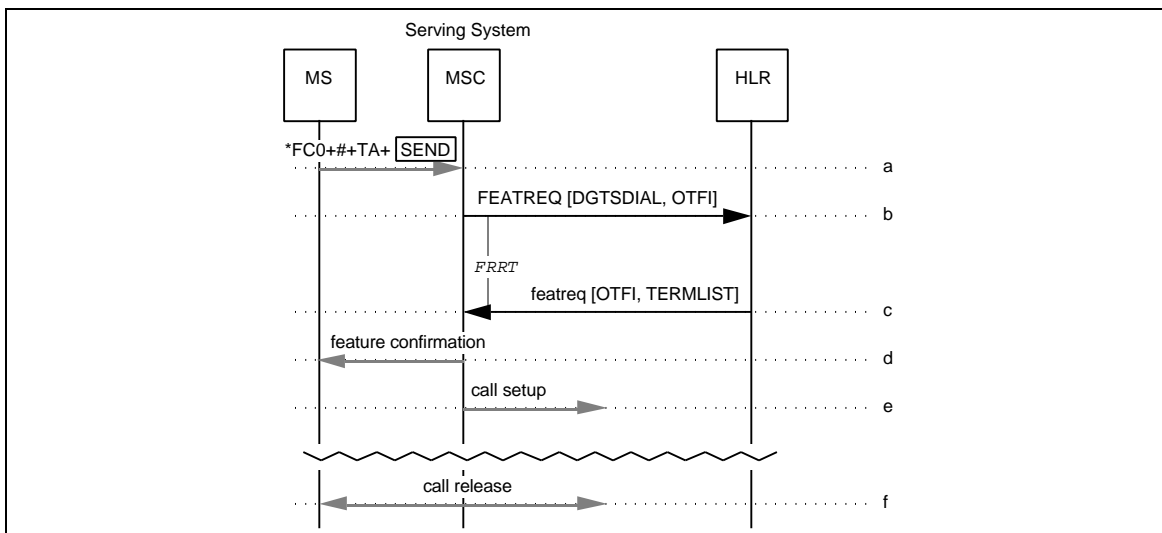

Figure 158 Temporary De-Activation of MWN PIP Tone (with call setup)

¹Refer to *IS-53-A* for an explanation of MWN subscription options.

- 1
2
3
4
5
6
7
8
9
10
- a. A call origination and dialed digits are received by the Serving MSC. During analysis of the dialed digits, the Serving MSC detects a feature code string.
 - b. The dialed digits are included in a **FEATREQ** and sent from the Serving MSC to the HLR associated with the MS. The Serving MSC also includes the **OneTimeFeatureIndicator** parameter if any of its status bits are set (i.e., if any special feature processing is active for the call).

Additional Parameters	Usage	Type
OTFI (Current Call)	Indicates special feature processing active for duration of call in progress.	O

- 11
12
13
14
15
16
17
18
19
- c. The HLR detects the authorized MWN Pip Tone de-activation request and sends a **featreq** to the Serving MSC. The **featreq** includes call routing information in the **TerminationList** parameter. It also includes the **OneTimeFeatureIndicator** parameter, with an indication that MWN Pip Tone is de-activated for the call.

Additional Parameters	Usage	Type
OTFI (Current Call)	Modify feature processing for duration of call in progress = De-activate MWN Pip Tone.	R

- 20
21
22
23
24
25
26
27
28
29
30
31
32
33
34
35
36
37
38
39
40
41
42
43
44
45
46
47
48
49
50
51
52
53
54
55
56
57
58
59
60
- d. The Serving MSC stores the **OneTimeFeatureIndicator**, de-activates MWN Pip Tone, and provides treatment to the served MS as indicated in the **featreq**. In this case, the treatment is to apply feature confirmation.
 - e. The Serving MSC extends the call using the call routing information in the **TerminationList** parameter.
 - f. The **OneTimeFeatureIndicator** remains active until the end of the call, at which time it is discarded by the Serving MSC. The MWN Pip Tone activation status then returns to its pre-call condition.

6.13.3 MWN via Alert Pip Tones

This scenario describes message waiting notification via the alert pip tone option.

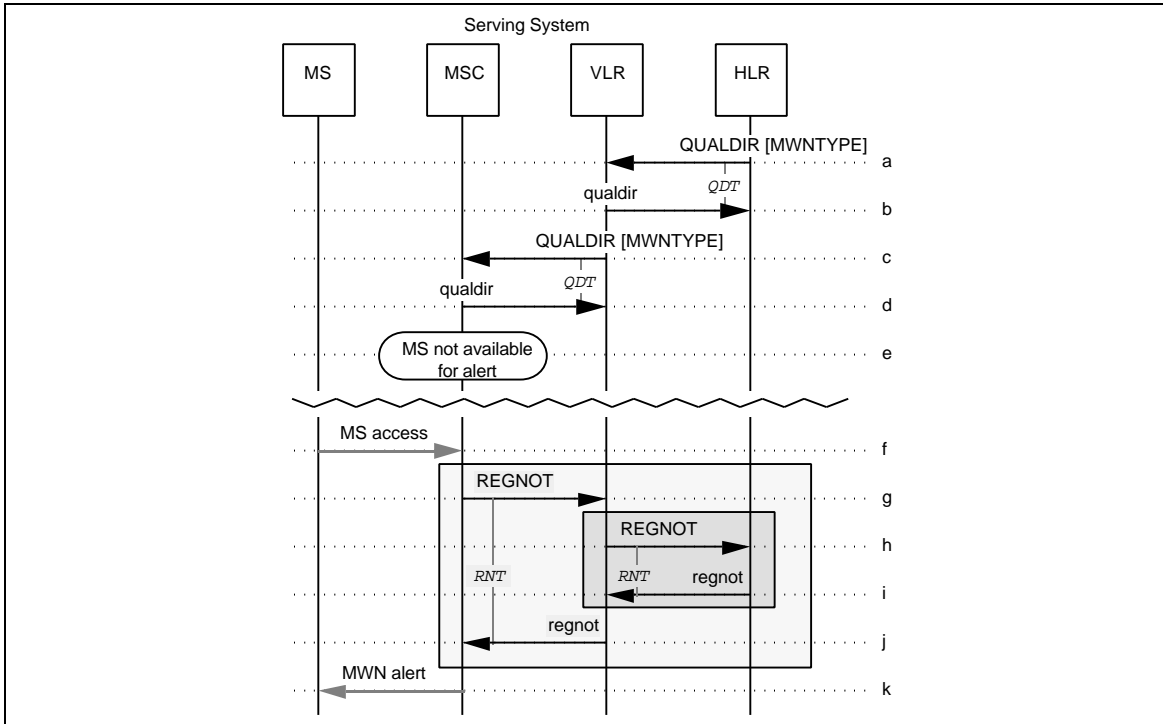

Figure 159 MWN via Alert Pip Tone

- 1
2
3
4
5
6
- a. An undelivered voice mail message is waiting to be delivered to the subscriber. The HLR reports the change in the MS's message waiting status by sending a **QUALDI R** to the VLR where the MS is registered.

Additional Parameters	Usage	Type
MWNTYPE	Indicates that MWN Alert Pip Tone notification is required.	R

- 7
8
9
10
11
12
13
14
15
16
17
18
19
20
21
22
23
24
25
26
- b. The VLR sends a **qual di r** to the HLR.
- c. The VLR reports the change in the MS's message waiting status by sending a **QUALDI R** to the Serving MSC. Additional parameters are as in Step -b.
- d. The Serving MSC sends a **qual di r** to the VLR.
- e. The MS is not available for alerting, therefore the Serving MSC waits until ...
- f. The Serving MSC receives an indication that the MS is available for alerting (e.g., an MS access is received).
- g. The Serving MSC may send a **REGNOT** to the VLR to notify it of the MS's presence.
- h. The VLR may send a **REGNOT** to the HLR to notify it of the MS's presence.
- i. The HLR returns a **regnot** to the VLR.

Additional Parameters	Usage	Type
MWNTYPE	Indicates that MWN Alert Pip Tone notification is required.	O

- 27
28
29
30
31
32
- j. The VLR returns a **regnot** to the Serving MSC.

Additional Parameters	Usage	Type
MWNTYPE	Indicates that MWN Alert Pip Tone notification is required.	O

- 33
34
35
36
37
38
39
40
41
42
43
44
45
46
47
48
49
50
51
52
53
54
55
56
57
58
59
60
- k. The Serving MSC then provides a MWN Alert Pip Tone to the MS.

6.13.4 MWN via an MS Indication or Message Count or Both

This scenario describes message waiting notification via the MS indication or message count options.

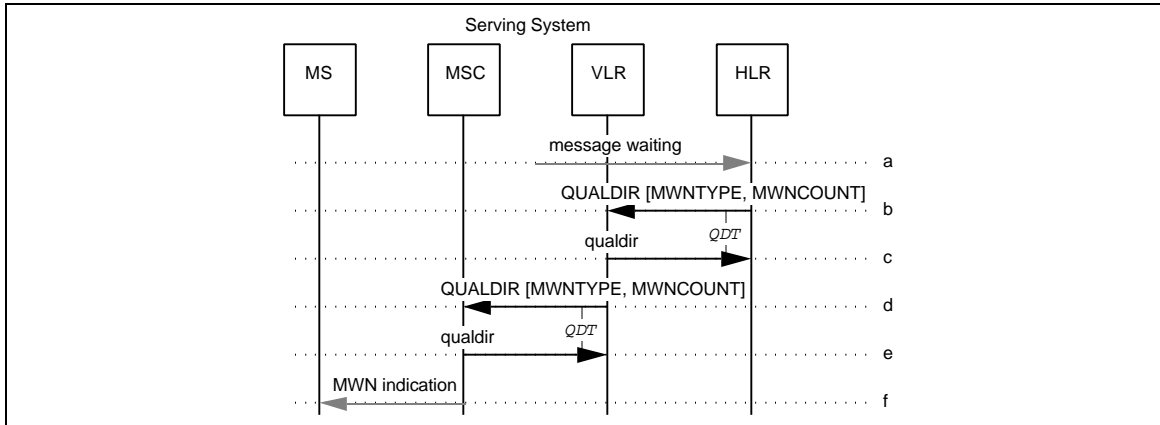

Figure 160 MWN via an MS Indication and/or MS Count

- a. The HLR is notified that there is a message waiting for a served MS.
- b. The HLR reports the change in the MS's MWN status by sending a `QUALDIR` to the VLR where the MS is registered.

Additional Parameters	Usage	Type
MWNTYPE	Indicates that notification via Message Waiting Indication or Count Indication or both is required.	R
MWNCOUNT	Indicates the type and number of messages waiting. Include if Count Indication requested in MessageWaitingNotification-Type parameter.	O

- c. The VLR sends a `qualdir` to the MSC.
- d. The VLR reports the change in the MS's MWN status by sending a `QUALDIR` to the Serving MSC. Additional parameters are as in Step -b.
- e. The Serving MSC sends a `qualdir` to the MS.
- f. The Serving MSC notifies the served MS of the change in the MS's MWN status via the appropriate notification method (i.e., Message Waiting Indication, Count Indication, or both).

6.13.5 MWN After Handoff

This scenario describes message waiting notification after intersystem handoff. Notification may be via the Message Waiting Indication method, or the Count Indication method.

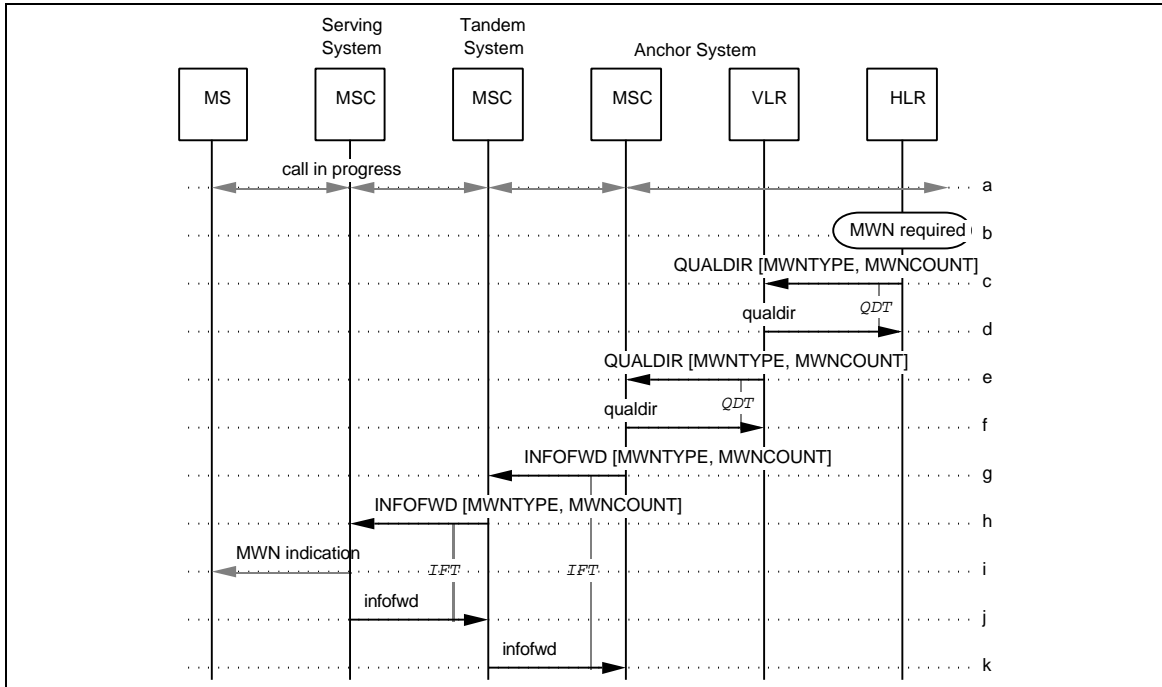

Figure 161 MWN After Handoff

- a. A call involving the served MS is in progress.
- b. The HLR determines that MWN is required for the served MS.
- c-f. Same as MWN, Section 6.13.4, steps b-e, respectively.
- g. The Anchor MSC sends an `INFOFWD [MWNTYPE, MWNCOUNT]` to the Tandem MSC, including the MWN information.
- h. The Tandem MSC adjusts the `InterMSCCircuitID` to identify the circuit between it and the Serving MSC, and forwards the `INFOFWD` to the Serving MSC.
- i. The Serving MSC presents the MWN indication to the served MS in an appropriate fashion.
- j. The Serving MSC acknowledges receipt by sending an `infofwd` to the Tandem MSC.
- k. The Tandem MSC forwards the `infofwd` to the Anchor MSC.

6.13.6 MWN via Pip Tone on MS Call Origination

This scenario describes the origination of a call by the served MS with MWN pending (pip tone option).

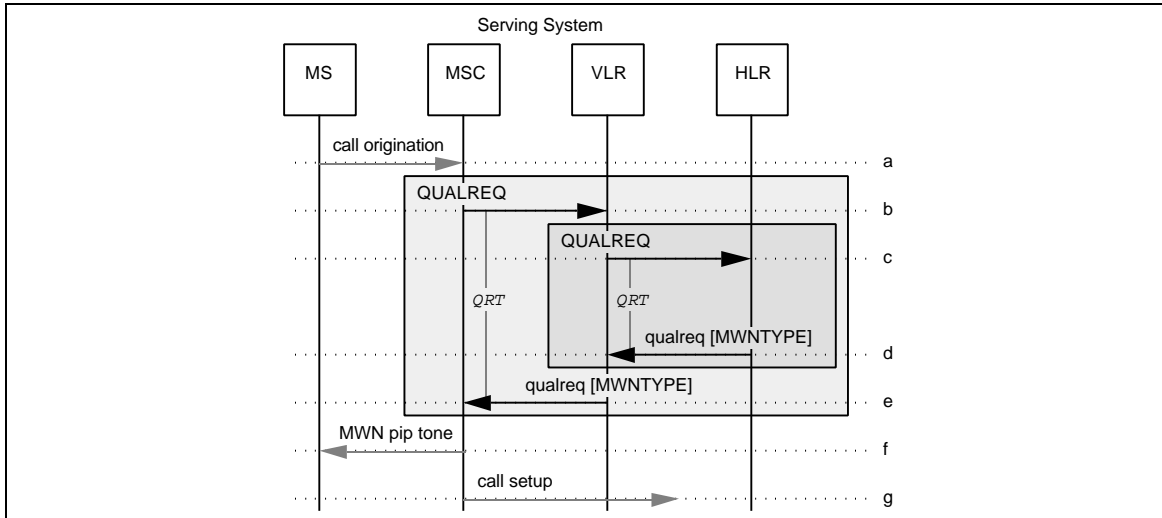

Figure 162 MWN via Pip Tone on MS Call Origination

- a. The Serving MSC receives a call origination from the served MS.
- b. If the service profile of the MS is unknown to the MSC, it sends a QUALREQ to the VLR.
- c. If the service profile of the MS is unknown to the VLR, it sends a QUALREQ to the HLR associated with the MS.
- d. The HLR sends a **qual req** to the Serving MSC's VLR, including an indication of the MS's MWN pending status.

Additional Parameters	Usage	Type
MWNTYPE	Indicates that MWN Pip Tone notification is required.	O

- e. The VLR sends a **qual req** to the Serving MSC, including the indication of the MS's MWN pending status. Additional parameters are as in Step -d.
- f. The Serving MSC notifies the served MS of the MS's MWN pending status via MWN pip tone.
- g. The Serving MSC extends the call.

6.13.7 MWN via Pip Tone on MS Termination

This scenario describes the termination of a call to the served MS with MWN pending (pip tone option).

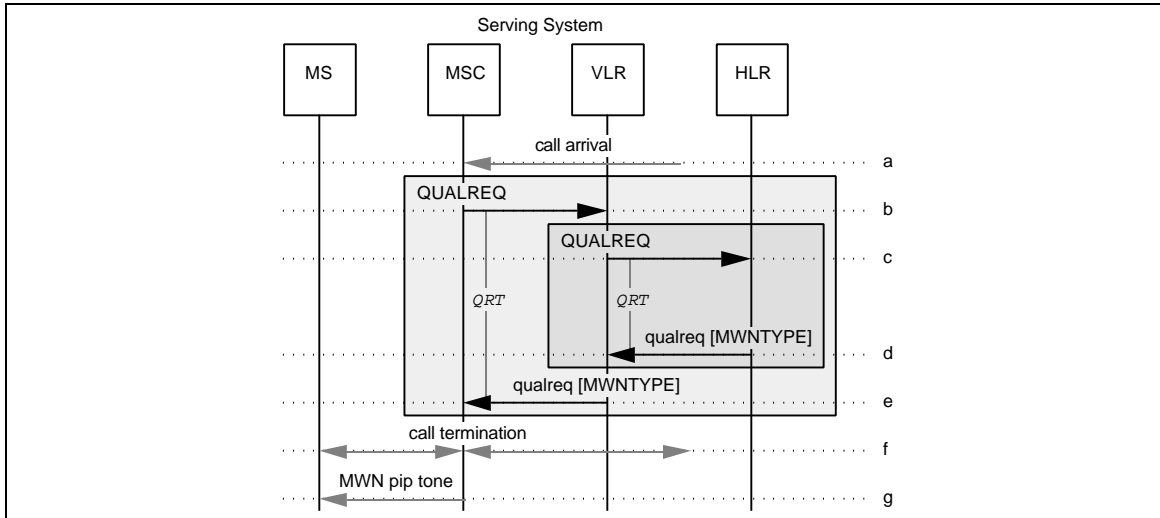

Figure 163 MWN via Pip Tone on MS Termination

- The Serving MSC receives a call termination for the served MS.
- If the service profile of the MS is unknown to the MSC, it sends a QUALREQ to the VLR.
- If the service profile of the MS is unknown to the VLR, it sends a QUALREQ to the HLR associated with the MS.
- The HLR sends a **qual req** to the Serving MSC's VLR, including an indication of the MS's MWN pending status.

Additional Parameters	Usage	Type
MWNTYPE	Indicates that MWN Pip Tone notification is required.	O

- The VLR sends a **qual req** to the Serving MSC, including the indication of the MS's MWN pending status. Additional parameters are as in Step -d.
- The call termination then proceeds.
- The Serving MSC notifies the served MS of the MS's MWN pending status via MWN pip tone.

6.14 Mobile Access Hunting

This section depicts the interactions between network entities in various situations related to automatic roaming and Mobile Access Hunting (MAH). These scenarios are for illustrative purposes only.

6.14.1 MAH Membership Activation or De-Activation

The information flows required for the activation or de-activation of membership in the member's default or specified MAH group by an authorized MS are described in Section 5.5.1.

6.14.2 MAH Ordering Change Request

The information flows required for a request to change the member's order in its default or specified MAH group, by an authorized MS, are described in Section 5.5.1.

6.14.3 MAH Invocation

This scenario describes the invocation of MAH. The MAH group is comprised of three members: one member is a PSTN DN, MAH-DN1; the other two members are MINs, MIN1 and MIN2, served by the same HLR and currently served by the same MSC.

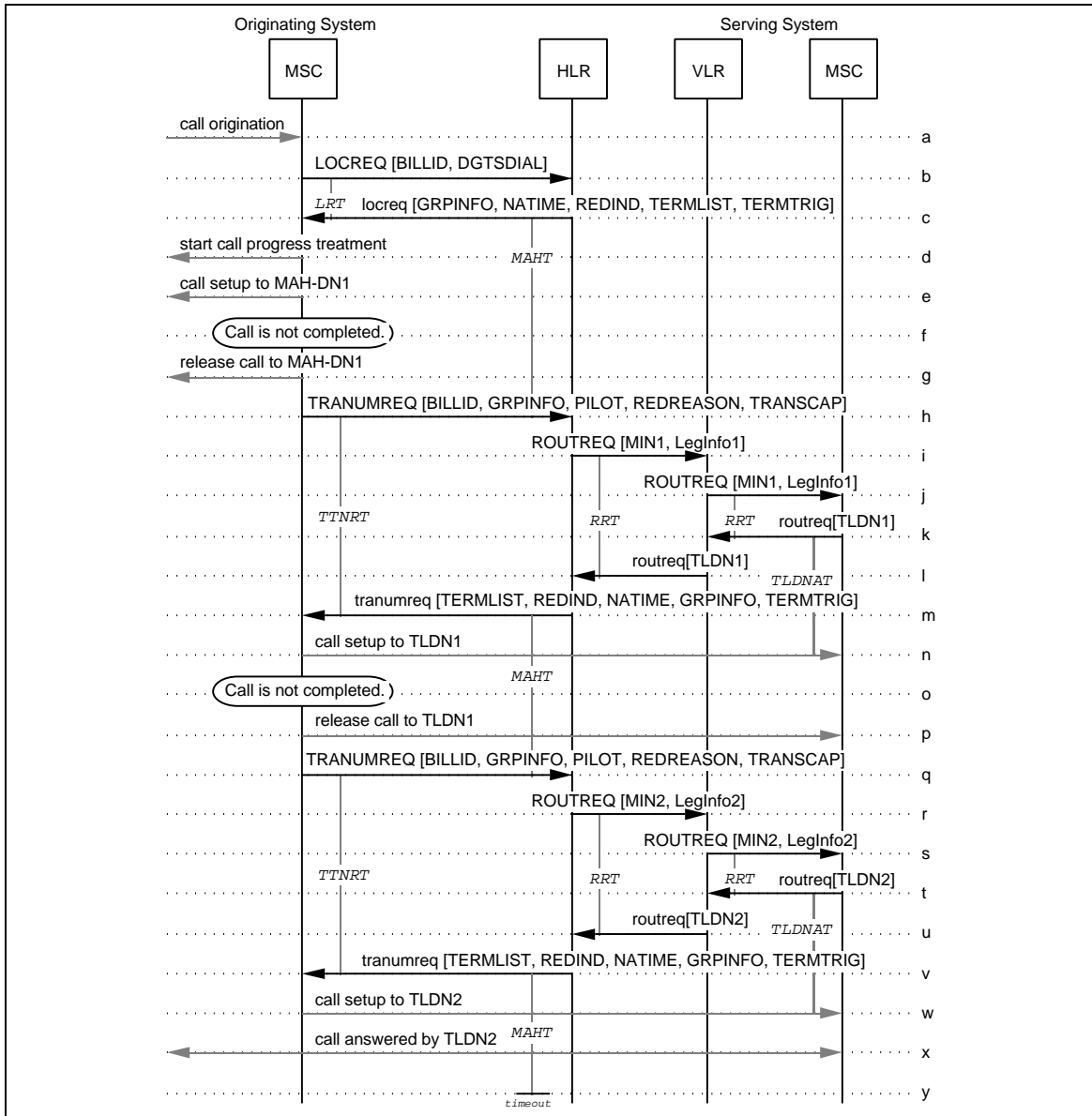

Figure 164 MAH Invocation

- 1
2
3
4
5
6
7
8
9
10
11
12
13
14
- a. A call origination and the dialed MS address digits (i.e., directory number) are received by the Originating MSC.
 - b. The Originating MSC sends a **LOCREQ** to the MS's HLR and includes the **BillingID** and **Digits (Dialed)** parameters.
 - c. The HLR recognizes the called number as an MAH Pilot DN. The HLR sends a **locreq** to the Originating MSC, containing the first MAH group member's routing information in the form of the **TerminationList** parameter, along with an indication of the reason for extending the incoming call (i.e., for MAH) in the **DMH_RedirectionIndicator** parameter.

15
16
17
18
19
20
21
22
23
24

Additional Parameters	Usage	Type
GRPINFO	Information associated with the MAH Pilot DN.	O
NATIME	Indication of how long, in seconds, the Originating MSC should wait before applying no answer treatment. Include to override Originating MSC default.	O
TERMTRIG	Indicates active termination trigger points for members not having TerminationTriggers inside the TerminationList .	O

- 25
26
27
28
29
30
31
32
33
34
35
36
37
38
39
40
41
42
- d. On receipt of the **locreq**, the Originating MSC may start call progress treatment to the calling party, if it has not already done so.
 - e. The Originating MSC provides call treatment as indicated in the **locreq**. In this case, the treatment is to attempt to establish a call to the first DN in the MAH group, MAH-DN1. For each call attempt, the Originating MSC monitors call progress; based on this information, it applies appropriate call progress treatment to the calling party.
 - f. The call to MAH-DN1 is not completed due to busy, no answer time-out or other causes.
 - g. The Originating MSC releases the call to MAH-DN1.
 - h. Based on the instructions in the **TerminationTriggers** parameter received in Step -c, the Originating MSC sends a **TRANUMREQ** to the HLR, containing the **BillingID** associated with the original MAH call (step b) and the **RedirectionReason** parameter.

43
44
45
46
47
48
49
50
51
52
53
54

Additional Parameters	Usage	Type
BILLID	May be used by HLR to relate the transfer request to the original MAH call invocation.	R
PILOT	May be used by the HLR to relate the transfer request to the original MAH invocation.	R
GRPINFO	May be used by HLR for further processing of the MAH call. Include if available.	O
TRANSCAP	Indicates the Originating MSC's transaction capability at the current time. (Allow routing information.)	O

- 55
56
57
58
59
60
- i. The HLR may use the **BillingID** or the **PilotNumber** and **LegInformation** to relate the transfer request to the original MAH call. It sends a **ROUTREQ** to the VLR where the MS corresponding to the next entry in the MAH group list is registered, that of MIN1.

Additional Parameters	Usage	Type
LegInfo1:	MAH parameters for call leg to MIN1:	
[AlertCode]	Include for distinctive alerting of MS.	O
[LegInformation]	Used for HLR identification of call leg to MIN1. Include at HLR option.	O
[OneTimeFeature-Indicator]	Modify feature processing for the duration of this call leg.	O
[TerminationTriggers]	Include if termination trigger points are active for call leg.	O

- j. The VLR forwards the **ROUTREQ** to the current Serving MSC.
- k. In reaction to the **ROUTREQ**, the Serving MSC checks its internal data structures and determines that the MS is currently idle. The Serving MSC allocates **TLDN1** and returns this information to the VLR in a **routreq**.
- l. The VLR sends the **routreq** to the HLR.
- m. The HLR sends a **tranumreq** to the Originating MSC, including **TLDN1** in the **TerminationList** parameter, along with an indication of the reason for extending the incoming call (i.e., for MAH) in the **DMH_RedirectionIndicator** parameter.

Additional Parameters	Usage	Type
GRPINFO	See description in Step-c.	O
NATIME	See description in Step-c.	O
TERMTRIG	See description in Step-c.	R

- n. The Originating MSC provides call treatment as indicated in the **tranumreq**. In this case, the treatment is to attempt to establish a call to **TLDN1**.
- o. The call to **TLDN1** is not completed due to busy, no answer time-out or other causes.
- p. The Originating MSC releases the call to **TLDN1**.
- q. Based on the instructions in the **TerminationTriggers** parameter received in Step -c, the Originating MSC sends a **TRANUMREQ** to the HLR, containing the **BillingID** associated with the original MAH call (step b) and the **RedirectionReason** parameter.

Additional Parameters	Usage	Type
BILLID	See description in Step-h.	R
PILOT	See description in Step-h.	R
GRPINFO	See description in Step-h.	O
TRANSCAP	See description in Step-h.	O

- r. The HLR may use the BillingID or PilotNumber and GroupInformation to relate the transfer request to the original MAH call. It sends a **ROUTREQ** to the VLR where the MS corresponding to the next entry in the MAH group list is registered, that of MIN2.

Additional Parameters	Usage	Type
LegInfo2:	MAH parameters for call leg to MIN2:	
[AlertCode]	See description in Step-i.	O
[LegInformation]	Used for HLR identification of call leg to MIN2. Include at HLR option.	O
[OneTimeFeature-Indicator]	Modify feature processing for the duration of this call leg.	O
[TerminationTriggers]	See description in Step-i.	O

- s. The VLR forwards the **ROUTREQ** to the current Serving MSC.
- t. In reaction to the **ROUTREQ**, the Serving MSC checks its internal data structures and determines that the MS is currently idle. The Serving MSC allocates TLDN2 and returns this information to the VLR in a **roureq**.
- u. The VLR sends the **roureq** to the HLR.
- v. The HLR sends a **tranumreq** to the Originating MSC, including TLDN2 in the TerminationList parameter, along with an indication of the reason for extending the incoming call (i.e., for MAH) in the DMH_RedirectionIndicator parameter.

Additional Parameters	Usage	Type
GRPINFO	See description in Step-c.	O
NATIME	See description in Step-c.	O
TERMTRIG	See description in Step-c.	R

- w. The Originating MSC provides call treatment as indicated in the **tranumreq**. In this case, the treatment is to attempt to establish a call to TLDN2.
- x. The party at TLDN2 answers. The Originating MSC connects the calling party to the party at TLDN2.
- y. On MAHT timer time-out, the HLR concludes MAH processing.

1
2
3
4 **6.14.4 MAH Invocation with a Busy MAH Group Member**
5 **(Single-User Type)**
6

7 This scenario describes an invocation of MAH where a member busy condition is
8 encountered. The MAH group is comprised of MINs. The MAH group is the single-user
9 type (i.e., the MAH group is considered busy when a member of the MAH group is busy).
10

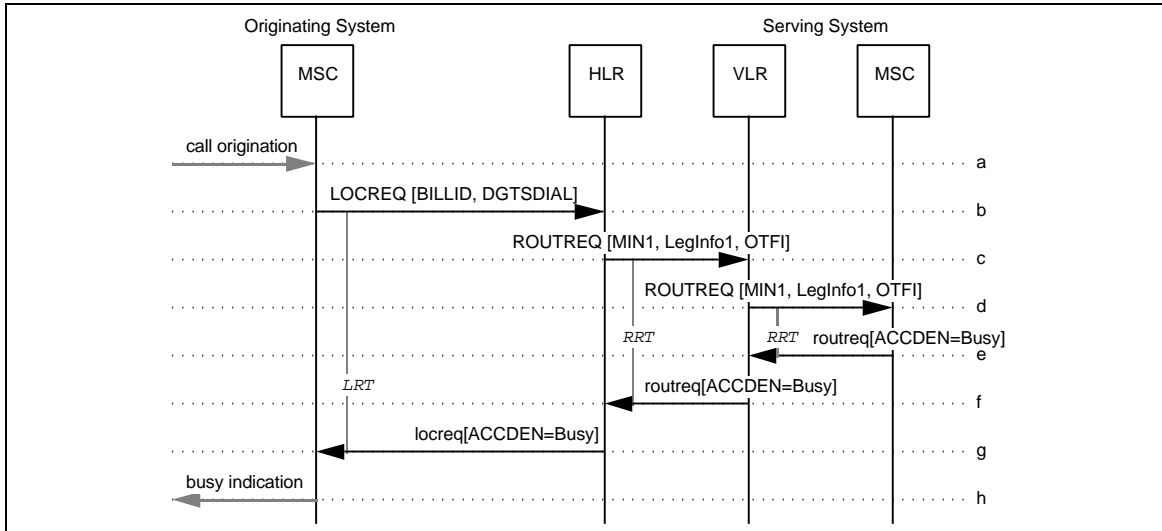

11
12
13
14
15
16
17
18
19
20
21
22
23
24
25
26
27
28
29 **Figure 165 MAH Invocation with a Busy MAH Group Member**
30 **(Single-User Type)**
31

a-b. Same as MAH, Section 6.14.3, Steps a-b.

c-d. Same as MAH, Section 6.14.3, Steps i-j, respectively.

Parameters are as in Section 6.14.3, Steps i-j, with the following addition:		
Parameters	Usage	Type
OTFI (Next Call) [OneTimeFeature- Indicator]	Modify feature processing for duration of next call received by MS. Include if applicable.	O

- e. In reaction to the **ROUTREQ**, the Serving MSC checks its internal data structures and determines that the MS is currently busy. The Serving MSC returns this information to the VLR in a **routreq**.
- f. The VLR sends the **routreq** to the HLR.
- g. The HLR determines from the service profile that the MAH group is a single-user type; therefore, the group is considered busy (i.e., since MIN1 is busy). The HLR returns the busy status to the Originating MSC in the **locreq**.
- h. The Originating MSC then returns a busy indication to the calling party. Note that failure on this call will not generate any MAH-specific feature processing.

6.14.5 MAH Invocation with a Busy MAH Group Member (Multiple-User Type)

This scenario describes an invocation of MAH where a member busy condition is encountered. The MAH group is comprised of MINs. The MAH group is the multiple-user type (i.e., the MAH group is considered busy when all accessible members of the MAH group are busy).

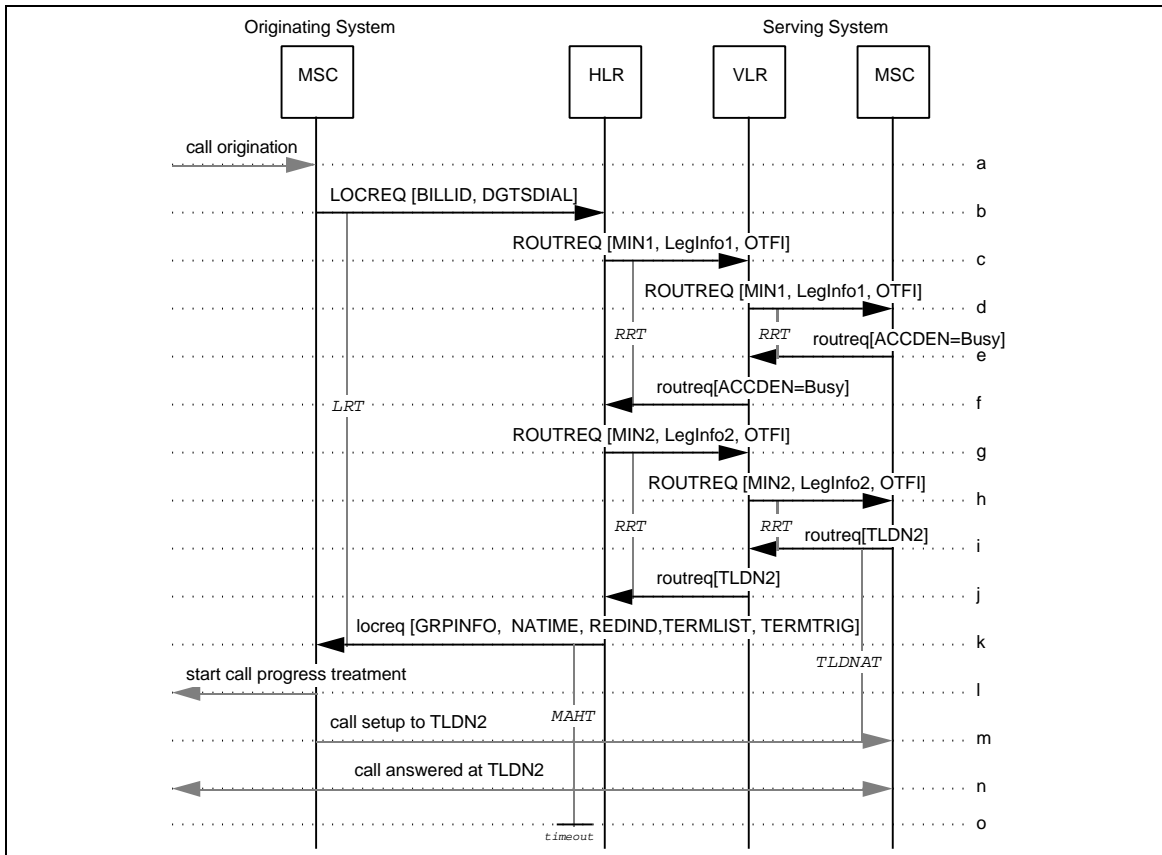

Figure 166 MAH Invocation with a Busy MAH Group Member (Multiple-User Type)

- 1
2
3
4
5
6
7
8
9
- a-f. Same as MAH, Section 6.14.4, Steps a-f.
- g. The HLR determines from the service profile that the MAH group is a multiple-user type; therefore, the group is not considered busy even though MIN1 is busy. Therefore, the HLR skips over MIN1 to the next entry in the MAH group, MIN2. It sends a ROUTREQ to the VLR where the MS corresponding to MIN2 is registered.

10
11
12
13
14
15
16
17
18
19
20
21
22
23

Parameters are as in Section 6.14.3, Step r, with the following addition:		
Parameters	Usage	Type
LegInfo2:	MAH parameters for call leg to MIN1:	
[AlertCode]	Include for distinctive alerting of MS.	O
[LegInformation]	Used for HLR identification of call leg. Include at HLR option.	O
[TerminationTriggers]	Include if termination trigger points are active for call leg.	O
OTFI (Next Call) [OneTimeFeature-Indicator]	Modify feature processing for duration of next call received by MS. Include if applicable.	O

- 24
25
26
27
28
29
30
31
32
33
34
- h. The VLR forwards the ROUTREQ to the current Serving MSC.
- i. In reaction to the ROUTREQ, the Serving MSC checks its internal data structures and determines that the MS is currently idle. The Serving MSC allocates TLDN2 and returns this information to the VLR in a routreq.
- j. The VLR sends the routreq to the HLR.
- k. The HLR sends a locreq to the Originating MSC, including TLDN2 in the TerminationList parameter, along with an indication of the reason for extending the incoming call (i.e., for MAH) in the DMH_RedirectionIndicator parameter.

35
36
37
38
39
40
41
42
43
44
45
46

Additional Parameters	Usage	Type
GRPINFO [GroupInformation]	Information associated with the MAH Pilot DN.	O
NATIME [NoAnswerTime]	Indication of how long, in seconds, the Originating MSC should wait before applying no answer treatment. Include to override Originating MSC default.	O
TERMTRIG [TerminationTriggers]	Indicates active termination trigger points for members not having TerminationTriggers inside the TerminationList.	O

- 47
48
49
50
51
52
53
54
55
56
57
58
59
60
- l. On receipt of the locreq, the Originating MSC may start call progress treatment to the calling party, if it has not already done so.
- m. The Originating MSC provides call treatment as indicated in the locreq. In this case, the treatment is to attempt to establish a call to TLDN2.
- n. The party at TLDN2 answers. The Originating MSC connects the calling party to the party at TLDN2.
- o. On MAHT timer time-out, the HLR concludes MAH processing.

6.14.6 MAH Invocation with a No Answer MAH Group Member

This scenario describes an invocation of MAH where a member no answer condition is encountered. The MAH group is comprised of MINs.

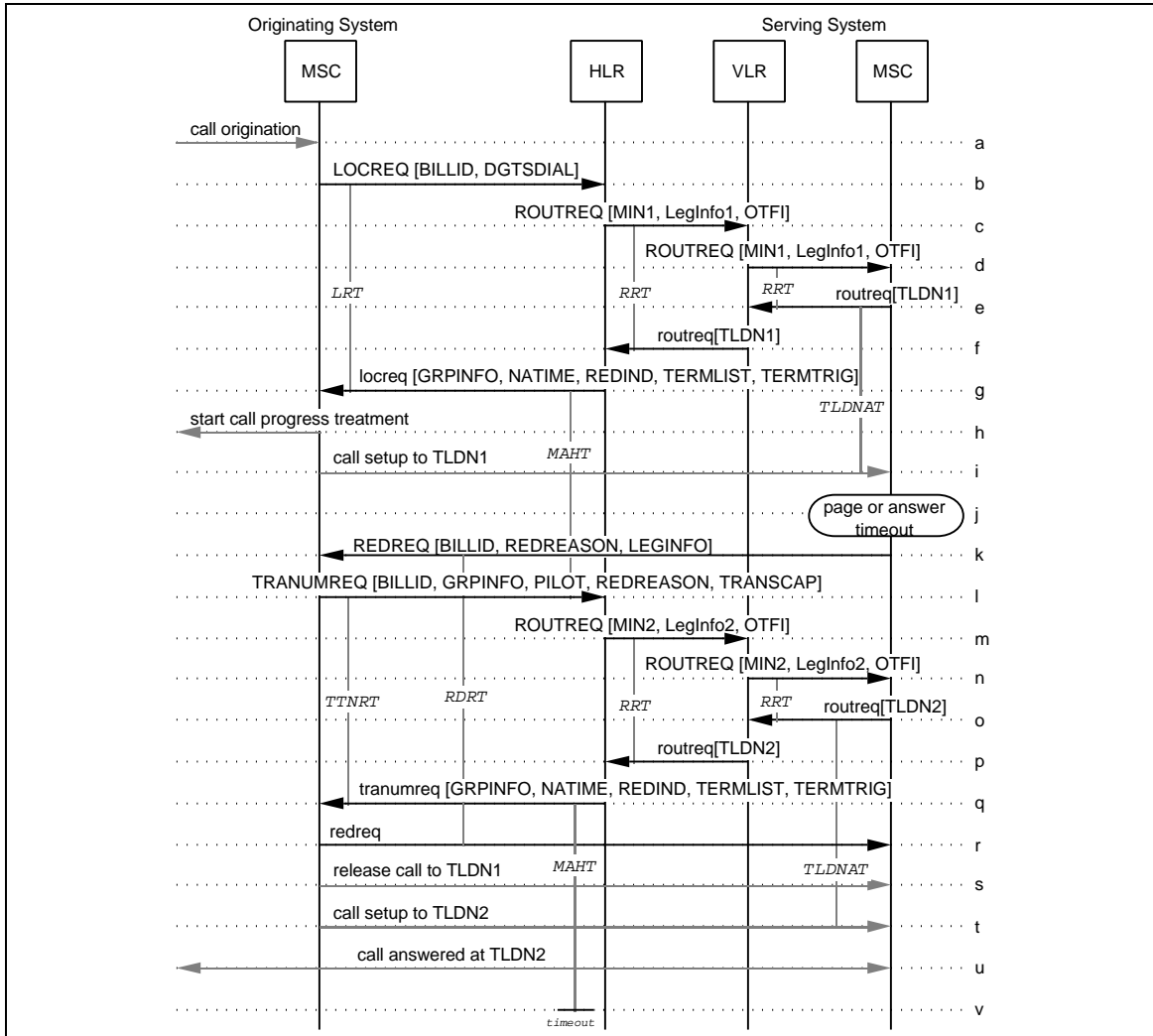

Figure 167 MAH Invocation with a No Answer MAH Group Member

- 1
2
3
4
5
6
7
8
9
10
11
12
13
- a-d. Same as MAH, Section 6.14.5, Steps a-d.
 - e. In reaction to the **ROUTREQ**, the Serving MSC checks its internal data structures and determines that the MS is currently idle. The Serving MSC allocates TLDN1 and returns this information to the VLR in a **routreq**.
 - f. The VLR sends the **routreq** to the HLR.
 - g. The HLR sends a **locreq** to the Originating MSC, including TLDN1 in the TerminationList parameter, along with an indication of the reason for extending the incoming call (i.e., for MAH) in the DMH_RedirectionIndicator parameter.

14
15
16
17
18
19
20
21
22
23
24
25

Additional Parameters	Usage	Type
GRPINFO [GroupInformation]	Information associated with the MAH Pilot DN.	O
NATIME [NoAnswerTime]	Indication of how long, in seconds, the Originating MSC should wait before applying no answer treatment. Include to override Originating MSC default.	O
TERMTRIG [TerminationTriggers]	Indicates active termination trigger points for members not having TerminationTriggers inside the TerminationList.	O

- 26
27
28
29
30
31
32
33
34
35
36
37
38
39
40
41
42
43
44
45
46
47
48
49
50
51
52
53
54
55
56
57
58
59
60
- h. On receipt of the **locreq**, the Originating MSC may start call progress treatment to the calling party, if it has not already done so.
 - i. The Originating MSC provides call treatment as indicated in the **locreq**. In this case, the treatment is to attempt to establish a call to TLDN1.
 - j. When the call for MIN1 is received at the Serving MSC, the MS is paged and, if a page response is received, subsequently alerted. The MS fails to respond to the page or does not answer after alerting; the Serving MSC determines from the service profile (including the profile overrides based on the TerminationTriggers parameter) that MIN1 has call forwarding active on no answer or no response to page conditions.
 - k. The Serving MSC sends a **REDREQ** containing the BillingID and RedirectionReason parameters to the Originating MSC, indicating that the call is being redirected due to a *no answer* or *no page response* condition.

Additional Parameters	Usage	Type
LEGINFO	LegInformation. Used for HLR identification of call leg to MIN1. Include if available.	O

- l. If the Originating MSC is able to redirect the call, it sends a TRANUMREQ to the HLR requesting the forward-to number appropriate for the *no answer* or *no page response* condition from the MS's service profile. Refer to Section 6.2.5 for procedures if the Originating MSC is not able to redirect the call.

Additional Parameters	Usage	Type
BILLID	BillingID. Used by HLR to relate the transfer request to the original MAH call invocation.	R
PILOT	May be used by the HLR to relate the transfer request to the original MAH invocation.	R
REDREASON	Indicates the reason for requesting a transfer-to number	R
GRPINFO	May be used by HLR for further processing of the MAH call. Include if available.	O
TRANSCAP	Indicates the Originating MSC's transaction capability at the current time.	O

- m. The HLR may use the BillingID or the PilotNumber and GroupInformation to relate the transfer request to the original MAH call. The HLR sends a ROUTREQ to the VLR where the MS corresponding to MIN2 is registered.

Parameters are as in Section 6.14.3, Step r, with the following addition:		
Parameters	Usage	Type
LegInfo2:	MAH parameters for call leg to MIN2:	
[AlertCode]	Include for distinctive alerting of MS.	O
[LegInformation]	Used for HLR identification of call leg. Include at HLR option.	O
[TerminationTriggers]	Include if termination trigger points are active for call leg.	O
OTFI (Next Call) [OneTimeFeature-Indicator]	Modify feature processing for duration of next call received by MS. Include if applicable.	O

- n. The VLR forwards the ROUTREQ to the current Serving MSC.
- o. In reaction to the ROUTREQ, the Serving MSC checks its internal data structures and determines that the MS is currently idle. The Serving MSC allocates TLDN2 and returns this information to the VLR in a routreq.
- p. The VLR sends the routreq to the HLR.

- 1
2
3
4
5
6
7
8
- q. The HLR sends a **tr anumreq** to the Originating MSC, including the appropriate forward-to number in the TerminationList parameter, along with an indication of the reason for extending the incoming call (i.e., for CFNA) in the DMH_RedirectionIndicator parameter.

Additional Parameters	Usage	Type
GRPINFO	See description in Step-g.	O
NATIME	See description in Step-g.	O
TERMTRIG	See description in Step-g.	R

- 9
10
11
12
13
14
15
16
17
18
19
20
21
22
23
24
25
26
27
28
29
30
31
32
33
34
35
36
37
38
39
40
41
42
43
44
45
46
47
48
49
50
51
52
53
54
55
56
57
58
59
60
- r. When the **tr anumreq** is received from the HLR, the Originating MSC sends a **redreq** to the Serving MSC.
- s. The Originating MSC releases the call to TLDN1.
- t. The Originating MSC attempts to establish a call to TLDN2.
- u. The party at TLDN2 answers. The Originating MSC connects the calling party to the party at TLDN2.
- v. On MAHT timer time-out, the HLR concludes MAH processing.

6.14.7 MAH Invocation on Revertive Call to MAH Pilot DN

This scenario describes the invocation of MAH when the call is originated by a member of the MAH group whose MIN is the MAH Pilot-DN. The other (two) termination addresses in the MAH group are directory numbers (DNs). An ORREQ is used because the *Revertive Call* trigger in the OriginationTriggers parameter is set.

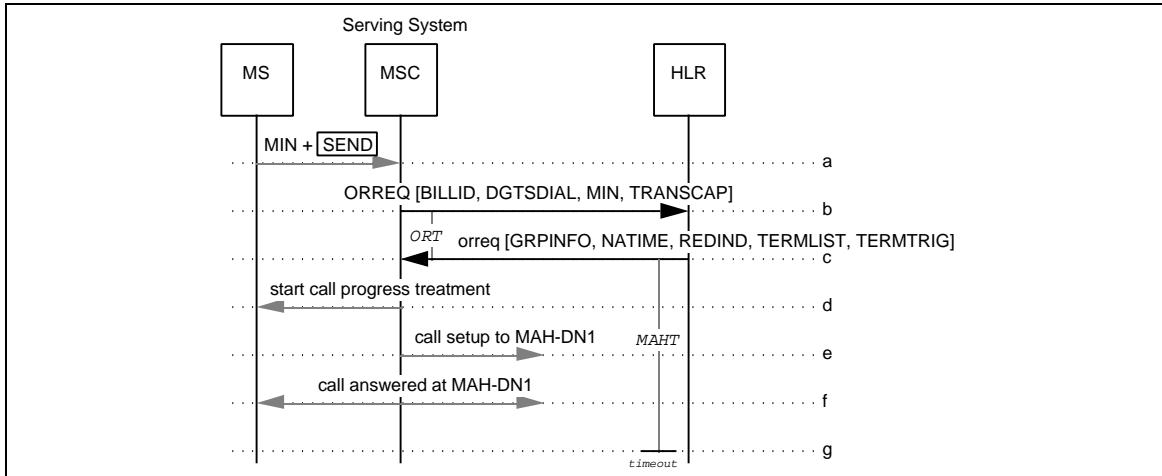

Figure 168 MAH Invocation on Revertive Call to MAH Pilot DN

- 1
2
3
4
5
6
7
8
9
- a. Dialed digits are received by the Serving MSC. The Serving MSC detects that the dialed digits correspond to the served MS's MIN.
- b. The Digits Dialed are included in a **ORREQ** and sent from the Serving MSC to the HLR associated with the MS.

Additional Parameters	Usage	Type
BILLID	BillingID. Used by HLR to relate the transfer request to the original MAH call invocation.	R
MIN	Mobile Identification Number.	R
TRANSCAP	Indicates the Originating MSC's transaction capability at the current time.	O

- 10
11
12
13
14
15
16
17
18
19
20
21
22
23
24
25
- c. The HLR recognizes the called number as an MAH Pilot DN. The MAH group contains three numbers: the MAH PILOT-DN, MAH-DN1, and MAH-DN2. The HLR recognizes the calling party as the MAH PILOT-DN (based on the received MIN). Therefore, the HLR skips the MAH PILOT-DN and sends an **orreq** to the Originating MSC, containing the next MAH group member's routing information in the form of the TerminationList parameter, along with an indication of the reason for extending the incoming call (i.e., for MAH) in the DMH_RedirectionIndicator parameter.

Additional Parameters	Usage	Type
GRPINFO [GroupInformation]	Information associated with the MAH Pilot DN.	O
NATIME [NoAnswerTime]	Indication of how long, in seconds, the Originating MSC should wait before applying no answer treatment. Include to override Originating MSC default.	O
TERMTRIG [TerminationTriggers]	Indicates active termination trigger points for members not having TerminationTriggers inside the TerminationList.	O

- 26
27
28
29
30
31
32
33
34
35
36
37
38
39
40
41
42
43
44
45
46
47
48
49
50
51
52
53
54
55
56
57
58
59
60
- d. On receipt of the **orreq**, the Serving MSC may start call progress treatment to the calling party, if it has not already done so.
- e. The Serving MSC provides call treatment as indicated in the **orreq**. In this case, the treatment is to attempt to establish a call to the second member of the MAH group, MAH-DN1. For each call attempt, the Serving MSC monitors call progress; based on this information, it applies appropriate call progress treatment to the calling party.
- f. The party at MAH-DN1 answers. The Serving MSC connects the calling party to the party at MAH-DN1 and concludes MAH feature processing.
- g. On MAHT timer time-out, the HLR concludes MAH processing.

6.14.8 MAH Invocation on Call from MAH Group Member

This scenario describes the invocation of MAH when the call is originated by a member of the MAH group. The other (two) termination addresses in the MAH group are directory numbers (DNs). The MAH group is the multiple-user type (i.e., the MAH group is considered busy when all accessible members of the MAH group are busy).

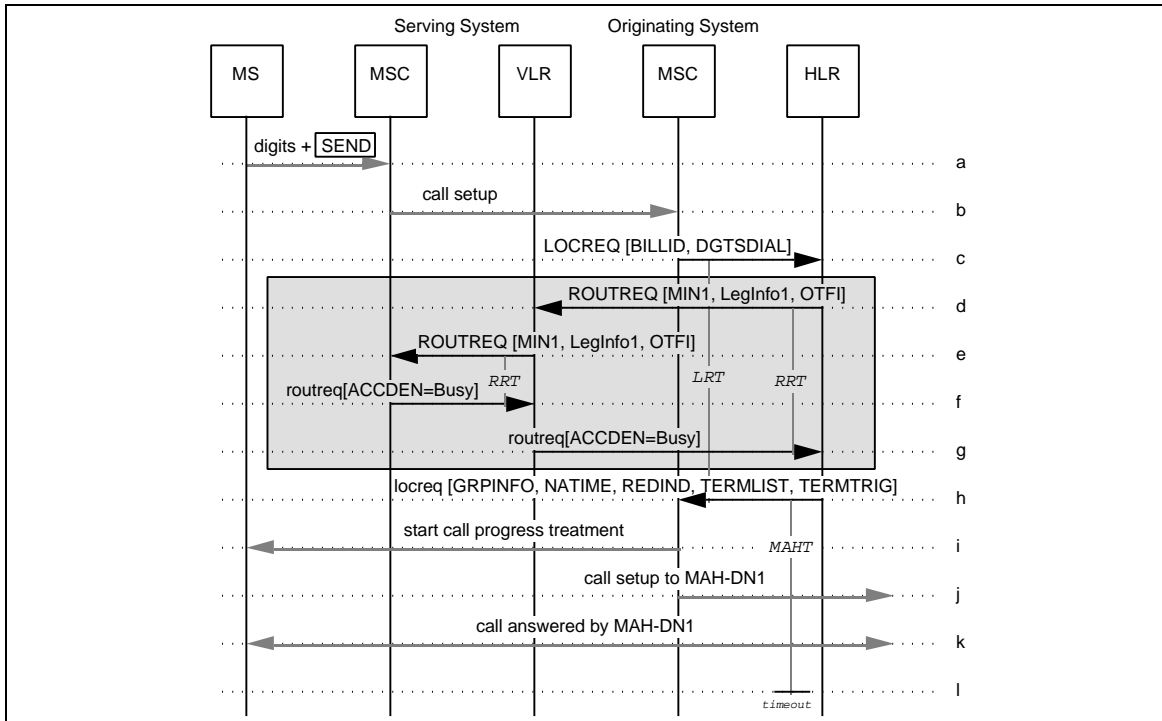

Figure 169 MAH Invocation on Call from MAH Group Member

- Dialed digits are received by the Serving MSC.
- The Serving MSC establishes an call to the Originating MSC.
- The Digits (Dialed) and BillingID parameters are included in a LOCREQ and sent from the Originating MSC to the HLR associated with the MS.

- d. The HLR recognizes the called number as an MAH Pilot DN. The MAH group contains three numbers: MIN1 (the MIN of MS1), MAH-DN1, and MAH-DN2. If the HLR is aware that the calling party is MS1 (e.g., via calling party number information in the call setup), it may skip to Step-h. Otherwise, the HLR constructs a ROUTREQ and sends it to the VLR where MS1 is registered.

Additional Parameters	Usage	Type
LegInfo1: [AlertCode] [LegInformation] [TerminationTriggers]	MAH parameters for call leg to MIN1: Include for distinctive alerting of MIN1. Used for HLR identification of call leg to MIN1. Include at HLR option. Include if termination trigger points are active for call leg to MIN1.	O O O
OTFI (Next Call) [OneTimeFeature-Indicator]	Modify feature processing for duration of next call received by MS. Include if applicable.	O

- e. The VLR forwards the ROUTREQ to the current Serving MSC.
- f. In reaction to the ROUTREQ, the Serving MSC checks its internal data structures and determines that the MS is busy in another call. The status of the MS is returned to the VLR by the Serving MSC in the routreq.
- g. The VLR sends the routreq to the HLR.
- h. Since MS1 is busy, and the MAH group is the multiple-user type (i.e., the MAH group is considered busy when all accessible members of the MAH group are busy), the HLR skips MS1 and sends a locreq to the Originating MSC, containing the next MAH group member's routing information in the form of the TerminationList parameter, along with an indication of the reason for extending the incoming call (i.e., for MAH) in the DMH_RedirectionIndicator parameter.

Additional Parameters	Usage	Type
GRPINFO [GroupInformation]	Information associated with the MAH Pilot DN.	O
NATIME [NoAnswerTime]	Indication of how long, in seconds, the Originating MSC should wait before applying no answer treatment. Include to override Originating MSC default.	O
TERMTRIG [TerminationTriggers]	Indicates active termination trigger points for members not having TerminationTriggers inside the TerminationList.	O

- i. On receipt of the locreq, the Originating MSC may start call progress treatment to the calling party, if it has not already done so.
- j. The Originating MSC provides call treatment as indicated in the locreq. In this case, the treatment is to attempt to establish a call to the second member of the MAH group, MAH-DN1. For each call attempt, the Originating MSC monitors call progress; based on this information, it applies appropriate call progress treatment to the calling party.

1
2
3
4
5
6
7
8
9
10
11
12
13
14
15
16
17
18
19
20
21
22
23
24
25
26
27
28
29
30
31
32
33
34
35
36
37
38
39
40
41
42
43
44
45
46
47
48
49
50
51
52
53
54
55
56
57
58
59
60

k. The party at MAH-DN1 answers. The Originating MSC connects the calling party to the party at MAH-DN1 and concludes MAH feature processing.

l. On MAHT timer time-out, the HLR concludes MAH processing.

6.15 Password Call Acceptance

This section depicts the interactions between network entities in various situations related to automatic roaming and Password Call Acceptance (PCA). These scenarios are for illustrative purposes only.

6.15.1 PCA Demand Activation or De-Activation

The information flows required for the demand activation or de-activation of PCA by an authorized MS are described in Section 5.5.1.

6.15.2 PCA Variable Diversion Registration or De-Registration

The information flows required for the registration or de-registration of PCA variable diversion by an authorized MS are described in Section 5.5.1.

6.15.3 PCA Password Registration or De-Registration

The information flows required for the registration or de-registration of PCA variable number by an authorized MS are described in Section 5.5.1.

6.15.4 PCA Invocation with Call Accepted

This scenario describes the invocation of PCA for an authorized MS, with the result being call acceptance.

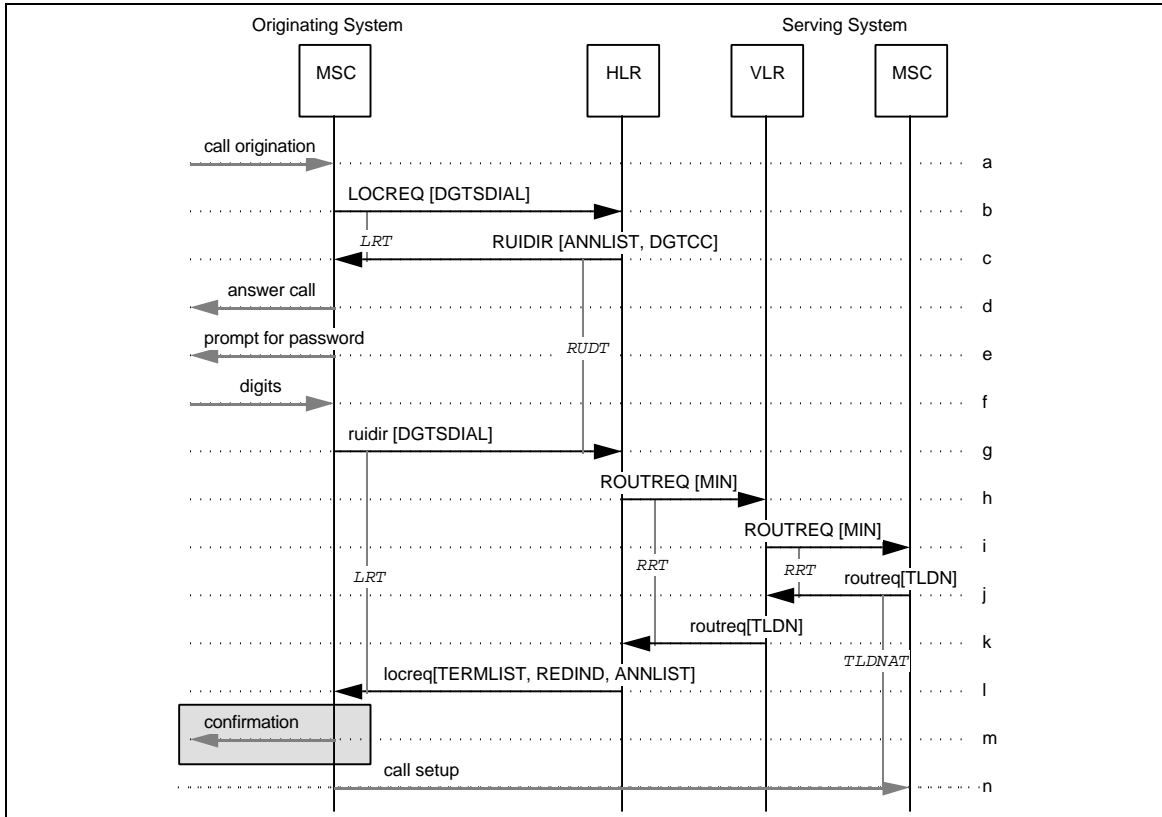

Figure 170 PCA Invocation with Call Accepted

- 1
2
3
4
5
6
7
8
9
10
11
12
13
14
15
16
17
18
19
20
21
22
23
24
25
26
27
28
29
30
31
32
33
34
35
36
37
38
39
40
41
42
43
44
45
46
47
48
49
50
51
52
53
54
55
56
57
58
59
60
- a. A call origination and the dialed MS address digits (i.e., directory number) are received by the Originating MSC.
 - b. The Originating MSC sends a `LOCREQ` to the MS's HLR.

The HLR determines from the MS's service profile that PCA is active; therefore, it initiates a user interaction session.
 - c. The HLR sends a `RUI DIR` to the Originating MSC.
 - d. On receipt of the `RUI DIR`, the Originating MSC turns off the `LOCREQ` timer and provides call treatment as indicated in the received message. In this case, the treatment is to answer the call (i.e., connect the calling party to subsystem capable of user interaction).
 - e. The Originating MSC prompts the user based on the information in the received `RUI DIR`, and wait for digits.
 - f. The user responds with its password digits.
 - g. The Originating MSC sends a `rui dir` to the HLR, containing the digits dialed by the user. The HLR checks the digits received against the PCA screening list for the called MS. In this scenario, the password is matched with an entry in the list; therefore, the call is allowed to proceed.
 - h. If the dialed MS address digits are assigned to a legitimate subscriber, the HLR sends a `ROUTREQ` to the VLR where the MS is registered.
 - i. The VLR then forwards the `ROUTREQ` to the current Serving MSC.
 - j. In reaction to the `ROUTREQ`, the Serving MSC checks its internal data structures and determines that the MS is currently idle. The Serving MSC allocates a TLDN and returns this information to the VLR in the `routeq`.
 - k. The VLR sends the `routeq` to the HLR.
 - l. When the `routeq` is received by the HLR, it returns a `locreq` to the Originating MSC. The `locreq` includes routing information in the form of the `TerminationList` parameter, along with an indication of the reason for extending the incoming call (i.e., for CD) in the `DMH_RedirectionIndicator` parameter. It also may include an `AnnouncementList` parameter, containing a PCA confirmation announcement to be provided to the calling party.
 - m. The Originating MSC provides call treatment as indicated in the `locreq`. In this case, the treatment is to, optionally, provide a confirmation announcement.
 - n. The Originating MSC establishes a voice path to the Serving MSC using existing interconnection protocols (e.g. SS7) and the routing information specified in the `locreq`.

6.15.5 PCA Invocation with Call Accepted: Alternate Procedure

This scenario describes an alternate procedure for the invocation of PCA for an authorized MS, with the result being call acceptance.

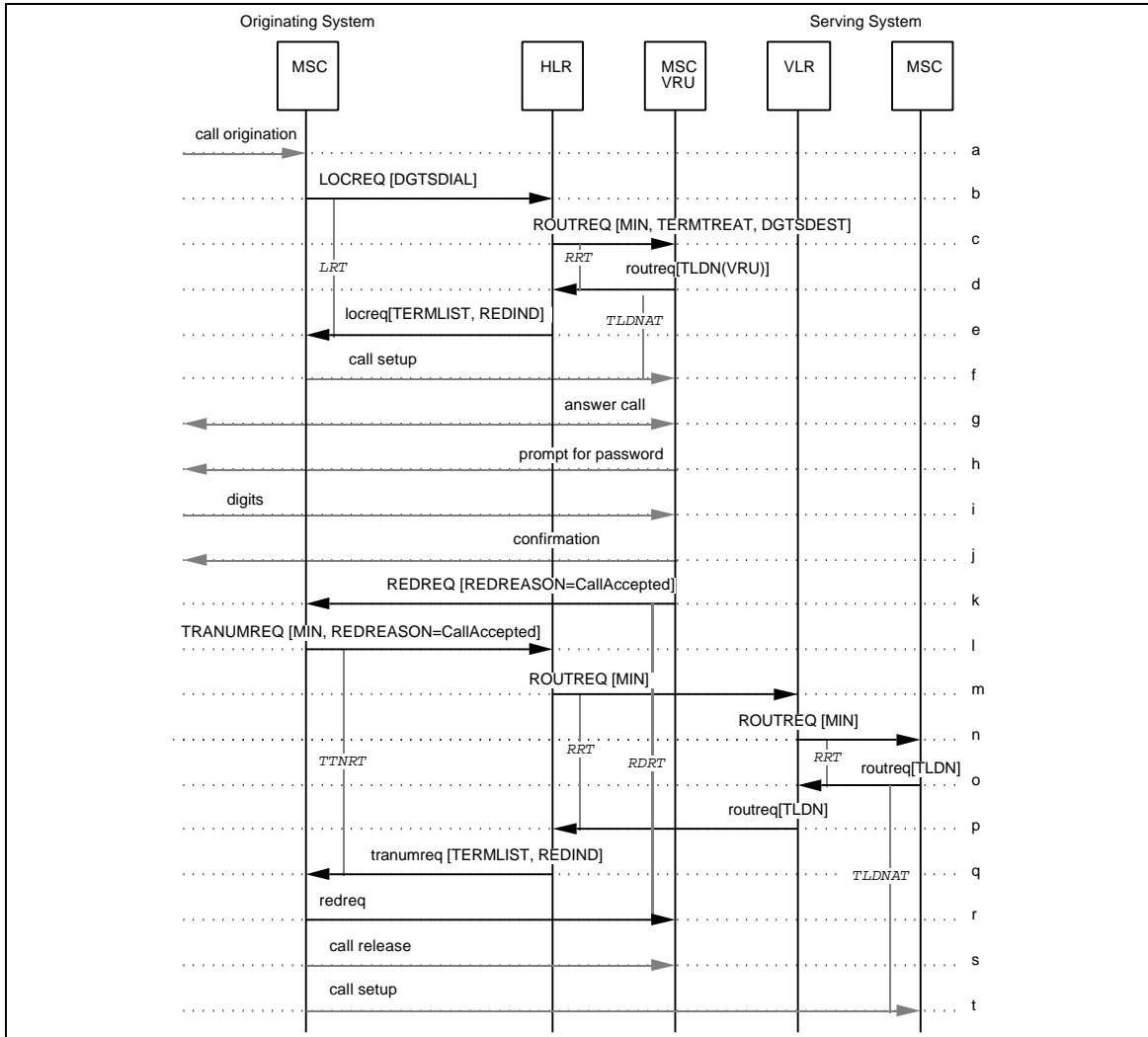

Figure 171 PCA Invocation with Call Accepted: Alternate Procedure

1
2
3
4
5
6
7
8
9
10
11
12
13
14
15
16
17
18
19
20
21
22
23
24
25
26
27
28
29
30
31
32
33
34
35
36
37
38
39
40
41
42
43
44
45
46
47
48
49
50
51
52
53
54
55
56
57
58
59
60

- a. A call origination and the dialed MS address digits (i.e., directory number) are received by the Originating MSC.
- b. The Originating MSC sends a **LOCREQ** to the MS's HLR.
- c. The HLR determines from the MS's service profile that PCA is active; therefore, it sends a **ROUTREQ** to an associated Voice Response Unit (MSC-VRU), including the called MIN and an indication that a PCA dialog is requested.
- d. The MSC-VRU allocates a TLDN and returns it to the HLR in a **routreq**.
- e. When the **routreq** is received by the HLR, it returns a **locreq** to the Originating MSC. The **locreq** includes routing information in the form of the TerminationList parameter, along with an indication of the reason for extending the incoming call (i.e., for PCA) in the DMH_RedirectionIndicator parameter.
- f. The Originating MSC provides call treatment as indicated in the **locreq**. In this case, the treatment is to establish a voice path to the MSC-VRU using existing interconnection protocols (e.g. SS7) and the routing information specified in the **locreq**.
- g-j. The calling party enters a dialog with the MSC-VRU that may include voice prompts and entry of responses through DTMF digits or spoken words. The dialog may be more complex than shown here, including retransmission of the password if necessary.
- k. The PCA dialog being successfully completed, the MSC-VRU initiates redirection by sending a **REDREQ** to the Originating MSC with the RedirectionReason set to *Call Accepted*.
- l. The Originating MSC sends a **TRANUMREQ** to the HLR requesting the routing information appropriate for the *Call Accepted* condition.
- m. The HLR sends a **ROUTREQ** to the VLR where the MS is registered.
- n. The VLR forwards the **ROUTREQ** to the current Serving MSC.
- o. In reaction to the **ROUTREQ**, the Serving MSC checks its internal data structures and determines that the MS is currently idle. The Serving MSC allocates a TLDN and returns this information to the VLR in a **routreq**.
- p. The VLR sends the **routreq** to the HLR.
- q. The HLR sends a **tranumreq** to the Originating MSC, including the TLDN in the TerminationList parameter, along with an indication of the reason for extending the incoming call (i.e., for CD) in the DMH_RedirectionIndicator parameter.
- r. When the **tranumreq** is received from the HLR, the Originating MSC sends a **redreq** to the MSC-VRU.
- s. The Originating MSC releases the inter-MS-C call.
- t. The Originating MSC initiates call setup to the TLDN.

6.15.6 PCA Invocation with Call Refused to Tone or Announcement

This scenario describes the invocation of PCA for an authorized MS, with the result being call refusal to a tone or announcement.

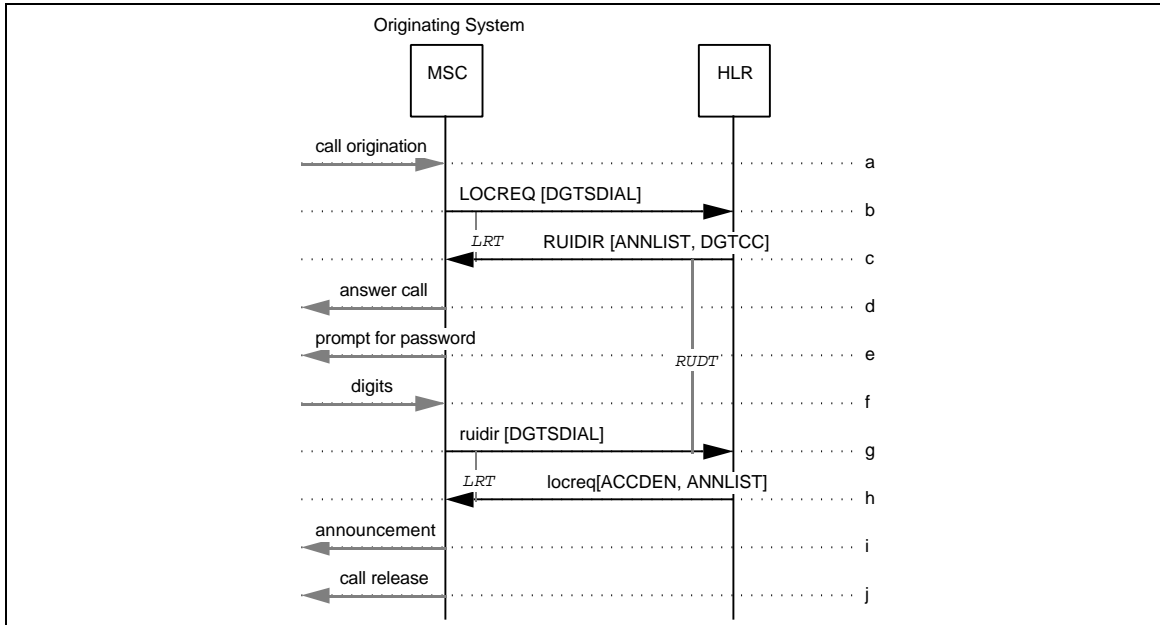

Figure 172 PCA Invocation with Call Refused to Tone or Announcement

- a-f. Same as PCA, Section 6.15.4, Steps a-f.
- g. The Originating MSC sends a `rui di r` to the HLR, containing the digits dialed by the user. The HLR checks the digits received against the PCA screening list for the called MS. In this scenario, the password is not matched with an entry in the list; therefore, the call is not allowed to proceed.
- h. The HLR returns a `locreq` to the Originating MSC, including the `AccessDeniedReason` parameter. The `locreq` may also include an `AnnouncementList` parameter indicating a particular announcement to be provided to the calling party.
- i. The Originating MSC provides call treatment as indicated in the `locreq`. In this case, the treatment is to apply a refusal announcement.
- j. The Originating MSC release the call.

6.15.7 PCA Invocation with Call Refused to Voice Mail

This scenario describes the invocation of PCA for an authorized MS, with the result being call refusal to a voice message system.

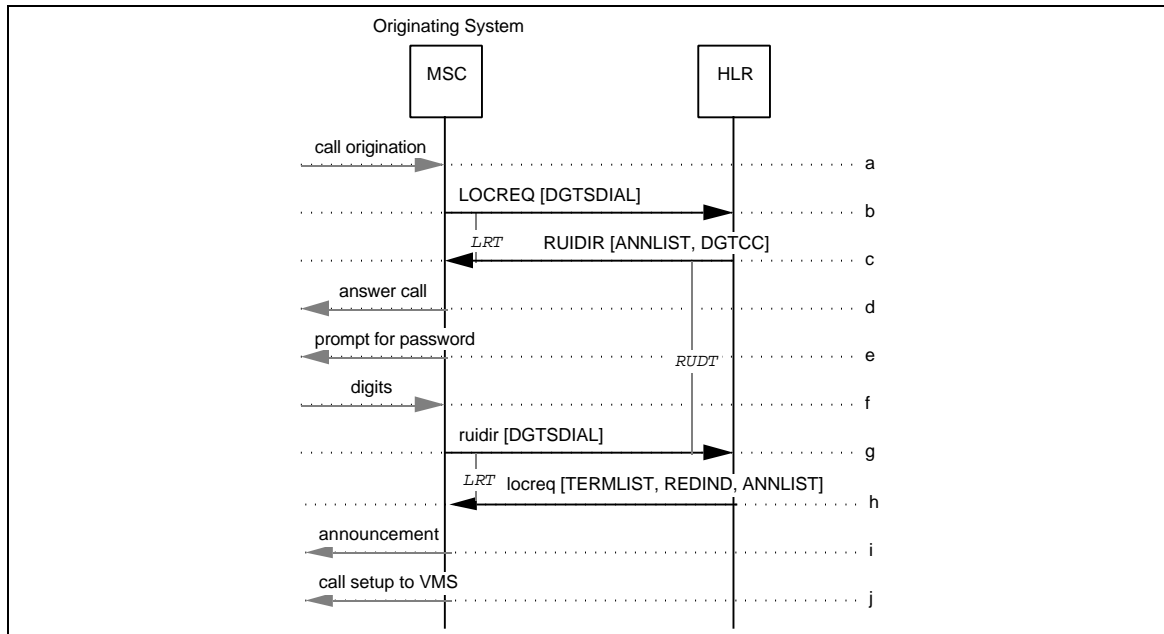

Figure 173 PCA Invocation with Call Refused to Voice Mail

- a-f. Same as PCA, Section 6.15.4, Steps a-f.
- g. The Originating MSC sends a `rui di r` to the HLR, containing the digits dialed by the user. The HLR checks the digits received against the PCA screening list for the called MS. In this scenario, the password is not matched with an entry in the list; therefore, the call is not allowed to proceed to the MS but is to be forwarded to a voice mail system (VMS).
- h. The HLR sends a `locreq` to the Originating MSC, including the VMS DN in the TerminationList parameter, along with an indication of the reason for extending the incoming call (i.e., for PCA) in the DMH_RedirectionIndicator parameter. The `locreq` may also include an AnnouncementList parameter indicating a particular announcement to be provided to the calling party.
- i. The Originating MSC provides call treatment as indicated in the `locreq`. In this case, the treatment is to, optionally, apply an announcement indicating that an incorrect password was entered.
- j. The Originating MSC routes the call to the VMS.

6.15.8 PCA Invocation with Call Refused to Forward-To Number

This scenario describes the invocation of PCA for an authorized MS, with the result being call refusal to a forward-to number.

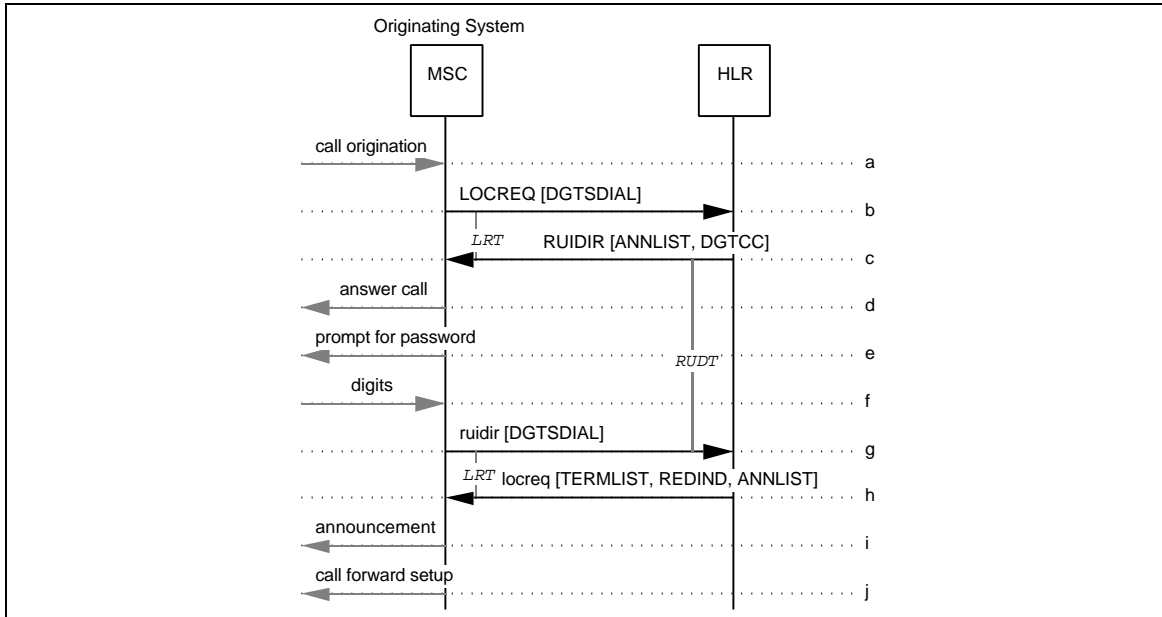

Figure 174 PCA Invocation with Call Refused to Forward-To Number

- a-f. Same as PCA, Section 6.15.4, Steps a-f.
- g. The Originating MSC sends a `rui dir` to the HLR, containing the digits dialed by the user. The HLR checks the digits received against the PCA screening list for the called MS. In this scenario, the password is not matched with an entry in the list; therefore, the call is not allowed to proceed to the MS but is to be forwarded to a DN.
- h. The HLR sends a `locreq` to the Originating MSC, including the forward-to DN in the TerminationList parameter, along with an indication of the reason for extending the incoming call (i.e., for PCA) in the DMH_RedirectionIndicator parameter. The `locreq` may also include an AnnouncementList parameter indicating a particular announcement to be provided to the calling party.
- i. The Originating MSC provides call treatment as indicated in the `locreq`. In this case, the treatment is to, optionally, apply an announcement indicating that an incorrect password was entered.
- j. The Originating MSC routes the call to the forward-to DN.

6.16 Preferred Language

This section depicts the interactions between network entities in various situations related to automatic roaming and Preferred Language (PL). These scenarios are for illustrative purposes only.

6.16.1 PL Registration (variable option)

This scenario describes the registration of PL by an MS authorized for the variable PL option.

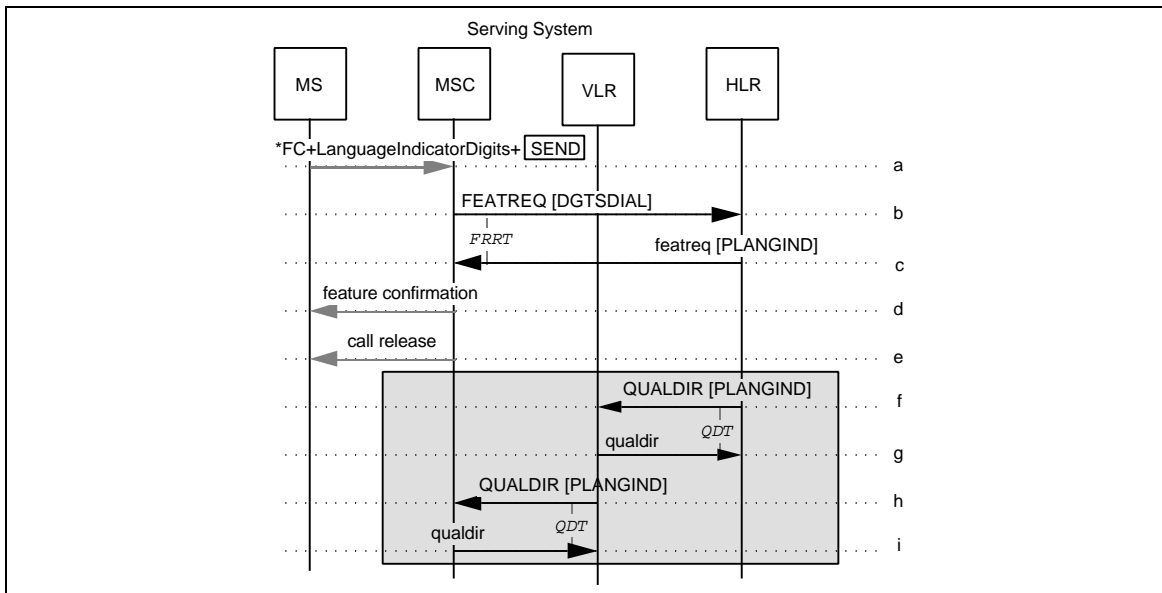

Figure 175 PL Registration (variable option)

- 1
2
3
4
5
6
7
8
9
10
11
- a. Dialed digits are received by the Serving MSC. During analysis of the dialed digits, the Serving MSC detects a feature code string.
 - b. The dialed digits are included in a FEATREQ and sent from the Serving MSC to the HLR associated with the MS.
 - c. The HLR detects the authorized Preferred Language request and sends a featreq to the Serving MSC. The featreq includes an indication of the new preferred language. The Serving MSC stores the new preferred language information.

Additional Parameters	Usage	Type
PLANGIND	Indication of new preferred language.	R

- 12
13
14
15
16
17
18
19
20
21
22
- d. The Serving MSC provides treatment to the served MS as indicated in the featreq. In this case, the treatment is to provide feature confirmation.
 - e. The Serving MSC releases the call.
 - f. The HLR reports the change in the MS's service profile by sending a QUALDI R to the VLR where the MS is registered.

Additional Parameters	Usage	Type
PLANGIND	Indication of new preferred language.	R

- 23
24
25
26
27
28
29
30
31
32
33
34
35
36
37
38
39
40
41
42
43
44
45
46
47
48
49
50
51
52
53
54
55
56
57
58
59
60
- g. The VLR sends a qual di r to the HLR.
 - h. The VLR reports the change in the MS's service profile by sending a QUALDI R to the Serving MSC.
 - i. The Serving MSC sends a qual di r to the VLR.

6.17 Priority Access and Channel Assignment

This section depicts the interactions between network entities in various situations related to automatic roaming and Priority Access and Channel Assignment (PACA). These scenarios are for illustrative purposes only.

6.17.1 Successful PACA Activation

This scenario describes the successful activation of PACA by an authorized MS.

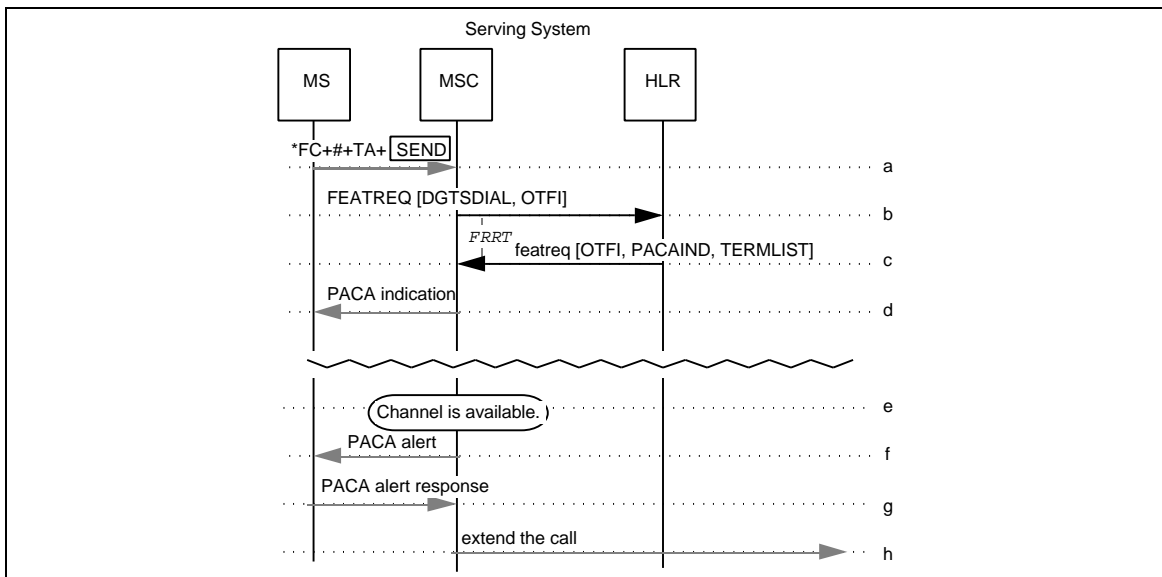

Figure 176 Successful PACA Activation

- 1
2
3
4
5
6
7
8
9
10
- a. A call origination and dialed digits are received by the Serving MSC. During analysis of the dialed digits, the Serving MSC detects a feature code string.
- b. The dialed digits are included in a FEATREQ and sent from the Serving MSC to the HLR associated with the MS. The Serving MSC also includes the OneTimeFeatureIndicator parameter if any of its status bits are set (i.e., if any special feature processing is active for the call).

Additional Parameters	Usage	Type
OTFI (Current Call)	Indicates special feature processing active for duration of call in progress.	O

- 11
12
13
14
15
16
17
18
19
20
- c. The HLR detects the authorized PACA request and sends a featreq to the Serving MSC. The featreq includes the PACA OneTimeFeatureIndicator and call routing information and the PACA indicator in the TerminationList parameter. The Serving MSC initiates PACA feature processing for the served MS using the information provided in the response.

Additional Parameters	Usage	Type
OTFI (Current Call)	Modify feature processing for duration of call in progress = Activate PACA.	R
PACA Indicator (Current Call)	Activate PACA at the indicated priority level.	R

- 21
22
23
24
25
26
27
28
29
30
31
32
33
34
35
36
37
38
39
40
41
42
43
44
45
46
47
48
49
50
51
52
53
54
55
56
57
58
59
60
- d. The Serving MSC queues the request and sends a successful PACA indication to the served MS.
- e. When a voice or traffic channel becomes available, the oldest and highest priority call request is identified. In this scenario, this corresponds to the served MS.
- f. The Serving MSC alerts the served MS using the automatic recall distinctive alerting cadence.
- g. The served MS answers the PACA alert.
- h. The Serving MSC allows the originating call to proceed and discards the PACA OneTimeFeatureIndicator.

6.17.2 Aborted PACA Activation

This scenario describes an aborted activation of PACA by an authorized MS.

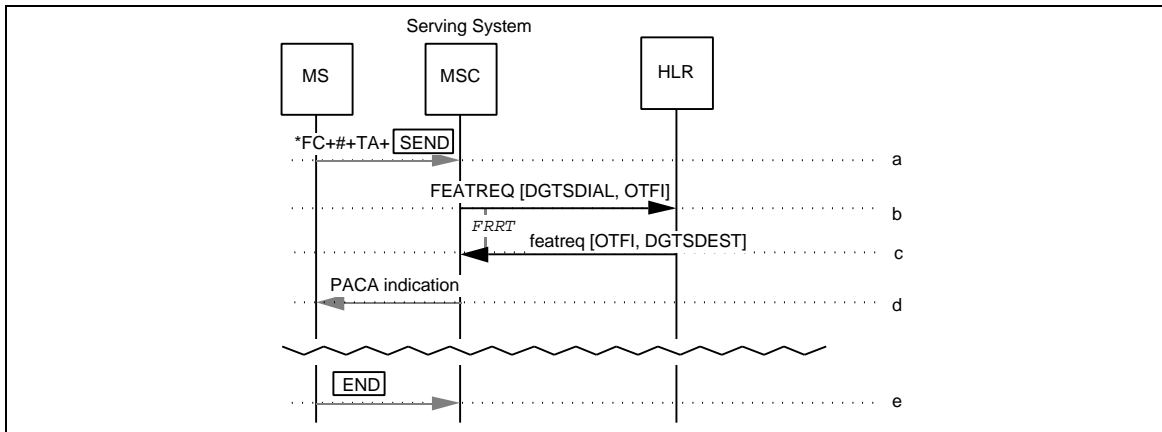

Figure 177 Aborted PACA Activation

- a-d. Same as PACA, Section 6.17.1, Steps a-d.
- e. The served MS chooses to abort the PACA call by pressing the X (END) key. At this point, the priority call request is removed from the Serving MSC's queue.

6.17.3 Unsuccessful PACA Activation

This scenario describes an unsuccessful attempt to activate PACA by an MS.

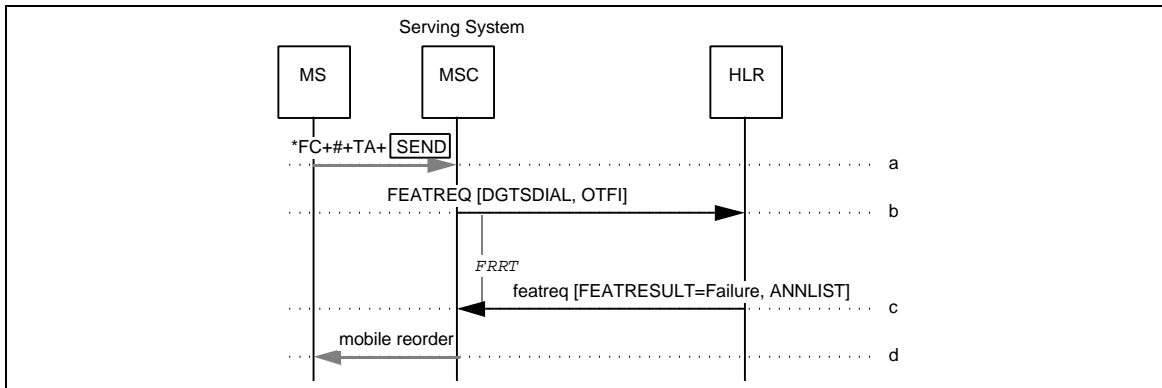

Figure 178 Unsuccessful PACA Activation with Call

- a-b. Same as PACA, Section 6.17.1, Steps a-b.
- c. The HLR sends a `featreq` to the Serving MSC, indicating an unsuccessful feature request. The `featreq` also includes the `AnnouncementList` parameter, indicating that a mobile reorder tone should be applied to the MS.
- d. Since the `featreq` indicates that an unsuccessful feature request has been made, the Serving MSC provides treatment to the served MS as indicated in the `ACTCODE` parameter. In this case, the treatment is to apply mobile reorder.

6.18 Remote Feature Control

This section depicts the interactions between network entities in various situations related to automatic roaming and Remote Feature Control (RFC). These scenarios are for illustrative purposes only.

6.18.1 Normal RFC Transaction Sequence

This scenario describes a typical RFC transaction sequence.

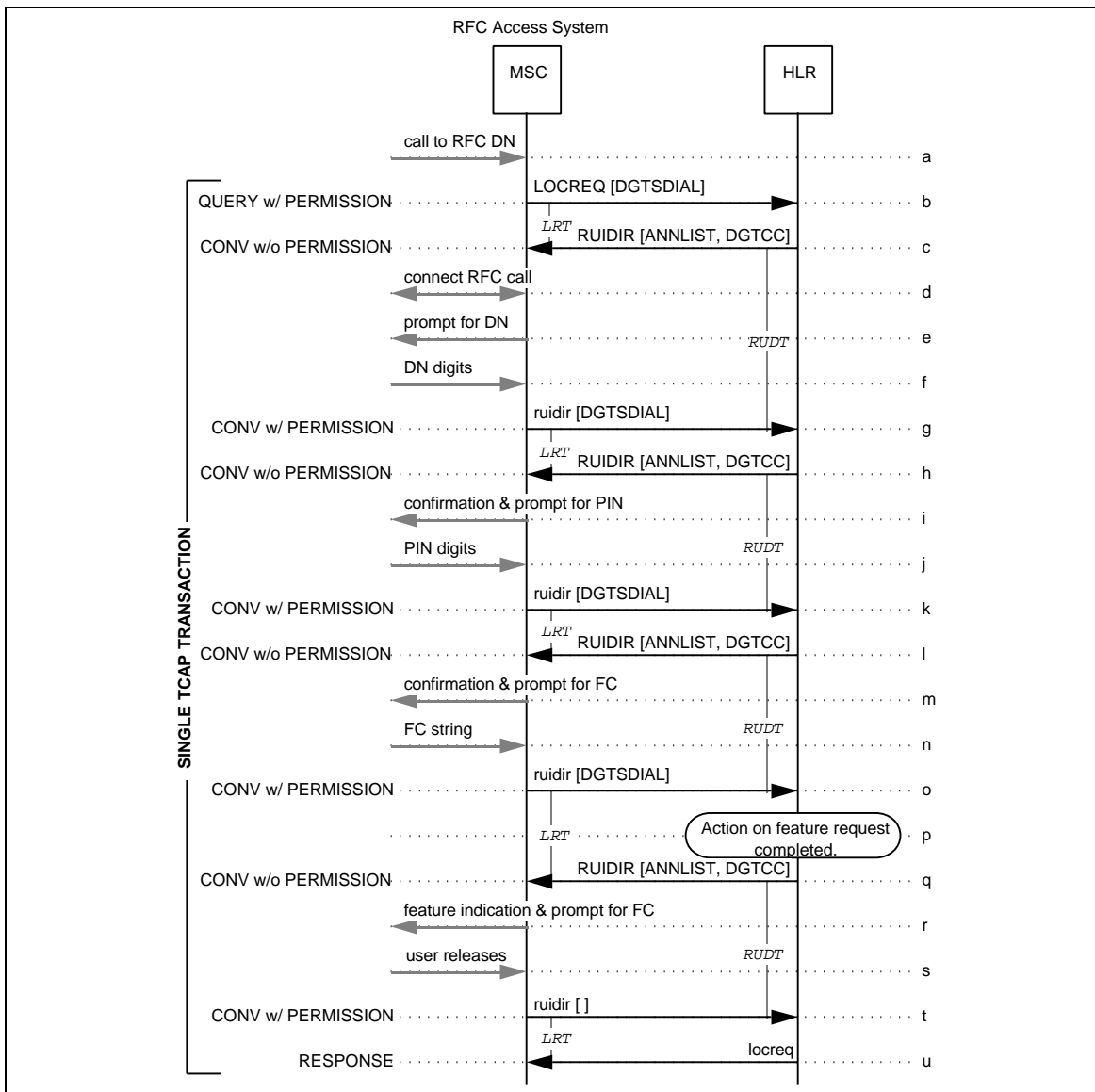

Figure 179 Typical RFC Transaction Sequence

1
2
3
4
5
6
7
8
9
10
11
12
13
14
15
16
17
18
19
20
21
22
23
24
25
26
27
28
29
30
31
32
33
34
35
36
37
38
39
40
41
42
43
44
45
46
47
48
49
50
51
52
53
54
55
56
57
58
59
60

- a. An incoming call to the RFC Access DN arrives at the RFC Access System MSC (RFC-MSC).
- b. The RFC-MSC sends a `LOCREQ` to the HLR. The HLR, on receipt of the `LOCREQ` indicating an RFC call, initiates a user interaction session.
- c. The HLR sends a `RUI DI R` to the RFC-MSC.
- d. On receipt of the `RUI DI R`, the RFC-MSC turns off the `LOCREQ` timer and provides call treatment as indicated in the received message. In this case, the treatment is to answer the call (i.e., connect the calling party to subsystem capable of user interaction).
- e. The RFC-MSC prompts the user based on the information in the received `RUI DI R` and waits for digits.
- f. The user responds with its DN digits.
- g. The RFC-MSC sends a `rui di r` to the HLR, containing the digits dialed by the user.
- h. The HLR sends a `RUI DI R` to the RFC-MSC, confirming the receipt and validation of the user's DN and prompting for the user's PIN.
- i. The RFC-MSC prompts the user based on the information in the received `RUI DI R`.
- j. The user responds with its PIN digits.
- k. The RFC-MSC sends a `rui di r` to the HLR, containing the digits dialed by the user.
- l. The HLR sends a `RUI DI R` to the RFC-MSC, confirming the receipt and validation of the user's PIN and prompting for the user's feature request.
- m. The RFC-MSC prompts the user based on the information in the received `RUI DI R`.
- n. The user responds with a feature code string.
- o. The RFC-MSC sends a `rui di r` to the HLR, containing the digits dialed by the user.
- p. The HLR completes processing of the feature request.
- q. The HLR sends a `RUI DI R` to the RFC-MSC, indicating the result of the feature request and prompting for another feature request.
- r. The RFC-MSC prompts the user based on the information in the received `RUI DI R`.
- s. The user releases the call.
- t. The RFC-MSC sends an empty `rui di r` to the HLR.
- u. The HLR terminates the user interaction session and sends a `locreq` to the RFC-
MSC.

6.19 Selective Call Acceptance

This section depicts the interactions between network entities in various situations related to automatic roaming and Selective Call Acceptance (SCA). These scenarios are for illustrative purposes only.

6.19.1 SCA Demand Activation or De-Activation

The information flows required for the demand activation or de-activation of SCA by an authorized MS are described in Section 5.5.1.

6.19.2 SCA Variable Diversion Registration

The information flows required for the registration of SCA variable diversion by an authorized MS are described in Section 5.5.1.

6.19.3 SCA Variable Number Registration or De-Registration

The information flows required for the registration or de-registration of SCA variable number by an authorized MS are described in Section 5.5.1.

6.19.4 SCA Invocation with Call Accepted

This scenario describes the invocation of SCA for an authorized MS, with the result being call acceptance.

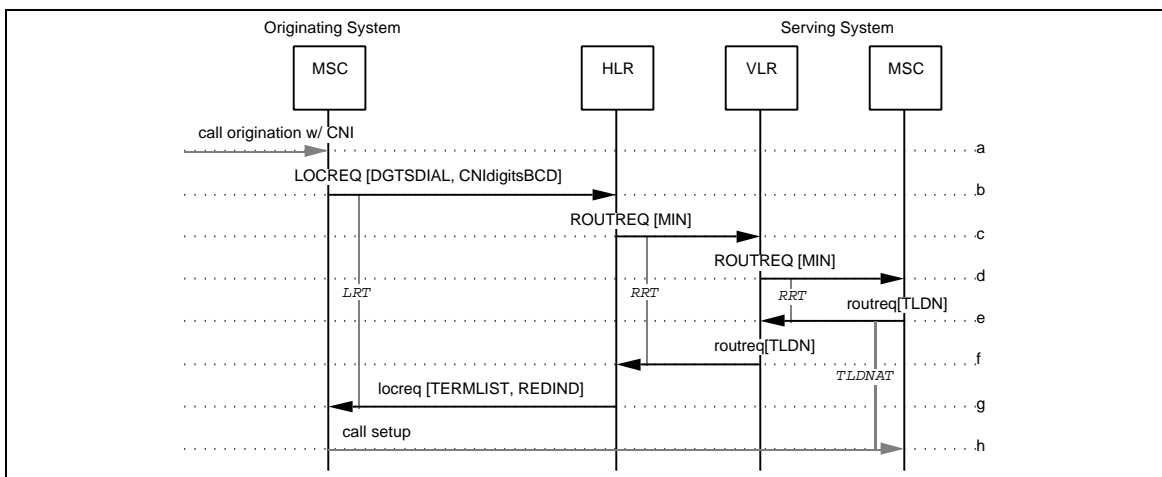

Figure 180 SCA Invocation with Call Accepted

- 1
2
3
4
5
6
7
8
9
- a. A call origination and the dialed MS address digits (i.e., directory number), as well as calling number identification (CNI) information, are received by the Originating MSC.
 - b. The Originating MSC sends a **LOCREQ** to the MS's HLR, including the CNI information. Note that, for the purposes of SCA, subaddress information is not required.

10
11
12
13
14
15
16
17
18
19

Additional Parameters	Usage	Type
CNI digitsBCD:	CNI digits parameters in BCD format:	
[CallingPartyNumber-Digits1]	Calling number digits (network-provided), incl. presentation restriction information.	R
[CallingPartyNumber-Digits2]	Calling number digits (user-provided), incl. presentation restriction information.	O
[RedirectingNumber-Digits]	Redirecting number digits, incl. presentation restriction information.	O

- 20
21
22
23
24
- c. The HLR determines from the MS's service profile that SCA is a ctive. It checks the CNI received in the **LOCREQ** against the SCA screening list for the called MS. In this scenario, the CNI is matched with an entry in the list; therefore, the call is allowed to proceed.

The HLR constructs a **ROUTREQ** and sends it to the VLR where the MS is registered.

- 25
26
27
28
29
30
31
32
33
34
35
36
37
38
39
40
41
42
43
44
45
46
47
48
49
50
51
52
53
54
55
56
57
58
59
60
- d. The VLR forwards the **ROUTREQ** to the current Serving MSC.
 - e. In reaction to the **ROUTREQ**, the Serving MSC checks its internal data structures and determines that the MS is currently idle. Therefore the Serving MSC allocates a TLDN and returns this information to the VLR in the **roureq**.
 - f. The VLR sends the **roureq** to the HLR.
 - g. When the **roureq** is received by the HLR, it returns a **locreq** to the Originating MSC. The **locreq** includes routing information in the form of the TerminationList parameter, along with an indication of the reason for extending the incoming call (i.e., for CD) in the DMH_RedirectionIndicator parameter.
 - h. A voice path is then established between the Originating MSC and the Serving MSC using protocols defined by the interconnection method.

6.19.5 SCA Invocation with Call Refused to Tone or Announcement

This scenario describes the invocation of SCA for an authorized MS, with the result being call refusal to a tone or announcement.

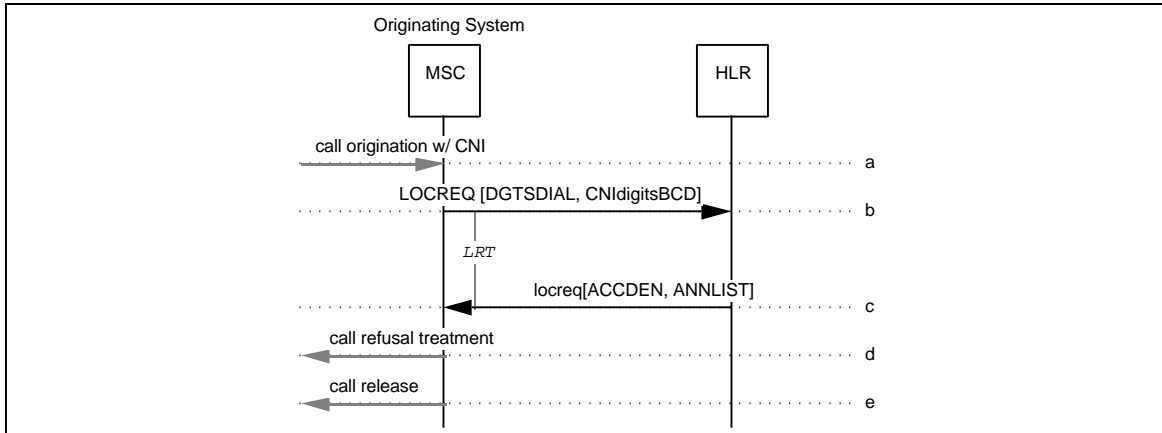

Figure 181 SCA Invocation with Call Refused to Tone or Announcement

- a-b. Same as SCA, Section 6.19.4, Steps a-b.
- c. In this scenario, the CNI is not matched with an entry in the list and SCA variable diversion is not registered; therefore, the call is given refusal treatment. The HLR returns a `locreq` to the Originating MSC including the reason for denying access. The `locreq` may also include an `AnnouncementList` parameter indicating a particular announcement to be provided to the calling party.
- d. The Originating MSC provides treatment to the served MS as indicated in the `locreq`. In this case, the treatment is to provide call refusal treatment.
- e. The Originating MSC releases the call.

6.19.6 SCA Invocation with Call Refused to Voice Mail

This scenario describes the invocation of SCA for an authorized MS, with the result being call refusal to a voice message system.

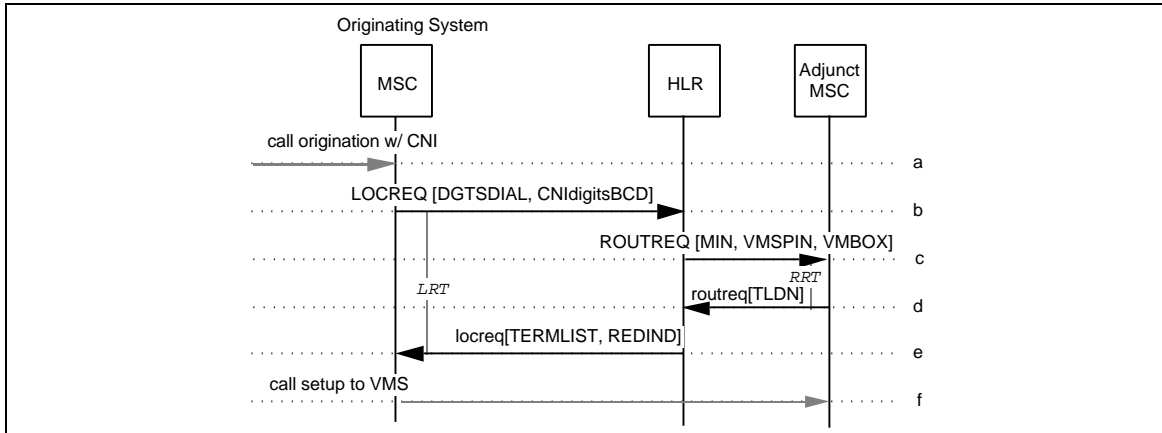

Figure 182 SCA Invocation with Call Refused to Voice Mail

- a-b. Same as SCA, Section 6.19.4, Steps a-b.
- c. In this scenario, the CNI is not matched with an entry in the list but SCA variable diversion is registered with the forward-to number that of a voice message system (VMS). The HLR sends a ROUTREQ to the Adjunct MSC.
- d. The Adjunct MSC allocates a TLDN and returns this information to the HLR in the routreq.
- e. The HLR sends a locreq to the Originating MSC, including the VMS DN in the TerminationList parameter, along with an indication of the reason for extending the incoming call (i.e., for SCA) in the DMH_RedirectionIndicator parameter. The locreq may also include an AnnouncementList parameter indicating a particular announcement to be provided to the calling party.
- f.. The Originating MSC then establishes a call to the specified forward-to number (i.e., the VMS).

6.19.7 SCA Invocation with Call Refused to Forward-To Number

This scenario describes the invocation of SCA for an authorized MS, with the result being call refusal to a forward-to number.

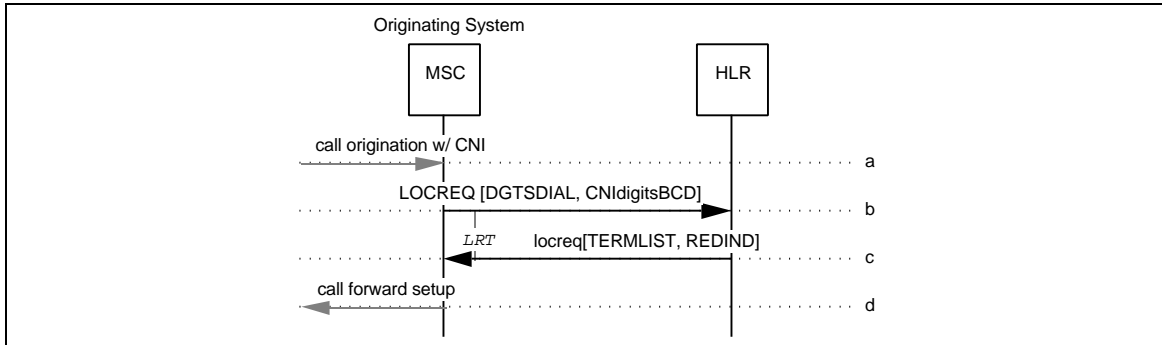

Figure 183 SCA Invocation with Call Refused to Forward-To Number

- a-b. Same as SCA, Section 6.19.4, Steps a-b.
- c. In this scenario, the CNI is not matched with an entry in the list but SCA variable diversion is registered with a forward-to number. The HLR sends a `locreq` to the Originating MSC, including the forward-to DN in the `TerminationList` parameter, along with an indication of the reason for extending the incoming call (i.e., for SCA) in the `DMH_RedirectionIndicator` parameter. The `locreq` may also include an `AnnouncementList` parameter indicating a particular announcement to be provided to the calling party.
- d. The Originating MSC then establishes a call to the specified forward-to number.

6.20 Subscriber PIN Access

This section depicts the interactions between network entities in various situations related to automatic roaming and Subscriber PIN Access (SPINA). These scenarios are for illustrative purposes only.

6.20.1 SPINA Variable Registration

This scenario describes a SPINA PIN registration change by an authorized MS.

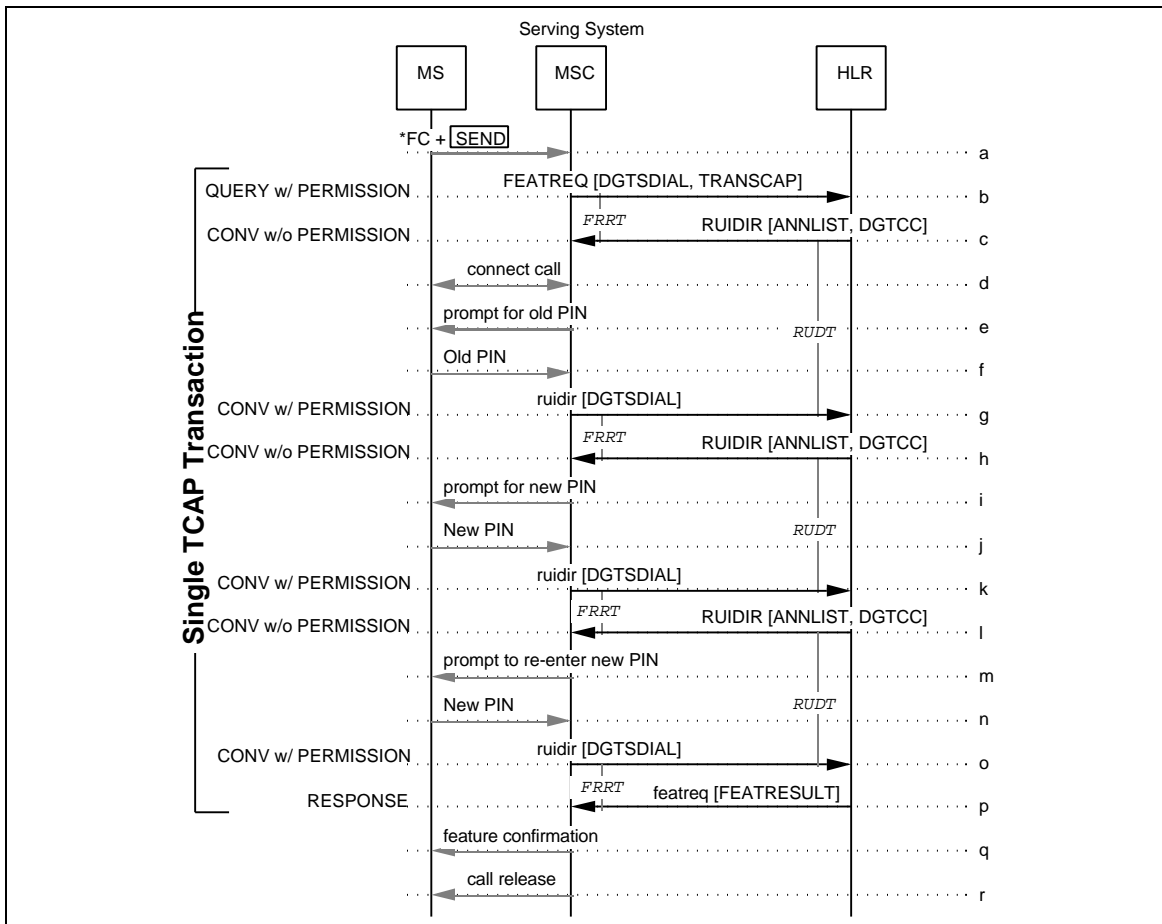

Figure 184 SPINA Variable Registration

1
2
3
4
5
6
7
8
9
10
11
12
13
14
15
16
17
18
19
20
21
22
23
24
25
26
27
28
29
30
31
32
33
34
35
36
37
38
39
40
41
42
43
44
45
46
47
48
49
50
51
52
53
54
55
56
57
58
59
60

- a. Dialed digits are received by the Serving MSC. During analysis of the dialed digits, the Serving MSC detects a feature code string.
- b. The dialed digits are included in a FEATREQ and sent from the Serving MSC to the HLR associated with the MS. The TransactionCapability parameter is also included in the FEATREQ, indicating that the Serving MSC supports receiving RUI DIRS.
- c. The HLR recognizes the SPINA registration request and sends a RUI DIR to the Serving MSC.
- d. On receipt of the RUI DIR, the Serving MSC turns off the FEATREQ timer and provides call treatment as indicated in the received message. In this case, the treatment is to answer the call (i.e., connect the calling party to subsystem capable of user interaction).
- e. The Serving MSC prompts the user based on the information in the received RUIDIR (in the DigitCollectionControl parameter) and waits for digits.
- f. The user responds with his or her old PIN.
- g. The Serving MSC sends a rui di r to the HLR, containing the digits dialed by the user, and restarts the FRRT timer.
- h. The HLR sends a RUI DIR to the Serving MSC, directing the Serving MSC (a) to prompt the calling user for its new PIN, and (b) to collect digits from user.
- i. The Serving MSC prompts the user based on the information in the received RUI DIR.
- j. The user responds with his or her new PIN digits.
- k. The Serving MSC sends a rui di r to the HLR, containing the digits dialed by the user, and restarts the FRRT timer.
- l. The HLR sends a RUI DIR to the Serving MSC, directing the Serving MSC (a) to prompt the calling user to re-enter its new PIN, and (b) to collect digits from the user.
- m. The Serving MSC prompts the user based on the information in the received RUI DIR.
- n. The user responds by re-entering its new PIN.
- o. The Serving MSC sends a rui di r to the HLR, containing the digits dialed by the user, and restarts the FRRT timer.
- p. The HLR updates the served MS's SPINA registration information and sends a featreq including the FeatureResult parameter indicating successful feature operation to the Serving MSC.
- q. The Serving MSC provides treatment to the served MS as indicated in the featreq. In this case, the treatment is to provide feature confirmation.
- r. The Serving MSC releases the call.

6.20.2 SPINA Demand Activation or De-Activation

This scenario describes the demand activation or de-activation of SPINA by an authorized MS.

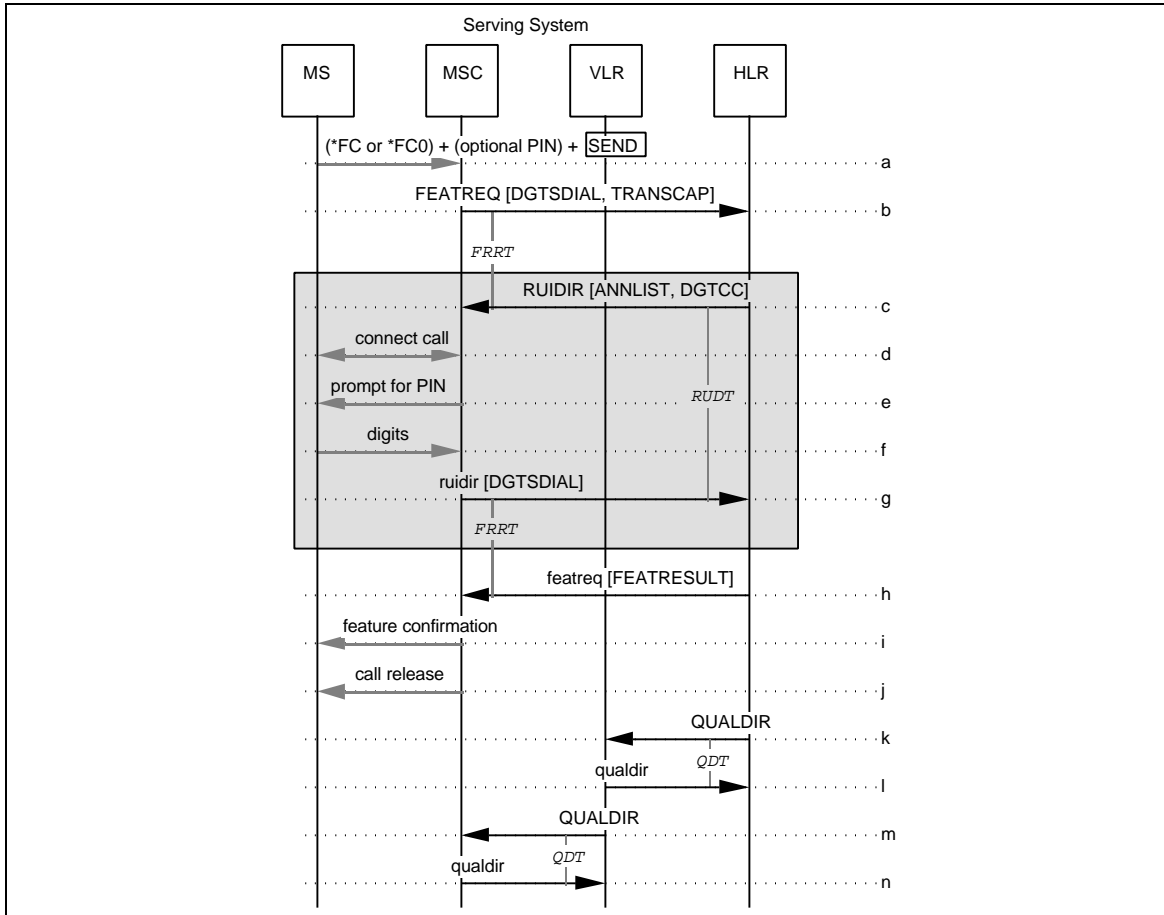

Figure 185 SPINA Demand Activation or De-Activation

1
2
3
4
5
6
7
8
9
10
11
12
13
14
15
16
17
18
19
20
21
22
23
24
25
26
27
28
29
30
31
32
33
34
35
36
37
38
39
40
41
42
43
44
45
46
47
48
49
50
51
52
53
54
55
56
57
58
59
60

- a. Dialed digits are received by the Serving MSC. During analysis of the dialed digits, the Serving MSC detects a feature code string.
- b. The dialed digits are included in a FEATREQ and sent from the Serving MSC to the HLR associated with the MS. The TransactionCapability parameter is also included in the FEATREQ, indicating that the Serving MSC supports receiving RUI DI RS.
The HLR recognizes the SPINA activation or de-activation request. If the subscriber's PIN is included in the feature code string received then go to Step h.
- c. Otherwise, the HLR sends a RUI DI R to the Serving MSC. The message directs the Serving MSC (a) to answer the call, (b) to prompt the calling user for its PIN, and (c) to collect digits from the user.
- d. On receipt of the RUI DI R, the Serving MSC turns off the FEATREQ timer and provides call treatment as indicated in the received message. In this case, the treatment is to answer the call (i.e., connect the calling party to subsystem capable of user interaction).
- e. The Serving MSC prompts the user based on the information in the received RUIDIR (in the DigitCollectionControl parameter) and waits for digits.
- f. The user responds with his or her PIN.
- g. The Serving MSC sends a rui di r to the HLR, containing the digits dialed by the user, and restarts the FRRT timer.
- h. After validating the PIN, the HLR updates the served MS's SPINA activation status and sends a featreq including the FeatureResult parameter indicating successful feature operation to the Serving MSC.
- i. The Serving MSC provides treatment to the served MS as indicated in the featreq. In this case, the treatment is to provide feature confirmation.
- j. The Serving MSC releases the call.
- k. The HLR reports the change in the MS's service profile by sending a QUALDI R, including the OriginationIndicator parameter indicating origination denied or allowed, to the VLR where the MS is registered.
- l. The VLR returns an empty qual di r to the HLR.
- m. The VLR reports the change in the MS's service profile by relaying the OriginationIndicator parameter in a QUALDI R sent to the Serving MSC.
- n. The Serving MSC returns an empty qual di r to the VLR.

6.20.3 Call Origination with SPINA Active

This scenario describes the normal operation of the SPINA feature when it is active and the served MS attempts a call origination. If SPINA is active, the previously received OriginationIndicator for the subscriber shall have indicated that originations were denied.

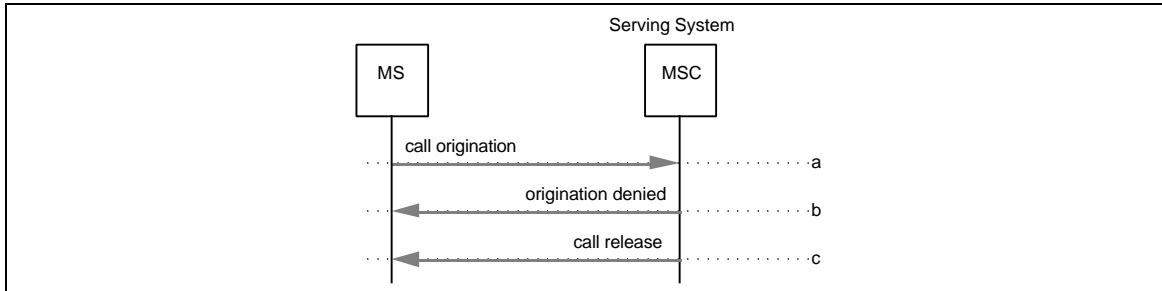

Figure 186 Call Origination with SPINA Active

- Dialed digits are received by the Serving MSC. The Serving MSC determines that this represents an call origination and that SPINA is active (i.e., the OriginationIndicator is set to deny the call).
- Therefore, the Serving MSC notifies the served MS that origination is denied.
- The Serving MSC releases the call.

6.20.4 Feature Request with SPINA Active

This scenario describes the normal operation of the SPINA feature when it is active and the served MS issues a feature request.

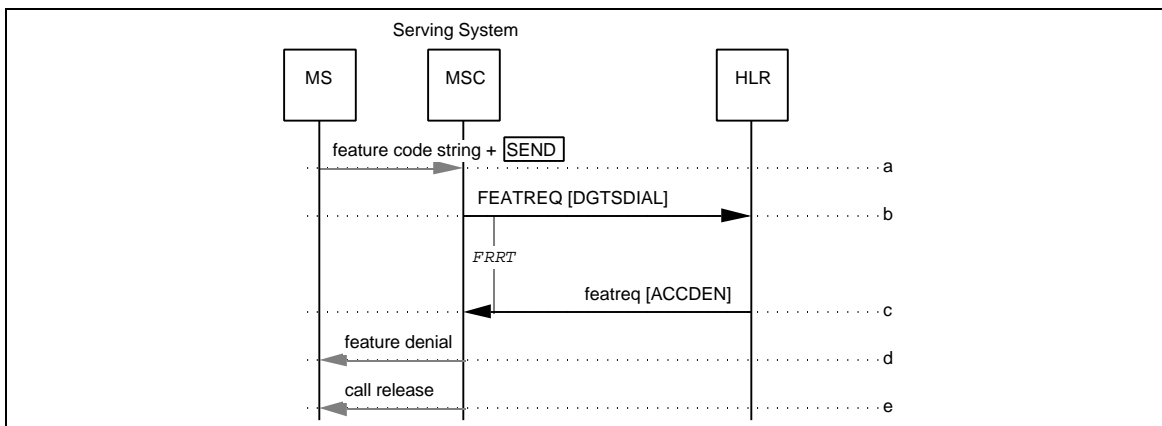

Figure 187 Feature Request with SPINA Active

- Dialed digits are received by the Serving MSC. During analysis of the dialed digits, the Serving MSC detects a feature code string.
- The dialed digits are included in a FEATREQ and sent from the Serving MSC to the HLR associated with the MS.

1
2
3
4
5
6
7
8
9
10
11
12
13
14
15
16
17
18
19
20
21
22
23
24
25
26
27
28
29
30
31
32
33
34
35
36
37
38
39
40
41
42
43
44
45
46
47
48
49
50
51
52
53
54
55
56
57
58
59
60

- c. The HLR determines that SPINA is active for the subscriber and that the feature request is not for SPINA de-activation; therefore, it sends a **featreq** to the Serving MSC including the FeatureResult parameter indicating unsuccessful feature operation and, optionally, parameters which specifically indicate the treatment the Serving MSC shall provide to the served MS.
- d. When the **featreq** is received from the HLR, the Serving MSC provides treatment to the served MS based on the information contained in the response. In this case, the treatment is to apply feature denial.
- e. The Serving MSC releases the call.

6.21 Subscriber PIN Intercept

This section depicts the interactions between network entities in various situations related to automatic roaming and Subscriber PIN Intercept (SPINI). These scenarios are for illustrative purposes only.

6.21.1 SPINI Variable Registration

This scenario describes a SPINI PIN registration change by an authorized MS.

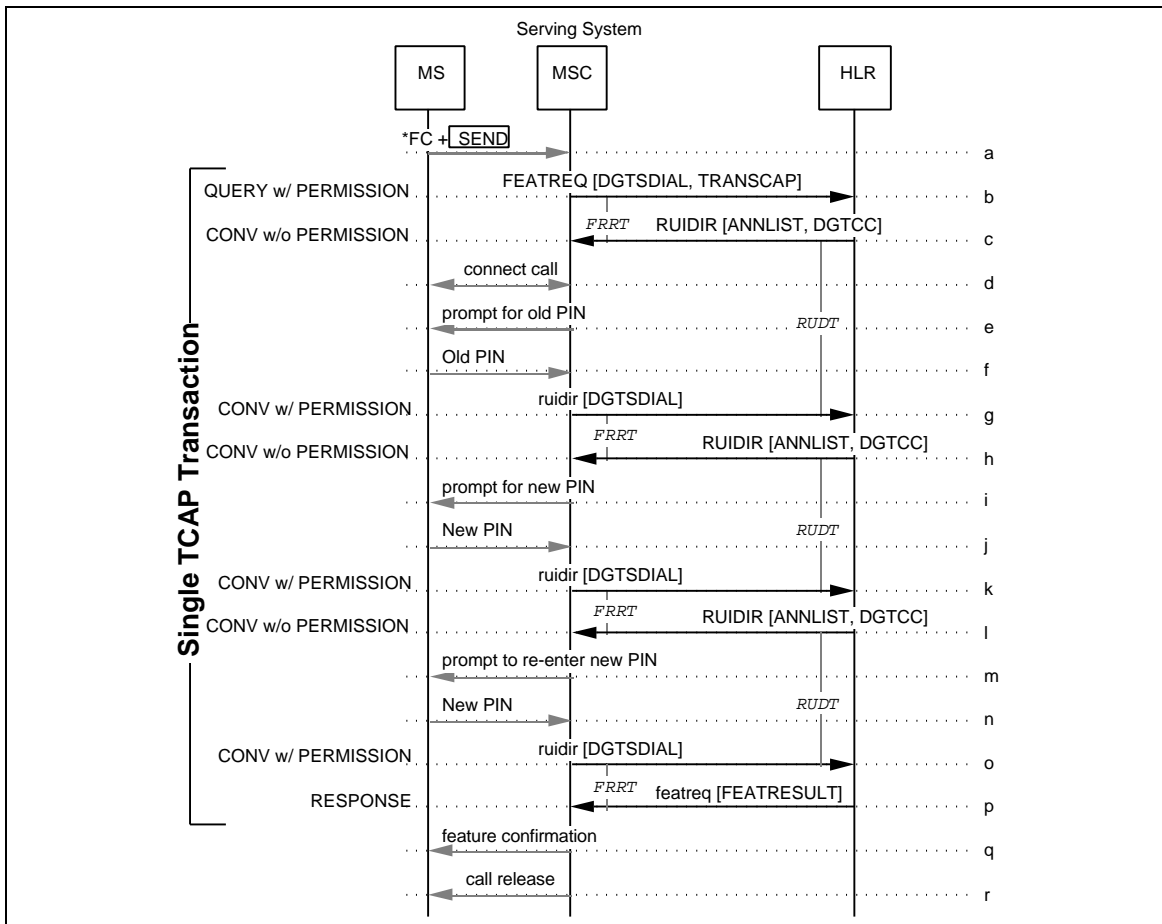

Figure 188 SPINI Variable Registration

1
2
3
4
5
6
7
8
9
10
11
12
13
14
15
16
17
18
19
20
21
22
23
24
25
26
27
28
29
30
31
32
33
34
35
36
37
38
39
40
41
42
43
44
45
46
47
48
49
50
51
52
53
54
55
56
57
58
59
60

- a. Dialed digits are received by the Serving MSC. During analysis of the dialed digits, the Serving MSC detects a feature code string.
- b. The dialed digits are included in a FEATREQ and sent from the Serving MSC to the HLR associated with the MS. The TransactionCapability parameter is also included in the FEATREQ, indicating that the Serving MSC supports receiving RUI DIRs.
- c. The HLR recognizes the SPINI registration request and sends a RUI DIR to the Serving MSC.
- d. On receipt of the RUI DIR, the Serving MSC turns off the LOCREQ timer and provides call treatment as indicated in the received message. In this case, the treatment is to answer the call (i.e., connect the calling party to subsystem capable of user interaction).
- e. The Serving MSC prompts the user based on the information in the received RUIDIR (in the DigitCollectionControl parameter) and waits for digits.
- f. The user responds with his or her old PIN.
- g. The Serving MSC sends a rui dir to the HLR, containing the digits dialed by the user, and restarts the FRRT timer.
- h. The HLR sends a RUI DIR to the Serving MSC, directing the Serving MSC (a) to prompt the calling user for his or her new PIN, and (b) to collect digits from the user.
- i. The Serving MSC prompts the user based on the information in the received RUI DIR (in the DigitCollectionControl parameter).
- j. The user responds with his or her new PIN digits.
- k. The Serving MSC sends a rui dir to the HLR, containing the digits dialed by the user, and restarts the FRRT timer.
- l. The HLR sends a RUI DIR to the Serving MSC, directing the Serving MSC (a) to prompt the calling user to re-enter his or her new PIN, and (b) to collect digits from the user.
- m. The Serving MSC prompts the user based on the information in the received RUI DIR (in the DigitCollectionControl parameter).
- n. The user responds by re-entering his or her new PIN.
- o. The Serving MSC sends a rui dir to the HLR, containing the digits dialed by the user, and restarts the FRRT timer.
- p. The HLR updates the served MS's SPINI registration information and sends a featreq including the FeatureResult parameter indicating successful feature operation to the Serving MSC. If local SPINI operation is supported, the HLR reports the change in the MS's service profile by sending a QUALDIR, including the new SPINIPIN parameter, to the VLR where the MS is registered.
- q. The Serving MSC provides treatment to the served MS as indicated in the featreq. In this case, the treatment is to provide feature confirmation.
- r. The Serving MSC releases the call.

6.21.2 Call Origination with SPINI Active and Correct PIN Entered

This scenario describes the normal operation of the SPINI feature when it is active and the served MS attempts a call origination. In this scenario, a PIN is requested and is verified.

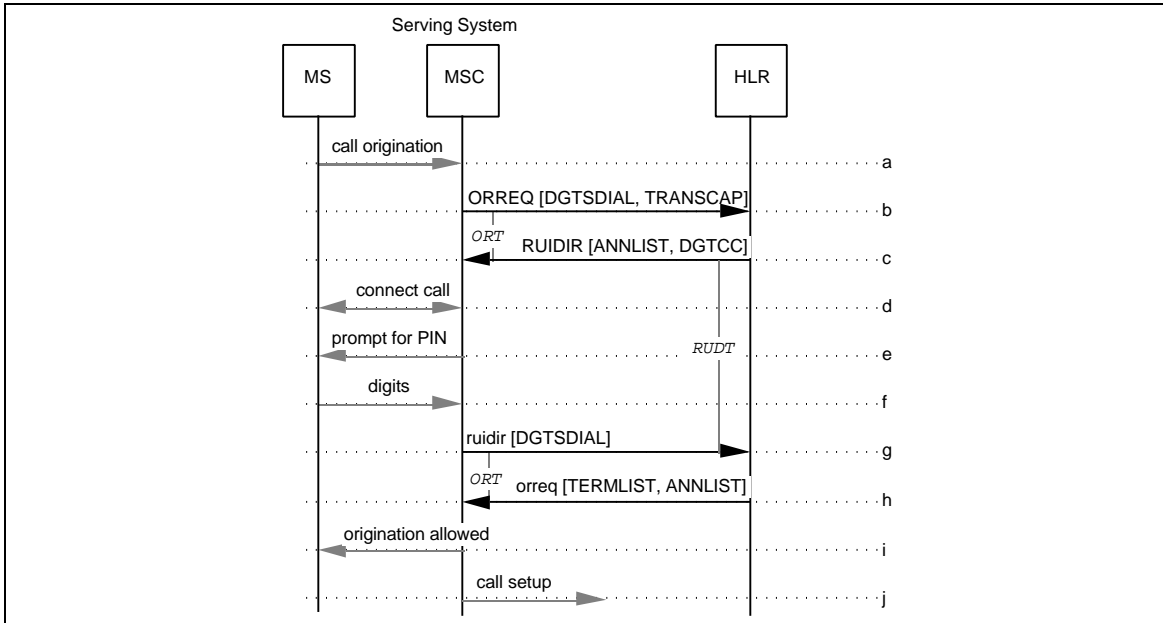

Figure 189 Call Origination with SPINI Active and Correct PIN Entered

- 1
2
3
4
5
6
7
8
9
10
11
12
13
14
15
16
- a. Dialed digits are received by the Serving MSC.
 - b. The Serving MSC determines that the call type or dialed digits matches an active trigger in the previously received OriginationTriggers parameter for the subscriber. Therefore, the dialed digits are included in an ORREQ and sent from the Serving MSC to the HLR associated with the MS. The TransactionCapability parameter is also included in the ORREQ, indicating that the Serving MSC supports receiving RUI DI Rs.
 - c. The HLR determines that the call type or dialed digits matches and that a password is required for this call; therefore, it sends a RUI DI R to the Serving MSC, directing the Serving MSC (a) to answer the call, (b) to prompt the calling user for its PIN, and (c) to collect digits from the user.

17
18
19
20
21

Parameters	Usage	Type
ANLIST	Announcement = enter PIN.	R
DGTCC	Indicates how to collect the PIN digits.	R

- 22
23
24
25
26
27
28
29
30
31
32
33
34
35
36
37
38
39
40
41
42
43
44
45
46
47
48
49
50
51
52
53
54
55
56
57
58
59
60
- d. On receipt of the RUI DI R, the Serving MSC turns off the LOCREQ timer and provides call treatment as indicated in the received message. In this case, the treatment is to answer the call (i.e., connect the calling party to subsystem capable of user interaction).
 - e. The Serving MSC prompts the user based on the information in the received RUI DI R (in the DigitCollectionControl parameter), and waits for digits.
 - f. The user responds with his or her PIN.
 - g. The Serving MSC sends a rui di r to the HLR, containing the digits dialed by the user, and restarts the ORT timer.
 - h. The HLR validates the user's PIN and returns the routing information, in the form of the TerminationList parameter, in an orreq. The orreq may also include an AnnouncementList parameter containing a SPINI confirmation announcement to be provided to the served MS.
 - i. The Serving MSC provides treatment to the served MS as indicated in the orreq. In this case, the treatment is to, optionally, provide origination confirmation.
 - j. The Serving MSC routes the call.

6.21.3 Call Origination with SPINI Active and PIN Not Required

This scenario describes the normal operation of the SPINI feature when it is active and the served MS attempts a call origination. In this scenario, a PIN is not requested.

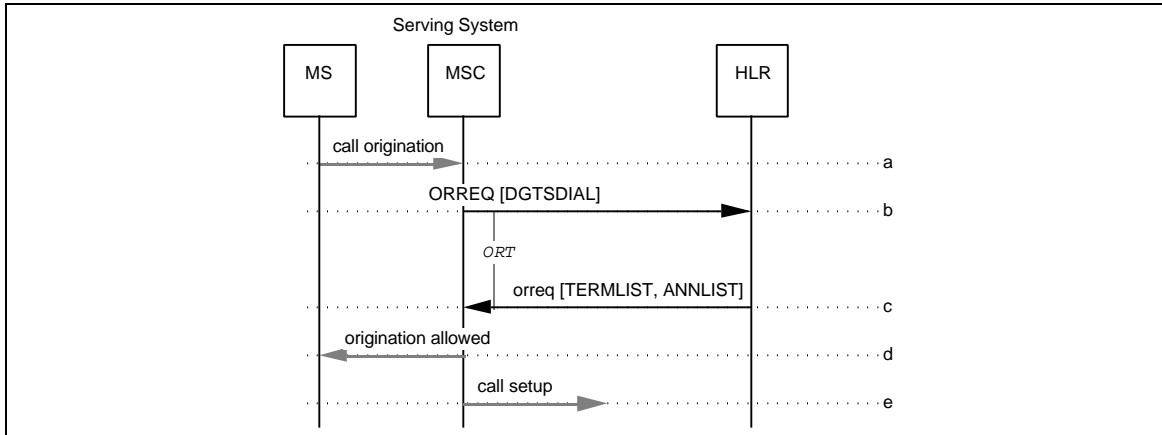

Figure 190 Call Origination with SPINI Active and PIN Not Required

- a. Dialed digits are received by the Serving MSC.
- b. The Serving MSC determines that SPINI is active. The dialed digits are included in an `ORREQ` and sent from the Serving MSC to the HLR associated with the MS.
- c. The HLR determines that SPINI is active and that a password is not required for this call; therefore, it sends routing information, in the form of the `TerminationList` parameter, in an `orreq`. The `orreq` may also include an `AnnouncementList` parameter containing a SPINI confirmation announcement to be provided to the served MS.
- d. The Serving MSC provides treatment to the served MS as indicated in the `orreq`. In this case, the treatment is to, optionally, provide origination confirmation.
- e. The Serving MSC routes the call.

6.21.4 Call Origination with SPINI Active and Incorrect PIN Entered

This scenario describes the invocation of the SPINI feature with an unsuccessful result.

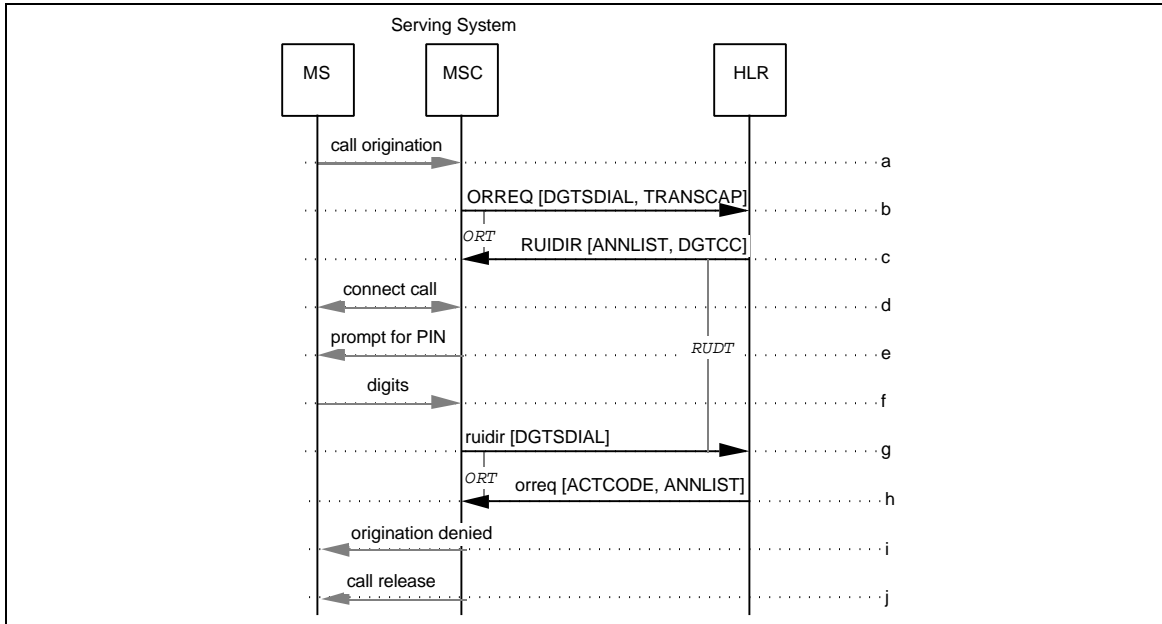

Figure 191 Call Origination with SPINI Active and Incorrect PIN Entered

- a-g. Same as SPINI, Section 6.21.2, Steps a-g.
- h. The HLR determines that the user's PIN is not valid. The HLR returns an `orreq` to the Serving MSC which includes an `ActionCode` parameter specifying that the call be released and, optionally, an `AnnouncementList` parameter, containing an announcement to be provided to the calling party.
- i. The Serving MSC provides treatment to the served MS as indicated in the `orreq`. In this case, the treatment is to provide origination denial.
- j. The Serving MSC releases the call.

6.21.5 Successful Call Origination with Local SPINI Operation

This scenario describes the normal operation of the SPINI feature when (a) the Serving MSC supports local SPINI operation, (b) SPINI is active, and (c) the served MS attempts a call origination. In this case, the correct PIN is entered.

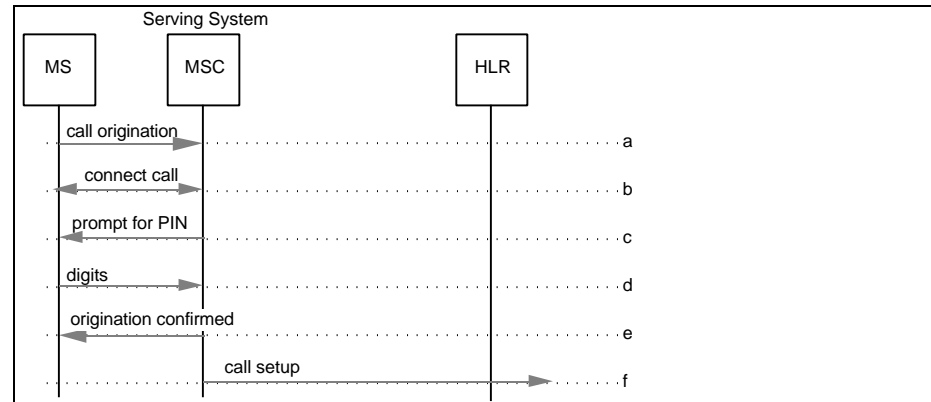

Figure 192 Successful Call Origination with Local SPINI Operation

- a. Dialed digits are received by the Serving MSC.
- b. The Serving MSC determines that local SPINI is active based on the SPINI trigger and it supports local SPINI operation (i.e., PIN is shared with the Serving System). If the call satisfies the call type criteria (i.e., PIN required on this type of call), the serving MSC answers the call. Otherwise, skip to f.
- c. The calling user is prompted for the PIN.
- d. The user responds with the PIN digits.
- e. The serving MSC validates the user's PIN and may, optionally, provide origination confirmation (e.g., announcement).
- f. The Serving MSC routes the call.

6.21.6 Unsuccessful Call Origination with Local SPINI Operation

This scenario describes the invocation of the SPINI feature when the serving MSC supports local SPINI operation, but the call origination attempt is unsuccessful. In this case, an incorrect PIN is entered.

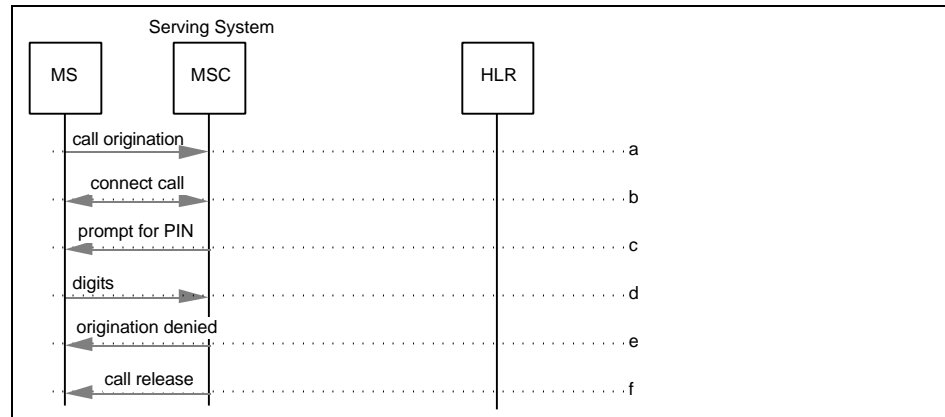

Figure 193 Unsuccessful Call Origination with Local SPINI Operation

- a. Dialed digits are received by the Serving MSC.
- b. The Serving MSC determines that local SPINI is active based on the SPINI trigger and it supports local SPINI operation. If the call satisfies the call type criteria (i.e., PIN is required on this type of call), the serving MSC answers the call. (Otherwise, the serving MSC routes the call).
- c. The calling user is prompted for the PIN.
- d. The user responds with the PIN digits.
- e. The Serving MSC determines that the user's PIN is not valid and may, optionally, provide origination denial (e.g., announcement).
- f. The Serving MSC releases the call.

6.22 Three-Way Calling

No feature-specific intersystem operations are required for the Three-Way Calling feature.

6.23 Voice Message Retrieval

This section depicts the interactions between network entities in various situations related to automatic roaming and Voice Message Retrieval (VMR). These scenarios are for illustrative purposes only.

6.23.1 Normal Operation: Invocation via Feature Code

This scenario describes the invocation of the VMR feature via the entry of a feature code string by the served MS.

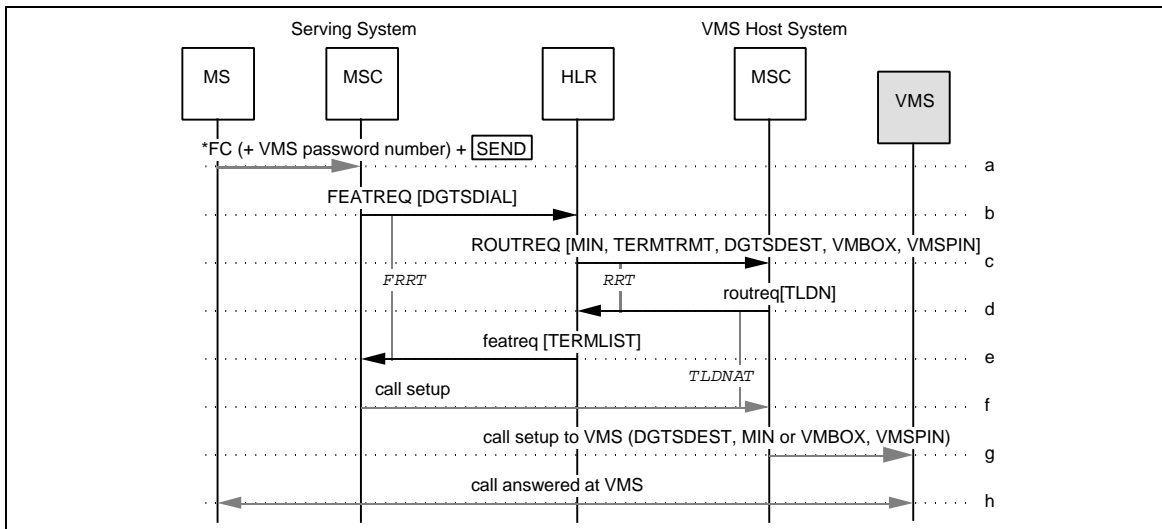

Figure 194 Normal Operation: Invocation via Feature Code

- 1
2
3
4
5
6
7
8
9
10
11
12
- a. Dialed digits are received by the Serving MSC. During analysis of the dialed digits, the Serving MSC detects a feature code string.
 - b. The dialed digits are included in a FEATREQ and sent from the Serving MSC to the HLR associated with the MS.
 - c. Based on its internal data, the HLR identifies the system which controls the VMS on which the served MS is enrolled (i.e., the VMS Host System). The HLR sends a ROUTREQ to this system's MSC (i.e., the VMS-MSC), including an indication that this request is for VMR purposes.

13
14
15
16
17
18
19
20
21
22

Additional Parameters	Usage	Type
TERMTRMT	Reason for RoutingRequest operation = VMR.	R
DGTSDEST	VMS identification number.	R
MIN	Mobile Identification Number.	R
VMBOX	Served MS's voice mailbox number, if not the MIN.	O
VMSPIN	Served MS's VMS PIN.	O

- 23
24
25
26
27
28
29
30
31
32
33
34
35
36
37
38
39
40
41
42
43
44
45
46
47
48
49
50
51
52
53
54
55
56
57
58
59
60
- d. The VMS-MSC associates the information received with a TLDN and returns this to the HLR in a routreq.
 - e. The HLR relays the TLDN to the Serving MSC via the TerminationList parameter in a featreq.
 - f. The Serving MSC provides treatment to the served MS as indicated in the featreq. In this case, the treatment is to route the call based on the TLDN information.
 - g. The VMS-MSC sets up a call to the VMS.
 - h. When the VMS answers, it is connected to the served MS.

6.23.2 Normal Operation: Invocation via Revertive Call

This scenario describes the invocation of the VMR feature via entry by the served MS of its own MIN (i.e., a revertive call).

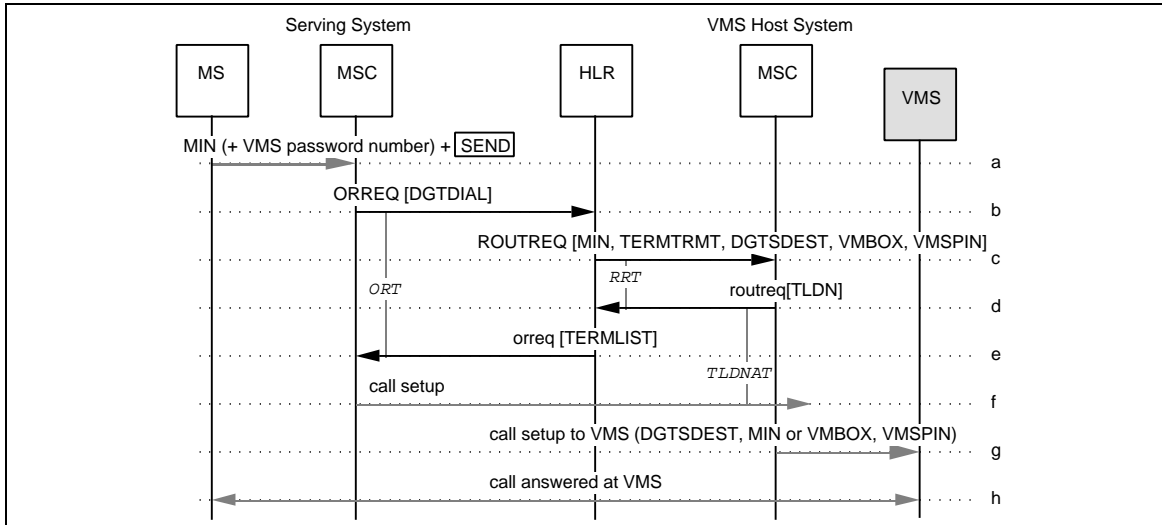

Figure 195 Normal Operation: Invocation via Revertive Call

- a. Dialed digits are received by the Serving MSC. The Serving MSC detects that the dialed digits correspond to the served MS's MIN.
- b. The dialed digits are included in a **ORREQ** and sent from the Serving MSC to the HLR associated with the MS.
- c-d. Same as VMR, Section 6.23.1, Steps c-d.
- e. The HLR relays the TLDN to the Serving MSC via the TerminationList parameter in a **orreq**.
- f-h. Same as VMR, Section 6.23.1, Steps f-h.

6.24 Voice Privacy

This section depicts the interactions between network entities in various situations related to automatic roaming and Voice Privacy (VP). These scenarios are for illustrative purposes only.

6.24.1 VP Profile Change

This scenario describes a change in the VP profile.

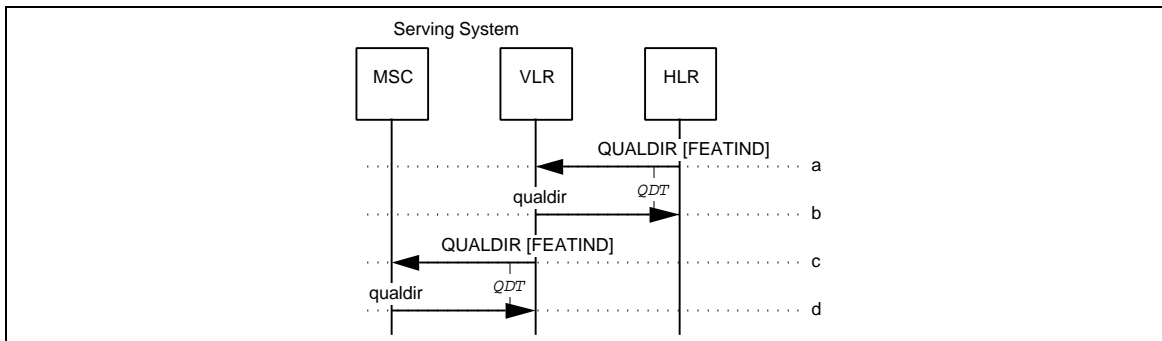

Figure 196 VP Profile Change

- a. The HLR reports the change in the MS's VP service profile by sending a `QUALDIR` to the VLR where the MS is registered.
- b. The VLR sends a `qualdir` to the HLR.
- c. The VLR reports the change in the MS's VP service profile by sending a `QUALDIR` to the Serving MSC.
- d. The Serving MSC sends a `qualdir` to the VLR.

7 SHORT MESSAGE SERVICE SCENARIOS

This section depicts the interactions between network entities in the situations related to short message service support under automatic roaming conditions.

The following abbreviations, which are in addition to those described in Section 3.1, are used in this section:

SMD-REQUEST	An implementation dependent air interface message for a short message delivery request.
SMD-ACK	An implementation dependent air interface message for a short message delivery positive acknowledgment.
SMD-NAK	An implementation dependent air interface message for a short message delivery negative acknowledgment.
{A}	The address of SME A.
{A⇒A's MC}	The address of SME A implying the address of SME A's home MC.
{A's MSC}	The address of the MSC serving MS-based SME A.
{B}	The address of SME B.
{B⇒B's MC}	The address of SME B implying the address of SME B's home MC.
{B's MSC}	The address of the MSC serving MS-based SME B.
ACK	([ACK]) Absence of cause code.
NACK	([NACK=cause code]) Presence of a cause code.
smsdpf	The SMS Delivery Pending Flag.

7.1 Successful Short Message to a Known MS-Based SME

This scenario describes the successful delivery of a short message to an active MS-based SME via its MC (terminating SMS supplementary services are possible).

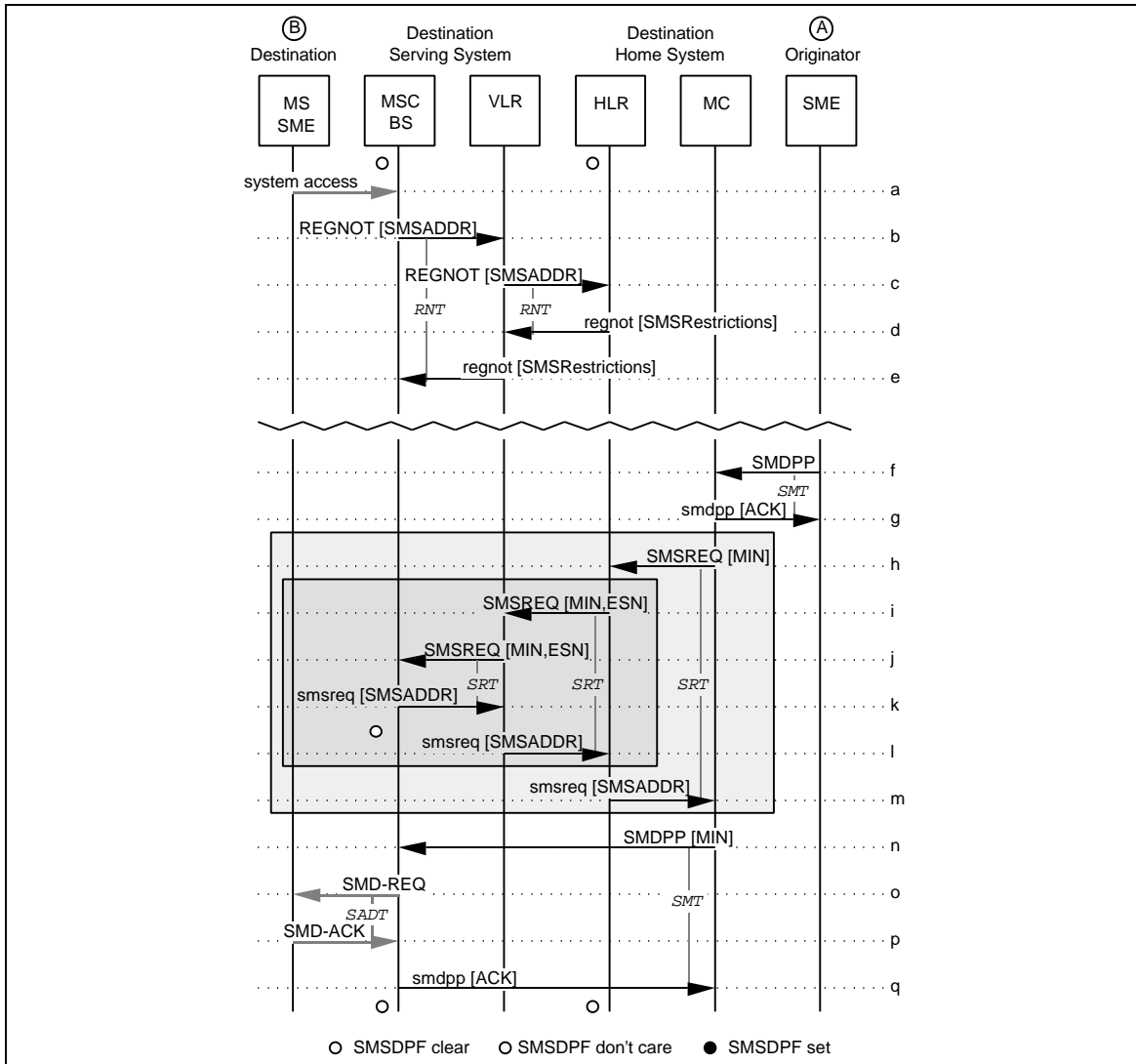

Figure 197 Successful Short Message from a Fixed SME to a Known MS-Based SME

1
2
3
4
5
6
7
8
9
10
11
12
13
14
15
16
17
18
19
20
21
22
23
24
25
26
27
28
29
30
31
32
33
34
35
36
37
38
39
40
41
42
43
44
45
46
47
48
49
50
51
52
53
54
55
56
57
58
59
60

1
2
3 a. A MS supporting a SME becomes known to a MSC through registration or other
4 system access.

5
6 b. The MSC sends a **REGNOT** message to notify the VLR of the location of an MS.

Additional Parameters	Usage	Type
SMSADDR	Address of the serving system to be used for the delivery of short messages.	O

7
8
9
10
11
12 c. The VLR forwards the **REGNOT** message to the MS's HLR. Same parameters as in
13 Step-b.

14
15 d. The HLR records the SMS delivery address for the MS and responds with a **regnot**
16 message to the VLR containing subscriber profile information.

Additional Parameters	Usage	Type
SMSRestrictions:	SMS origination and termination restrictions for MS:	
SMS_Termination-Restrictions	Indicates that the MS is allowed to receive SMS termination messages (other than "no charge" messages). Include if profile was requested and the MS is SMS capable.	O
SMS_Origination-Restrictions	Indicates that the MS is allowed to originate SMS messages. Include if profile was requested and the MS is SMS capable.	O

17
18
19
20
21
22
23
24
25
26
27
28
29 e. The VLR forwards the **regnot** message to the Serving MSC. Same parameters as
30 in Step-d.

31
32 f. The MC receives and accepts an **SMDPP** requesting delivery of an SMS message to an
33 MS-based SME

Parameters	Usage	Type
SMS_BearerData	Any desired message.	R
SMS_OriginalDestination-Address	Network address of the destination SME; i.e., {B⇒B's MC}.	R
SMS_OriginalOriginating-Address	Network address of the originating SME; i.e., {A}.	R
SMS_TeleserviceIdentifier	Identification of the teleservice; used for interpreting the bearer data.	R

34
35
36
37
38
39
40
41
42
43
44
45 g. Éand responds with an **smdpp** positive acknowledgment (which may include an
46 SMS_BearerData parameter if there is bearer data to return).

47
48 h. Steps h-m are executed because the MC does not have a current, temporary SMS
49 routing address and status for the addressed MS-based SME. The MC sends an
50 SMSREQ to the HLR serving the MS, containing the addressed SME.

51
52 i. Steps i-l are executed if the HLR does not have a current temporary SMS routing
53 address and status for the addressed MS-based SME. The HLR forwards the SMSREQ
54 to the VLR serving the MS, containing the addressed SME.

55
56 j. The VLR forwards the SMSREQ to the MSC serving the MS, containing the addressed
57 SME.
58
59
60

- 1
2
3 k. The MSC responds with an **smsreq** containing the temporary SMS routing address
4 for the served MS.

Parameters	Usage	Type
SMSADDR	Temporary address that can be used to route SMS messages. This address may be MSC-, or MS-specific.	R

- 5
6
7
8
9
10
11 l. The VLR forwards the **smsreq** toward the HLR. Same parameters as in Step-k.
12
13 m. The HLR responds with an **smsreq** toward the MC. Same parameters as in Step-k.
14
15 n. The destination MC forwards the **SMDPP** toward the destination SME using the
16 temporary SMS routing address for the MS-based SME.

Parameters	Usage	Type
MIN	Mobile Identification Number.	R
SMS_OriginalDestination-Address	Network address of the destination SME; i.e., {B}.	R
SMS_OriginalOriginating-Address	Network address of the originating SME; i.e., {A}.	R
SMS_TeleserviceIdentifier	Number of the teleservice for interpreting the SMS_BearerData.	R
SMS_BearerData	Any desired message as modified per terminating supplementary services.	R

- 17
18
19
20
21
22
23
24
25
26
27
28
29
30 o. The MSC, BS, or both forward the **SMD-REQUEST** toward the destination SME
31 using the air interface address of the MS-based SME (usually B's MIN).
32
33 p. The destination SME responds with an automatic acknowledgment (**SMD-ACK**) to
34 signal the acceptance of the **SMD-REQUEST**. The acknowledgment may include the
35 **SMS_BearerData** parameter if there is data to return.
36
37 q. The MSC translates the **SMD-ACK** into an **smdpp** positive acknowledgment and
38 returns it to the source of the corresponding **SMDPP**. The **smdpp** may include an
39 **SMS_BearerData** parameter if bearer data was provided in Step-p.
40
41
42
43
44
45
46
47
48
49
50
51
52
53
54
55
56
57
58
59
60

7.2 Short Message to a Denied MS-Based SME without Current Address

This scenario describes an SMSREQ operation to an MS-based SME whose address is not current and short message delivery is denied.

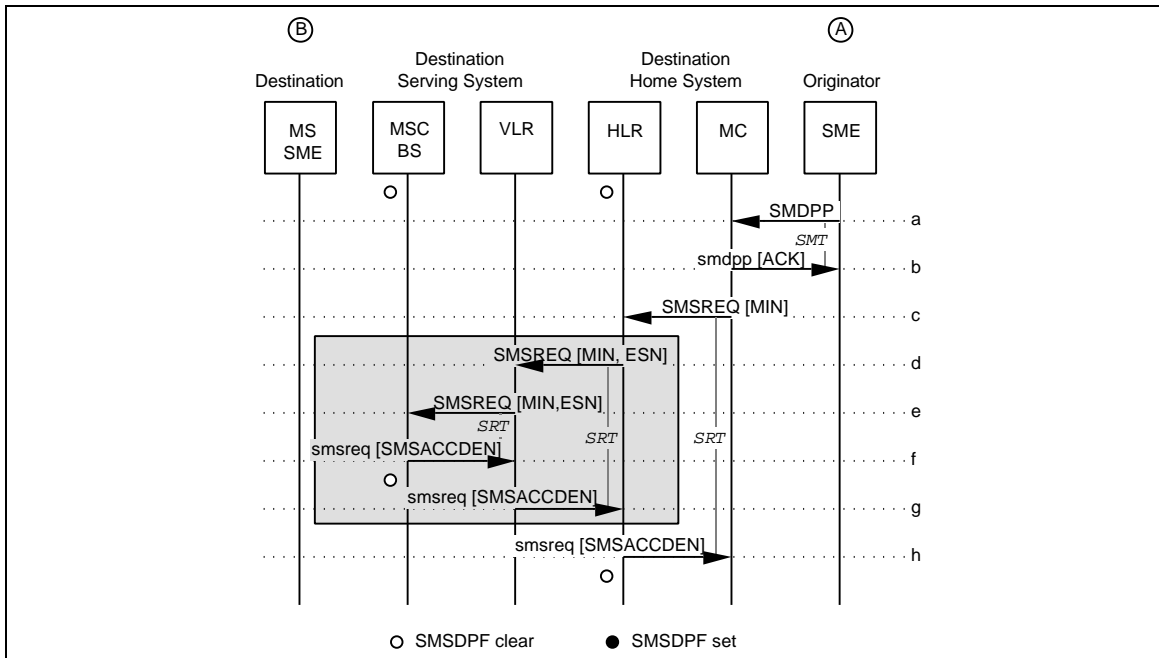

Figure 198 Short Message from a Fixed SME to a Denied MS-Based SME without Current Address

- The MC receives and accepts an SMDPP requesting delivery of an SMS message to an MS-based SME. Include the same parameters as 7.1(f).
- and responds with an `smdpp` positive acknowledgment (which may include an `SMS_BearerData` parameter if there is bearer data to return).
- Steps c-h are executed because the MC does not have a current, temporary SMS routing address and status for the addressed MS-based SME. The MC sends an SMSREQ to the HLR serving the MS, containing the addressed SME.
- Steps d-g are executed if the HLR does not have a current temporary SMS routing address and status for the addressed MS-based SME. The HLR forwards the SMSREQ to the VLR serving the MS, containing the addressed SME. Include the same parameters as Step-c with the addition of ESN.
- The VLR forwards the SMSREQ to the MSC serving the MS, containing the addressed SME. Same parameters as in Step-d.
- The request for Short Message Service is denied. The MS may be unavailable for short message delivery and no notification was requested. Notification may have been requested but the MS may be denied for other reasons. The MSC responds with an

smsreq with an indication to this effect. There is no effect to the *SMS Delivery Pending Flag*.

Parameters	Usage	Type
SMSACCDEN	Reason why messages cannot be delivered to the MS.	R

- g. The VLR forwards the smsreq toward the HLR.
- h. The HLR responds with an smsreq toward the MC.

7.3 Short Message Time-Out to an MS-Based SME without Notification

This scenario describes an unsuccessful short message delivery attempt to an MS-based SME. No notification had been requested; the MSC does not set the *SMS Delivery Pending Flag*.

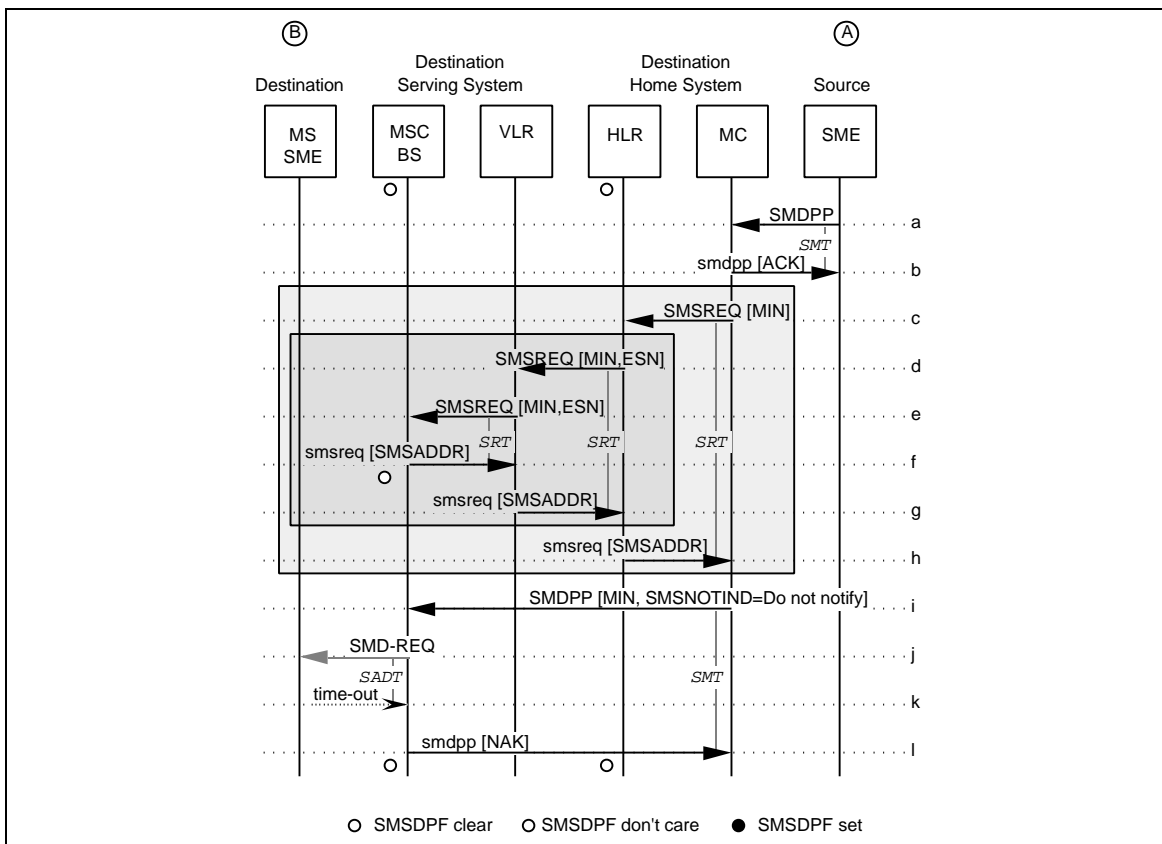

Figure 199 Short Message Time-Out to an MS-Based SME without Notification

- a-j. Same as Section 7.1, Steps f-o, respectively, except the message is discarded at Step-i because notification is not required.

- k. The SADT timer for the air interface SMD-ACK message expires (or some other problem is detected, such as a power-down de-registration or intersystem handoff)
- l. The serving MSC formulates a negative acknowledgment *smdpp* message and sends it toward the requesting entity. Since no notification was requested, there is no change to the *SMS Delivery Pending Flag*.

Parameters	Usage	Type
NAK: [SMS_CauseCode]	Negative acknowledgment signal: Indicates the reason for not delivering the SMS message.	R

7.4 Short Message Time-Out to an MS-Based SME with Notification

This scenario describes an unsuccessful short message delivery attempt to an MS-based SME. Notification had been requested; the MSC sets its *SMS Delivery Pending Flag*.

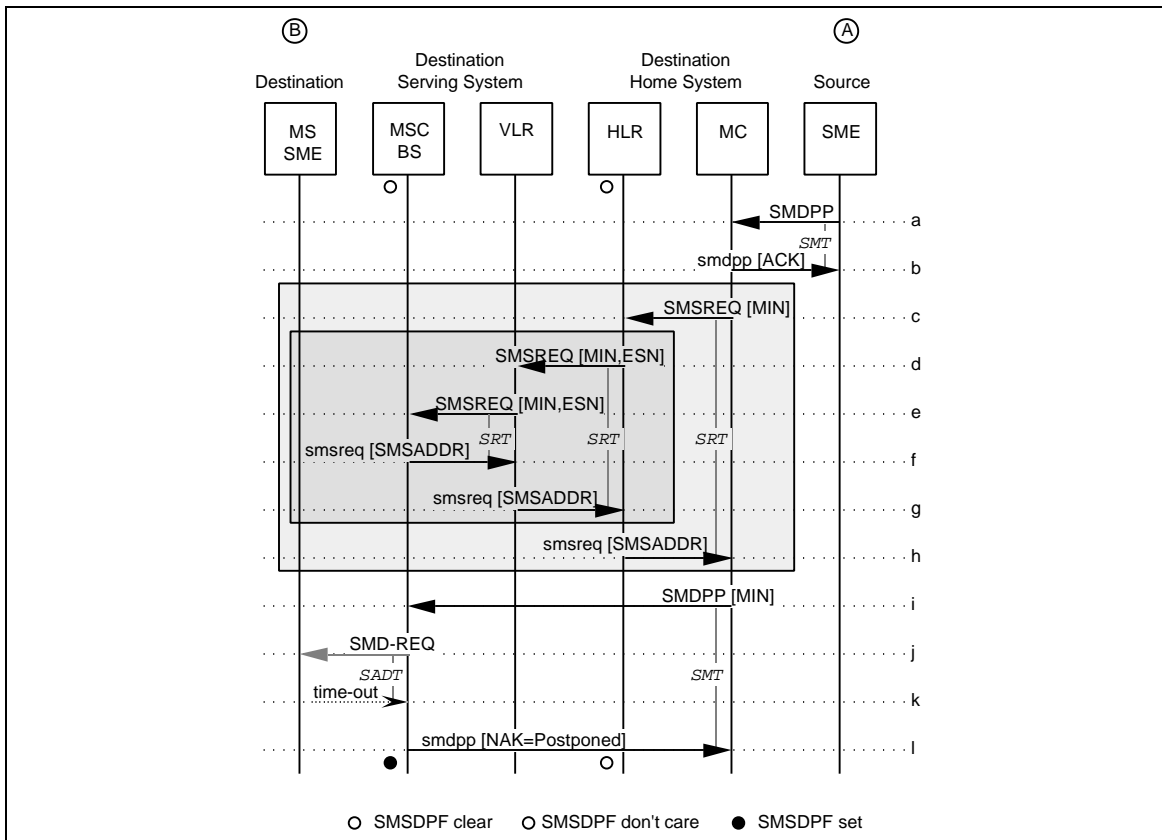

Figure 200 Short Message Time-Out to an MS-Based SME with Notification

- 1
2
3
4
5
6
7
8
9
10
11
- a-j. Same as Section 7.1, Steps f-o, respectively.
 - k. The SADT timer for the air interface **SMD-ACK** message expires (or some other problem is detected, such as a power-down de-registration or intersystem handoff)
 - l. Since notification was requested, the serving MSC formulates a negative acknowledgment **smdpp** message indicating postponed delivery and sends it toward the requesting entity. The MSC sets its *SMS Delivery Pending Flag*.

12
13
14
15
16
17

Parameters	Usage	Type
NAK: [SMS_CauseCode]	Negative acknowledgment signal: Indicates the reason for not delivering the SMS message.	R

18
19
20
21
22
23
24
25
26
27
28
29
30
31
32
33
34
35
36
37
38
39
40
41
42
43
44
45
46
47
48
49
50
51
52
53
54
55
56
57
58
59
60

The MC should wait for notification.

7.5 Short Message with Originating SMS Supplementary Services to an MS-Based SME

This scenario describes a successful short message delivery to an MS-based SME via the originating SME's MC, invoking originating SMS supplementary services.

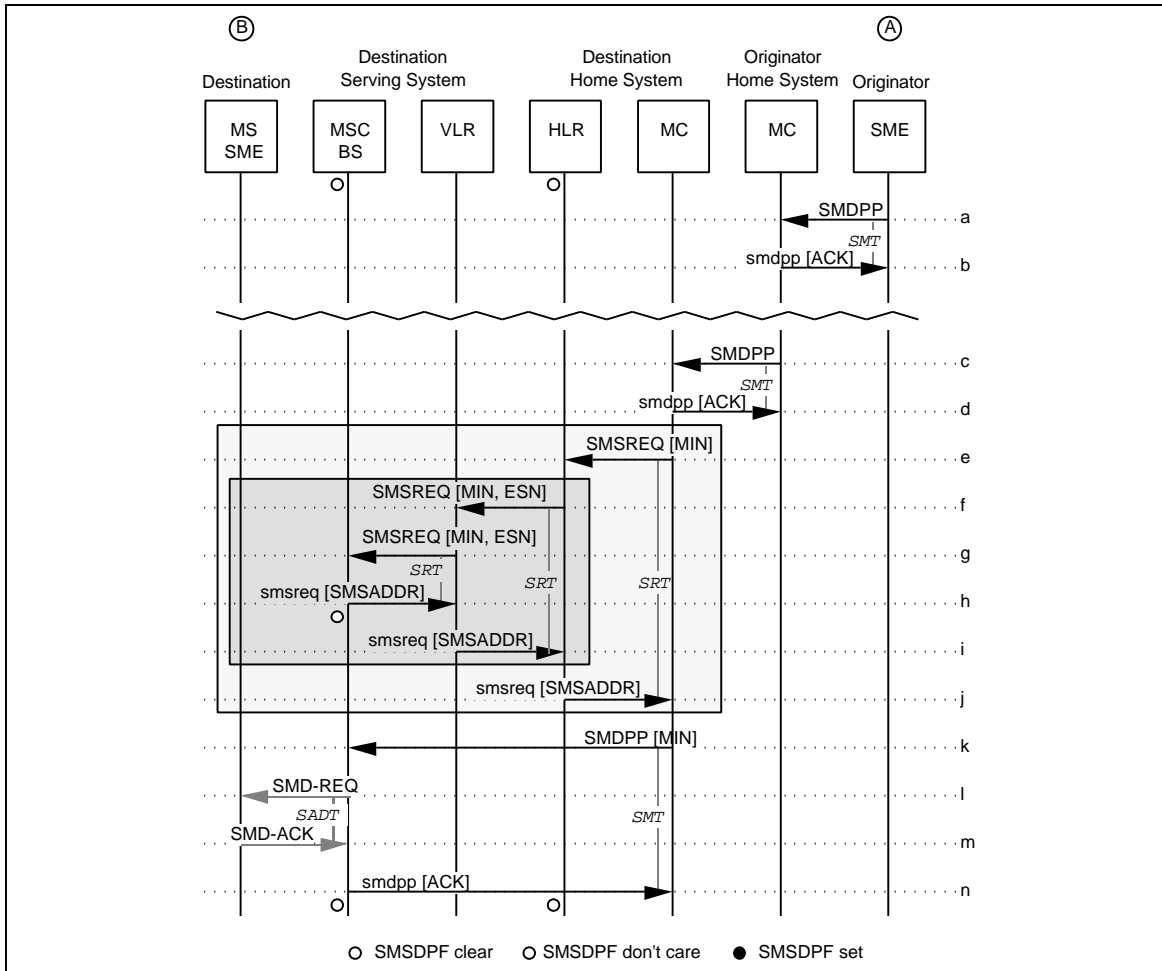

Figure 201 Short Message from a Fixed SME with Originating Supplementary Services to an Active MS-Based SME

1
2
3
4
5
6
7
8
9
10
11
12
13
14
15
16
17
18
19
20
21
22
23
24
25
26
27
28
29
30
31
32
33
34
35
36
37
38
39
40
41
42
43
44
45
46
47
48
49
50
51
52
53
54
55
56
57
58
59
60

- a. The MC receives and accepts an **SMDPP** requesting delivery of an SMS message to an MS-based SMEÉ
- b. Éand responds with an **smdpp** positive acknowledgment (which may include an **SMS_BearerData** parameter if there is bearer data to return). At this point, the originator's MC originating supplementary services, such as delayed delivery, may be performed before proceeding.
- c-n. Same as Section 7.1, Steps f-q.

7.6 Short Message from an MS-Based SME to a Fixed SME

This scenario describes short message delivery from an MS-based SME to a fixed SME, implicitly bypassing the MC; (SMS supplementary services are not possible).

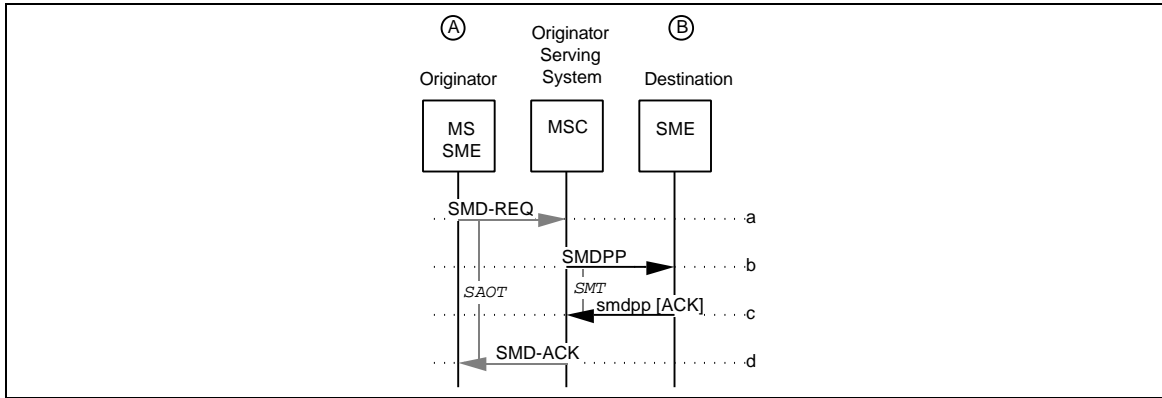

Figure 202 Short Message from an MS-Based SME to a Fixed SME

- a. The MS-based SME formulates and sends an air interface **SMD-REQUEST** message to the serving MSC.

Parameters	Usage	Type
SMS_OriginalDestination-Address	Network address of the destination SME; i.e., {B}	R
SMS_OriginalOriginating-Address	Network address of the originating SME; i.e., {A}	R
SMS_TeleServiceIdentifier	Identification of the teleservice, used for interpreting the SMS_BearerData.	R
SMS_BearerData	Any desired message as modified per terminating supplementary services.	R

- b. The serving MSC converts the **SMD-REQUEST** message into an **SMDPP** message and forwards it toward the destination SME. The parameters are as in Step a.
- c. The destination SME accepts the request by returning an **smdpp** message to the originating MSC. The **smdpp** may include an **SMS_BearerData** parameter if there is bearer data to return.
- d. The MSC converts the **smdpp** message into an air interface **SMD-ACK** message. The MS-based SME correlates the response with the original request.

7.7 Short Message from an MS-Based SME with Originating SMS Supplementary Services to a Fixed SME

This scenario describes a successful short message delivery to a fixed SME from an MS-based SME via the MS-based SME's MC, invoking SMS originating supplementary services.

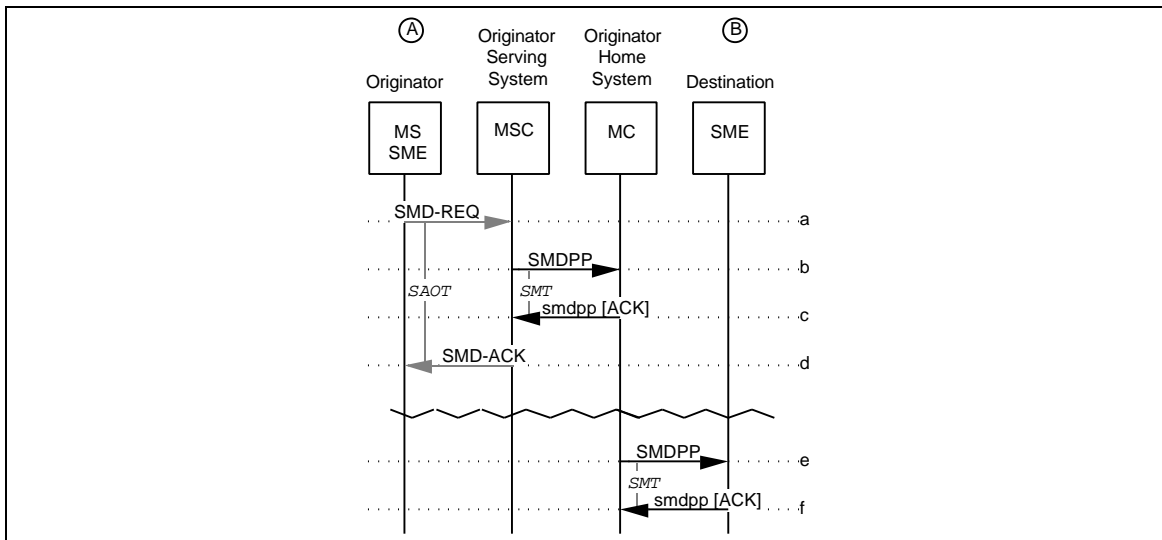

Figure 203 Short Message from an MS-Based SME with Originating SMS Supplementary Services to a Fixed SME

- a. Same as Section 7.6, Step-a, except the SMD-REQUEST message contains the following additional parameter:

Parameters	Usage	Type
SMS-DestinationAddress	Network address of the originating SME's MC; i.e., {A=>A's MC}	R

- b. Same as Section 7.6, Step b, except the message is routed to the originator's home MC instead of directly toward the original destination.
- c-d. Same as Section 7.6, Steps c-d.
- e-f. Same as Section 7.6, Steps b-c, respectively, except that the message is being initiated from the originator's MC instead of the serving MSC.

7.8 Successful Short Message Between Two MS-Based SMEs

This scenario describes a successful short message delivery between two MS-based SMEs via the destination SME's MC (terminating SMS supplementary services are possible).

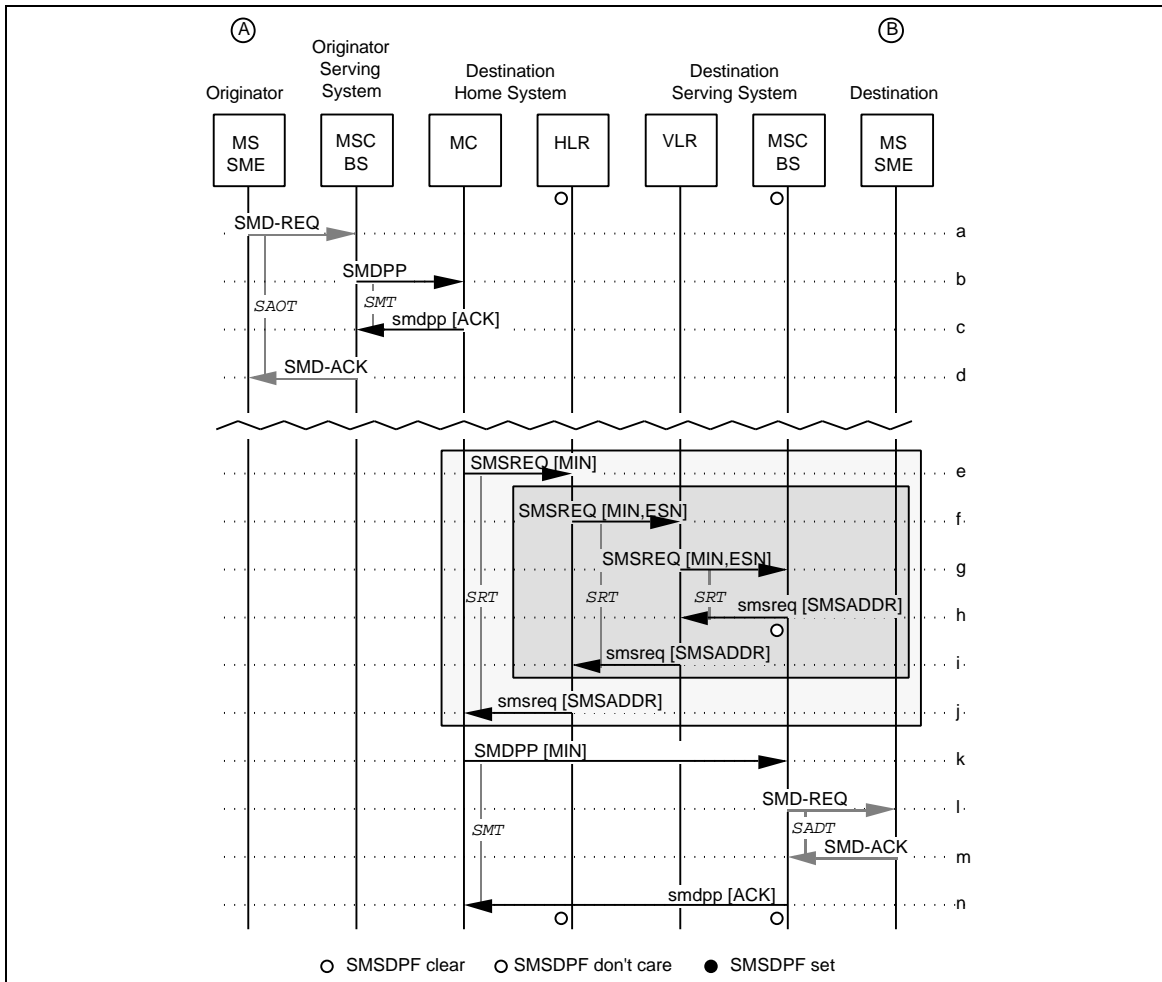

Figure 204 Successful Short Message Between Two MS-Based SMEs

a-d. Same as Section 7.6, Steps a-d, except the message is delivered to the destination MS-based SME's MC instead of directly to the destination SME.

e-n. Same as Section 7.1, Steps h-q, respectively.

7.9 Short Message Between Two MSs with Originating SMS Supplementary Services

This scenario describes a successful short message delivery between two MS-based SMEs via both their MCs, invoking originating SMS supplementary services (terminating SMS supplementary services are also possible).

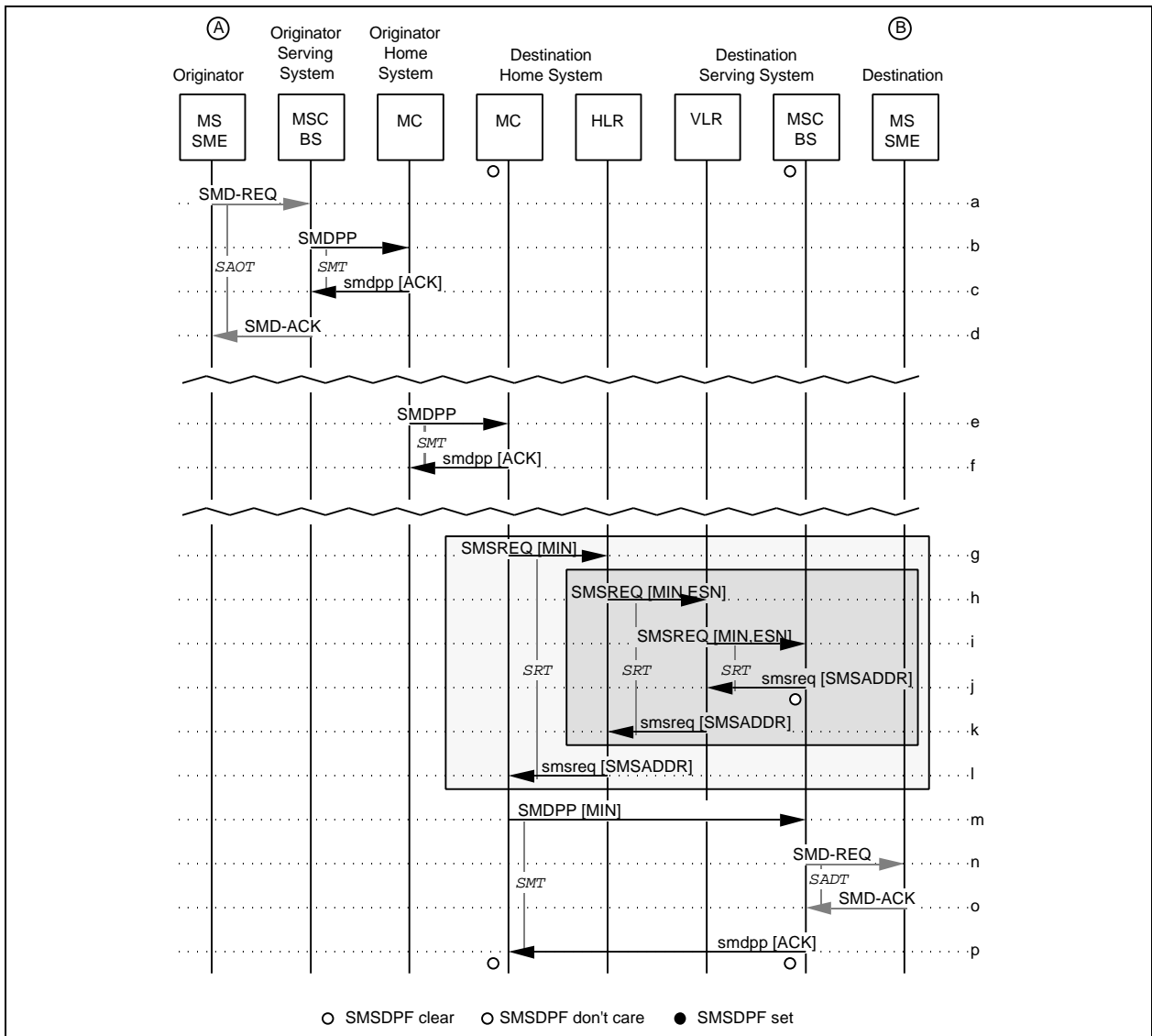

Figure 205 Short Message Between Two MS-Based SMEs with Originating SMS Supplementary Services

1
2
3
4
5
6
7
8
9
10
11
12
13
14
15
16
17
18
19
20
21
22
23
24
25
26
27
28
29
30
31
32
33
34
35
36
37
38
39
40
41
42
43
44
45
46
47
48
49
50
51
52
53
54
55
56
57
58
59
60

- a-d. Same as Section 7.6, Steps a-d, except the message is delivered to the originator's MC instead of directly to the destination SME. The originator's MC may perform originating supplementary services, such as, delayed delivery, for the received message.
- e-f. Same as Section 7.6, Steps b-c, respectively, except the message is between the originator's MC and the destination MC. The destination MC may perform supplementary services for the received message.
- g-p. Same as 7.1 Steps h-q.

7.10 Postponed SMSRequest without Current Address

This scenario describes an SMSRequest operation where the MS of a destination MS-based SME is temporarily unavailable. Notification has been requested; the MSC set its *SMS Delivery Pending Flag*.

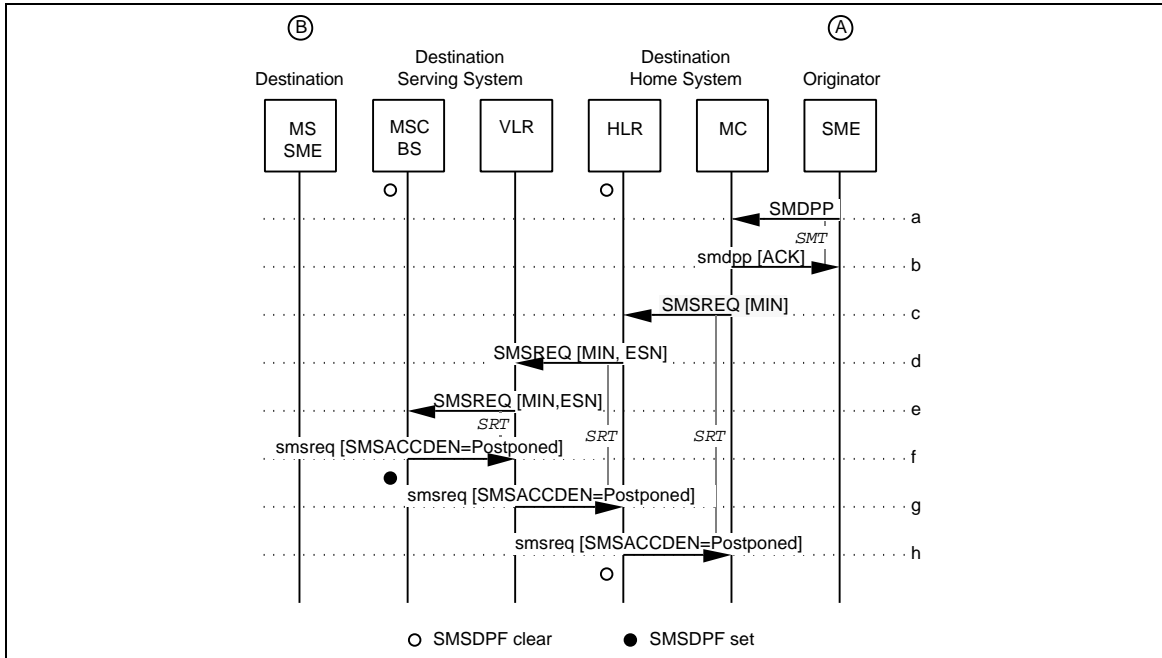

Figure 206 Postponed SMSRequest without Current Address

- a. The MC receives and accepts an SMDPP requesting delivery of an SMS message to an MS-based SME.
- b. The MC responds with an smdpp positive acknowledgment (which may include an SMS_BearerData parameter if there is bearer data to return).
- c. Steps c-h are executed because the MC does not have a current, temporary SMS routing address and status for the addressed MS-based SME. The MC sends an SMSREQ to the HLR serving the MS, containing the addressed SME.
- d. Steps d-g are executed because the HLR does not have a current temporary SMS routing address and status for the addressed MS-based SME. If the SMS address is not current or the Serving MSC is not SMS capable, the HLR sets its *SMS Delivery Pending Flag*. The HLR forwards the SMSREQ to the VLR serving the MS, containing the addressed SME.
- e. The VLR forwards the SMSREQ to the MSC serving the MS, containing the addressed SME.

- f. The MS is temporarily unavailable for short message delivery and notification was requested. The MSC sets its *SMS Delivery Pending Flag*. The MSC responds with an *smsreq* containing a postponed indication.

Parameters	Usage	Type
SMSACCDEN	SMS_AccessDeniedReason = <i>postponed</i>	R

- g. The VLR forwards the *smsreq* toward the HLR.
 - h. The HLR responds with an *smsreq* toward the MC.
- The MC should wait for notification.

7.11 Postponed SMDPP

This scenario describes an SMDPP operation where the MS of a destination MS-based SME is temporarily unavailable. Notification has been requested and the MSC sets its *SMS Delivery Pending Flag*.

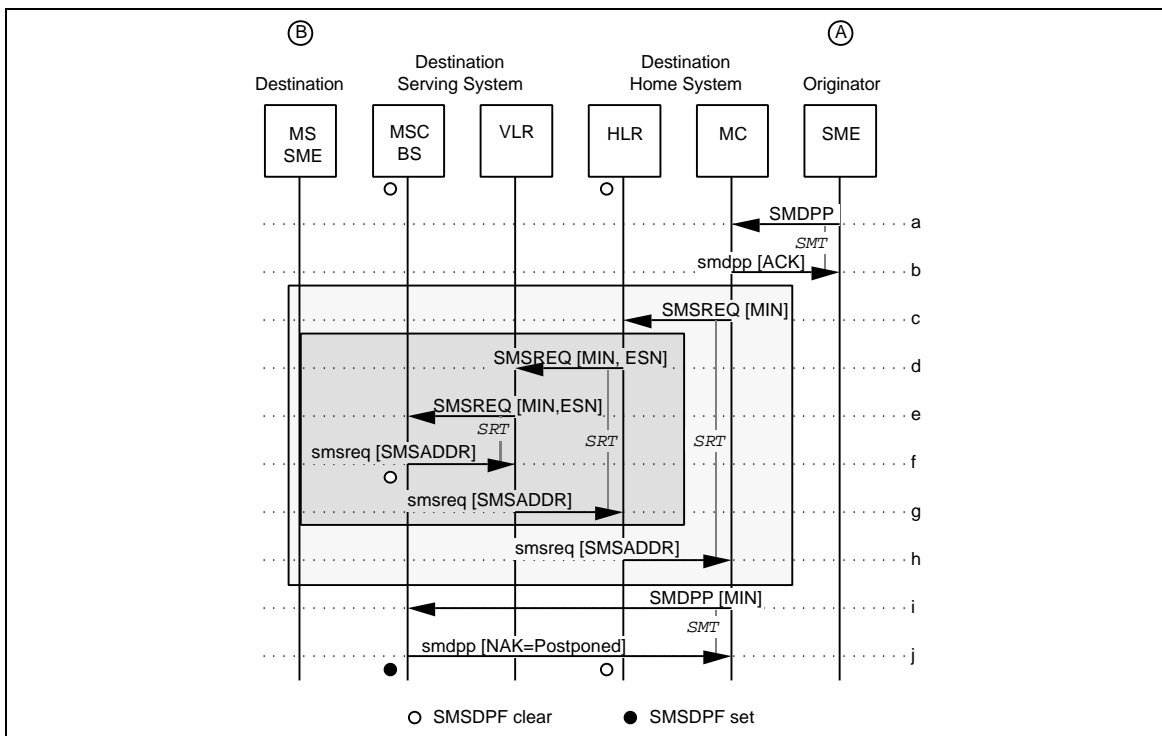

Figure 207 Postponed SMDPP

- a. The MC receives and accepts an SMDPP requesting delivery of an SMS message to an MS-based SME.
- b. The MC responds with an *smdpp* positive acknowledgment (which may include an SMS_BearerData parameter if there is bearer data to return).
- c-h. Same as Section 7.1 Steps h-m.

- 1
2
3 i. The destination MC forwards the **SMDPP** toward the destination SME using the
4 temporary SMS routing address for the MS-based SME.

5
6
7
8

Parameters	Usage	Type
MIN	Mobile Identification Number.	R

- 9 j. The addressed MS is temporarily unavailable for short message delivery and
10 notification was requested. The MSC translates the **SMDPP** into an **smdpp** negative
11 acknowledgment carried by the **SMS_CauseCode** indicating delivery is postponed and
12 returns it to the source of the corresponding **SMDPP**. The MSC sets its *SMS Delivery*
13 *Pending Flag*. The **smdpp** may include an **SMS_BearerData** parameter.

14
15 The MC should wait for notification.

16
17
18 **7.12 Roaming Between SMS-Capable Systems with Pending**
19 **Postponed Delivery**
20

21
22 This scenario describes roaming between SMS-capable MSCs. The new MSC-2 sets its
23 *SMS Delivery Pending Flag*.
24
25
26
27
28
29
30
31
32
33
34
35
36
37
38
39
40
41
42
43
44
45
46
47
48
49
50
51
52
53
54
55
56
57
58
59
60

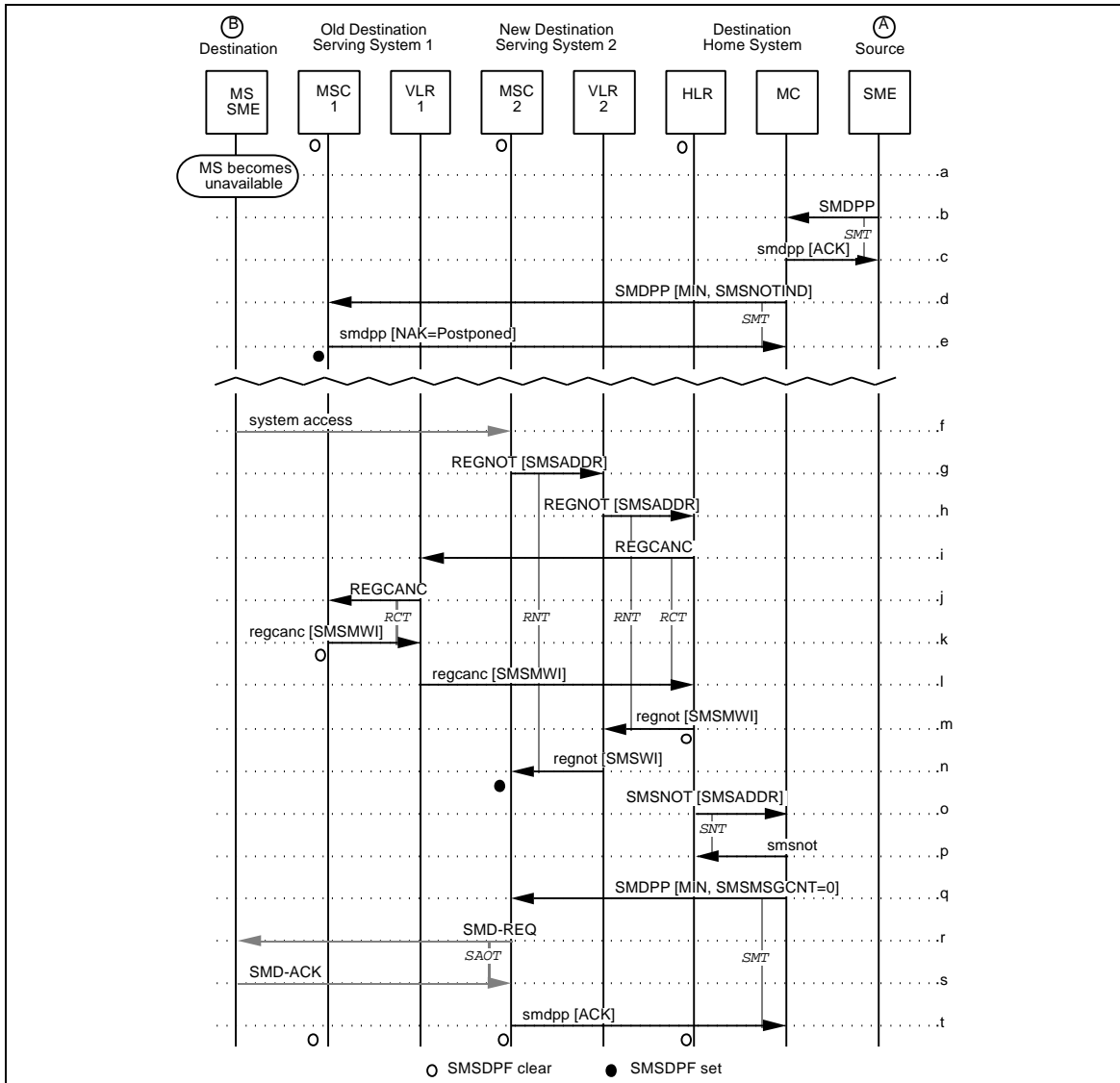

Figure 208 Roaming Between SMS-Capable Systems with Postponed Delivery

1
2
3
4
5
6
7
8
9
10
11
12
13
14
15
16
17
18
19
20
21
22
23
24
25
26
27
28
29
30
31
32
33
34
35
36
37
38
39
40
41
42
43
44
45
46
47
48
49
50
51
52
53
54
55
56
57
58
59
60

1
2
3
4
5
6
7
8
9
10
11
12
13
14
15
16
17
18
19
20
21
22
23
24
25
26
27
28
29
30
31
32
33
34
35
36
37
38
39
40
41
42
43
44
45
46
47
48
49
50
51
52
53
54
55
56
57
58
59
60

- a-e. The old MSC-1 sets the *SMS Delivery Pending Flag* because of an **SMDPP**, **SMSREQ**, or **regcanc** message.
- f. Some time later the MS supporting a SME becomes known to the new MSC-2 through registration or other system access.
- g. MSC-2 is SMS capable so it includes an **SMSADDR** with the **REGNOT** message sent to VLR-2.
- h. VLR-2 relays the **SMSADDR** with the **REGNOT** message sent to the HLR.
- i. The HLR sends a **REGCANC** message to VLR-1.
- j. VLR-1 relays the **REGCANC** message to MSC-1.
- k. MSC-1 responds by sending a **regcanc** message containing the **SMS_MessageWaitingIndicator** (**SMSMWI**) parameter to VLR-1. MSC-1 clears its *SMS Delivery Pending Flag* with the rest of the subscriber data.
- l. VLR-1 Relays the **regcanc** message with the **SMSMWI** parameter toward the HLR.
- m. The HLR seeing that MSC-2 is SMS capable, forwards the **SMSMWI** parameter in the **regnot** message to VLR-2.
- n. VLR-2 relays the **SMSMWI** parameter in a **regnot** message to MSC-2. MSC-2 receives the **SMSMWI** parameter and sets its *SMS Delivery Flag*. (MSC-2 should also do what is necessary to keep the MS awake for some period of time for a possible short message delivery).
- o. Triggered by the **SMS_MessageWaitingIndicator** (**SMSMWI**) parameter received in the **regcanc** message in Step-l, the HLR informs the MC of the MS's new SMS delivery address **SMSADDR** via an **SMSNOT** message.
- p. The MC responds with an empty **smsnot** message to confirm receipt of the address.
- q-t. Same as Section 7.1 steps n-q, except that in step t MSC-2 clears the *SMS Delivery Pending Flag* because the **SMSMSGCNT** is 0.

7.13 Roaming to an SMS-Incapable System with Pending Postponed Delivery

This scenario describes roaming from an SMS-capable MSC-1 to an SMS-incapable MSC-2. The HLR sets its *SMS Delivery Pending Flag*.

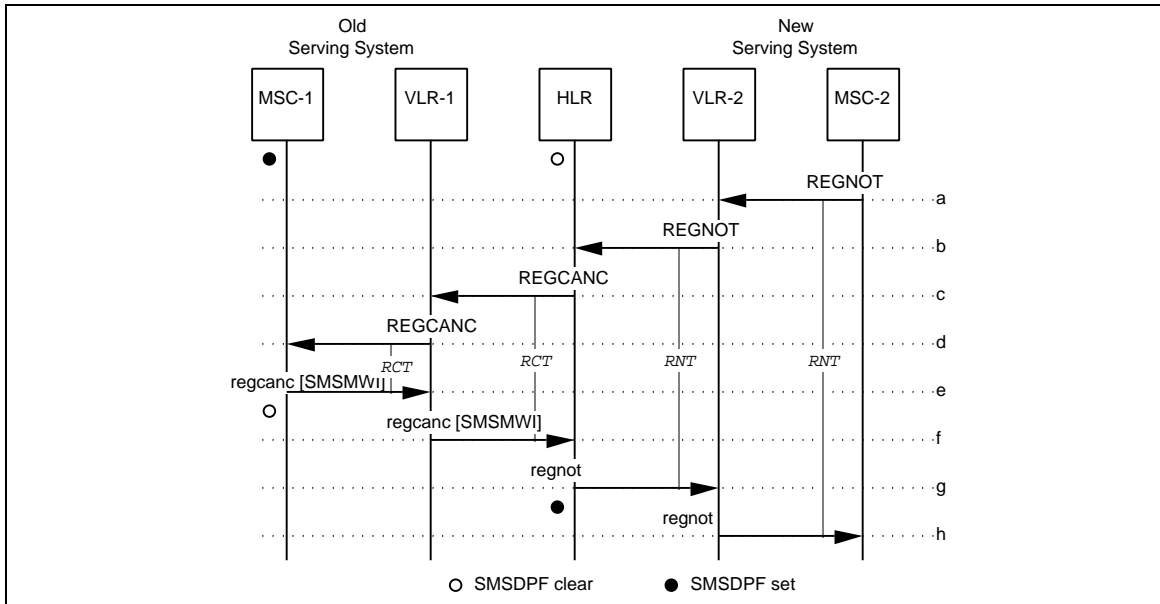

Figure 209 Roaming to an SMS-Incapable System with Pending Postponed Delivery

- a-h. This scenario follows the normal registration message flows of Section 5.1.1 with the following exceptions.
- e. MSC-1 responds by sending a **regcanc** message containing the **SMS_MessageWaitingIndicator (SMSMWI)** to the requesting VLR. The MSC clears its *SMS Delivery Pending Flag* with the rest of the subscriber data.
- f. VLR-1 relays the **SMSMWI** parameter toward the HLR in the **regcanc** message. The HLR receives the **SMSMWI** parameter and not seeing the **SMSADDR** on the **REGNOT** message is aware that MSC-2 is not SMS capable. The HLR sets its *SMS Delivery Pending Flag*.

7.14 Roaming to an SMS-Capable System with Pending Postponed Delivery

This scenario describes roaming from an old SMS-incapable MSC-1 to a new SMS-capable MSC-2. The new MSC sets its *SMS Delivery Pending Flag*.

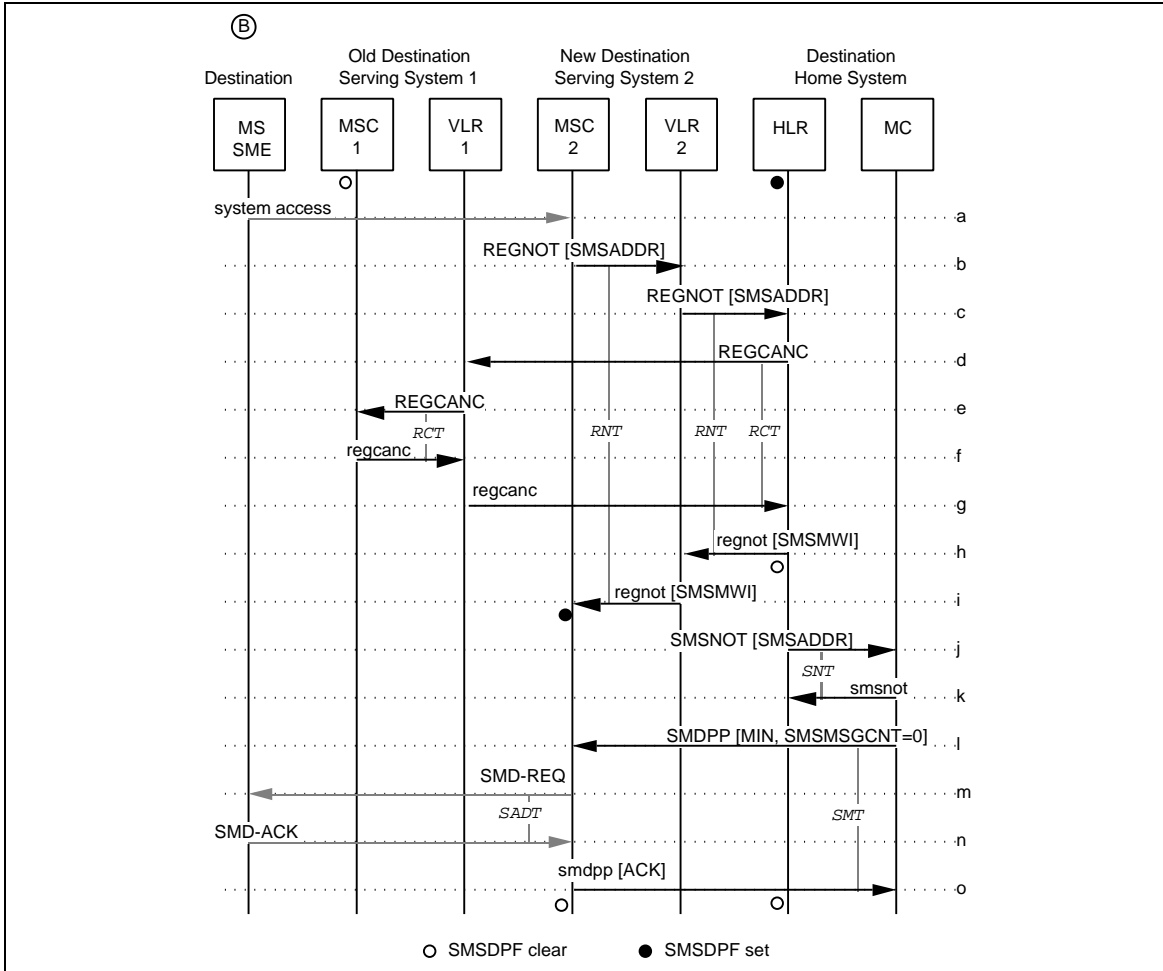

Figure 210 Roaming to an SMS-Capable System with Pending Postponed Delivery

1
2
3
4
5
6
7
8
9
10
11
12
13
14
15
16
17
18
19
20
21
22
23
24
25
26
27
28
29
30
31
32
33
34
35
36
37
38
39
40
41
42
43
44
45
46
47
48
49
50
51
52
53
54
55
56
57
58
59
60

The HLR sets the *SMS Delivery Pending Flag* because of an *MSI NACT* or *regcanc* message.

- a. Some time later, the MS accesses the new serving system, MSC-2.
- b. MSC-2 is SMS capable so it includes an *SMSADDR* with the *REGNOT* message sent to VLR-2.
- c. VLR-2 relays the *SMSADDR* with the *REGNOT* message sent to the HLR.
- d. The HLR sends a *REGCANC* message to VLR-1.
- e. VLR-1 relays the *REGCANC* message to MSC-1.
- f. MSC-1 responds by sending the *regcanc* message to VLR-1.
- g. VLR-1 relays the *regcanc* message to the HLR.
- h. The HLR seeing that MSC-2 is SMS capable, forwards the *SMSMWI* parameter in a *regnot* message to VLR-2.
- i. VLR-2 relays the *SMSMWI* parameter in a *regnot* message to MSC-2. MSC-2 receives the *SMSMWI* parameter and sets its *SMS Delivery Pending Flag*. (MSC-2 should also do what is necessary to keep the MS awake for some period of time for a possible short message delivery).
- j. The HLR, having an *SMS Delivery Pending Flag* set, sends an *SMSNOT* message with the new *SMS_Address* to the MC serving the indicated MS.
- k. The MC confirms receipt of the message by responding with an *smsnot* message.
- l-o. Same as Section 7.1 steps n-q, except that in Step-o MSC-2 clears the *SMS Delivery Pending Flag* because the *SMSMSGCNT* is 0.

7.15 Local Roaming Between SMS-Capable Systems with Pending Postponed Delivery

This scenario describes roaming between SMS-capable MSCs served by the same VLR. The new MSC sets its *SMS Delivery Pending Flag*.

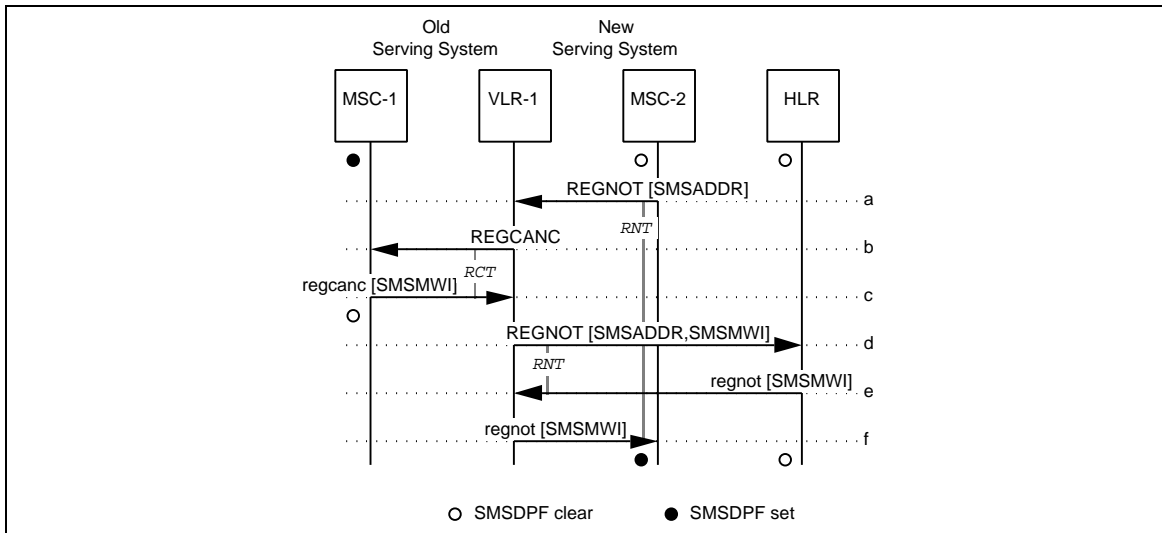
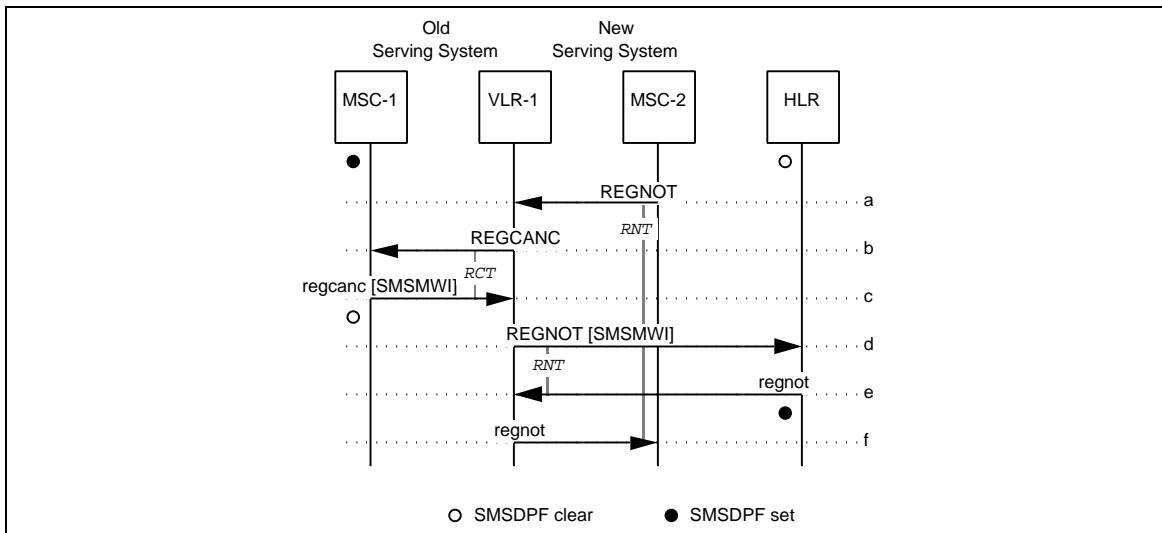

Figure 211 Local Roaming Between SMS-Capable Systems with Pending Postponed Delivery

- a. MSC-2 is SMS capable so it includes an SMSADDR with the REGNOT message sent to its VLR.
- b. VLR-1 realizes that the MS is registered to another MSC under its control. It sends a REGCANC message to cancel the previous registration.
- c. MSC-1 responds by sending a regcanc message containing the SMS_MessageWaitingIndicator (SMSMWI) to the requesting VLR. The MSC clears its *SMS Delivery Pending Flag* with the rest of the subscriber data.
- d. The VLR registers the new SMSADDR and SMSMWI parameter with a REGNOT message sent to the MS's HLR.
- e. The HLR accepts the registration with a regnot message including the SMSMWI parameter.
- f. VLR-1 relays the SMSMWI parameter in a regnot message to MSC-2. MSC-2 receives the SMSMWI parameter and sets its *SMS Delivery Pending Flag*.

7.16 Local Roaming to an SMS-Incapable System with Pending Postponed Delivery

This scenario describes roaming from an SMS-capable MSC-1 to an SMS-incapable MSC-2 served by the same VLR. The HLR sets its *SMS Delivery Pending Flag*.



21 **Figure 212 Local Roaming to an SMS-Incapable System with Pending Postponed Delivery**

- 22
23
24
25
26
27
28
29
30
31
32
33
34
35
36
37
38
39
- MSC-2 registers with a REGNOT message sent to its VLR.
 - VLR-1 realizes that the MS is registered to another MSC under its control. It sends a REGCANC message to cancel the previous registration.
 - MSC-1 responds by sending a regcanc message containing the SMS_MessageWaitingIndicator (SMSMWI) to the requesting VLR. The MSC clears its *SMS Delivery Pending Flag* with the rest of the subscriber data.
 - The VLR sends a REGNOT message to the MS's HLR including the SMSMWI parameter. The HLR upon receipt of the SMSMWI parameter sets its *SMS Delivery Pending Flag*.
 - The HLR accepts the registration with a regnot message.
 - VLR-1 relays the regnot message to MSC-2.

40 7.17 Local Roaming to an SMS-Capable System with Pending Postponed Delivery

41
42
43
44
45
46
47
48
49
50
51
52
53
54
55
56
57
58
59
60

This scenario describes roaming from an SMS-incapable MSC-1 to an SMS-capable MSC-2 service by the same VLR. The new MSC sets its *SMS Delivery Pending Flag*.

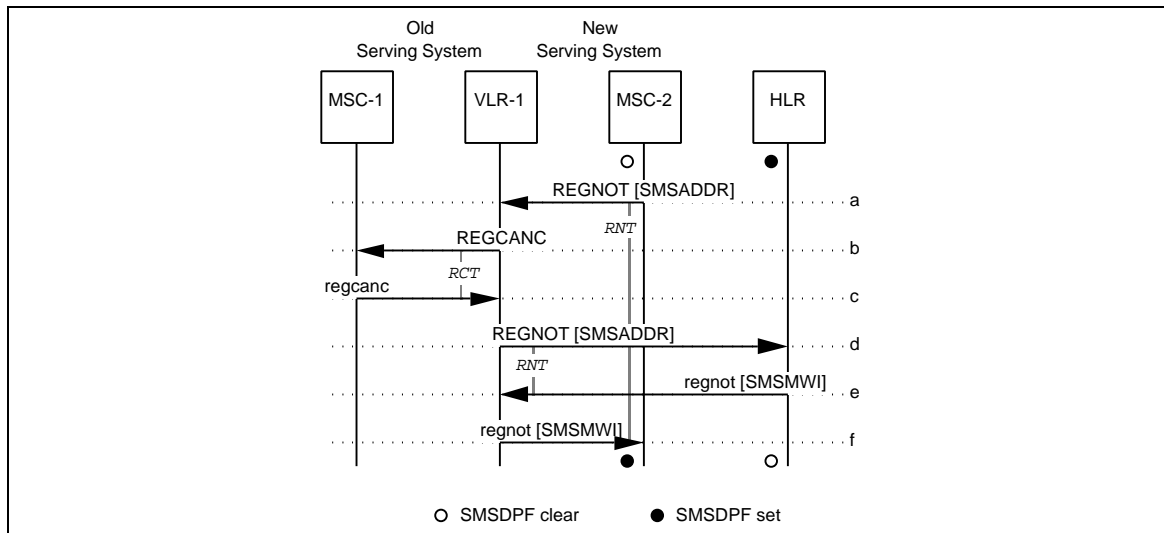

Figure 213 Local Roaming to an SMS-Capable System with Pending Postponed Delivery

- a. MSC-2 is SMS capable so it includes an SMSADDR with the REGNOT message sent to its VLR.
- b. VLR-1 realizes that the MS is registered to another MSC under its control. It sends a REGCANC message to cancel the previous registration.
- c. MSC-1 responds by sending a `regcanc` message to the requesting VLR.
- d. The VLR registers the new SMSADDR with a REGNOT message sent to the MS's HLR.
- e. The HLR accepts the registration with a `regnot` message including the SMS_MessageWaitingIndicator (SMSMWI) parameter since the new system is SMS capable. The HLR clears its *SMS Delivery Pending Flag*.
- f. VLR-1 relays the SMSMWI parameter in a `regnot` message to MSC-2. MSC-2 receives the SMSMWI parameter and sets its *SMS Delivery Pending Flag*.

7.18 MSC Deregistration with Pending Postponed Delivery

This scenario describes an SMS-capable MSC initiated deregistration of an MS-based SME. The HLR sets its *SMS Delivery Pending Flag*.

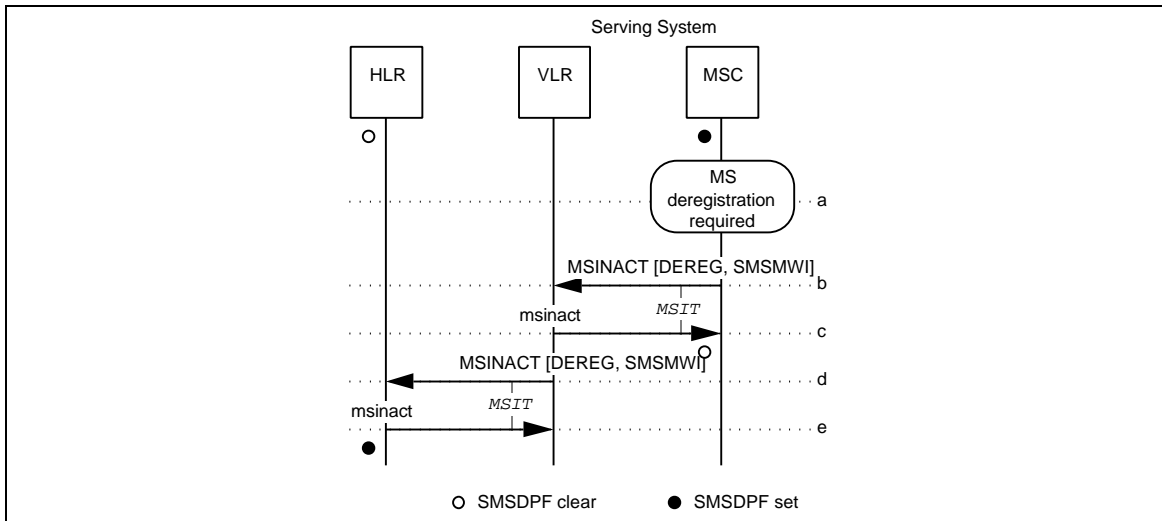

Figure 214 MSC Deregistration with Pending Postponed Delivery

- a. This scenario follows the normal deregistration message flows of Section 5.2.1 with the following exceptions.
- b. The MSC has an *SMS Delivery Pending Flag* set, so it includes an *SMS_MessageWaitingIndicator* (SSMWI) parameter with the *MSINACT* message sent to the VLR.

Additional Parameters	Usage	Type
DEREG	Indicates that the MS should be deregistered.	R

- c. The VLR responds by sending an *msi nact* to the MSC.
- d. The VLR relays the SSMWI parameter with the *MSINACT* message sent to the HLR. Parameters are the same as in Step-b.
- e. The HLR receiving the SSMWI parameter, sets its *SMS Delivery Pending Flag*.

7.19 VLR Deregistration with Pending Postponed Delivery

This scenario describes a VLR initiated deregistration of an MS-based SME at an SMS-capable MSC. The HLR sets its *SMS Delivery Pending Flag*.

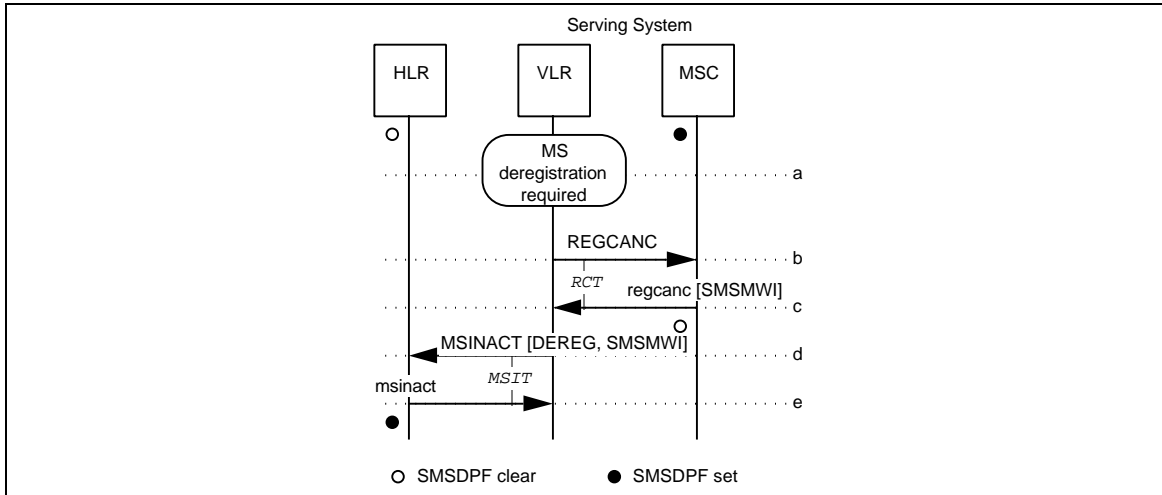

Figure 215 VLR Deregistration with Pending Postponed Delivery

- a-b. This scenario follows the normal deregistration message flows of Section 5.2.2 with the following exceptions.
- c. The MSC has its *SMS Delivery Pending Flag* set, so it includes an *SMS_MessageWaitingIndicator* (SMSMWI) parameter with the *regcanc* message sent to the VLR. The MSC clears its *SMS Delivery Pending Flag* with the rest of the subscriber information.
- d. The VLR relays the SMSMWI parameter received with the *MSI NACT* message sent to the HLR. Same parameters as in Step-b.
- e. The HLR receiving the SMSMWI parameter, sets its *SMS Delivery Pending Flag*.

7.20 Postponed MSC SMSNotification with Multiple SMDPPs

This scenario describes an MSC initiated SMSNOT operation resulting in multiple short message deliveries, previously postponed because an MS of an MS-based SME was unavailable.

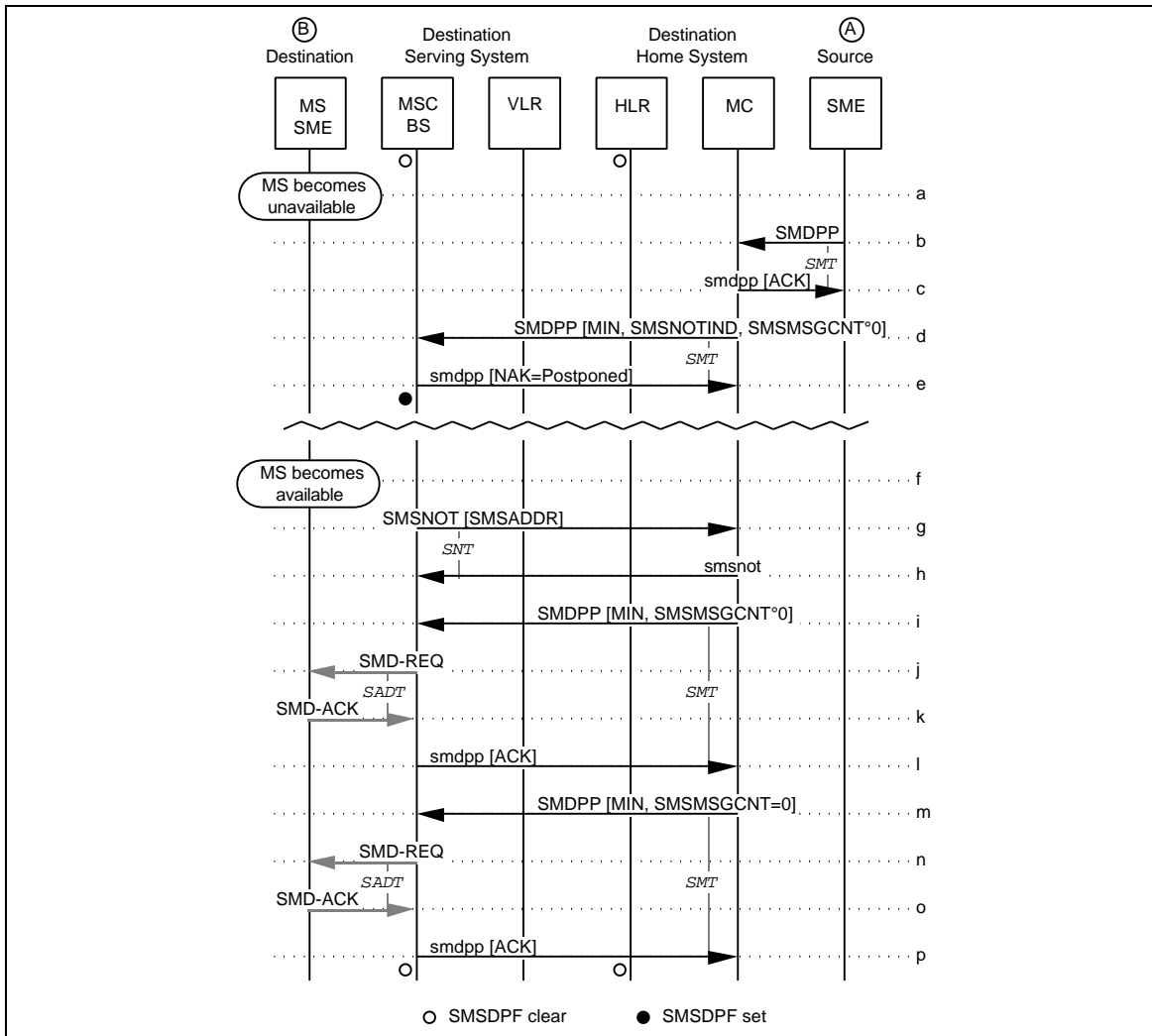

Figure 216 Postponed MSC SMSNotification with Multiple SMDPPs

- a. The MS becomes unavailable (i.e., in slotted or sleep mode).
- b. The MC receives and accepts an SMDPP requesting delivery of an SMS message to an MS-based SME

Parameters	Usage	Type
SMS_OriginalDestination-Address	Network address of the destination SME; i.e., {B}.	R
SMS_OriginalOriginating-Address	Network address of the originating SME; i.e., {A}.	R
SMS_TeleServiceIdentifier	Number of the teleservice for interpreting the SMS_BearerData.	R
SMS_BearerData	Any desired message as modified per terminating supplementary services.	R

- c. Éand responds with an **smdpp** positive acknowledgment (which may include an SMS_BearerData parameter if there is bearer data to return).
- d. The destination MC forwards the **SMDPP** toward the destination SME using the temporary SMS routing address for the MS-based SME. It includes the SMSNotificationIndicator requesting notification in the event that SMS delivery is SMS_BearerData.

Parameters	Usage	Type
MIN	Mobile Identification Number.	R
SMS_NotificationIndicator	Indication whether or not notification is requested when the MS becomes available.	R
SMS_MessageCount	Indicates the number of SMS messages waiting.	R

- e. The MSC verifies the MS unavailability; in this example, the MS is in sleep mode. Since the **SMDPP** included the SMSNotificationIndicator, the MSC returns an **smdpp** including an indication carried by the SMS_CauseCode that termination to the MS has been postponed to a later time. It then sets its *SMS Delivery Pending Flag*.
- f. Some time later, the MS becomes available.
- g. If the MS's *SMS Delivery Pending Flag* is still set and the MS is still in an SMS-capable area, the Serving MSC sends an **SMSNOT** to the MC (i.e., The MSC should also do what is necessary to keep the MS awake for some period of time for a possible short message delivery.)
- h. The MC returns an empty **smsnot** to the Serving MSC.
- i. The destination MC sends an **SMDPP** toward the destination SME using the temporary SMS routing address for the MS-based SME. In this example, two messages are waiting for delivery; therefore, the MC includes the SMS_MessageCount parameter indicating that one SMS message is pending delivery. Parameters are the same as in Step-d.
- j. The MSC, BS, or both forward the **SMD-REQUEST** toward the destination SME using the air interface address of the MS-based SME (usually B's MIN).
- k. The destination SME responds with an automatic acknowledgment (**SMD-ACK**) to signal the acceptance of the **SMD-REQUEST**.
- l. The MSC translates the **SMD-ACK** into an **smdpp** positive acknowledgment and returns it to the source of the corresponding **SMDPP**.

- 1
2
3 m. The destination MC sends another SMDPP toward the destination SME using the
4 temporary SMS routing address for the MS-based SME. The MC includes the
5 SMS_MessageCount parameter indicating that zero SMS messages are pending
6 delivery. Parameters are the same as in Step-d.
7
8 n. The MSC, BS, or both forward the SMD-REQUEST toward the destination SME
9 using the air interface address of the MS-based SME (usually B's MIN).
10
11 o. The destination SME responds with an automatic acknowledgment (SMD-ACK) to
12 signal the acceptance of the SMD-REQUEST.
13
14 p. The MSC translates the SMD-ACK into an *smdpp* positive acknowledgment and
15 returns it to the source of the corresponding SMDPP. Since the SMSMSGCNT is 0, the
16 MSC then clears the MS's *SMS Delivery Pending Flag*.
17

18 7.21 Short Message Between MSC-Based SME and MS-Based 19 SME 20 21

22 This scenario describes short message delivery between an MSC-based SME and an MS-
23 based SME, implicitly bypassing the MC (supplementary SMS services are not possible).
24
25

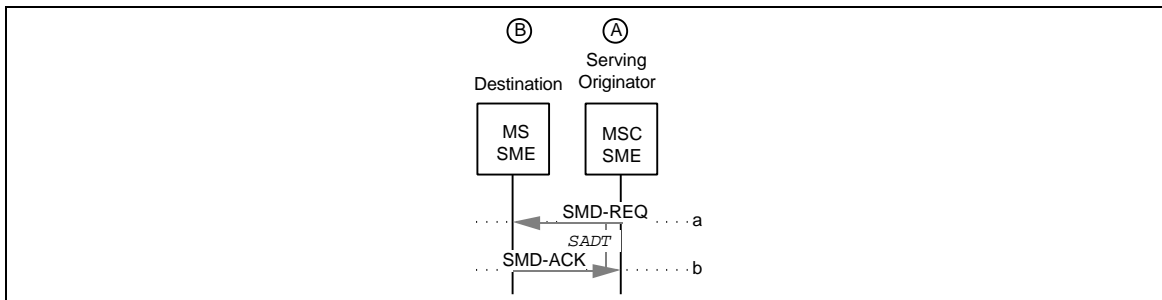

26
27
28
29
30
31
32
33
34
35
36
37 **Figure 217 Short Message Between MSC-Based SME and MS-Based SME**

- 38
39 a-b. Same as Section 7.1, Steps o-p, respectively. Since the MSC knows the location of the
40 MS, it is not necessary for the MSC to send its short messages through the MS-based
41 SME's home MC. Only immediate delivery messages (No Notification) are supported
42 for this type of communication.
43
44
45
46
47
48
49
50
51
52
53
54
55
56
57
58
59
60

7.22 Short Message Between HLR-Based SME and MS-Based SME

This scenario describes short message delivery between an HLR-based SME and an MS-based SME, implicitly bypassing the MC (supplementary SMS services are not possible).

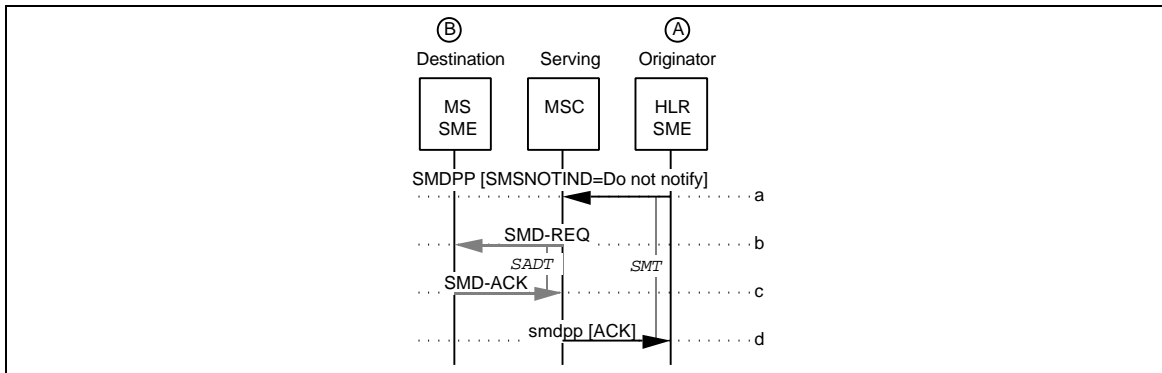

Figure 218 Short Message Between HLR Based SME and MS-Based SME

a-d. Same as Section 7.1, Steps n-q, respectively, except the sequence is initiated by the MS's HLR instead of the MS-based SME's home MC. Since the HLR knows the location of its MSs, it is not necessary for the HLR to send its short messages through the MS-based SME's home MC. Only immediate delivery (No Notification) messages are supported for this type of communication.

7.23 Short Message Between MS and MC for MC-Based Feature Control

This scenario describes short message delivery between an MS-based SME and its MC-based SME, for feature control applications.

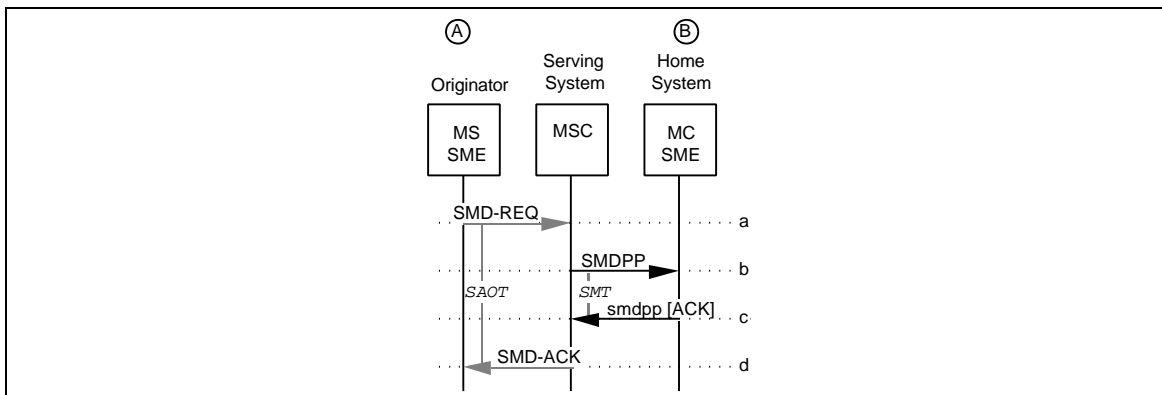

Figure 219 Short Message Between MS-Based SME and MC for MC-Based Feature Control

a-d. Same as Section 7.6, Steps a-d, except that the SMS_BearerData parameter contains feature activation and response character sequences.

7.24 Short Message to MS-Based SME After Handoff

This scenario describes short message delivery terminating at an MS-based SME after the MS (on a voice call) has undergone an intersystem handoff.

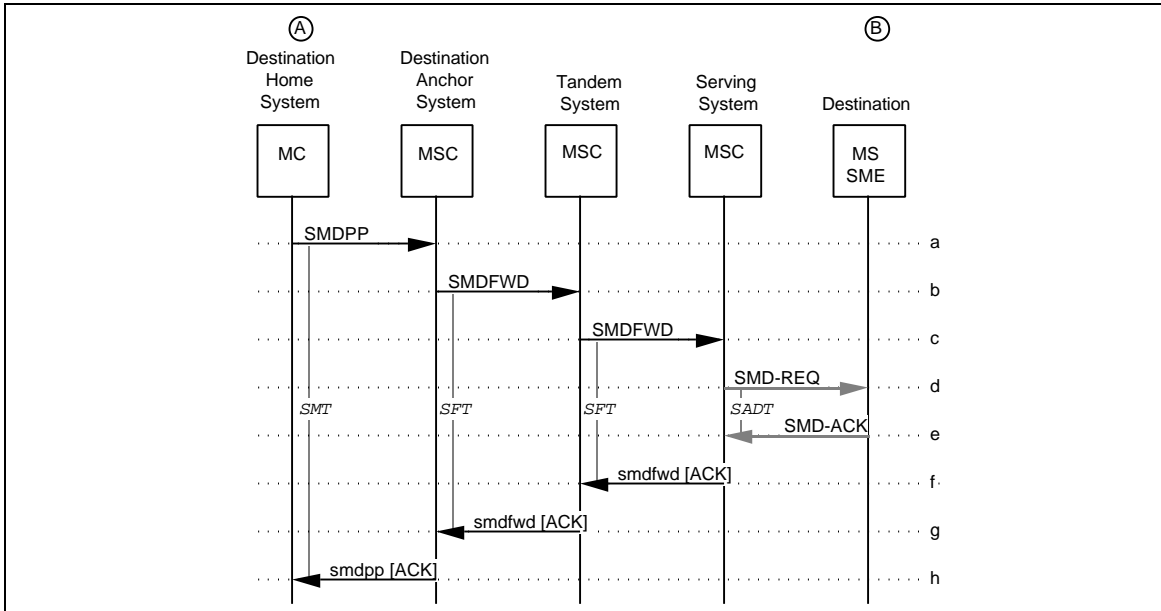

Figure 220 Short Message to MS-Based SME After Handoff

- 1
2
3
4
5
6
7
8
9
10
11
12
13
14
15
16
17
18
19
20
- a. The Anchor MSC receives an **SMDPP** message for an MS-based SME that has been handed off to another system.

Parameters	Usage	Type
SMS_OriginalDestination-Address	Network address of the destination SME; i.e., {B}.	R
SMS_OriginalOriginating-Address	Network address of the originating SME; i.e., {A}.	R
SMS_TeleServiceIdentifier	Identification of the teleservice, used for interpreting the SMS_BearerData.	R
SMS_BearerData	Any desired message as modified per terminating supplementary services.	R

- b. The Anchor MSC determines the destination MIN and ESN and forwards the **SMDFWD** message toward the serving system. The parameters are as in Step-a with the following additional parameters:

Parameters	Usage	Type
MIN	MIN of the destination MS. Use only when the MIN and the OriginalDestinationAddress are different for an MS-based SME.	R
ESN	ESN of the destination MS.	R
IMSCCID	Identify the intersystem circuit used.	R

- 21
22
23
24
25
26
27
28
29
30
31
32
33
34
35
36
37
38
39
40
- c. A Tandem MSC, receiving an **SMDFWD** message, adjusts the InterMSCCircuitID parameter to identify the circuit between it and the Serving MSC, and forwards the **SMDFWD** toward the serving system.
- d. The Serving MSC converts the **SMDFWD** message into an air interface **SMD-REQUEST** message and sends it toward the addressed MIN.
- e. The MS-based SME responds with an air interface positive acknowledgment **SMD-ACK** message which may contain an SMS_BearerData parameter.
- f. The Serving MSC converts the positive acknowledgment into an **smdfwd** response message and sends it up the handoff chain.

Parameters	Usage	Type
ACK [SMS_BearerData]	Positive acknowledgment signal: Used to transport the bearer data, if available.	O

- 41
42
43
44
45
46
47
48
49
50
51
52
53
54
55
56
57
58
59
60
- g. A Tandem MSC relays the **smdfwd** response back toward the Anchor MSC.
- h. The Anchor MSC converts the **smdfwd** response into a positive acknowledgment **smdpp** response and sends this back to the initiator.

7.25 Short Message from MS-Based SME After Handoff

This scenario describes short message delivery originating at an MS-based SME after the MS (on a voice call) has undergone an intersystem handoff.

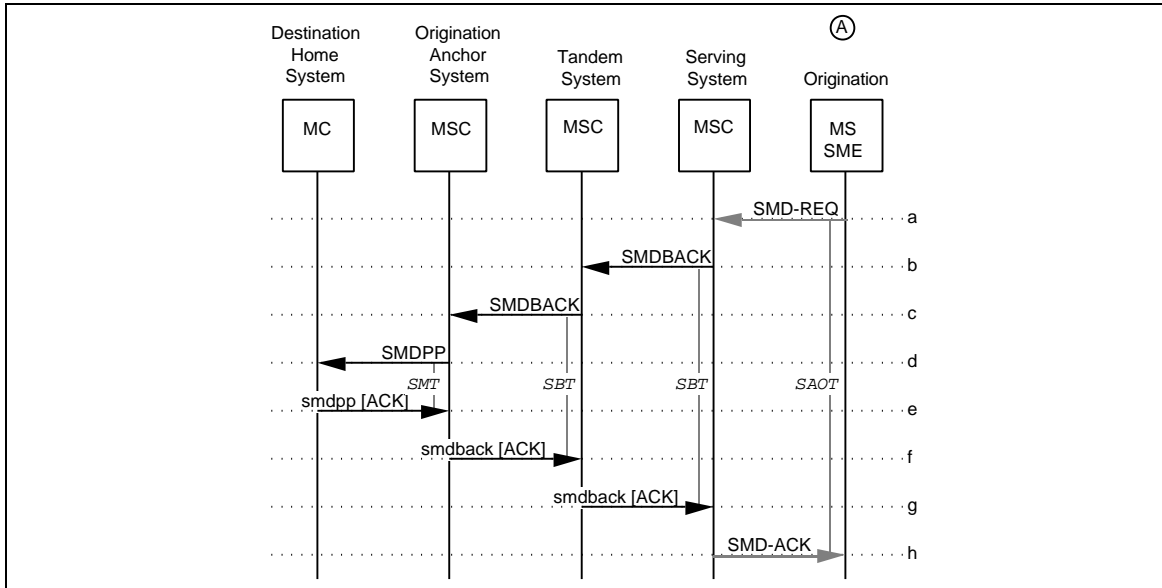

Figure 221 Short Message from MS-Based SME After Handoff

- 1
2
3
4 a. The MS-based SME, after being handed off to another system, prepares and sends a SMD-REQUEST message.

5
6
7
8
9
10
11
12
13
14
15
16

Parameters	Usage	Type
SMS_OriginalDestination-Address	Network address of the destination SME; i.e., {B}.	R
SMS_OriginalOriginating-Address	Network address of the originating SME; i.e., {A}.	R
SMS_TeleserviceIdentifier	Identification of the teleservice, used for interpreting the SMS_BearerData.	R
SMS_BearerData	Any desired message as modified per terminating supplementary services.	R

- 17
18 b. The Serving MSC determines the MIN and ESN of the originating MS and forwards the SMDBACK message toward the anchor system. The parameters are as in Step a with the following additional parameters:

19
20
21
22
23
24
25
26
27
28
29
30
31
32
33

Parameters	Usage	Type
MIN	MIN of the originating MS. Use only when the MIN and the SMS_OriginalOriginating-Address are different for an MS-based SME.	R
ESN	ESN of the originating MS.	R
IMSCCID	Identify the intersystem circuit used.	R
SMS_OriginalDestination-Address	Network address of the destination SME; i.e., {B}.	R
SMS_OriginalOriginating-Address	Network address of the originating SME; i.e., {A}.	R

- 34
35 c. A Tandem MSC, receiving a SMDBACK message, adjusts the InterMSCCircuitID parameter to identify the circuit between it and the Anchor MSC, and forwards the SMDBACK toward the anchor system.
- 36
37
38
39 d. The Anchor MSC converts the SMDBACK message into the network SMDPP message and sends it toward the addressed destination (SME or MC), if it is acceptable.
- 40
41
42 e. The destination (SME or MC) responds with an smdpp message containing the following parameters:

43
44
45
46

Parameters	Usage	Type
SMS_BearerData	Any desired message	R

- 47
48 f. The Anchor MSC converts the positive acknowledgment into a smdback response message and sends it down the handoff chain.
- 49
50 g. A Tandem MSC relays the smdback response back toward the Serving MSC.
- 51
52
53 h. The Serving MSC converts the smdback response into an air interface SMD-ACK response and sends this back to the MS-based SME.
- 54
55
56
57
58
59
60

Annex A (normative): Assumptions

This Annex is normative.

A.1. Assumptions for MS Authentication

1. The TR-45 Cellular Authentication and Voice Encryption algorithm (CAVE) shall be executed in an Authentication Center (AC), associated with the Home Location Register (HLR), or in the Visitor Location Register (VLR) if SSD is shared, and in the Mobile Station (MS). The HLR and MSC shall not be required to execute CAVE. As indicated below, the AC is a *functional* entity in the network reference model that may or may not be located within, and be distinguishable from, the HLR. (The interface between the AC and the HLR is for further study.)
2. A-keys shall be maintained only by the AC and the MS. Shared Secret Data (SSD-A and SSD-B) shall be maintained in the AC, MS, and optionally in the VLR. Procedures to update SSD shall be initiated only by the AC, based on administrative procedures at the AC/HLR. For example, SSD may be regenerated during the initial service commissioning call that a new MS makes, on a per-transaction basis, when an authentication abnormality is detected, or on a periodic basis.
3. The CallHistoryCount (COUNT) shall be maintained by the AC, MS, and optionally the VLR. The AC allows COUNT to be maintained by a VLR if SSD is shared. COUNT may be updated by the AC or the VLR on a successful service request (e.g., origination attempt). Note: The COUNT update is only performed on voice or traffic channel.
4. Verification of RANDC (i.e., the most-significant eight bits of RAND) shall be performed by the serving MSC to ensure that AUTHR has been computed by the MS using an expected value of RAND.
5. The value of RAND transmitted in the Overhead Message Train of a cell shall be chosen by the controlling MSC.
6. To avoid confusion with the default zero value of RAND used by an MS, the serving MSC shall ensure that no value of RAND transmitted in the Overhead Message Train of a cell has all-zeros in the most-significant eight bits.
7. When RAND is updated, the new value shall not produce the same value of RANDC.
8. The visited system shall perform authentication of an MS before sending a Registration Notification to the HLR to prevent false changes in location at the HLR.
9. The events that initiate authentication-related transactions are different from those that initiate other intersystem transactions. For example, authentication transactions may be generated several times a day, on every system access by an MS, but registration and qualification transactions may only be required once a day or once for several days.

10. MS security violations detected by the serving system shall be reported to the AC. Procedures to deal with the security violation shall be initiated by the AC, based on administrative procedures at the AC/HLR; for example, the AC may attempt to regenerate SSD in the MS, initiate a Unique Challenge to the MS, or deny further service to the MS.
11. It may not be possible for a *TSB51* serving system to immediately execute a directive by an AC to change the SSD, issue a Unique Challenge, or update COUNT in an MS. Depending on traffic conditions and administrative practices in the serving system, it may be necessary, for example, to wait until the next call by the MS before initiating the updates. Intersystem operations shall be designed to accommodate the potentially long time between the directive being issued by the AC and the change being initiated by the serving system.
12. The AC may optionally forward Shared Secret Data (SSD) to a VLR on a subscriber basis.
13. If the SYSCAP indicates that the VLR can support CAVE, then the VLR shall perform the authentication procedures locally when the VLR is provided with the MS SSD. The VLR may initiate Unique Challenges and perform COUNT management according to its local administration practices. The VLR shall report validation failures to the AC using the AuthenticationFailureReport INVOKE and shall perform the required action as indicated in the RETURN RESULT.
14. It is assumed that when the VLR receives a REGCANC it shall also cancel the subscriber's SSD and any pending operations immediately.

A.2. Assumptions for MS Signaling Message Encryption

1. Signaling Message Encryption is a recommended service. The subscriber has no control over Signaling Message Encryption. It is a service provider option. This service is completely independent of Voice Privacy.
2. *TIA/EIA-41* intersystem messages shall not include signaling message encrypted data fields.
3. The SMEKEY is generated by the AC (or the VLR when SSD is shared) and the MS once per call.
4. If Signaling Message Encryption is currently not applied and the MS is being handed off to an MSC which supports Signaling Message Encryption, then Signaling Message Encryption shall be applied.
5. The SMEKEY can only be generated by the AC (or the VLR when SSD is shared) if authentication parameters were requested by the Serving MSC (AUTH=1 in the Overhead Message Train) and authentication was successful.
6. The AC shall forward the SMEKEY to the serving system upon successful authentication, even if Signaling Message Encryption is not supported by the serving system.

1
2
3
4
5
6
7
8
9
10
11
12
13
14
15
16
17
18
19
20
21
22
23
24
25
26
27
28
29
30
31
32
33
34
35
36
37
38
39
40
41
42
43
44
45
46
47
48
49
50
51
52
53
54
55
56
57
58
59
60

A.3. Assumptions for MS Voice Privacy

1. The Voice Privacy Mask (VPMASK) can only be generated by the AC (or the VLR when SSD is shared) if authentication parameters were requested by the Serving MSC (AUTH=1 in the Overhead Message Train) and authentication was successful.
2. VPMASK is generated by the AC (or the VLR when SSD is shared) and the MS once per call.
3. The AC shall forward the VPMASK to the HLR upon successful authentication.

Annex J : A example of the information flows with Interconnection charge billing system

*
*
*

This Annex provides some information flows with Interconnecon charge billing system.

J.1. Initial MS Registration in a New Serving System with Interconnection charge billing system

This scenario describes the registration and validation process as an MS roams from one system to another with Interconnection charge billing system.

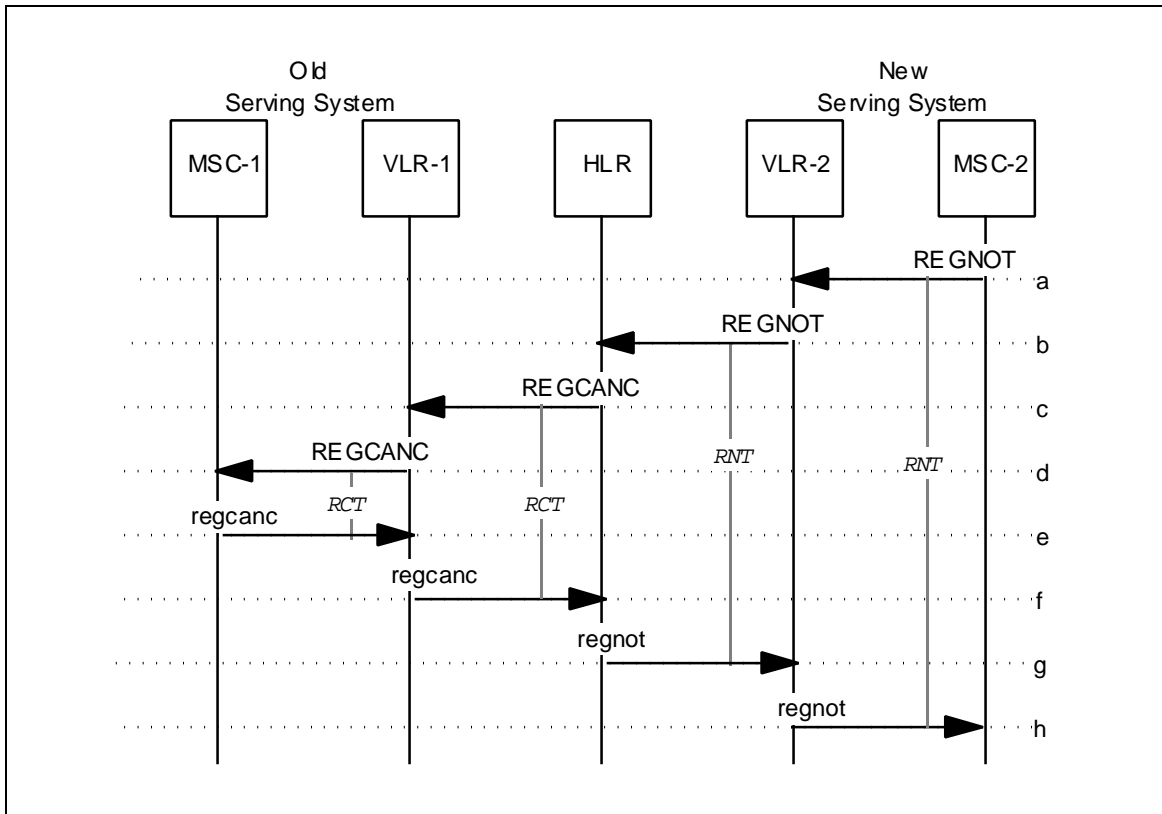

Figure J.1 Initial MS Registration in a New Serving System with Interconnection charge billing system

- After determining that a roaming MS is now within its service area, the new Serving MSC (MSC-2) sends a REGNOT to its VLR (VLR-2); MSC-2 may detect the MS's presence through autonomous registration, call origination, call termination, (i.e., a page response following a call to the roamer port) or a service order. The REGNOT includes ChargingAreaInformation and CarrierIdentificationCode parameter for Interconnection charge billing system.
- Since the MS is unknown to VLR-2, VLR-2 sends a REGNOT to the HLR associated with the MS. Note that the RegistrationNotification response from the VLR to the MSC is contingent upon the response received from the HLR.
- Since the MS was previously registered elsewhere, the HLR sends a REGCANC to the previously visited VLR (VLR-1). That VLR, upon receipt of the cancellation message, essentially removes all record of the MS from its memory.
- VLR-1 sends a REGCANC to the previously visited MSC (MSC-1). That MSC, upon

1
2
3
4
5
6
7
8
9
10
11
12
13
14
15
16
17
18
19
20
21
22
23
24
25
26
27
28
29
30
31
32
33
34
35
36
37
38
39
40
41
42
43
44
45
46
47
48
49
50
51
52
53
54
55
56
57
58
59
60

- receipt the cancellation message, essentially removes all record of the MS from its *
memory. *
- e. MSC-1 sends a `regcanc` to VLR-1. *
- f. VLR-1 sends a `regcanc` to HLR. *
- g. HLR sends a `regnot` to VLR-2. The `regnot` includes *
MobileAdditionalParty'sCategory3 parameter in Profile parameter for Interconnection *
billing charge system. *
- h. VLR-2 sends a `regnot` to MSC-2. *

J.2. CD Invocation to an Idle, Local MS with Interconnection charge billing system

This scenario describes CD invocation to an idle MS that is served by the MSC where the call originates with Intersystem charge billing system.

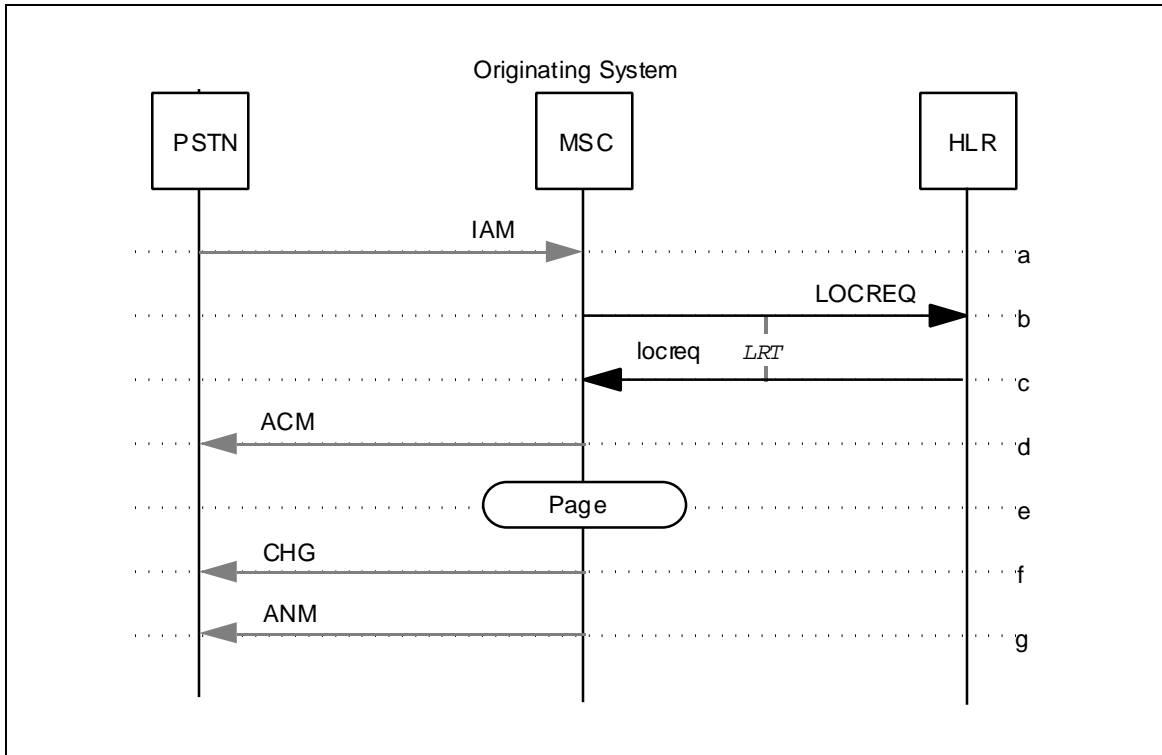

Figure J.2 CD Invocation to an Idle, Local MS with Interconnection charge billing system

- a. An IAM (Initial Address Message) used for a call origination are received by the Originating MSC.
- b. The Originating MSC sends a LOCREQ to the HLR associated with the MS; this association is made through the dialed MS address digits (which may not be the MIN).
- c. If the dialed MS address digits are assigned to a legitimate subscriber and the MS has been registered by the Originating system, HLR return the locreq to the Originating MSC. The locreq includes ChargingAreaInformation, CarrierIdentificationCode and MobileAdditionalParty'sCategory3 parameter for Interconnection charge billing system.
- d. The Originating MSC returns an ACM (Address Complete Message) to PSTN.
- e. The Originating MSC performs Page to the MS.
- f. After the step e, the Originating MSC optionally sends a CHG (Charge Information

1
2
3
4
5
6
7
8
9
10
11
12
13
14
15
16
17
18
19
20
21
22
23
24
25
26
27
28
29
30
31
32
33
34
35
36
37
38
39
40
41
42
43
44
45
46
47
48
49
50
51
52
53
54
55
56
57
58
59
60

- Message) to PSTN. *
- g. If the MS connect the call, the Originating MSC sends an ANM (Answer Message) to PSTN. *

J.3. CD Invocation to an Idle MS on Another MSC with Interconnection charge billing system

This scenario describes call delivery to an MS from PSTN that is outside the serving area of the MSC where the call originates with Interconnection charge billing system.

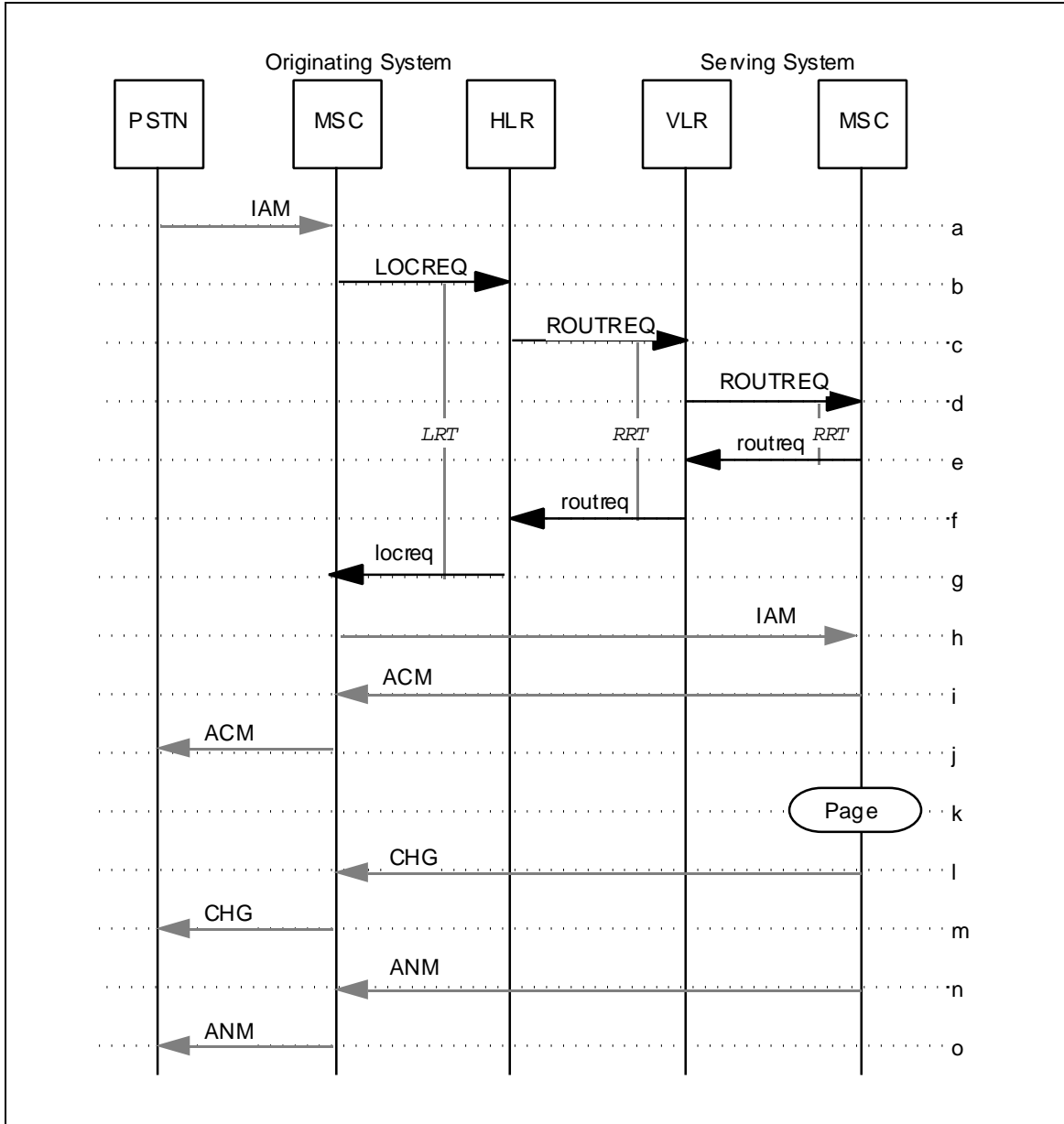

Figure J.3 CD Invocation to an Idle MS on Another MSC with Interconnection charge billing system

1
2
3
4
5
6
7
8
9
10
11
12
13
14
15
16
17
18
19
20
21
22
23
24
25
26
27
28
29
30
31
32
33
34
35
36
37
38
39
40
41
42
43
44
45
46
47
48
49
50
51
52
53
54
55
56
57
58
59
60

- a. An IAM (Initial Address Message) used for call origination is received by the Originating MSC. *
- b. The Originating MSC sends a LOCREQ to the HLR associated with the MS; this association is made through the dialed MS address digits (which may not be the MIN). *
- c. If the dialed MS address digits are assigned to a legitimate subscriber, the HLR sends a ROUTREQ to the VLR where the MS is registered. *
- d. The VLR then forwards the ROUTREQ to the current Serving MSC. *
- e. The Serving MSC allocates a TLDN (Temporary Local Directory Number), and returns this information to VLR in the routreq. *
- f. The VLR sends the routreq to the HLR. The routreq includes ChargingAreaInformation and CarrierIdentificationCode parameter for Interconnection charge billing system. *
- g. When the routreq is received by the HLR, it returns a locreq to the Originating MSC. The locreq includes ChargingAreaInformation, CarrierIdentificationCode and MobileAdditionalParty'sCategory3 parameter for Interconnection charge billing system. *
- h. The Originating MSC sends the IAM to the Serving MSC. *
- i. The Serving MSC returns an ACM (Address Complete Message) to the Originating MSC. *
- j. The Originating MSC sends the ACM to PSTN. *
- k. The Serving MSC performs Page to the MS. *
- l. After the step k, the Serving MSC optionally sends a CHG (Charge Information Message) to the Originating MSC. *
- m. The Originating MSC optionally sends the CHG to PSTN. *
- n. If the MS connects the call, the Serving MSC sends an ANM (Answer Message) to the Originating MSC. *
- o. The Originating MSC sends the ANM to PSTN. *

J.4. CFB Invocation with Interconnection charge billing system

This scenario describes CFB invocation due to the served MS being busy with Interconnection charge billing system.

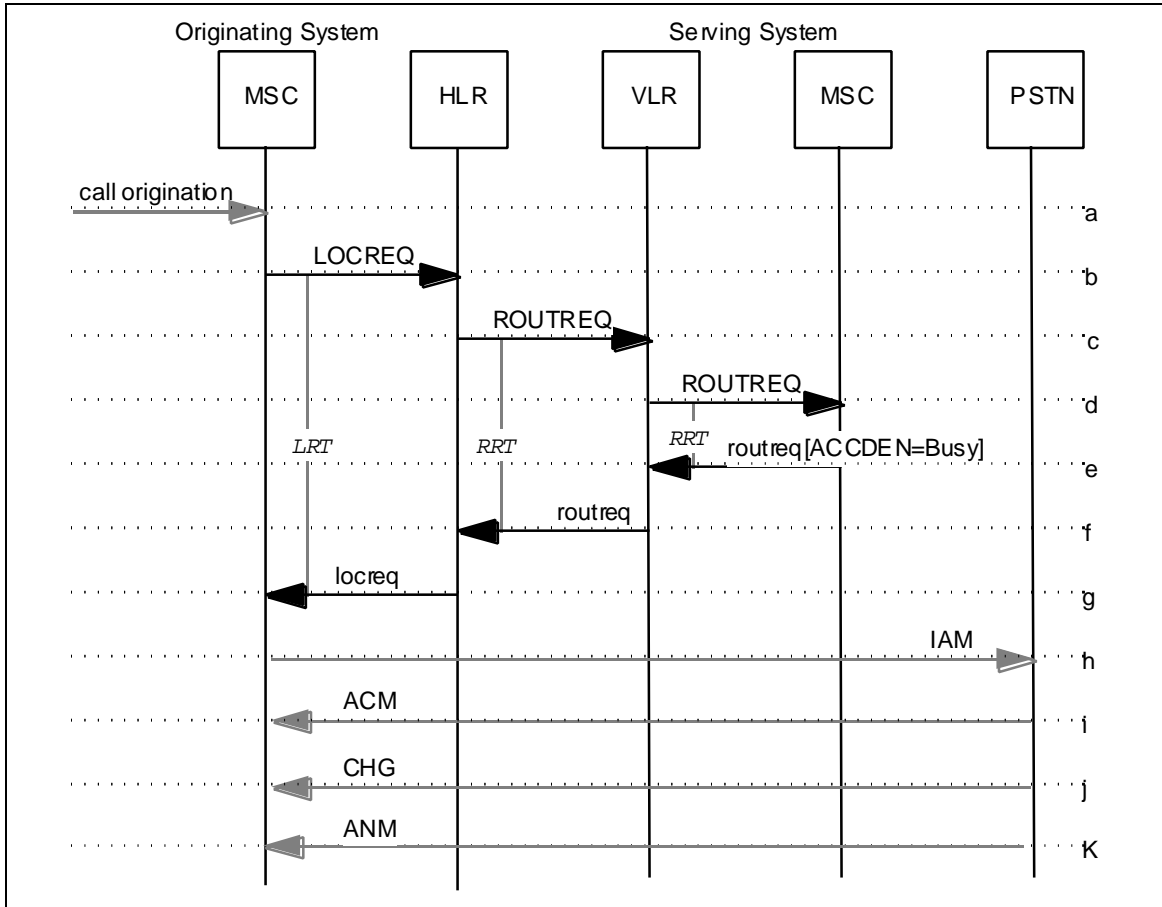

Figure J.4 CFB Invocation with Interconnection charge billing system

- a. A call origination and the dialed MS address digits (i.e., directory number) are received by the Originating MSC.
- b. The Originating MSC sends a LOCREQ to the HLR associated with the MS; this association is made through the dialed MS address digits (which may not be the MIN).
- c. If the dialed MS address digits are assigned to a legitimate subscriber, the HLR sends a ROUTREQ to the VLR where the MS is registered.
- d. The VLR then forwards the ROUTREQ to the current Serving MSC.

1
2
3
4
5
6
7
8
9
10
11
12
13
14
15
16
17
18
19
20
21
22
23
24
25
26
27
28
29
30
31
32
33
34
35
36
37
38
39
40
41
42
43
44
45
46
47
48
49
50
51
52
53
54
55
56
57
58
59
60

- e. In reaction to the ROUTREQ, the Serving MSC checks its internal data structures and determines that the MS is busy in another call. The status of the MS is returned to the VLR by the Serving MSC in the routreq. *
- f. The VLR sends the routreq to HLR. The routreq includes ChargingAreaInformation and CarrierIdentificationCode for Interconnection charge billing system. *
- g. The HLR determines from the service profile that CFB is active. It sends a locreq to the Originating MSC providing the forward-to number and other routing information in the TerminationList parameter, along with an indication of the reason for extending the incoming call (i.e., for CFB) in the DMH_RedirectionIndicator parameter. The locreq includes ChargingAreaInformation, CarrierIdentificationCode and MobileAdditionalParty'sCategory3 parameter for Interconnection charge billing system. *
- h. The Originating MSC sends an IAM (Initial Address Message) to PSTN. *
- i. PSTN returns an ACM (Address Complete Message) to the Originating MSC. *
- j. PSTN optionally sends a CHG (Charge Information Message) to the Originating MSC. *
- k. PSTN sends an ANM (Answer Message) to the Originating MSC. *

1
2
3
4
5
6
7
8
9
10
11
12
13
14
15
16
17
18
19
20
21
22
23
24
25
26
27
28
29
30
31
32
33
34
35
36
37
38
39
40
41
42
43
44
45
46
47
48
49
50
51
52
53
54
55
56
57
58
59
60

J.5. CFB Invocation with Call Collision and Interconnection charge billing system

*
*
*
*
*

This scenario describes call delivery to a MS that has CFB active and becomes engaged in a call at the same time that the Originating MSC is delivering a call to the Serving MSC with Interconnection charge billing system.

1
2
3
4
5
6
7
8
9
10
11
12
13
14
15
16
17
18
19
20
21
22
23
24
25
26
27
28
29
30
31
32
33
34
35
36
37
38
39
40
41
42
43
44
45
46
47
48
49
50
51
52
53
54
55
56
57
58
59
60

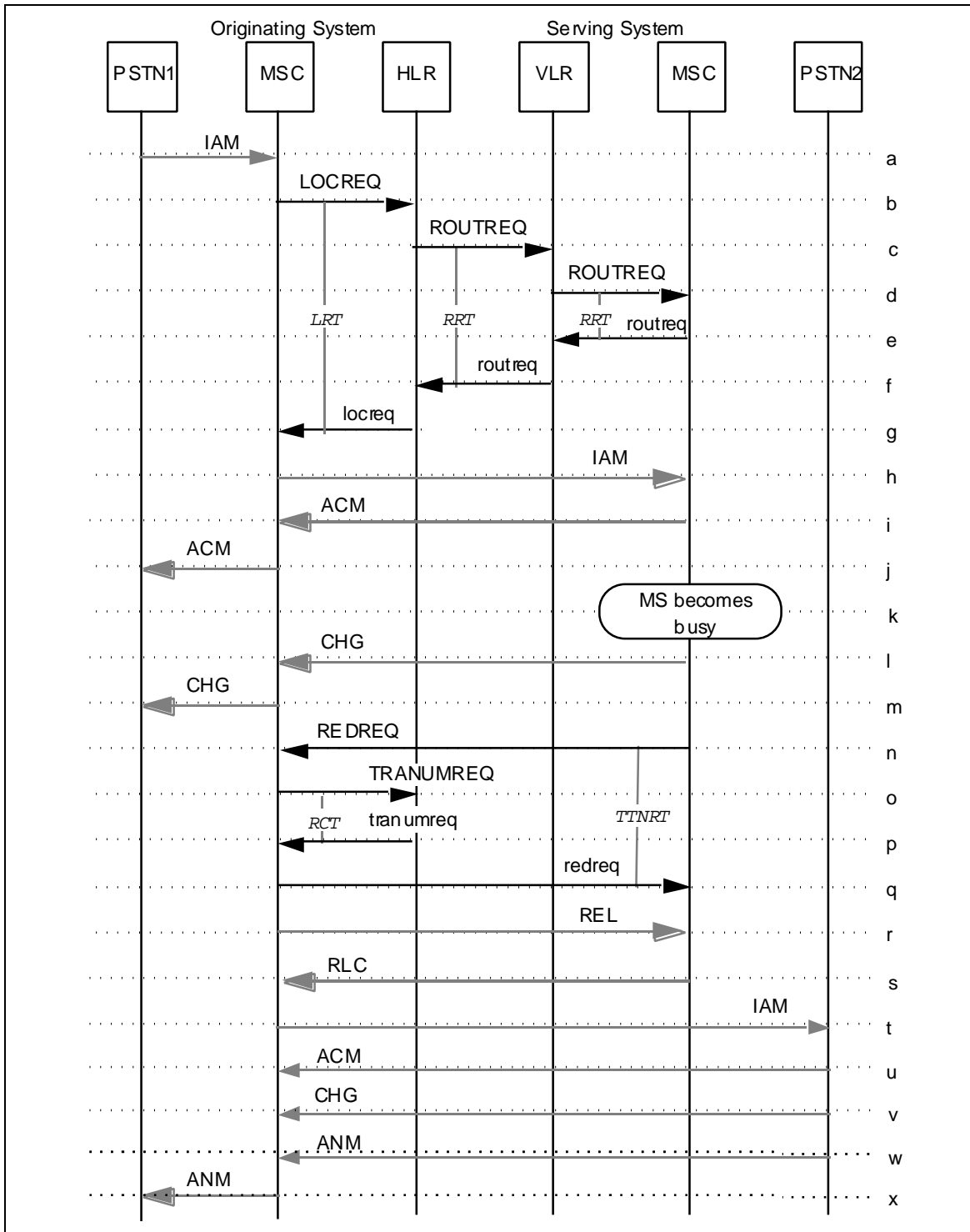

Figure J.5 CFB Invocation with Call Collision and Interconnection charge billing system *

1
2
3
4
5
6
7
8
9
10
11
12
13
14
15
16
17
18
19
20
21
22
23
24
25
26
27
28
29
30
31
32
33
34
35
36
37
38
39
40
41
42
43
44
45
46
47
48
49
50
51
52
53
54
55
56
57
58
59
60

- a. An IAM (Initial Address Message) used for call origination is received by the Originating MSC. *
- b. The Originating MSC sends a LOCREQ to the HLR associated with the MS; this association is made through the dialed MS address digits (which may not be the MIN). *
- c. If the dialed MS address digits are assigned to a legitimate subscriber, the HLR sends a ROUTREQ to the VLR where the MS is registered. *
- d. The VLR then forwards the ROUTREQ to the Serving MSC. *
- e. The Serving MSC allocates a TLDN (Temporary Local Directory Number) and returns this information to VLR in the routreq. *
- f. The VLR then forwards the routreq to HLR. The routreq includes ChargingAreaInformation and CarrierIdentificationCode parameter for Interconnection charge billing system. *
- g. When the routreq is received by the HLR, it returns a locreq to the Originating MSC. The locreq includes routing information in the form of the TerminationList parameter, along with an indication of the reason for extending the incoming call (i.e., for CD) in the DMH_RedirectionIndicator parameter. The locreq also includes ChargingAreaInformation, CarrierIdentificationCode and MobileAdditionalParty'sCategory3 parameter for Interconnection charge billing system. *
- h. The Originating MSC sends the IAM to the Serving MSC. *
- i. The Serving MSC returns an ACM (Address Complete Message) to the Originating MSC. *
- j. The Originating MSC forwards the ACM to PSTN1. *
- k. Sometime after the Serving MSC sends the routreq back to HLR, the MS becomes engaged in another call. This may be the result of an MS origination, a call through the local roamer port or the arrival of an inter-MSC call from a previous ROUTREQ. *
- l. The Serving MSC optionally sends a CHG (Charge Information Message) to the Originating MSC. *
- m. The Originating MSC optionally forwards the CHG to PSTN1. *
- n. The Serving MSC then sends a REDREQ to the Originating MSC, indicating that the call is being redirected due to a "busy" condition. The REDREQ includes ChargingAreaInformation and CarrierIdentificationCode parameter for Interconnection charge billing system. *
- o. The Originating MSC is able to redirect the call, therefore, it sends a TRANUMREQ to the HLR requesting the forward-to number appropriate for this condition from the MS's service profile. *
- p. The HLR sends the tranumreq to the Originating MSC, including the appropriate forward-to number in the TerminationList parameter, along with an indication of the reason for extending the incoming call (i.e., for CFB) in the DMH_RedirectionIndicator parameter. *

1
2
3
4
5
6
7
8
9
10
11
12
13
14
15
16
17
18
19
20
21
22
23
24
25
26
27
28
29
30
31
32
33
34
35
36
37
38
39
40
41
42
43
44
45
46
47
48
49
50
51
52
53
54
55
56
57
58
59
60

- q. When the `tr anumreq` is received from the HLR, the Originating MSC sends a `redreq` to the Serving MSC. *
- r. The Originating MSC sends a REL (Release Message) to the Serving MSC. *
- s. The Serving MSC returns a RLC (Release Complete Message) to the Originating MSC. *
- t. The Originating MSC sends the IAM to PSTN2. *
- u. PSTN2 returns the ACM to the Originating MSC. *
- v. PSTN2 optionally sends the CHG to the originating MSC. *
- w. PSTN2 sends an ANM (Answer Message) to the Originating MSC. *
- x. The Originating MSC forwards the ANM to PSTN1. *

1
2
3
4
5
6
7
8
9
10
11
12
13
14
15
16
17
18
19
20
21
22
23
24
25
26
27
28
29
30
31
32
33
34
35
36
37
38
39
40
41
42
43
44
45
46
47
48
49
50
51
52
53
54
55
56
57
58
59
60

J.6. CFNA Invocation with No Answer or No Response Page with Interconnection charge billing system

*
*
*
*

This scenario describes the interaction with Interconnection charge billing system for a CFNA invocation due to the MS not answering or a page response not being received.

1
2
3
4
5
6
7
8
9
10
11
12
13
14
15
16
17
18
19
20
21
22
23
24
25
26
27
28
29
30
31
32
33
34
35
36
37
38
39
40
41
42
43
44
45
46
47
48
49
50
51
52
53
54
55
56
57
58
59
60

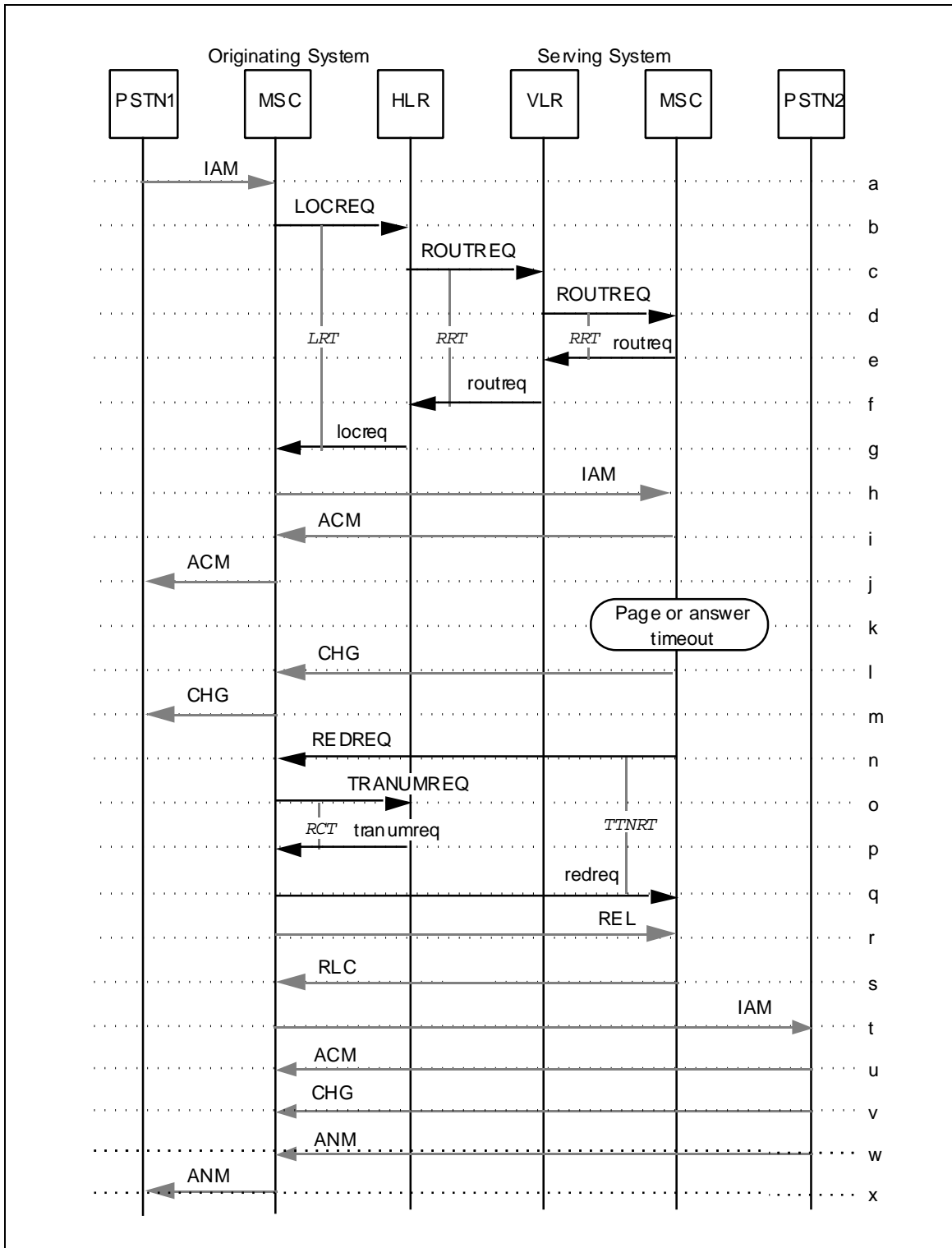

Figure J.6 CFNA Invocation with No Answer or No Response Page with Interconnection charge billing system * *

1
2
3
4
5
6
7
8
9
10
11
12
13
14
15
16
17
18
19
20
21
22
23
24
25
26
27
28
29
30
31
32
33
34
35
36
37
38
39
40
41
42
43
44
45
46
47
48
49
50
51
52
53
54
55
56
57
58
59
60

- a. An IAM (Initial Address Message) used for call origination is received by the Originating MSC. *
- b. The Originating MSC sends a LOCREQ to the HLR associated with the MS; this association is made through the dialed MS address digits (which may not be the MIN). *
- c. If the dialed MS address digits are assigned to a legitimate subscriber, the HLR sends a ROUTREQ to the VLR where the MS is registered. *
- d. The VLR then forwards the ROUTREQ to the Serving MSC. *
- e. The Serving MSC allocates a TLDN (Temporary Local Directory Number) and returns this information to VLR in the routreq. *
- f. The VLR then forwards the routreq to HLR. The routreq includes ChargingAreaInformation and CarrierIdentificationCode parameter for Interconnection charge billing system. *
- g. When the routreq is received by the HLR, it returns a locreq to the Originating MSC. The locreq includes routing information in the form of the TerminationList parameter, along with an indication of the reason for extending the incoming call (i.e., for CD) in the DMH_RedirectionIndicator parameter. The also locreq includes ChargingAreaInformation, CarrierIdentificationCode and MobileAdditionalPartCategory3 parameter for Interconnection charge billing system. *
- h. The Originating MSC sends the IAM to the Serving MSC. *
- i. The Serving MSC returns an ACM (Access Complete Message) to the Originating MSC. *
- j. The Originating MSC forwards the ACM to PSTN1. *
- k. When the inter-MS-C call is received at the Serving MSC, the MS is paged and, if a page response is received, subsequently alerted. If the MS fails to respond to the page or does not answer after alerting, the Serving MSC determines from the service profile that the MS has call forwarding active on no answer or no response to page conditions. *
- l. The Serving MSC optionally sends a CHG (Charge Information Message) to the Originating MSC. *
- m. The Originating MSC optionally forwards the CHG to PSTN1. *
- n. The Serving MSC sends the REDREQ to the Originating MSC, indicating that the call is being redirected due to a no answer or no page response condition. The REDREQ includes ChargingAreaInformation and CarrierIdentificationCode parameter for Interconnection charge billing system. *
- o. The Originating MSC is able to redirect the call, therefore, it sends a TRANUMREQ to the HLR requesting the forward-to number appropriate for this condition from the MS's service profile. *
- p. The HLR sends the tranumreq to the Originating MSC, including the appropriate forward-to number in the TerminationList parameter, along with an indication of the reason for extending the incoming call (i.e., for CFNA) in the DMH_RedirectionIndicator parameter. *

1
2
3
4
5
6
7
8
9
10
11
12
13
14
15
16
17
18
19
20
21
22
23
24
25
26
27
28
29
30
31
32
33
34
35
36
37
38
39
40
41
42
43
44
45
46
47
48
49
50
51
52
53
54
55
56
57
58
59
60

- q. When the `tr anumreq` is received from the HLR, the Originating MSC sends a `redreq` to the Serving MSC. *
- r. The Originating MSC sends a REL (Release Message) to the Serving MSC to release voice path. *
- s. The Serving MSC returns a RLC (Release Complete Message) to the Originating MSC. *
- t. The Originating MSC sends the IAM to PSTN2. *
- u. PSTN2 returns an ACM (Address Complete Message) to the Originating MSC. *
- v. PSTN2 optionally sends a CHG (Charge Information Message) to the originating MSC. *
- w. PSTN2 sends an ANM (Answer Message) to the Originating MSC. *
- x. The Originating MSC forwards the ANM to PSTN1. *

J.7. CFU Invocation with Interconnection charge billing system

This scenario describes CFU invocation to the served MS with Interconnection charge billing system.

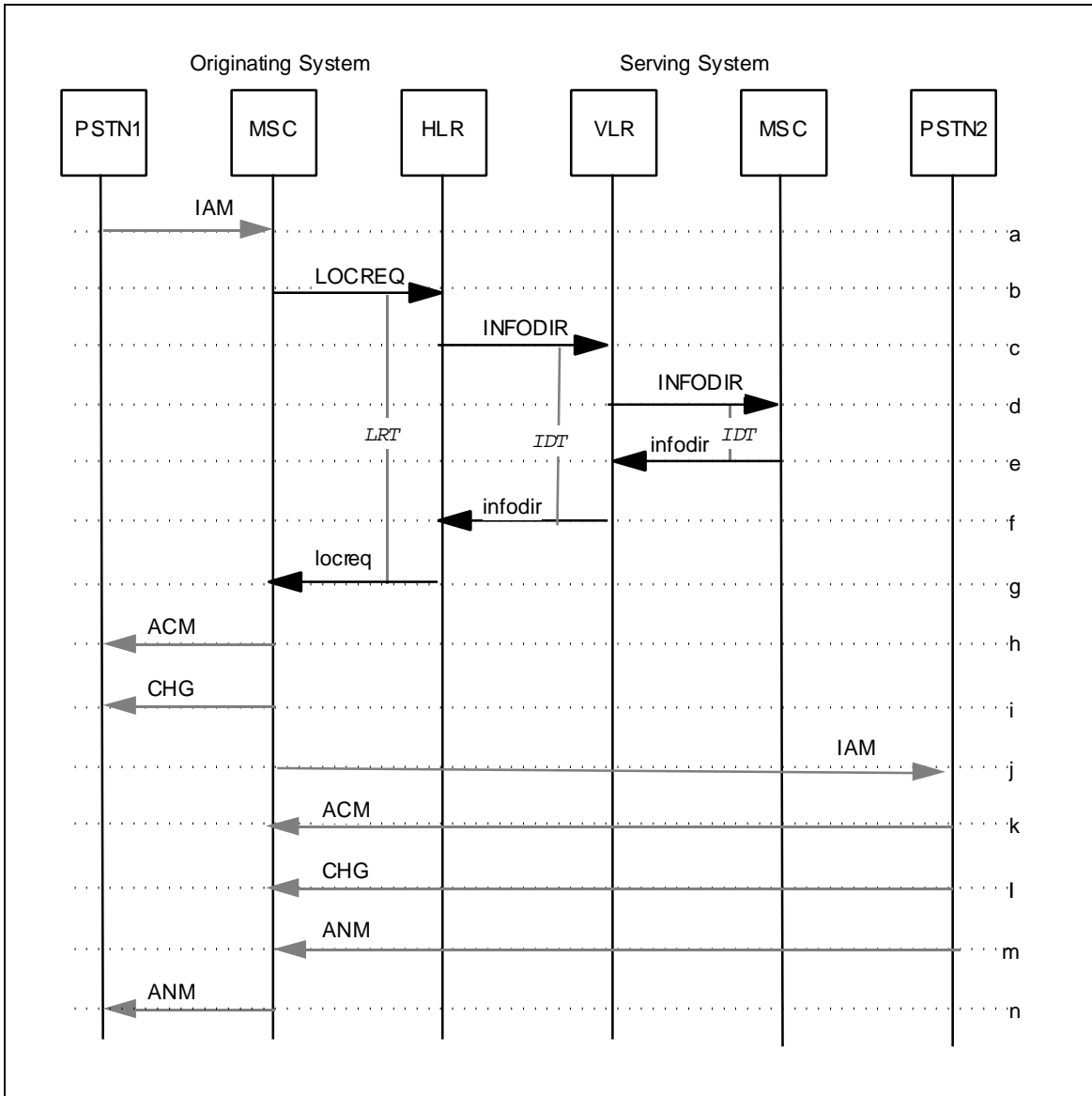

Figure J.7 CFU Invocation with Interconnection charge billing system

- a. An IAM (Initial Address Message) used for call origination is received by the Originating MSC.
- b. The Originating MSC sends the LOCREQ to the HLR associated with the MS; this association is made through the dialed MS address digits (which may not be the MIN).

1
2
3
4
5
6
7
8
9
10
11
12
13
14
15
16
17
18
19
20
21
22
23
24
25
26
27
28
29
30
31
32
33
34
35
36
37
38
39
40
41
42
43
44
45
46
47
48
49
50
51
52
53
54
55
56
57
58
59
60

- c. The HLR determines from the MS's service profile that CFU is active. It sends the `INFODIR` to the VLR to get the latest MS's information like `ChargingAreaInformation` and `CarrierIdentificationCode` parameter for Interconnection charge billing system. *
- d. The VLR then forwards the `INFODIR` to the current Serving MSC. *
- e. The Serving MSC sends the `infodir` to the VLR. *
- f. The VLR sends the `infodir` to the HLR. The `infodir` includes `ChargingAreaInformation` and `CarrierIdentificationCode` parameter for Interconnection charge billing system. *
- g. When the `infodir` is received by the HLR, it returns a `locreq` to the originating MSC. The `locreq` includes `ChargingAreaInformation`, `CarrierIdentificationCode` and `MobileAdditionalParty'sCategory3` parameter for Interconnection charge billing system. *
- h. The originating MSC sends an ACM (Address Complete Message) to PSTN1. *
- i. The originating MSC optionally sends a CHG (Charge Information Message) to PSTN1. *
- j. The originating MSC sends an IAM to PSTN2. *
- k. PSTN2 returns an ACM to the originating MSC. *
- l. PSTN2 optionally sends a CHG to the originating MSC. *
- m. PSTN2 sends an ANM (Answer Message) to the originating MSC. *
- n. The originating MSC forwards the ANM to PSTN1. *

CELLULAR RADIOTELECOMMUNICATIONS INTERSYSTEM OPERATIONS:
CHAPTER 4
OPERATIONS, ADMINISTRATION, AND MAINTENANCE
INFORMATION FLOWS AND PROCEDURES

1
2
3
4
5
6
7
8
9
10
11
12
13
14
15
16
17
18
19
20
21
22
23
24
25
26
27
28
29
30
31
32
33
34
35
36
37
38
39
40
41
42
43
44
45
46
47
48
49
50
51
52
53
54
55
56
57
58
59
60

CONTENTS

FOREWORD v

REVISION HISTORYvi

1. INTRODUCTION 1

 1.1 OBJECTIVE.....1

 1.2 SCOPE1

 1.3 ORGANIZATION1

2. REFERENCES..... 1

3. TERMINOLOGY2

 3.1. DEFINITIONS2

 3.2. SYMBOLS AND ABBREVIATIONS2

 3.3. DOCUMENTATION CONVENTIONS.....2

4. INTERSYSTEM OA&M OPERATIONS3

 4.1. Blocking.....4

 4.1.1. Normal Operation.....4

 4.2. Unblocking.....5

 4.2.1. Normal Operation.....5

 4.3. ResetCircuit.....6

 4.3.1. Normal Operation.....6

 4.4. TrunkTest7

 4.4.1. Normal Operation.....7

 4.5. TrunkTestDisconnect8

 4.5.1. Normal Operation.....8

5. OA&M MESSAGE PROCEDURES FOR HANDOFF.....9

 5.1 NETWORK FEATURES9

 5.1.1 Automatic Repeat Attempt9

 5.1.2 Blocking and Unblocking of Circuits9

 5.1.3 Blocking States10

 5.1.4 State Transitions.....10

 5.1.5 Other Actions on Receipt of a Blocking INVOKE.....13

 5.1.6 State Transition Table.....13

 5.2 ABNORMAL CONDITIONS20

 5.2.1 Dual Seizure (glare)20

5.2.1.1	Unguarded Interval.....	20	1
5.2.1.2	Detection of Dual Seizure.....	20	2
5.2.1.3	Preventative Action for Dual Seizure.....	20	3
5.2.1.4	Action To Be Taken On Detection Of Dual Seizure	20	4
5.2.2	Reset of Circuits.....	21	5
5.2.2.1	Reset Circuit Signal.....	21	6
5.2.3	Failure in the Blocking and Unblocking Sequences	22	7
5.2.4	Receipt Of Unreasonable Signaling Information	23	8
5.2.5	Loss of Messages in the Release Sequence.....	24	9
5.2.5.1	Failure to Receive a FacilitiesRelease RETURN RESULT	24	10
5.2.6	Other Failure Conditions	24	11
5.2.6.1	Inability to Release in Response to a FacilitiesRelease INVOKE.....	24	12
5.3	OA&M TIMER VALUES FOR HANDOFF CIRCUITS	24	13
6.	INTERMSC TRUNK TESTING.....	25	14
6.1	INTRODUCTION	25	15
6.2	TEST DESCRIPTION	25	16
6.3	TEST PROCEDURES	26	17
6.3.1	Trunk Test Request	26	18
6.3.2	Trunk Test Reply.....	27	19
6.3.3	Trunk Test Disconnect Request	27	20
6.3.4	Trunk Test Disconnect Reply.....	27	21
6.4	OA&M TIMER VALUES FOR TRUNK TESTING	28	22
7.	ISSUES FOR FURTHER STUDY	28	23
			24
			25
			26
			27
			28
			29
			30
			31
			32
			33
			34
			35
			36
			37
			38
			39
			40
			41
			42
			43
			44
			45
			46
			47
			48
			49
			50
			51
			52
			53
			54
			55
			56
			57
			58
			59
			60

1
2
3
4
5
6
7
8
9
10
11
12
13
14
15
16
17
18
19
20
21
22
23
24
25
26
27
28
29
30
31
32
33
34
35
36
37
38
39
40
41
42
43
44
45
46
47
48
49
50
51
52
53
54
55
56
57
58
59
60

LIST OF FIGURES

Figure 1	Normal Operation (Blocking)	4
Figure 2	Normal Operation (Unblocking)	5
Figure 3	Normal Operation (ResetCircuit)	6
Figure 4	Normal Operation (TrunkTest)	7
Figure 5	Normal Operation (TrunkTestDisconnect)	8
Figure 6	InterMSC Transmission Diagram.....	26
Figure 7	InterMSC Noise Diagram	26

LIST OF TABLES

Table 1	Operation Component and Timer Acronyms	2
Table 2	FE Combinations for Blocking.....	4
Table 3	FE Combinations for Unblocking.....	5
Table 4	FE Combinations for ResetCircuit	6
Table 5	FE Combinations for TrunkTest.....	7
Table 6	FE Combinations for TrunkTestDisconnect.....	8
Table 7	Blocking States.....	10
Table 8	State Transition After Message Received	15
Table 9	State Transition After Message Transmitted	18
Table 10	Handoff OA&M Timer Values	24
Table 11	Trunk Test Timer Values	28

1
2
3
4
5
6
7
8
9
10
11
12
13
14
15
16
17
18
19
20
21
22
23
24
25
26
27
28
29
30
31
32
33
34
35
36
37
38
39
40
41
42
43
44
45
46
47
48
49
50
51
52
53
54
55
56
57
58
59
60

FOREWORD

This foreword is not part of this Standard.

This is the fourth part in a series of recommendations entitled:

“Cellular Radiotelecommunications Intersystem Operations”

which describe procedures necessary to provide to cellular radio telephone subscribers certain services requiring interaction between different cellular systems.

It is the intention of TIA/EIA TR-45.2 Subcommittee, Intersystem Operations, that this series of recommendations address the ongoing and developing concerns of the Cellular Radiotelecommunications Industry—subscribers, service providers and manufacturers alike—with regard to useful and effective services requiring standardized intersystem procedures.

The recommendations included in this series are:

- Chapter 1, *Cellular Radiotelecommunications Intersystem Operations: Functional Overview*
- Chapter 2, *Cellular Radiotelecommunications Intersystem Operations: Intersystem Handoff Information Flows*
- Chapter 3, *Cellular Radiotelecommunications Intersystem Operations: Automatic Roaming Information Flows*
- Chapter 4, *Cellular Radiotelecommunications Intersystem Operations: Operations, Administration, and Maintenance Information Flows and Procedures*
- Chapter 5, *Cellular Radiotelecommunications Intersystem Operations: Signaling Protocols*
- Chapter 6, *Cellular Radiotelecommunications Intersystem Operations: Signaling Procedures*

This edition of the Standard replaces *IS-41-C* which differs from the previous edition (i.e., *IS-41-B*) in its support of the following functionality:

- Intersystem Authentication and Encryption (supersedes *TSB51*)
- Intersystem Operations for Dual-mode CDMA Terminals (supersedes *TSB64*)
- Border Cell Problem Resolution (supersedes *TSB65*)
- Expanded Feature Support (i.e., for features defined in *TIA/EIA-664*)
- Technical Clarifications and Compatibility (as per *TSB41* and *TSB55*)

REVISION HISTORY

Revision	Date	Remarks
<i>(IS-41)0</i>	February 1988	Initial publication
<i>(IS-41)A</i>	January 1991	
<i>(IS-41)B</i>	December 1991	
<i>(IS-41)C</i>	February 1996	
D	December 1997	Initial ANSI publication

NOTE

The numbering system of this series of Standards varies from normal TIA/EIA practice. The unique numbering system assigned to these documents is intended to reflect their hierarchical structure.

1
2
3
4
5
6
7
8
9
10
11
12
13
14
15
16
17
18
19
20
21
22
23
24
25
26
27
28
29
30
31
32
33
34
35
36
37
38
39
40
41
42
43
44
45
46
47
48
49
50
51
52
53
54
55
56
57
58
59
60

1. INTRODUCTION

1.1 OBJECTIVE

The objective of this document is to provide a definition of the information flows and procedures which permit cellular operators to perform trunk maintenance between dissimilar systems.

1.2 SCOPE

This document defines the intersystem Operations, Administration, and Maintenance (OA&M) information flows and procedures required for intersystem trunk maintenance.

Rather than taking an abstract approach, this document uses the information flows captured in the messages, parameters, and procedures defined in *IS-41-B* as its starting point. Where necessary, additional information flows are specified in order to meet the requirements associated with the support of the features in *TIA/EIA-664*.

The detailed encoding of the signaling messages and parameters which are derived from the information flows in this document are specified in Chapter 5.

1.3 ORGANIZATION

This document is organized as follows:

- Section 1, entitled “Introduction,” provides introductory information for this Standard.
- Section 2, entitled “References,” lists the normative and informative references for this Standard.
- Section 3, entitled “Terminology,” lists the definitions, symbols, abbreviations, and other documentation conventions used in this Standard.
- Section 4, entitled “Intersystem OA&M Operations,” defines the set of *TIA/EIA-41* intersystem OA&M operations in terms of the interactions between network functional entities (FEs) involved in the support of the operations’ capabilities.
- Section 5, entitled “OA&M Message Procedures for Handoff,” describes the sequence of events and messages which occur during OA&M operations.
- Section 6, entitled “InterMSC Trunk Testing,” describes a method to verify the continuity of audio path trunks between MSCs.
- Section 7 provides a list of issues that require further study.

2. REFERENCES

Refer to Chapter 1.

3. TERMINOLOGY

3.1. DEFINITIONS

Refer to Chapter 1.

3.2. SYMBOLS AND ABBREVIATIONS

Refer to Chapter 1.

Throughout this Standard, the operation component acronyms listed in the following table are used. The acronyms for the operation timers (i.e., the timer that runs between the sending of an operation INVOKE component and the receipt of the operation response) are also listed.

Table 1 Operation Component and Timer Acronyms

Operation Name	INVOKE Component Acronym	RETURN RESULT Component Acronym	Operation Timer Acronym
Blocking	BLOCKING	blocking	BLKT
Unblocking	UNBLOCKING	unblocking	UBLKT
ResetCircuit	RESETCKT	resetckt	RSTT
TrunkTest	TTEST	ttest	TTT
TrunkTestDisconnect	TTESTDISC	ttestdisc	TTDT

3.3. DOCUMENTATION CONVENTIONS

Refer to Chapter 1.

1
2
3
4
5
6
7
8
9
10
11
12
13
14
15
16
17
18
19
20
21
22
23
24
25
26
27
28
29
30
31
32
33
34
35
36
37
38
39
40
41
42
43
44
45
46
47
48
49
50
51
52
53
54
55
56
57
58
59
60

4. INTERSYSTEM OA M OPERATIONS

This section defines the *TIA/EIA-41* OA&M operations in terms of the interactions between network Functional Entities (FEs) involved in the support of the operations' capabilities. Refer to Section 3.2 for a listing of the operation component acronyms used in this section.

The operation usage scenarios shown throughout this section are for illustrative purposes only.

4.1. Blocking

The Blocking operation is used to inform an MSC of the removal from service of a designated circuit.

The following table lists the possible combinations of invoking and responding FEs.

Table 2 FE Combinations for Blocking

	INVOKING FE	RESPONDING FE
Case 1	MSC	MSC

4.1.1. Normal Operation

This scenario describes the normal use of the Blocking operation.

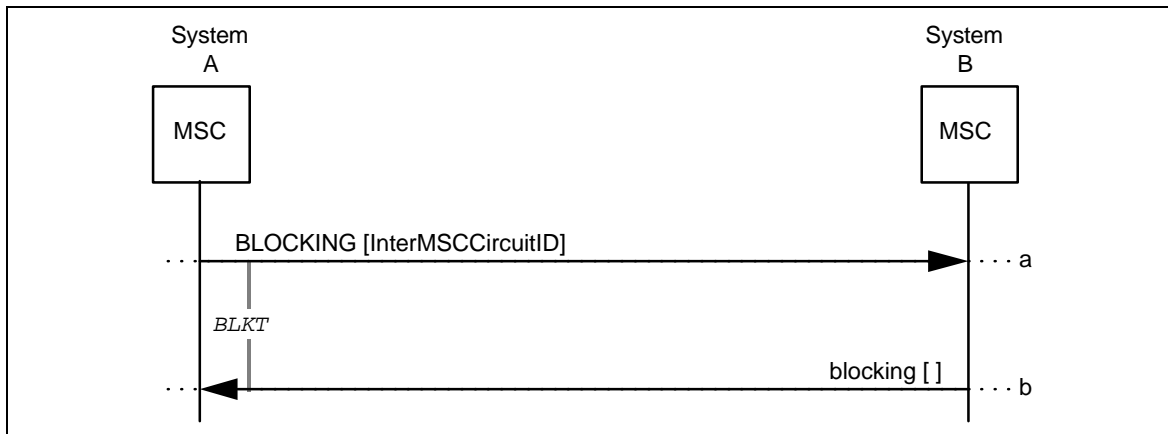

Figure 1 Normal Operation (Blocking)

- a. MSC-A sends a BLOCKING to MSC-B, directing MSC-B to remove from service the circuit identified by the InterMSCCircuitID parameter.

Parameters	Usage	Type
InterMSCCircuitID	Specifies the trunk in a dedicated trunk group between the two MSCs to be removed from service.	R

- b. On receipt of the BLOCKING, MSC-B may adjust the state for outgoing calls on the designated circuit as described in Section 5.1.2; the ability to receive incoming calls on the designated circuit is not affected. MSC-B then acknowledges receipt of the BLOCKING by sending a blocking to MSC-A.

1
2
3
4
5
6
7
8
9
10
11
12
13
14
15
16
17
18
19
20
21
22
23
24
25
26
27
28
29
30
31
32
33
34
35
36
37
38
39
40
41
42
43
44
45
46
47
48
49
50
51
52
53
54
55
56
57
58
59
60

4.2. Unblocking

The Unblocking operation is used to inform an MSC of the reinsertion into service of a certain circuit.

The following table lists the possible combinations of invoking and responding FEs.

Table 3 FE Combinations for Unblocking

	INVOKING FE	RESPONDING FE
Case 1	MSC	MSC

4.2.1. Normal Operation

This scenario describes the normal use of the Unblocking operation.

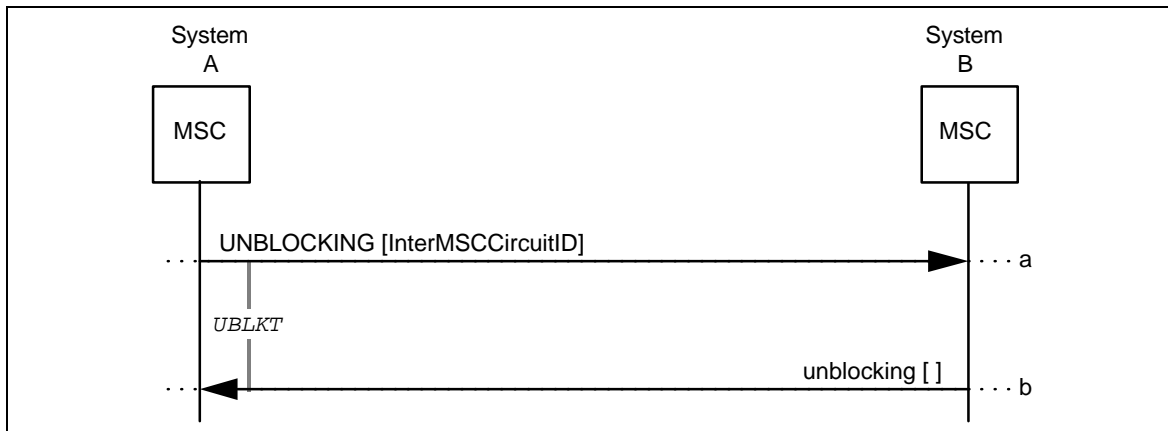

Figure 2 Normal Operation (Unblocking)

- a. MSC-A sends an UNBLOCKING to MSC-B, directing MSC-B to return to service the circuit identified by the InterMSCCircuitID parameter.

Parameters	Usage	Type
InterMSCCircuitID	Specifies the trunk in a dedicated trunk group between the two MSCs to be reinserted into service.	R

- b. On receipt of the UNBLOCKING, MSC-B may adjust the state for outgoing calls on the designated circuit as described in Section 5.1.2; the ability to receive incoming calls on the designated circuit is not affected. MSC-B then acknowledges receipt of the UNBLOCKING by sending an unblocking to MSC-A.

4.3. ResetCircuit

The ResetCircuit operation (RESETCKT) is used by an MSC to restore information about circuit conditions which has been lost due to, for example, a restart. It may also be used when placing circuits into service.

The following table lists the possible combinations of invoking and responding FEs.

Table 4 FE Combinations for ResetCircuit

	INVOKING FE	RESPONDING FE
Case 1	MSC	MSC

4.3.1. Normal Operation

This scenario describes the normal use of the ResetCircuit operation.

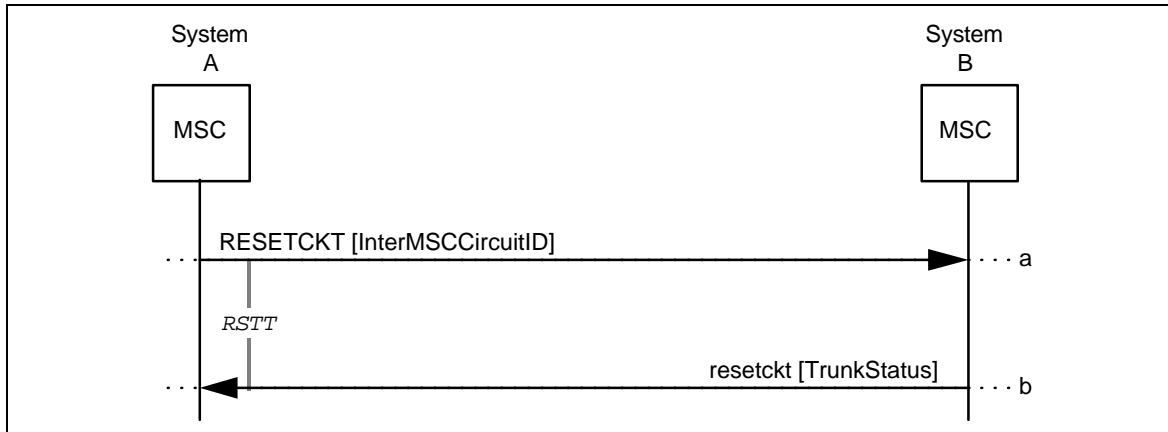

Figure 3 Normal Operation (ResetCircuit)

- a. MSC-A sends a RESETCKT to MSC-B, directing MSC-B to reset to the idle condition the circuit identified by the InterMSCCircuitID parameter.

Parameters	Usage	Type
InterMSCCircuitID	Specifies the trunk in a dedicated trunk group between the two MSCs to be reinserted into service.	R

- b. On receipt of the RESETCKT, MSC-B may adjust the state of the designated circuit as described in Section 5.2.2. MSC-B then returns the trunk status and acknowledges receipt of the RESETCKT by sending a resetckt to MSC-A.

Parameters	Usage	Type
TrunkStatus	Status of specified trunk = {idle blocked}.	R

1
2
3
4
5
6
7
8
9
10
11
12
13
14
15
16
17
18
19
20
21
22
23
24
25
26
27
28
29
30
31
32
33
34
35
36
37
38
39
40
41
42
43
44
45
46
47
48
49
50
51
52
53
54
55
56
57
58
59
60

4.4. TrunkTest

The TrunkTest (TTEST) operation is used by an MSC to request that the designated trunk be configured for automatic test (e.g., loop-back) at a remote MSC.

The following table lists the possible combinations of invoking and responding FEs.

Table 5FE Combinations for TrunkTest

	INVOKING FE	RESPONDING FE
Case 1	MSC	MSC

4.4.1. Normal Operation

This scenario describes the normal use of the TrunkTest operation.

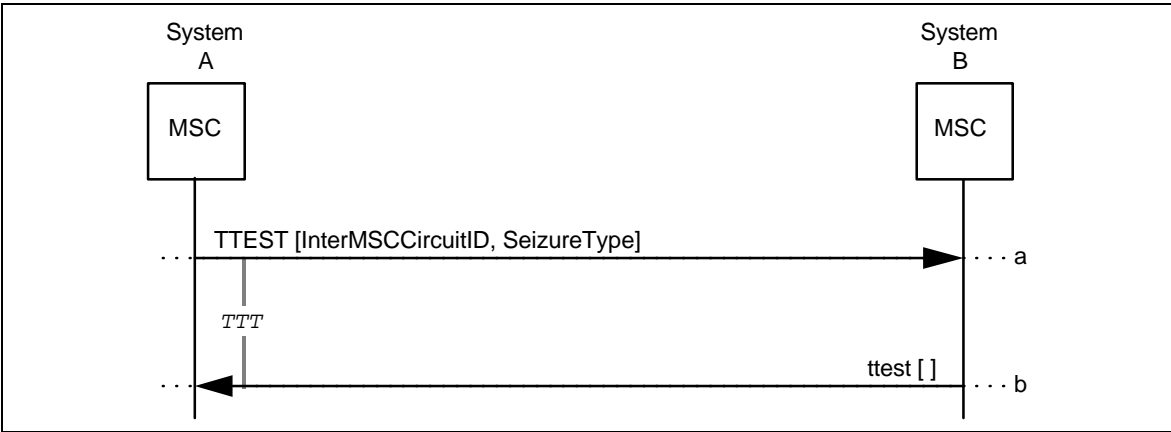

Figure 4 Normal Operation (TrunkTest)

- a. MSC-A sends a TTEST to MSC-B, requesting MSC-B to loop back the circuit identified by the InterMSCCircuitID parameter.

Parameters	Usage	Type
InterMSCCircuitID	Specifies the trunk in a dedicated trunk group between the two MSCs to be looped back.	R
SeizureType	Type of trunk seizure = loop back.	R

- b. On receipt of the TTEST, MSC-B determines if the test call will be accepted using its internal algorithms. If it is accepted, MSC-B activates the loop back and acknowledges receipt of the TTEST by sending a ttest to MSC-A.

4.5. TrunkTestDisconnect

The TrunkTestDisconnect (TTESTDISC) operation is used by an MSC to request configuration for an automatic test (e.g. loop-back) of the designated trunk at a remote MSC be disconnected.

The following table lists the possible combinations of invoking and responding FEs.

Table 6 FE Combinations for TrunkTestDisconnect

	INVOKING FE	RESPONDING FE
Case 1	MSC	MSC

4.5.1. Normal Operation

This scenario describes the normal use of the TrunkTestDisconnect operation.

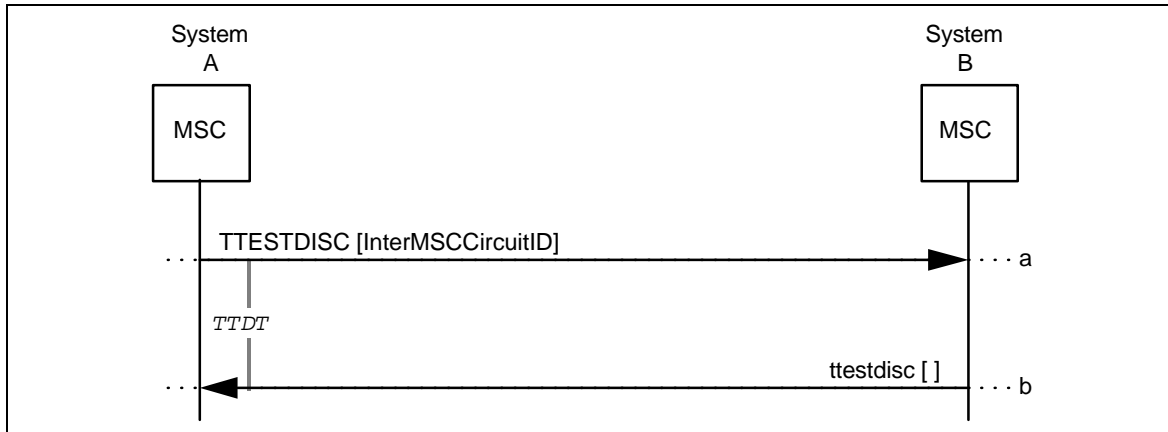

Figure 5 Normal Operation (TrunkTestDisconnect)

- a. MSC-A sends a TTESTDISC to MSC-B, requesting MSC-B to disconnect the loop back of the circuit identified by the InterMSCCircuitID parameter.

Parameters	Usage	Type
InterMSCCircuitID	Specifies the trunk in a dedicated trunk group between the two MSCs which is to have loop-back disconnected.	R

- b. On receipt of the TTESTDISC, MSC-B returns the trunk to its pre-test state and acknowledges receipt of the TTESTDISC by sending a ttestdisc to MSC-A.

1
2
3
4
5
6
7
8
9
10
11
12
13
14
15
16
17
18
19
20
21
22
23
24
25
26
27
28
29
30
31
32
33
34
35
36
37
38
39
40
41
42
43
44
45
46
47
48
49
50
51
52
53
54
55
56
57
58
59
60

5. OA M MESSAGE PROCEDURES FOR HANDOFF

5.1 NETWORK FEATURES

5.1.1 Automatic Repeat Attempt

An automatic repeat attempt shall be made:

- 1) on detection of dual seizure (at the non-control MSC);
- 2) on receipt of the Blocking INVOKE after sending a FacilitiesDirective INVOKE and before any backward message has been received;
- 3) on receipt of a ResetCircuit INVOKE after sending a FacilitiesDirective INVOKE and before any backward message has been received.

5.1.2 Blocking and Unblocking of Circuits

The Blocking (Unblocking) INVOKE is provided to permit the switching equipment maintenance personnel to remove from (and return to) traffic the distant terminal of a circuit because of fault or to permit testing.

The Blocking INVOKE can be originated by either MSC, since the circuits have bi-directional capability. The receipt of a Blocking INVOKE shall have the effect of prohibiting calls on the relevant circuit outgoing from the MSC until an Unblocking INVOKE is received, but shall not prohibit calls incoming to that MSC. Furthermore, receipt of a Blocking or Unblocking INVOKE shall not disrupt a handoff or trunk test that is already established on the circuit. Acknowledgment sequences are always required for the Blocking and Unblocking INVOKEs using the Blocking RETURN RESULT and the Unblocking RETURN RESULT, respectively. The RETURN RESULT is not sent until the appropriate action, either Blocking or Unblocking has been taken. The FacilitiesRelease INVOKE should not override the Blocking INVOKE and return circuits to service which might be faulty. The blocked circuit shall be returned to service on transmission of the Unblocking RETURN RESULT at one MSC and on receipt of the Unblocking RETURN RESULT at the other MSC.

5.1.3 Blocking States

Table 7 Blocking States

Blocking State	Symbol	Meaning
A	ACT	indicating that the circuit can be used for handoffs by the Near MSC or the Far MSC.
	RB	indicating that the Near MSC has received a request from the Far MSC to not initiate handoffs on that circuit.
	LB	indicating that the Near MSC has requested the Far MSC to not initiate handoffs on that circuit.
	LRB	indicating that the circuit cannot be used for handoffs by the Near MSC or the Far MSC.

NOTE: Either MSC can initiate a trunk test in any of the above states. Blocking does not affect trunk tests. Also, an MSC can send a FacilitiesDirective INVOKE or an InterSystemSetup INVOKE for a circuit in the *Locally Blocked* state, but both the Near MSC (which is *Locally Blocked*) and Far MSC (which is *Remotely Blocked*) should change the blocking state of the relevant circuit to *Active*.

5.1.4 State Transitions

- 1) If an MSC has a circuit in the state *Active*, then:¹
 - a) Sending a Blocking INVOKE for the circuit causes a state change to *Locally Blocked*.
 - b) Receiving a Blocking INVOKE for the circuit causes a state change to *Remotely Blocked*. (A Blocking RETURN RESULT should also be sent back.)
 - c) Receiving a Blocking RETURN RESULT for the circuit is not valid.
 - d) Sending an Unblocking INVOKE for the circuit causes no state change.
 - e) Receiving an Unblocking INVOKE for the circuit causes no state change. (An Unblocking RETURN RESULT should also be sent back.)
 - f) Receiving an Unblocking RETURN RESULT for the circuit causes no state change.
 - g) Sending a ResetCircuit INVOKE for the circuit causes no state change.
 - h) Receiving a ResetCircuit INVOKE for the circuit causes no state change. (A ResetCircuit RETURN RESULT should also be sent back with a trunk status of idle.)
 - i) Sending a ResetCircuit RETURN RESULT with a trunk status of blocked is not allowed in the state *Active*.
 - j) Receiving a ResetCircuit RETURN RESULT with a trunk status of blocked causes a state change to *Remotely Blocked*.
 - k) Receiving a ResetCircuit RETURN RESULT with a trunk status of idle causes no state change.

¹See 5.1.6.

- 1) Sending a FacilitiesDirective INVOKE for the circuit causes no state change.
- m) Receiving a FacilitiesDirective INVOKE for the circuit causes no state change. (A FacilitiesDirective RETURN RESULT should also be sent back.)
- n) Receiving a FacilitiesDirective RETURN RESULT for the circuit causes no state change.
- o) Sending an InterSystemSetup INVOKE for the circuit causes no state change.
- p) Receiving an InterSystemSetup INVOKE for the circuit causes no state change. (An InterSystemSetup RETURN RESULT should also be sent back.)
- q) Receiving an InterSystemSetup RETURN RESULT for the circuit causes no state change.
- 2) If an MSC has a circuit in the state *Remotely Blocked*, then :
- a) Sending a Blocking INVOKE for the circuit causes a state change to *Locally and Remotely Blocked*.
- b) Receiving a Blocking INVOKE for the circuit causes no state change. (A Blocking RETURN RESULT should also be sent back.)
- c) Receiving a Blocking RETURN RESULT for the circuit is not valid.
- d) Sending an Unblocking INVOKE for the circuit causes no state change.
- e) Receiving an Unblocking INVOKE for the circuit causes a state change to *Active*. (An Unblocking RETURN RESULT should also be sent back.)
- f) Receiving an Unblocking RETURN RESULT for the circuit causes no state change.
- g) Sending a ResetCircuit INVOKE for the circuit causes no state change.
- h) Receiving a ResetCircuit INVOKE for the circuit causes a state change to *Active*. (A ResetCircuit RETURN RESULT should also be sent back with a trunk status of idle.)
- i) Sending a ResetCircuit RETURN RESULT with a trunk status of blocked is not allowed in the state *Remotely Blocked*.
- j) Receiving a ResetCircuit RETURN RESULT with a trunk status of blocked causes no state change.
- k) Receiving a ResetCircuit RETURN RESULT with a trunk status of idle causes a state change to *Active*.
- l) Sending a FacilitiesDirective INVOKE for the circuit is not allowed.
- m) Receiving a FacilitiesDirective INVOKE for the circuit causes a state change to *Active*. (A FacilitiesDirective RETURN RESULT should also be sent back.)
- n) Receiving a FacilitiesDirective RETURN RESULT for the circuit is not valid.
- o) Sending an InterSystemSetup INVOKE for the circuit is not allowed.
- p) Receiving an InterSystemSetup INVOKE for the circuit causes a state change to *Active*. (An InterSystemSetup RETURN RESULT should also be sent back.)
- q) Receiving an InterSystemSetup RETURN RESULT for the circuit is not valid.
- 3) If an MSC has a circuit in the state *Locally Blocked*, then :
- a) Sending a Blocking INVOKE for the circuit causes no state change.
- b) Receiving a Blocking INVOKE for the circuit causes a state change to *Locally and Remotely Blocked*. (A Blocking RETURN RESULT should also be sent back.)
- c) Receiving a Blocking RETURN RESULT for the circuit causes no state change.
- d) Sending an Unblocking INVOKE for the circuit causes a state change to *Active*.

- e) Receiving an Unblocking INVOKE for the circuit causes no state change. (An Unblocking RETURN RESULT should also be sent back.) 1
2
- f) Receiving an Unblocking RETURN RESULT for the circuit is not valid. 3
4
- g) Sending a ResetCircuit INVOKE for the circuit causes a state change to *Active*. 5
6
- h) Receiving a ResetCircuit INVOKE for the circuit causes no state change. (A ResetCircuit RETURN RESULT with a trunk status of blocked should also be sent back.) 7
8
9
- i) Sending a ResetCircuit RETURN RESULT with a trunk status of idle is not allowed in *Locally Blocked*. 10
11
- j) Receiving a ResetCircuit RETURN RESULT for the circuit is not valid. 12
- k) Sending a FacilitiesDirective INVOKE for the circuit causes a state change to *Active*. 13
14
15
- l) Receiving a FacilitiesDirective INVOKE for the circuit causes no state change. (A FacilitiesDirective RETURN ERROR should also be sent back.) 16
17
18
- m) Receiving a FacilitiesDirective RETURN RESULT for the circuit is not valid. 19
- n) Sending an InterSystemSetup INVOKE for the circuit causes a state change to *Active*. 20
21
22
- o) Receiving an InterSystemSetup INVOKE for the circuit causes no state change. (An InterSystemSetup RETURN ERROR should also be sent back.) 23
24
- p) Receiving an InterSystemSetup RETURN RESULT for the circuit is not valid. 25
26
- 4) If an MSC has a circuit in the state *Locally and Remotely Blocked*, then : 27
- a) Sending a Blocking INVOKE for the circuit causes no state change. 28
- b) Receiving a Blocking INVOKE for the circuit causes no state change. (A Blocking RETURN RESULT should also be sent back.) 29
30
31
- c) Receiving a Blocking RETURN RESULT for the circuit causes no state change. 32
- d) Sending an Unblocking INVOKE for the circuit causes a state change to *Remotely Blocked*. 33
34
- e) Receiving an Unblocking INVOKE for the circuit causes a state change to *Locally Blocked*. (An Unblocking RETURN RESULT should also be sent back.) 35
36
37
- f) Receiving an Unblocking RETURN RESULT for the circuit is not valid. 38
- g) Sending a ResetCircuit INVOKE for the circuit causes a state change to *Remotely Blocked*. 39
40
41
- h) Receiving a ResetCircuit INVOKE for the circuit causes a state change to *Locally Blocked*. (A ResetCircuit RETURN RESULT with a trunk status of blocked should also be sent back.) 42
43
44
- i) Sending a ResetCircuit RETURN RESULT with a trunk status of idle is not allowed in *Locally and Remotely Blocked*. 45
46
47
- j) Receiving a ResetCircuit RETURN RESULT for the circuit is not valid. 48
- k) Sending a FacilitiesDirective INVOKE for the circuit is not allowed. 49
50
- l) Receiving a FacilitiesDirective INVOKE for the circuit causes a state change to *Locally Blocked*. (A FacilitiesDirective RETURN ERROR should also be sent back.) 51
52
53
- m) Receiving a FacilitiesDirective RETURN RESULT for the circuit is not valid. 54
55
- n) Sending an InterSystemSetup INVOKE for the circuit is not allowed. 56
57
58
59
60

- 1
- 2
- 3
- 4
- 5
- 6
- 7
- 8
- 9
- 10
- 11
- 12
- 13
- 14
- 15
- 16
- 17
- 18
- 19
- 20
- 21
- 22
- 23
- 24
- 25
- 26
- 27
- 28
- 29
- 30
- 31
- 32
- 33
- 34
- 35
- 36
- 37
- 38
- 39
- 40
- 41
- 42
- 43
- 44
- 45
- 46
- 47
- 48
- 49
- 50
- 51
- 52
- 53
- 54
- 55
- 56
- 57
- 58
- 59
- 60
- o) Receiving an InterSystemSetup INVOKE for the circuit causes a state change to *Locally Blocked*. (An InterSystemSetup RETURN ERROR should also be sent back.)
 - p) Receiving an InterSystemSetup RETURN RESULT for the circuit is not valid.

5.1.5 Other Actions on Receipt of a Blocking INVOKE

In the event of the receipt of a Blocking INVOKE:

- 1) after a FacilitiesDirective or InterSystemSetup INVOKE has been sent, and
- 2) before a response to the FacilitiesDirective or InterSystemSetup INVOKE has been received, an automatic repeat attempt shall be made on another circuit. The MSC receiving the Blocking INVOKE should release the original attempt in the normal manner after sending the Blocking RETURN RESULT.

If a Blocking INVOKE is received:

- 1) by an MSC after a FacilitiesDirective or InterSystemSetup RETURN RESULT has been received in response to a previous FacilitiesDirective or InterSystemSetup INVOKE that was sent, or
- 2) by an MSC that has received a FacilitiesDirective or InterSystemSetup INVOKE, the MSC shall not seize the related circuit for subsequent handoffs. However, the handoff procedure that is currently in progress on this circuit is not affected.

The fact that the circuit is engaged on a call shall not delay transmission of the Blocking (Unblocking) RETURN RESULT.

If an MSC sends a Blocking INVOKE and subsequently receives a FacilitiesDirective or InterSystemSetup INVOKE, a FacilitiesDirective or InterSystemSetup RETURN ERROR is returned. The MSC that sent the FacilitiesDirective or InterSystemSetup INVOKE should send the Blocking RETURN RESULT and automatically make a repeat attempt to seize a different circuit by sending the FacilitiesDirective or InterSystemSetup INVOKE for another circuit.

5.1.6 State Transition Table

Table 8 describes the action to be taken when a message shown in column 1 is received while the circuit is in one of the states shown in columns 2 through 5. Each cell at the intersection of a row and column shows:

New State
Response

where:

New State is the state the circuit should go to following receipt of the message. (*not valid*) indicates that the message should not be received in this state; if it is, local recovery procedures should be initiated by the receiving MSC (see 5.2.4).

Response is the message to be sent in response to the received message. “—” indicates that no response is required.

The state transition table assumes that a transaction on a given circuit shall be allowed to complete before the originating MSC initiates a new transaction for that circuit. This prevents ambiguity in determining the action to be taken when a response to a transaction is received. Note; however, that the table does allow transactions for the same circuit to be simultaneously initiated by both of the connected MSCs. In these cases, the circuit may pass through two states before the initiated transaction completes.

Table 9 describes the action to be taken at the time when a message shown in column 1 is transmitted while the circuit is in one of the states shown in columns 2 through 5. Each cell at the intersection of a row and column shows:

New State

where

New State is the state the circuit should go to following transmission of the message. *Not valid* indicates that the message should not be transmitted in this state; if it is, local recovery procedures should be initiated by the transmitting MSC (see 5.2.4).

1
2
3
4
5
6
7
8
9
10
11
12
13
14
15
16
17
18
19
20
21
22
23
24
25
26
27
28
29
30
31
32
33
34
35
36
37
38
39
40
41
42
43
44
45
46
47
48
49
50
51
52
53
54
55
56
57
58
59
60

Table 8 State Transition After Message Received

MESSAGE RECEIVED	CURRENT STATE			
	Active (ACT)	Locally Blocked (LB)	Remotely Blocked (RB)	Locally and Remotely Blocked (LRB)
Blocking INVOKE	RB Blocking RETURN RESULT	LRB Blocking RETURN RESULT	RB Blocking RETURN RESULT	LRB Blocking RETURN RESULT
Blocking RETURN RESULT	(not valid)	LB	(not valid)	LRB
Blocking RETURN ERROR	(not valid)	LB —	(not valid)	LRB —
ResetCircuit INVOKE ²	ACT ResetCircuit RETURN RESULT (idle)	LB ResetCircuit RETURN RESULT (blocked)	ACT ResetCircuit RETURN RESULT (idle)	LB ResetCircuit RETURN RESULT (blocked)
ResetCircuit RETURN RESULT (idle)	ACT —	(not valid)	ACT —	(not valid)
ResetCircuit RETURN RESULT (blocked)	RB —	(not valid)	RB —	(not valid)
ResetCircuit RETURN ERROR	RB —	(not valid)	RB —	(not valid)
Unblocking INVOKE	ACT Unblocking RETURN RESULT	LB Unblocking RETURN RESULT	ACT Unblocking RETURN RESULT	LB Unblocking RETURN RESULT
Unblocking RETURN RESULT	ACT —	(not valid)	RB —	(not valid)
Unblocking RETURN ERROR	ACT ResetCircuit	(not valid)	RB ResetCircuit	(not valid)
FacilitiesDirective and FacilitiesDirective2_ INVOKE	ACT FacilitiesDirective and Facilities- Directive2 RETURN RESULT	LB FacilitiesDirective and Facilities- Directive2 RETURN ERROR ³	ACT Facilities- Directive and Facilities- Directive2 RETURN RESULT	LB FacilitiesDirective and Facilities- Directive2 RETURN ERROR ²
FacilitiesDirective and FacilitiesDirective2_ RETURN RESULT	ACT —	(not valid)	(not valid)	(not valid)

²Disconnect any call in progress on the circuit. If the circuit is looped for Trunk Testing, remove the loop back condition.

³The Blocking INVOKE message may be repeated.

Table 8 State Transition After Message Received (continued)

MESSAGE RECEIVED	CURRENT STATE			
	<i>Active</i> (ACT)	Locally Blocked (LB)	Remotely Blocked (RB)	Locally and Remotely Blocked (LRB)
FacilitiesDirective and FacilitiesDirective2_ RETURN ERROR (shortage)	ACT —	(not valid)	(not valid)	(not valid)
FacilitiesDirective and FacilitiesDirective2 RETURN ERROR (unavailable)	ACT —	(not valid)	(not valid)	(not valid)
FacilitiesRelease INVOKE	ACT FacilitiesRelease RETURN RESULT	LB FacilitiesRelease RETURN RESULT	RB FacilitiesRelease RETURN RESULT	LRB FacilitiesRelease RETURN RESULT
FacilitiesRelease RETURN RESULT	ACT —	LB —	RB —	LRB —
FacilitiesRelease RETURN ERROR	ACT —	LB —	RB —	LRB —
HandoffBack and HandoffBack2 INVOKE	ACT HandoffBack and HandoffBack2 RETURN RESULT	(not valid)	(not valid)	(not valid)
HandoffBack and HandoffBack2 RETURN RESULT	ACT	(not valid)	(not valid)	(not valid)
HandoffBack and HandoffBack2 RETURN ERROR	ACT	(not valid)	(not valid)	(not valid)
HandoffToThird and HandoffToThird2 INVOKE	ACT HandoffToThird and HandoffToThird2 RETURN RESULT	(not valid)	(not valid)	(not valid)
HandoffToThird and HandoffToThird2 RETURN RESULT	ACT	(not valid)	(not valid)	(not valid)
HandoffToThird and HandoffToThird2 RETURN ERROR	ACT	(not valid)	(not valid)	(not valid)

1
2
3
4
5
6
7
8
9
10
11
12
13
14
15
16
17
18
19
20
21
22
23
24
25
26
27
28
29
30
31
32
33
34
35
36
37
38
39
40
41
42
43
44
45
46
47
48
49
50
51
52
53
54
55
56
57
58
59
60

Table 8 State Transition After Message Received (concluded)

MESSAGE RECEIVED	CURRENT STATE			
	<i>Active</i> (ACT)	Locally Blocked (LB)	Remotely Blocked (RB)	Locally and Remotely Blocked (LRB)
InterSystemSetup INVOKE	ACT InterSystem-Setup RETURN RESULT	LB InterSystem-Setup RETURN ERROR ²	ACT InterSystem-Setup RETURN RESULT	LB InterSystem-Setup RETURN ERROR ²
InterSystemSetup RETURN RESULT	ACT —	(not valid)	(not valid)	(not valid)
InterSystemSetup RETURN ERROR (shortage)	ACT —	(not valid)	(not valid)	(not valid)
InterSystemSetup RETURN ERROR (unavailable)	ACT —	(not valid)	(not valid)	(not valid)
TrunkTest INVOKE	ACT TrunkTest RETURN RESULT	LB TrunkTest RETURN RESULT	RB TrunkTest RETURN RESULT	LRB TrunkTest RETURN RESULT
TrunkTest RETURN RESULT	ACT —	LB —	RB —	LRB —
TrunkTest RETURN ERROR	ACT —	LB —	RB —	LRB —
TrunkTestDisconnect INVOKE	ACT TrunkTest-Disconnect RETURN RESULT	LB TrunkTest-Disconnect RETURN RESULT	RB TrunkTest-Disconnect RETURN RESULT	LRB TrunkTest-Disconnect RETURN RESULT
TrunkTestDisconnect RETURN RESULT	ACT —	LB —	RB —	LRB —
TrunkTestDisconnect RETURN ERROR	RB —	LRB —	RB —	LRB —

²The Blocking INVOKE message may be repeated.

Table 9 State Transition After Message Transmitted

MESSAGE TRANSMITTED	CURRENT STATE			
	<i>Active</i> (ACT)	Locally Blocked (LB)	Remotely Blocked (RB)	Locally and Remotely Blocked (LRB)
Blocking INVOKE	LB	LB	LRB	LRB
Blocking RETURN RESULT	RB	LRB	RB	LRB
Blocking RETURN ERROR	ACT	LB	RB	LRB
ResetCircuit INVOKE	ACT	ACT	RB	RB
ResetCircuit RETURN RESULT (idle)	ACT	(not valid)	ACT	(not valid)
ResetCircuit RETURN RESULT (blocked)	(not valid)	LB	(not valid)	LB
ResetCircuit RETURN ERROR	LB	LB	LB	LB
Unblocking INVOKE	ACT	ACT	RB	RB
Unblocking RETURN RESULT	ACT	LB	ACT	LB
Unblocking RETURN ERROR	ACT	LB	RB	LRB
FacilitiesDirective and FacilitiesDirective2 INVOKE	ACT	ACT	(not valid)	(not valid)
FacilitiesDirective and FacilitiesDirective2 RETURN RESULT	ACT	(not valid)	ACT	(not valid)
FacilitiesDirective and FacilitiesDirective2 RETURN ERROR (shortage)	ACT	LB	ACT	LB
FacilitiesDirective and FacilitiesDirective2 RETURN ERROR (unavailable)	ACT	LB	ACT	LB
FacilitiesRelease INVOKE	ACT	LB	RB	LRB
FacilitiesRelease RETURN RESULT	ACT	LB	RB	LRB
FacilitiesRelease RETURN ERROR	ACT	LB	RB	LRB

1
2
3
4
5
6
7
8
9
10
11
12
13
14
15
16
17
18
19
20
21
22
23
24
25
26
27
28
29
30
31
32
33
34
35
36
37
38
39
40
41
42
43
44
45
46
47
48
49
50
51
52
53
54
55
56
57
58
59
60

Table 9 State Transition After Message Transmitted (concluded)

MESSAGE TRANSMITTED	CURRENT STATE			
	<i>Active</i> (ACT)	<i>Locally Blocked</i> (LB)	<i>Remotely Blocked</i> (RB)	<i>Locally and Remotely Blocked</i> (LRB)
HandoffBack, HandoffBack2 HandoffToThird and HandoffToThird2 INVOKE	ACT	(not valid)	(not valid)	(not valid)
HandoffBack, HandoffBack2 HandoffToThird and HandoffToThird2 RETURN RESULT	ACT	(not valid)	(not valid)	(not valid)
HandoffBack, HandoffBack2 HandoffToThird and HandoffToThird2 RETURN ERROR	ACT	(not valid)	(not valid)	(not valid)
InterSystemSetup INVOKE	ACT	ACT	(not valid)	(not valid)
InterSystemSetup RETURN RESULT	ACT	(not valid)	ACT	(not valid)
InterSystemSetup RETURN ERROR (shortage)	ACT	LB	ACT	LB
InterSystemSetup RETURN ERROR (unavailable)	ACT	LB	ACT	LB
TrunkTest INVOKE	ACT	LB	RB	LRB
TrunkTest RETURN RESULT	ACT	LB	RB	LRB
TrunkTest RETURN ERROR	ACT	LB	RB	LRB
TrunkTestDisconnect INVOKE	ACT	LB	RB	LRB
TrunkTestDisconnect RETURN RESULT	ACT	LB	RB	LRB
TrunkTestDisconnect RETURN ERROR	ACT	LB	RB	LRB

5.2 ABNORMAL CONDITIONS

5.2.1 Dual Seizure (glare)

It is possible that the two MSCs can attempt to seize the same circuit at approximately the same time, since the circuits have the capability of bi-directional operation.

5.2.1.1 Unguarded Interval

Dual seizure is possible only during the Unguarded Interval, from the time when the FacilitiesDirective or InterSystemSetup INVOKE is sent by the Serving MSC until it is received by the Target MSC. Both MSCs must detect dual seizure and take the actions defined in Section 5.2.1.4.

5.2.1.2 Detection of Dual Seizure

A dual seizure is detected by an MSC from the fact that it receives a FacilitiesDirective, InterSystemSetup (or TrunkTest) INVOKE for a circuit for which it has sent a FacilitiesDirective, InterSystemSetup (or TrunkTest) INVOKE.

5.2.1.3 Preventative Action for Dual Seizure

It is necessary to take preventive action in cases where a signaling data link with long propagation time is used. Different methods for circuit selection can be envisioned to minimize the occurrence of dual seizure. In the following, two methods are described.

Cellular system operators establishing bi-directional interMSC facilities must agree on the specific application of these methods.

An opposite order of selection is used at each MSC terminating a bi-directional circuit group.

For call control purposes a bi-directional circuit group can be subdivided into subgroups in an MSC. Each MSC terminating a bi-directional circuit group would then have priority access to the group of circuits for which it is controlling (see 5.2.1.4). Of this group the circuit which has been released the longest is selected (first-in, first-out). In addition each MSC terminating a bi-directional circuit group would have non-priority access to the group of circuits which it is not controlling. Of this group the latest released is selected (last-in, first-out).

5.2.1.4 Action To Be Taken On Detection Of Dual Seizure

On detection of dual seizure, the call being processed by the control MSC for that circuit shall be completed and the received FacilitiesDirective or InterSystemSetup INVOKE shall be disregarded.

Under these conditions, the call being processed by the control MSC shall be allowed to mature. The call being processed by the non-control MSC shall be backed off and the switch path released. A FacilitiesRelease INVOKE shall not be sent. The non-control MSC shall make an automatic repeat attempt on the same or an alternative route.

5.2.2 Reset of Circuits

In systems which maintain circuit status in memory there may be occasions when the memory becomes corrupted. In such a case the circuits must be reset to the idle condition at both MSCs to make them available for new traffic. Since the MSC with the corrupted memory does not know whether the circuits are idle, busy outgoing, busy incoming, blocked, etc., ResetCircuit INVOKEs should be sent for affected circuits. The ResetCircuit INVOKE should also be sent when circuits are placed into service.

5.2.2.1 Reset Circuit Signal

Refer to the MSC sending the ResetCircuit INVOKE as the Near MSC. Refer to the MSC receiving the ResetCircuit INVOKE as the Far MSC.

- 1) If the Near MSC sends a ResetCircuit INVOKE, then:
 - a) If a handoff or trunk test is being setup or is currently established on the circuit related to the ResetCircuit INVOKE, then the handoff or trunk test should be canceled and cleared for the related circuit on both MSCs regardless of the blocking state of the circuit.
 - b) The Far MSC should respond by sending a ResetCircuit RETURN RESULT indicating a trunk status of idle if the Far MSC has the circuit in the *Remotely Blocked* or *Active* state.
 - c) The Far MSC should respond by sending a ResetCircuit RETURN RESULT indicating a trunk status of blocked if the Far MSC has the circuit in the *Locally Blocked* or *Locally and Remotely Blocked* state.
 - d) See 5.1.6 for all of the state transitions involving ResetCircuit INVOKE and ResetCircuit RETURN RESULT.
- 2) If the Near MSC receives a ResetCircuit RETURN ERROR, and:
 - a) The Near MSC has the circuit in the *Active* state, then the Near MSC changes the circuit to the *Remotely Blocked* state.
 - b) The Near MSC has the circuit in the *Remotely Blocked* state, then the Near MSC remains in this state.
 - c) The Near MSC has the circuit in the *Locally Blocked* state, then this is not possible because the state should be *Active* or *Remotely Blocked* after the ResetCircuit INVOKE was sent.
 - d) The Near MSC has the circuit in the *Locally and Remotely Blocked* state, then this is not possible because the state should be *Active* or *Remotely Blocked* after a ResetCircuit INVOKE was sent.

- 3) If the Near MSC receives no response within the Reset Circuit time-out interval, then:
 - a) Repeat sending ResetCircuit INVOKE at intervals in accordance with internal algorithms.
 - b) If no response is received after the maximum number of repeats attempts dictated by internal algorithms:
 - Remove the circuit from service
 - Alert maintenance personnel.

5.2.3 Failure in the Blocking and Unblocking Sequences

If no RETURN RESULT or RETURN ERROR is received within the value specified in table 10 of a Blocking (Unblocking) INVOKE, the MSC shall repeat the original Blocking (Unblocking) INVOKE at intervals in accordance with internal algorithms. This shall continue until a RETURN RESULT or RETURN ERROR is received, or if no response is received, after the maximum number of repeat attempts dictated by internal algorithms.

- 1) If an MSC has a circuit in the state *Active*, then:
 - a) Receiving a Blocking RETURN ERROR for the circuit is not possible because the state should be *Locally Blocked* or *Locally and Remotely Blocked* after the Blocking INVOKE was sent.
 - b) Receiving an Unblocking RETURN ERROR for the circuit causes no state change, and a ResetCircuit INVOKE should be sent out for the circuit.
 - c) Receiving a FacilitiesDirective RETURN ERROR for the circuit causes no state change.
 - d) Receiving an InterSystemSetup RETURN ERROR for the circuit causes no state change.
- 2) If an MSC has a circuit in the state *Remotely Blocked*, then:
 - a) Receiving a Blocking RETURN ERROR for the circuit is not possible because the state should be *Locally Blocked* or *Locally and Remotely Blocked* after the Blocking INVOKE was sent.
 - b) Receiving an Unblocking RETURN ERROR for the circuit causes no state change, and a ResetCircuit INVOKE should be sent out for the circuit.
 - c) Receiving a FacilitiesDirective RETURN ERROR for the circuit is not possible because a FacilitiesDirective INVOKE could not have been sent on a circuit that was *Remotely Blocked*.
 - d) Receiving an InterSystemSetup RETURN ERROR for the circuit is not possible because an InterSystemSetup INVOKE could not have been sent on a circuit that was *Remotely Blocked*.
- 3) If an MSC has a circuit in the state *Locally Blocked*, then:
 - a) Receiving a Blocking RETURN ERROR for the circuit causes no state change.
 - b) Receiving an Unblocking RETURN ERROR for the circuit is not possible because the state should be *Active* or *Remotely Blocked* after the Unblocking INVOKE was sent.
 - c) Receiving a FacilitiesDirective RETURN ERROR for the circuit is not possible because the state should be *Active* after the FacilitiesDirective INVOKE was sent.
 - d) Receiving an InterSystemSetup RETURN ERROR for the circuit is not possible because the state should be *Active* after the InterSystemSetup INVOKE was sent.
- 4) If an MSC has a circuit in the state *Locally and Remotely Blocked*, then:

- a) Receiving a Blocking RETURN ERROR for the circuit causes no state change.
 - b) Receiving an Unblocking RETURN ERROR for the circuit is not possible because the state should be *Active* or *Remotely Blocked* after the Unblocking INVOKE was sent.
 - c) Receiving a FacilitiesDirective RETURN ERROR for the circuit is not possible because the state should be *Active* after the FacilitiesDirective INVOKE was sent.
 - d) Receiving an InterSystemSetup RETURN ERROR for the circuit is not possible because the state should be *Active* after the InterSystemSetup INVOKE was sent.
- 5) If no response is received after the maximum number of repeat attempts dictated by internal algorithms:
- a) Remove the circuit from service
 - b) Reset the circuit (see Section 5.2.2).

5.2.4 Receipt Of Unreasonable Signaling Information

The lower layers of the protocol shall avoid miss-sequencing, or double delivery of messages with a high reliability. However, undetected errors at the signaling link level and MSC malfunctions may produce signaling information messages that are either ambiguous or inappropriate.⁴

In order to resolve some possible ambiguities in the state of a circuit when unreasonable messages are received the following shall apply:

- 1) If a FacilitiesRelease INVOKE is received relating to a circuit that is not seized for a handoff or a trunk test, it shall be acknowledged with a FacilitiesRelease RETURN RESULT.
- 2) If a Blocking INVOKE is received for a blocked circuit, a Blocking RETURN RESULT shall be sent.
- 3) If an Unblocking INVOKE is received for an unblocked circuit, an Unblocking RETURN RESULT shall be sent.
- 4) If other unreasonable signaling information is received, the following actions shall be taken:
 - a) If the circuit is idle, the ResetCircuit INVOKE is sent. The ResetCircuit INVOKE shall ensure that any handoff or trunk test that the Far MSC may consider established is disconnected, and shall resynchronize the circuit state records of the two MSCs.
 - b) If the circuit is allocated for a handoff forward or a trunk test, after receipt of a FacilitiesDirective, InterSystemSetup, or TrunkTest RETURN RESULT, the unreasonable signaling information is discarded.
 - c) If the circuit is allocated for a handoff forward or a trunk test, before receipt of a FacilitiesDirective, InterSystemSetup, or TrunkTest RETURN RESULT, the ResetCircuit INVOKE is sent. If the circuit is allocated for a handoff forward, automatic repeat attempt is provided on another circuit. The ResetCircuit INVOKE shall ensure that any handoff or trunk test that the Far MSC may consider

⁴See 5.1.6.

established is disconnected, and shall resynchronize the circuit state records of the two MSCs.

- d) If the circuit is *Locally Blocked* or *Locally and Remotely Blocked*, the Blocking INVOKE is sent.

Except in certain cases (see 5.2.1) any other unreasonable signaling information received shall be discarded. If the discarding of the messages prevents a call from being completed, that call shall eventually be released by the expiration of a timer. Possible further actions to be taken on unreasonable signaling information are for further study.

5.2.5 Loss of Messages in the Release Sequence

5.2.5.1 Failure to Receive a FacilitiesRelease RETURN RESULT

If a FacilitiesRelease RETURN RESULT is not received in response to a FacilitiesRelease INVOKE before the Clear Trunk Timer (CTT) timer expires, the MSC shall:

- 1) Repeat sending of FacilitiesRelease INVOKE at intervals in accordance with internal algorithms and then;
- 2) If no response is received after the maximum number of repeat attempts dictated by internal algorithms:
 - a) Remove the circuit from service.
 - b) Reset the circuit (see Section 5.2.2).

5.2.6 Other Failure Conditions

5.2.6.1 Inability to Release in Response to a FacilitiesRelease INVOKE

If an MSC is unable to return the circuit to the idle condition in response to a FacilitiesRelease INVOKE, it shall immediately remove the circuit from service, alert maintenance personnel and send a FacilitiesRelease RETURN ERROR indicating *Trunk Unavailable*. The circuit shall be considered blocked until an Unblocking or ResetCircuit INVOKE is received.

5.3 OA M TIMER VALUES FOR HANDOFF CIRCUITS

Table 10 Handoff OA M Timer Values

Timer	Default (sec.)	Started when	Normally stopped when	Action when timer expires
Blocking Timer BLKT	4 to 15	When MSC sends Blocking INVOKE	When MSC receives Blocking RETURN RESULT or RETURN ERROR	see 5.2.3
ResetCircuit Timer RSTT	4 to 15	MSC sends ResetCircuit INVOKE	When MSC receives ResetCircuit RETURN RESULT or RETURN ERROR	see 5.2.2.1
Unblocking Timer UBLKT	4 to 15	MSC sends Unblocking INVOKE	When MSC receives Unblocking RETURN RESULT or RETURN ERROR	see 5.2.3

6. INTERMSC TRUNK TESTING

6.1 INTRODUCTION

Because all signaling data including the supervisory and address signals necessary to control call setup and take down, as well as network management signals between two MSCs of different systems shall be carried over a common channel signaling link, there shall be no signals passed over the transit trunks carrying the voice conversations. As a result, alternate means must be implemented to verify the acceptability of the voice trunks. Trunk testing can occur regardless of the blocking condition on either side of the trunk to be tested. Responses to Blocking or Unblocking INVOKEs should not be affected or delayed when either MSC is setting up or executing a trunk test (responses should be the same as when the trunk is not seized for a handoff or a trunk test). An MSC receiving a TrunkTest INVOKE after it has sent a TrunkTest INVOKE should respond to the TrunkTest INVOKE it received with a TrunkTest RETURN ERROR or check the glare resolution table used for handoff glare situations to determine which TrunkTest response to send. A TrunkTest RETURN ERROR would be sent if the MSC determined it was the controlling MSC, and a TrunkTest RETURN RESULT would be sent if it determined it was the non-controlling MSC.

In this section a method to verify the acceptability of the audio path is proposed.

The tests are intended for circuits which contain an analog part only.

6.2 TEST DESCRIPTION

These diagnostics would be activated automatically every Δ hours at some delta off the hour mark. For purpose of discussion, let Δ equal 2 hours and let the delta value be 20 minutes.

The audio path of each transit trunk would be subject to two functional tests, one test being a valid transmission level test and the other test being a valid noise level test.

The test equipment consists of:

- 1) a -16 dBm 1004 Hz Test Tone or a -12 dBm 2004 Hz Test Tone;
- 2) a 600 Ohm Quiet Termination;
- 3) a Transmission/Noise Measurement Receiver capable of performing a transmission level measurement and a noise level measurement.

The MSC to MSC transit trunk testing is performed on interMSC transit trunks as shown in Figure 6 and Figure 7. Figure 6 shows the transmission level measurement configuration which consists of the Test Tone applied to the transmit-audio-path of the transit trunk at MSC-A. At MSC-B the receive-audio-path of the transit trunk is looped back onto the transmit-audio-path of the trunk to MSC-A. At MSC-A a transmission measurement receiver is connected to the receive-audio-path of the trunk. The transmission measurement receiver measures the received tone level. Figure 7 shows the noise level measurement configuration which consists of the 600 Ohm Quiet Termination applied to the transmit-audio-path of the transit trunk at MSC-A. The audio path is looped at MSC-B, and the noise

measurement receiver is connected to the receive-audio-path of the trunk. The noise measurement receiver measures the circuit noise level.

If a valid (within a + or - tone level range) tone level is not detected or if there is excessive noise on the trunk, MSC-A shall issue a command to put the transit trunk out-of-service and shall generate a status message that reports the test results.

The test procedure outlined above is performed on every interMSC transmit trunk that is:

- 1) a one-way out-going trunk, or
- 2) a two-way trunk.

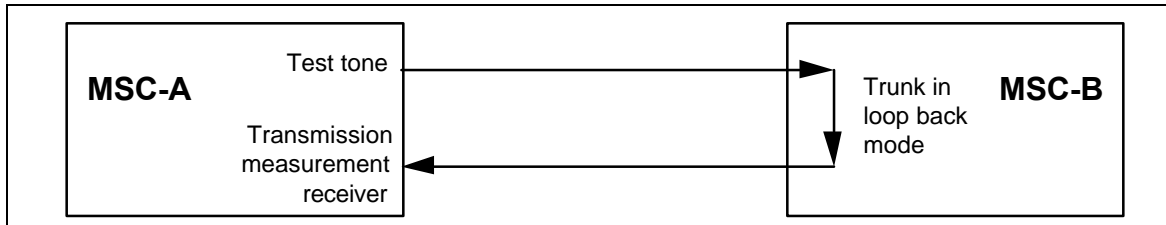

Figure 6 InterMSC Transmission Diagram

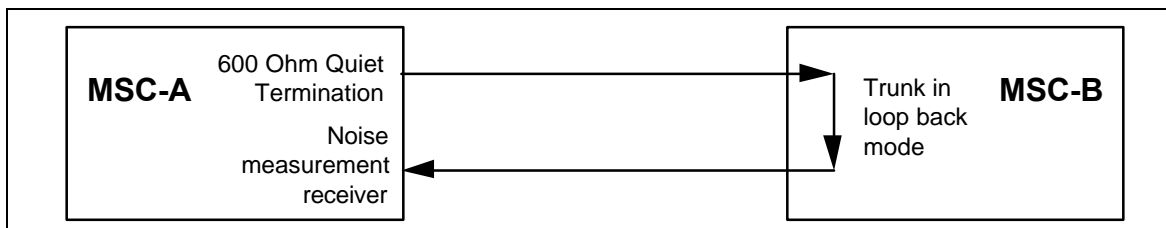

Figure 7 InterMSC Noise Diagram

The received transmission levels and noise levels at which the transit trunks shall be put out-of-service are for further study. Trunks shall be placed out-of-service via the Blocking INVOKE.

6.3 TEST PROCEDURES

6.3.1 Trunk Test Request

If an MSC elects (using its internal algorithms) to initiate a test of an interMSC trunk, it shall:

- 1) Send a TrunkTest INVOKE.
- 2) Set the Trunk Test Timer (TTT).
- 3) While timer (TTT) has not expired:
 - a) If a TrunkTest RETURN RESULT is received:

- Stop timer (TTT).
 - Exit this task and initiate trunk testing in accordance with the MSC's internal algorithms.
- b) If a TrunkTest ERROR RESULT is received:
- Stop timer (TTT).
 - Exit this task and execute recovery procedures in accordance with internal algorithms.
- 4) If timer (TTT) expires, then repeat sending of TrunkTest INVOKE at intervals in accordance with internal MSC algorithms. This should continue until a RETURN RESULT or RETURN ERROR is received or internal MSC algorithms determine the test should be aborted.

6.3.2 Trunk Test Reply

If a TrunkTest INVOKE is received, the MSC shall determine if the test call will be accepted using its internal algorithms.

If the test call is accepted, the MSC shall loop back the trunk and then return TrunkTest RETURN RESULT.

If the test call is not accepted, the MSC shall return TrunkTest RETURN ERROR and execute recovery procedures in accordance with its internal algorithms.

6.3.3 Trunk Test Disconnect Request

When the MSC elects (using its internal algorithms) to end testing of an interMSC trunk, it shall:

- 1) Send a TrunkTestDisconnect INVOKE.
- 2) Set the Trunk Test Disconnect Timer (TTDT).
- 3) While timer (TTDT) has not expired:
 - a) If a TrunkTestDisconnect RETURN RESULT is received:
 - Stop timer (TTDT).
 - Exit this task and restore the trunk to traffic.
 - b) If a TrunkTestDisconnect RETURN ERROR is received:
 - Stop timer (TTDT).
 - Remove trunk from traffic and exit this task.
- 4) If timer (TTDT) expires:
 - a) Repeat sending of TrunkTestDisconnect INVOKE at intervals determined by internal MSC algorithms. Continue until a RETURN RESULT or RETURN ERROR is received or internal MSC algorithms determine the trunk should be removed from service.

6.3.4 Trunk Test Disconnect Reply

If a TrunkTestDisconnect INVOKE is received, the MSC shall return TrunkTestDisconnect RETURN RESULT and shall return the trunk to its previous state.

6.4 OA M TIMER VALUES FOR TRUNK TESTING

Table 11 Trunk Test Timer Values

Timer	Default (sec.)	Started when	Normally stopped when	Action when timer expires
TTT Trunk Test Timer	4 to 15	When MSC sends TrunkTest INVOKE	When MSC receives TrunkTest RETURN RESULT or RETURN ERROR	see 6.3.1
TTDT Trunk Test Disconnect Timer	4 to 15	When MSC sends TrunkTest- Disconnect INVOKE	When MSC receives TrunkTestDisconnect RETURN RESULT or RETURN ERROR	see 6.3.3

7. ISSUES FOR FURTHER STUDY

- 1) Configuration Control and Failure Recovery.
- 2) Operational Measurements.
- 3) Data Link Performance.

CELLULAR RADIOTELECOMMUNICATIONS INTERSYSTEM OPERATIONS:
CHAPTER 5
SIGNALING PROTOCOLS

CONTENTS

1	LIST OF FIGURES.....	viii
2	LIST OF TABLES xii
3	FOREWORD	xvii
4	REVISION HISTORY.....	xxi
5	1 INTRODUCTION.....	1
6	1.1 OBJECTIVE.....	1
7	1.2 SCOPE	1
8	1.3 ORGANIZATION.....	2
9	2 REFERENCES.....	2
10	3 TERMINOLOGY	2
11	3.1 DEFINITION.....	2
12	3.2 SYMBOLS AND ABBREVIATIONS.....	2
13	4 MAP PROTOCOL ARCHITECTURE.....	3
14	5 DATA TRANSFER SERVICES.....	. 6
15	5.1 SS7-BASED DATA TRANSFER SERVICES.....	6
16	5.1.1 Message Transfer Part	6
17	5.1.2 Signaling Connection Control Part	8
18	5.2 X.25-BASED DATA TRANSFER SERVICES	10
19	5.3 ITU-7-BASED DATA TRANSFER SERVICES.....	11
20	5.3.1 Message Transfer Part	11
21	5.3.2 Signaling Connection Control Part	11
22	6 APPLICATION SERVICES.....	14
23	6.1 APPLICATION SERVICES ARCHITECTURE.....	14
24	6.2 APPLICATION LAYER STRUCTURE.....	15
25	6.3 TCAP FORMATS AND PROCEDURES.....	15
26	6.3.1 Transaction Portion	15
27	6.3.2 Component Portion.....	16
28	6.3.2.1 TCAP INVOKE Component	17
29	6.3.2.2 TCAP RETURN RESULT Component.....	17
30	6.3.2.3 TCAP RETURN ERROR Component.....	18
31	6.3.2.4 TCAP REJECT Component	23
32	6.4 MAP OPERATIONS	24

1	6.4.1	General	24
2	6.4.1.1	Operation Formats	24
3	6.4.1.2	Operation Specifiers	24
4	6.4.1.3	Mapping of Operations onto TCAP Package Types	26
5	6.4.2	Operation Definitions	27
6	6.4.2.1	AuthenticationDirective	29
7	6.4.2.2	AuthenticationDirectiveForward	31
8	6.4.2.3	AuthenticationFailureReport	32
9	6.4.2.4	AuthenticationRequest	34
10	6.4.2.5	AuthenticationStatusReport.....	36
11	6.4.2.6	BaseStationChallenge	38
12	6.4.2.7	Blocking.....	39
13	6.4.2.8	BulkDeregistration.....	40
14	6.4.2.9	CountRequest	41
15	6.4.2.10	FacilitiesDirective.....	42
16	6.4.2.11	FacilitiesDirective2.....	44
17	6.4.2.12	FacilitiesRelease	47
18	6.4.2.13	FeatureRequest	48
19	6.4.2.14	FlashRequest	52
20	6.4.2.15	HandoffBack	53
21	6.4.2.16	HandoffBack2	55
22	6.4.2.17	HandoffMeasurementRequest	58
23	6.4.2.18	HandoffMeasurementRequest2.....	59
24	6.4.2.19	HandoffToThird	61
25	6.4.2.20	HandoffToThird2.....	63
26	6.4.2.21	InformationDirective.....	66
27	6.4.2.22	InformationForward.....	68
28	6.4.2.23	InterSystemAnswer.....	70
29	6.4.2.24	InterSystemPage.....	71
30	6.4.2.25	InterSystemPage2	74
31	6.4.2.26	InterSystemSetup.....	76
32	6.4.2.27	LocationRequest.....	77
33	6.4.2.28	MobileOnChannel	79
34	6.4.2.29	MSInactive	80
35	6.4.2.30	OriginationRequest	81
36	6.4.2.31	QualificationDirective.....	84
37	6.4.2.32	QualificationRequest.....	86
38	6.4.2.33	RandomVariableRequest.....	88
39	6.4.2.34	RedirectionDirective.....	89
40	6.4.2.35	RedirectionRequest.....	91
41	6.4.2.36	RegistrationCancellation	92
42	6.4.2.37	RegistrationNotification	94
43	6.4.2.38	RemoteUserInteractionDirective.....	97
44	6.4.2.39	ResetCircuit.....	98
45	6.4.2.40	RoutingRequest	99
46	6.4.2.41	SMSDeliveryBackward	102
47	6.4.2.42	SMSDeliveryForward.....	104
48	6.4.2.43	SMSDeliveryPointToPoint.....	106

1		6.4.2.44	SMSNotification.....	108
2		6.4.2.45	SMSRequest.....	109
3		6.4.2.46	TransferToNumberRequest.....	110
4		6.4.2.47	TrunkTest.....	113
5		6.4.2.48	TrunkTestDisconnect.....	114
6		6.4.2.49	Unblocking.....	115
7		6.4.2.50	UnreliableRoamerDataDirective.....	116
8		6.4.2.51	UnsolicitedResponse.....	117
9				
10				
11	6.5	MAP PARAMETERS.....		119
12		6.5.1	General.....	119
13		6.5.1.1	Parameter Format.....	119
14		6.5.1.2	Parameter Identifiers.....	119
15				
16		6.5.2	Parameter Definitions.....	128
17		6.5.2.1	AccessDeniedReason.....	128
18		6.5.2.2	ActionCode.....	129
19		6.5.2.3	AlertCode.....	130
20		6.5.2.4	AlertResult.....	132
21		6.5.2.5	AnnouncementCode.....	133
22		6.5.2.6	AnnouncementList.....	141
23		6.5.2.7	AuthenticationAlgorithmVersion.....	142
24		6.5.2.8	AuthenticationCapability.....	143
25		6.5.2.9	AuthenticationData.....	144
26		6.5.2.10	AuthenticationResponse.....	145
27		6.5.2.11	AuthenticationResponseBaseStation.....	146
28		6.5.2.12	AuthenticationResponseUniqueChallenge.....	146
29		6.5.2.13	AuthorizationDenied.....	147
30		6.5.2.14	AuthorizationPeriod.....	148
31		6.5.2.15	AvailabilityType.....	149
32		6.5.2.16	BillingID.....	150
33		6.5.2.17	BorderCellAccess.....	151
34		6.5.2.18	CallHistoryCount.....	152
35		6.5.2.19	CallHistoryCountExpected.....	152
36		6.5.2.20	CallingFeaturesIndicator.....	153
37		6.5.2.21	CallingPartyNumberDigits1.....	155
38		6.5.2.22	CallingPartyNumberDigits2.....	156
39		6.5.2.23	CallingPartyNumberString1.....	157
40		6.5.2.24	CallingPartyNumberString2.....	158
41		6.5.2.25	CallingPartySubaddress.....	159
42		6.5.2.26	CancellationDenied.....	160
43		6.5.2.27	CancellationType.....	161
44		6.5.2.28	CarrierDigits.....	162
45		6.5.2.29	CDMACallMode.....	163
46		6.5.2.30	CDMAChannelData.....	164
47		6.5.2.31	CDMACodeChannel.....	166
48		6.5.2.32	CDMACodeChannelInformation.....	166
49		6.5.2.33	CDMACodeChannelList.....	167
50		6.5.2.34	CDMA Mobile Protocol Revision.....	167
51		6.5.2.35	CDMAPilotStrength.....	168
52				
53				
54				
55				
56				
57				
58				
59				
60				

1	6.5.2.36	CDMAPrivateLongCodeMask.....	169
2	6.5.2.37	CDMASearchWindow.....	170
3	6.5.2.38	CDMAServingOneWayDelay.....	170
4	6.5.2.39	CDMASignalQuality.....	171
5	6.5.2.40	CDMASlotCycleIndex.....	171
6	6.5.2.41	CDMAStationClassMark.....	172
7	6.5.2.42	CDMATargetMAHOInformation.....	173
8	6.5.2.43	CDMATargetMAHOList.....	173
9	6.5.2.44	CDMATargetMeasurementInformation.....	174
10	6.5.2.45	CDMATargetMeasurementList.....	174
11	6.5.2.46	CDMATargetOneWayDelay.....	175
12	6.5.2.47	ChannelData.....	176
13	6.5.2.48	ConditionallyDeniedReason.....	177
14	6.5.2.49	ConferenceCallingIndicator.....	178
15	6.5.2.50	ConfidentialityModes.....	179
16	6.5.2.51	ControlChannelData.....	180
17	6.5.2.52	CountUpdateReport.....	181
18	6.5.2.53	DeniedAuthorizationPeriod.....	182
19	6.5.2.54	DenyAccess.....	183
20	6.5.2.55	DeregistrationType.....	184
21	6.5.2.56	DestinationDigits.....	185
22	6.5.2.57	DigitCollectionControl.....	186
23	6.5.2.58	Digits.....	189
24	6.5.2.59	DMH_AccountCodeDigits.....	191
25	6.5.2.60	DMH_AlternateBillingDigits.....	192
26	6.5.2.61	DMH_BillingDigits.....	193
27	6.5.2.62	DMH_RedirectionIndicator.....	194
28	6.5.2.63	ElectronicSerialNumber.....	196
29	6.5.2.64	ExtendedMSCID.....	197
30	6.5.2.65	ExtendedSystemMyTypeCode.....	198
31	6.5.2.66	FaultyParameter.....	199
32	6.5.2.67	FeatureResult.....	200
33	6.5.2.68	GeographicAuthorization.....	201
34	6.5.2.69	GroupInformation.....	202
35	6.5.2.70	HandoffReason.....	203
36	6.5.2.71	HandoffState.....	204
37	6.5.2.72	InterMSCCircuitID.....	204
38	6.5.2.73	InterSwitchCount.....	205
39	6.5.2.74	IntersystemTermination.....	206
40	6.5.2.75	LegInformation.....	207
41	6.5.2.76	LocalTermination.....	208
42	6.5.2.77	LocationAreaID.....	209
43	6.5.2.78	MessageWaitingNotificationCount.....	210
44	6.5.2.79	MessageWaitingNotificationType.....	211
45	6.5.2.80	MobileDirectoryNumber.....	212
46	6.5.2.81	MobileIdentificationNumber.....	213
47	6.5.2.82	MSCID.....	214
48	6.5.2.83	MSCIdentificationNumber.....	215

1	6.5.2.84	MSLocation.....	216
2	6.5.2.85	NAMPSCallMode.....	217
3	6.5.2.86	NAMPSChannelData	218
4	6.5.2.87	NoAnswerTime.....	219
5	6.5.2.88	OneTimeFeatureIndicator.....	220
6	6.5.2.89	OriginationIndicator	222
7	6.5.2.90	OriginationTriggers	223
8	6.5.2.91	PACAIndicator	228
9	6.5.2.92	PageIndicator	229
10	6.5.2.93	PC_SSN.....	230
11	6.5.2.94	PilotBillingID	231
12	6.5.2.95	PilotNumber	232
13	6.5.2.96	PreferredLanguageIndicator	233
14	6.5.2.97	Profile.....	234
15	6.5.2.98	PSTNTermination	236
16	6.5.2.99	QualificationInformationCode	237
17	6.5.2.100	RANDC	238
18	6.5.2.101	RandomVariable	239
19	6.5.2.102	RandomVariableBaseStation.....	239
20	6.5.2.103	RandomVariableSSD	240
21	6.5.2.104	RandomVariableUniqueChallenge.....	240
22	6.5.2.105	RANDValidTime.....	241
23	6.5.2.106	ReceivedSignalQuality.....	241
24	6.5.2.107	RedirectingNumberDigits.....	242
25	6.5.2.108	RedirectingNumberString.....	243
26	6.5.2.109	RedirectingSubaddress	244
27	6.5.2.110	RedirectionReason	245
28	6.5.2.111	ReleaseReason.....	246
29	6.5.2.112	ReportType.....	247
30	6.5.2.113	RestrictionDigits	248
31	6.5.2.114	RoutingDigits.....	249
32	6.5.2.115	SeizureType.....	250
33	6.5.2.116	SenderIdentificationNumber.....	251
34	6.5.2.117	ServingCellID	252
35	6.5.2.118	SetupResult.....	252
36	6.5.2.119	SharedSecretData	253
37	6.5.2.120	SignalingMessageEncryptionKey	253
38	6.5.2.121	SignalQuality	254
39	6.5.2.122	SMS_AccessDeniedReason.....	256
40	6.5.2.123	SMS_Address	258
41	6.5.2.124	SMS_BearerData	260
42	6.5.2.125	SMS_CauseCode	262
43	6.5.2.126	SMS_ChargeIndicator	267
44	6.5.2.127	SMS_DestinationAddress.....	268
45	6.5.2.128	SMS_MessageCount.....	270
46	6.5.2.129	SMS_MessageWaitingIndicator	270
47	6.5.2.130	SMS_NotificationIndicator.....	271
48	6.5.2.131	SMS_OriginalDestinationAddress	272
49			
50			
51			
52			
53			
54			
55			
56			
57			
58			
59			
60			

1	6.5.2.132	SMS_OriginalDestinationSubaddress	275	
2	6.5.2.133	SMS_OriginalOriginatingAddress	276	
3	6.5.2.134	SMS_OriginalOriginatingSubaddress	279	
4	6.5.2.135	SMS_OriginatingAddress	280	
5	6.5.2.136	SMS_OriginationRestrictions	282	
6	6.5.2.137	SMS_TeleserviceIdentifier	283	
7	6.5.2.138	SMS_TerminationRestrictions	285	
8	6.5.2.139	SPINIPIN	286	
9	6.5.2.140	SPINITriggers	287	
10	6.5.2.141	SSDNotShared	292	
11	6.5.2.142	SSDUpdateReport	293	
12	6.5.2.143	StationClassMark	294	
13	6.5.2.144	SystemAccessData	295	
14	6.5.2.145	SystemAccessType	296	
15	6.5.2.146	SystemCapabilities	297	
16	6.5.2.147	SystemMyTypeCode	299	
17	6.5.2.148	TargetCellID	301	
18	6.5.2.149	TargetMeasurementInformation	302	
19	6.5.2.150	TargetMeasurementList	302	
20	6.5.2.151	TDMABurstIndicator	303	
21	6.5.2.152	TDMACallMode	304	
22	6.5.2.153	TDMACHannelData	305	
23	6.5.2.154	TerminalType	307	
24	6.5.2.155	TerminationAccessType	308	
25	6.5.2.156	TerminationList	309	
26	6.5.2.157	TerminationRestrictionCode	310	
27	6.5.2.158	TerminationTreatment	311	
28	6.5.2.159	TerminationTriggers	312	
29	6.5.2.160	TransactionCapability	315	
30	6.5.2.161	TrunkStatus	317	
31	6.5.2.162	UniqueChallengeReport	318	
32	6.5.2.163	UpdateCount	319	
33	6.5.2.164	VoiceMailboxNumber	320	
34	6.5.2.165	VoiceMailboxPIN	321	
35	6.5.2.166	VoicePrivacyMask	322	
36	6.5.2.J1	ChargingAreaInformation	325	*
37	6.5.2.J2	CarrierIdentificationCode	326	*
38	6.5.2.J3	MobileAdditionalParty'sCategory3	327	*
39	6.5.3	Parameter Type Definitions	323	
40	6.5.3.1.	CHOICE	323	
41	6.5.3.2.	DigitsType	323	
42	6.5.3.3.	ENUMERATED	327	
43	6.5.3.4.	IMPLICIT	327	
44	6.5.3.5.	INTEGER	329	
45	6.5.3.6.	NULL	329	
46	6.5.3.7.	OCTET STRING	329	
47	6.5.3.8.	SEQUENCE	329	
48	6.5.3.9.	SEQUENCE OF	330	
49				
50				
51				
52				
53				
54				
55				
56				
57				
58				
59				
60				

1
2
3
4
5
6
7
8
9
10
11
12
13
14
15
16
17
18
19
20
21
22
23
24
25
26
27
28
29
30
31
32
33
34
35
36
37
38
39
40
41
42
43
44
45
46
47
48
49
50
51
52
53
54
55
56
57
58
59
60

6.5.3.10.	SEQUENCE OF CHOICE	330
6.5.3.11.	SET	330
6.5.3.12.	SET OF CHOICE	330
6.5.3.13.	Subaddress.....	330
6.5.3.14.	Unsigned Enumerated	331
6.5.3.15.	Unsigned Integer.....	331
7	MAP COMPATIBILITY GUIDELINES AND RULES.....	332
7.1	ACHIEVING FORWARD COMPATIBILITY AND BACKWARD COMPATIBILITY.....	332
7.1.1	Forward Compatibility.....	332
7.1.2	Backward Compatibility.....	332
7.2	GUIDELINES FOR FORWARD COMPATIBILITY.....	332
7.3	GUIDELINES FOR BACKWARD COMPATIBILITY.....	334
7.3.1	Existing Messages	334
7.3.2	Parameters in Existing Messages.....	334
7.3.3	New Messages.....	335
7.3.4	New Parameters.....	335
7.3.5	New Parameter Fields.....	335
7.3.6	New Parameter Values.....	335

LIST OF FIGURES

Figure 1	MAP Protocol Architecture	3
Figure 2	OSI Reference Model Relationship.....	3
Figure 3	Application Services.....	4
Figure 4	SS7-based Data Transfer Services.....	4
Figure 5	X.25-based Data Transfer Services	5
Figure 6	Application Services Architecture.....	14
Figure 7	TIA/EIA-41 Application Layer Structure	15
Figure 8	AccessDeniedReason parameter	128
Figure 9	ActionCode parameter	129
Figure 10	AlertCode parameter	130
Figure 11	AlertResult parameter	132
Figure 12	AnnouncementCode parameter	133
Figure 13	AnnouncementList parameter	141
Figure 14	AuthenticationAlgorithmVersion parameter	142
Figure 15	AuthenticationCapability parameter	143
Figure 16	AuthenticationData parameter	144
Figure 17	AuthenticationResponse parameter	145
Figure 18	AuthenticationResponseBaseStation parameter	146
Figure 19	AuthenticationResponseUniqueChallenge parameter.....	146
Figure 20	AuthorizationDenied parameter	147
Figure 21	AuthorizationPeriod parameter	148
Figure 22	AvailabilityType parameter	149
Figure 23	BillingID parameter.....	150
Figure 24	BorderCellAccess parameter.....	151
Figure 25	CallHistoryCount parameter	152
Figure 26	CallHistoryCountExpected parameter	152
Figure 27	CallingFeaturesIndicator parameter	153
Figure 28	CallingPartyNumberDigits1 parameter for BCD digits	155
Figure 29	CallingPartyNumberDigits2 parameter for BCD digits	156
Figure 30	CallingPartyNumberString1 parameter for IA5 digits	157
Figure 31	CallingPartyNumberString2 parameter for IA5 digits	158
Figure 32	CallingPartySubaddress parameter	159
Figure 33	CancellationDenied parameter	160
Figure 34	CancellationType parameter	161
Figure 35	CarrierDigits parameter for BCD digits	162
Figure 36	CDMA Call Mode parameter.....	163
Figure 37	CDMA Channel Data parameter	164
Figure 38	CDMA Code Channel parameter	166
Figure 39	CDMA Code Channel Information parameter	166
Figure 40	CDMA Code Channel List parameter	167
Figure 41	CDMA Mobile Protocol Revision parameter.....	167
Figure 42	CDMA Pilot Strength parameter	168
Figure 43	CDMA Private Long Code Mask parameter.....	169
Figure 44	CDMA Search Window parameter	170
Figure 45	CDMA Serving One Way Delay parameter.....	170
Figure 46	CDMA Signal Quality parameter	171

1	Figure 47	CDMASlotCycleIndex parameter.....	171
2	Figure 48	CDMAStationClassMark parameter	172
3	Figure 49	CDMATargetMAHOInformation parameter.....	173
4	Figure 50	CDMATargetMAHOList parameter.....	173
5	Figure 51	CDMATargetMeasurementInformation parameter	174
6	Figure 52	CDMATargetMeasurementList parameter	174
7	Figure 53	CDMATargetOneWayDelay parameter.....	175
8	Figure 54	ChannelData parameter	176
9	Figure 55	ConditionallyDeniedReason parameter.....	177
10	Figure 56	ConferenceCallingIndicator parameter	178
11	Figure 57	ConfidentialityModes parameter	179
12	Figure 58	ControlChannelData parameter	180
13	Figure 59	CountUpdateReport parameter.....	181
14	Figure 60	DeniedAuthorizationPeriod parameter	182
15	Figure 61	DenyAccess parameter.....	183
16	Figure 62	DeregistrationType parameter	184
17	Figure 63	DestinationDigits parameter for BCD digits	185
18	Figure 64	DigitCollectionControl parameter	186
19	Figure 65	Format of DigitMask	187
20	Figure 66	Digits parameter for BCD digits.....	189
21	Figure 67	DMH_AccountCodeDigits parameter for BCD digits.....	191
22	Figure 68	DMH_AlternateBillingDigits parameter for BCD digits	192
23	Figure 69	DMH_BillingDigits parameter for BCD digits.....	193
24	Figure 70	DMH_RedirectionIndicator parameter	194
25	Figure 71	ElectronicSerialNumber parameter	196
26	Figure 72	ExtendedMSCID parameter	197
27	Figure 73	ExtendedSystemMyTypeCode parameter.....	198
28	Figure 74	FaultyParameter parameter.....	199
29	Figure 75	FeatureResult parameter.....	200
30	Figure 76	GeographicAuthorization parameter	201
31	Figure 77	GroupInformation parameter	202
32	Figure 78	HandoffReason parameter.....	203
33	Figure 79	HandoffState parameter	204
34	Figure 80	InterMSCCircuitID parameter	204
35	Figure 81	InterSwitchCount parameter	205
36	Figure 82	IntersystemTermination parameter	206
37	Figure 83	LegInformation parameter.....	207
38	Figure 84	LocalTermination parameter	208
39	Figure 85	LocationAreaID parameter.....	209
40	Figure 86	MessageWaitingNotificationCount parameter.....	210
41	Figure 87	MessageWaitingNotificationType parameter.....	211
42	Figure 88	MobileDirectoryNumber parameter for BCD digits	212
43	Figure 89	MobileIdentificationNumber parameter.....	213
44	Figure 90	MSCID parameter.....	214
45	Figure 91	MSCIdentificationNumber parameter for BCD digits	215
46	Figure 92	MSLocation parameter.....	216
47	Figure 93	NAMPSCallMode parameter	217
48	Figure 94	NAMPSCChannelData parameter	218
49	Figure 95	NoAnswerTime parameter	219

1	Figure 96	OneTimeFeatureIndicator parameter	220
2	Figure 97	OriginationIndicator parameter	222
3	Figure 98	OriginationTriggers parameter	223
4	Figure 99	PACAIndicator parameter	228
5	Figure 100	PageIndicator parameter	229
6	Figure 101	PC_SSN parameter	230
7	Figure 102	PilotBillingID parameter.....	231
8	Figure 103	PilotNumber parameter for BCD digits	232
9	Figure 104	PreferredLanguageIndicator parameter	233
10	Figure 105	Profile Macro	234
11	Figure 106	PSTNTermination parameter	236
12	Figure 107	QualificationInformationCode parameter	237
13	Figure 108	RANDC parameter.....	238
14	Figure 109	RandomVariable parameter	239
15	Figure 110	RandomVariableBaseStation parameter	239
16	Figure 111	RandomVariableSSD parameter	240
17	Figure 112	RandomVariableUniqueChallenge parameter	240
18	Figure 113	RANDValidTime parameter	241
19	Figure 114	ReceivedSignalQuality parameter	241
20	Figure 115	RedirectingNumberDigits parameter for BCD digits	242
21	Figure 116	RedirectingNumberString parameter for IA5 digits	243
22	Figure 117	RedirectingSubaddress parameter	244
23	Figure 118	RedirectionReason parameter	245
24	Figure 119	ReleaseReason parameter	246
25	Figure 120	ReportType parameter	247
26	Figure 121	RestrictionDigits parameter for BCD digits	248
27	Figure 122	RoutingDigits parameter for BCD digits	249
28	Figure 123	SeizureType parameter.....	250
29	Figure 124	SenderIdentificationNumber parameter for BCD digits	251
30	Figure 125	ServingCellID parameter	252
31	Figure 126	SetupResult parameter	252
32	Figure 127	SharedSecretData parameter	253
33	Figure 128	SignalingMessageEncryptionKey parameter	253
34	Figure 129	SignalQuality parameter	254
35	Figure 130	Definition of Signal Quality for Handoff.....	255
36	Figure 131	SMS_AccessDeniedReason parameter.....	256
37	Figure 132	SMS_Address parameter for BCD digits.....	258
38	Figure 133	SMS_Address Encoding for an IP address	259
39	Figure 134	SMS_Address parameter for an ANSI SS7 Point Code Address	260
40	Figure 135	SMS_BearerData parameter	260
41	Figure 136	SMS_CauseCode parameter	262
42	Figure 137	SMS_ChargeIndicator parameter	267
43	Figure 138	SMS_DestinationAddress parameter for BCD digits	268
44	Figure 139	SMS_DestinationAddress parameter for an IP Address	269
45	Figure 140	SMS_MessageCount parameter	270
46	Figure 141	SMS_MessageWaitingIndicator parameter.....	270
47	Figure 142	SMS_NotificationIndicator parameter.....	271
48	Figure 143	SMS_OriginalDestinationAddress parameter for BCD digits	272
49	Figure 144	SMS_OriginalDestinationAddress parameter for IA5 digits	273

1	Figure 145	SMS_OriginalDestinationAddress parameter for an IP address	274	
2	Figure 146	SMS_OriginalDestinationSubaddress parameter	275	
3	Figure 147	SMS_OriginalOriginatingAddress parameter for BCD Digits	276	
4	Figure 148	SMS_OriginalOriginatingAddress parameter for IA5 digits	277	
5	Figure 149	SMS_OriginalOriginatingAddress parameter for an IP Address	278	
6	Figure 150	SMS_OriginalOriginatingSubaddress parameter	279	
7	Figure 151	SMS_OriginatingAddress parameter for BCD digits	280	
8	Figure 152	SMS_OriginatingAddress parameter for an IP Address	281	
9	Figure 153	SMS_OriginationRestrictions parameter	282	
10	Figure 154	SMS_TeleserviceIdentifier parameter.....	283	
11	Figure 155	SMS_TerminationRestrictions parameter	285	
12	Figure 156	SPINIPIN parameter	286	
13	Figure 157	SPINITriggers parameter	287	
14	Figure 158	SSDNotShared parameter	292	
15	Figure 159	SSDUpdateReport parameter	293	
16	Figure 160	StationClassMark parameter	294	
17	Figure 161	SystemAccessData parameter.....	295	
18	Figure 162	SystemAccessType parameter.....	296	
19	Figure 163	SystemCapabilities parameter	297	
20	Figure 164	SystemMyTypeCode parameter.....	299	
21	Figure 165	TargetCellID parameter	301	
22	Figure 166	TargetMeasurementInformation parameter	302	
23	Figure 167	TargetMeasurementList parameter	302	
24	Figure 168	TDMA BurstIndicator parameter.....	303	
25	Figure 169	TDMA CallMode parameter	304	
26	Figure 170	TDMA ChannelData parameter	305	
27	Figure 171	TerminalType parameter	307	
28	Figure 172	TerminationAccessType parameter	308	
29	Figure 173	TerminationList parameter	309	
30	Figure 174	TerminationRestrictionCode parameter	310	
31	Figure 175	TerminationTreatment parameter	311	
32	Figure 176	TerminationTriggers param eter.....	312	
33	Figure 177	TransactionCapability parameter	315	
34	Figure 178	TrunkStatus parameter	317	
35	Figure 179	UniqueChallengeReport parameter.....	318	
36	Figure 180	UpdateCount parameter	319	
37	Figure 181	VoiceMailboxNumber parameter for BCD digits.....	320	
38	Figure 182	VoiceMailboxPIN parameter for BCD digits.....	321	
39	Figure 183	VoicePrivacyMask parameter.....	322	
40	Figure 184	DigitsType parameter type variant for BCD digits	323	
41	Figure 185	DigitsType parameter type variant for IA5 digits	324	
42	Figure 186	DigitsType parameter type variant for IP address.....	324	
43	Figure 187	DigitsType parameter type variant for an ANSI SS7 point code address	325	
44	Figure 188	InterSwitchCount parameter (IMPLICIT encoding)	327	
45	Figure 189	InterSwitchCount parameter (EXPLICIT encoding)	328	
46	Figure 190	Subaddress parameter type.....	330	
47	Figure J1	ChargingAreaInformation parameter	325	*
48	Figure J2	CarrierIdentificationCode parameter	326	*

1
2
3
4
5
6
7
8
9
10
11
12
13
14
15
16
17
18
19
20
21
22
23
24
25
26
27
28
29
30
31
32
33
34
35
36
37
38
39
40
41
42
43
44
45
46
47
48
49
50
51
52
53
54
55
56
57
58
59
60

Figure J3	MobileAdditionalParty’sCategory3 parameter.....	327	*
-----------	---	-----	---

LIST OF TABLES

Table 1	MTP Message Priority Values for TIA/EIA-41 Operations	6
Table 2	Structure of TCAP Package with INVOKE Component.....	17
Table 3	Structure of TCAP Package with RETURN RESULT Component.....	17
Table 4	Structure of TCAP Package with RETURN ERROR Component.....	18
Table 5	RETURN ERROR Parameters.....	19
Table 6	Error Codes	22
Table 7	Structure of TCAP Package with REJECT Component.....	23
Table 8	TIA/EIA-41 MAP Operation Specifiers.....	24
Table 9	Mapping of TIA/EIA-41 Operations onto TCAP Package Types.....	26
Table 10	Summary of MAP Operations	27
Table 11	AuthenticationDirective INVOKE Parameters	29
Table 12	AuthenticationDirective RETURN RESULT Parameters.....	30
Table 13	AuthenticationDirectiveForward INVOKE Parameters	31
Table 14	AuthenticationDirectiveForward RETURN RESULT Parameters.....	31
Table 15	AuthenticationFailureReport INVOKE Parameters	32
Table 16	AuthenticationFailureReport RETURN RESULT Parameters.....	33
Table 17	AuthenticationRequest INVOKE Parameters.....	34
Table 18	AuthenticationRequest RETURN RESULT Parameters.....	35
Table 19	AuthenticationStatusReport INVOKE Parameters	36
Table 20	AuthenticationStatusReport RETURN RESULT Parameters	37
Table 21	BaseStationChallenge INVOKE Parameters	38
Table 22	BaseStationChallenge RETURN RESULT Parameters.....	38
Table 23	Blocking INVOKE Parameters.....	39
Table 24	Blocking RETURN RESULT Parameters.....	39
Table 25	BulkDeregistration INVOKE Parameters	40
Table 26	BulkDeregistration RETURN RESULT Parameters	40
Table 27	CountRequest INVOKE Parameters	41
Table 28	CountRequest RETURN RESULT Parameters.....	41
Table 29	FacilitiesDirective INVOKE Parameters	42
Table 30	FacilitiesDirective RETURN RESULT Parameters.....	43
Table 31	FacilitiesDirective2 INVOKE Parameters.....	44
Table 32	FacilitiesDirective2 RETURN RESULT Parameters.....	46
Table 33	FacilitiesRelease INVOKE Parameters.....	47
Table 34	FacilitiesRelease RETURN RESULT Parameters.....	47
Table 35	FeatureRequest INVOKE Parameters.....	48
Table 36	FeatureRequest RETURN RESULT Parameters.....	50
Table 37	FlashRequest INVOKE Parameters	52
Table 38	FlashRequest RETURN RESULT Parameters.....	52
Table 39	HandoffBack INVOKE Parameters.....	53
Table 40	HandoffBack RETURN RESULT Parameters.....	54
Table 41	HandoffBack2 INVOKE Parameters.....	55
Table 42	HandoffBack2 RETURN RESULT Parameters.....	57
Table 43	HandoffMeasurementRequest INVOKE Parameters.....	58
Table 44	HandoffMeasurementRequest RETURN RESULT Parameters.....	58
Table 45	HandoffMeasurementRequest2 INVOKE Parameters.....	59

1	Table 46	HandoffMeasurementRequest2 RETURN RESULT Parameters.....	60
2	Table 47	HandoffToThird INVOKE Parameters.....	61
3	Table 48	HandoffToThird RETURN RESULT Parameters.....	62
4	Table 49	HandoffToThird2 INVOKE Parameters.....	63
5	Table 50	HandoffToThird2 RETURN RESULT Parameters.....	65
6	Table 51	InformationDirective INVOKE Parameters.....	66
7	Table 52	InformationDirective RETURN RESULT Parameters.....	67
8	Table 53	InformationForward INVOKE Parameters.....	68
9	Table 54	InformationForward RETURN RESULT Parameters.....	68
10	Table 55	InterSystemAnswer INVOKE Parameters.....	70
11	Table 56	InterSystemAnswer RETURN RESULT Parameters.....	70
12	Table 57	InterSystemPage INVOKE Parameters.....	72
13	Table 58	InterSystemPage RETURN RESULT Parameters.....	73
14	Table 59	InterSystemPage2 INVOKE Parameters.....	74
15	Table 60	InterSystemPage2 RETURN RESULT Parameters.....	75
16	Table 61	InterSystemSetup INVOKE Parameters.....	76
17	Table 62	InterSystemSetup RETURN RESULT Parameters.....	76
18	Table 63	LocationRequest INVOKE Parameters.....	77
19	Table 64	LocationRequest RETURN RESULT Parameters.....	78
20	Table 65	MobileOnChannel INVOKE Parameters.....	79
21	Table 66	MSInactive INVOKE Parameters.....	80
22	Table 67	MSInactive RETURN RESULT Parameters.....	80
23	Table 68	OriginationRequest INVOKE Parameters.....	81
24	Table 69	OriginationRequest RETURN RESULT Parameters.....	82
25	Table 70	QualificationDirective INVOKE Parameters.....	84
26	Table 71	QualificationDirective RETURN RESULT Parameters.....	85
27	Table 72	QualificationRequest INVOKE Parameters.....	86
28	Table 73	QualificationRequest RETURN RESULT Parameters.....	87
29	Table 74	RandomVariableRequest INVOKE Parameters.....	88
30	Table 75	RandomVariableRequest RETURN RESULT Parameters.....	88
31	Table 76	RedirectionDirective INVOKE Parameters.....	89
32	Table 77	RedirectionDirective RETURN RESULT Parameters.....	90
33	Table 78	RedirectionRequest INVOKE Parameters.....	91
34	Table 79	RedirectionRequest RETURN RESULT Parameters.....	91
35	Table 80	RegistrationCancellation INVOKE Parameters.....	92
36	Table 81	RegistrationCancellation RETURN RESULT Parameters.....	93
37	Table 82	RegistrationNotification INVOKE Parameters.....	94
38	Table 83	RegistrationNotification RETURN RESULT Parameters.....	96
39	Table 84	RemoteUserInteractionDirective INVOKE Parameters.....	97
40	Table 85	RemoteUserInteractionDirective RETURN RESULT Parameters.....	97
41	Table 86	ResetCircuit INVOKE Parameters.....	98
42	Table 87	ResetCircuit RETURN RESULT Parameters.....	98
43	Table 88	RoutingRequest INVOKE Parameters.....	99
44	Table 89	RoutingRequest RETURN RESULT Parameters.....	101
45	Table 90	SMSDeliveryBackward INVOKE Parameters.....	102
46	Table 91	SMSDeliveryBackward RETURN RESULT Parameters.....	103
47	Table 92	SMSDeliveryForward INVOKE Parameters.....	104
48	Table 93	SMSDeliveryForward RETURN RESULT Parameters.....	105

1	Table 94	SMSDeliveryPointToPoint INVOKE Parameters	106
2	Table 95	SMSDeliveryPointToPoint RETURN RESULT Parameters.....	107
3	Table 96	SMSNotification INVOKE Parameters.....	108
4	Table 97	SMSNotification RETURN RESULT Parameters.....	108
5	Table 98	SMSRequest INVOKE Parameters.....	109
6	Table 99	SMSRequest RETURN RESULT Parameters.....	109
7	Table 100	TransferToNumberRequest INVOKE Parameters.....	110
8	Table 101	TransferToNumberRequest RETURN RESULT Parameters.....	111
9	Table 102	TrunkTest INVOKE Parameters.....	113
10	Table 103	TrunkTest RETURN RESULT Parameters.....	113
11	Table 104	TrunkTestDisconnect INVOKE Parameters.....	114
12	Table 105	TrunkTestDisconnect RETURN RESULT Parameters.....	114
13	Table 106	Unblocking INVOKE Parameters.....	115
14	Table 107	Unblocking RETURN RESULT Parameters.....	115
15	Table 108	UnreliableRoamerDataDirective INVOKE Parameters	116
16	Table 109	UnreliableRoamerDataDirective RETURN RESULT Parameters.....	116
17	Table 110	UnsolicitedResponse INVOKE Parameters	117
18	Table 111	UnsolicitedResponse RETURN RESULT Parameters.....	118
19	Table 112	TIA/EIA-41 MAP Parameter Identifiers	119
20	Table 113	AccessDeniedReason value.....	128
21	Table 114	ActionCode value	129
22	Table 115	AlertCode Value.....	130
23	Table 116	AlertResult value	132
24	Table 117	AnnouncementCode value	134
25	Table 118	Authentication Algorithm Version value	142
26	Table 119	AuthenticationCapability value	143
27	Table 120	AuthorizationDenied Reason value	147
28	Table 121	AuthorizationPeriod value.....	148
29	Table 122	AvailabilityType value.....	149
30	Table 123	BillingID value.....	150
31	Table 124	BorderCellAccess value.....	151
32	Table 125	CallingFeaturesIndicator value	154
33	Table 126	CancellationDenied value	160
34	Table 127	CancellationType value.....	161
35	Table 128	CDMACallMode value.....	163
36	Table 129	CDMAChannelData value	165
37	Table 130	CDMAStationClassMark value.....	172
38	Table 131	ChannelData value	176
39	Table 132	ConditionallyDeniedReason value.....	177
40	Table 133	ConferenceCallingIndicator value	178
41	Table 134	ConfidentialityModes value	179
42	Table 135	CountUpdateReport value.....	181
43	Table 136	DeniedAuthorizationPeriod value.....	182
44	Table 137	DenyAccess Reason value.....	183
45	Table 138	DeregistrationType value	184
46	Table 139	DigitCollectionControl value	188
47	Table 140	DMH_RedirectionIndicator value	194
48	Table 141	ExtendedMSCID value	197
49			
50			
51			
52			
53			
54			
55			
56			
57			
58			
59			
60			

1	Table 142	ExtendedSystemMyTypeCode value.....	198
2	Table 143	FeatureResult value.....	200
3	Table 144	GeographicAuthorization value.....	201
4	Table 145	HandoffReason value.....	203
5	Table 146	HandoffState value.....	204
6	Table 147	MessageWaitingNotificationCount value.....	210
7	Table 148	MessageWaitingNotificationType value.....	211
8	Table 149	MobileIdentificationNumber value.....	213
9	Table 150	NAMPSCallMode value.....	217
10	Table 151	NAMPSChannelData value.....	218
11	Table 152	NoAnswerTime value.....	219
12	Table 153	OneTimeFeatureIndicator value.....	220
13	Table 154	OriginationIndicator value.....	222
14	Table 155	OriginationTriggers value.....	223
15	Table 156	PACAIndicator value.....	228
16	Table 157	PageIndicator value.....	229
17	Table 158	PC_SSN value.....	230
18	Table 159	PilotBillingID value.....	231
19	Table 160	PreferredLanguageIndicator value.....	233
20	Table 161	QualificationInformationCode value.....	237
21	Table 162	RANDC value.....	238
22	Table 163	RANDValidTime value.....	241
23	Table 164	RedirectionReason value.....	245
24	Table 165	ReleaseReason value.....	246
25	Table 166	ReportType value.....	247
26	Table 167	SeizureType parameter.....	250
27	Table 168	SetupResult value.....	252
28	Table 169	SignalQuality value.....	254
29	Table 170	SMS Access Denied Reason value.....	256
30	Table 171	SMS_CauseCode value.....	263
31	Table 172	SMS Charge Indicator values.....	267
32	Table 173	SMS_NotificationIndicator value.....	271
33	Table 174	SMS_OriginationRestrictions value.....	282
34	Table 175	SMS_Teleservice Identifier values.....	284
35	Table 176	SMS_TerminationRestrictions value.....	285
36	Table 177	SPINITriggers value.....	287
37	Table 178	SSDNotShared value.....	292
38	Table 179	SSDUpdateReport value.....	293
39	Table 180	StationClassMark value.....	294
40	Table 181	SystemAccessType value.....	296
41	Table 182	SystemCapabilities value.....	298
42	Table 183	SystemMyTypeCode value.....	300
43	Table 184	TDMA BurstIndicator value.....	303
44	Table 185	TDMA CallMode value.....	304
45	Table 186	TDMA ChannelData value.....	306
46	Table 187	TerminalType value.....	307
47	Table 188	TerminationAccessType value.....	308
48	Table 189	TerminationRestrictionCode parameter.....	310

1	Table 190	TerminationTreatment parameter	311	
2	Table 191	TerminationTriggers value	312	
3	Table 192	TransactionCapability parameter	316	
4	Table 193	TrunkStatus value	317	
5	Table 194	UniqueChallengeReport value.....	318	
6	Table 195	UpdateCount value	319	
7	Table 196	DigitsType value.....	325	
8	Table 197	IMPLICIT Encoding of InterSwitchCount.....	328	
9	Table 198	EXPLICIT Encoding of InterSwitchCount	328	
10	Table 199	Subaddress value	331	
11	Table 200	Forward Compatibility Guidelines for Handling Incoming		
12		Messages and Parameters.....	333	
13	Table J1	ChargingAreaInformation value	325	*
14	Table J2	CarrierIdentificationCode value	326	*
15	Table J3	MobileAdditionalParty'sCategory3 value.....	327	*
16				
17				
18				
19				
20				
21				
22				
23				
24				
25				
26				
27				
28				
29				
30				
31				
32				
33				
34				
35				
36				
37				
38				
39				
40				
41				
42				
43				
44				
45				
46				
47				
48				
49				
50				
51				
52				
53				
54				
55				
56				
57				
58				
59				
60				

FOREWORD

This foreword is not part of this Standard.

This is one of a series of recommendations entitled:

“Cellular Radiotelecommunications Intersystem Operations”

which describe procedures necessary to provide to cellular radio telephone subscribers certain services requiring interaction between different cellular systems.

It is the intention of TIA/EIA TR-45.2 Subcommittee, Intersystem Operations, that this series of recommendations address the ongoing and developing concerns of the Cellular Radiotelecommunications Industry— subscribers, service providers and manufacturers alike— with regard to useful and effective services requiring standardized intersystem procedures.

The recommendations included in this series are:

- Chapter 1, *Cellular Radiotelecommunications Intersystem Operations: Functional Overview*
- Chapter 2, *Cellular Radiotelecommunications Intersystem Operations: Intersystem Handoff Information Flows*
- Chapter 3, *Cellular Radiotelecommunications Intersystem Operations: Automatic Roaming Information Flows*
- Chapter 4, *Cellular Radiotelecommunications Intersystem Operations: Operations, Administration, and Maintenance Information Flows*
- Chapter 5, *Cellular Radiotelecommunications Intersystem Operations: Signaling Protocols*
- Chapter 6, *Cellular Radiotelecommunications Intersystem Operations: Signaling Procedures*

This edition of the Standard replaces *IS-41-C* which differs from the previous edition (i.e., *IS-41-B*) in its support of the following functionality:

- Intersystem Authentication and Encryption (supersedes *TSB51*)
- Intersystem Operations for Dual-mode CDMA Terminals (supersedes *TSB64*)
- Border Cell Problem Resolution (supersedes *TSB65*)
- Expanded Feature Support (i.e., for features defined in *TIA/EIA-664*)
- Technical Clarifications and Compatibility (as per *TSB41* and *TSB55*)

The following pre-*IS-41-C* operation and parameter names have been changed in this revision of *IS-41* (O = operation, P = parameter):

pre- IS-41-C Name	IS-41-C Name
CSSInactive (O)	MSInactive
RemoteFeatureControlRequest (O)	FeatureRequest
CallMode (P)	TDMACallMode
CSSLocation (P)	MSLocation
DigitalChannelData (P)	TDMACHannelData
FeatureIdentifier (P)	RedirectionReason
MobileSerialNumber (P)	ElectronicSerialNumber
MOB_P_REV (P)	CDMAMobileProtocolRevision
PrivateLongCodeMask (P)	CDMAPrivateLongCodeMask
RemoteFeatureOperationResult (P)	FeatureResult
SearchWindow (P)	CDMASearchWindow
SecurityStatusReport (O)	AuthenticationFailureReport
ServingOneWayDelay (P)	CDMAServingOneWayDelay
ShortenedBurstIndicator (P)	TDMABurstIndicator
SlotCycleIndex (P)	CDMASlotCycleIndex
SystemID	MarketID
TargetOneWayDelay (P)	CDMATargetOneWayDelay

Also, the following new operations have been added in this revision of *IS-41* :

Operation Name	Operation Name
AuthenticationDirective	InterSystemAnswer
AuthenticationDirectiveForward	InterSystemPage
AuthenticationFailureReport	InterSystemPage2
AuthenticationRequest	InterSystemSetup
AuthenticationStatusReport	OriginationRequest
BaseStationChallenge	RandomVariableRequest
BulkDeregistration	RedirectionDirective
CountRequest	RemoteUserInteractionDirective
FacilitiesDirective2	SMSDeliveryBackward
HandoffBack2	SMSDeliveryForward
HandoffMeasurementRequest2	SMSDeliveryPointToPoint
HandoffToThird2	SMSNotification
InformationDirective	SMSRequest
InformationForward	UnsolicitedResponse

Finally, the following new parameters have been added in this revision of *IS-41* :

Parameter Name	Parameter Name
ActionCode	CDMATargetMeasurementList
AlertCode	CDMATargetOneWayDelay
AlertResult	ConditionallyDeniedReason
AnnouncementCode	ConferenceCallingIndicator
AnnouncementList	ConfidentialityModes
AuthenticationAlgorithmVersion	ControlChannelData
AuthenticationCapability	CountUpdateReport
AuthenticationResponse	DenyAccess
AuthenticationResponseBaseStation	DeregistrationType
AuthenticationResponseUnique-Challenge	DestinationDigits
AvailabilityType	DigitCollectionControl
BorderCellAccess	DMH_AccountCodeDigits
CallHistoryCount	DMH_AlternateBillingDigits
CallHistoryCountExpected	DMH_BillingDigits
CallingPartyNumberDigits1	DMH_RedirectionIndicator
CallingPartyNumberDigits2	ExtendedMSCID
CallingPartyNumberString1	ExtendedSystemMyTypeCode
CallingPartyNumberString2	GeographicAuthorization
CallingPartySubaddress	IntersystemTermination
CancellationDenied	LegInformation
CancellationType	LocalTermination
CarrierDigits	MessageWaitingNotificationCount
CDMACallMode	MessageWaitingNotificationType
CDMAChannelData	MobileDirectoryNumber
CDMACodeChannel	MSCIdentificationNumber
CDMACodeChannelInformation	MSLocation
CDMACodeChannelList	NAMPSCChannelData
CDMAMobileProtocolRevision	NoAnswerTime
CDMAPilotStrength	OneTimeFeatureIndicator
CDMAPrivateLongCodeMask	OriginationTriggers
CDMASearchWindow	PACAIndicator
CDMAServingOneWayDelay	PageIndicator
CDMASignalQuality	PilotBillingID
CDMASlotCycleIndex	PilotNumber
CDMAStationClassMark	PreferredLanguageIndicator
CDMATargetMAHOInformation	PSTNTermination
CDMATargetMAHOList	RANDC
CDMATargetMeasurementInformation	RandomVariable

1
2
3
4
5
6
7
8
9
10
11
12
13
14
15
16
17
18
19
20
21
22
23
24
25
26
27
28
29
30
31
32
33
34
35
36
37
38
39
40
41
42
43
44
45
46
47
48
49
50
51
52
53
54
55
56
57
58
59
60

Parameter Name
RandomVariableBaseStation
RandomVariableSSD
RandomVariableUniqueChallenge
RANDValidTime
ReceivedSignalQuality
RedirectingNumberDigits
RedirectingNumberString
RedirectingSubaddress
ReportType
RestrictionDigits
RoutingDigits
SenderIdentificationNumber
SetupResult
SharedSecretData
SignalingMessageEncryptionKey
SMS_AccessDeniedReason
SMS_Address
SMS_BearerData
SMS_CauseCode
SMS_ChargeIndicator
SMS_DestinationAddress
SMS_MessageCount
SMS_MessageWaitingIndicator
SMS_NotificationIndicator
SMS_OriginalDestinationAddress

Parameter Name
SMS_OriginalDestinationSubaddress
SMS_OriginalOriginatingAddress
SMS_OriginalOriginatingSubaddress
SMS_OriginatingAddress
SMS_OriginationRestrictions
SMS_TeleserviceIdentifier
SMS_TerminationRestrictions
SSDNotShared
SSDUpdateReport
SystemAccessData
SystemAccessType
SystemCapabilities
TargetMeasurementInformation
TargetMeasurementList
TerminalType
TerminationAccessType
TerminationList
TerminationTreatment
TerminationTriggers
TransactionCapability
UniqueChallengeReport
UpdateCount
VoiceMailboxNumber
VoiceMailboxPIN
VoicePrivacyMask

REVISION HISTORY

Revision	Date	Remarks
<i>(IS-41)0</i>	February 1988	Initial publication
<i>(IS-41)A</i>	January 1991	
<i>(IS-41)B</i>	December 1991	
<i>(IS-41)C</i>	February 1996	
D	December 1997	Initial ANSI publication

NOTE

The numbering system of this series of Standards varies from normal TIA/EIA practice. The unique numbering system assigned to these documents is intended to reflect their hierarchical structure.

1
2
3
4
5
6
7
8
9
10
11
12
13
14
15
16
17
18
19
20
21
22
23
24
25
26
27
28
29
30
31
32
33
34
35
36
37
38
39
40
41
42
43
44
45
46
47
48
49
50
51
52
53
54
55
56
57
58
59
60

(This page intentionally left blank.)

1 INTRODUCTION

1.1 OBJECTIVE

This part deals with the protocols required for the support of the capabilities identified in the other parts of the Standard.

The protocols used to support roaming cellular radio subscribers must be standardized so that with a minimum of pre-coordination two mobile systems can communicate. However, this protocol hierarchy must satisfy evolving telecommunication industry signaling needs. Conflicting demands for (1) standardization and (2) variety are accommodated by including negotiation and network selection (i.e., SS7 or X.25) capabilities within the protocol hierarchy.

1.2 SCOPE

This part of the Standard defines the protocol suite used to provide to cellular radio telephone subscribers certain services requiring interaction between different cellular systems. These services are described, from a user's perspective, in [TIA/EIA-664]. The intersystem operations' functions and information flows associated with these services are described in the other parts of this Standard.

Specifically, the scope of this part of the Standard is:

1. To define the Mobile Application Part (MAP) signaling messages and parameters which support the intersystem operations functionality specified in the other parts of this Standard. This includes:
 - the Intersystem Handoff functionality specified in Chapter 2,
 - the Automatic Roaming functionality specified in Chapter 3, and
 - the Intersystem OA&M functionality specified in Chapter 4

The procedures associated with the processing of MAP signaling information are specified in Chapter 6.

2. To provide references to, and qualifications on, the service and protocol standards which are recommended in this Standard for the support of the MAP.

1.3 ORGANIZATION

This document is organized as follows:

- Section 1, entitled “Introduction,” provides introductory information for this part of the Standard.
- Section 2, entitled “References,” lists the normative and informative references for this Standard.
- Section 3, entitled “Terminology,” lists the definitions, symbols, abbreviations, and other documentation conventions used in this Standard.
- Section 4, entitled “MAP Protocol Architecture,” summarizes the protocol architecture employed in this Standard.
- Section 5, entitled “Data Transfer Services,” specifies the data transfer services provided for the use of the MAP Application Services and the protocols used to provide these data transfer services.
- Section 6, entitled “Application Services,” specifies the information transfer services provided for the purposes of MAP Intersystem Operations. This includes a description of the Application Layer structure, the requirements on *ANSI Transaction Capabilities Application Part (TCAP)* formats and procedures, and the formats and encoding of the signaling information comprising the MAP.
- Section 7, entitled “MAP Compatibility Guidelines and Rules,” provides guidelines and rules for forward and backward compatibility.

2 REFERENCES

Refer to Chapter 1.

3 TERMINOLOGY

3.1 DEFINITION

Refer to Chapter 1.

3.2 SYMBOLS AND ABBREVIATIONS

Refer to Chapter 1.

4 MAP PROTOCOL ARCHITECTURE

The following figure provides a high-level view of the MAP Protocol Architecture.

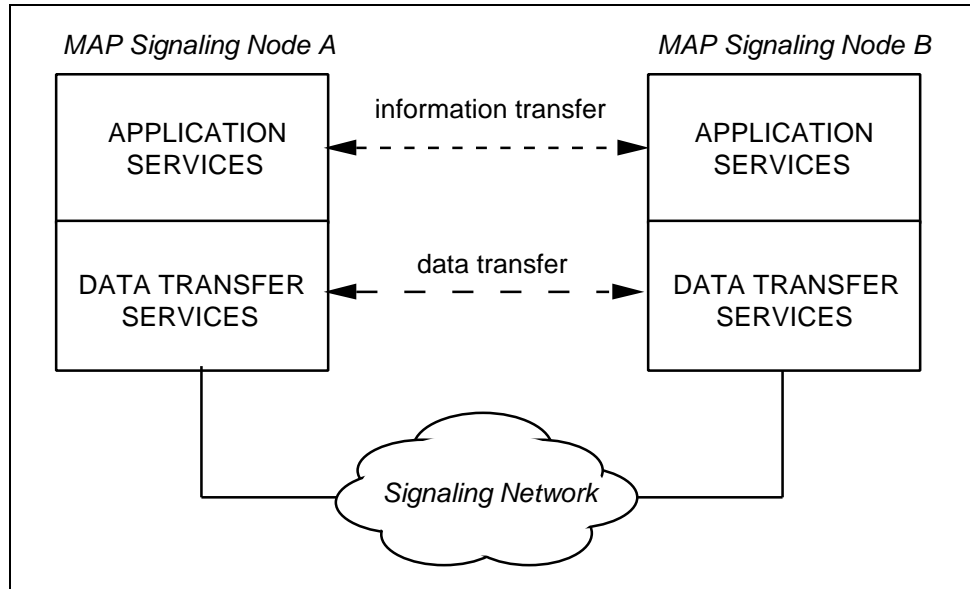

Figure 1 MAP Protocol Architecture

The fundamental division within the architecture is between *data transfer services* and *application services*. Application services deal with the transfer of *information*, with its associated syntax and semantics. Data transfer services simply move octets between MAP functional entities via a signaling network.

In terms of the Open Systems Interconnection (OSI) Reference Model, defined in the *CCITT X.200* series of recommendations, Application Services encompass the Application, Presentation, Session, and Transport layers. Data Transfer Services cover the Network, Data Link, and Physical layers of the model (see Figure 2).

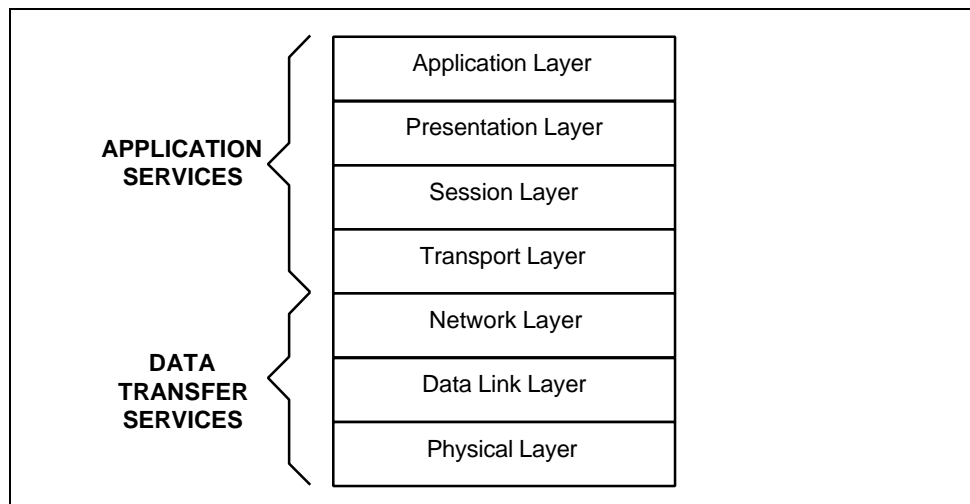

Figure 2 OSI Reference Model Relationship

This Standard specifies a single set of Application Services (see Figure 3) comprised of the *ANSI* Transaction Capabilities specified in *ANSI T1.114*, along with *TIA/EIA-41* application-specific services called the Mobile Application Part (MAP). These services are defined in Section 6, including the qualifications, limitations and exceptions on the use of *ANSI T1.114* in this Standard.

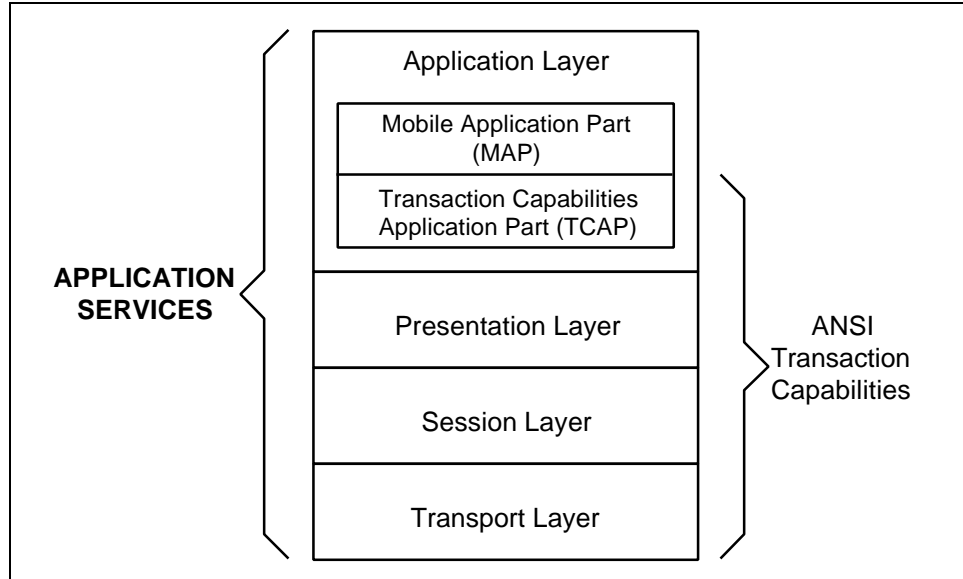

Figure 3 Application Services

A choice of two sets of Data Transfer Services is allowed in this Standard.

One set is *SS7*-based and is comprised of the *ANSI SS7* Signaling Connection Control Part (SCCP) plus Message Transfer Part (MTP) specified in *ANSI T1.112* and *ANSI T1.111*, respectively (see Figure 4). The qualifications, limitations and exceptions on the use of these standards in *TIA/EIA-41* are specified in Section 5.1.

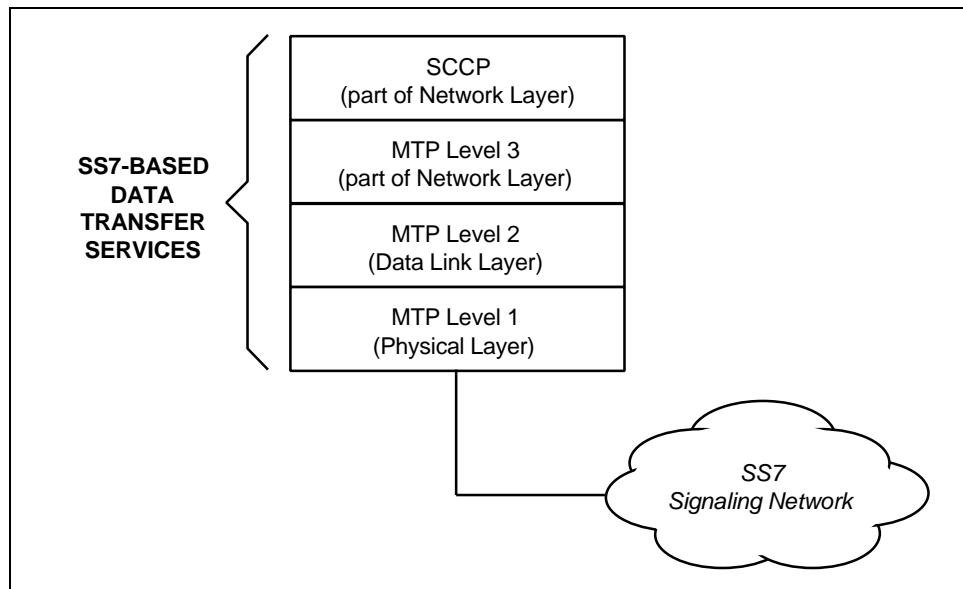
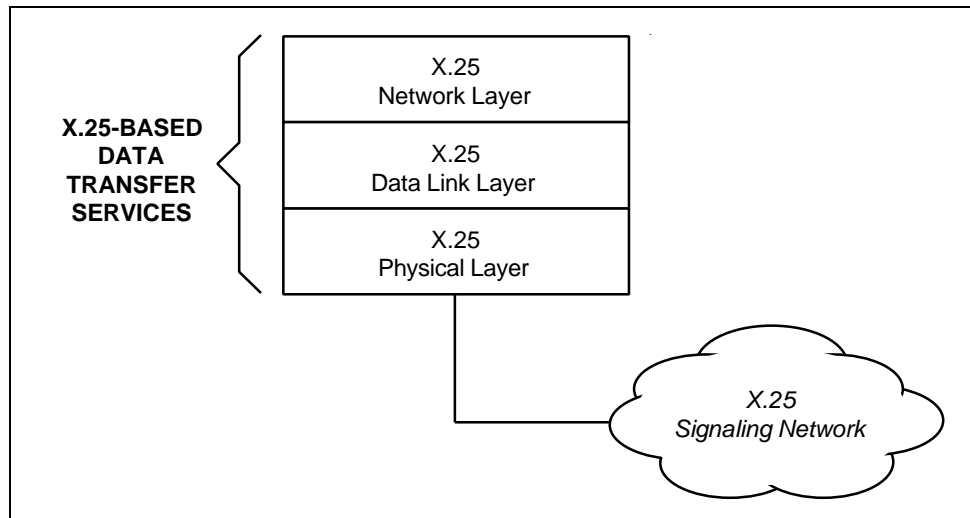

Figure 4 SS7-based Data Transfer Services

1 The other alternative is based on the X.25 data communications standard (see Figure 5).
2 The relevant X.25 standards, as well as the qualifications, limitations and exceptions on
3 the use of these standards in *TIA/EIA-41*, are specified in Section 5.2.
4



23 **Figure 5 X.25-based Data Transfer Services**
24
25
26
27
28
29
30
31
32
33
34
35
36
37
38
39
40
41
42
43
44
45
46
47
48
49
50
51
52
53
54
55
56
57
58
59
60

5 DATA TRANSFER SERVICES

This section describes the Data Transfer Services defined for use in this Standard. The Data Transfer Services consist of the Network, Data Link, and Physical layer specifications. The Data Transfer Services defined in this section are designed for use by the Mobile Application Part.

This section specifies a minimal subset of *X.25* and guidelines on the use of the ANSI Signaling System No. 7 (*SS7*), and the ITU Signaling System No. 7 (*ITU-7*) for data transfer purposes. *X.25*, *SS7*, and *ITU-7* are technologically capable of supporting the requirements of this revision of *TIA/EIA-41*.

Within octets, bit A is transmitted first and bit H is transmitted last. Octets are transmitted in numeric order, with octet 1 transmitted first.

5.1 SS7-BASED DATA TRANSFER SERVICES

The SS7-based Data Transfer Services are comprised of the *ANSI SS7* Message Transfer Part (MTP) plus Signaling Connection Control Part (SCCP).

5.1.1 Message Transfer Part

The MTP is defined in *ANSI T1.111*, with the following supplemental information.

The MAP messages that are transported on an intersystem basis may be assigned a message priority value of either 0 or 1. The INVOKE, RETURN RESULT, RETURN ERROR, and REJECT components associated with the same operation (e.g. FacilitiesDirective) shall have the same message priority value. The recommended message priority values are shown below:

Table 1 MTP Message Priority Values for *TIA/EIA-41* Operations

<i>TIA/EIA-41</i> Operation	MTP Message Priority
AuthenticationDirective	0
AuthenticationDirectiveForward	0
AuthenticationFailureReport	0
AuthenticationRequest	0
AuthenticationStatusReport	0
BaseStationChallenge	0
Blocking	0
BulkDeregistration	0
CountRequest	0
FacilitiesDirective2	1
FacilitiesDirective	1
FacilitiesRelease	1
FeatureRequest	0

Table 1 (continued)

TIA/EIA-41 Operation	MTP Message Priority
FlashRequest	0
HandoffBack2	1
HandoffBack	1
HandoffMeasurementRequest2	0
HandoffMeasurementRequest	0
HandoffToThird	1
HandoffToThird2	1
InformationDirective	0
InformationForward	0
InterSystemAnswer	0
InterSystemPage	0
InterSystemPage2	0
InterSystemSetup	0
LocationRequest	0
MobileOnChannel	1
MSInactive	0
OriginationRequest	0
QualificationDirective	0
QualificationRequest	0
RandomVariableRequest	0
RedirectionDirective	1
RedirectionRequest	1
RegistrationCancellation	0
RegistrationNotification	0
RemoteUserInteractionDirective	0
ResetCircuit	0
RoutingRequest	0
SMSDeliveryBackward	0
SMSDeliveryForward	0
SMSDeliveryPointToPoint	0
SMSNotification	0
SMSRequest	0
TransferToNumberRequest	1
TrunkTest	0
TrunkTestDisconnect	0

Table 1 (concluded)

<i>TIA/EIA-41</i> Operation	MTP Message Priority
Unblocking	0
UnreliableRoamerDataDirective	0
UnsolicitedResponse	0

The message priority value may be determined by the *TIA/EIA-41* MAP based on the message type and may be passed down to the MTP through the SCCP. In the case when a REJECT message is to be returned, the message priority of the REJECT message should be the same as that of the rejected message.

5.1.2 Signaling Connection Control Part

For *TIA/EIA-41* applications, the SCCP is defined in *ANSI T1.112*, with the following exceptions and limitations:

- SCCP Class 0 connectionless service is used.
- The message types are Unitdata (UDT) and Unitdata Service (UDTS). The SCCP shall return a UDTS message when a received UDT message cannot be delivered to the specified destination and has the *return message on error* option set.
- Whether to set the *return message on error* or *discard message on error* option in the Protocol Class parameter of the UDT message is at the discretion of the implementation.
- The *TIA/EIA-41* Mobile Application Part has assigned the following Subsystem Numbers (SSN). Use of the following SSN values are recommended:
 - 5: Mobile Application Part (MAP)
 - 6: Home Location Register (HLR)
 - 7: Visitor Location Register (VLR)
 - 8: Mobile Switching Center (MSC)
 - 9: Equipment Identification Register (EIR) (reserved)¹
 - 10: Authentication Center (AC)
 - 11: Short Message Service
- In accordance with *ANSI T1.112* an SSN shall be included in all messages even if message routing is based on Global Title Translation (GTT). The null SSN (i.e., value 0) should be used when the subsystem is not known (e.g., before a global title translation takes place) per *ANSI T1.112*.
- Global Title Translation on Mobile Identification Number can be used for communication with the HLR. Global Title Indicator type 2 (0010) is used. A translation type value of 3 is used for “MIN to HLR” translation. The global title

¹Detailed transactions relative to SSN value 9 are for further study.

1 address information field contains the 10-digit MIN¹. The encoding scheme is
2 BCD. Each address signal is coded as described in Section 3.4.2.3.1 of the *ANSI*
3 *TI.112* specification.
4

- 5 • Global Title Translation on Mobile Identification Number can be used for
6 communication with a Message Center. Global Title Indicator type 2 (0010) is
7 used. A translation type value of 12 is used for Short Message Service for “MIN
8 to MC” translation. The encoding scheme is BCD. Each address signal is coded
9 as described in Section 3.4.2.3.1 of the *ANSI TI.112* specification.
10
- 11 • Use of signaling point codes, global titles, and subsystem numbers must meet
12 *ANSI TI.112* requirements; such that, any allowable combination of these
13 addressing elements is supported. For example, as stated in *TI.112.3*, Section
14 3.4.1:
15
16 “The address consists of any one or any combination of the following elements:
17 1) signaling point code,
18 2) global title (MIN-to-HLR for *TIA/EIA-41*),
19 3) subsystem number,
20 where, the referenced address is either the called party address or the calling
21 party address fields in SCCP messages.”
22
- 23 • When an originating functional entity sends an SS7 message with a global title
24 in the SCCP called party address field, the SCCP calling party address field
25 should include the point code and subsystem number of the originating
26 functional entity. Note that a Signaling Transfer Point (STP) is considered to be
27 an intermediate functional entity, not an originating functional entity.
28
- 29 • Replies to messages shall use the received Calling Party Address as the Called
30 Party Address, in accordance with *ANSI TI.112*.
31
32
33
34
35
36
37
38
39
40
41
42
43
44
45
46
47
48
49
50
51
52
53
54
55

56
57 ¹Dialed digits must be converted to a 10-digit MIN for the Location Request Task and Call Data
58 Request Task when Global Title Translation communication with the HLR is used.
59
60

5.2 X.25-BASED DATA TRANSFER SERVICES

The X.25-based Data Transfer Services are based on the following ISO standards:

- ISO-8878:1987; *Information Processing Systems — Data Communications — Use of X.25 to Provide the OSI Connection-Mode Network Service* (with two corrigenda); Geneva, Switzerland; 1987
- ISO-8878:1987/DAD 1; *Information Processing Systems — Data Communications — Use of X.25 to Provide the OSI Connection-Mode Network Service — Addendum 1: Priority*; Geneva, Switzerland; 1987
- ISO-8878:1987/DAD 2; *Information Processing Systems — Data Communications — Use of X.25 to Provide the OSI Connection-Mode Network Service — Addendum 2: Use of an X.25 PVC to Provide the OSI CONS*; Geneva, Switzerland; 1990
- ISO-8878:1987/DAD 3; *Information Processing Systems — Data Communications — Use of X.25 to Provide the OSI Connection-Mode Network Service — Addendum 3: Conformance*; Geneva, Switzerland; 1987
- ISO-8878:1987/DAM 3; *Information Processing Systems — Data Communications — Use of X.25 to Provide the OSI Connection-Mode Network Service — Amendment 3: Conformance*; Geneva, Switzerland; 1989
- ISO-8878:1987/PDAM 4; *Information Processing Systems — Data Communications — Use of X.25 to Provide the OSI Connection-Mode Network Service — Proposed Draft Amendment 4: Protocol Implementation Conformance Statement*; Geneva, Switzerland; 1990
- ISO-8208:1987; *Information Processing Systems — Data Communications — X.25 Packet Level Protocol for Data Terminal Equipment*; Geneva, Switzerland; 1987
- ISO-8208:1987/DAD 1.2; *Information Processing Systems — Data Communications — X.25 Packet Level Protocol for Data Terminal Equipment— Addendum 1: Alternative Logical Channel Identifier Assignment*; Geneva, Switzerland; 1989
- ISO-8208:1987/DAM 1; *Information Processing Systems — Data Communications — X.25 Packet Level Protocol for Data Terminal Equipment— Addendum 1: Alternative Logical Channel Identifier Assignment*; Geneva, Switzerland; 1990
- ISO-8208:1987/PDAD 2; *Revised Recommendation X.32 — Interface Between Data Terminal Equipment (DTE) and Data Circuit-Terminating Equipment (DCE) for Terminals Operation in the Packet-Mode and Accessing a Packet Switched Public Data Network Through a Public Switched Telephone Network or a Circuit Switched Public Data Network*; Geneva, Switzerland; 1985
- ISO-8208:1987/DAD 3; *Information Processing Systems — Data Communications — X.25 Packet Level Protocol for Data Terminal Equipment— Addendum 3: Conformance Requirements*; Geneva, Switzerland; 1989
- ISO-7776:1986; *Information Processing Systems — Data Communications — High-Level Data Link Control Procedures — Description of the X.25 LAPB-compatible DTE Data Link Procedures*; Geneva, Switzerland; 1986
- ISO-7776:1986/PDAD 1; *Information Processing Systems — Data Communications — High-Level Data Link Control Procedures — Description of the X.25 LAPB-compatible DTE Data Link Procedures — Addendum 1: Conformance Requirements*; Geneva, Switzerland; 1986

The ISO references extend CCITT X.25 with the DTE-DTE connections used in a peer relationship between two MSCs.

5.3 ITU-7-BASED DATA TRANSFER SERVICES

The ITU-7-based Data Transfer Services are comprised of the International Telecommunications Union Signaling System 7 Message Transfer Part (MTP) plus Signaling Connection Control Part (SCCP).

5.3.1 Message Transfer Part

The MTP is defined in *ITU Q.701 - Q.710*, with the following supplemental information.

The MAP messages that are transported on an intersystem basis may be assigned a message priority value of either 0 or 1. The INVOKE, RETURN RESULT, RETURN ERROR, and REJECT components associated with the same operation (e.g., FacilitiesDirective) shall have the same message priority value. The recommended message priority values are the same as Table 1.

The message priority value may be determined by the *TIA/EIA-41* MAP based on the message type and may be passed down to the MTP through the SCCP. In the case when a REJECT message is to be returned, the message priority of the REJECT message should be the same as that of the rejected message.

5.3.2 Signaling Connection Control Part

For *TIA/EIA-41* applications, the SCCP is defined in *ITU Q.711 - Q.714*, with the following exceptions and limitations:

- SCCP Class 0 connectionless service is used.
- The message types are Unitdata (UDT) and Unitdata Service (UDTS). The SCCP shall return a UDTS message when a received UDT message cannot be delivered to the specified destination and has the *return message on error* option set.
- Whether to set the *return message on error* or *discard message on error* option in the Protocol Class parameter of the UDT message is at the discretion of the implementation.
- Use of the following SSN values are recommended:
 - 5: Mobile Application Part (MAP)
 - 6: Home Location Register (HLR)
 - 7: Visitor Location Register (VLR)
 - 8: Mobile Switching Center (MSC)
 - 9: Equipment Identification Register (EIR) (reserved)¹
 - 10: Authentication Center (AC)
 - 11: Short Message Service

¹Detailed transactions relative to SSN value 9 are for further study.

- In accordance with *ITU Q.713* an SSN is recommended to be included in all messages even if message routing is based on Global Title Translation (GTT). The null SSN (i.e., value 0) should be used when the subsystem is not known (e.g., before a global title translation takes place).
- Global Title Translation on Mobile Identification Number (MIN) or International Mobile Station Identifier (IMSI) can be used for communication with the HLR. Global Title Indicator type 4 (0100) is used. The following figure represents the Global title format for indicator 0100:

8	7	6	5	4	3	2	1	
Translation type								Octet 1
Numbering plan				Encoding scheme				Octet 2
Spare		Nature of address indicator						Octet 3
Address information								Octet 3 and further

The global title address information field contains the 10-digit MIN¹.

The encoding scheme is 1 for an uneven number of BCD Digits, and 2 for an even number of BCD Digits.

The Nature of Address is 3 for National Significant Number and 4 for International Number.

Each address signal is coded as described the *ITU Q.713* specification.

Translation Type assignment is left to mutual agreements.

Numbering Plan for Global Titles based on MIN is left to mutual agreements.

¹Dialed digits must be converted to a 10-digit MIN for the Location Request Task and Call Data Request Task when Global Title Translation communication with the HLR is used.

1
2
3
4
5
6
7
8
9
10
11
12
13
14
15
16
17
18
19
20
21
22
23
24
25
26
27
28
29
30
31
32
33
34
35
36
37
38
39
40
41
42
43
44
45
46
47
48
49
50
51
52
53
54
55
56
57
58
59
60

- Global Title Translation on Mobile Identification Number or International Mobile Station Identity can be used for communication with a Message Center.
- Use of signaling point codes, global titles, and subsystem numbers must meet *ITU Q.713* requirements; such that, any allowable combination of these addressing elements is supported. For example, as stated in *ITU Q.713*:
 - “The address consists of one or any combination of the following elements:
 - 1) signaling point code,
 - 2) subsystem number,
 - 3) global title (MIN-to-HLR for *TIA/EIA-41*).”
- When an originating functional entity sends an SS7 message with a global title in the SCCP called party address field, the SCCP calling party address field should include the point code and subsystem number of the originating network entity.
- Replies to messages shall use the received Calling Party Address as the Called Party Address.

6 APPLICATION SERVICES

This section includes:

- A review of the Application Services architecture.
- A description of the Application Layer structure.
- The requirements on *ANSI Transaction Capabilities Application Part (TCAP)* formats and procedures which apply to this Standard.
- The formats and encoding of the signaling information comprising the *TIA/EIA-41 Mobile Application Part (MAP)*, both the operations and parameters.

6.1 APPLICATION SERVICES ARCHITECTURE

The Application Services architecture introduced in Section 4 is reproduced in the following figure.

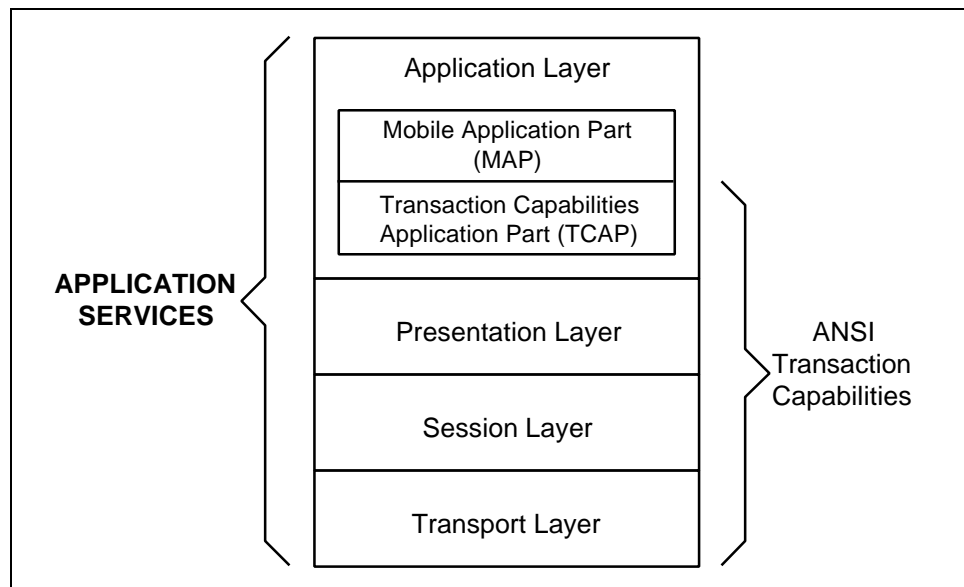

Figure 6 Application Services Architecture

Application Services are comprised of the *ANSI Transaction Capabilities (TC)* specified in *ANSI T1.114*, along with the *TIA/EIA-41 Mobile Application Part (MAP)*.

The TC Transport, Session, and Presentation layers are null layers in this Standard, just as they are described in *ANSI T1.114*. They are included here for completeness; future revisions of this Standard may make use of them.

The Application Layer contains the working part of the *TIA/EIA-41 Application Services*. It is described in the remainder of this Section.

6.2 APPLICATION LAYER STRUCTURE

The following figure illustrates the *TIA/EIA-41* Application Layer Structure.

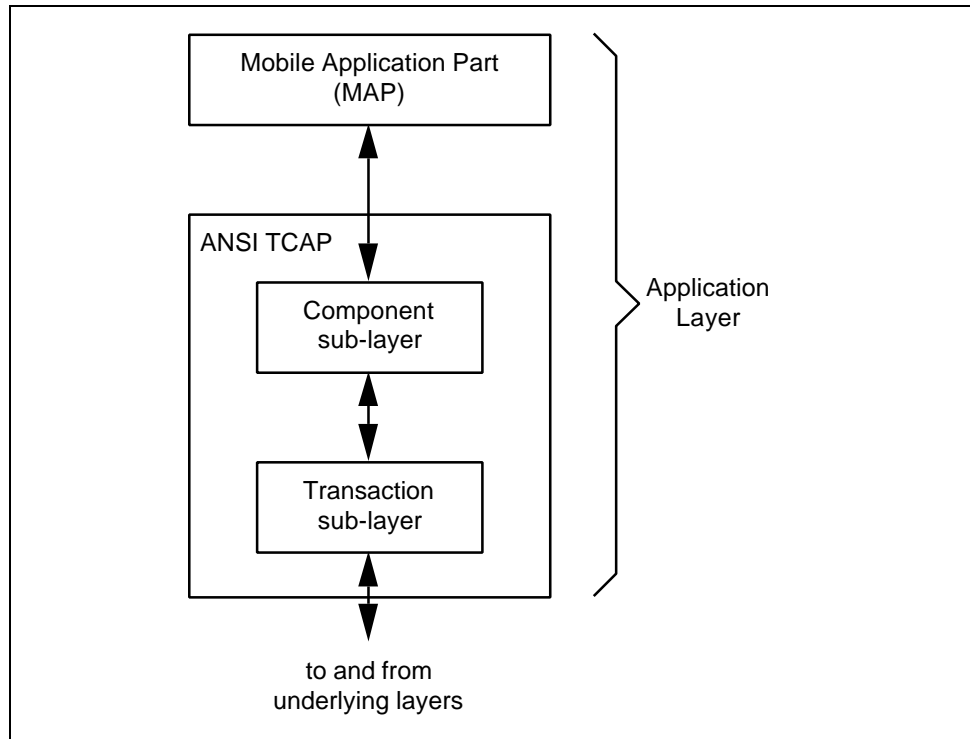

Figure 7 TIA/EIA-41 Application Layer Structure

As illustrated, the Mobile Application Part (MAP) defined in this Standard is supported by the *ANSI* Transaction Capabilities Application Part (TCAP). TCAP, in turn, is structured in two sub-layers:

- the component sub-layer, which deals with individual actions or data, called components.
- the transaction sub-layer, which deals with the exchange of messages containing components between two MAP entities.

The remainder of Section 6 contains specifications of the TCAP sub-layers (see 6.3), the MAP operations (see 6.4) and, finally, the MAP parameters (see 6.5).

6.3 TCAP FORMATS AND PROCEDURES

6.3.1 Transaction Portion

This Standard employs the TCAP package formats and procedures defined in *ANSI T1.114* with the following exceptions and limitations:

- Special procedures for “Handover,” defined in the *ANSI* TCAP standard, are not supported.

6.3.2 Component Portion

This Standard employs the TCAP component formats and procedures defined in *ANSI T1.114* with the following exceptions and limitations:

- Special procedures for “Handover,” defined in the *ANSI TCAP* standard, are not supported.
- The Operation Code Identifier is coded as Private TCAP.
- The Operation Code is partitioned into an Operation Family followed by a Specifier associated with each Operation Family member. For *TIA/EIA-41* the Operation Family is coded as decimal 9. Bit H of the Operation Family is always coded as 0.
- A TCAP INVOKE component shall contain a Component ID Length greater than zero.
- A TCAP RETURN RESULT component shall only be transmitted in response to an INVOKE Component.
- A TCAP RETURN ERROR component shall only be sent in response to an INVOKE component, not a RETURN RESULT component.
- If a problem is detected by TCAP (i.e., the received message does not conform to *ANSI T1.114.3*), a TCAP REJECT component with one of the following Problem Specifiers shall be sent:
 - a. All families, General, Transaction Portion: All specifiers.
 - b. INVOKE: Unrecognized Correlation ID.
 - c. RETURN RESULT: Unrecognized Correlation ID, Unexpected Return Result.
 - d. RETURN ERROR: Unrecognized Correlation ID, Unexpected Return Error.
- If a problem is detected by *TIA/EIA-41* MAP (i.e., the received message does not conform to *TIA/EIA-41*), a TCAP REJECT component with one of the following TCAP Problem Specifiers shall be sent:
 - a. INVOKE: Duplicate Invoke ID, Unrecognized Operation Code or Incorrect Parameter.
 - b. RETURN RESULT: Incorrect Parameter.
 - c. RETURN ERROR: Incorrect Parameter, Unrecognized Error, Unexpected Error.
- If an error is detected by an *TIA/EIA-41* MAP user except SMSDeliveryBackward, SMSDeliveryForward, and SMSDeliveryPointToPoint, a TCAP RETURN ERROR component shall be sent. For SMSDeliveryBackward, SMSDeliveryForward, and SMSDeliveryPointToPoint, a TCAP RETURN RESULT with an SMS_CauseCode parameter shall be sent.

Sections 6.3.2.1 through 6.3.2.4 summarize the formats of the *ANSI TCAP* components employed in this Standard.

6.3.2.1 TCAP INVOKE Component

The structure of an *ANSI* TCAP package containing an INVOKE component is shown in the following table.

Table 2 Structure of TCAP Package with INVOKE Component

Package Type Identifier
Total TCAP Message Length
Transaction ID Identifier
Transaction ID Length
Transaction IDs
Component Sequence Identifier
Component Sequence Length
Component Type Identifier
Component Length
Component ID Identifier
Component ID Length
Component IDs
Operation Code Identifier
Operation Code Length
Operation Code
Parameter Set Identifier
Parameter Set Length
Parameter Set

6.3.2.1.1. INVOKE Response Philosophy

1. If a functional entity receives an INVOKE with an incorrect TCAP message (e.g., ill-formatted), it shall respond with a REJECT to report this error.
2. If a functional entity receives an INVOKE and is unable to initiate or complete the operation, it shall respond with a RETURN ERROR.
3. If a functional entity receives an INVOKE and is able to complete the operation, it shall respond with a RETURN RESULT to report the completion of the operation, except for the messages HandoffMeasurementRequest and MobileOnChannel.

6.3.2.2 TCAP RETURN RESULT Component

The structure of a TCAP package containing a RETURN RESULT component is shown in the following table.

Table 3 Structure of TCAP Package with RETURN RESULT Component

Package Type Identifier
Total TCAP Message Length
Transaction ID Identifier
Transaction ID Length

Transaction IDs
Component Sequence Identifier
Component Sequence Length
Component Type Identifier
Component Length
Component ID Identifier
Component ID Length
Component IDs
Parameter Set Identifier
Parameter Set Length
Parameter Set

6.3.2.3 TCAP RETURN ERROR Component

The structure of a TCAP package containing a RETURN ERROR component is shown in the following table.

Table 4 Structure of TCAP Package with RETURN ERROR Component

Package Type Identifier
Total TCAP Message Length
Transaction ID Identifier
Transaction ID Length
Transaction IDs
Component Sequence Identifier
Component Sequence Length
Component Type Identifier
Component Length
Component ID Identifier
Component ID Length
Component IDs
Error Code Identifier
Error Code Length
Error Code
Parameter Set Identifier
Parameter Set Length
Parameter Set

The Parameter Set is encoded as follows:

Table 5 RETURN ERROR Parameters

RETURN ERROR Parameters				
Field	Value	Type	Reference	Notes
Identifier	SET [NATIONAL 18]	M	6.4.1.2	
Length	variable octets	M	6.4.1.1	
Contents				
FaultyParameter		O	6.5.2.66	a

Notes:

- a. Include if the error involved a specific parameter.

1
2
3
4
5
6
7
8
9
10
11
12
13
14
15
16
17
18
19
20
21
22
23
24
25
26
27
28
29
30
31
32
33
34
35
36
37
38
39
40
41
42
43
44
45
46
47
48
49
50
51
52
53
54
55
56
57
58
59
60

6.3.2.3.1. Error Definitions

The detailed handling of operation errors is specified in *TIA/EIA-41* Chapter 6.

The following definitions for errors are not exhaustive, but are included so that different manufacturers and users have a common understanding of the mapping between a reported error and the occurrence which generates it. The detection of the errors is not mandatory; however, if an error is detected for one of the examples given, then the indicated error code should be used. Implementations should not give cause for these reasons to be generated. For *SMSDeliveryBackward*, *SMSDeliveryForward*, and *SMSDeliveryPointToPoint*, detected errors should be mapped into the *SMS_CauseCode* parameter returned in the *RETURN RESULT*.

UnrecognizedMIN

- a. Supplied MIN is not currently served by the VLR.
- b. Supplied MIN is not currently served by the HLR.
- c. Supplied MIN is not currently served by the Serving MSC.
- d. Supplied MIN does not currently have an active call on an originating MSC.

UnrecognizedESN

- a. Supplied ESN does not match HLR's stored value for subscriber's ESN.
- b. Supplied ESN does not match VLR's stored value for subscriber's ESN.
- c. Supplied ESN is negative listed.

MIN/HLRMismatch

- a. Supplied MIN is not resident on the HLR.

OperationSequenceProblem

- a. Unexpected INVOKE in response to an INVOKE.
- b. Operation is not allowed in the current state.

ResourceShortage

- a. Functional entity congestion.
- b. Application (or function) congestion.
- c. Network congestion.
- d. No transaction IDs available.
- e. Internal processing resource shortage (memory, I/O, disk, processor, etc.)
- f. No TLDNs available.

OperationNotSupported

- a. Operation is not supported on the addressed functional entity.

TrunkUnavailable

- a. Specific requested trunk is not available.
- b. No trunks are available, but are required to perform the operation.

1
2
3
4
5
6
7
8
9
10
11
12
13
14
15
16
17
18
19
20
21
22
23
24
25
26
27
28
29
30
31
32
33
34
35
36
37
38
39
40
41
42
43
44
45
46
47
48
49
50
51
52
53
54
55
56
57
58
59
60

ParameterError

Parameter errors and parameter encoding errors (see 6.5.2). Parameter errors include exactly one *FaultyParameter* parameter in the parameter set (see 6.5.2.66).

UnrecognizedParameterValue

UnrecognizedParameterValue is a parameter value which is encoded properly (see 6.5.2), but its value is not recognized. *UnrecognizedParameterValue* errors should include exactly one *FaultyParameter* parameter in the parameter set (see 6.5.2.66).

SystemFailure

- a. System component failure.
- b. Network component failure.
- c. Chained operation failure.
- d. Required subsystem failure.

FeatureInactive

- a. Cannot reroute call because indicated feature is inactive.

MissingParameter

- a. Expected optional parameter is missing.
- b. All profile parameters are expected, but some are missing.
- c. All qualification parameters are expected, but some are missing.

MissingParameter errors should include exactly one *FaultyParameter* parameter in the parameter set (see 6.5.2.66).

Note that this Error Code is not used to indicate a missing mandatory parameter, a REJECT message with a Problem Specifier of *Incorrect Parameter* is used in this case.

For *TIA/EIA-41* the Error Code Identifier is coded as Private TCAP. Error Codes are coded as follows:

Table 6 Error Codes

Error Code Name	Error Code							
	H	G	F	E	D	C	B	A
UnrecognizedMIN	1	0	0	0	0	0	0	1
UnrecognizedESN	1	0	0	0	0	0	1	0
MIN/HLRMismatch	1	0	0	0	0	0	1	1
OperationSequenceProblem	1	0	0	0	0	1	0	0
ResourceShortage	1	0	0	0	0	1	0	1
OperationNotSupported	1	0	0	0	0	1	1	0
TrunkUnavailable	1	0	0	0	0	1	1	1
ParameterError	1	0	0	0	1	0	0	0
SystemFailure	1	0	0	0	1	0	0	1
UnrecognizedParameterValue	1	0	0	0	1	0	1	0
FeatureInactive	1	0	0	0	1	0	1	1
MissingParameter	1	0	0	0	1	1	0	0
Other Error Codes are Reserved	Reserved (Note a)							
Reserved for Protocol Extension (Note b)	1	1	1	0	0	0	0	0
	through							
	1	1	1	1	1	1	1	1

Notes:

- a. Treat a reserved value the same as value 133 (decimal), *ResourceShortage*.
- b. Error codes 224 to 255 (decimal) shall be reserved for protocol extension. If unknown, treat the same as value 133 (decimal), *Resource Shortage*.

6.3.2.4 TCAP REJECT Component

The structure of a TCAP package containing a REJECT component is shown in the following table.

Table 7 Structure of TCAP Package with REJECT Component

Package Type Identifier
Total TCAP Message Length
Transaction ID Identifier
Transaction ID Length
Transaction IDs
Component Sequence Identifier
Component Sequence Length
Component Type Identifier
Component Length
Component ID Identifier
Component ID Length
Component IDs
Problem Code Identifier
Problem Code Length
Problem Code
Parameter Set Identifier
Parameter Set Length
Parameter Set

A TCAP REJECT message with a TCAP Problem Code containing a Problem Specifier with one of the following values may include one occurrence of a FaultyParameter parameter identifying the parameter in error:

- a. INVOKE: *Incorrect Parameter.*
- b. RETURN RESULT: *Incorrect Parameter.*
- c. RETURN ERROR: *Incorrect Parameter.*

When a functional entity receives a message with protocol errors, it shall return with a REJECT message.

When a functional entity receives a REJECT message it should:

- a) Stop timer for current task.
- b) Exit the current task.
- c) Begin recovery procedures according to the functional entity's internal algorithm.
- d) If it needs to respond to another functional entity due to an undergoing transaction, it should send a RETURN ERROR message indicating *System Failure.*

6.4 MAP OPERATIONS

6.4.1 General

6.4.1.1 Operation Formats

This Standard employs the TCAP operation formats defined in *ANSI T1.114* with the exceptions and limitations specified in Section 6.3.2.

6.4.1.2 Operation Specifiers

The following table lists the *TIA/EIA-41* MAP Operation Specifiers.

Table 8 TIA/EIA-41 MAP Operation Specifiers

Operation Name	Operation Specifier								Decimal
	H	G	F	E	D	C	B	A	
not used	0	0	0	0	0	0	0	0	0
HandoffMeasurementRequest	0	0	0	0	0	0	0	1	1
FacilitiesDirective	0	0	0	0	0	0	1	0	2
MobileOnChannel	0	0	0	0	0	0	1	1	3
HandoffBack	0	0	0	0	0	1	0	0	4
FacilitiesRelease	0	0	0	0	0	1	0	1	5
QualificationRequest	0	0	0	0	0	1	1	0	6
QualificationDirective	0	0	0	0	0	1	1	1	7
Blocking	0	0	0	0	1	0	0	0	8
Unblocking	0	0	0	0	1	0	0	1	9
ResetCircuit	0	0	0	0	1	0	1	0	10
TrunkTest	0	0	0	0	1	0	1	1	11
TrunkTestDisconnect	0	0	0	0	1	1	0	0	12
RegistrationNotification	0	0	0	0	1	1	0	1	13
RegistrationCancellation	0	0	0	0	1	1	1	0	14
LocationRequest	0	0	0	0	1	1	1	1	15
RoutingRequest	0	0	0	1	0	0	0	0	16
FeatureRequest	0	0	0	1	0	0	0	1	17
Reserved	0	0	0	1	0	0	1	0	18
Reserved	0	0	0	1	0	0	1	1	19
UnreliableRoamerDataDirective	0	0	0	1	0	1	0	0	20
Reserved	0	0	0	1	0	1	0	1	21
MSInactive	0	0	0	1	0	1	1	0	22
TransferToNumberRequest	0	0	0	1	0	1	1	1	23

Table 8 (concluded)

Operation Name	Operation Specifier								Decimal
	H	G	F	E	D	C	B	A	
RedirectionRequest	0	0	0	1	1	0	0	0	24
HandoffToThird	0	0	0	1	1	0	0	1	25
FlashRequest	0	0	0	1	1	0	1	0	26
AuthenticationDirective	0	0	0	1	1	0	1	1	27
AuthenticationRequest	0	0	0	1	1	1	0	0	28
BaseStationChallenge	0	0	0	1	1	1	0	1	29
AuthenticationFailureReport	0	0	0	1	1	1	1	0	30
CountRequest	0	0	0	1	1	1	1	1	31
InterSystemPage	0	0	1	0	0	0	0	0	32
UnsolicitedResponse	0	0	1	0	0	0	0	1	33
BulkDeregistration	0	0	1	0	0	0	1	0	34
HandoffMeasurementRequest2	0	0	1	0	0	0	1	1	35
FacilitiesDirective2	0	0	1	0	0	1	0	0	36
HandoffBack2	0	0	1	0	0	1	0	1	37
HandoffToThird2	0	0	1	0	0	1	1	0	38
AuthenticationDirectiveForward	0	0	1	0	0	1	1	1	39
AuthenticationStatusReport	0	0	1	0	1	0	0	0	40
Reserved	0	0	1	0	1	0	0	1	41
InformationDirective	0	0	1	0	1	0	1	0	42
InformationForward	0	0	1	0	1	0	1	1	43
InterSystemAnswer	0	0	1	0	1	1	0	0	44
InterSystemPage2	0	0	1	0	1	1	0	1	45
InterSystemSetup	0	0	1	0	1	1	1	0	46
OriginationRequest	0	0	1	0	1	1	1	1	47
RandomVariableRequest	0	0	1	1	0	0	0	0	48
RedirectionDirective	0	0	1	1	0	0	0	1	49
RemoteUserInteractionDirective	0	0	1	1	0	0	1	0	50
SMSDeliveryBackward	0	0	1	1	0	0	1	1	51
SMSDeliveryForward	0	0	1	1	0	1	0	0	52
SMSDeliveryPointToPoint	0	0	1	1	0	1	0	1	53
SMSNotification	0	0	1	1	0	1	1	0	54
SMSRequest	0	0	1	1	0	1	1	1	55
Other Values Reserved	X	X	X	X	X	X	X	X	...
Reserved for Protocol Extension	1	1	1	0	0	0	0	0	224
	through								...
	1	1	1	1	1	1	1	1	255

6.4.1.3 Mapping of Operations onto TCAP Package Types

The following table lists the mapping of *TIA/EIA-41* Operations onto *ANSI* TCAP package types.

Table 9 Mapping of *TIA/EIA-41* Operations onto TCAP Package Types

Operation Name	Component Type	Package Type
FacilitiesDirective	INVOKE (LAST) RETURN RESULT (LAST) RETURN ERROR REJECT	QUERY WITH PERMISSION CONVERSATION WITH PERMISSION RESPONSE RESPONSE
FacilitiesDirective2	INVOKE (LAST) RETURN RESULT (LAST) RETURN ERROR REJECT	QUERY WITH PERMISSION CONVERSATION WITH PERMISSION RESPONSE RESPONSE
MobileOnChannel	INVOKE (LAST)	RESPONSE
RemoteUser- InteractionDirective	INVOKE (LAST) RETURN RESULT (LAST) RETURN ERROR REJECT	CONVERSATION WITHOUT PERMISSION CONVERSATION WITH PERMISSION CONVERSATION WITH PERMISSION CONVERSATION WITH PERMISSION
All other operations	INVOKE (LAST) RETURN RESULT (LAST) RETURN ERROR REJECT	QUERY WITH PERMISSION RESPONSE RESPONSE RESPONSE

6.4.2 Operation Definitions

The following table summarizes the operations defined for the *TIA/EIA-41* MAP:

Table 10 Summary of MAP Operations

Operation	Reference
AuthenticationDirective	6.4.2.1
AuthenticationDirectiveForward	6.4.2.2
AuthenticationFailureReport	6.4.2.3
AuthenticationRequest	6.4.2.4
AuthenticationStatusReport	6.4.2.5
BaseStationChallenge	6.4.2.6
Blocking	6.4.2.7
BulkDeregistration	6.4.2.8
CountRequest	6.4.2.9
FacilitiesDirective	6.4.2.10
FacilitiesDirective2	6.4.2.11
FacilitiesRelease	6.4.2.12
FeatureRequest	6.4.2.13
FlashRequest	6.4.2.14
HandoffBack	6.4.2.15
HandoffBack2	6.4.2.16
HandoffMeasurementRequest	6.4.2.17
HandoffMeasurementRequest2	6.4.2.18
HandoffToThird	6.4.2.19
HandoffToThird2	6.4.2.20
InformationDirective	6.4.2.21
InformationForward	6.4.2.22
InterSystemAnswer	6.4.2.23
InterSystemPage	6.4.2.24
InterSystemPage2	6.4.2.25
InterSystemSetup	6.4.2.26
LocationRequest	6.4.2.27
MobileOnChannel	6.4.2.28
MSInactive	6.4.2.29
OriginationRequest	6.4.2.30

Table 10 (concluded)

Operation	Reference
QualificationDirective	6.4.2.31
QualificationRequest	6.4.2.32
RandomVariableRequest	6.4.2.33
RedirectionDirective	6.4.2.34
RedirectionRequest	6.4.2.35
RegistrationCancellation	6.4.2.36
RegistrationNotification	6.4.2.37
RemoteUserInteractionDirective	6.4.2.38
ResetCircuit	6.4.2.39
RoutingRequest	6.4.2.40
SMSDeliveryBackward	6.4.2.41
SMSDeliveryForward	6.4.2.42
SMSDeliveryPointToPoint	6.4.2.43
SMSNotification	6.4.2.44
SMSRequest	6.4.2.45
TransferToNumberRequest	6.4.2.46
TrunkTest	6.4.2.47
TrunkTestDisconnect	6.4.2.48
Unblocking	6.4.2.49
UnreliableRoamerDataDirective	6.4.2.50
UnsolicitedResponse	6.4.2.51

6.4.2.1 AuthenticationDirective

The AuthenticationDirective operation is used to request modification of an MS's authentication parameters.

The AuthenticationDirective operation is initiated with a TCAP INVOKE (LAST). This is carried by a TCAP QUERY WITH PERMISSION package. The Parameter Set is encoded as follows:

Table 11 AuthenticationDirective INVOKE Parameters

AuthenticationDirective INVOKE Parameters				Timer: ADT
Field	Value	Type	Reference	Notes
Identifier	SET [NATIONAL 18]	M	6.3.2.1	
Length	variable octets	M	6.3.2.1	
Contents				
	ElectronicSerialNumber	M	6.5.2.63	
	MobileIdentificationNumber	M	6.5.2.81	
	AuthenticationAlgorithmVersion	O	6.5.2.7	a
	AuthenticationResponseUniqueChallenge	O	6.5.2.12	b
	CallHistoryCount	O	6.5.2.18	c
	DenyAccess	O	6.5.2.54	d
	LocationAreaID	O	6.5.2.77	e
	RandomVariableSSD	O	6.5.2.103	f
	RandomVariableUniqueChallenge	O	6.5.2.104	b
	SenderIdentificationNumber	O	6.5.2.116	g
	SharedSecretData	O	6.5.2.119	c
	SSDNotShared	O	6.5.2.141	h
	UpdateCount	O	6.5.2.163	i

Notes:

- a. May be included if SharedSecretData parameter is included.
- b. Include if the MSC-V shall initiate a Unique Challenge to the MS.
- c. Include if the SystemCapabilities include *CAVE Execution* and AC administration policies allow distribution of the SSD.
- d. Include if release of system resources allocated for this access may be initiated by the MSC. This may include disconnection of any call in progress.
- e. May be included from VLR to MSC-V. Usage from the HLR or AC is not defined.
- f. Include if the MSC-V shall initiate an SSD update to the MS.
- g. Include to identify the functional entity sending this message.
- h. Include if the SSD at the VLR shall be discarded.
- i. Include if the MSC-V shall initiate a COUNT Update to the MS.

The AuthenticationDirective operation success is reported with a TCAP RETURN RESULT (LAST). This is carried by a TCAP RESPONSE package. The Parameter Set is encoded as follows:

Table 12 AuthenticationDirective RETURN RESULT Parameters

AuthenticationDirective RETURN RESULT Parameters				
Field	Value	Type	Reference	Notes
Identifier	SET [NATIONAL 18]	M	6.3.2.2	
Length	variable octets	M	6.3.2.2	
Contents				
CallHistoryCount		O	6.5.2.18	a

Notes:

- a. Include if available at the VLR and required per bilateral agreement.

6.4.2.2 AuthenticationDirectiveForward

The AuthenticationDirectiveForward operation is sent from the Anchor MSC toward the Serving MSC to request the initiation of a Unique Challenge to the indicated MS. This message can be relayed through the Tandem MSC(s).

The AuthenticationDirectiveForward operation is initiated with a TCAP INVOKE (LAST). This is carried by a TCAP QUERY WITH PERMISSION package. The Parameter Set is encoded as follows:

Table 13 AuthenticationDirectiveForward INVOKE Parameters

AuthenticationDirectiveForward INVOKE Parameters				Timer: ADFT
Field	Value	Type	Reference	Notes
Identifier	SET [NATIONAL 18]	M	6.3.2.1	
Length	variable octets	M	6.3.2.1	
Contents				
	InterMSCCircuitID	M	6.5.2.72	
	MobileIdentificationNumber	M	6.5.2.81	
	AuthenticationResponseUniqueChallenge	O	6.5.2.12	a
	RandomVariableUniqueChallenge	O	6.5.2.104	a

Notes:

- a. Include if the Serving MSC shall initiate a Unique Challenge to the indicated MS. These parameters are required for *IS-41-C* but may not be needed for future use of the same operation.

The AuthenticationDirectiveForward operation success is reported with a TCAP RETURN RESULT (LAST). This is carried by a TCAP RESPONSE package. The Parameter Set is encoded as follows:

Table 14 AuthenticationDirectiveForward RETURN RESULT Parameters

AuthenticationDirectiveForward RETURN RESULT Parameters				
Field	Value	Type	Reference	Notes
Identifier	SET [NATIONAL 18]	M	6.3.2.2	
Length	variable octets	M	6.3.2.2	
Contents				
	UniqueChallengeReport	M	6.5.2.162	

6.4.2.3 AuthenticationFailureReport

The AuthenticationFailureReport operation is used to report on the failure of an autonomously initiated authentication operation for an MS.

The AuthenticationFailureReport operation is initiated with a TCAP INVOKE (LAST). This is carried by a TCAP QUERY WITH PERMISSION package. The Parameter Set is encoded as follows:

Table 15 AuthenticationFailureReport INVOKE Parameters

AuthenticationFailureReport INVOKE Parameters				Timer: AFRT
Field	Value	Type	Reference	Notes
Identifier	SET [NATIONAL 18]	M	6.3.2.1	
Length	variable octets	M	6.3.2.1	
Contents				
ElectronicSerialNumber		M	6.5.2.63	
MobileIdentificationNumber		M	6.5.2.81	
ReportType		M	6.5.2.112	
SystemAccessType		M	6.5.2.145	
SystemCapabilities (Serving)		M	6.5.2.146	
CallHistoryCount		O	6.5.2.18	a
CallHistoryCountExpected		O	6.5.2.19	a
MSCID (Serving MSC)		O	6.5.2.82	b
ReportType		O	6.5.2.112	c
SenderIdentificationNumber		O	6.5.2.116	d

Notes:

- a. Include if ReportType parameter value is .
- b. Should be included on *IS-41-C* or later.
- c. Not required for *IS-41-C*. For TSB51, two ReportType parameters are needed to report the outcome of an SSD Update and the Unique Challenge that is performed after the Base Station Challenge is completed. The first (mandatory) ReportType parameter indicates the outcome of the SSD Update. The second ReportType parameter (optional) reports on the outcome of the Unique Challenge when the SSD Update was successful.
- d. Include to identify message sender the functional entity sending the message.

The AuthenticationFailureReport operation success is reported with a TCAP RETURN RESULT (LAST). This is carried by a TCAP RESPONSE package. The Parameter Set is encoded as follows:

Table 16 AuthenticationFailureReport RETURN RESULT Parameters

AuthenticationFailureReport RETURN RESULT Parameters				
Field	Value	Type	Reference	Notes
Identifier	SET [NATIONAL 18]	M	6.3.2.2	
Length	variable octets	M	6.3.2.2	
Contents				
AuthenticationAlgorithmVersion		O	6.5.2.7	a
AuthenticationResponseUniqueChallenge		O	6.5.2.12	b
CallHistoryCount		O	6.5.2.18	c
DenyAccess		O	6.5.2.54	d
RandomVariableSSD		O	6.5.2.103	e
RandomVariableUniqueChallenge		O	6.5.2.104	b
SharedSecretData		O	6.5.2.119	c
SSDNotShared		O	6.5.2.141	f
TerminalType		O	6.5.2.154	g
UpdateCount		O	6.5.2.163	h

Notes:

- a. May be included if the SharedSecretData parameter is included.
- b. Include if the MSC-V shall initiate a Unique Challenge to the MS.
- c. Include if the SystemCapabilities include *CAVE execution* and AC administration policies allow distribution of the SSD.
- d. Include if the MSC may initiate a release of system resources allocated for this access. This may include disconnection of any call in progress.
- e. Include if the MSC-V shall initiate an SSD update to the MS.
- f. Include if the VLR shall discard the SSD.
- g. Should be included for *IS-41-C* or later.
- h. Include if the MSC-V shall initiate a COUNT Update to the MS.

6.4.2.4 AuthenticationRequest

The AuthenticationRequest operation is used to request authentication of an authentication-capable MS.

The AuthenticationRequest operation is initiated with a TCAP INVOKE (LAST). This is carried by a TCAP QUERY WITH PERMISSION package. The Parameter Set is encoded as follows:

Table 17 AuthenticationRequest INVOKE Parameters

AuthenticationRequest INVOKE Parameters				Timer: ART
Field	Value	Type	Reference	Notes
Identifier	SET [NATIONAL 18]	M	6.3.2.1	
Length	variable octets	M	6.3.2.1	
Contents				
ElectronicSerialNumber		M	6.5.2.63	
MobileIdentificationNumber		M	6.5.2.81	
MSCID (Serving MSC)		M	6.5.2.82	
SystemAccessType		M	6.5.2.145	
SystemCapabilities (Serving)		M	6.5.2.146	
AuthenticationData		O	6.5.2.9	a
AuthenticationResponse		O	6.5.2.10	b
CallHistoryCount		O	6.5.2.18	b
ConfidentialityModes (Actual)		O	6.5.2.50	c
Digits (Dialed)		O	6.5.2.58	d
PC_SSN (Serving MSC or VLR or HLR)		O	6.5.2.93	e
RandomVariable		O	6.5.2.101	b
SenderIdentificationNumber		O	6.5.2.116	f
TerminalType		O	6.5.2.154	g

Notes:

- a. Include if the SystemAccessType value is and if the air interface encoding of dialed digits is not TBCD.
- b. Include if the SystemAccessType value is , , or and the authentication parameters were requested (AUTH=1 in the Overhead Message Train) on the system access.
- c. Include if the SystemAccessType value is and if the SignalingMessageEncryptionKey parameter was provided to the Serving MSC.
- d. Include if the SystemAccessType value is or .
- e. Include to override lower layer addressing
- f. Include to identify the functional entity sending the message.
- g. Should be included on *IS-41-C* or later.

The AuthenticationRequest operation success is reported with a TCAP RETURN RESULT (LAST). This is carried by a TCAP RESPONSE package. The Parameter Set is encoded as follows:

Table 18 AuthenticationRequest RETURN RESULT Parameters

AuthenticationRequest RETURN RESULT Parameters				
Field	Value	Type	Reference	Notes
Identifier	SET [NATIONAL 18]	M	6.3.2.2	
Length	variable octets	M	6.3.2.2	
Contents				
AuthenticationAlgorithmVersion		O	6.5.2.7	a
AuthenticationResponseUniqueChallenge		O	6.5.2.12	b
CallHistoryCount		O	6.5.2.18	c
CDMAPrivateLongCodeMask		O	6.5.2.36	d
DenyAccess		O	6.5.2.54	e
RandomVariableSSD		O	6.5.2.103	f
RandomVariableUniqueChallenge		O	6.5.2.104	b
SharedSecretData		O	6.5.2.119	c
SignalingMessageEncryptionKey		O	6.5.2.120	g
SSDNotShared		O	6.5.2.141	h
UpdateCount		O	6.5.2.163	i
VoicePrivacyMask		O	6.5.2.166	d

Notes:

- a. May be included if the SharedSecretData parameter is included.
- b. Include if the MSC-V shall initiate a Unique Challenge to the MS.
- c. Include if the SystemCapabilities include and AC administration policies allow distribution of the SSD.
- d. Include if appropriate and the SystemAccessType value is or .
- e. Include if the MSC may initiate a release of system resources allocated for this access. This may include disconnection of any call in progress. If included, no other optional parameters shall be included.
- f. Include if the MSC-V shall initiate an SSD update and a Unique Challenge to the MS.
- g. Include if the SystemAccessType value is or .
- h. Include if the VLR shall discard the SSD.
- i. Include if the MSC-V should initiate COUNT Update to the MS.

6.4.2.5 AuthenticationStatusReport

The AuthenticationStatusReport operation is used to report on the outcome of an authentication operation initiated by the AC or VLR if SSD is shared.

The AuthenticationStatusReport operation is initiated with a TCAP INVOKE (LAST). This is carried by a TCAP QUERY WITH PERMISSION package. The Parameter Set is encoded as follows:

Table 19 AuthenticationStatusReport INVOKE Parameters

AuthenticationStatusReport INVOKE Parameters				Timer: ASRT
Field	Value	Type	Reference	Notes
Identifier	SET [NATIONAL 18]	M	6.3.2.1	
Length	variable octets	M	6.3.2.1	
Contents				
	ElectronicSerialNumber	M	6.5.2.63	
	MobileIdentificationNumber	M	6.5.2.81	
	SystemCapabilities (Serving)	M	6.5.2.146	
	CountUpdateReport	O	6.5.2.52	a
	SenderIdentificationNumber	O	6.5.2.116	b
	SSDUpdateReport	O	6.5.2.142	c
	UniqueChallengeReport	O	6.5.2.162	d

Notes:

- a. Include if report related to COUNT Update.
- b. Include to identify the functional entity sending the message.
- c. Include if report related to SSD Update.
- d. Include if report related to Unique Challenge.

The AuthenticationStatusReport operation success is reported with a TCAP RETURN RESULT (LAST). This is carried by a TCAP RESPONSE package. The Parameter Set is encoded as follows:

Table 20 AuthenticationStatusReport RETURN RESULT Parameters

AuthenticationStatusReport RETURN RESULT Parameters				
Field	Value	Type	Reference	Notes
Identifier	SET [NATIONAL 18]	M	6.3.2.2	
Length	variable octets	M	6.3.2.2	
Contents				
AuthenticationAlgorithmVersion		O	6.5.2.7	a
AuthenticationResponseUniqueChallenge		O	6.5.2.12	b
CallHistoryCount		O	6.5.2.18	c
DenyAccess		O	6.5.2.54	d
RandomVariableSSD		O	6.5.2.103	e
RandomVariableUniqueChallenge		O	6.5.2.104	b
SharedSecretData		O	6.5.2.119	c
SSDNotShared		O	6.5.2.141	f
UpdateCount		O	6.5.2.163	g

Notes:

- a. May be included if the SharedSecretData parameter is included.
- b. Include if the MSC-V shall initiate a Unique Challenge to the MS.
- c. Include if the SystemCapabilities include *CAVE Execution* and AC administration policies allow distribution of the SSD.
- d. Include if the MSC may initiate a release of system resources allocated for this access. This may include disconnection of any call in progress.
- e. Include if the MSC-V shall initiate an SSD update to the MS.
- f. Include if the VLR shall discard the SSD.
- g. Include if the MSC-V shall initiate a COUNT Update to the MS.

6.4.2.6 BaseStationChallenge

The BaseStationChallenge operation is used to request a response to a Base Station Challenge Order received from an MS.

The BaseStationChallenge operation is initiated with a TCAP INVOKE (LAST). This is carried by a TCAP QUERY WITH PERMISSION package. The Parameter Set is encoded as follows:

Table 21 BaseStationChallenge INVOKE Parameters

BaseStationChallenge INVOKE Parameters				Timer: BSCT
Field	Value	Type	Reference	Notes
Identifier	SET [NATIONAL 18]	M	6.3.2.1	
Length	variable octets	M	6.3.2.1	
Contents				
ElectronicSerialNumber		M	6.5.2.63	
MobileIdentificationNumber		M	6.5.2.81	
RandomVariableBaseStation		M	6.5.2.102	
SenderIdentificationNumber		O	6.5.2.116	a

Notes:

- a. Include to identify the functional entity sending the message.

The BaseStationChallenge operation success is reported with a TCAP RETURN RESULT (LAST). This is carried by a TCAP RESPONSE package. The Parameter Set is encoded as follows:

Table 22 BaseStationChallenge RETURN RESULT Parameters

BaseStationChallenge RETURN RESULT Parameters				
Field	Value	Type	Reference	Notes
Identifier	SET [NATIONAL 18]	M	6.3.2.2	
Length	variable octets	M	6.3.2.2	
Contents				
AuthenticationResponseBaseStation		M	6.5.2.11	

6.4.2.7 Blocking

The Blocking operation is used to inform an MSC that the designated circuit has been removed from service.

The Blocking operation is initiated with a TCAP INVOKE (LAST). This is carried by a TCAP QUERY WITH PERMISSION package. The Parameter Set is encoded as follows:

Table 23 Blocking INVOKE Parameters

Blocking INVOKE Parameters				Timer: BLKT
Field	Value	Type	Reference	Notes
Identifier	SET [NATIONAL 18]	M	6.3.2.1	
Length	variable octets	M	6.3.2.1	
Contents				
	InterMSCCircuitID	M	6.5.2.72	

The Blocking operation success is reported with a TCAP RETURN RESULT (LAST). This is carried by a TCAP RESPONSE package. The Parameter Set is encoded as follows:

Table 24 Blocking RETURN RESULT Parameters

Blocking RETURN RESULT Parameters				
Field	Value	Type	Reference	Notes
Identifier	SET [NATIONAL 18]	M	6.3.2.2	
Length	zero octets	M	6.3.2.2	
Contents				

6.4.2.8 BulkDeregistration

This BulkDeregistration operation is used by a VLR to inform the HLR that all MS data associated with the HLR has been removed from the VLR.

The BulkDeregistration operation is initiated with a TCAP INVOKE (LAST). This is carried by a TCAP QUERY WITH PERMISSION package. The Parameter Set is encoded as follows:

Table 25 BulkDeregistration INVOKE Parameters

BulkDeregistration INVOKE Parameters				Timer: BDT
Field	Value	Type	Reference	Notes
Identifier	SET [NATIONAL 18]	M	6.3.2.1	
Length	variable octets	M	6.3.2.1	
Contents				
SenderIdentificationNumber		M	6.5.2.116	

The BulkDeregistration operation success is reported with a TCAP RETURN RESULT (LAST). This is carried by a TCAP RESPONSE package. The Parameter Set is encoded as follows:

Table 26 BulkDeregistration RETURN RESULT Parameters

BulkDeregistration RETURN RESULT Parameters				
Field	Value	Type	Reference	Notes
Identifier	SET [NATIONAL 18]	M	6.3.2.2	
Length	zero octets	M	6.3.2.2	
Contents				

6.4.2.9 CountRequest

The CountRequest operation is used to obtain the current value of the CallHistoryCount parameter.

The CountRequest operation is initiated with a TCAP INVOKE (LAST). This is carried by a TCAP QUERY WITH PERMISSION package. The Parameter Set is encoded as follows:

Table 27 CountRequest INVOKE Parameters

CountRequest INVOKE Parameters				Timer: CRT
Field	Value	Type	Reference	Notes
Identifier	SET [NATIONAL 18]	M	6.3.2.1	
Length	variable octets	M	6.3.2.1	
Contents				
	ElectronicSerialNumber	M	6.5.2.63	
	MobileIdentificationNumber	M	6.5.2.81	
	SenderIdentificationNumber	O	6.5.2.116	a

Notes:

- a. Include to identify the functional entity sending the message.

The CountRequest operation success is reported with a TCAP RETURN RESULT (LAST). This is carried by a TCAP RESPONSE package. The Parameter Set is encoded as follows:

Table 28 CountRequest RETURN RESULT Parameters

CountRequest RETURN RESULT Parameters				
Field	Value	Type	Reference	Notes
Identifier	SET [NATIONAL 18]	M	6.3.2.2	
Length	variable octets	M	6.3.2.2	
Contents				
	CallHistoryCount	O	6.5.2.18	a

Notes:

- a. Include if CallHistoryCount was maintained by the VLR.

6.4.2.10 FacilitiesDirective

See FacilitiesDirective2 for enhanced use.

The FacilitiesDirective operation is used to request that the Target MSC initiate the Handoff-Forward task.

The FacilitiesDirective operation is initiated with a TCAP INVOKE (LAST). This is carried by a TCAP QUERY WITH PERMISSION package. The Parameter Set is encoded as follows:

Table 29 FacilitiesDirective INVOKE Parameters

FacilitiesDirective INVOKE Parameters				Timer: HOT
Field	Value	Type	Reference	Notes
Identifier	SET [NATIONAL 18]	M	6.3.2.1	
Length	variable octets	M	6.3.2.1	
Contents				
BillingID		M	6.5.2.16	
ChannelData (Serving)		M	6.5.2.47	a
ElectronicSerialNumber		M	6.5.2.63	
InterMSCCircuitID		M	6.5.2.72	
InterSwitchCount		M	6.5.2.73	
MobileIdentificationNumber		M	6.5.2.81	
ServingCellID		M	6.5.2.117	
StationClassMark		M	6.5.2.143	
TargetCellID		M	6.5.2.148	
ConfidentialityModes (Desired)		O	6.5.2.50	b
HandoffReason		O	6.5.2.70	c
HandoffState		O	6.5.2.71	d
SignalingMessageEncryptionKey		O	6.5.2.120	e
TDMA BurstIndicator (Serving)		O	6.5.2.151	f
TDMA CallMode		O	6.5.2.152	g
TDMA ChannelData (Serving)		O	6.5.2.153	f
VoicePrivacyMask		O	6.5.2.166	h

Notes:

- a. This parameter has a length of 0 if a TDMA channel is in use.
- b. Include if MS supports Signaling Message Encryption or Voice Privacy. The parameter shall be carried forward in any subsequent handoff.
- c. Include if known.
- d. Include if call is still in the awaiting answer or alerting state.
- e. Include if Signaling Message Encryption may apply. The parameter shall be carried forward in any subsequent handoff.
- f. Include if a TDMA channel is in use.

- 1
2
3
4
5
6
7
8
9
10
- g. Include to indicate the acceptable call modes.
 - h. Include if the Voice Privacy may apply. The parameter shall be carried forward in any subsequent handoff.

The FacilitiesDirective operation success is reported with a TCAP RETURN RESULT (LAST). This is carried by a TCAP CONVERSATION WITH PERMISSION package. The Parameter Set is encoded as follows:

11 **Table 30 FacilitiesDirective RETURN RESULT Parameters**

12
13
14
15
16
17
18
19
20
21
22
23
24
25
26

FacilitiesDirective RETURN RESULT Parameters				
Field	Value	Type	Reference	Notes
Identifier	SET [NATIONAL 18]	M	6.3.2.2	
Length	variable octets	M	6.3.2.2	
Contents				
ChannelData (Target)		M	6.5.2.47	a
ConfidentialityModes (Actual)		O	6.5.2.50	b
TDMABurstIndicator (Target)		O	6.5.2.151	c
TDMACHannelData (Target)		O	6.5.2.153	d

Notes:

- 27
28
29
30
31
32
33
34
35
36
37
38
39
40
41
42
43
44
45
46
47
48
49
50
51
52
53
54
55
56
57
58
59
60
- a. This parameter has a length of 0 if a TDMA channel has been assigned.
 - b. Include if ConfidentialityModes was requested to reflect actual assignment.
 - c. May be included if a TDMA channel has been assigned. See parameter definition.
 - d. Include if a TDMA channel has been assigned.

6.4.2.11 FacilitiesDirective2

The FacilitiesDirective2 operation is used to request that the Target MSC initiate the Handoff-Forward task. This operation differs from the FacilitiesDirective operation in its addition of support for CDMA and NAMPS MSs.

The FacilitiesDirective2 operation is initiated with a TCAP INVOKE (LAST). This is carried by a TCAP QUERY WITH PERMISSION package. The Parameter Set is encoded as follows:

Table 31 FacilitiesDirective2 INVOKE Parameters

FacilitiesDirective2 INVOKE Parameters				Timer: HOT
Field	Value	Type	Reference	Notes
Identifier	SET [NATIONAL 18]	M	6.3.2.1	
Length	Variable octets	M	6.3.2.1	
Contents				
BillingID		M	6.5.2.16	
ElectronicSerialNumber		M	6.5.2.63	
InterMSCCircuitID		M	6.5.2.72	
InterSwitchCount		M	6.5.2.73	
MobileIdentificationNumber		M	6.5.2.81	
ServingCellID		M	6.5.2.117	a
TargetCellID		O	6.5.2.148	b
CDMACallMode		O	6.5.2.29	c, d, e
CDMAChannelData (Serving)		O	6.5.2.30	c
CDMA MobileProtocolRevision		O	6.5.2.34	c
CDMA PrivateLongCodeMask		O	6.5.2.36	f
CDMA ServingOneWayDelay		O	6.5.2.38	a, c
CDMA StationClassMark		O	6.5.2.41	c
CDMA TargetMAHOList		O	6.5.2.43	g
CDMA TargetMeasurementList		O	6.5.2.45	h
ChannelData (Serving)		O	6.5.2.47	i
ConfidentialityModes (Desired)		O	6.5.2.50	j
HandoffReason		O	6.5.2.70	k
HandoffState		O	6.5.2.71	l
MSLocation		O	6.5.2.84	c
NAMPS CallMode		O	6.5.2.85	e, m
NAMPS ChannelData (Serving)		O	6.5.2.86	n
SignalingMessageEncryptionKey		O	6.5.2.120	j
StationClassMark		O	6.5.2.143	i, o
TDMABurstIndicator (Serving)		O	6.5.2.151	o
TDMA CallMode		O	6.5.2.152	e, p
TDMA ChannelData (Serving)		O	6.5.2.153	o
VoicePrivacyMask		O	6.5.2.166	q

Notes:

- a. For CDMA, the ServingCellID and CDMA ServingOneWayDelay parameters correspond to the active set member having the shortest signal path to the MS (time reference cell).
- b. Include if AMPS, NAMPS, or TDMA handoff.
- c. Include if CDMA handoff.
- d. Include to indicate the acceptable call mode if other than AMPS (i.e., CDMA or NAMPS).
- e. The values in these parameters shall not contain conflicting information.
- f. This parameter shall be provided if the MS supports CDMA and is authorized to have Voice Privacy and the CDMA PrivateLongCodeMask (CDMA PLCM) parameter is available.
- g. Include for the CDMA MAHO case.
- h. Include for the CDMA non-MAHO case.
- i. Include if an AMPS or NAMPS channel is in use.
- j. Include if MS supports Signaling Message Encryption or Voice Privacy. The parameter shall be carried forward in any subsequent handoff. If one parameter is present, they all must be present.
- k. Include if known.
- l. Include if call is in the awaiting answer or alerting state.
- m. Include to indicate the acceptable call mode if other than AMPS (i.e., NAMPS).
- n. Include if an NAMPS channel is in use.
- o. Include if a TDMA channel is in use.
- p. Include to indicate the acceptable call modes.
- q. This parameter shall be provided if the MS supports TDMA and is authorized to have Voice Privacy and the VoicePrivacyMask (VPMASK) parameter is available.

The FacilitiesDirective2 operation success is reported with a TCAP RETURN RESULT (LAST). This is carried by a TCAP CONVERSATION WITH PERMISSION package. The Parameter Set is encoded as follows:

Table 32 FacilitiesDirective2 RETURN RESULT Parameters

FacilitiesDirective2 RETURN RESULT Parameters				
Field	Value	Type	Reference	Notes
Identifier	SET [NATIONAL 18]	M	6.3.2.2	
Length	variable octets	M	6.3.2.2	
Contents				
	CDMAChannelData (Serving)	O	6.5.2.30	a
	CDMACodeChannelList	O	6.5.2.33	a
	CDMASearchWindow	O	6.5.2.37	a
	ChannelData (Target)	O	6.5.2.47	b
	ConfidentialityModes (Actual)	O	6.5.2.50	c
	NAMPSChannelData (Target)	O	6.5.2.86	d
	TargetCellID	O	6.5.2.148	e
	TDMABurstIndicator (Target)	O	6.5.2.151	f
	TDMAChannelData (Target)	O	6.5.2.153	g

Notes:

- a. Include if target is a CDMA channel.
- b. Include if target is an AMPS or NAMPS channel.
- c. Include to reflect actual assignment if parameter was present in the INVOKE.
- d. Include if target is an NAMPS channel.
- e. Include if the TargetCellID is different than that received in the INVOKE for AMPS, NAMPS, TDMA handoff.
- f. May be included if target is a TDMA channel. See parameter definition.
- g. Include if target is a TDMA channel.

6.4.2.12 FacilitiesRelease

The FacilitiesRelease operation is used to request that allocated resources for a call segment be released.

The FacilitiesRelease operation is initiated with a TCAP INVOKE (LAST). This is carried by a TCAP QUERY WITH PERMISSION package. The Parameter Set is encoded as follows:

Table 33 FacilitiesRelease INVOKE Parameters

FacilitiesRelease INVOKE Parameters				Timer: CTT
Field	Value	Type	Reference	Notes
Identifier	SET [NATIONAL 18]	M	6.3.2.1	
Length	Variable octets	M	6.3.2.1	
Contents				
	InterMSCCircuitID	M	6.5.2.72	
	ReleaseReason	M	6.5.2.111	
	BillingID	O	6.5.2.16	a
	MobileIdentificationNumber	O	6.5.2.81	b

Notes:

- a. Include for reporting the number of segments toward the Anchor MSC (see *DMH*).
- b. Include if required by interconnection agreement.

The FacilitiesRelease operation success is reported with a TCAP RETURN RESULT (LAST). This is carried by a TCAP RESPONSE package. The Parameter Set is encoded as follows:

Table 34 FacilitiesRelease RETURN RESULT Parameters

FacilitiesRelease RETURN RESULT Parameters				
Field	Value	Type	Reference	Notes
Identifier	SET [NATIONAL 18]	M	6.3.2.2	
Length	variable octets	M	6.3.2.2	
Contents				
	BillingID	O	6.5.2.16	a

Notes:

- a. Include for reporting the number of segments toward the Anchor MSC (see *DMH*).

6.4.2.13 FeatureRequest

This operation was named RemoteFeatureControlRequest prior to this revision of the Interim Standard.

The FeatureRequest operation is used to request feature-related treatment on behalf of a registered MS.

The FeatureRequest operation is initiated with a TCAP INVOKE (LAST). This is carried by a TCAP QUERY WITH PERMISSION package. The Parameter Set is encoded as follows:

Table 35 FeatureRequest INVOKE Parameters

FeatureRequest INVOKE Parameters				Timer: FRRT
Field	Value	Type	Reference	Notes
Identifier	SET [NATIONAL 18]	M	6.3.2.1	
Length	variable octets	M	6.3.2.1	
Contents				
Digits (Dialed)		M	6.5.2.58	
ElectronicSerialNumber		M	6.5.2.63	
MobileIdentificationNumber		M	6.5.2.81	
BillingID (Originating)		O	6.5.2.16	a
ChargingAreaInformation		O	6.5.2.J1	J1 *
CallingPartyNumberDigits1		O	6.5.2.21	b
CallingPartyNumberDigits2		O	6.5.2.22	b
CallingPartySubaddress		O	6.5.2.25	b
CarrierIdentificationCode		O	6.5.2.J2	J1 *
ConferenceCallingIndicator		O	6.5.2.49	c
MobileDirectoryNumber		O	6.5.2.80	d
MSCID (Serving)		O	6.5.2.82	e
MSCIdentificationNumber		O	6.5.2.83	b
OneTimeFeatureIndicator		O	6.5.2.88	f
PC_SSN		O	6.5.2.93	g
SenderIdentificationNumber		O	6.5.2.116	h
TransactionCapability		O	6.5.2.160	i

Notes:

- a. Include for recording purposes or for call correlation (see *DMH*).
- b. Include if applicable.
- c. Include to indicate the number of conferees already in the call.
- d. Include if available for recording purposes (see *DMH*).
- e. Include to identify the Anchor MSC. (This may become the Originating MSC for subsequent call redirection.)

1
2
3
4
5
6
7
8
9
10
11
12
13
14
15
16
17
18
19
20
21
22
23
24
25
26
27
28
29
30
31
32
33
34
35
36
37
38
39
40
41
42
43
44
45
46
47
48
49
50
51
52
53
54
55
56
57
58
59
60

- f. Include if any OneTimeFeatureIndicator parameter status bits are set (i.e., have value of *I*).
- g. Include if SS7 may be used for subsequent call redirection.
- h. Include to identify the functional entity sending the message.
- i. Include on *IS-41-C* or later.
- J1. Include for Interconnection charge billing system.

*

The FeatureRequest operation success is reported with a TCAP RETURN RESULT (LAST). This is carried by a TCAP RESPONSE package. The Parameter Set is encoded as follows:

Table 36 FeatureRequest RETURN RESULT Parameters

FeatureRequest RETURN RESULT Parameters				
Field	Value	Type	Reference	Notes
Identifier	SET [NATIONAL 18]	M	6.3.2.2	
Length	variable octets	M	6.3.2.2	
Contents				
FeatureResult		M	6.5.2.67	
AccessDeniedReason		O	6.5.2.1	a
ActionCode		O	6.5.2.2	b
AnnouncementList		O	6.5.2.6	c
CallingPartyNumberString1		O	6.5.2.23	d
CallingPartyNumberString2		O	6.5.2.24	d
CallingPartySubaddress		O	6.5.2.25	d
CarrierDigits		O	6.5.2.28	d
ConferenceCallingIndicator		O	6.5.2.49	e
Digits (Dialed)		O	6.5.2.58	f
DMH_AccountCodeDigits		O	6.5.2.59	g
DMH_AlternateBillingDigits		O	6.5.2.60	g
DMH_BillingDigits		O	6.5.2.61	g
DMH_RedirectionIndicator		O	6.5.2.62	d
GroupInformation		O	6.5.2.69	h
MobileDirectoryNumber		O	6.5.2.80	g
NoAnswerTime		O	6.5.2.87	d
OneTimeFeatureIndicator		O	6.5.2.88	i
PACAIndicator		O	6.5.2.91	j
PilotNumber		O	6.5.2.95	h
RedirectingNumberDigits		O	6.5.2.107	d
RedirectingNumberString		O	6.5.2.108	d
RedirectingSubaddress		O	6.5.2.109	d
RoutingDigits		O	6.5.2.114	d
TerminationList		O	6.5.2.156	k
TerminationTriggers		O	6.5.2.159	d

Notes:

- a. Include if access is denied. If included, no other optional parameters shall be included (with the exception of the AnnouncementList parameter).
- b. Include if action to be performed is not implied through presence of other parameters.
- c. Include if provision of one or more tones or announcements is required.
- d. Include if applicable.

1
2
3
4
5
6
7
8
9
10
11
12
13
14
15
16
17
18
19
20
21
22
23
24
25
26
27
28
29
30
31
32
33
34
35
36
37
38
39
40
41
42
43
44
45
46
47
48
49
50
51
52
53
54
55
56
57
58
59
60

- e. Include to direct that ongoing call be transformed into a .
- f. Include if digits remain to be analyzed by the MSC.
- g. Include if applicable and for recording purposes (see *DMH*),
- h. Include for multileg calls.
- i. Include if modification to normal feature processing is required for call in progress.
- j. Include to indicate PACA priority level.
- k. Include if call routing is required.

6.4.2.14 FlashRequest

The FlashRequest operation is used to forward a flash received from an MS engaged in a call toward the Anchor MSC (possibly via one or more Tandem MSCs).

The FlashRequest operation is initiated with a TCAP INVOKE (LAST). This is carried by a TCAP QUERY WITH PERMISSION package. The Parameter Set is encoded as follows:

Table 37 FlashRequest INVOKE Parameters

FlashRequest INVOKE Parameters				Timer: FRT
Field	Value	Type	Reference	Notes
Identifier	SET [NATIONAL 18]	M	6.3.2.1	
Length	variable octets	M	6.3.2.1	
Contents				
Digits (Dialed)		M	6.5.2.58	a
InterMSCCircuitID		M	6.5.2.72	
MobileIdentificationNumber		M	6.5.2.81	
ConfidentialityModes (Actual)		O	6.5.2.50	b
ElectronicSerialNumber		O	6.5.2.63	

Notes:

- a. The Digits parameter is sent non-encrypted.
- b. Include if the SignalingMessageEncryptionKey parameter was provided to the Serving MSC.

The FlashRequest operation success is reported with a TCAP RETURN RESULT (LAST). This is carried by a TCAP RESPONSE package. The Parameter Set is encoded as follows:

Table 38 FlashRequest RETURN RESULT Parameters

FlashRequest RETURN RESULT Parameters				
Field	Value	Type	Reference	Notes
Identifier	SET [NATIONAL 18]	M	6.3.2.2	
Length	zero octets	M	6.3.2.2	
Contents				

6.4.2.15 HandoffBack

See HandoffBack2 for enhanced use.

The HandoffBack operation is used by the Serving MSC to request that the Target MSC initiate the Handoff-Back task. This task is used to handoff a call to a Target MSC to which the Serving MSC is already connected, for the call in question, via an inter-MSC trunk.

The HandoffBack operation is initiated with a TCAP INVOKE (LAST). This is carried by a TCAP QUERY WITH PERMISSION package. The Parameter Set is encoded as follows:

Table 39 HandoffBack INVOKE Parameters

HandoffBack INVOKE Parameters				Timer: HOT
Field	Value	Type	Reference	Notes
Identifier	SET [NATIONAL 18]	M	6.3.2.1	
Length	variable octets	M	6.3.2.1	
Contents				
ChannelData (Serving)		M	6.5.2.47	a
InterMSCCircuitID		M	6.5.2.72	
MobileIdentificationNumber		M	6.5.2.81	
ServingCellID		M	6.5.2.117	
TargetCellID		M	6.5.2.148	
BillingID		O	6.5.2.16	b
ConfidentialityModes (Desired)		O	6.5.2.50	c
HandoffReason		O	6.5.2.70	d
HandoffState		O	6.5.2.71	e
SignalingMessageEncryptionKey		O	6.5.2.120	c, f
TDMA Burst Indicator (Serving)		O	6.5.2.151	g
TDMA Call Mode		O	6.5.2.152	h
TDMA Channel Data (Serving)		O	6.5.2.153	g
Voice Privacy Mask		O	6.5.2.166	i

Notes:

- a. This parameter has a length of 0 if a TDMA channel is in use.
- b. Include to maintain segment count.
- c. Include if MS supports Signaling Message Encryption or Voice Privacy. The parameter shall be carried forward in any subsequent handoff.
- d. Include if known.
- e. Include if the call is in the awaiting answer or alerting state.
- f. Include if Signaling Message Encryption may apply. This parameter shall be carried forward in any subsequent handoff.
- g. Include if a TDMA channel is in use.

- h. Include to indicate acceptable call modes.
- i. Include if the Voice Privacy may apply. This parameter shall be carried forward in any subsequent handoff.

The HandoffBack operation success is reported with a TCAP RETURN RESULT (LAST). This is carried by a TCAP RESPONSE package. The Parameter Set is encoded as follows:

Table 40 HandoffBack RETURN RESULT Parameters

HandoffBack RETURN RESULT Parameters				
Field	Value	Type	Reference	Notes
Identifier	SET [NATIONAL 18]	M	6.3.2.2	
Length	variable octets	M	6.3.2.2	
Contents				
ChannelData (Target)		M	6.5.2.47	a
ConfidentialityModes (Actual)		O	6.5.2.50	b
TDMABurstIndicator (Target)		O	6.5.2.151	c
TDMACHannelData (Target)		O	6.5.2.153	d

Notes:

- a. This parameter has a length of 0 if a TDMA channel has been assigned.
- b. Include if ConfidentialityModes was requested to reflect actual assignment.
- c. May be included if a TDMA channel has been assigned. See parameter definition.
- d. Include if a TDMA channel has been assigned.

6.4.2.16 HandoffBack2

The HandoffBack2 operation is used by the Serving MSC to request that the Target MSC initiate the Handoff-Back task. This task is used to handoff a call to a Target MSC to which the Serving MSC is already connected, for the call in question, via an inter-MSC trunk. This operation differs from the HandoffBack operation in its addition of support for CDMA and NAMPS MSs.

The HandoffBack2 operation is initiated with a TCAP INVOKE (LAST). This is carried by a TCAP QUERY WITH PERMISSION package. The Parameter Set is encoded as follows:

Table 41 HandoffBack2 INVOKE Parameters

HandoffBack2 INVOKE Parameters				Timer: HOT
Field	Value	Type	Reference	Notes
Identifier	SET [NATIONAL 18]	M	6.3.2.1	
Length	Variable octets	M	6.3.2.1	
Contents				
BillingID		M	6.5.2.16	
InterMSCCircuitID		M	6.5.2.72	
MobileIdentificationNumber		M	6.5.2.81	
ServingCellID		M	6.5.2.117	a
TargetCellID		O	6.5.2.148	b
CDMACallMode		O	6.5.2.29	c, d, e
CDMAChannelData (Serving)		O	6.5.2.30	c
CDMAMobileProtocolRevision		O	6.5.2.34	c
CDMAPrivateLongCodeMask		O	6.5.2.36	f
CDMAServingOneWayDelay		O	6.5.2.38	a, c
CDMAStationClassMark		O	6.5.2.41	c
CDMATargetMAHOList		O	6.5.2.43	g
CDMATargetMeasurementList		O	6.5.2.45	h
ChannelData (Serving)		O	6.5.2.47	i
ConfidentialityModes (Desired)		O	6.5.2.50	j
HandoffReason		O	6.5.2.70	k
HandoffState		O	6.5.2.71	l
MSLocation		O	6.5.2.84	c
NAMPSCallMode		O	6.5.2.85	e, m
NAMPSCChannelData (Serving)		O	6.5.2.86	n
SignalingMessageEncryptionKey		O	6.5.2.120	j
TDMABurstIndicator (Serving)		O	6.5.2.151	o
TDMACallMode		O	6.5.2.152	e, p
TDMACHannelData (Serving)		O	6.5.2.153	o
VoicePrivacyMask		O	6.5.2.166	q

Notes:

- a. For CDMA, the ServingCellID and CDMA ServingOneWayDelay parameters correspond to the active set member having the shortest signal path to the MS (time reference cell).
- b. Include if AMPS, NAMPS or TDMA handoff.
- c. Include if CDMA handoff.
- d. Include to indicate the acceptable call mode of other than AMPS (i.e., CDMA or NAMPS).
- e. The values in these parameters shall not contain conflicting information.
- f. This parameter shall be provided if the MS supports CDMA and is authorized to have Voice Privacy and the CDMA PrivateLongCodeMask (CDMA PLCM) parameter is available.
- g. Include for the CDMA MAHO case.
- h. Include for the CDMA non-MAHO case.
- i. Include if an AMPS or NAMPS channel is in use.
- j. Include if MS supports Signaling Message Encryption or Voice Privacy. The parameter shall be carried forward in any subsequent handoff. If one parameter is present, they all must be present.
- k. Include if known.
- l. Include if the call is in the awaiting answer or alerting state.
- m. Include to indicate the acceptable call mode if other than AMPS (i.e., NAMPS).
- n. Include if an NAMPS channel is in use.
- o. Include if a TDMA channel is in use.
- p. Include to indicate acceptable call modes.
- q. This parameter shall be provided if the MS supports TDMA and is authorized to have Voice Privacy and the VoicePrivacyMask (VPMASK) parameter is available.

The HandoffBack2 operation success is reported with a TCAP RETURN RESULT (LAST). This is carried by a TCAP RESPONSE package. The Parameter Set is encoded as follows:

Table 42 HandoffBack2 RETURN RESULT Parameters

HandoffBack2 RETURN RESULT Parameters				
Field	Value	Type	Reference	Notes
Identifier	SET [NATIONAL 18]	M	6.3.2.2	
Length	Variable octets	M	6.3.2.2	
Contents				
	CDMAChannelData (Target)	O	6.5.2.30	a
	CDMACodeChannelList	O	6.5.2.33	a
	CDMASearchWindow	O	6.5.2.37	a
	ChannelData (Target)	O	6.5.2.47	b
	ConfidentialityModes (Actual)	O	6.5.2.50	c
	NAMPSChannelData (Target)	O	6.5.2.86	d
	TargetCellID	O	6.5.2.148	e
	TDMABurstIndicator (Target)	O	6.5.2.151	f
	TDMAChannelData (Target)	O	6.5.2.153	g

Notes:

- a. Include if target is a CDMA channel.
- b. Include if target is an AMPS or NAMPS channel.
- c. Include to reflect actual assignment if parameter was present in the INVOKE.
- d. Include if target is an NAMPS channel.
- e. Include if the TargetCellID is different than that received in the INVOKE for AMPS, NAMPS, TDMA handoff.
- f. May be included if target is a TDMA channel. See parameter definition.
- g. Include if target is a TDMA channel.

6.4.2.17 HandoffMeasurementRequest

See HandoffMeasurementRequest2 for enhanced use.

The HandoffMeasurementRequest operation is sent by the Serving MSC to any adjacent MSCs to request a signal quality measurement on the specified channel.

The HandoffMeasurementRequest operation is initiated with a TCAP INVOKE (LAST). This is carried by a TCAP QUERY WITH PERMISSION package. The Parameter Set is encoded as follows:

Table 43 HandoffMeasurementRequest INVOKE Parameters

HandoffMeasurementRequest INVOKE Parameters				Timer: LMMRT
Field	Value	Type	Reference	Notes
Identifier	SET [NATIONAL 18]	M	6.3.2.1	
Length	Variable octets	M	6.3.2.1	
Contents				
ChannelData (Serving)		M	6.5.2.47	a
ServingCellID		M	6.5.2.117	
StationClassMark		M	6.5.2.143	
TDMACallMode		O	6.5.2.152	b
TDMAChannelData (Serving)		O	6.5.2.153	c

Notes:

- This parameter has a length of 0 if a TDMA channel measurement is requested.
- Include to indicate the current call modes.
- Include if a TDMA channel measurement is requested.

The HandoffMeasurementRequest operation success is reported with a TCAP RETURN RESULT (LAST). This is carried by a TCAP RESPONSE package. The Parameter Set is encoded as follows:

Table 44 HandoffMeasurementRequest RETURN RESULT Parameters

HandoffMeasurementRequest RETURN RESULT Parameters				
Field	Value	Type	Reference	Notes
Identifier	SET [NATIONAL 18]	M	6.3.2.2	
Length	Variable octets	M	6.3.2.2	
Contents				
SignalQuality		M	6.5.2.121	a
TargetCellID		M	6.5.2.148	a

Notes:

- TargetCellID and SignalQuality parameters must appear in pairs. Multiple pairs may be returned.

6.4.2.18 HandoffMeasurementRequest2

The HandoffMeasurementRequest2 operation is sent by the Serving MSC to any adjacent MSCs to request a signal quality measurement on the specified channel. This operation differs from the HandoffMeasurementRequest operation in its addition of support for CDMA and NAMPS MSs.

The HandoffMeasurementRequest2 operation is initiated with a TCAP INVOKE (LAST). This is carried by a TCAP QUERY WITH PERMISSION package. The Parameter Set is encoded as follows:

Table 45 HandoffMeasurementRequest2 INVOKE Parameters

HandoffMeasurementRequest2 INVOKE				Timer: LMMRT
Field	Value	Type	Reference	Notes
Identifier	SET [NATIONAL 18]	M	6.3.2.1	
Length	variable octets	M	6.3.2.1	
Contents				
ServingCellID		M	6.5.2.117	
CDMACallMode		O	6.5.2.29	a, b
CDMAChannelData (Serving)		O	6.5.2.30	b
CDMAServingOneWayDelay		O	6.5.2.38	b
CDMAStationClassMark		O	6.5.2.41	b
ChannelData (Serving)		O	6.5.2.47	c
MSLocation		O	6.5.2.84	b
NAMPSCallMode		O	6.5.2.85	d
NAMPSCChannelData (Serving)		O	6.5.2.86	e
StationClassMark		O	6.5.2.143	c, f
TDMACallMode		O	6.5.2.152	g
TDMAChannelData (Serving)		O	6.5.2.153	f

Notes:

- a. Include to indicate the current call mode if other than AMPS (i.e., CDMA or NAMPS).
- b. Include if a CDMA channel measurement is requested.
- c. Include if an AMPS or NAMPS channel measurement is requested.
- d. Include to indicate the current call mode if other than AMPS (i.e., NAMPS).
- e. Include if an NAMPS channel measurement is requested.
- f. Include if a TDMA channel measurement is requested.
- g. Include to indicate the current call modes.

The HandoffMeasurementRequest2 operation success is reported with a TCAP RETURN RESULT (LAST). This is carried by a TCAP RESPONSE package. The Parameter Set is encoded as follows:

Table 46 HandoffMeasurementRequest2 RETURN RESULT Parameters

HandoffMeasurementRequest2 RETURN RESULT Parameters				
Field	Value	Type	Reference	Notes
Identifier	SET [NATIONAL 18]	M	6.3.2.2	
Length	Variable octets	M	6.3.2.2	
Contents				
	CDMATargetMeasurementList	O	6.5.2.45	a
	TargetMeasurementList	O	6.5.2.150	b

Notes:

- a. Include for CDMA measurement.
- b. Include for AMPS, NAMPS, or TDMA measurement.

6.4.2.19 HandoffToThird

See HandoffToThird2 for enhanced use.

The HandoffToThird operation is used by the Serving MSC (non-Anchor) to initiate a handoff with path minimization.

The HandoffToThird operation is initiated with a TCAP INVOKE (LAST). This is carried by a TCAP QUERY WITH PERMISSION package. The Parameter Set is encoded as follows:

Table 47 HandoffToThird INVOKE Parameters

HandoffToThird INVOKE Parameters				Timer: HTTT
Field	Value	Type	Reference	Notes
Identifier	SET [NATIONAL 18]	M	6.3.2.1	
Length	variable octets	M	6.3.2.1	
Contents				
ElectronicSerialNumber		M	6.5.2.63	
InterMSCCircuitID		M	6.5.2.72	
InterSwitchCount (Serving)		M	6.5.2.73	
MobileIdentificationNumber		M	6.5.2.81	
MSCID (Target)		M	6.5.2.82	
ServingCellID		M	6.5.2.117	
StationClassMark		M	6.5.2.143	
TargetCellID		M	6.5.2.148	
BillingID		O	6.5.2.16	a
Channe;Data (Serving)		O	6.5.2.47	b
ConfidentialityModes (Desired)		O	6.5.2.50	c
HandoffReason		O	6.5.2.70	d
SignalingMessageEncryptionKey		O	6.5.2.120	c
TDMABurstIndicator (Serving)		O	6.5.2.151	e
TDMACallMode		O	6.5.2.152	f
TDMAChannelData (Serving)		O	6.5.2.153	e
VoicePrivacyMask		O	6.5.2.166	g

Notes:

- a. Include to maintain segment count.
- b. Include if the current call mode is AMPS.
- c. Include if MS supports Signaling Message Encryption or Voice Privacy. The parameter shall be carried forward in any subsequent handoff. If one parameter is present, they all must be present.
- d. Include if known.
- e. Include if a TDMA channel is in use.
- f. Include to indicate the acceptable call modes.

- g. Include if Voice Privacy may apply.

The HandoffToThird operation success is reported with a TCAP RETURN RESULT (LAST). This is carried by a TCAP RESPONSE package. The Parameter Set is encoded as follows:

Table 48 HandoffToThird RETURN RESULT Parameters

HandoffToThird RETURN RESULT Parameters				
Field	Value	Type	Reference	Notes
Identifier	SET [NATIONAL 18]	M	6.3.2.2	
Length	variable octets	M	6.3.2.2	
Contents				
ChannelData (Target)		O	6.5.2.47	a
ConfidentialityModes (Actual)		O	6.5.2.50	b
TDMABurstIndicator (Target)		O	6.5.2.151	c
TDMAChannelData (Target)		O	6.5.2.153	d

Notes:

- a. Include if an AMPS channel has been assigned.
- b. Include to reflect actual assignment if the ConfidentialityModes parameter was present in the INVOKE.
- c. May be included if a TDMA channel has been assigned.
- d. Include if a TDMA channel has been assigned.

6.4.2.20 HandoffToThird2

The HandoffToThird2 operation is used by the Serving MSC (non-Anchor) to initiate a handoff with path minimization. This operation differs from the HandoffToThird operation in its support of dual-mode CDMA and NAMPS MSs.

The HandoffToThird2 operation is initiated with a TCAP INVOKE (LAST). This is carried by a TCAP QUERY WITH PERMISSION package. The Parameter Set is encoded as follows:

Table 49 HandoffToThird2 INVOKE Parameters

HandoffToThird2 INVOKE Parameters				Timer: HTTT
Field	Value	Type	Reference	Notes
Identifier	SET [NATIONAL 18]	M	6.3.2.1	
Length	Variable octets	M	6.3.2.1	
Contents				
BillingID		M	6.5.2.16	
ElectronicSerialNumber		M	6.5.2.63	
InterMSCCircuitID		M	6.5.2.72	
InterSwitchCount (Serving)		M	6.5.2.73	
MobileIdentificationNumber		M	6.5.2.81	
MSCID (Target)		M	6.5.2.82	
ServingCellID		M	6.5.2.117	a
TargetCellID		O	6.5.2.148	b
CDMACallMode		O	6.5.2.29	c, d, e
CDMAChannelData (Serving)		O	6.5.2.30	c
CDMAMobileProtocolReason		O	6.5.2.34	c
CDMAPrivateLongCodeMask		O	6.5.2.36	f
CDMAServingOneWayDelay		O	6.5.2.38	a, c
CDMAStationClassMark		O	6.5.2.41	c
CDMATargetMAHOList		O	6.5.2.43	g
CDMATargetMeasurementList		O	6.5.2.45	h
ChannelData (Serving)		O	6.5.2.47	i
ConfidentialityModes (Desired)		O	6.5.2.50	j
HandoffReason		O	6.5.2.70	k
MSLocation		O	6.5.2.84	c
NAMPSCallMode		O	6.5.2.85	e, l
NAMPSCChannelData (Serving)		O	6.5.2.86	m
SignalingMessageEncryptionKey		O	6.5.2.120	j
StationClassMark		O	6.5.2.143	i, m, n
TDMABurstIndicator (Serving)		O	6.5.2.151	n
TDMACallMode		O	6.5.2.152	n, o
TDMAChannelData (Serving)		O	6.5.2.153	n
VoicePrivacyMask		O	6.5.2.166	p

Notes:

- a. For CDMA, the ServingCellID and CDMA ServingOneWayDelay parameters correspond to the active set member having the shortest signal path to the MS (time reference cell).
- b. Include if AMPS, NAMPS or TDMA handoff.
- c. Include if CDMA handoff.
- d. Include to indicate the acceptable call modes if other than AMPS (i.e., CDMA or NAMPS).
- e. The values in these parameters shall not contain conflicting information.
- f. This parameter shall be provided if the MS supports CDMA and is authorized to have Voice Privacy and the CDMA PrivateLongCodeMask (CDMA PLCM) parameter is available.
- g. Include for the CDMA MAHO case.
- h. Include for the CDMA non-MAHO case.
- i. Include if an AMPS or NAMPS channel is in use.
- j. Include if MS supports Signaling Message Encryption or Voice Privacy. The parameter shall be carried forward in any subsequent handoff. If one parameter is present, they all must be present.
- k. Include if known.
- l. Include to indicate the current call mode if other than AMPS (i.e., NAMPS).
- m. Include if an NAMPS channel is in use.
- n. Include if a TDMA channel is in use.
- o. Include to indicate the acceptable call modes.
- p. This parameter shall be provided if the MS supports TDMA and is authorized to have Voice Privacy and the VoicePrivacyMask (VPMASK) parameter is available.

The HandoffToThird2 operation success is reported with a TCAP RETURN RESULT (LAST). This is carried by a TCAP RESPONSE package. The Parameter Set is encoded as follows:

Table 50 HandoffToThird2 RETURN RESULT Parameters

HandoffToThird2 RETURN RESULT Parameters				
Field	Value	Type	Reference	Notes
Identifier	SET [NATIONAL 18]	M	6.3.2.2	
Length	variable octets	M	6.3.2.2	
Contents				
	CDMAChannelData (Target)	O	6.5.2.30	a
	CDMACodeChannelList	O	6.5.2.33	a
	CDMASearchWindow	O	6.5.2.37	a
	ChannelData (Target)	O	6.5.2.47	b
	ConfidentialityModes (Actual)	O	6.5.2.50	c
	NAMPSChannelData (Target)	O	6.5.2.86	d
	TargetCellID	O	6.5.2.148	e
	TDMABurstIndicator (Target)	O	6.5.2.151	f
	TDMAChannelData (Target)	O	6.5.2.153	g

Notes:

- a. Include if target is a CDMA channel.
- b. Include if target is an AMPS or NAMPS channel.
- c. Include to reflect actual assignment if parameter was present in the INVOKE.
- d. Include if target is an NAMPS channel.
- e. Include if the TargetCellID is different than that received in the INVOKE for AMPS, NAMPS, TDMA handoff.
- f. May be included if target is a TDMA channel. See parameter definition.
- g. Include if target is a TDMA channel.

6.4.2.21 InformationDirective

The InformationDirective operation is used by the HLR to direct the serving system to provide a specified notification to an idle MS.

The InformationDirective operation is initiated with a TCAP INVOKE (LAST). This is carried by a TCAP QUERY WITH PERMISSION package. The Parameter Set is encoded as follows:

Table 51 InformationDirective INVOKE Parameters

InformationDirective INVOKE Parameters				Timer: IDT
Field	Value	Type	Reference	Notes
Identifier	SET [NATIONAL 18]	M	6.3.2.1	
Length	Variable octets	M	6.3.2.1	
Contents				
	ElectronicSerialNumber	M	6.5.2.63	
	MobileIdentificationNumber	M	6.5.2.81	
	AlertCode	O	6.5.2.3	a
	AnnouncementList	O	6.5.2.6	b
	CallingPartyNumberString1	O	6.5.2.23	c
	CallingPartyNumberString2	O	6.5.2.24	c
	CallingPartySubaddress	O	6.5.2.25	c
	RedirectingNumberString	O	6.5.2.108	c
	RedirectingSubaddress	O	6.5.2.109	c
	SenderIdentificationNumber	O	6.5.2.116	d

Notes:

- a. Include if the MS is to be alerted.
- b. Include if one or more tones or announcements are to be applied to the MS.
- c. Include if authorized and available.
- d. Include to identify the functional entity sending the message.

The InformationDirective operation success is reported with a TCAP RETURN RESULT (LAST). This is carried by a TCAP RESPONSE package. The Parameter Set is encoded as follows:

Table 52 InformationDirective RETURN RESULT Parameters

InformationDirective RETURN RESULT Parameters				
Field	Value	Type	Reference	Notes
Identifier	SET [NATIONAL 18]	M	6.3.2.2	
Length	Variable octets	M	6.3.2.2	
Contents				
AlertResult		O	6.5.2.4	a
ChargingAreaInformation		O	6.5.2.J1	J1 *
CarrierIdentificationCode		O	6.5.2.J2	J1 *

Notes:

- a. Include if requested via AlertCode parameter in the InformationDirective INVOKE.
- J1. Include for Interconnection charge billing system. *

6.4.2.22 InformationForward

The InformationForward operation is used by the Anchor MSC to transfer information concerning the served MS to the Serving MSC after handoff (e.g., a message waiting status change).

The InformationForward operation is initiated with a TCAP INVOKE (LAST). This is carried by a TCAP QUERY WITH PERMISSION package. The Parameter Set is encoded as follows:

Table 53 InformationForward INVOKE Parameters

InformationForward INVOKE Parameters				Timer: IFT
Field	Value	Type	Reference	Notes
Identifier	SET [NATIONAL 18]	M	6.3.2.1	
Length	variable octets	M	6.3.2.1	
Contents				
InterMSCCircuitID		M	6.5.2.72	
MobileIdentificationNumber		M	6.5.2.81	
AlertCode		O	6.5.2.3	a
AnnouncementList		O	6.5.2.6	a
CallingPartyNumberString1		O	6.5.2.23	b
CallingPartyNumberString2		O	6.5.2.24	b
CallingPartySubaddress		O	6.5.2.25	b
ElectronicSerialNumber		O	6.5.2.63	a
MessageWaitingNotificationCount		O	6.5.2.78	a
MessageWaitingNotificationType		O	6.5.2.79	a
RedirectingNumberString		O	6.5.2.108	b
RedirectingSubaddress		O	6.5.2.109	b

Notes:

- a. Include if appropriate.
- b. Include if the MS is authorized for CNIP.

The InformationForward operation success is reported with a TCAP RETURN RESULT (LAST). This is carried by a TCAP RESPONSE package. The Parameter Set is encoded as follows:

Table 54 InformationForward RETURN RESULT Parameters

InformationForward RETURN RESULT Parameters				
Field	Value	Type	Reference	Notes
Identifier	SET [NATIONAL 18]	M	6.3.2.2	
Length	variable octets	M	6.3.2.2	
Contents				
AlertResult		O	6.5.2.4	a

Notes:

- a. Include if AlertCode parameter request it in the InformationForward INVOKE.

1
2
3
4
5
6
7
8
9
10
11
12
13
14
15
16
17
18
19
20
21
22
23
24
25
26
27
28
29
30
31
32
33
34
35
36
37
38
39
40
41
42
43
44
45
46
47
48
49
50
51
52
53
54
55
56
57
58
59
60

6.4.2.23 InterSystemAnswer

The InterSystemAnswer operation can be used in two types of scenarios:

- 1) It is used by a Border MSC to notify the Serving MSC that an MS has successfully answered an alert in the Border MSC.
- 2) It is used by either an Anchor MSC or a Serving MSC after handoff has occurred to indicate that a call in the awaiting answer or alerting state has been answered.

The InterSystemAnswer operation is initiated with a TCAP INVOKE (LAST). This is carried by a TCAP QUERY WITH PERMISSION package. The Parameter Set is encoded as follows:

Table 55 InterSystemAnswer INVOKE Parameters

InterSystemAnswer INVOKE Parameters				Timer: ISAT
Field	Value	Type	Reference	Notes
Identifier	SET [NATIONAL 18]	M	6.3.2.1	
Length	variable octets	M	6.3.2.1	
Contents				
	InterMSCCircuitID	M	6.5.2.72	
		M	6.5.2.81	
		O	6.5.2.63	a

Notes:

- a. Include if appropriate.

The InterSystemAnswer operation success is reported with a TCAP RETURN RESULT (LAST). This is carried by a TCAP RESPONSE package. The Parameter Set is encoded as follows:

Table 56 InterSystemAnswer RETURN RESULT Parameters

InterSystemAnswer RETURN RESULT Parameters				
Field	Value	Type	Reference	Notes
Identifier	SET [NATIONAL 18]	M	6.3.2.2	
Length	zero octets	M	6.3.2.2	
Contents				

6.4.2.24 InterSystemPage

The InterSystemPage operation is used by a Serving MSC to request a Border MSC to either (a) page an MS, or (b) listen for a page response from an MS, in the Border MSC prior to Call Delivery. If the MS's presence is confirmed on the Border MSC, the MS should be registered in the Border MSC and the call is delivered directly to the Border MSC.

The InterSystemPage operation is initiated with a TCAP INVOKE (LAST). This is carried by a TCAP QUERY WITH PERMISSION package. The Parameter Set is encoded as follows:

Table 57 InterSystemPage INVOKE Parameters

InterSystemPage INVOKE Parameters				Timer: ISPR
Field	Value	Type	Reference	Notes
Identifier	SET [NATIONAL 18]	M	6.3.2.1	
Length	variable octets	M	6.3.2.1	
Contents				
BillingID (Originating)		M	6.5.2.16	
ElectronicSerialNumber		M	6.5.2.63	
MobileIdentificationNumber		M	6.5.2.81	
DMH_AccountCodeDigits		O	6.5.2.59	a
AlertCode		O	6.5.2.3	a
CallingPartyNumberString1		O	6.5.2.23	a
CallingPartyNumberString2		O	6.5.2.24	a
CallingPartySubaddress		O	6.5.2.25	a
CDMASlotCycleIndex		O	6.5.2.40	b
CDMAStationClassMark		O	6.5.2.41	c
DMH_AlternateBillingDigits		O	6.5.2.60	a
DMH_BillingDigits		O	6.5.2.61	a
ExtendedMSCID (Serving MSC)		O	6.5.2.64	d
ExtendedSystemMyTypeCode (Serving MSC)		O	6.5.2.65	e
LegInformation		O	6.5.2.75	f
LocationAreaID		O	6.5.2.77	f
MobileDirectoryNumber		O	6.5.2.80	a
MSCID (Originating MSC)		O	6.5.2.82	g
MSCIdentificationNumber		O	6.5.2.83	f
OneTimeFeatureIdicator		O	6.5.2.88	f
PageIndicator		O	6.5.2.92	h
PC_SSN (Originating MSC)		O	6.5.2.93	i
PilotBillingID		O	6.5.2.94	j
PilotNumber		O	6.5.2.95	k
RedirectingNumberString		O	6.5.2.108	a
RedirectingSubaddress		O	6.5.2.109	a
SenderIdentificationNumber		O	6.5.2.116	f
SystemMyTypeCode (Originating MSC)		O	6.5.2.147	l
TerminationTreatment		O	6.5.2.158	f
TerminationTriggers		O	6.5.2.159	a

Notes:

- a. Include if available (i.e., provided in the associated RoutingRequest INVOKE).
- b. Included when the Serving MSC knows that the MS is operating in CDMA Slotted Mode.
- c. Include if a CDMA channel is in use.
- d. Include to identify serving system.

- 1 e. Include to identify serving system manufacturer.
 2
 3 f. Include if known.
 4
 5 g. Include to identify originating system.
 6
 7 h. Include if request is to listen only. May include if request is to page.
 8
 9 i. Include if available for subsequent call redirection.
 10
 11 j. Include if appropriate.
 12
 13 k. Include on a multileg call.
 14
 15 l. Include to identify originating system manufacturer.

16 The InterSystemPage operation success is reported with a TCAP RETURN RESULT
 17 (LAST). This is carried by a TCAP RESPONSE package. The Parameter Set is encoded
 18 as follows:
 19

20 **Table 58 InterSystemPage RETURN RESULT Parameters**

InterSystemPage RETURN RESULT Parameters				
Field	Value	Type	Reference	Notes
Identifier	SET [NATIONAL 18]	M	6.3.2.2	
Length	variable octets	M	6.3.2.2	
Contents				
AccessDeniedReason		O	6.5.2.1	a
BillingID (Terminating)		O	6.5.2.16	b, c
ConditionallyDeniedReason		O	6.5.2.48	d
Digits (Destination)		O	6.5.2.58	c
ExtendedMSCID (Border MSC)		O	6.5.2.64	c
ExtendedSystemMyTypeCode (Border MSC)		O	6.5.2.65	c
MSCIdentificationNumber		O	6.5.2.83	e
PC_SSN (Border MSC)		O	6.5.2.93	f

21
22
23
24
25
26
27
28
29
30
31
32
33
34
35
36
37
38
39
40
41 Notes:

- 42 a. Include if access may be denied.
 43
 44 b. Required for recording purposes (see *DMH*).
 45
 46 c. If one parameter is present, they all must be present.
 47
 48 d. Include if Call Waiting is possible.
 49
 50 e. Include to identify the Border MSC.
 51
 52 f. Include if Digits (Destination) parameter is provided, and SS7 is used.
 53
 54
 55
 56
 57
 58
 59
 60

6.4.2.25 InterSystemPage2

The InterSystemPage2 operation is used by a Serving MSC that has received a call via a TLDN to request a Border MSC to either (a) page an MS, or (b) listen for a page response from an MS, in the Border MSC. If an MS's presence is confirmed in the Border MSC, the call is terminated to the Border MSC via intersystem trunk facilities.

The InterSystemPage2 operation is initiated with a TCAP INVOKE (LAST). This is carried by a TCAP QUERY WITH PERMISSION package. The Parameter Set is encoded as follows:

Table 59 InterSystemPage2 INVOKE Parameters

InterSystemPage2 INVOKE Parameters				Timer: ISPR
Field	Value	Type	Reference	Notes
Identifier	SET [NATIONAL 18]	M	6.3.2.1	
Length	variable octets	M	6.3.2.1	
Contents				
BillingID (Originating)		M	6.5.2.16	
ElectronicSerialNumber		M	6.5.2.63	
MobileIdentificationNumber		M	6.5.2.81	
AlertCode		O	6.5.2.3	a
CallingPartyNumberString1		O	6.5.2.23	b
CallingPartyNumberString2		O	6.5.2.24	b
CallingPartySubaddress		O	6.5.2.25	b
CDMASlotCycleIndex		O	6.5.2.40	c
CDMAStationClassMark		O	6.5.2.41	d
LocationAreaID		O	6.5.2.77	e
MobileDirectoryNumber		O	6.5.2.80	a
PageIndicator		O	6.5.2.92	f
RedirectingNumberString		O	6.5.2.108	b
RedirectingSubaddress		O	6.5.2.109	b

Notes:

- a. Include if available (i.e., provided in associated RoutingRequest INVOKE).
- b. Include if available (i.e., provided in associated RoutingRequest INVOKE) and the MS is authorized for CNIP.
- c. Included when the Serving MSC knows that the MS is operating in CDMA Slotted Mode.
- d. Include if a CDMA channel is in use.
- e. Include if known.
- f. Include if request is to listen only. May include if request is to page.

The InterSystemPage2 operation success is reported with a TCAP RETURN RESULT (LAST). This is carried by a TCAP RESPONSE package. The Parameter Set is encoded as follows:

Table 60 InterSystemPage2 RETURN RESULT Parameters

InterSystemPage2 RETURN RESULT Parameters				
Field	Value	Type	Reference	Notes
Identifier	SET [NATIONAL 18]	M	6.3.2.2	
Length	variable octets	M	6.3.2.2	
Contents				
	AccessDeniedReason	O	6.5.2.1	a
	AuthenticationResponse	O	6.5.2.10	b
	CallHistoryCount	O	6.5.2.18	b
	RANDC	O	6.5.2.100	c
	RandomVariable	O	6.5.2.101	d
	SystemAccessType	O	6.5.2.145	b

Notes:

- a. Include if MS is not available.
- b. Include if authentication parameters were received from the MS.
- c. Include if authentication parameters were received from the MS and the value of RAND used by the MS to compute AUTHR cannot be determined.
- d. Include if authentication parameters were received from the MS and the value of RAND used by the MS to compute AUTHR was determined.

6.4.2.26 InterSystemSetup

The InterSystemSetup operation is used by a Serving MSC to request a Border MSC to perform call setup actions; i.e., connect the voice channel in which the MS confirmation has been received to the intersystem trunk facility specified by the Serving MSC.

The InterSystemSetup operation is initiated with a TCAP INVOKE (LAST). This is carried by a TCAP QUERY WITH PERMISSION package. The Parameter Set is encoded as follows:

Table 61 InterSystemSetup INVOKE Parameters

InterSystemSetup INVOKE Parameters				Timer: ISSRT
Field	Value	Type	Reference	Notes
Identifier	SET [NATIONAL 18]	M	6.3.2.1	
Length	variable octets	M	6.3.2.1	
Contents				
BillingID		M	6.5.2.16	
ElectronicSerialNumber		M	6.5.2.63	
InterMSCCircuitID		M	6.5.2.72	
MobileIdentificationNumber		M	6.5.2.81	
CDMAPrivateLongCodeMask		O	6.5.2.36	a
SignalingMessageEncryptionKey		O	6.5.2.120	a
VoicePrivacyMask		O	6.5.2.166	a

Notes:

- a. Include if available.

The InterSystemSetup operation success is reported with a TCAP RETURN RESULT (LAST). This is carried by a TCAP QUERY WITH PERMISSION package. The Parameter Set is encoded as follows:

Table 62 InterSystemSetup RETURN RESULT Parameters

InterSystemSetup RETURN RESULT Parameters				
Field	Value	Type	Reference	Notes
Identifier	SET [NATIONAL 18]	M	6.3.2.2	
Length	variable octets	M	6.3.2.2	
Contents				
SetupResult		O	6.5.2.118	a

Notes:

- a. Include to report the result of the operation.

6.4.2.27 LocationRequest

The LocationRequest operation is used by an Originating MSC to obtain call treatment instructions from the HLR. The call is identified by the dialed MS address digits received by the Originating MSC.

The LocationRequest operation is initiated with a TCAP INVOKE (LAST). This is carried by a TCAP QUERY WITH PERMISSION package. The Parameter Set is encoded as follows:

Table 63 LocationRequest INVOKE Parameters

LocationRequest INVOKE Parameters				Timer: LRT
Field	Value	Type	Reference	Notes
Identifier	SET [NATIONAL 18]	M	6.3.2.1	
Length	variable octets	M	6.3.2.1	
Contents				
BillingID (Originating)		M	6.5.2.16	
Digits (Dialed)		M	6.5.2.58	
MSCID (Originating)		M	6.5.2.82	
SystemMyTypeCode (Originating)		M	6.5.2.147	
CallingPartyNumberDigits1		O	6.5.2.21	a
CallingPartyNumberDigits2		O	6.5.2.22	a
CallingPartySubaddress		O	6.5.2.25	a
MSCIdentificationNumber		O	6.5.2.83	b
PC_SSN (Originating)		O	6.5.2.93	c
RedirectingNumberDigits		O	6.5.2.107	a
RedirectingSubaddress		O	6.5.2.109	a
TerminationAccessType		O	6.5.2.155	d
TransactionCapability		O	6.5.2.160	e

Notes:

- a. Include if available (i.e., provided in call origination).
- b. Include to identify the MSC sending the message.
- c. Include if SS7 may be used for subsequent call redirection.
- d. Include if call involves a special access situation (e.g., *Roamer port access*).
- e. Include on *IS-41-C* or later.

The LocationRequest operation success is reported with a TCAP RETURN RESULT (LAST). This is carried by a TCAP RESPONSE package. The Parameter Set is encoded as follows:

Table 64 LocationRequest RETURN RESULT Parameters

LocationRequest RETURN RESULT Parameters				
Field	Value	Type	Reference	Notes
Identifier	SET [NATIONAL 18]	M	6.3.2.2	
Length	variable octets	M	6.3.2.2	
Contents				
ElectronicSerialNumber		M	6.5.2.63	a
MobileIdentificationNumber		M	6.5.2.81	a
MSCID (Serving MSC)		M	6.5.2.82	b
AccessDeniedReason		O	6.5.2.1	c
AnnouncementList		O	6.5.2.6	d
ChargingAreaInformation		O	6.5.2.J1	J1 *
CallingPartyNumberString1		O	6.5.2.23	e
CallingPartyNumberString2		O	6.5.2.24	e
CarrierIdentificationCode		O	6.5.2.J2	J1 *
Digits (Carrier)		O	6.5.2.58	f
Digits (Destination)		O	6.5.2.58	g, h
DMH_AccountCodeDigits		O	6.5.2.59	i
DMH_AlternateBillingDigits		O	6.5.2.60	i
DMH_BillingDigits		O	6.5.2.61	i
DMH_RedirectionIndicator		O	6.5.2.62	j
GroupInformation		O	6.5.2.69	k
MobileAdditionalParty'sCategory3		O	6.5.2.J3	J1 *
MobileDirectoryNumber		O	6.5.2.80	i
NoAnswerTime		O	6.5.2.87	l
OneTimeFeatureIndicator		O	6.5.2.88	m
PC_SSN (Serving MSC or VLR)		O	6.5.2.93	n
RedirectingNumberDigits		O	6.5.2.107	j
RedirectingNumberString		O	6.5.2.108	f
RedirectingSubaddress		O	6.5.2.109	e, j
RoutingDigits		O	6.5.2.114	f
TerminationList		O	6.5.2.156	o
TerminationTrigger		O	6.5.2.159	f

Notes:

- a. Value is all zeroes, if unknown.
- b. Value is MSCID (Originating), if access is denied or routing to a directory number.
- c. Include if access may be denied.
- d. Include if one or more tones or announcements is to be applied to the MS.

- 1
2
3
4
5
6
7
8
9
10
11
12
13
14
15
16
17
18
19
20
21
22
23
24
25
26
27
28
29
- e. Include if feature is active and if a LocalTermination parameter is included within the TerminationList parameter.
 - f. Include if applicable.
 - g. Include if call is to be routed over a network.
 - h. Use only with system not capable of using the TerminationList parameter.
 - i. Include if available for recording purposes (see *DMH*).
 - j. Include if available and call redirection may apply.
 - k. Include for multileg calls.
 - l. Include to request an override of the Originating MSC's default *No Answer Time* value.
 - m. Include if modification to normal feature processing is required for a call in progress.
 - n. Use is for further study.
 - o. Include if call routing is required.
- J1. Include for Interconnection charge billing system. *

30 6.4.2.28 MobileOnChannel

31
32
33
34
35
36

The MobileOnChannel operation is invoked from the Target MSC to confirm the arrival of the MS on the new channel, and thus a successful handoff. The MobileOnChannel completes a transaction started with a FacilitiesDirective or a FacilitiesDirective2 operation invocation.

37
38
39

The MobileOnChannel operation is initiated with a TCAP INVOKE (LAST). This is carried by a TCAP RESPONSE package. The Parameter Set is encoded as follows:

40
41

Table 65 MobileOnChannel INVOKE Parameters

MobileOnChannel INVOKE Parameters				Timer: none
Field	Value	Type	Reference	Notes
Identifier	SET [NATIONAL 18]	M	6.3.2.1	
Length	zero octets	M	6.3.2.1	
Contents				

42
43
44
45
46
47
48
49
50
51
52
53
54
55
56
57
58
59
60

Note that a RETURN RESULT or a RETURN ERROR component is never expected in reply to the MobileOnChannel INVOKE message.

6.4.2.29 MSInactive

This operation was named CSSInactive prior to this revision of the Interim Standard.

The MSInactive operation is used to indicate that an MS is inactive. The MSInactive operation is also used by the Serving VLR to notify the HLR of the cancellation of an MS's registration. The MSInactive operation is used by the HLR to provide the MS's CallHistoryCount to the AC when the SSD is shared with the VLR, and the VLR cancels the MS's registration.

The MSInactive operation is initiated with a TCAP INVOKE (LAST). This is carried by a TCAP QUERY WITH PERMISSION package. The Parameter Set is encoded as follows:

Table 66 MSInactive INVOKE Parameters

MSInactive INVOKE Parameters				Timer: MSIT
Field	Value	Type	Reference	Notes
Identifier	SET [NATIONAL 18]	M	6.3.2.1	
Length	variable octets	M	6.3.2.1	
Contents				
ElectronicSerialNumber		M	6.5.2.63	
MobileIdentificationNumber		M	6.5.2.81	
ChargingAreaInformation		O	6.5.2.J1	J1 *
CallHistoryCount		O	6.5.2.18	a
CarrierIdentificationCode		O	6.5.2.J2	J1 *
DeregistrationType		O	6.5.2.55	b
LocationAreaID		O	6.5.2.77	c
SenderIdentificationNumber		O	6.5.2.116	d
SMS_MessageWaitingIndicator		O	6.5.2.129	e

Notes:

- a. Include if MS registration is canceled and if the SSD is shared.
- b. Include from VLR to HLR and HLR to AC for MS deregistration.
- c. May be included from MSC-V to VLR. Usage in the HLR is not defined.
- d. Include to identify the functional entity sending this message.
- e. Include to indicate that an SMS message is pending delivery.
- J1. Include for Interconnection charge billing system. *

The MSInactive operation success is reported with a TCAP RETURN RESULT (LAST). This is carried by a TCAP RESPONSE package. The Parameter Set is encoded as follows:

Table 67 MSInactive RETURN RESULT Parameters

MSInactive RETURN RESULT Parameters				
Field	Value	Type	Reference	Notes
Identifier	SET [NATIONAL 18]	M	6.3.2.2	
Length	zero octets	M	6.3.2.2	
Contents				

1
2
3
4
5
6
7
8
9
10
11
12
13
14
15
16
17
18
19
20
21
22
23
24
25
26
27
28
29
30
31
32
33
34
35
36
37
38
39
40
41
42
43
44
45
46
47
48
49
50
51
52
53
54
55
56
57
58
59
60

6.4.2.30 OriginationRequest

The OriginationRequest operation is used to request call origination treatment on behalf of a registered MS.

The OriginationRequest operation is initiated with a TCAP INVOKE (LAST). This is carried by a TCAP QUERY WITH PERMISSION package. The Parameter Set is encoded as follows:

Table 68 OriginationRequest INVOKE Parameters

OriginationRequest INVOKE Parameters				Timer: ORT
Field	Value	Type	Reference	Notes
Identifier	SET [NATIONAL 18]	M	6.3.2.1	
Length	Variable octets	M	6.3.2.1	
Contents				
BillingID (originating)		M	6.5.2.16	
Digits (Dialed)		M	6.5.2.58	
ElectronicSerialNumber		M	6.5.2.63	
MobileIdentificationNumber		M	6.5.2.81	
MSCID (Originating MSC)		M	6.5.2.82	
OriginationTriggers		M	6.5.2.90	
TransactionCapability		M	6.5.2.160	
ChargingAreaInformation		O	6.5.2.J1	J1 *
CallingPartyNumberDigits1		O	6.5.2.21	a
CallingPartyNumberDigits2		O	6.5.2.22	a
CallingPartySubaddress		O	6.5.2.25	a
CarrierIdentificationCode		O	6.5.2.J2	J1 *
MobileDirectoryNumber		O	6.5.2.80	b
MSCIdentificationNumber		O	6.5.2.83	c
OneTimeFeatureIndicator		O	6.5.2.88	d
PC_SSN (Originating MSC)		O	6.5.2.93	e
SenderIdentificationNumber		O	6.5.2.116	f

Notes:

- a. Include if applicable.
- b. Include if available for recording purposes (see *DMH*).
- c. Include to identify the MSC initiating the message.
- d. Include if any OneTimeFeatureIndicator status bits are set (i.e., have value of *I*).
- e. Include if SS7 may be used for subsequent call redirection.
- f. Include to identify intermediate message sender if different from the MSCIdentificationNumber.
- J1. Include for Interconnection charge billing system. *

The OriginationRequest operation success is reported with a TCAP RETURN RESULT (LAST). This is carried by a TCAP RESPONSE package. The Parameter Set is encoded as follows:

Table 69 OriginationRequest RETURN RESULT Parameters

OriginationRequest RETURN RESULT Parameters				
Field	Value	Type	Reference	Notes
Identifier	SET [NATIONAL 18]	M	6.3.2.2	
Length	Variable octets	M	6.3.2.2	
Contents				
AccessDeniedReason		O	6.5.2.1	a
ActionCode		O	6.5.2.2	b
AnnouncementList		O	6.5.2.6	c
CallingPartyNumberString1		O	6.5.2.23	d, e
CallingPartyNumberString2		O	6.5.2.24	d, e
CallingPartySubaddress		O	6.5.2.25	d, e, f
CrrierDigits		O	6.5.2.28	g
Digits (Dialed)		O	6.5.2.58	h
DMH_AccountCodeDigits		O	6.5.2.59	i
DMH_AlternateBillingDigits		O	6.5.2.60	i
DMH_BillingDigits		O	6.5.2.61	i
DMH_RedirectionIndicator		O	6.5.2.62	i, j
GroupInformation		O	6.5.2.69	k
MobileDirectoryNumber		O	6.5.2.80	i
NoAnswerTime		O	6.5.2.87	l
OneTimeFeatureIndicator		O	6.5.2.88	m
PilotNumber		O	6.5.2.95	k
RedirectingNumberDigits		O	6.5.2.107	f
RedirectingNumberString		O	6.5.2.108	d
RedirectingSubaddress		O	6.5.2.109	d, e
RoutingDigits		O	6.5.2.114	g
TerminationList		O	6.5.2.156	n
TerminationTrigger		O	6.5.2.57	o

Notes:

- a. Include if access is denied. If included, no other optional parameters shall be included (with the exception of the AnnouncementList parameter).
- b. Include if action to be performed is not implied through presence of other parameters.
- c. Include if one or more tones or announcements are to be applied to the MS.
- d. Include if a LocalTermination parameter is included in the TerminationList parameter.
- e. Include if the related feature is active.

- f. Include if a `PSTNTermination` parameter or an `IntersystemTermination` parameter is included within the `TerminationList` parameter.
- g. Include if applicable.
- h. Include if digits remain to be translated by the MSC.
- i. Include if available for recording purposes (see *DMH*).
- j. Include if redirection may apply.
- k. Include for multileg calls.
- l. Include to request an override of the Serving MSC's default *No Answer Time* value.
- m. Include if modification to normal feature processing is required for the call in progress.
- n. Include if call routing is required.
- o. Include to indicate processing in the Originating MSC for failed call attempts.

6.4.2.31 QualificationDirective

The QualificationDirective operation is used to update the authorization information, profile information, or both, previously obtained for an MS.

The QualificationDirective operation is initiated with a TCAP INVOKE (LAST). This is carried by a TCAP QUERY WITH PERMISSION package. The Parameter Set is encoded as follows:

Table 70 QualificationDirective INVOKE Parameters

QualificationDirective INVOKE Parameters				Timer: QDT
Field	Value	Type	Reference	Notes
Identifier	SET [NATIONAL 18]	M	6.3.2.1	
Length	variable octets	M	6.3.2.1	
Contents				
	ElectronicSerialNumber	M	6.5.2.63	
	MobileIdentificationNumber	M	6.5.2.81	
	QualificationInformationCode	M	6.5.2.99	
	SystemMyTypeCode (HLR or VLR)	M	6.5.2.147	
	AuthorizationDenied	O	6.5.2.13	a
	AuthorizationPeriod	O	6.5.2.14	b
	DeniedAuthorizationPeriod	O	6.5.2.53	c
	Digits (Carrier)	O	6.5.2.58	d, e
	Digits (Destination)	O	6.5.2.58	d, f
	LocationAreaID	O	6.5.2.77	g
	Profile **Macro**	O	6.5.2.97	h, J1
	SenderIdIdentificationNumber	O	6.5.2.116	i

Notes:

- a. If included, no other optional parameters except the DeniedAuthorizationPeriod parameter shall be present.
- b. Include if validation is being updated.
- c. May be included if the AuthorizationDenied parameter is present to indicate the interval before re-authorization may be attempted.
- d. Use only on systems not capable of supporting the TransactionCapability parameter.
- e. Include if profile is being updated and preferred carrier is applicable.
- f. Include if profile is being updated and originations are restricted to NDC-X1 ~ Xn.
- g. May be included from VLR to MSC-V. Usage from the HLR is not defined.
- h. Include applicable parameter(s) (see 6.5.2.97).
- i. Include to identify the functional entity sending the message.
- J1. The following parameter is included in Profile parameter for Interconnection charge billing system.

*

*

*

MobileAdditionalParty'sCategory3

*

The QualificationDirective operation success is reported with a TCAP RETURN RESULT (LAST). This is carried by a TCAP RESPONSE package. The Parameter Set is encoded as follows:

Table 71 QualificationDirective RETURN RESULT Parameters

QualificationDirective RETURN RESULT Parameters				
Field	Value	Type	Reference	Notes
Identifier	SET [NATIONAL 18]	M	6.3.2.2	
Length	Zero octets	M	6.3.2.2	
Contents				

6.4.2.32 QualificationRequest

The QualificationRequest operation is used (a) to request validation of an MS, (b) to request an MS's profile information, or (c) both.

The QualificationRequest operation is initiated with a TCAP INVOKE (LAST). This is carried by a TCAP QUERY WITH PERMISSION package. The Parameter Set is encoded as follows:

Table 72 QualificationRequest INVOKE Parameters

QualificationRequest INVOKE Parameters				Timer: QRT
Field	Value	Type	Reference	Notes
Identifier	SET [NATIONAL 18]	M	6.3.2.1	
Length	variable octets	M	6.3.2.1	
Contents				
ElectronicSerialNumber		M	6.5.2.63	
MobileIdentificationNumber		M	6.5.2.81	
QualificationInformationCode		M	6.5.2.99	
SystemMyTypeCode (MSC or VLR)		M	6.5.2.147	
MSCID (Serving MSC or Originating MSC)		O	6.5.2.82	a
SenderIdIdentificationNumber		O	6.5.2.116	b
SystemAccessType		O	6.5.2.145	a
TransactionCapability		O	6.5.2.160	a

Notes:

- a. Should be included on *IS-41-C* or later.
- b. Include to identify the functional entity sending the message.

The QualificationRequest operation success is reported with a TCAP RETURN RESULT (LAST). This is carried by a TCAP RESPONSE package. The Parameter Set is encoded as follows:

Table 73 QualificationRequest RETURN RESULT Parameters

QualificationRequest RETURN RESULT Parameters				
Field	Value	Type	Reference	Notes
Identifier	SET [NATIONAL 18]	M	6.3.2.2	
Length	variable octets	M	6.3.2.2	
Contents				
	SystemMyTypeCode (VLR or HLR)	M	6.5.2.147	
	AuthorizationDenied	O	6.5.2.13	a
	AuthorizationPeriod	O	6.5.2.14	b
	DeniedAuthorizationPeriod	O	6.5.2.53	c
	Digits (Carrier)	O	6.5.2.58	d
	Digits (Destination)	O	6.5.2.58	e
	MSCID (HLR)	O	6.5.2.82	f
	Profile **Macro**	O	6.5.2.97	g, J1

*

Notes:

- a. If included, no other optional parameters except the DeniedAuthorizationPeriod parameter shall be present.
 - b. Include if validation requested.
 - c. May be included if the AuthorizationDenied parameter is present to indicate the interval before re-authorization may be attempted.
 - d. Include if profile requested and preferred carrier is applicable and TransactionCapability parameter is not received.
 - e. Include if profile requested and originations are restricted to NDC-X1 ~ Xn and TransactionCapability parameter is not received.
 - f. Include on *IS-41-C* and later and authorization is not denied.
 - g. Include applicable parameter(s) (see 6.5.2.97).
- J1. The following parameters are included in Profile parameter for Interconnection charge billing system.
- ChargingAreaInformation
 - CarrierIdentificationCode
 - MobileAdditionalParty'sCategory3

*
*
*
*
*

6.4.2.33 RandomVariableRequest

The RandomVariableRequest operation is used by the Serving MSC to request the value of RAND from a Border MSC corresponding to the RANDC received from an MS. This operation may be used if the value of RANDC received from an MS corresponds to a RAND value that may be transmitted by a Border MSC which is transmitting the same SID as the Serving MSC.

The RandomVariableRequest operation is initiated with a TCAP INVOKE (LAST). This is carried by a TCAP QUERY WITH PERMISSION package. The Parameter Set is encoded as follows:

Table 74 RandomVariableRequest INVOKE Parameters

RandomVariableRequest INVOKE Parameters				Timer: RANDRT
Field	Value	Type	Reference	Notes
Identifier	SET [NATIONAL 18]	M	6.3.2.1	
Length	variable octets	M	6.3.2.1	
Contents				
	MSCID (Serving MSC)	M	6.5.2.82	
	RANDC	M	6.5.2.100	
	ServingCellID	M	6.5.2.117	

The RandomVariableRequest operation success is reported with a TCAP RETURN RESULT (LAST). This is carried by a TCAP RESPONSE package. The Parameter Set is encoded as follows:

Table 75 RandomVariableRequest RETURN RESULT Parameters

RandomVariableRequest RETURN RESULT Parameters				
Field	Value	Type	Reference	Notes
Identifier	SET [NATIONAL 18]	M	6.3.2.2	
Length	variable octets	M	6.3.2.2	
Contents				
	RandomVariable	O	6.5.2.101	a
	RANDValidTime	O	6.5.2.105	a

Notes:

- a Include only when the RANDC received in the INVOKE can be associated with a currently or recently transmitted RAND.

6.4.2.34 RedirectionDirective

The RedirectionDirective operation is used during feature processing to direct the MSC to forward the indicated call.

The RedirectionDirective operation is initiated with a TCAP INVOKE (LAST). This is carried by a TCAP QUERY WITH PERMISSION package. The Parameter Set is encoded as follows:

Table 76 RedirectionDirective INVOKE Parameters

RedirectionDirective INVOKE Parameters				Timer: RDT
Field	Value	Type	Reference	Notes
Identifier	SET [NATIONAL 18]	M	6.3.2.1	
Length	variable octets	M	6.3.2.1	
Contents				
BillingID (Originating)		M	6.5.2.16	
Digits (Destination)		M	6.5.2.58	
ElectronicSerialNumber		M	6.5.2.63	
MobileIdentificationNumber		M	6.5.2.81	
SystemMyTypeCode (MSC)		M	6.5.2.147	
Digits (Carrier)		O	6.5.2.58	a
DMH_AccountCodeDigits		O	6.5.2.59	b
DMH_AlternateBillingDigits		O	6.5.2.60	b
DMH_BillingDigits		O	6.5.2.61	b
MSCIdentificationNumber		O	6.5.2.83	c
RedirectingNumberString		O	6.5.2.108	d
RedirectingSubaddress		O	6.5.2.109	d
SenderIdentificationNumber		O	6.5.2.116	e

Notes:

- a. Include if applicable.
- b. Include if available for recording purposes (see *DMH*).
- c. Include to identify the initiating MSC.
- d. Optionally, include to override normal Originating MSC redirection number treatment.
- e. Include if the sending functional entity's identification number is not equal to the initiating MSC's identification number.

The RedirectionDirective operation success is reported with a TCAP RETURN RESULT (LAST). This is carried by a TCAP RESPONSE package. The Parameter Set is encoded as follows:

Table 77 RedirectionDirective RETURN RESULT Parameters

RedirectionDirective RETURN RESULT Parameters				
Field	Value	Type	Reference	Notes
Identifier	SET [NATIONAL 18]	M	6.3.2.2	
Length	Zero octets	M	6.3.2.2	
Contents				

1
2
3
4
5
6
7
8
9
10
11
12
13
14
15
16
17
18
19
20
21
22
23
24
25
26
27
28
29
30
31
32
33
34
35
36
37
38
39
40
41
42
43
44
45
46
47
48
49
50
51
52
53
54
55
56
57
58
59
60

6.4.2.35 RedirectionRequest

The RedirectionRequest operation is used by the Serving MSC to request redirection of a call by the Originating MSC.

The RedirectionRequest operation is initiated with a TCAP INVOKE (LAST). This is carried by a TCAP QUERY WITH PERMISSION package. The Parameter Set is encoded as follows:

Table 78 RedirectionRequest INVOKE Parameters

RedirectionRequest INVOKE Parameters				Timer: RDRT
Field	Value	Type	Reference	Notes
Identifier	SET [NATIONAL 18]	M	6.3.2.1	
Length	variable octets	M	6.3.2.1	
Contents				
BillingID (Originating)		M	6.5.2.16	
ElectronicSerialNumber		M	6.5.2.63	
MobileIdentificationNumber		M	6.5.2.81	
RedirectionReason		M	6.5.2.110	
ChargingAreaInformation		O	6.5.2.J1	J1 *
CarrierIdentificationCode		O	6.5.2.J2	J1 *
LegInformation		O	6.5.2.75	a
MSCIdentificationNumber		O	6.5.2.83	b

Notes:

- a. Include if available (i.e., if provided in the associated RoutingRequest INVOKE component).
- b. Include to identify Serving MSC.
- J1. Include for Interconnection charge billing system. *

The RedirectionRequest operation success is reported with a TCAP RETURN RESULT (LAST). This is carried by a TCAP RESPONSE package. The Parameter Set is encoded as follows:

Table 79 RedirectionRequest RETURN RESULT Parameters

RedirectionRequest RETURN RESULT Parameters				
Field	Value	Type	Reference	Notes
Identifier	SET [NATIONAL 18]	M	6.3.2.2	
Length	Zero octets	M	6.3.2.2	
Contents				

6.4.2.36 RegistrationCancellation

The RegistrationCancellation operation is used to report, to the responding FE, that a previously registered MS is no longer in its serving area. The VLR may possess additional information which allows it to determine that the RegistrationCancellation INVOKE is invalid, thereby causing the VLR to deny the cancellation.

The RegistrationCancellation operation is initiated with a TCAP INVOKE (LAST). This is carried by a TCAP QUERY WITH PERMISSION package. The Parameter Set is encoded as follows:

Table 80 RegistrationCancellation INVOKE Parameters

RegistrationCancellation INVOKE Parameters				Timer: RCT
Field	Value	Type	Reference	Notes
Identifier	SET [NATIONAL 18]	M	6.3.2.1	
Length	variable octets	M	6.3.2.1	
Contents				
	ElectronicSerialNumber	M	6.5.2.63	
	MobileIdentificationNumber	M	6.5.2.81	
	CancellationType	O	6.5.2.27	a
	ControlChannelData	O	6.5.2.51	b
	ReceivedSignalQuality	O	6.5.2.106	b
	SenderIdentificationNumber	O	6.5.2.116	c
	SystemAccessData	O	6.5.2.144	b

Notes:

- a. Include if applicable.
- b. Include if registration cancellation is the result of multiple access arbitration.
- c. Include to identify the functional entity sending the message.

The RegistrationCancellation operation success is reported with a TCAP RETURN RESULT (LAST). This is carried by a TCAP RESPONSE package. The Parameter Set is encoded as follows:

Table 81 RegistrationCancellation RETURN RESULT Parameters

RegistrationCancellation RETURN RESULT Parameters				
Field	Value	Type	Reference	Notes
Identifier	SET [NATIONAL 18]	M	6.3.2.2	
Length	variable octets	M	6.3.2.2	
Contents				
CallHistoryCount		O	6.5.2.18	a
CancellationDenied		O	6.5.2.26	b
ControlChannelData		O	6.5.2.51	b
ReceivedSignalQuality		O	6.5.2.106	b
SMS_MessageWaitingIndicator		O	6.5.2.129	c
SystemAccessData		O	6.5.2.144	b

Notes:

- a. Include if SSD is shared.
- b. Include if registration cancellation is denied.
- c. Include to indicate that an SMS message is pending delivery.

6.4.2.37 RegistrationNotification

The RegistrationNotification operation is used to report the location of an MS and, optionally, to (a) validate the MS or (b) validate the MS and obtain its profile information.

The RegistrationNotification operation is initiated with a TCAP INVOKE (LAST). This is carried by a TCAP QUERY WITH PERMISSION package. The Parameter Set is encoded as follows:

Table 82 RegistrationNotification INVOKE Parameters

RegistrationNotification INVOKE Parameters				Timer: RNT
Field	Value	Type	Reference	Notes
Identifier	SET [NATIONAL 18]	M	6.3.2.1	
Length	variable octets	M	6.3.2.1	
Contents				
ElectronicSerialNumber		M	6.5.2.63	
MobileIdentificationNumber		M	6.5.2.81	
MSCID (Serving MSC)		M	6.5.2.82	
QualificationInformationCode		M	6.5.2.99	
SystemMyTypeCode (Serving MSC or VLR)		M	6.5.2.147	
AvailabilityType		O	6.5.2.15	a
BorderCellAccess		O	6.5.2.17	b
ChargingAreaInformation		O	6.5.2.J1	J1
CarrierIdentificationCode		O	6.5.2.J2	J1
ControlChannelData		O	6.5.2.51	b
ExtendedMSCID (VLR)		O	6.5.2.64	c
LocationAreaID		O	6.5.2.77	d
PC_SSN (Serving MSC or VLR)		O	6.5.2.93	e
ReceivedSignalQuality		O	6.5.2.106	b
ReportType		O	6.5.2.112	f
SenderIdentificationNumber		O	6.5.2.116	g
SMS_Address		O	6.5.2.123	h
SMS_MessageWaitingIndicator		O	6.5.2.129	i
SystemAccessData		O	6.5.2.144	b
SystemAccessType		O	6.5.2.145	j
SystemCapabilities		O	6.5.2.146	k
TerminalType		O	6.5.2.154	j
TransactionCapability		O	6.5.2.160	j

Notes:

- a. Include when MS is predictably unavailable for Call Delivery (e.g., slotted mode or sleep mode).
- b. Include if access occurred in a border cell (based on internal algorithms).
- c. Included by VLR if its MSCID is different than the MSC's MSCID.

- d. May be included from MSC to VLR.
- e. Include to override lower layer addressing.
- f. Include if authentication parameters were requested by the Serving MSC (AUTH=1 in the Overhead Message Train) but were not received from the MS for the system access.
- g. Include to identify message sender.
- h. Include to indicate that the Serving MSC supports Short Message Service.
- i. Include if the MS was previously registered with this VLR, the MS is registering to a new serving MSC that does not support SMS, and an SMS message is pending delivery in the previous serving system. This is only used between a VLR and an HLR.
- j. Include on *IS-41-C* and later.
- k. Include if the system is authentication capable (including voice channel authentication only systems where all flags are zero).
- J1. Include for Interconnection charge billing system. *

The RegistrationNotification operation success is reported with a TCAP RETURN RESULT (LAST). This is carried by a TCAP RESPONSE package. The Parameter Set is encoded as follows:

Table 83 RegistrationNotification RETURN RESULT Parameters

RegistrationNotification RETURN RESULT Parameters				
Field	Value	Type	Reference	Notes
Identifier	SET [NATIONAL 18]	M	6.3.2.2	
Length	variable octets	M	6.3.2.2	
Contents				
SystemMyTypeCode (VLR or HLR)		M	6.5.2.147	
AuthorizationDenied		O	6.5.2.13	a
AuthorizationPeriod		O	6.5.2.14	b
ControlChannelData		O	6.5.2.51	c
DeniedAuthorizationPeriod		O	6.5.2.53	d
Digits (Carrier)		O	6.5.2.58	e
Digits (Destination)		O	6.5.2.58	f
MSCID (HLR)		O	6.5.2.82	g
Profile **Macro**		O	6.5.2.97	h, J1
ReceivedSignalQuality		O	6.5.2.106	c
SenderIdentificationNumber		O	6.5.2.116	i
SMS_MessageWaitingIndicator		O	6.5.2.129	j
SystemAccessData		O	6.5.2.144	c

Notes:

- a. If included, only the ControlChannelData, DeniedAuthorizationPeriod, ReceivedSignalQuality, and SystemAccessData optional parameters have significance.
- b. Include if validation requested.
- c. Include if AuthorizationDenied parameter is included with value of *Multiple Access*.
- d. May be included if the AuthorizationDenied parameter is present to indicate the interval before re-authorization may be attempted.
- e. Include if the profile is requested, the preferred carrier is applicable, and the CarrierDigits parameter is not included in the Profile macro .
- f. Include if the profile is requested, originations are restricted to NDC-X1 ~ Xn, and the RestrictionDigits parameter is not included in the Profile macro .
- g. Include on *IS-41-C* and later and authorization is not denied.
- h. Include applicable parameter(s) (see 6.5.2.97).
- i. Include to identify the functional entity sending the message.
- j. Include to indicate that an SMS message is pending delivery.
- J1. The following parameter is included in Profile parameter for Interconnction charge billing system.

*

*

*

6.4.2.38 RemoteUserInteractionDirective

The RemoteUserInteractionDirective operation is used by the HLR to remotely direct the operation of an MSC (or other functional entity) which provides user interaction; i.e., the RUI-MSC. The RUI-MSC may be an Originating MSC, a Serving MSC or some other functional entity capable of user interaction.

The RemoteUserInteractionDirective operation is initiated with a TCAP INVOKE (LAST). This is carried by a TCAP CONVERSATION WITHOUT PERMISSION package. The Parameter Set is encoded as follows:

Table 84 RemoteUserInteractionDirective INVOKE Parameters

RemoteUserInteractionDirective INVOKE Parameters				Timer: RUDT
Field	Value	Type	Reference	Notes
Identifier	SET [NATIONAL 18]	M	6.3.2.1	
Length	variable octets	M	6.3.2.1	
Contents				
	AnnouncementList	M	6.5.2.6	
	DigitCollectionControl	M	6.5.2.57	

The RemoteUserInteractionDirective operation success is reported with a TCAP RETURN RESULT (LAST). This is carried by a TCAP CONVERSATION WITH PERMISSION package. The Parameter Set is encoded as follows:

Table 85 RemoteUserInteractionDirective RETURN RESULT Parameters

RemoteUserInteractionDirective RETURN RESULT Parameters				
Field	Value	Type	Reference	Notes
Identifier	SET [NATIONAL 18]	M	6.3.2.2	
Length	variable octets	M	6.3.2.2	
Contents				
	Digits (Dialed)	O	6.5.2.58	a

Notes:

- a. Include if call has not been abandoned. The number of digits returned may be zero, implying that the user did not dial before time-out.

6.4.2.39 ResetCircuit

The ResetCircuit operation is used by an MSC to restore information about circuit conditions which has been lost due to, for example, a restart. It may also be used to when placing circuits into service.

The ResetCircuit operation is initiated with a TCAP INVOKE (LAST). This is carried by a TCAP QUERY WITH PERMISSION package. The Parameter Set is encoded as follows:

Table 86 ResetCircuit INVOKE Parameters

ResetCircuit INVOKE Parameters				Timer: RSTT
Field	Value	Type	Reference	Notes
Identifier	SET [NATIONAL 18]	M	6.3.2.1	
Length	variable octets	M	6.3.2.1	
Contents				
	InterMSCCircuitID	M	6.5.2.72	

The ResetCircuit operation success is reported with a TCAP RETURN RESULT (LAST). This is carried by a TCAP RESPONSE package. The Parameter Set is encoded as follows:

Table 87 ResetCircuit RETURN RESULT Parameters

ResetCircuit RETURN RESULT Parameters				
Field	Value	Type	Reference	Notes
Identifier	SET [NATIONAL 18]	M	6.3.2.2	
Length	variable octets	M	6.3.2.2	
Contents				
	TrunkStatus	M	6.5.2.161	

6.4.2.40 RoutingRequest

The RoutingRequest operation is used to inquire as to the preferred method of routing a pending call to the identified MS.

The RoutingRequest operation is initiated with a TCAP INVOKE (LAST). This is carried by a TCAP QUERY WITH PERMISSION package. The Parameter Set is encoded as follows:

Table 88 RoutingRequest INVOKE Parameters

RoutingRequest INVOKE Parameters				Timer: RRT
Field	Value	Type	Reference	Notes
Identifier	SET [NATIONAL 18]	M	6.3.2.1	
Length	variable octets	M	6.3.2.1	
Contents				
BillingID (Originating)		M	6.5.2.16	a
ElectronicSerialNumber		M	6.5.2.63	
MobileIdentificationNumber		M	6.5.2.81	
MSCID (Originating MSC)		M	6.5.2.82	
SystemMyTypeCode (Originating MSC)		M	6.5.2.147	
AlertCode		O	6.5.2.3	b
CallingPartyNumberString1		O	6.5.2.23	c
CallingPartyNumberString2		O	6.5.2.24	c
CallingPartySubaddress		O	6.5.2.25	c
DestinationDigits		O	6.5.2.56	d, e
DMH_AccountCodeDigits		O	6.5.2.59	f
DMH_AlternateBillingDigits		O	6.5.2.60	f
DMH_BillingDigits		O	6.5.2.61	f
LegInformation		O	6.5.2.75	g
LocalAreaID		O	6.5.2.77	f, h
MobileDirectoryNumber		O	6.5.2.80	f
MSCIdentificationNumber		O	6.5.2.83	i
NoAnswerTime		O	6.5.2.87	j
OneTimeFeatureIndicator		O	6.5.2.88	k
PC_SSN (Originating MSC)		O	6.5.2.93	l
PilotBillingID		O	6.5.2.94	m
PilotNumber		O	6.5.2.95	m
RedirectingNumberString		O	6.5.2.108	c
RedirectingSubaddress		O	6.5.2.109	c
SenderIdentificationNumber		O	6.5.2.116	n
TerminationTreatment		O	6.5.2.158	o
TerminationTriggers		O	6.5.2.159	f
VoiceMailboxNumber		O	6.5.2.164	p
VoiceMailboxPIN		O	6.5.2.165	q

Notes:

- a. Required to identify originating call.
- b. Include to specify special alerting treatment.
- c. Include if related feature is active.
- d. Optionally include if TerminationTreatment parameter value is *Dialogue*, to select a dialogue or to provide information to a dialogue.
- e. Optionally include if TerminationTreatment parameter value is *VoiceMailRetrieva* or *VoiceMailStorage* to select the voice mail system.
- f. Include if available and if TerminationTreatment parameter value is *MS termination*.
- g. Include if TerminationTreatment parameter value is *MS termination* and this is a multileg call (e.g., an FA call).
- h. May be included from VLR to MSC-V. Usage is not defined from HLR to VLR.
- i. Include to identify Originating MSC.
- j. Include to inform the serving system of the recommended no-answer time-out.
- k. Include if modification to normal feature processing is required for call in progress.
- l. Include if available (e.g., from received parameter or lower layers) for subsequent call redirection.
- m. Include on a multileg call.
- n. Include to identify the functional entity sending the message.
- o. Include to differentiate termination types, defaulting to value *MS termination*.
- p. Include if the TerminationTreatment parameter value is *VoiceMailRetrieval* or *VoiceMailStorage* and the mailbox is not the MobileIdentificationNumber.
- q. Optional, if the TerminationTreatment parameter value is *VoiceMailRetrieval* or *VoiceMailStorage*.

The RoutingRequest operation success is reported with a TCAP RETURN RESULT (LAST). This is carried by a TCAP RESPONSE package. The Parameter Set is encoded as follows:

Table 89 RoutingRequest RETURN RESULT Parameters

RoutingRequest RETURN RESULT Parameters				
Field	Value	Type	Reference	Notes
Identifier	SET [NATIONAL 18]	M	6.3.2.2	
Length	variable octets	M	6.3.2.2	
Contents				
MSCID (Serving)		M	6.5.2.82	
AccessDeniedReason		O	6.5.2.1	a
BillingID (Anchor)		O	6.5.2.16	b
ChargingAreaInformation		O	6.5.2.J1	J1
CarrierIdentificationCode		O	6.5.2.J2	J1
ConditionallyDeniedReason		O	6.5.2.48	c
Digits (Destination)		O	6.5.2.58	d
MSCIdentificationNumber		O	6.5.2.83	e
PC_SSN (Serving MSC)		O	6.5.2.93	f

Notes:

- a. Include if access may be denied.
- b. Include for recording purposes (see *DMH*).
- c. Include if Call Waiting is possible.
- d. Include for Temporary Local Directory Number (TLDN).
- e. Include to identify the Serving MSC.
- f. Use is for further study.
- J1. Include for Interconnection charge billing system.

*

*

*

6.4.2.41 SMSDeliveryBackward

The SMSDeliveryBackward operation is a general purpose operation that is used to convey an MS-originated short message or in general any other information or encapsulated data to the Anchor MSC after handoff.

The SMSDeliveryBackward operation is initiated with a TCAP INVOKE (LAST). This is carried by a TCAP QUERY WITH PERMISSION package. The Parameter Set is encoded as follows:

Table 90 SMSDeliveryBackward INVOKE Parameters

SMSDeliveryBackward INVOKE Parameters				Timer: SBT
Field	Value	Type	Reference	Notes
Identifier	SET [NATIONAL 18]	M	6.3.2.1	
Length	variable octets	M	6.3.2.1	
Contents				
	InterMSCCircuitID	M	6.5.2.72	
	MobileIdentificationNumber	M	6.5.2.81	a
	SMS_BearerData	M	6.5.2.124	
	SMS_TeleserviceIdentifier	M	6.5.2.137	
	ElectronicSerialNumber	O	6.5.2.63	b
	SMS_ChargeIndicator	O	6.5.2.126	c
	SMS_DestinationAddress	O	6.5.2.127	d
	SMS_OriginalDestinationAddress	O	6.5.2.131	e
	SMS_OriginalDestinationSubaddress	O	6.5.2.132	b
	SMS_OriginalOriginatingAddress	O	6.5.2.133	f
	SMS_OriginalOriginatingSubaddress	O	6.5.2.134	b
	SMS_OriginatingAddress	O	6.5.2.135	g

Notes:

- a. Include to identify the originating MS.
- b. Include if applicable.
- c. Include if applicable. If not received, charge message originator.
- d. Include if not carried by the underlying data transport. May require an interconnection agreement to facilitate interworking between network types.
- e. Include if different than the destination address (SMS_DestinationAddress or underlying data transport destination address).
- f. Include if different than the originating address (SMS_OriginatingAddress or underlying data transport originating address).
- g. Include if different than the MobileIdentificationNumber, or if not carried by the underlying data transport. May require an interconnection agreement to facilitate interworking between network types.

The SMSDeliveryBackward operation success is reported with a TCAP RETURN RESULT (LAST). This is carried by a TCAP RESPONSE package. The Parameter Set is encoded as follows:

Table 91 SMSDeliveryBackward RETURN RESULT Parameters

SMSDeliveryBackward RETURN RESULT Parameters				
Field	Value	Type	Reference	Notes
Identifier	SET [NATIONAL 18]	M	6.3.2.2	
Length	variable octets	M	6.3.2.2	
Contents				
SMS_BearerData		O	6.5.2.124	a
SMS_CauseCode		O	6.5.2.125	b

Notes:

- a. Include for positive acknowledgments, when applicable.
- b. Include for all negative acknowledgments.

6.4.2.42 SMSDeliveryForward

The SMSDeliveryForward operation is a general purpose operation that is used to convey an MS-terminated short message or in general any other information or encapsulated data to the Serving MSC after handoff.

The SMSDeliveryForward operation is initiated with a TCAP INVOKE (LAST). This is carried by a TCAP QUERY WITH PERMISSION package. The Parameter Set is encoded as follows:

Table 92 SMSDeliveryForward INVOKE Parameters

SMSDeliveryForward INVOKE Parameters				Timer: SFT
Field	Value	Type	Reference	Notes
Identifier	SET [NATIONAL 18]	M	6.3.2.1	
Length	variable octets	M	6.3.2.1	
Contents				
	InterMSCCircuitID	M	6.5.2.72	
	MobileIdentificationNumber	M	6.5.2.81	a
	SMS_BearerData	M	6.5.2.124	
	SMS_TelServiceIdentifier	M	6.5.2.137	
	ElectronicSerialNumber	O	6.5.2.63	b
	SMS_ChargeIndicator	O	6.5.2.126	c
	SMS_DestinationAddress	O	6.5.2.127	d
	SMS_OriginalDestinationAddress	O	6.5.2.131	e
	SMS_OriginalDestinationSubaddress	O	6.5.2.132	b
	SMS_OriginalOriginatingAddress	O	6.5.2.133	f
	SMS_OriginalOriginatingSubaddress	O	6.5.2.134	b
	SMS_OriginatingAddress	O	6.5.2.135	g

Notes:

- a. Include to identify the destination MS.
- b. Include if applicable.
- c. Include if applicable. If not received, charge message originator.
- d. Include if different than the destination address (MobileIdentificationNumber or underlying data transport destination address). May require an interconnection agreement to facilitate interworking between network types.
- e. Include if different than the destination address (MobileIdentificationNumber, SMS_DestinationAddress, or underlying data transport destination address).
- f. Include if different than the originating address (SMS_OriginatingAddress or underlying data transport originating address).
- g. Include if different than the MobileIdentificationNumber, or if not carried by the underlying data transport. May require an interconnection agreement to facilitate interworking between network types.

The SMSDeliveryForward operation success is reported with a TCAP RETURN RESULT (LAST). This is carried by a TCAP RESPONSE package. The Parameter Set is encoded as follows:

Table 93 SMSDeliveryForward RETURN RESULT Parameters

SMSDeliveryForward RETURN RESULT Parameters				
Field	Value	Type	Reference	Notes
Identifier	SET [NATIONAL 18]	M	6.3.2.2	
Length	variable octets	M	6.3.2.2	
Contents				
SMS_BearerData		O	6.5.2.124	a
SMS_CauseCode		O	6.5.2.125	b

Notes:

- a. Include for positive acknowledgments, when applicable.
- b. Include for all negative acknowledgments.

6.4.2.43 SMSDeliveryPointToPoint

The SMSDeliveryPointToPoint operation is a general purpose operation that is used to convey a short message or in general any other information or encapsulated data from one point to another point and report on the success of failure of that transfer.

The SMSDeliveryPointToPoint operation is initiated with a TCAP INVOKE (LAST). This is carried by a TCAP QUERY WITH PERMISSION package. The Parameter Set is encoded as follows:

Table 94 SMSDeliveryPointToPoint INVOKE Parameters

SMSDeliveryPointToPoint INVOKE Parameters				Timer: SMT
Field	Value	Type	Reference	Notes
Identifier	SET [NATIONAL 18]	M	6.3.2.1	
Length	variable octets	M	6.3.2.1	
Contents				
SMS_BearerData		M	6.5.2.124	
SMS_TeleserviceIdentifier		M	6.5.2.137	
ElectronicSerialNumber		O	6.5.2.63	a
MobileIdentificationNumber		O	6.5.2.81	a
SMS_ChargeIndicator		O	6.5.2.126	b
SMS_DestinationAddress		O	6.5.2.127	c
SMS_MessageCount		O	6.5.2.128	d
SMS_NotificationIndicator		O	6.5.2.130	e
SMS_OriginalDestinationAddress		O	6.5.2.131	f
SMS_OriginalDestinationSubaddress		O	6.5.2.132	g
SMS_OriginalOriginatingAddress		O	6.5.2.133	h
SMS_OriginalOriginatingSubaddress		O	6.5.2.134	g
SMS_OriginatingAddress		O	6.5.2.135	c

Notes:

- a. Include if known and the destination is an MS -based SME.
- b. Include if applicable. If not received, charge the message originator.
- c. May be included if not carried by the underlying data transport. May require an interconnection agreement to facilitate interworking between network types.
- d. Include if applicable. If not received, assume value 0.
- e. Include if no notification is necessary. If not received, assume notification is requested.
- f. Include if different than the destination address (SMS_DestinationAddress, MobileIdentificationNumber, or the underlying data transport destination).
- g. Include if applicable.
- h. Include if not the same as the originating address (SMS_OriginatingAddress or the underlying data transport originating address).

The SMSDeliveryPointToPoint operation success is reported with a TCAP RETURN RESULT (LAST). This is carried by a TCAP RESPONSE package. The Parameter Set is encoded as follows:

Table 95 SMSDeliveryPointToPoint RETURN RESULT Parameters

SMSDeliveryPointToPoint RETURN RESULT Parameters				
Field	Value	Type	Reference	Notes
Identifier	SET [NATIONAL 18]	M	6.3.2.2	
Length	variable octets	M	6.3.2.2	
Contents				
SMS_BearerData		O	6.5.2.124	a
SMS_CauseCode		O	6.5.2.125	b

Notes:

- a. Include for positive acknowledgments, when applicable.
- b. Include for all negative acknowledgments.

6.4.2.44 SMSNotification

The SMSNotification operation is used to report a change in an MS's ability to receive SMS messages based on the location or status of the MS. This message, at a minimum, is used to report the accessibility of an MS following a postponed SMSRequest or SMSDeliveryPointToPoint. This message may also be used to revoke delivery permission previously granted with either an SMSRequest or an SMSNotification.

The SMSNotification operation is initiated with a TCAP INVOKE (LAST). This is carried by a TCAP QUERY WITH PERMISSION package. The Parameter Set is encoded as follows:

Table 96 SMSNotification INVOKE Parameters

SMSNotification INVOKE Parameters				Timer: SNT
Field	Value	Type	Reference	Notes
Identifier	SET [NATIONAL 18]	M	6.3.2.1	
Length	variable octets	M	6.3.2.1	
Contents				
	ElectronicSerialNumber	M	6.5.2.63	
	MobileIdentificationNumber	M	6.5.2.81	
	SMS_AccessDeniedReason	O	6.5.2.122	a
	SMS_Address	O	6.5.2.123	a, b

Notes:

- a. These parameters are mutually exclusive; however, one must be present.
- b. Included to indicate the temporary routing address of an MS-based SME.

The SMSNotification operation success is reported with a TCAP RETURN RESULT (LAST). This is carried by a TCAP RESPONSE package. The Parameter Set is encoded as follows:

Table 97 SMSNotification RETURN RESULT Parameters

SMSNotification RETURN RESULT Parameters				
Field	Value	Type	Reference	Notes
Identifier	SET [NATIONAL 18]	M	6.3.2.2	
Length	zero octets	M	6.3.2.2	
Contents				

6.4.2.45 SMSRequest

The SMSRequest operation is used to request an MS's current SMS routing address with a default to request notification when the MS becomes available if the MS is not currently available.

The SMSRequest operation is initiated with a TCAP INVOKE (LAST). This is carried by a TCAP QUERY WITH PERMISSION package. The Parameter Set is encoded as follows:

Table 98 SMSRequest INVOKE Parameters

SMSRequest INVOKE Parameters				Timer: SRT
Field	Value	Type	Reference	Notes
Identifier	SET [NATIONAL 18]	M	6.3.2.1	
Length	variable octets	M	6.3.2.1	
Contents				
ElectronicSerialNumber		M	6.5.2.81	
MobileIdentificationNumber		O	6.5.2.63	a
SMS_NotificationIndicator		O	6.5.2.130	b
SMS_TeleserviceIdentifier		O	6.5.2.137	c

Notes:

- a. Include if known.
- b. Include to specify notification requirements. If not included, implies notification shall be sent when MS becomes available (default).
- c. Include if applicable.

The SMSRequest operation success is reported with a TCAP RETURN RESULT (LAST). This is carried by a TCAP RESPONSE package. The Parameter Set is encoded as follows:

Table 99 SMSRequest RETURN RESULT Parameters

SMSRequest RETURN RESULT Parameters				
Field	Value	Type	Reference	Notes
Identifier	SET [NATIONAL 18]	M	6.3.2.2	
Length	variable octets	M	6.3.2.2	
Contents				
ElectronicSerialNumber		O	6.5.2.63	a
SMS_AccessDeniedReason		O	6.5.2.122	b, c
SMS_Address		O	6.5.2.123	c, d

Notes:

- a. Include if not received in SMSRequest INVOKE and SMS delivery is allowed.
- b. Include if delivery of SMS messages is denied or deferred.
- c. These parameters are mutually exclusive.
- d. Include if routing of SMS messages is applicable.

6.4.2.46 TransferToNumberRequest

The TransferToNumberRequest operation is used during feature processing to obtain an MS's forward-to number from the HLR.

The TransferToNumberRequest operation is initiated with a TCAP INVOKE (LAST). This is carried by a TCAP QUERY WITH PERMISSION package. The Parameter Set is encoded as follows:

Table 100 TransferToNumberRequest INVOKE Parameters

TransferToNumberRequest INVOKE Parameters				Timer: TTNRT
Field	Value	Type	Reference	Notes
Identifier	SET [NATIONAL 18]	M	6.3.2.1	
Length	variable octets	M	6.3.2.1	
Contents				
	ElectronicSerialNumber	M	6.5.2.63	
	MobileIdentificationNumber	M	6.5.2.81	
	RedirectionReason	M	6.5.2.110	
	SystemMyTypeCode (MSC)	M	6.5.2.147	
	BillingID (Originating)	O	6.5.2.16	a
	GroupInformation	O	6.5.2.69	b
	LegInformation	O	6.5.2.75	c
	MSCID (Originating)	O	6.5.2.82	d
	MSCIdentificationNumber	O	6.5.2.83	e
	PilotBillingID	O	6.5.2.94	f
	PilotNumber	O	6.5.2.95	f
	TransactionCapability	O	6.5.2.160	e

Notes:

- a. Include to identify the Originating MSC and its BillingID for subsequent call redirection.
- b. Include if available (i.e., if provided in the associated RoutingRequest INVOKE or LocationRequest RETURN RESULT) for the termination trigger.
- c. Include if available (i.e., if provided in the associated RoutingRequest INVOKE or LocationRequest RETURN RESULT) for any termination trigger except .
- d. Include on *TIA/EIA-41* or later.
- e. Include on *IS-41-C* or later.
- f. Include if available.

The TransferToNumberRequest operation success is reported with a TCAP RETURN RESULT (LAST). This is carried by a TCAP RESPONSE package. The Parameter Set is encoded as follows:

Table 101 TransferToNumberRequest RETURN RESULT Parameters

TransferToNumberRequest RETURN RESULT Parameters				
Field	Value	Type	Reference	Notes
Identifier	SET [NATIONAL 18]	M	6.3.2.2	
Length	Variable octets	M	6.3.2.2	
Contents				
Digits (Destination)		M	6.5.2.58	a
AccessDeniedReason		O	6.5.2.1	b
ActionCode		O	6.5.2.2	c
AnnouncementList		O	6.5.2.6	d
CallingPartyNumberString1		O	6.5.2.23	e
CallingPartyNumberString2		O	6.5.2.24	e
CallingPartySubaddress		O	6.5.2.25	e, f
Digits (Carrier)		O	6.5.2.58	g
DMH_AccountCodeDigits		O	6.5.2.59	h
DMH_AlternateBillingDigits		O	6.5.2.60	h
DMH_BillingDigits		O	6.5.2.61	h
DMH_RedirectionIndicator		O	6.5.2.62	h
GroupInformation		O	6.5.2.69	i
MobileDirectoryNumber		O	6.5.2.80	h
NoAnswerTime		O	6.5.2.87	g
RedirectingNumberDigits		O	6.5.2.107	f
RedirectingNumberString		O	6.5.2.108	e
RedirectingSubaddress		O	6.5.2.109	e, f
TerminationList		O	6.5.2.156	j
TerminationTriggers		O	6.5.2.159	g

Notes:

- a. This parameter is ignored if the TerminationList parameter is provided.
- b. Include if access is denied. If included, no other optional parameters shall be included (with the exception of the AnnouncementList).
- c. Include if action to be performed is not implied through presence of other parameters.
- d. Include if one or more tones or announcements are to be applied to the MS.
- e. Include if related feature is active and if a LocalTermination parameter is included within the TerminationList parameter.
- f. Optionally include if a PSTNTermination parameter or an IntersystemTermination parameter is included within the TerminationList parameter.
- g. Include if applicable.

1
2
3
4
5
6
7
8
9
10
11
12
13
14
15
16
17
18
19
20
21
22
23
24
25
26
27
28
29
30
31
32
33
34
35
36
37
38
39
40
41
42
43
44
45
46
47
48
49
50
51
52
53
54
55
56
57
58
59
60

- h. Include if available for recording purposes (see *DMH*).
- i. Include for multileg calls.
- j. Include if call routing is required.

6.4.2.47 TrunkTest

The TrunkTest operation is used by an MSC to request that the designated trunk be placed in a test configuration (e.g., loop-back) at a remote MSC.

The TrunkTest operation is initiated with a TCAP INVOKE (LAST). This is carried by a TCAP QUERY WITH PERMISSION package. The Parameter Set is encoded as follows:

Table 102 TrunkTest INVOKE Parameters

TrunkTest INVOKE Parameters				Timer: TTT
Field	Value	Type	Reference	Notes
Identifier	SET [NATIONAL 18]	M	6.3.2.1	
Length	variable octets	M	6.3.2.1	
Contents				
InterMSCCircuitID		M	6.5.2.72	
SeizureType		M	6.5.2.115	

The TrunkTest operation success is reported with a TCAP RETURN RESULT (LAST). This is carried by a TCAP RESPONSE package. The Parameter Set is encoded as follows:

Table 103 TrunkTest RETURN RESULT Parameters

TrunkTest RETURN RESULT Parameters				
Field	Value	Type	Reference	Notes
Identifier	SET [NATIONAL 18]	M	6.3.2.2	
Length	zero octets	M	6.3.2.2	
Contents				

6.4.2.48 TrunkTestDisconnect

The TrunkTestDisconnect operation is used by an MSC to request that the designated trunk at a remote MSC be disconnected from its test configuration (e.g., loop-back).

The TrunkTestDisconnect operation is initiated with a TCAP INVOKE (LAST). This is carried by a TCAP QUERY WITH PERMISSION package. The Parameter Set is encoded as follows:

Table 104 TrunkTestDisconnect INVOKE Parameters

TrunkTestDisconnect INVOKE Parameters				Timer: TTDT
Field	Value	Type	Reference	Notes
Identifier	SET [NATIONAL 18]	M	6.3.2.1	
Length	variable octets	M	6.3.2.1	
Contents				
	InterMSCCircuitID	M	6.5.2.72	

The TrunkTestDisconnect operation success is reported with a TCAP RETURN RESULT (LAST). This is carried by a TCAP RESPONSE package. The Parameter Set is encoded as follows:

Table 105 TrunkTestDisconnect RETURN RESULT Parameters

TrunkTestDisconnect RETURN RESULT Parameters				
Field	Value	Type	Reference	Notes
Identifier	SET [NATIONAL 18]	M	6.3.2.2	
Length	zero octets	M	6.3.2.2	
Contents				

6.4.2.49 Unblocking

The Unblocking operation is used to inform an MSC of the reinsertion into service of a certain circuit.

The Unblocking operation is initiated with a TCAP INVOKE (LAST). This is carried by a TCAP QUERY WITH PERMISSION package. The Parameter Set is encoded as follows:

Table 106 Unblocking INVOKE Parameters

Unblocking INVOKE Parameters				Timer: UBLKT
Field	Value	Type	Reference	Notes
Identifier	SET [NATIONAL 18]	M	6.3.2.1	
Length	variable octets	M	6.3.2.1	
Contents				
	InterMSCCircuitID	M	6.5.2.72	

The Unblocking operation success is reported with a TCAP RETURN RESULT (LAST). This is carried by a TCAP RESPONSE package. The Parameter Set is encoded as follows:

Table 107 Unblocking RETURN RESULT Parameters

Unblocking RETURN RESULT Parameters				
Field	Value	Type	Reference	Notes
Identifier	SET [NATIONAL 18]	M	6.3.2.2	
Length	zero octets	M	6.3.2.2	
Contents				

6.4.2.50 UnreliableRoamerDataDirective

The UnreliableRoamerDataDirective operation is used by the HLR to inform a VLR that it has experienced a failure which has rendered its roaming MS data unreliable.

The UnreliableRoamerDataDirective operation is initiated with a TCAP INVOKE (LAST). This is carried by a TCAP QUERY WITH PERMISSION package. The Parameter Set is encoded as follows:

Table 108 UnreliableRoamerDataDirective INVOKE Parameters

UnreliableRoamerDataDirective INVOKE Parameters				Timer: URDDT
Field	Value	Type	Reference	Notes
Identifier	SET [NATIONAL 18]	M	6.3.2.1	
Length	variable octets	M	6.3.2.1	
Contents				
MSCID (HLR)		O	6.5.2.82	a
SenderIdentificationNumber		O	6.5.2.116	b

Notes:

- a. Include on *IS-41-C* and later.
- b. Include to identify the functional entity sending the message.

The UnreliableRoamerDataDirective operation success is reported with a TCAP RETURN RESULT (LAST). This is carried by a TCAP RESPONSE package. The Parameter Set is encoded as follows:

Table 109 UnreliableRoamerDataDirective RETURN RESULT Parameters

UnreliableRoamerDataDirective RETURN RESULT Parameters				
Field	Value	Type	Reference	Notes
Identifier	SET [NATIONAL 18]	M	6.3.2.2	
Length	Zero octets	M	6.3.2.2	
Contents				

6.4.2.51 UnsolicitedResponse

The UnsolicitedResponse operation is used by a Border MSC to notify neighboring MSCs that an unsolicited or unexpected page response has been received from an MS, that the MS's presence in the Border MSC has been confirmed, and that a TLDN has been assigned.

The UnsolicitedResponse operation is initiated with a TCAP INVOKE (LAST). This is carried by a TCAP QUERY WITH PERMISSION package. The Parameter Set is encoded as follows:

Table 110 UnsolicitedResponse INVOKE Parameters

UnsolicitedResponse INVOKE Parameters				Timer: URT
Field	Value	Type	Reference	Notes
Identifier	SET [NATIONAL 18]	M	6.3.2.1	
Length	variable octets	M	6.3.2.1	
Contents				
BillingID (Anchor)		M	6.5.2.16	
ElectronicSerialNumber		M	6.5.2.63	
MobileIdentificationNumber		M	6.5.2.81	
Digits (Destination)		O	6.5.2.58	a
ExtendedMSCID (Border MSC)		O	6.5.2.64	a
ExtendedSystemMyTypeCode (Border MSC)		O	6.5.2.65	a
PC_SSN (Border MSC)		O	6.5.2.93	a, b
SystemAccessType		O	6.5.2.145	c

Notes:

- a. Include if Temporary Local Directory Number (TLDN) is available.
- b. Include if SS7 is used.
- c. Include for *IS-41-C* or later.

The UnsolicitedResponse operation success is reported with a TCAP RETURN RESULT (LAST). This is carried by a TCAP RESPONSE package. The Parameter Set is encoded as follows:

Table 111 UnsolicitedResponse RETURN RESULT Parameters

UnsolicitedResponse RETURN RESULT Parameters				
Field	Value	Type	Reference	Notes
Identifier	SET [NATIONAL 18]	M	6.3.2.2	
Length	variable octets	M	6.3.2.2	
Contents				
AlertCode		O	6.5.2.3	a
BillingID (Originating)		O	6.5.2.16	b
CallingPartyNumberString1		O	6.5.2.23	c
CallingPartyNumberString2		O	6.5.2.24	c
CallingPartySubaddress		O	6.5.2.25	c
DMH_AccountCodeDigits		O	6.5.2.59	d
DMH_AlternateBillingDigits		O	6.5.2.60	d
DMH_BillingDigits		O	6.5.2.61	d
ExtendedMSCID (Originating MSC)		O	6.5.2.64	e
ExtendedSystemMyTypeCode (Originating MSC)		O	6.5.2.65	f
LegInformation		O	6.5.2.75	g
MobileDirectoryNumber		O	6.5.2.80	d
MSCIdentificationNumber (Originating MSC)		O	6.5.2.83	g
OneTimeFeatureIndicator		O	6.5.2.88	g
PC_SSN (Originating MSC)		O	6.5.2.93	h
PilotBillingID		O	6.5.2.94	g
PilotNumber		O	6.5.2.95	g
RedirectingNumberString		O	6.5.2.108	c
RedirectingSubaddress		O	6.5.2.109	c
TerminationTreatment		O	6.5.2.158	g
TerminationTriggers		O	6.5.2.159	g

Notes:

- a. Include to specify special alerting treatment.
- b. Include for subsequent call redirection at the originating MSC and for recording purposes (see *DMH*).
- c. Include if related feature is active.
- d. Include if available.
- e. Include to identify originating system.
- f. Include to identify originating system manufacturer.
- g. Include if available (e.g., provided in the associated RoutingRequest INVOKE).
- h. Include if SS7 may be used for subsequent call redirection.

6.5 MAP PARAMETERS

6.5.1 General

6.5.1.1 Parameter Format

TIA/EIA-41 MAP uses the TCAP parameter format defined in *ANSI T1.114*.

6.5.1.2 Parameter Identifiers

The following table lists the *TIA/EIA-41* MAP Parameter Identifiers.

Table 112 TIA/EIA-41 MAP Parameter Identifiers

Parameter Identifier Name	Parameter Identifier Code								Reference
	H	G	F	E	D	C	B	A	
BillingID	1	0	0	0	0	0	0	1	6.5.2.16
ServingCellID	1	0	0	0	0	0	1	0	6.5.2.117
TargetCellID	1	0	0	0	0	0	1	1	6.5.2.148
Digits	1	0	0	0	0	1	0	0	6.5.2.58
ChannelData	1	0	0	0	0	1	0	1	6.5.2.47
InterMSCCircuitID	1	0	0	0	0	1	1	0	6.5.2.72
InterSwitchCount	1	0	0	0	0	1	1	1	6.5.2.73
MobileIdentificationNumber	1	0	0	0	1	0	0	0	6.5.2.81
ElectronicSerialNumber	1	0	0	0	1	0	0	1	6.5.2.63
ReleaseReason	1	0	0	0	1	0	1	0	6.5.2.111
SignalQuality	1	0	0	0	1	0	1	1	6.5.2.121
StationClassMark	1	0	0	0	1	1	0	0	6.5.2.143
AuthorizationDenied	1	0	0	0	1	1	0	1	6.5.2.13
AuthorizationPeriod	1	0	0	0	1	1	1	0	6.5.2.14
SeizureType	1	0	0	0	1	1	1	1	6.5.2.115
TrunkStatus	1	0	0	1	0	0	0	0	6.5.2.161
QualificationInformationCode	1	0	0	1	0	0	0	1	6.5.2.99
FeatureResult	1	0	0	1	0	0	1	0	6.5.2.67
RedirectionReason	1	0	0	1	0	0	1	1	6.5.2.110
AccessDeniedReason	1	0	0	1	0	1	0	0	6.5.2.1
MSCID	1	0	0	1	0	1	0	1	6.5.2.82
SystemMyTypeCode	1	0	0	1	0	1	1	0	6.5.2.147
OriginationIndicator	1	0	0	1	0	1	1	1	6.5.2.89

Table 112 (continued)

Parameter Identifier Name	Parameter Identifier Code								Reference
	H	G	F	E	D	C	B	A	
TerminationRestrictionCode	1	0	0	1	1	0	0	0	6.5.2.157
CallingFeaturesIndicator	1	0	0	1	1	0	0	1	6.5.2.20
FaultyParameter	1	0	0	1	1	0	1	0	6.5.2.66
Reserved	1	0	0	1	1	0	1	1	
TDMChannelData	1	0	0	1	1	1	0	0	6.5.2.153
TDMACallMode	1	0	0	1	1	1	0	1	6.5.2.152
HandoffReason	1	0	0	1	1	1	1	0	6.5.2.70
TDMABurstIndicator	1	0	0	1	1	1	1	1	6.5.2.151
	0	0	0	1	1	1	1	1	
PC_SSN	1	0	0	1	1	1	1	1	6.5.2.93
	0	0	1	0	0	0	0	0	
LocationAreaID	1	0	0	1	1	1	1	1	6.5.2.77
	0	0	1	0	0	0	0	1	
SystemAccessType	1	0	0	1	1	1	1	1	6.5.2.145
	0	0	1	0	0	0	1	0	
AuthenticationResponse	1	0	0	1	1	1	1	1	6.5.2.10
	0	0	1	0	0	0	1	1	
AuthenticationResponseBase-Station	1	0	0	1	1	1	1	1	6.5.2.11
	0	0	1	0	0	1	0	0	
AuthenticationResponseUnique-Challenge	1	0	0	1	1	1	1	1	6.5.2.12
	0	0	1	0	0	1	0	1	
CallHistoryCount	1	0	0	1	1	1	1	1	6.5.2.18
	0	0	1	0	0	1	1	0	
ConfidentialityModes	1	0	0	1	1	1	1	1	6.5.2.50
	0	0	1	0	0	1	1	1	
RandomVariable	1	0	0	1	1	1	1	1	6.5.2.101
	0	0	1	0	1	0	0	0	
RandomVariableBaseStation	1	0	0	1	1	1	1	1	6.5.2.102
	0	0	1	0	1	0	0	1	
RandomVariableSSD	1	0	0	1	1	1	1	1	6.5.2.103
	0	0	1	0	1	0	1	0	
RandomVariableUniqueChallenge	1	0	0	1	1	1	1	1	6.5.2.104
	0	0	1	0	1	0	1	1	
ReportType	1	0	0	1	1	1	1	1	6.5.2.112
	0	0	1	0	1	1	0	0	
SignalingMessageEncryptionKey	1	0	0	1	1	1	1	1	6.5.2.120
	0	0	1	0	1	1	0	1	
SharedSecretData	1	0	0	1	1	1	1	1	6.5.2.119
	0	0	1	0	1	1	1	0	
TerminalType	1	0	0	1	1	1	1	1	6.5.2.154
	0	0	1	0	1	1	1	1	
VoicePrivacyMask	1	0	0	1	1	1	1	1	6.5.2.166
	0	0	1	1	0	0	0	0	
SystemCapabilities	1	0	0	1	1	1	1	1	6.5.2.146
	0	0	1	1	0	0	0	1	

Table 112 (continued)

Parameter Identifier Name	Parameter Identifier Code								Reference
	H	G	F	E	D	C	B	A	
DenyAccess	1	0	0	1	1	1	1	1	6.5.2.54
	0	0	1	1	0	0	1	0	
UpdateCount	1	0	0	1	1	1	1	1	6.5.2.163
	0	0	1	1	0	0	1	1	
SSDNotShared	1	0	0	1	1	1	1	1	6.5.2.141
	0	0	1	1	0	1	0	0	
ExtendedMSCID	1	0	0	1	1	1	1	1	6.5.2.64
	0	0	1	1	0	1	0	1	
ExtendedSystemMyTypeCode	1	0	0	1	1	1	1	1	6.5.2.65
	0	0	1	1	0	1	1	0	
ControlChannelData	1	0	0	1	1	1	1	1	6.5.2.51
	0	0	1	1	0	1	1	1	
SystemAccessData	1	0	0	1	1	1	1	1	6.5.2.144
	0	0	1	1	1	0	0	0	
CancellationDenied	1	0	0	1	1	1	1	1	6.5.2.26
	0	0	1	1	1	0	0	1	
BorderCellAccess	1	0	0	1	1	1	1	1	6.5.2.17
	0	0	1	1	1	0	1	0	
CDMAStationClassMark	1	0	0	1	1	1	1	1	6.5.2.41
	0	0	1	1	1	0	1	1	
CDMAServingOneWayDelay	1	0	0	1	1	1	1	1	6.5.2.38
	0	0	1	1	1	1	0	0	
CDMATargetOneWayDelay	1	0	0	1	1	1	1	1	6.5.2.46
	0	0	1	1	1	1	0	1	
CDMACallMode	1	0	0	1	1	1	1	1	6.5.2.29
	0	0	1	1	1	1	1	0	
CDMAChannelData	1	0	0	1	1	1	1	1	6.5.2.30
	0	0	1	1	1	1	1	1	
CDMASignalQuality	1	0	0	1	1	1	1	1	6.5.2.39
	0	1	0	0	0	0	0	0	
CDMAPilotStrength	1	0	0	1	1	1	1	1	6.5.2.35
	0	1	0	0	0	0	0	1	
CDMAMobileProtocolRevision	1	0	0	1	1	1	1	1	6.5.2.34
	0	1	0	0	0	0	1	0	
CDMAPrivateLongCodeMask	1	0	0	1	1	1	1	1	6.5.2.36
	0	1	0	0	0	0	1	1	
CDMACodeChannel	1	0	0	1	1	1	1	1	6.5.2.31
	0	1	0	0	0	1	0	0	
CDMASearchWindow	1	0	0	1	1	1	1	1	6.5.2.37
	0	1	0	0	0	1	0	1	
MSLocation	1	0	0	1	1	1	1	1	6.5.2.84
	0	1	0	0	0	1	1	0	
PageIndicator	1	0	0	1	1	1	1	1	6.5.2.92
	0	1	0	0	0	1	1	1	
ReceivedSignalQuality	1	0	0	1	1	1	1	1	6.5.2.106
	0	1	0	0	1	0	0	0	

Table 112 (continued)

Parameter Identifier Name	Parameter Identifier Code								Reference
	H	G	F	E	D	C	B	A	
DeregistrationType	1	0	0	1	1	1	1	1	6.5.2.55
	0	1	0	0	1	0	0	1	
NAMPSChannelData	1	0	0	1	1	1	1	1	6.5.2.86
	0	1	0	0	1	0	1	0	
AlertCode	1	0	0	1	1	1	1	1	6.5.2.3
	0	1	0	0	1	0	1	1	
AnnouncementCode	1	0	0	1	1	1	1	1	6.5.2.5
	0	1	0	0	1	1	0	0	
AuthenticationAlgorithmVersion	1	0	0	1	1	1	1	1	6.5.2.7
	0	1	0	0	1	1	0	1	
AuthenticationCapability	1	0	0	1	1	1	1	1	6.5.2.8
	0	1	0	0	1	1	1	0	
CallHistoryCountExpected	1	0	0	1	1	1	1	1	6.5.2.19
	0	1	0	0	1	1	1	1	
CallingPartyNumberDigits1	1	0	0	1	1	1	1	1	6.5.2.21
	0	1	0	1	0	0	0	0	
CallingPartyNumberDigits2	1	0	0	1	1	1	1	1	6.5.2.22
	0	1	0	1	0	0	0	1	
CallingPartyNumberString1	1	0	0	1	1	1	1	1	6.5.2.23
	0	1	0	1	0	0	1	0	
CallingPartyNumberString2	1	0	0	1	1	1	1	1	6.5.2.24
	0	1	0	1	0	0	1	1	
CallingPartySubaddress	1	0	0	1	1	1	1	1	6.5.2.25
	0	1	0	1	0	1	0	0	
CancellationType	1	0	0	1	1	1	1	1	6.5.2.27
	0	1	0	1	0	1	0	1	
CarrierDigits	1	0	0	1	1	1	1	1	6.5.2.28
	0	1	0	1	0	1	1	0	
DestinationDigits	1	0	0	1	1	1	1	1	6.5.2.56
	0	1	0	1	0	1	1	1	
DMH_RedirectionIndicator	1	0	0	1	1	1	1	1	6.5.2.62
	0	1	0	1	1	0	0	0	
IntersystemTermination	1	0	1	1	1	1	1	1	6.5.2.74
	0	1	0	1	1	0	0	1	
AvailabilityType	1	0	0	1	1	1	1	1	6.5.2.15
	0	1	0	1	1	0	1	0	
LocalTermination	1	0	1	1	1	1	1	1	6.5.2.76
	0	1	0	1	1	0	1	1	
MessageWaitingNotificationCount	1	0	0	1	1	1	1	1	6.5.2.78
	0	1	0	1	1	1	0	0	
MobileDirectoryNumber	1	0	0	1	1	1	1	1	6.5.2.80
	0	1	0	1	1	1	0	1	
MSCIdentificationNumber	1	0	0	1	1	1	1	1	6.5.2.83
	0	1	0	1	1	1	1	0	
PSTNTermination	1	0	1	1	1	1	1	1	6.5.2.98
	0	1	0	1	1	1	1	1	

Table 112 (continued)

Parameter Identifier Name	Parameter Identifier Code								Reference
	H	G	F	E	D	C	B	A	
NoAnswerTime	1	0	0	1	1	1	1	1	6.5.2.87
OneTimeFeatureIndicator	1	0	0	1	1	1	1	1	6.5.2.88
OriginationTriggers	1	0	0	1	1	1	1	1	6.5.2.90
RANDC	1	0	0	1	1	1	1	1	6.5.2.100
RedirectingNumberDigits	1	0	0	1	1	1	1	1	6.5.2.107
RedirectingNumberString	1	0	0	1	1	1	1	1	6.5.2.108
RedirectingSubaddress	1	0	0	1	1	1	1	1	6.5.2.109
SenderIdIdentificationNumber	1	0	0	1	1	1	1	1	6.5.2.116
SMS_Address	1	0	0	1	1	1	1	1	6.5.2.123
SMS_BearerData	1	0	0	1	1	1	1	1	6.5.2.124
SMS_ChargeIndicator	1	0	0	1	1	1	1	1	6.5.2.126
SMS_DestinationAddress	1	0	0	1	1	1	1	1	6.5.2.127
SMS_MessageCount	1	0	0	1	1	1	1	1	6.5.2.128
SMS_NotificationIndicator	1	0	0	1	1	1	1	1	6.5.2.130
SMS_OriginalDestinationAddress	1	0	0	1	1	1	1	1	6.5.2.131
SMS_OriginalDestination-Subaddress	1	0	0	1	1	1	1	1	6.5.2.132
SMS_OriginalOriginatingAddress	1	0	0	1	1	1	1	1	6.5.2.133
SMS_OriginalOriginating-Subaddress	1	0	0	1	1	1	1	1	6.5.2.134
SMS_OriginatingAddress	1	0	0	1	1	1	1	1	6.5.2.135
SMS_OriginationRestrictions	1	0	0	1	1	1	1	1	6.5.2.136
SMS_TeleserviceIdentifier	1	0	0	1	1	1	1	1	6.5.2.137
SMS_TerminationRestrictions	1	0	0	1	1	1	1	1	6.5.2.138
SMS_MessageWaitingIndicator	1	0	0	1	1	1	1	1	6.5.2.129

Table 112 (continued)

Parameter Identifier Name	Parameter Identifier Code								Reference
	H	G	F	E	D	C	B	A	
TerminationAccessType	1	0	0	1	1	1	1	1	6.5.2.155
	0	1	1	1	0	1	1	1	
TerminationList	1	0	1	1	1	1	1	1	6.5.2.156
	0	1	1	1	1	0	0	0	
TerminationTreatment	1	0	0	1	1	1	1	1	6.5.2.158
	0	1	1	1	1	0	0	1	
TerminationTriggers	1	0	0	1	1	1	1	1	6.5.2.159
	0	1	1	1	1	0	1	0	
TransactionCapability	1	0	0	1	1	1	1	1	6.5.2.160
	0	1	1	1	1	0	1	1	
UniqueChallengeReport	1	0	0	1	1	1	1	1	6.5.2.162
	0	1	1	1	1	1	0	0	
Reserved	1	0	0	1	1	1	1	1	
	0	1	1	1	1	1	0	1	
Reserved	1	0	0	1	1	1	1	1	
	0	1	1	1	1	1	1	0	
Reserved	1	0	0	1	1	1	1	1	
	0	1	1	1	1	1	1	1	
ActionCode	1	0	0	1	1	1	1	1	6.5.2.2
	1	0	0	0	0	0	0	1	
	0	0	0	0	0	0	0	0	
AlertResult	1	0	0	1	1	1	1	1	6.5.2.4
	1	0	0	0	0	0	0	1	
	0	0	0	0	0	0	0	1	
AnnouncementList	1	0	1	1	1	1	1	1	6.5.2.6
	1	0	0	0	0	0	0	1	
	0	0	0	0	0	0	1	0	
CDMACodeChannelInformation	1	0	1	1	1	1	1	1	6.5.2.32
	1	0	0	0	0	0	0	1	
	0	0	0	0	0	0	1	1	
CDMACodeChannelList	1	0	1	1	1	1	1	1	6.5.2.33
	1	0	0	0	0	0	0	1	
	0	0	0	0	0	1	0	0	
CDMATargetMeasurement- Information	1	0	1	1	1	1	1	1	6.5.2.44
	1	0	0	0	0	0	0	1	
	0	0	0	0	0	1	0	1	
CDMATargetMeasurementList	1	0	1	1	1	1	1	1	6.5.2.45
	1	0	0	0	0	0	0	1	
	0	0	0	0	0	1	1	0	
CDMATargetMAHOInformation	1	0	1	1	1	1	1	1	6.5.2.42
	1	0	0	0	0	0	0	1	
	0	0	0	0	0	1	1	1	
CDMATargetMAHOList	1	0	1	1	1	1	1	1	6.5.2.43
	1	0	0	0	0	0	0	1	
	0	0	0	0	1	0	0	0	
ConferenceCallingIndicator	1	0	0	1	1	1	1	1	6.5.2.49
	1	0	0	0	0	0	0	1	
	0	0	0	0	1	0	0	1	

Table 112 (continued)

Parameter Identifier Name	Parameter Identifier Code								Reference
	H	G	F	E	D	C	B	A	
CountUpdateReport	1	0	0	1	1	1	1	1	6.5.2.52
	1	0	0	0	0	0	0	1	
	0	0	0	0	1	0	1	0	
DigitCollectionControl	1	0	0	1	1	1	1	1	6.5.2.57
	1	0	0	0	0	0	0	1	
	0	0	0	0	1	0	1	1	
DMH_AccountCodeDigits	1	0	0	1	1	1	1	1	6.5.2.59
	1	0	0	0	0	0	0	1	
	0	0	0	0	1	1	0	0	
DMH_AlternateBillingDigits	1	0	0	1	1	1	1	1	6.5.2.60
	1	0	0	0	0	0	0	1	
	0	0	0	0	1	1	0	1	
DMH_BillingDigits	1	0	0	1	1	1	1	1	6.5.2.61
	1	0	0	0	0	0	0	1	
	0	0	0	0	1	1	1	0	
GeographicAuthorization	1	0	0	1	1	1	1	1	6.5.2.68
	1	0	0	0	0	0	0	1	
	0	0	0	0	1	1	1	1	
LegInformation	1	0	0	1	1	1	1	1	6.5.2.75
	1	0	0	0	0	0	0	1	
	0	0	0	1	0	0	0	0	
MessageWaitingNotificationType	1	0	0	1	1	1	1	1	6.5.2.79
	1	0	0	0	0	0	0	1	
	0	0	0	1	0	0	0	1	
PACAIndicator	1	0	0	1	1	1	1	1	6.5.2.91
	1	0	0	0	0	0	0	1	
	0	0	0	1	0	0	1	0	
PreferredLanguageIndicator	1	0	0	1	1	1	1	1	6.5.2.96
	1	0	0	0	0	0	0	1	
	0	0	0	1	0	0	1	1	
RANDValidTime	1	0	0	1	1	1	1	1	6.5.2.105
	1	0	0	0	0	0	0	1	
	0	0	0	1	0	1	0	0	
RestrictionDigits	1	0	0	1	1	1	1	1	6.5.2.113
	1	0	0	0	0	0	0	1	
	0	0	0	1	0	1	0	1	
RoutingDigits	1	0	0	1	1	1	1	1	6.5.2.114
	1	0	0	0	0	0	0	1	
	0	0	0	1	0	1	1	0	
SetupResult	1	0	0	1	1	1	1	1	6.5.2.118
	1	0	0	0	0	0	0	1	
	0	0	0	1	0	1	1	1	
SMS_AccessDeniedReason	1	0	0	1	1	1	1	1	6.5.2.122
	1	0	0	0	0	0	0	1	
	0	0	0	1	1	0	0	0	
SMS_CauseCode	1	0	0	1	1	1	1	1	6.5.2.125
	1	0	0	0	0	0	0	1	
	0	0	0	1	1	0	0	1	

Table 112 (continued)

Parameter Identifier Name	Parameter Identifier Code								Reference
	H	G	F	E	D	C	B	A	
SPINIPIN	1	0	0	1	1	1	1	1	6.5.2.139
	1	0	0	0	0	0	0	1	
	0	0	0	1	1	0	1	0	
SPINITriggers	1	0	0	1	1	1	1	1	6.5.2.140
	1	0	0	0	0	0	0	1	
	0	0	0	1	1	0	1	1	
SSDUpdateReport	1	0	0	1	1	1	1	1	6.5.2.142
	1	0	0	0	0	0	0	1	
	0	0	0	1	1	1	0	0	
TargetMeasurementInformation	1	0	1	1	1	1	1	1	6.5.2.149
	1	0	0	0	0	0	0	1	
	0	0	0	1	1	1	0	1	
TargetMeasurementList	1	0	1	1	1	1	1	1	6.5.2.150
	1	0	0	0	0	0	0	1	
	0	0	0	1	1	1	1	0	
VoiceMailboxPIN	1	0	0	1	1	1	1	1	6.5.2.165
	1	0	0	0	0	0	0	1	
	0	0	0	1	1	1	1	1	
VoiceMailboxNumber	1	0	0	1	1	1	1	1	6.5.2.164
	1	0	0	0	0	0	0	1	
	0	0	1	0	0	0	0	0	
AuthenticationData	1	0	0	1	1	1	1	1	6.5.2.9
	1	0	0	0	0	0	0	1	
	0	0	1	0	0	0	0	1	
ConditionallyDeniedReason	1	0	0	1	1	1	1	1	6.5.2.48
	1	0	0	0	0	0	0	1	
	0	0	1	0	0	0	1	0	
GroupInformation	1	0	0	1	1	1	1	1	6.5.2.69
	1	0	0	0	0	0	0	1	
	0	0	1	0	0	0	1	1	
HandoffState	1	0	0	1	1	1	1	1	6.5.2.71
	1	0	0	0	0	0	0	1	
	0	0	1	0	0	1	0	0	
NAMPSCallMode	1	0	0	1	1	1	1	1	6.5.2.85
	1	0	0	0	0	0	0	1	
	0	0	1	0	0	1	0	1	
CDMASlotCycleIndex	1	0	0	1	1	1	1	1	6.5.2.40
	1	0	0	0	0	0	0	1	
	0	0	1	0	0	1	1	0	
DeniedAuthorizationPeriod	1	0	0	1	1	1	1	1	6.5.2.53
	1	0	0	0	0	0	0	1	
	0	0	1	0	0	1	1	1	
PilotNumber	1	0	0	1	1	1	1	1	6.5.2.95
	1	0	0	0	0	0	0	1	
	0	0	1	0	1	0	0	0	
PilotBillingID	1	0	0	1	1	1	1	1	6.5.2.94
	1	0	0	0	0	0	0	1	
	0	0	1	0	1	0	0	1	

Table 112 (concluded)

Parameter Identifier Name	Parameter Identifier Code								Reference
	H	G	F	E	D	C	B	A	
Other values are reserved	X	X	X	X	X	X	X	X	
Reserved for National Network use.	1	0	X	1	1	1	1	1	See Note a. See Note b for value of X.
	1	1	1	1	1	1	1	0	
	0	1	1	1	0	1	1	0	
Reserved for National Network use.	1	0	X	1	1	1	1	1	See Note a. See Note b for value of X.
	1	1	1	1	1	1	1	0	
	0	1	1	1	0	1	1	1	
Reserved for National Network use.	1	0	X	1	1	1	1	1	See Note a. See Note b for value of X.
	1	1	1	1	1	1	1	0	
	0	1	1	1	1	0	0	0	
Reserved for National Network use.	1	0	X	1	1	1	1	1	See Note a. See Note b for value of X.
	1	1	1	1	1	1	1	0	
	0	1	1	1	1	0	1	0	
Reserved for National Network use.	1	0	X	1	1	1	1	1	See Note a. See Note b for value of X.
	1	1	1	1	1	1	1	0	
	0	1	1	1	1	0	1	0	
Reserved for National Network use.	1	0	X	1	1	1	1	1	See Note a. See Note b for value of X.
	1	1	1	1	1	1	1	0	
	0	1	1	1	1	0	1	1	
Reserved for National Network use.	1	0	X	1	1	1	1	1	See Note a. See Note b for value of X.
	1	1	1	1	1	1	1	0	
	0	1	1	1	1	1	0	0	
MobileAdditionalParty'sCategory3	1	0	0	1	1	1	1	1	6.5.2.J3 See Note a.
	1	1	1	1	1	1	1	0	
	0	1	1	1	1	1	0	1	
CarrierIdentificationCode	1	0	0	1	1	1	1	1	6.5.2.J2 See Note a.
	1	1	1	1	1	1	1	0	
	0	1	1	1	1	1	1	0	
ChargingAreaInformation	1	0	0	1	1	1	1	1	6.5.2.J1 See Note a.
	1	1	1	1	1	1	1	0	
	0	1	1	1	1	1	1	1	
Reserved for Protocol Extension	1	0	0	1	1	1	1	1	
	1	1	1	1	1	1	1	1	
	0	0	0	0	0	0	0	0	
	...								
	1	0	0	1	1	1	1	1	
1	1	1	1	1	1	1	1		
0	1	1	1	1	1	1	1		

Notes :

- a. "National Network use" parameters may be independently used by each nation.
"National Network use" parameters may be used between nations by bilateral agreement.
- b. The Parameter Identifier Code first octet's bit="F" is variable (e.g., set=0 for Primitive elements and set=1 for Constructor elements), see *ANSI T1.114*.

6.5.2 Parameter Definitions

This Section provides the definitions of the parameters used in this specification.

6.5.2.1 AccessDeniedReason

The AccessDeniedReason (ACCDEN) parameter indicates the reason access cannot be given to the called MS.

Field	Value	Type	Reference	Notes					
Identifier	AccessDeniedReason IMPLICIT Unsigned Enumerated	M	6.5.1.2						
Length	1 octet	M	6.5.1.1						
Contents									
H	G	F	E	D	C	B	A	octet	Notes
AccessDeniedReason								1	

Figure 8 AccessDeniedReason parameter

Table 113 AccessDeniedReason value

<i>AccessDeniedReason (octet 1)</i>										
Bits	H	G	F	E	D	C	B	A	Value	Meaning
	0	0	0	0	0	0	0	0	0	Not used.
	0	0	0	0	0	0	0	1	1	Unassigned directory Number (the MS is not served by the accessed system).
	0	0	0	0	0	0	1	0	2	Inactive (the MS is not active in the accessed system and the HLR pointer to the MS's VLR should be maintained).
	0	0	0	0	0	0	1	1	3	Busy (the MS is busy in the accessed system and cannot accept additional calls).
	0	0	0	0	0	1	0	0	4	Termination Denied (terminations to this MS are not allowed).
	0	0	0	0	0	1	0	1	5	No Page Response (the MS was paged by the accessed system but did not respond).
	0	0	0	0	0	1	1	0	6	Unavailable (the MS is currently not available and the HLR pointer to the MS's VLR should be maintained and the MS shall remain in the same state).
	0	0	0	0	0	1	1	1	7	} Reserved. Treat the same as value 4, <i>Termination Denied</i> .
	1	1	0	1	1	1	1	1	through 223	
	1	1	1	0	0	0	0	0	224	} Reserved for TIA/EIA-41 protocol extension. If unknown, treat the same as value 4, <i>Termination Denied</i> .
	1	1	1	1	1	1	1	1	through 255	

6.5.2.2 ActionCode

The ActionCode (ACTCODE) parameter specifies the nature of the action (e.g., disconnect the call) to be performed by the designated functional entity.

Field	Value	Type	Reference	Notes					
Identifier	ActionCode IMPLICIT OCTET STRING	M	6.5.1.2						
Length	variable octets	M	6.5.1.1						
Contents									
H	G	F	E	D	C	B	A	octet	Notes
Action									
...								<i>n</i>	<i>a</i>

Figure 9 ActionCode parameter

Notes:

- a. Ignore extra octets, if received. Send only defined (or significant) octets.

Table 114 ActionCode value

<i>Action (octet 1)</i>										
Bits	H	G	F	E	D	C	B	A	Value	Meaning
	0	0	0	0	0	0	0	0	0	Not used.
	0	0	0	0	0	0	0	1	1	Continue processing.
	0	0	0	0	0	0	1	0	2	Disconnect call.
	0	0	0	0	0	0	1	1	3	Disconnect call leg.
	0	0	0	0	0	1	0	0	4	Conference Calling Drop Last Party.
	0	0	0	0	0	1	0	1	5	Bridge call leg(s) to conference call.
	0	0	0	0	0	1	1	0	6	Drop call leg on busy or routing failure.
	0	0	0	0	0	1	1	1	7	Disconnect all call legs.
	0	0	0	0	1	0	0	0	8	} Reserved. Treat the same as value 1, <i>Continue processing.</i>
				...					through 95	
	0	1	0	1	1	1	1	1	96	} Reserved for TIA/EIA-41 protocol extension. If unknown, treat the same as value 1, <i>Continue processing.</i>
				...					through 127	
	1	0	0	0	0	0	0	0	128	} Reserved. Treat the same as value 2, <i>Disconnect call.</i>
				...					through 223	
	1	1	1	0	0	0	0	0	224	} Reserved for TIA/EIA-41 protocol extension. If unknown, treat the same as value 2, <i>Disconnect call.</i>
				...					through 255	
	1	1	1	1	1	1	1	1	255	

6.5.2.3 AlertCode

The AlertCode (ALRTCODE) parameter specifies the pitch and cadence of an alert signal to be applied to a designated MS.

The minimum length of this parameter is 2 octets.

Field	Value	Type	Reference	Notes					
Identifier	AlertCode IMPLICIT OCTET STRING	M	6.5.1.2						
Length	variable octets	M	6.5.1.1						
Contents									
H	G	F	E	D	C	B	A	octet	Notes
Pitch		Cadence						1	
Reserved						Alert Action		2	a
...								<i>n</i>	b

Figure 10 AlertCode parameter

Notes:

- a. Reserved bits shall be ignored on receipt and set to zero on sending.
- b. Ignore extra octets, if received. Send only defined (or significant) octets.

Table 115 AlertCode Value

<i>Pitch (octet 1, bits G-H)</i>										
Bits	H	G	F	E	D	C	B	A	Value	Meaning
	0	0							0	Medium pitch for normal alerting.
	0	1							1	High Pitch.
	1	0							2	Low Pitch.
	1	1							3	Reserved.
<i>Alert Action (octet 2, bits A-C)</i>										
Bits	H	G	F	E	D	C	B	A	Value	Meaning
						0	0	0	0	Alert without waiting to report.
						0	0	1	1	Apply a reminder alert once (ignore the pitch and cadence) and wait for success or failure.
						0	1	0	2	} Other values reserved. Treat the same as value 0, <i>Alert without waiting to report.</i>
						...			through	
						1	1	1	7	
	X	X	X							Other values reserved. Treat the same as value 000 <i>Alert without waiting to report.</i>

Table 115 (concluded)

Cadence (octet 1, bits A-F)										
Bits	H	G	F	E	D	C	B	A	Value	Meaning
			0	0	0	0	0	0	0	NoTone . Used to stop alerting in progress.
			0	0	0	0	0	1	1	Long (2.0 s on, 4.0 s off, repeating). Used for normal alerting.
			0	0	0	0	1	0	2	ShortShort (0.8 s on, 0.4 s off, 0.8 s on, 4.0 s off, repeating). Used for distinctive alerting 1.
			0	0	0	0	1	1	3	ShortShortLong (0.4 s on, 0.2 s off, 0.4 s on, 0.2 s off, 0.8 s on, 4.0 s off, repeating). Used for distinctive alerting 2, automatic callback, and automatic recall.
			0	0	0	1	0	0	4	ShortShort2 (1.0 s on, 1.0 s off, 1.0 s on, 3.0 s off, repeating). Used for coded ringing.
			0	0	0	1	0	1	5	ShortLongShort (0.5 s on, 0.5 s off, 1.0 s on, 0.5 s off, 0.5 s on, 3.0 s off, repeating). Used for distinctive alerting 3.
			0	0	0	1	1	0	6	ShortShortShortShort (0.5 s on, 0.5 s off, 0.5 s on, 0.5 s off, 0.5 s on, 0.5 s off, 0.5 s on, 2.5 s off, repeating). Used for executive override and preemption.
			0	0	0	1	1	1	7	PBXLong (1.0 s on, 2.0 s off, repeating). Used for normal PBX alerting.
			0	0	1	0	0	0	8	PBXShortShort (0.4 s on, 0.2 s off, 0.4 s on, 2.0 s off, repeating). Used for PBX distinctive alerting 1.
			0	0	1	0	0	1	9	PBXShortShortLong (0.4 s on, 0.2 s off, 0.4 s on, 0.2 s off, 0.8 s on, 1.0 s off, repeating). Used for PBX distinctive alerting 2 and PBX automatic callback.
			0	0	1	0	1	0	10	PBXShortLongShort (0.4 s on, 0.2 s off, 0.8 s on, 0.2 s off, 0.4 s on, 1.0 s off, repeating). Used for PBX distinctive alerting 3.
			0	0	1	0	1	1	11	PBXShortShortShortShort (0.4 s on, 0.2 s off, 0.4 s on, 0.2 s off, 0.4 s on, 0.2 s off, 0.4 s, 0.8 s off, repeating). Used for PBX executive override and PBX preemption.
			0	0	1	1	0	0	12	PipPipPipPip (0.1 s on, 0.1 s off, 0.1 s on, 0.1 s off, 0.1 s on, 0.1 s off, 0.1 s on). Used for alert pip tone.
			0	0	1	1	0	1	13	} Reserved. Treat the same as value 0, <i>NoTone</i> .
			...					through		
			1	1	1	1	1	1	63	

6.5.2.4 AlertResult

The AlertResult (ALRTRES) parameter indicates the result of the alerting action attempted by the designated functional entity. It is returned when a result is requested in the AlertCode parameter (as indicated in the Alert Action field of the AlertCode parameter).

Field	Value	Type	Reference	Notes					
Identifier	AlertResult IMPLICIT OCTET STRING	M	6.5.1.2						
Length	variable octets	M	6.5.1.1						
Contents									
H	G	F	E	D	C	B	A	octet	Notes
Result								1	
...								<i>n</i>	<i>a</i>

Figure 11 AlertResult parameter

Notes:

- a. Ignore extra octets, if received. Send only defined (or significant) octets.

Table 116 AlertResult value

Result (octet 1)										
Bits	H	G	F	E	D	C	B	A	Value	Meaning
	0	0	0	0	0	0	0	0	0	Not specified.
	0	0	0	0	0	0	0	1	1	Success.
	0	0	0	0	0	0	1	0	2	Failure.
	0	0	0	0	0	0	1	1	3	Denied. The requested action was not authorized and was not attempted.
	0	0	0	0	0	1	0	0	4	NotAttempted. The requested action could not be attempted at this time due to congestion or other temporary failure.
	0	0	0	0	0	1	0	1	5	NoPageResponse. The alerted MS did not respond to paging.
	0	0	0	0	0	1	1	0	6	Busy. The requested action not attempted due to MS busy.
	0	0	0	0	0	1	1	1	7	} Reserved. Treat the same as value 0, <i>Not specified.</i>
				• •					through	
	1	1	1	1	1	1	1	1	255	

6.5.2.5 AnnouncementCode

The AnnouncementCode (ANNCODE) parameter specifies the announcement or tone to be given to a designated party.

Field	Value	Type	Reference	Notes					
Identifier	AnnouncementCode IMPLICIT OCTET STRING	M	6.5.1.2						
Length	variable octets	M	6.5.1.1	a					
Contents									
H	G	F	E	D	C	B	A	octet	Notes
Tone								1	b, c
Reserved				Class				2	d
Standard Announcement								3	
Custom Announcement								4	e
...								n	f

Figure 12 AnnouncementCode parameter

Notes:

- a. The length is variable with more specific requests in the later octets. The minimum length is one octet.
- b. The tone is applied if an announcement is not specified or if the specified announcement is not available.
- c. This is based on the *ANSI T1.607 (Q.931)* Signal parameter and includes "network specific values" [*N-ISDN*]. It should not be used for alerting purposes; use the AlertCode instead.
- d. Reserved bits shall be ignored on receipt and set to zero on sending.
- e. The assignment of this octet is left to bilateral agreement. When a Custom Announcement is specified it takes precedence over either the Standard Announcement or Tone.
- f. Ignore extra octets, if received. Send only defined (or significant) octets.

Table 117 AnnouncementCode value

Tone (octet 1)											
Bits	H	G	F	E	D	C	B	A	Value	Meaning	
	0	0	0	0	0	0	0	0	0	DialTone. A continuous 350 Hz tone added to a 440 Hz tone.(Note 1)	*
	0	0	0	0	0	0	0	1	1	RingBack or AudibleAlerting. A 440 Hz tone added to a 480 Hz tone repeated in a 2s on 4s off pattern. (Note 1)	*
	0	0	0	0	0	0	1	0	2	InterceptTone or MobileReorder. Alternating 440 Hz and 620 Hz tones, each on for 250 ms. (Note 2)	*
	0	0	0	0	0	0	1	1	3	CongestionTone or ReorderTone. A 480 Hz tone added to a 620 Hz tone repeated in a 250 ms on, 250 ms off cycle. (Note 2)	*
	0	0	0	0	0	1	0	0	4	BusyTone. A 480 Hz tone added to a 620 Hz tone repeated in a 500 ms on, 500 ms off cycle. (Note 1)	*
	0	0	0	0	0	1	0	1	5	ConfirmationTone. A 350 Hz tone added to a 440 Hz tone repeated 3 times in a 100 ms on, 100 ms off cycle.(Note 2)	*
	0	0	0	0	0	1	1	0	6	AnswerTone. Answer tone is not presently used in North American networks. (Note 2)	*
	0	0	0	0	0	1	1	1	7	CallWaitingTone. A single 300 ms burst of 440 Hz tone. (Note 2)	*
	0	0	0	0	1	0	0	0	8	OffHookTone. Off-hook warning tone on. (Note 2)	*
	0	0	0	1	0	0	0	1	17	RecallDialTone. Three bursts (0.1 s on, 0.1s off) then steady on of dial tone. <i>[N-ISDN]</i> (Note 2)	*
	0	0	0	1	0	0	1	0	18	BargeInTone. No information available. <i>[N-ISDN]</i> (Note 2)	*
	0	0	1	1	1	1	1	1	63	TonesOff. All tones off. (Note 2)	
	1	1	0	0	0	0	0	0	192	PipTone. Four bursts of (0.1 s on, 0.1 s off) of 480 Hz tone, then off. <i>[TIA/EIA-664]</i> (Note 2)	*
	1	1	0	0	0	0	0	1	193	AbbreviatedIntercept. 4 seconds of Intercept-Tone. <i>[CDMA]</i> (Note 2)	*
	1	1	0	0	0	0	1	0	194	AbbreviatedCongestion. 4 seconds of CongestionTone. <i>[CDMA]</i> (Note 2)	*
	1	1	0	0	0	0	1	1	195	WarningTone. A single 0.1 s burst of 480 Hz tone. <i>[TIA/EIA-664]</i> (Note 2)	*
	1	1	0	0	0	1	0	0	196	DenialToneBurst. A single 2.0 s burst of 480 Hz tone added to a 620 Hz tone. <i>[TIA/EIA-664]</i> (Note 2)	*
	1	1	0	0	0	1	0	1	197	DialToneBurst. A single 2.0 s burst of DialTone. <i>[TIA/EIA-664]</i> (Note 2)	*
	1	1	1	1	1	0	1	0	250	IncomingAdditionalCallTone. No information available. <i>[N-ISDN]</i> (Note 2)	*
	1	1	1	1	1	0	1	1	251	PriorityAdditionalCallTone. No information available. <i>[N-ISDN]</i> (Note 2)	*
	X	X	X	X	X	X	X	X		Other values are reserved. Treat the same as value 63, <i>TonesOff.</i>	*

Table 117 (continued)

<i>Class (octet 2, bits A-D)</i>										
Bits	H	G	F	E	D	C	B	A	Value	Meaning
					0	0	0	0	0	Concurrent. Play announcements concurrently with any call routing.
					0	0	0	1	1	Sequential. Play all announcements before any call termination or routing.
					0	0	1	0	2	} Reserved. Treat the same as value 0, <i>Concurrent</i> .
					...				through	
					0	1	1	1	7	
					1	0	0	0	8	} Reserved. Treat the same as value 1, <i>Sequential</i> .
					...				through	
					1	1	1	1	15	
<i>Standard Announcement (octet 3)</i>										
Bits	H	G	F	E	D	C	B	A	Value	Meaning (Note 3)
	0	0	0	0	0	0	0	0	0	None. No announcement is requested, just play the tone.
	0	0	0	0	0	0	0	1	1	UnauthorizedUser. (e.g., "Your cellular telephone's serial number has been restricted from this service area. If you feel this is an error, please contact your home cellular provider.")
	0	0	0	0	0	0	1	0	2	InvalidESN. (e.g., "You cannot make a call because of conflicting serial number data. Please call your customer service representative by dialing (*) 611.")
	0	0	0	0	0	0	1	1	3	UnauthorizedMobile. An MS attempts to originate a call for an unauthorized subscriber. (e.g., "There is no service agreement between the serving service provider and the home service provider.")
	0	0	0	0	0	1	0	0	4	SuspendedOrigination. (e.g., "Your service has been temporarily disconnected. For more information, call your customer service representative by dialing (*) 611.")
	0	0	0	0	0	1	0	1	5	OriginationDenied. The subscriber attempted to originate a call that is denied by its service profile. (e.g., "You cannot make a call from this cellular telephone. You can only receive calls with your type of service.")
	0	0	0	0	0	1	1	0	6	ServiceAreaDenial. The subscriber attempted a call that is not permitted in the current service area. (e.g., "You cannot make that call from this service area. For more information, call your customer service representative by dialing (*) 611.")
	0	0	0	1	0	0	0	0	16	PartialDial. The subscriber dialed insufficient digits to complete routing. The Reorder SIT may apply. Alternatively reorder tone may apply. (e.g., "Your call cannot be completed as dialed. Please try your call again.") [NoLECN]
	0	0	0	1	0	0	0	1	17	Require1Plus. The subscriber dialed a toll network without dialing a '1' digit prefix. (e.g., "It is necessary to first dial a one when calling this number. Please try your call again.")

*

Table 117 (continued)

1											
2											
3		0	0	0	1	0	0	1	0	18	Require1PlusNPA. A roaming subscriber attempted to dial a seven-digit call that is likely to be a toll call, but the call is not permitted. (e.g., "It is necessary to dial a one plus the area code and phone number of the party you are calling when calling from this service area. Please try your call again.") [TIA/EIA-660]
4											
5											
6											
7											
8											
9		0	0	0	1	0	0	1	1	19	Require0Plus. (e.g., "It is not possible to provide toll service at this time. You may place credit card, collect or third party long distance calls by dialing '0', area code and number. Please try your call again.")
10											
11											
12											
13											
14		0	0	0	1	0	1	0	0	20	Require0PlusNPA. (e.g., "It is necessary to first dial a zero plus the area code and phone number of the party you are calling to complete a long distance call from this service area. Please try your call again.")
15											
16											
17											
18		0	0	0	1	0	1	0	1	21	Deny1Plus. The subscriber dialed a local number prefixed with a 1 digit. (e.g., "It is not necessary to dial a one when calling this number. Please try your call again.") [TIA/EIA-660]
19											
20											
21											
22											
23		0	0	0	1	0	1	1	0	22	Unsupported10Plus. (e.g., "Long distance carrier access codes are not supported on this system.")
24											
25											
26		0	0	0	1	0	1	1	1	23	Deny10Plus. (e.g., "You are not authorized to dial long distance access codes.") [TIA/EIA-660]
27											
28											
29		0	0	0	1	1	0	0	0	24	Unsupported10XXX. (e.g., "The long distance access code you have dialed is not accessible on this system. Please call your long distance provider's customer service number for assistance.") [TIA/EIA-660]
30											
31											
32											
33											
34		0	0	0	1	1	0	0	1	25	Deny10XXX. (e.g., "The long distance access code you have dialed is not authorized on this system.") [TIA/EIA-660]
35											
36											
37		0	0	0	1	1	0	1	0	26	Deny10XXXLocally. (e.g., "A carrier access code is not required for the number you have dialed. Please try your call again without the carrier access code.")
38											
39											
40											
41		0	0	0	1	1	0	1	1	27	Require10Plus. (e.g., "A carrier access code is required for the number you have dialed. Please dial the call again with the carrier access code.") [NoLECN]
42											
43											
44		0	0	0	1	1	1	0	0	28	RequireNPA. (e.g., "While roaming on this system, you are required to include the area code of the number you are calling to complete local calls.")
45											
46											
47											
48		0	0	0	1	1	1	0	1	29	DenyTollOrigination. The subscriber attempted a toll call that is not permitted by its service profile. (e.g., "At the present time we are not able to offer toll service to roamers.") [TIA/EIA-41]
49											
50											
51											
52											
53		0	0	0	1	1	1	1	0	30	DenyInternationalOrigination. The subscriber attempted an international call that is not permitted by its service profile. (e.g., "At the present time we are not able to offer international service to roamers. You may place credit card calls by dialing '0' and the appropriate access code and phone number.") [TIA/EIA-41]
54											
55											
56											
57											
58											
59											
60											

Table 117 (continued)

0	0	0	1	1	1	1	1	31	Deny0Minus. The subscriber attempted to dial a 0- call that is not permitted by its service profile. (e.g., "At the present time we are not able to offer operator services.")
0	0	1	1	0	0	0	0	48	DenyNumber. (e.g., "Your service does not allow calls to the number you have dialed. For more information please call your customer service representative by dialing (*) 611.") [TIA/EIA-41]
0	0	1	1	0	0	0	1	49	AlternateOperatorServices. (e.g., "Your call is being processed by a cellular operator service. Use of a credit or calling card is required.")
0	1	0	0	0	0	0	0	64	NoCircuit or AllCircuitBusy or FacilityProblem. There are no available outgoing trunks (or other facilities) for the terminating route. The No Circuit SIT may apply. Alternatively reorder tone may apply. (e.g., All circuits are busy now. Please try again later.)
0	1	0	0	0	0	0	1	65	OverLoad. There are no available outgoing trunks (or other facilities) for the terminating route due to heavy calling. (e.g., "All circuits are busy now due to heavy calling. Please try again later. If your call is urgent, please try again now.") [T1.209]
0	1	0	0	0	0	1	0	66	InternalOfficeFailure. The Reorder SIT may apply. Alternatively reorder tone may apply. (e.g., "Your call did not go through. Please try again later.") [NoLECN]
0	1	0	0	0	0	1	1	67	NoWinkRecieved. The Reorder SIT may apply. Alternatively reorder tone may apply. (e.g., "Your call did not go through. Please try again later.") [NoLECN]
0	1	0	0	0	1	0	0	68	InterOfficeLinkFailure. The Reorder SIT may apply. Alternatively reorder tone may apply. (e.g., "Your call did not go through. Please try again later.") [NoLECN]
0	1	0	0	0	1	0	1	69	Vacant. The subscriber dialed an unassigned area code, office code, X11 service code, out-of-area call, or country code. The Vacant Code SIT may apply. (e.g., "Your call cannot be completed as dialed. Please check the number and dial again.") [NoLECN]
0	1	0	0	0	1	1	0	70	InvalidPrefix or InvalidAccessCode. The Ineffective Order SIT may apply. (e.g., "Your call cannot be completed as dialed. Please check the number and dial again.") [NoLECN]
0	1	0	0	0	1	1	1	71	OtherDialingIrregularity. The Ineffective Order SIT may apply. (e.g., "Your call cannot be completed as dialed. Please check the number and dial again.") [NoLECN]
0	1	0	1	0	0	0	0	80	VacantNumber or DisconnectedNumber. The Intercept SIT may apply. (e.g., "You have reached a number that has been disconnected or is no longer in service. If you feel you have reached this recording in error, please check the number and try again.") [NoLECN]
0	1	0	1	0	0	0	1	81	DenyTermination. The Intercept SIT may apply. Calls to the dialed number are denied by its service profile. (e.g., "The number you have dialed does not accept incoming calls.") [TIA/EIA-41]

Table 117 (continued)

0	1	0	1	0	0	1	0	82	SuspendedTermination. The called party has been temporarily disconnected. The Intercept SIT may apply. (e.g., "The number you have called has temporarily been disconnected.") [NoLECN]
0	1	0	1	0	0	1	1	83	ChangedNumber. The Intercept SIT may apply. (e.g., "The number you have reached (NPA) NXX-XXXX has been changed. The new number is (NPA) NXX-XXXX. Please make note of it.") [NoLECN]
0	1	0	1	0	1	0	0	84	InaccessibleSubscriber. The Ineffective Order SIT may apply. (e.g., "The customer you have called is not accessible. Please try your call again later.") [TIA/EIA-41]
0	1	0	1	0	1	0	1	85	DenyIncomingToll. A call to an MS, involving subscriber paid toll (e.g., Call Delivery, Call Forwarding, etc.), is not permitted by its service profile.) The Ineffective Order SIT may apply. (e.g., "The customer you have called is not accessible. Please try your call again later.")
0	1	0	1	0	1	1	1	86	RoamerAccessScreening. The subscriber called via a roamer port is either outside the roamer port calling area or is forwarded to a number outside the roamer port calling area. The Ineffective Order SIT may apply. (e.g., "You have reached a mobile subscriber that cannot be reached through this roamer port. Please try to dial the subscriber number directly.")
0	1	0	1	0	1	1	1	87	RefuseCall. The calling party has been refused by has permanent or temporary screening of incoming calls. The Intercept SIT may apply. (e.g., "The number you have dialed does not accept incoming calls.")
0	1	0	1	1	0	0	0	88	RedirectCall. (e.g., "Your call is being forwarded. Please wait.") [TIA/EIA-41]
0	1	0	1	1	0	0	1	89	NoPageResponse. (e.g., "Your call cannot be completed at this time. Please try your call again later.") [TIA/EIA-41]
0	1	0	1	1	0	1	0	90	NoAnswer. The called subscriber has not answered and the alerting has been discontinued. (e.g., "The customer you have called does not answer. Please try your call again later.")
0	1	1	0	0	0	0	0	96	RoamerIntercept. A subscriber has roamed into a service area requiring activation. (e.g., "If you are interested in using cellular service, call #.")
0	1	1	0	0	0	0	1	97	GeneralInformation. (e.g., "If you need assistance using your service features please call your service representative by dialing (*) 611.")
0	1	1	1	0	0	0	0	112	UnrecognizedFeatureCode. The subscriber dialed an unrecognized feature code. (e.g., "The feature code you have dialed is not valid. Please check the code and enter it again.") [TIA/EIA-664]
0	1	1	1	0	0	0	1	113	UnauthorizedFeatureCode. The subscriber dialed a recognized, but unauthorized, feature code. (e.g., "Your service does not include use of this feature. For more information please call your customer service representative by dialing (*) 611.") [TIA/EIA-664]

Table 117 (continued)

0	1	1	1	0	0	1	0	114	RestrictedFeatureCode. The subscriber dialed a feature code which is not available in his or her current service area. (e.g., "The feature code you have dialed is not available in your service area.")
0	1	1	1	0	0	1	1	115	InvalidModifierDigits. The subscriber attempted to activate a feature with invalid modifier digits. (e.g., "The modifier digits you have dialed is not valid. Please check the number and try again.")
0	1	1	1	0	1	0	0	116	SuccessfulFeatureRegistration. (e.g., "The feature you have selected has been registered.") [TIA/EIA-664]
0	1	1	1	0	1	0	1	117	SuccessfulFeatureDeRegistration. (e.g., "The feature you have selected has been de-registered.") [TIA/EIA-664]
0	1	1	1	0	1	1	0	118	SuccessfulFeatureActivation. (e.g., "The feature you have selected has been activated.") [TIA/EIA-664]
0	1	1	1	0	1	1	1	119	SuccessfulFeatureDeActivation. (e.g., "The feature you have selected has been de-activated.") [TIA/EIA-664]
0	1	1	1	1	0	0	0	120	InvalidForwardToNumber. (e.g., "The telephone number you have entered is not valid. Please try again.")
0	1	1	1	1	0	0	1	121	CourtesyCallWarning. The subscriber has dialed a feature code involving a courtesy call. (e.g., "Please wait while your call is forwarded.")
1	0	0	0	0	0	0	0	128	EnterPINSendPrompt. (e.g., "Please enter your PIN number and depress the SEND key.") [TIA/EIA-664]
1	0	0	0	0	0	0	1	129	EnterPINPrompt. (e.g., "Please enter your PIN.") [TIA/EIA-664]
1	0	0	0	0	0	1	0	130	ReEnterPINSendPrompt. (e.g., "Please re-enter your PIN number and depress the SEND key.") [TIA/EIA-664]
1	0	0	0	0	0	1	1	131	ReEnterPINPrompt. (e.g., "Please re-enter your PIN.") [TIA/EIA-664]
1	0	0	0	0	1	0	0	132	EnterOldPINSendPrompt. (e.g., "Please enter your old PIN number and depress the SEND key.") [TIA/EIA-664]
1	0	0	0	0	1	0	1	133	EnterOldPINPrompt. (e.g., "Please enter your old PIN.") [TIA/EIA-664]
1	0	0	0	0	1	1	0	134	EnterNewPINSendPrompt. (e.g., "Please enter your new PIN number and depress the SEND key.") [TIA/EIA-664]
1	0	0	0	0	1	1	1	135	EnterNewPINPrompt. (e.g., "Please enter your new PIN.") [TIA/EIA-664]
1	0	0	0	1	0	0	0	136	ReEnterNewPINSendPrompt. (e.g., "Please re-enter your new PIN number and depress the SEND key.") [TIA/EIA-664]
1	0	0	0	1	0	0	1	137	ReEnterNewPINPrompt. (e.g., "Please re-enter your new PIN.") [TIA/EIA-664]
1	0	0	0	1	0	1	0	138	EnterPasswordPrompt. (e.g., "Please enter your secret password number to access the called party.") [TIA/EIA-664]
1	0	0	0	1	0	1	1	139	EnterDirectoryNumberPrompt. (e.g., "Please enter your directory number.") [TIA/EIA-664]
1	0	0	0	1	1	0	0	140	ReEnterDirectoryNumberPrompt. (e.g., "Please re-enter your directory number.") [TIA/EIA-664]

1
2
3
4
5
6
7
8
9
10
11
12
13
14
15
16
17
18
19
20
21
22
23
24
25
26
27
28
29
30
31
32
33
34
35
36
37
38
39
40
41
42
43
44
45
46
47
48
49
50
51
52
53
54
55
56
57
58
59
60

Table 117 (concluded)

1 0 0 0 1 1 0 1	141	EnterFeatureCodePrompt. (e.g., "Please enter a feature code.") [TIA/EIA-664]
X X X X X X X X		Other values are reserved. Treat the same as value 0, .

Notes :

1. Its frequency and duration are different from Japanese specification. They are specified in JIGYOU-YOU-DENKI-TSUUSHIN-SETSUBI-KISOKU. *
2. It may not be used in JAPAN. *
3. These examples of announcement may not be used in TTC. *

6.5.2.6 AnnouncementList

The AnnouncementList (ANNLIST) parameter specifies a list of announcements to be given to a designated party. Announcements are played in order and in the preferred language of the affected party if possible.

Field	Value	Type	Reference	Notes
Identifier	AnnouncementList IMPLICIT SEQUENCE OF	M	6.5.1.2	
Length	variable	M	6.5.1.1	
Contents				
	AnnouncementCode	M	6.5.2.5	
	AnnouncementCode	O	6.5.2.5	a, b
	...			

Figure 13 AnnouncementList parameter

Notes:

- a. Optionally include additional AnnouncementCode parameters. The maximum number of AnnouncementCode parameters is dependent upon the two systems involved in the transaction and the intervening network.
- b. Ignore Class after playing the first occurrence of an AnnouncementCode with a *concurrent* class.

6.5.2.7 AuthenticationAlgorithmVersion

The AuthenticationAlgorithmVersion (AAV) parameter may be sent with messages that also contain the SharedSecretData parameter.

Field	Value	Type	Reference	Notes					
Identifier	AuthenticationAlgorithmVersion IMPLICIT OCTET STRING	M	6.5.1.2						
Length	variable octets	M	6.5.1.1						
Contents									
H	G	F	E	D	C	B	A	octet	Notes
Authentication Algorithm Version								1	
...								<i>n</i>	<i>a</i>

Figure 14 AuthenticationAlgorithmVersion parameter

Notes:

- a. Ignore extra octets, if received. Send only defined (or significant) octets.

Table 118 Authentication Algorithm Version value

Authentication Algorithm Version (octet 1)										
Bits	H	G	F	E	D	C	B	A	Value	Meaning
	0	0	0	0	0	0	0	0	0	} Value as used in the CAVE algorithm.
	1	1	1	1	1	1	1	1	255	
	1	1	0	0	0	1	1	1	199	The default value if this parameter is not received from the AC.

6.5.2.8 AuthenticationCapability

The AuthenticationCapability (AUTHCAP) parameter indicates whether an MS shall or shall not be authenticated.

Field	Value	Type	Reference	Notes					
Identifier	AuthenticationCapability IMPLICIT OCTET STRING	M	6.5.1.2						
Length	variable octets	M	6.5.1.1						
Contents									
H	G	F	E	D	C	B	A	octet	Notes
Authentication Capability								1	
...								<i>n</i>	<i>a</i>

Figure 15 AuthenticationCapability parameter

Notes:

- a. Ignore extra octets, if received. Send only defined (or significant) octets.

Table 119 AuthenticationCapability value

<i>Authentication Capability (octet 1)</i>										
Bits	H	G	F	E	D	C	B	A	Value	Meaning
	0	0	0	0	0	0	0	0	0	Not used.
	0	0	0	0	0	0	0	1	1	No authentication required.
	0	0	0	0	0	0	1	0	2	Authentication required.
	0	0	0	0	0	0	1	1	3	} Reserved. Treat the same as value 1, <i>No authentication required.</i>
			...						through 95	
	0	1	0	1	1	1	1	1	96	} Reserved for <i>TIA/EIA-41</i> protocol extension. If unknown, treat the same as value 1, <i>No authentication required.</i>
			...						through 127	
	1	0	0	0	0	0	0	0	128	} Reserved. Treat the same as value 2, <i>Authentication required.</i>
			...						through 223	
	1	1	0	1	1	1	1	1	224	} Reserved for <i>TIA/EIA-41</i> protocol extension. If unknown, treat the same as value 2, <i>Authentication required.</i>
			...						through 255	

6.5.2.9 AuthenticationData

The AuthenticationData (AUTHDATA) parameter contains the 24-bit authentication data used as input to CAVE for call origination. AUTHDATA is derived from the information sent by the MS (e.g., last six digits or characters).

Field	Value	Type	Reference	Notes					
Identifier	AuthenticationData IMPLICIT OCTET STRING	M	6.5.1.2						
Length	3 octets	M	6.5.1.1						
Contents									
H	G	F	E	D	C	B	A	octet	Notes
AUTHDATA								1	a
								2	
								3	
								MSB	
								LSB	

Figure 16 AuthenticationData parameter

Notes:

- a. See appropriate air interface standards for encoding.

6.5.2.10 AuthenticationResponse

The AuthenticationResponse (AUTHR) parameter contains the 18-bit authentication response generated by an MS when accessing the system (e.g., call origination, page response or autonomous registration). It is computed by CAVE using the SSD of the MS and a Random Number (RAND) chosen by the MSC-V.

Field	Value	Type	Reference	Notes					
Identifier	AuthenticationResponse IMPLICIT OCTET STRING	M	6.5.1.2						
Length	3 octets	M	6.5.1.1						
Contents									
H	G	F	E	D	C	B	A	octet	Notes
Reserved						MSB		1	
Authentication Response						LSB		2	
								3	a

Figure 17 AuthenticationResponse parameter

Notes:

- a. Reserved bits shall be ignored on receipt and set to zero on sending.

6.5.2.11 AuthenticationResponseBaseStation

The AuthenticationResponseBaseStation (AUTHBS) parameter contains the 18-bit response to a Base Station Challenge Order, computed by CAVE using the new SSD of the MS and a Random Number (RANDBS) chosen by the MS.

Field	Value	Type	Reference	Notes					
Identifier	AuthenticationResponse-BaseStation IMPLICIT OCTET STRING	M	6.5.1.2						
Length	3 octets	M	6.5.1.1						
Contents									
H	G	F	E	D	C	B	A	octet	Notes
Reserved						MSB		1	
AuthenticationResponseBaseStation						LSB		2	
								3	a

Figure 18 AuthenticationResponseBaseStation parameter

Notes:

- a. Reserved bits shall be ignored on receipt and set to zero on sending.

6.5.2.12 AuthenticationResponseUniqueChallenge

The AuthenticationResponseUniqueChallenge (AUTHU) parameter contains the MS's 18-bit response to a Unique Challenge Order, computed by CAVE using the SSD of the MS and a Random Number (RANDU).

Field	Value	Type	Reference	Notes					
Identifier	AuthenticationResponse-UniqueChallenge IMPLICIT OCTET STRING	R	6.5.1.2						
Length	3 octets	M	6.5.1.1						
Contents									
H	G	F	E	D	C	B	A	octet	Notes
Reserved						MSB		1	
AuthenticationResponseUniqueChallenge						LSB		2	
								3	a

Figure 19 AuthenticationResponseUniqueChallenge parameter

Notes:

- a. Reserved bits shall be ignored on receipt and set to zero on sending.

6.5.2.13 AuthorizationDenied

The AuthorizationDenied (AUTHDEN) parameter is used to indicate that the MS is not authorized.

Field	Value	Type	Reference	Notes					
Identifier	AuthorizationDenied IMPLICIT Unsigned Enumerated	M	6.5.1.2						
Length	1 octet	M	6.5.1.1						
Contents									
H	G	F	E	D	C	B	A	octet	Notes
AuthorizationDenied Reason								1	

Figure 20 AuthorizationDenied parameter

Table 120 AuthorizationDenied Reason value

AuthorizationDenied Reason (octet 1)										
Bits	H	G	F	E	D	C	B	A	Value	Meaning
	0	0	0	0	0	0	0	0	0	Not used.
	0	0	0	0	0	0	0	1	1	Delinquent account.
	0	0	0	0	0	0	1	0	2	Invalid serial number.
	0	0	0	0	0	1	1	1	3	Stolen unit.
	0	0	0	0	0	1	0	0	4	Duplicate unit.
	0	0	0	0	0	1	0	1	5	Unassigned directory number.
	0	0	0	0	0	1	1	0	6	Unspecified.
	0	0	0	0	0	1	1	1	7	Multiple access.
	0	0	0	0	1	0	0	0	8	Not Authorized for the MSC.
	0	0	0	0	1	0	0	1	9	Missing authentication parameters.
	0	0	0	0	1	0	1	0	10	TerminalType mismatch.
	0	0	0	0	1	0	1	1	11	} Reserved. Treat the same as value 6, <i>Unspecified.</i>
				...					through 223	
	1	1	0	1	1	1	1	1	224	} Reserved for TIA/EIA-41 protocol extension. If unknown, treat the same as value 6, <i>Unspecified.</i>
	1	1	1	0	0	0	0	0	through 255	

6.5.2.14 AuthorizationPeriod

The AuthorizationPeriod (AUTHPER) parameter is used to confirm authorization and specify the authorization period. After the authorization period has elapsed, the visited system must obtain authorization from the home system before providing service to the MS, except for Call Delivery which carries an implicit single call authorization.

Field	Value	Type	Reference	Notes					
Identifier	AuthorizationPeriod IMPLICIT OCTET STRING	M	6.5.1.2						
Length	2 octets	M	6.5.1.1						
Contents									
H	G	F	E	D	C	B	A	octet	Notes
Period								1	
Value								2	

Figure 21 AuthorizationPeriod parameter

Table 121 AuthorizationPeriod value

<i>Period (octet 1)</i>										
Bits	H	G	F	E	D	C	B	A	Value	Meaning
	0	0	0	0	0	0	0	0	0	Not used.
	0	0	0	0	0	0	0	1	1	Per Call.
	0	0	0	0	0	0	1	0	2	Hours.
	0	0	0	0	0	0	1	1	3	Days.
	0	0	0	0	0	1	0	0	4	Weeks.
	0	0	0	0	0	1	0	1	5	Per Agreement.
	0	0	0	0	0	1	1	0	6	Indefinite (i.e., authorized until canceled or de-registered).
	0	0	0	0	0	1	1	1	7	Number of calls.
	0	0	0	0	1	0	0	0	8	} Reserved. Treat the same as value 1, <i>Per Call</i> .
	1	1	0	1	1	1	1	1	through 223	
	1	1	1	0	0	0	0	0	224	} Reserved for <i>TIA/EIA-41</i> protocol extension. If unknown, treat the same as value 1, <i>Per Call</i> .
	1	1	1	1	1	1	1	1	through 255	
<i>Value (octet 2)</i>										
Bits	H	G	F	E	D	C	B	A	Value	Meaning
	0	0	0	0	0	0	0	0	0	} Number of hours, days, weeks, or number of calls (as per Period). If Period indicates anything else, the Value is set to zero on sending and ignored on receipt.
	1	1	1	1	1	1	1	1	through 255	

6.5.2.15 AvailabilityType

The AvailabilityType (AVTYP) parameter indicates that an MS is unavailable for the purposes of normal Call Delivery. The MS is operating in a mode where it may be intentionally inaccessible for periods of time (e.g., slotted mode, paging frame class, or sleep mode).

Field	Value	Type	Reference	Notes					
Identifier	AvailabilityType IMPLICIT OCTET STRING	M	6.5.1.2						
Length	variable octets	M	6.5.1.1						
Contents									
H	G	F	E	D	C	B	A	octet	Notes
AvailabilityType								1	
...								<i>n</i>	<i>a</i>

Figure 22 AvailabilityType parameter

Notes:

- a Ignore extra octets, if received. Send only defined (or significant) octets.

Table 122 AvailabilityType value

<i>AvailabilityType (octet 1)</i>										
Bits	H	G	F	E	D	C	B	A	Value	Meaning
	0	0	0	0	0	0	0	0	0	Not used.
	0	0	0	0	0	0	0	1	1	Unspecified MS inactivity typr.
	0	0	0	0	0	0	1	0	2	} Reserved. Treat the same as value 1, <i>Unspecified.</i>
			...						through 223	
	1	1	0	1	1	1	1	1	224	} Reserved for <i>TIA/EIA-41</i> protocol extension . If unknown, treat the same as value 1, <i>Unspecified.</i>
	1	1	1	0	0	0	0	0	through 255	
	1	1	1	1	1	1	1	1	255	

6.5.2.16 BillingID

The BillingID (BILLID) parameter is initially assigned at the Anchor MSC for originating and terminating calls involving radio contact. The BillingID is transferred, as required, to each system involved in an intersystem operation. This ID is primarily intended for billing record correlation, but may be used for other purposes such as identifying the Anchor MSC, etc.

A BillingID is also assigned at the Originating MSC for incoming calls.

Field	Value	Type	Reference	Notes					
Identifier	BillingID IMPLICIT OCTET STRING	M	6.5.1.2						
Length	7 octets	M	6.5.1.1						
Contents									
H	G	F	E	D	C	B	A	octet	Notes
MSB								1	a
Anchor or Originating MarketID							LSB	2	
Anchor or Originating Switch Number								3	a
MSB								4	b
ID Number							LSB	5	
							6		
Segment Counter								7	

Figure 23 BillingID parameter

Notes:

- a. Refer to the MSCID parameter (see 6.5.2.82) for the definition of these fields.
- b. is a unique number assigned by the functional entity identified in the MarketID and Switch Number fields (see *DMH*).

Table 123 BillingID value

<i>(octet 7)</i>										
Bits	H	G	F	E	D	C	B	A	Value	Meaning
	0	0	0	0	0	0	0	0	0	} Number of call segments (see <i>DMH</i>).
	0	1	1	1	1	1	1	1	127	
	1	X	X	X	X	X	X	X	-	Bit H is intended for recording use following call disconnect and will always be 0 in <i>TIA/EIA-41</i> messages, except value 255, <i>Unspecified</i> .
	1	1	1	1	1	1	1	1	255	Unspecified. The number of segments is unknown.

6.5.2.17 BorderCellAccess

The BorderCellAccess (BORDACC) parameter is used to indicate a system access in a border cell.

Field	Value	Type	Reference	Notes					
Identifier	BorderCellAccess IMPLICIT Unsigned Enumerated	M	6.5.1.2						
Length	1 octet	M	6.5.1.1						
Contents									
H	G	F	E	D	C	B	A	octet	Notes
BorderCellAccess Indication								1	

Figure 24 BorderCellAccess parameter

Table 124 BorderCellAccess value

<i>BorderCellAccess Indication (octet 1)</i>										
Bits	H	G	F	E	D	C	B	A	Value	Meaning
	0	0	0	0	0	0	0	0	0	Not used.
	0	0	0	0	0	0	0	1	1	Border Cell Access.
	0	0	0	0	0	0	1	0	2	} Reserved. Treat the same as value 1, <i>Border Cell Access.</i>
				...					through 223	
	1	1	0	1	1	1	1	1	224	} Reserved for <i>TIA/EIA-41</i> protocol extension. If unknown, treat the same as value 1, <i>Border Cell Access.</i>
	1	1	1	0	0	0	0	0	through 255	

6.5.2.18 CallHistoryCount

The CallHistoryCount (COUNT) parameter contains a modulo 64 event counter maintained by the MS, AC and optionally the VLR, that is used for clone detection. The events that result in incrementing the counter are defined by local administrative procedures at the AC and optionally at the VLR, and may include initial registration in a new Serving MSC, call origination, page response or periodically.

Field	Value	Type	Reference	Notes					
Identifier	CallHistoryCount IMPLICIT Unsigned Integer (0..63)	M	6.5.1.2						
Length	1 octet	M	6.5.1.1						
Contents									
H	G	F	E	D	C	B	A	octet	Notes
COUNT Event Counter								1	

Figure 25 CallHistoryCount parameter

6.5.2.19 CallHistoryCountExpected

The CallHistoryCountExpected (COUNTEx) parameter contains a modulo 64 event counter which was expected from the MS. The value received from the MS is sent in the CallHistoryCount parameter.

Field	Value	Type	Reference	Notes					
Identifier	CallHistoryCountExpected IMPLICIT Unsigned Integer (0..63)	M	6.5.1.2						
Length	1 octet	M	6.5.1.1						
Contents									
H	G	F	E	D	C	B	A	octet	Notes
COUNT Event Counter								1	

Figure 26 CallHistoryCountExpected parameter

6.5.2.20 CallingFeaturesIndicator

The CallingFeaturesIndicator (CFI) parameter defines the authorization and activity states of the MS's features.

The minimum length of this parameter is 2 octets.

Field	Value	Type	Reference	Notes					
Identifier	CallingFeaturesIndicator IMPLICIT OCTET STRING	M	6.5.1.2						
Length	variable octets	M	6.5.1.1						
Contents									
H	G	F	E	D	C	B	A	octet	Notes
CW-FA		CFNA-FA		CFB-FA		CFU-FA		1	a
CT-FA		VP-FA		CD-FA		3WC-FA		2	a
CNIROver-FA		CNIR-FA		CNIP2-FA		CNIP1-FA		3	a
Reserved						PCW-FA		4	a, b
...								<i>n</i>	c

Figure 27 CallingFeaturesIndicator parameter

Notes:

- a. CFU-FA, CFB-FA, etc., denotes the FeatureActivity status for the designated feature, where the FeatureActivity encoding is defined in Table 125.
- **CFU-FA** = Call Forwarding–Unconditional FeatureActivity.
 - **CFB-FA** = Call Forwarding–Busy FeatureActivity.
 - **CFNA-FA** = Call Forwarding–No Answer FeatureActivity.
 - **CW-FA** = Call Waiting: FeatureActivity.
 - **3WC-FA** = Three-Way Calling FeatureActivity.
 - **CD-FA** = Call Delivery: FeatureActivity (not interpreted on reception by *IS-41-C* or later).
 - **VP-FA** = Voice Privacy FeatureActivity.
 - **CT-FA** = Call Transfer: FeatureActivity.
 - **CNIP1-FA** = One number (network-provided only) Calling Number Identification Presentation: FeatureActivity. CNIP2-FA takes precedence over CNIP1-FA.
 - **CNIP2-FA** = Two number (network-provided and user-provided) Calling Number Identification Presentation: FeatureActivity. CNIP2-FA takes precedence over CNIP1-FA.
 - **CNIR-FA** = Calling Number Identification Restriction: FeatureActivity. An *Authorized and Activated* value for CNIR-FA indicates that Calling Number Identification Presentation is restricted.
 - **CNIROver-FA** = Calling Number Identification Restriction Override FeatureActivity. An *Authorized and activated* value for CNIROver indicates that Calling Number Identification Restriction is overridden.
 - **PCW-FA** = Priority Call Waiting FeatureActivity.
- b. Reserved bits shall be ignored on receipt and set to zero on sending.
- c. Ignore extra octets, if received. Send only defined (or significant) octets.

Table 125 CallingFeaturesIndicator value

<i>FeatureActivity</i>				
Bits	H	G	Value	Meaning
	or F	E		
	or D	C		
	or B	A		
	0	0	0	Not used.
	0	1	1	Not Authorized.
	1	0	2	Authorized but de-activated.
	1	1	3	Authorized and activated.

6.5.2.21 CallingPartyNumberDigits1

The CallingPartyNumberDigits1 (CPNDGTS1) parameter carries the network-provided calling party number information, in BCD format.

Field	Value	Type	Reference	Notes					
Identifier	CallingPartyNumberDigits1 IMPLICIT DigitsType	M	6.5.1.2	a					
Length	variable octets	M	6.5.1.1						
Contents									
H	G	F	E	D	C	B	A	octet	Notes
Type of Digits								1	b
Nature of Number								2	c
Numbering Plan				Encoding				3	d, e
Number of Digits								4	f
2 nd BCD Digit				1 st BCD Digit				5	
4 th BCD Digit				3 rd BCD Digit				6	
...				
n^{th} BCD Digit				$n-1^{\text{st}}$ BCD Digit				m	

Figure 28 CallingPartyNumberDigits1 parameter for BCD digits

Notes:

- a. Refer to the DigitsType parameter type (see 6.5.3.2) for notes and field encoding.
- b. The Type of Digits field is set to *Calling Party Number*.
- c. The Nature of Number field is set as applicable.
- d. The Numbering Plan field is set to *Telephony Numbering*.
- e. The Encoding field is set to *BCD*.
- f. The Number of Digits is between 0 and at least 15.

6.5.2.22 CallingPartyNumberDigits2

The CallingPartyNumberDigits2 (CPNDGTS2) parameter carries the user-provided calling party number information, in BCD format.

Field	Value	Type	Reference	Notes					
Identifier	CallingPartyNumberDigits2 IMPLICIT DigitsType	M	6.5.1.2	a					
Length	variable octets	M	6.5.1.1						
Contents									
H	G	F	E	D	C	B	A	octet	Notes
Type of Digits								1	b
Nature of Number								2	c
Numbering Plan				Encoding				3	d, e
Number of Digits								4	f
2 nd BCD Digit				1 st BCD Digit				5	
4 th BCD Digit				3 rd BCD Digit				6	
...				
n^{th} BCD Digit				$n-1^{\text{st}}$ BCD Digit				m	

Figure 29 CallingPartyNumberDigits2 parameter for BCD digits

Notes:

- a. Refer to the DigitsType parameter type (see 6.5.3.2) for notes and field encoding.
- b. The Type of Digits field is set to *Calling Party Number*.
- c. The Nature of Number field is set as applicable.
- d. The Numbering Plan field is set to *Telephony Numbering*.
- e. The Encoding field is set to *BCD*.
- f. The Number of Digits is between 0 and at least 15.

6.5.2.23 CallingPartyNumberString1

The CallingPartyNumberString1 (CPNSTRG1) parameter carries the network-provided identification of the calling party, in IA5 format.

Field	Value	Type	Reference	Notes					
Identifier	CallingPartyNumberString1 IMPLICIT DigitsType	M	6.5.1.2	a					
Length	variable octets	M	6.5.1.1						
Contents									
H	G	F	E	D	C	B	A	octet	Notes
Type of Digits								1	b
Nature of Number								2	c
Numbering Plan				Encoding				3	d, e
Number of Digits								4	f
1 st Character								5	
2 nd Character								6	
...								...	
Last Character								<i>n</i>	

Figure 30 CallingPartyNumberString1 parameter for IA5 digits

Notes:

- a. Refer to the DigitsType parameter type (see 6.5.3.2) for notes and field encoding.
- b. The Type of Digits field is set to *Calling Party Number*.
- c. The Nature of Number field is set as applicable.
- d. The Numbering Plan field is set to *Telephony Numbering*.
- e. The Encoding field is set to *IA5*.
- f. The Number of Digits is between 0 and at least 15.

6.5.2.24 CallingPartyNumberString2

The CallingPartyNumberString2 (CPNSTRG2) parameter carries the user-provided identification of the calling party, in IA5 format.

Field	Value	Type	Reference	Notes					
Identifier	CallingPartyNumberString2 IMPLICIT DigitsType	M	6.5.1.2	a					
Length	variable octets	M	6.5.1.1						
Contents									
H	G	F	E	D	C	B	A	octet	Notes
Type of Digits								1	b
Nature of Number								2	c
Numbering Plan				Encoding				3	d, e
Number of Digits								4	f
1 st Character								5	
2 nd Character								6	
...								...	
Last Character								<i>n</i>	

Figure 31 CallingPartyNumberString2 parameter for IA5 digits

Notes:

- a. Refer to the DigitsType parameter type (see 6.5.3.2) for notes and field encoding.
- b. The Type of Digits field is set to *Calling Party Number*.
- c. The Nature of Number field is set as applicable.
- d. The Numbering Plan field is set to *Telephony Numbering*.
- e. The Encoding field is set to *IA5*.
- f. The Number of Digits is between 0 and at least 15.

6.5.2.25 CallingPartySubaddress

The CallingPartySubaddress (CPSUB) parameter identifies the subaddress of the calling party of a call.

Field	Value	Type	Reference	Notes					
Identifier	CallingPartySubaddress IMPLICIT Subaddress	M	6.5.1.2	a					
Length	variable octets	M	6.5.1.1						
Contents									
H	G	F	E	D	C	B	A	octet	Notes
1	Type of Subaddress			O/E	Reserved			1	
Subaddress ...								2	
								3	
								...	
								<i>n</i>	

Figure 32 CallingPartySubaddress parameter

Notes:

- a. Refer to the Subaddress parameter type (see 6.5.3.12) for notes and field encoding.

6.5.2.26 CancellationDenied

The CancellationDenied (CANDEN) parameter is used to indicate that either:

- a. the MS associated with this CancellationDenied has simultaneously accessed multiple MSCs, and the VLR which sent this parameter considers itself to be the best serving system, or
- b. the addressed MS is currently involved in a call or service request.

Field	Value	Type	Reference	Notes					
Identifier	CancellationDenied IMPLICIT Unsigned Enumerated	M	6.5.1.2						
Length	1 octet	M	6.5.1.1						
Contents									
H	G	F	E	D	C	B	A	octet	Notes
CancellationDenied Indication								1	

Figure 33 CancellationDenied parameter

Table 126 CancellationDenied value

<i>CancellationDenied Indication (octet 1)</i>										
Bits	H	G	F	E	D	C	B	A	Value	Meaning
	0	0	0	0	0	0	0	0	0	Not used.
	0	0	0	0	0	0	0	1	1	Multiple Access (i.e., VLR has detected a multiple access situation and considers itself to be the best serving system).
	0	0	0	0	0	0	1	0	2	
	0	0	0	0	0	0	1	1	3	} Reserved. Treat the same as value 1, <i>Multiple Access</i> .
				...					through 223	
	1	1	0	1	1	1	1	1	223	
	1	1	1	0	0	0	0	0	224	} Reserved for TIA/EIA-41 protocol extension. If unknown, treat the same as value 1, <i>Multiple Access</i> .
				...					through 255	
	1	1	1	1	1	1	1	1	255	

6.5.2.27 CancellationType

The CancellationType (CANTYP) parameter indicates the handling of the call or service interruption caused by the receipt of a RegistrationCancellation INVOKE component.

Field	Value	Type	Reference	Notes					
Identifier	CancellationType IMPLICIT OCTET STRING	M	6.5.1.2						
Length	variable octets	M	6.5.1.1						
Contents									
H	G	F	E	D	C	B	A	octet	Notes
Cancellation Type								1	
...								<i>n</i>	<i>a</i>

Figure 34 CancellationType parameter

Notes:

- a. Ignore extra octets, if received. Send only defined (or significant) octets.

Table 127 CancellationType value

<i>Cancellation Type(octet 1)</i>										
Bits	H	G	F	E	D	C	B	A	Value	Meaning
	0	0	0	0	0	0	0	0	0	Not used.
	0	0	0	0	0	0	0	1	1	ServingSystemOption. The serving system may discontinue a call or service in progress at its option.
	0	0	0	0	0	0	1	0	2	ReportInCall. The serving system shall continue to provide service when a call or service is in progress and just report its incidence.
	0	0	0	0	0	0	1	1	3	Discontinue. The serving system shall discontinue any call or service in progress, regardless of the MS's qualification, profile or authentication.
	0	0	0	0	0	1	0	0	4	} Reserved. Treat the same as value 1, <i>ServingSystemOption</i> .
	1	1	0	1	1	1	1	1	through 223	
	1	1	1	0	0	0	0	0	224	} Reserved for <i>TIA/EIA-41</i> protocol extension. If unknown, treat the same as value 1, <i>ServingSystemOption</i> .
	1	1	1	1	1	1	1	1	through 255	

6.5.2.28 CarrierDigits

The CarrierDigits (CARDGTS) parameter specifies the preferred interexchange carrier for the call. CarrierDigits is currently only specified for national usage.

Field	Value	Type	Reference	Notes					
Identifier	CarrierDigits IMPLICIT DigitsType	M	6.5.1.2	a					
Length	variable octets	M	6.5.1.1						
Contents									
H	G	F	E	D	C	B	A	octet	Notes
Type of Digits								1	b
Nature of Number								2	c
Numbering Plan				Encoding				3	d, e
Number of Digits								4	f
2 nd BCD Digit				1 st BCD Digit				5	
4 th BCD Digit				3 rd BCD Digit				6	
...				
n^{th} BCD Digit				$n-1^{\text{st}}$ BCD Digit				m	

Figure 35 CarrierDigits parameter for BCD digits

Notes:

- a. Refer to the DigitsType parameter type (see 6.5.3.2) for notes and field encoding.
- b. The Type of Digits field is set to *Carrier*.
- c. The Nature of Number field is set to *National*, other subfields are ignored on receipt.
- d. The Numbering Plan field is set to *Telephony Numbering*.
- e. The Encoding field is set to *BCD*.
- f. The Number of Digits is between 3 and 5.

6.5.2.29 CDMACallMode

The CDMACallMode (CDMAMODE) parameter identifies certain characteristics of a multi-mode CDMA and NAMPS MS.

Field	Value	Type	Reference	Notes					
Identifier	CDMACallMode IMPLICIT OCTET STRING	M	6.5.1.2						
Length	variable octets	M	6.5.1.1						
Contents									
H	G	F	E	D	C	B	A	octet	Notes
Reserved					Call Mode			1	a
...								<i>n</i>	b

Figure 36 CDMACallMode parameter

Notes:

- a. Reserved bits shall be ignored on receipt and set to zero on sending.
- b. Ignore extra octets, if received. Send only defined (or significant) octets.

Table 128 CDMACallMode value

<i>Call Mode (octet 1, bits A-C)</i>										
Bits	H	G	F	E	D	C	B	A	Value	Meaning
								0	-	CDMA channel not acceptable.
								1	-	CDMA channel acceptable.
								0	-	AMPS channel not acceptable.
								1	-	AMPS channel acceptable.
					0				-	NAMPS channel not acceptable.
					1				-	NAMPS channel acceptable.

6.5.2.30 CDMAChannelData

The CDMAChannelData (CDMADATA) parameter contains the CDMA Channel Number field, the Frame Offset field and a Long Code Mask field associated with the CDMA Traffic channel in use. The CDMA Channel Number is an 11-bit number corresponding to the CDMA frequency assignment. This number specifies the channel number for the CDMA Channel center frequency (see *CDMA* for details).

The Frame Offset is a 4-bit binary number that contains the time skew of Traffic Channel frames in units of 1.25 ms. The maximum frame offset is 18.75 ms which is 15 times 1.25 ms. The valid values in the Frame Offset field are 0 through 15.

The Long Code Mask is a 42-bit binary number that contains the long code mask in use at the Serving MSC. The Long Code Mask creates a unique identity of the MS's long code which is a Pseudo Random Number sequence with period of $2^{42}-1$ that is used for scrambling on the Forward CDMA Channel and spreading on the Reverse CDMA Channel.

The Band Class indicates the frequency band to which the MS is being redirected.

The minimum length of this parameter is 8 octets.

Field	Value	Type	Reference	Notes					
Identifier	CDMAChannelData IMPLICIT OCTET STRING	M	6.5.1.2						
Length	variable octets	M	6.5.1.1						
Contents									
H	G	F	E	D	C	B	A	octet	Notes
Res'd	Frame Offset				MSB			1	a, b
CDMA Channel Number								2	
Res'd	Band Class				MSB			3	a, b, c
Long Code Mask								...	
								7	
								8	
...								n	d

Figure 37 CDMAChannelData parameter

Notes:

- See *CDMA* for definitions of these fields.
- Reserved (Res'd) bits shall be ignored on receipt and set to zero on sending.
- The bit layout is the same as that of Band Class Value Assignments defined in *TSB58*.
- Ignore extra octets, if received. Send only defined (or significant) octets.

Table 129 CDMAChannelData value

<i>Band Class (octet 3, bits C-G)</i>										
Bits	H	G	F	E	D	C	B	A	Value	Meaning
		0	0	0	0	0			0	800 MHz Cellular System.
		0	0	0	0	1			1	} Reserved. Treat the same as value 0.
				...					through	
		1	1	1	1	1			31	

6.5.2.31 CDMACodeChannel

The CDMACodeChannel (CDMACHAN) parameter specifies the code channel in a Forward CDMA Channel. A Forward CDMA Channel contains 64 code channels. Code channel 0 is assigned to the Pilot Channel. Code channel 1 through 7 may be assigned to either the Paging Channels or Traffic Channels. Code channel 32 may be assigned to either a Synchronization Channel or a Traffic Channel. The remaining code channels may be assigned to the Traffic Channels.

Field	Value	Type	Reference	Notes					
Identifier	CDMACodeChannel IMPLICIT OCTET STRING	M	6.5.1.2						
Length	variable octets	M	6.5.1.1						
Contents									
H	G	F	E	D	C	B	A	octet	Notes
Reserved								1	a, b
...								<i>n</i>	c

Figure 38 CDMACodeChannel parameter

Notes:

- a. See *CDMA* for the definition of this field.
- b. Reserved bits shall be ignored on receipt and set to zero on sending.
- c. Ignore extra octets, if received. Send only defined (or significant) octets.

6.5.2.32 CDMACodeChannelInformation

The CDMACodeChannelInformation (CDMACHINFO) parameter specifies CDMA code channel information which is used in the handoff process.

Field	Value	Type	Reference	Notes
Identifier	CDMACodeChannelInformation IMPLICIT SEQUENCE	M	6.5.1.2	
Length	variable	M	6.5.1.1	
Contents				
TargetCellID		M	6.5.2.148	
CDMACodeChannel		M	6.5.2.31	
...				a

Figure 39 CDMACodeChannelInformation parameter

Notes:

- a. Ignore unexpected parameters, if received.

6.5.2.33 CDMACodeChannelList

The CDMACodeChannelList (CDMACHLIST) parameter specifies CDMA code channel information which is used in the handoff process.

Field	Value	Type	Reference	Notes
Identifier	CDMACodeChannelList IMPLICIT SEQUENCE OF	M	6.5.1.2	
Length	variable	M	6.5.1.1	
Contents				
	CDMACodeChannelInformation	M	6.5.2.32	
	CDMACodeChannelInformation	O	6.5.2.32	a
	...			

Figure 40 CDMACodeChannelList parameter

Notes:

- a. Optionally include additional CDMACodeChannelInformation parameters.

6.5.2.34 CDMA MobileProtocolRevision

This parameter was named MOB_P_REV prior to this revision of the Interim Standard.

The CDMA MobileProtocolRevision (CDMAMPR) parameter contains the CDMA Mobile Protocol Revision number of the MS.

Field	Value	Type	Reference	Notes					
Identifier	CDMA MobileProtocolRevision IMPLICIT OCTET STRING	M	6.5.1.2						
Length	variable octets	M	6.5.1.1						
Contents									
H	G	F	E	D	C	B	A	octet	Notes
Revision Number								1	a
...								<i>n</i>	b

Figure 41 CDMA MobileProtocolRevision parameter

Notes:

- a. See *CDMA MOB_P_REV* for the definition of this field.
- b. Ignore extra octets, if received. Send only defined (or significant) octets.

6.5.2.35 CDMAPilotStrength

The CDMAPilotStrength (CDMAPILOT) parameter indicates the signal strength of a CDMA Pilot Channel transmitted by a base station and measured by an MS. The pilot strength is the signal to noise ratio E_c/I_0 where E_c is the pilot energy per Pseudonoise (PN) chip (i.e., 813.802 ns), summed over various pilot multipath components, and I_0 is the total received power (noise plus signal) in CDMA bandwidth normalized to 1 Hz. This parameter is set to (-20) times \log_{10} (Pilot Strength) and rounded down to the smallest integer. The valid values are 0 through 63.

Field	Value	Type	Reference	Notes					
Identifier	CDMAPilotStrength IMPLICIT OCTET STRING	M	6.5.1.2						
Length	1 octet	M	6.5.1.1						
Contents									
H	G	F	E	D	C	B	A	octet	Notes
Reserved		CDMA Pilot Strength						1	a, b

Figure 42 CDMAPilotStrength parameter

Notes:

- a. See *CDMA PILOT_STRENGTH* for the definition of this field.
- b. Reserved bits shall be ignored on receipt and set to zero on sending.

6.5.2.36 CDMAPrivateLongCodeMask

This parameter was named PrivateLongCodeMask prior to this revision of the Interim Standard.

The CDMAPrivateLongCodeMask (CDMAPLCM) parameter contains the 42-bit private long code mask.

Field	Value	Type	Reference	Notes					
Identifier	CDMAPrivateLongCodeMask IMPLICIT OCTET STRING	M	6.5.1.2						
Length	6 octets	M	6.5.1.1						
Contents									
H	G	F	E	D	C	B	A	octet	Notes
Reserved						MSB	A	1	a, b
CDMA Private Long Code Mask								5	
								6	
								LSB	

Figure 43 CDMAPrivateLongCodeMask parameter

Notes:

- a. See *CDMA* for the definition of this field.
- b. Reserved bits shall be ignored on receipt and set to zero on sending.

6.5.2.37 CDMASearchWindow

This parameter was named SearchWindow prior to this revision of the Interim Standard.

The CDMASearchWindow (CDMASWIN) parameter specifies the number of pseudonoise (PN) chips that a CDMA MS should use to search for usable multipath components (i.e., multipath components that the MS can use for demodulation of the associated Forward Traffic Channel) of the pilots in the Active Set and the Candidate Set. The valid values are 0 through 15.

Field	Value	Type	Reference	Notes					
Identifier	CDMASearchWindow IMPLICIT OCTET STRING	M	6.5.1.2						
Length	1 octet	M	6.5.1.1						
Contents									
H	G	F	E	D	C	B	A	octet	Notes
Reserved				CDMA Search Window				1	a

Figure 44 CDMASearchWindow parameter

Notes:

- a. See *CDMA SRCH_WIN_A* for the definition of this field.
- b. Reserved bits shall be ignored on receipt and set to zero on sending.

6.5.2.38 CDMA-servingOneWayDelay

This parameter was named ServingOneWayDelay prior to this revision of the Interim Standard.

The CDMA-servingOneWayDelay (CDMASOWD) parameter specifies the estimated one-way delay from the MS to a serving base station. The estimated delay can be converted to the estimated distance. The estimate can be used to minimize the search and acquisition times for the MS. The estimated one way delay between the MS and the associated base station is specified in units of 100 ns. The valid values are 0 through 65535.

Field	Value	Type	Reference	Notes						
Identifier	CDMA-servingOneWayDelay IMPLICIT OCTET STRING	M	6.5.1.2							
Length	2 octets	M	6.5.1.1							
Contents										
H	G	F	E	D	C	B	A	octet	Notes	
MSB							CDMA Serving One Way Delay		1	
							LSB		2	

Figure 45 CDMA-servingOneWayDelay parameter

6.5.2.39 CDMASignalQuality

The CDMASignalQuality (CDMAQUAL) parameter indicates the signal quality from the MS as measured by a base station. The signal quality is the signal to noise ratio E_b/N_0 where E_b is the energy per bit and N_0 is the total received noise power in the CDMA bandwidth normalized to 1 Hz. Signal Quality shall be computed by adding together the individual E_b/N_0 values from each multipath component. The CDMASignalQuality parameter is set to (20) times \log_{10} (Signal Quality) and rounded down to the smallest integer. The valid values are 0 through 63.

Field	Value	Type	Reference	Notes					
Identifier	CDMASignalQuality IMPLICIT OCTET STRING	M	6.5.1.2						
Length	1 octet	M	6.5.1.1						
Contents									
H	G	F	E	D	C	B	A	octet	Notes
Reserved		CDMA Signal Quality						1	a, b

Figure 46 CDMASignalQuality parameter

Notes:

- a. See *CDMA* for the definition of this field.
- b. Reserved bits shall be ignored on receipt and set to zero on sending.

6.5.2.40 CDMASlotCycleIndex

The CDMASlotCycleIndex (CDMASCI) parameter indicates the preferred slot cycle length of a CDMA MS. The slot cycle length, T, in units of 1.28 seconds is given by $T = 2^i$, where i is the slot cycle index. The valid values are 0 through 7.

Field	Value	Type	Reference	Notes					
Identifier	CDMASlotCycleIndex IMPLICIT OCTET STRING	M	6.5.1.2						
Length	1 octet	M	6.5.1.1						
Contents									
H	G	F	E	D	C	B	A	octet	Notes
Reserved		Slot Cycle Index						1	a, b

Figure 47 CDMASlotCycleIndex parameter

Notes:

- a. See *CDMA SLOT_CYCLE_INDEX* for the definition of this field.
- b. Reserved bits shall be ignored on receipt and set to zero on sending.

6.5.2.41 CDMAStationClassMark

The CDMAStationClassMark (CDMASCM) parameter identifies certain characteristics of a dual-mode CDMA MS. This is used in accordance with the appropriate air interface.

Field	Value	Type	Reference	Notes					
Identifier	CDMAStationClassMark IMPLICIT OCTET STRING	M	6.5.1.2						
Length	variable octets	M	6.5.1.1						
Contents									
H	G	F	E	D	C	B	A	octet	Notes
Res'd	DMI	SMI	Reserved		DTX	PC		1	a
...								<i>n</i>	<i>b</i>

Figure 48 CDMAStationClassMark parameter

Notes:

- Reserved (Res'd) bits shall be ignored on receipt and set to zero on sending.
- Ignore extra octets, if received. Send only defined (or significant) octets.

Table 130 CDMAStationClassMark value

<i>Power Class: (PC)(octet 1, bits A and B)</i>										
Bits	H	G	F	E	D	C	B	A	Value	Meaning
									0 0	- Class 1
									0 1	- Class 2
									1 0	- Class 3
									1 1	- Reserved.
<i>Analog Transmission: (DTX) (octet 1, bit C)</i>										
Bits	H	G	F	E	D	C	B	A	Value	Meaning
									0	- Continuous.
									1	- Discontinuous.
<i>Slotted Mode Indicator: (SMI) (octet 1, bit F)</i>										
Bits	H	G	F	E	D	C	B	A	Value	Meaning
									0	- Slotted incapable. MS does not monitor the paging channel in .
									1	- Slotted capable. MS may monitor the paging channel in slotted mode.
<i>Dual-mode Indicator: (DMI) (octet 1, bit G)</i>										
Bits	H	G	F	E	D	C	B	A	Value	Meaning
									0	- CDMA only.
									1	- Dual-mode CDMA.

6.5.2.42 CDMATargetMAHOInformation

The CDMATargetMAHOInformation (CDMAMAHO) parameter specifies CDMA target cell information which is used in the handoff process.

Field	Value	Type	Reference	Notes
Identifier	CDMATargetMAHOInformation IMPLICIT SEQUENCE	M	6.5.1.2	
Length	variable	M	6.5.1.1	
Contents				
	TargetCellID	M	6.5.2.148	
	CDMAPilotStrength	M	6.5.2.35	
	CDMATargetOneWayDelay	M	6.5.2.46	
	...			a

Figure 49 CDMATargetMAHOInformation parameter

Notes:

- a. Ignore unexpected parameters, if received.

6.5.2.43 CDMATargetMAHOList

The CDMATargetMAHOList (CDMAMAHOList) parameter specifies CDMA target cell information which is used in the handoff process.

Field	Value	Type	Reference	Notes
Identifier	CDMATargetMAHOList IMPLICIT SEQUENCE OF	M	6.5.1.2	
Length	variable	M	6.5.1.1	
Contents				
	CDMATargetMAHOInformation	M	6.5.2.42	
	CDMATargetMAHOInformation	O	6.5.2.42	a
	...			

Figure 50 CDMATargetMAHOList parameter

Notes:

- a. Optionally include additional CDMATargetMAHOInformation parameters.

6.5.2.44 CDMATargetMeasurementInformation

The CDMATargetMeasurementInformation (CDMAMEAS) parameter specifies CDMA target cell information which is used in the handoff process.

Field	Value	Type	Reference	Notes
Identifier	CDMATargetMeasurementInformation IMPLICIT SEQUENCE	M	6.5.1.2	
Length	variable	M	6.5.1.1	
Contents				
TargetCellID		M	6.5.2.148	
CDMASignalQuality		M	6.5.2.39	
CDMATargetOneWayDelay		O	6.5.2.46	a
...				b

Figure 51 CDMATargetMeasurementInformation parameter

Notes:

- a. Include if available.
- b. Ignore unexpected parameters, if received.

6.5.2.45 CDMATargetMeasurementList

The CDMATargetMeasurementList (CDMAMEASLIST) parameter specifies CDMA target cell information which is used in the handoff process.

Field	Value	Type	Reference	Notes
Identifier	CDMATargetMeasurementList IMPLICIT SEQUENCE OF	M	6.5.1.2	
Length	Variable	M	6.5.1.1	
Contents				
CDMATargetMeasurementInformation		M	6.5.2.44	
CDMATargetMeasurementInformation		O	6.5.2.44	a
...				

Figure 52 CDMATargetMeasurementList parameter

Notes:

- a. Optionally include additional CDMATargetMeasurementInformation parameters.

6.5.2.46 CDMATargetOneWayDelay

This parameter was named TargetOneWayDelay prior to this revision of the Interim Standard.

The CDMATargetOneWayDelay (CDMATOWD) parameter specifies the estimated one-way delay from the MS to a target base station. The estimated delay can be converted to the estimated distance. The estimate can be used to minimize the search and acquisition times for the MS. The estimated one way delay between the MS and the associated base station is specified in units of 100 ns. The valid values are 0 through 65535.

Field	Value	Type	Reference	Notes					
Identifier	CDMATargetOneWayDelay IMPLICIT OCTET STRING	M	6.5.1.2						
Length	2 octets	M	6.5.1.1						
Contents									
H	G	F	E	D	C	B	A	octet	Notes
MSB								1	
CDMA Target One Way Delay								LSB	

Figure 53 CDMATargetOneWayDelay parameter

6.5.2.47 ChannelData

The ChannelData (CHDATA) parameter is used to indicate the SAT Color Code (SCC), Discontinuous Transmission Mode (DTX), Voice Mobile Attenuation Code (VMAC) and the of the channel being reported. SCC, DTX, VMAC, and CHNO are in accordance with *AMPS*, analog *TDMA*, *NAMPS*, and analog *CDMA*.

Field	Value	Type	Reference	Notes					
Identifier	ChannelData IMPLICIT OCTET STRING	M	6.5.1.2						
Length	zero or 3 octets	M	6.5.1.1	a					
Contents									
H	G	F	E	D	C	B	A	octet	Notes
SCC	Res'd	DTX		VMAC				1	b, c
MSB								Channel Number (CHNO)	2
								LSB	3

Figure 54 ChannelData parameter

Notes:

- a. An omitted CHDATA parameter or a CHDATA parameter with a length of 0 indicates that another channel data parameter (i.e., CDMAChannelData, TDMAChannelData, etc.) is used. Also, if the CHDATA parameter is applicable, the extended analog protocol parameter, NAMPSChannelData, may also be applicable.
- b. VMAC indicates the current power level of the MS associated with the analog channel being reported.
- c. Reserved (Res'd) bits shall be ignored on receipt and set to zero on sending.

Table 131 ChannelData value

<i>Discontinuous Transmission Mode (DTX) (octet 1, bits E and D)</i>										
Bits	H	G	F	E	D	C	B	A	Value	Meaning
				0	0				-	DTX disabled (not active/acceptable).
				0	1				-	Reserved. Treat the same as value 00, <i>DTX disabled</i> .
				1	0				-	DTX-low mode (i.e., 8 dB below DTX active/acceptable).
				1	1				-	DTX mode active or acceptable.

6.5.2.48 ConditionallyDeniedReason

The ConditionallyDeniedReason (CDEN) parameter indicates the reason access may not be given to the called MS.

Field	Value	Type	Reference	Notes					
Identifier	ConditionallyDeniedReason IMPLICIT Unsigned Enumerated	M	6.5.1.2						
Length	1 octet	M	6.5.1.1						
Contents									
H	G	F	E	D	C	B	A	octet	Notes
ConditionallyDeniedReason								1	

Figure 55 ConditionallyDeniedReason parameter

Table 132 ConditionallyDeniedReason value

<i>ConditionallyDeniedReason (octet 1)</i>										
Bits	H	G	F	E	D	C	B	A	Value	Meaning
	0	0	0	0	0	0	0	0	0	Not used.
	0	0	0	0	0	0	0	1	1	Waitable (i.e., Call Waiting is possible).
	0	0	0	0	0	0	1	0	2	} Reserved. Treat the same as value 1, <i>Waitable</i> .
				...					through	
	1	1	0	1	1	1	1	1	223	
	1	1	1	0	0	0	0	0	224	} Reserved for <i>TIA/EIA-41</i> protocol extension. If unknown, treat the same as value 1, <i>Waitable</i> .
				...					through	
	1	1	1	1	1	1	1	1	255	

6.5.2.49 ConferenceCallingIndicator

The ConferenceCallingIndicator (CCI) parameter is used to request that the ongoing call be transformed into a Conference Call. The parameter contains the maximum number of conferees that can be connected at any given time in the ongoing call.

Field	Value	Type	Reference	Notes					
Identifier	ConferenceCallingIndicator IMPLICIT OCTET STRING	M	6.5.1.2						
Length	variable octets	M	6.5.1.1						
Contents									
H	G	F	E	D	C	B	A	octet	Notes
Maximum Number of Conference								1	
...								<i>n</i>	<i>a</i>

Figure 56 ConferenceCallingIndicator parameter

Notes:

- a. Ignore extra octets, if received. Send only defined (or significant) octets.

Table 133 ConferenceCallingIndicator value

<i>Maximum Number of Conferees (octet 1)</i>										
Bits	H	G	F	E	D	C	B	A	Value	Meaning
	0	0	0	0	0	0	0	0	0	Not specified.
	0	0	0	0	0	0	0	1	1	} Maximum number of conferees.
				...					through	
	1	1	1	1	1	1	1	0	254	
	1	1	1	1	1	1	1	1	255	Unlimited number of conference.

6.5.2.50 ConfidentialityModes

The ConfidentialityModes (CMODES) parameter identifies the status of Signaling Message Encryption and Voice Privacy features for the MS and the subscriber's preference; on handoff, for example, the target MSC should attempt to provide the subscriber's preference regardless of the status in the serving MSC. Note that the ability to activate Voice Privacy is dictated by the CallingFeaturesIndicator (see 6.5.2.20) in the subscriber's profile.

In a FacilitiesDirective, FacilitiesDirective2, HandoffToThird, HandoffToThird2, HandoffBack, or HandoffBack2 operation INVOKE component, the CMODES-Desired indicates the subscriber's preference for Voice Privacy and the current state of Signaling Message Encryption in the Serving MSC. The Target MSC responds with CMODES-Actual in the RETURN RESULT component. This response indicates the modes that the target system will support following the handoff.

Field	Value	Type	Reference	Notes					
Identifier	ConfidentialityModes IMPLICIT OCTET STRING	M	6.5.1.2						
Length	1 octet	M	6.5.1.1						
Contents									
H	G	F	E	D	C	B	A	octet	Notes
Reserved						SE	VP	1	a

Figure 57 ConfidentialityModes parameter

Notes:

- a. Reserved bits shall be ignored on receipt and set to zero on sending.

Table 134 ConfidentialityModes value

<i>Voice Privacy (VP) Confidentiality Status (octet 1, bit A)</i>										
Bits	H	G	F	E	D	C	B	A	Value	Meaning
									0	- Off.
									1	- On.
<i>Signaling Message Encryption (SE) Confidentiality Status (octet 1, bit B)</i>										
Bits	H	G	F	E	D	C	B	A	Value	Meaning
									0	- Off.
									1	- On.

6.5.2.51 ControlChannelData

The ControlChannelData (CCDATA) parameter is used to indicate the Digital Color Code (DCC), Control Mobile Attenuation Code (CMAC), and the Channel Number (CHNO) of the access channel being reported. The contents of this parameter are in accordance with *AMPS*, *TDMA*, and *CDMA*.

Field	Value	Type	Reference	Notes					
Identifier	ControlChannelData IMPLICIT OCTET STRING	M	6.5.1.2						
Length	4 octets	M	6.5.1.1						
Contents									
H	G	F	E	D	C	B	A	octet	Notes
DCC		Reserved			CMAC			1	a, b
MSB							Channel Number (CHNO)		2
							LSB		3
Reserved				SDCC1		SDCC2		4	a, c

Figure 58 ControlChannelData parameter

Notes:

- a. Reserved bits shall be ignored on receipt and set to zero on sending.
- b. CMAC indicates the current power level of the MS associated with the channel being reported.
- c. If the Supplementary Digital Color Codes (SDCC1 and SDCC2) are not supported by either the MS or system, then they should be transmitted as zeroes.

6.5.2.52 CountUpdateReport

The CountUpdateReport (COUNTRPT) parameter indicates the outcome of the CallHistoryCount (COUNT) Update initiated by the AC or the VLR.

Field	Value	Type	Reference	Notes					
Identifier	CountUpdateReport IMPLICIT OCTET STRING	M	6.5.1.2						
Length	variable octets	M	6.5.1.1						
Contents									
H	G	F	E	D	C	B	A	octet	Notes
COUNT Update Report								1	
...								<i>n</i>	<i>a</i>

Figure 59 CountUpdateReport parameter

Notes:

- a. Ignore extra octets, if received. Send only defined (or significant) octets.

Table 135 CountUpdateReport value

<i>COUNT Update Report (octet 1)</i>										
Bits	H	G	F	E	D	C	B	A	Value	Meaning
	0	0	0	0	0	0	0	0	0	Not used.
	0	0	0	0	0	0	0	1	1	COUNT Update not Attempted.
	0	0	0	0	0	0	1	0	2	COUNT Update no response.
	0	0	0	0	0	0	1	1	3	COUNT Update successful.
	0	0	0	0	0	1	0	0	4	} Reserved. Treat the same as value 1, <i>COUNT Update not attempted.</i>
				...					through	
	1	1	0	1	1	1	1	1	223	
	1	1	1	0	0	0	0	0	224	} Reserved for <i>TIA/EIA-41</i> protocol extension. If unknown, treat the same as value 1, <i>COUNT Update not attempted.</i>
				...					through	
	1	1	1	1	1	1	1	1	255	

6.5.2.53 DeniedAuthorizationPeriod

The DeniedAuthorizationPeriod (DENAUTHPER) parameter is used to specify the interval before re-authorization. After this period has elapsed, the visited system shall attempt to obtain authorization from the home system again.

Field	Value	Type	Reference	Notes					
Identifier	DeniedAuthorizationPeriod IMPLICIT OCTET STRING	M	6.5.1.2						
Length	variable octets	M	6.5.1.1						
Contents									
H	G	F	E	D	C	B	A	octet	Notes
Period								1	
Value								2	a
...								n	b

Figure 60 DeniedAuthorizationPeriod parameter

Notes:

- a. The default value is 0.
- b. Ignore extra octets, if received. Send only defined (or significant) octets.

Table 136 DeniedAuthorizationPeriod value

<i>Period (octet 1)</i>										
Bits	H	G	F	E	D	C	B	A	Value	Meaning
	0	0	0	0	0	0	0	0	0	Not used.
	0	0	0	0	0	0	0	1	1	Per Call. Re-authorization should be attempted on the next call attempt.
	0	0	0	0	0	0	1	0	2	Hours.
	0	0	0	0	0	0	1	1	3	Days.
	0	0	0	0	0	1	0	0	4	Weeks.
	0	0	0	0	0	1	0	1	5	Per Agreement.
	0	0	0	0	0	1	1	0	6	Reserved.
	0	0	0	0	0	1	1	1	7	Number of calls. Re-authorization should be attempted after this number of (rejected) call attempts.
	0	0	0	0	1	0	0	0	8	Minutes.
	0	0	0	0	1	0	0	1	9	} Reserved. Treat the same as value 1, <i>Per Call.</i>
	1	1	0	1	1	1	1	1	223	
	1	1	1	0	0	0	0	0	224	} Reserved for <i>TIA/EIA-41</i> protocol extension. If unknown, treat the same as value 1, <i>Per Call.</i>
	1	1	1	1	1	1	1	1	255	

Table 136 (concluded)

<i>Value (octet 2)</i>										
Bits	H	G	F	E	D	C	B	A	Value	Meaning
	0	0	0	0	0	0	0	0	0	} Number of minutes hours, days, weeks, or number of calls (as per Period). If Period indicates anything else the Value is set to zero on sending and ignored on receipt.
				...					through	
	1	1	1	1	1	1	1	1	255	

6.5.2.54 DenyAccess

The DenyAccess (DENACC) parameter is used by the AC to indicate that the visiting MS to which the DenyAccess response applies is invalid.

Field	Value	Type	Reference	Notes					
Identifier	DenyAccess IMPLICIT Unsigned Enumerated	M	6.5.1.2						
Length	1 octet	M	6.5.1.1						
Contents									
H	G	F	E	D	C	B	A	octet	Notes
DenyAccess Reason								1	

Figure 61 DenyAccess parameter

Table 137 DenyAccess Reason value

<i>DenyAccess Reason (octet 1)</i>										
Bits	H	G	F	E	D	C	B	A	Value	Meaning
	0	0	0	0	0	0	0	0	0	Not used.
	0	0	0	0	0	0	0	1	1	Unspecified.
	0	0	0	0	0	0	1	0	2	SSD Update failure.
	0	0	0	0	0	0	1	1	3	COUNT Update failure.
	0	0	0	0	0	1	0	0	4	Unique Challenge failure.
	0	0	0	0	0	1	0	1	5	AUTHR mismatch.
	0	0	0	0	0	1	1	0	6	COUNT mismatch.
	0	0	0	0	0	1	1	1	7	Process collision.
	0	0	0	0	1	0	0	0	8	Missing authentication parameters.
	0	0	0	0	1	0	0	1	9	TerminalType mismatch.
	0	0	0	0	1	0	1	0	10	MIN or ESN authorization failure.
	0	0	0	0	1	0	1	1	11	} Reserved. Treat the same as value 1, <i>Unspecified.</i>
				...					through	
	1	1	0	1	1	1	1	1	223	
	1	1	1	0	0	0	0	0	224	} Reserved for <i>TIA/EIA-41</i> protocol extension. If unknown, treat the same as value 1, <i>Unspecified.</i>
				...					through	
	1	1	1	1	1	1	1	1	255	

6.5.2.55 DeregistrationType

The DeregistrationType (DEREG) parameter is used to request that an MS be deregistered when an MS is reported as *Inactive*. This allows deregistration and *Inactive* reporting to be separated.

Field	Value	Type	Reference	Notes					
Identifier	DeregistrationType IMPLICIT Unsigned Enumerated	M	6.5.1.2						
Length	1 octet	M	6.5.1.1						
Contents									
H	G	F	E	D	C	B	A	octet	Notes
DeregistrationType								1	

Figure 62 DeregistrationType parameter

Table 138 DeregistrationType value

<i>DeregistrationType (octet 1)</i>										
Bits	H	G	F	E	D	C	B	A	Value	Meaning
	0	0	0	0	0	0	0	0	0	Not used.
	0	0	0	0	0	0	0	1	1	Deregister for an unspecified reason.
	0	0	0	0	0	0	1	0	2	Deregister for an administrative reason (e.g., removal of VLR record).
	0	0	0	0	0	0	1	1	3	Deregister due to MS power down.
	0	0	0	0	0	1	0	0	4	} Reserved. Treat the same as value 1, <i>Deregister for an unspecified reason.</i>
				...					through	
	1	1	0	1	1	1	1	1	223	
	1	1	1	0	0	0	0	0	224	} Reserved for TIA/EIA-41 protocol extension. If unknown, treat the same as value 1, <i>Deregister for an unspecified reason.</i>
				...					through	
	1	1	1	1	1	1	1	1	255	

6.5.2.56 DestinationDigits

The DestinationDigits parameter specifies the network address of the called party for the purpose of call routing.

Field	Value	Type	Reference	Notes					
Identifier	DestinationDigits IMPLICIT DigitsType	M	6.5.1.2	a					
Length	variable octets	M	6.5.1.1						
Contents									
H	G	F	E	D	C	B	A	octet	Notes
Type of Digits								1	b
Nature of Number								2	c
Numbering Plan				Encoding				3	d, e
Number of Digits								4	f
2 nd BCD Digit				1 st BCD Digit				5	
4 th BCD Digit				3 rd BCD Digit				6	
...				
n^{th} BCD Digit				$n-1^{\text{st}}$ BCD Digit				m	

Figure 63 DestinationDigits parameter for BCD digits

Notes:

- a. Refer to the DigitsType parameter type (see 6.5.3.2) for notes and field encoding.
- b. The Type of Digits field is set to *Destination Number*.
- c. The Nature of Number field is set as applicable.
- d. The Numbering Plan field is set to *Telephony Numbering*.
- e. The Encoding field is set to *BCD*.
- f. The Number of Digits is between 0 and at least 15.

6.5.2.57 DigitCollectionControl

The DigitCollectionControl (DGTCC) parameter is used to control the collection of digits.

Field	Value	Type	Reference	Notes					
Identifier	DigitCollectionControl IMPLICIT OCTET STRING	M	6.5.1.2						
Length	variable octets	M	6.5.1.1	a					
Contents									
H	G	F	E	D	C	B	A	octet	Notes
BRK	TA	Res'd	MaximumCollect					1	b, c
Reserved		MinimumCollect					2	b, d	
MaximumInteractionTime							3	e	
Reserved		InitialInterdigitTime					4	b, f	
Reserved		NormalInterdigitTime					5	b, g	
ClearDigits DigitMask							6	b, h, i	
Reserved							7		
EnterDigits DigitMask							8	b, h, j	
Reserved							9		
AllowedDigits DigitMask							10	b, h, k	
Reserved							11		
Reserved		SpecialInterdigitTime					12	b, l	
SIT 8	SIT 7	SIT 6	SIT 5	SIT 4	SIT 3	SIT 2	SIT 1	13	l
SIT 16	SIT 15	SIT 14	SIT 13	SIT 12	SIT 11	SIT 10	SIT 9	14	l
SIT 24	SIT 23	SIT 22	SIT 21	SIT 20	SIT 19	SIT 18	SIT 17	15	l
Res'd	SIT 31	SIT 30	SIT 29	SIT 28	SIT 27	SIT 26	SIT 25	16	b, l
...								n	m

Figure 64 DigitCollectionControl parameter

Notes:

- a. If not all octets are sent, the unsent octets assume a default value. More values may be added to the end of the string in the future.
- b. Reserved (Res'd) bits shall be ignored on receipt and set to zero on sending.
- c. MaximumCollect defines the maximum number of digits to collect. Initially this maximum must be 32 digits or less. Zero (0) indicates that the digits should be collected until an EnterDigit is entered, the user abandons the call, or the collection times out. Other values cause collection until the MaximumCollect number of digits are received (in addition to the other criteria). By default a zero (0) value is assumed.
- d. MinimumCollect defines the minimum number of digits to collect. This should be less than or equal to the MaximumCollect number. Zero (0) indicates that there is no minimum number of digits to collect. Other values cause a replaying of the announcement if less digits than the MinimumCollect are entered when an EnterDigit is entered or the collection times out. By default a zero (0) value is assumed.

- 1
2
3
4
5
6
7
8
9
10
11
12
13
14
15
16
17
18
19
- e. The `MaximumInteractionTime` defines the amount of time in seconds allowed to collect a string of digits including announcement(s) and any retries. This is fairly long to allow the user to enter all digits and possible correct them. By default this is 1 minute.
 - f. `InitialInterdigitTime` defines the amount of time in seconds between the end of the announcement and when collection is declared completed without digits entered. This should be fairly short (less than 15 seconds) for PSTN interactions to wait to redirect a non-DTMF phone. If an MS subscriber is expected to use *en bloc* sending of digits, this time may be long enough to enter the entire number. This timer is restarted if the user uses a `ClearDigit`. By default this is 15 seconds.
 - g. The `NormalInterdigitTime` defines the normal amount of time in seconds allowed between key strokes. This is usually fairly short (on the order of 5 to 10 seconds). By default this is 5 seconds.
 - h. The `ClearDigits`, `EnterDigits`, and `AllowedDigits` fields use the following `DigitMask` to select individual digits:

20
21
22
23
24

H	G	F	E	D	C	B	A	octet
7 Digit	6 Digit	5 Digit	4 Digit	3 Digit	2 Digit	1 Digit	0 Digit	1st
Reserved			# Digit	* Digit	Resd	9 Digit	8 Digit	2nd

25
26

Figure 65 Format of DigitMask Fields

- 27
28
29
30
31
32
33
34
35
36
37
38
39
40
41
42
43
44
45
46
47
48
49
50
51
52
53
54
55
56
57
58
59
60
- i. `ClearDigits` applies the `DigitMask` (Figure 55) to define the digits that cause the buffered digits to be discarded, so that the digits may be re-entered. A one (1) value in the mask causes the corresponding digit to be treated as a clear digit. Digits with a corresponding zero (0) values are ignored. Zero or more bits may have the one value. By default there are no clear digits.
 - j. `EnterDigits` applies the `DigitMask` (Figure 55) to define the digits that cause the buffered digits to be sent, thereby ending this entry. A one (1) value in the mask causes the corresponding digit to be treated as an enter digit. Digits with a corresponding zero (0) values are ignored. Zero or more bits may have the one value. By default the pound (#) key is the enter digit.
 - k. `AllowedDigits` applies the `DigitMask` (Figure 55) to define the digits that are buffered. A one (1) value in the mask causes the corresponding digit to be buffered. Digits with a corresponding zero (0) values are ignored. Zero or more bits may have the one value. By default all digits are buffered.
 - l. The `SpecialInterdigitTime` (SIT) overrides the applicable `NormalInterdigitTime` after the digits with the corresponding SIT bit set to a one (1) value. SIT 1 applies after the first digit, SIT 2 applies after the second digit, and so on. This allows for shorter timers to be applied for digit strings that may have special lengths, such as, 1, 3, 7, and 10 for the North American Numbering Plan. By default special interdigit timing does not apply.
 - m. Ignore extra octets, if received. Send only defined (or significant) octets.

Table 139 DigitCollectionControl value

<i>TypeAhead (TA) (octet 1, bit G)</i>										
Bits	H	G	F	E	D	C	B	A	Value	Meaning
		0							0	NoTypeAhead. Ignore digits received before the end of the announcement.
		1							1	Buffer (default). Allow digits to be received and collected before the end of the announcement.
<i>Break (BRK) (octet 1, bit H)</i>										
Bits	H	G	F	E	D	C	B	A	Value	Meaning
		0							0	NoBreak. Ignore digits received before the end of the announcement for purposes of controlling the announcement.
		1							1	BreakIn (default). Allow digits received before or during an announcement to cut the announcement off.

1
2
3
4
5
6
7
8
9
10
11
12
13
14
15
16
17
18
19
20
21
22
23
24
25
26
27
28
29
30
31
32
33
34
35
36
37
38
39
40
41
42
43
44
45
46
47
48
49
50
51
52
53
54
55
56
57
58
59
60

6.5.2.58 Digits

The Digits parameter is based on the Digits parameter defined in Section 3 of *ANSI T1.114-1988*. Where there are differences, this Standard takes precedence.

Field	Value	Type	Reference	Notes					
Identifier	Digits IMPLICIT DigitsType	M	6.5.1.2	a					
Length	variable octets	M	6.5.1.1						
Contents									
H	G	F	E	D	C	B	A	octet	Notes
Type of Digits								1	b
Nature of Number								2	c
Numbering Plan				Encoding				3	d, e
Number of Digits								4	f
2 nd BCD Digit				1 st BCD Digit				5	
4 th BCD Digit				3 rd BCD Digit				6	
...				
<i>n</i> th BCD Digit				<i>n</i> -1 st BCD Digit				<i>m</i>	

Figure 66 Digits parameter for BCD digits

Notes for all Digits parameter variants:

- a. Refer to the DigitsType parameter type (see 6.5.3.2) for notes and field encoding.
- d. The Numbering Plan field is set to *Telephony Numbering*.
- e. The Encoding field is set to *BCD*.

Notes for the Digits (Dialed) as the dialed number variant:

- b. The Type of Digits field is set to *Dialed Number*. The digits are the digits dialed by an MS with an unknown Nature of Number (or Numbering Plan).
- c. The Nature of Number field is ignored on receipt.
- f. The Number of Digits is between 0 and 32.

Notes for the Digits (Dialed) as the called number variant:

- b. The Type of Digits field is set to *Dialed Number*. The digits should be a directory number assigned to a MS or for other specialized purposes.
- c. The Nature of Number field is *National*.
- f. The Number of Digits is 10 for a North American Numbering Plan number, #
although this may vary by country or by bilateral agreement. #

Notes for the Digits (Carrier) variant:

- b. The Type of Digits field is set to *Carrier*.
- c. The Nature of Number field is *National* or *International*.

Notes for the Digits (Destination) as a profile restriction variant:

- b. The Type of Digits field is set to *Destination Number*. The digits specify a national leading digits of the directory or a full directory number used to restrict the numbers dialed by an MS as indicated by the OriginationIndicator parameter.
- c. The Nature of Number field is set to *National*.
- f. The Number of Digits is either 6 or 10 for NANP. #

Notes for the Digits (Destination) as a network destination variant:

- b. The Type of Digits field is set to *Destination Number*. The digits specify a telephone network destination address.
- c. The Nature of Number field is set as necessary:
 - i. from NANP countries to destinations within NANP, the digits should consist of 10 digits without prefix digits. The Nature of Number field is set to *National*. #
 - ii. from non NANP countries to destinations within NANP, the Nature of Number field is set to *International*. #
 - iii. for destinations within the same country outside of NANP, the digits should consist of a national number without prefix digits. The Nature of Number field is set to *National*. #
 - iv. for destinations between countries outside of NANP, the digits shall consist of a country code followed by a national number without prefix digits. The Nature of Number field is set to *International*. #
 - v. for destinations between different systems (even within the same country), the digits may consist of a country code followed by a national number without prefix digits. The Nature of Number field is set to *International*.
 - vi. from NANP countries to destinations outside of NANP, the digits may consist of a country code followed by a national number without prefix digits. The Nature of Number field is set to *International*. #
- f. The Number of Digits is between 0 and at least 15. #

6.5.2.59 DMH_AccountCodeDigits

The DMH_AccountCodeDigits (ACDGTS) parameter specifies the account code digits as dialed by a subscriber. The account code is defined between the subscriber and the home cellular service provider.

Field	Value	Type	Reference	Notes					
Identifier	DMH_AccountCodeDigits IMPLICIT DigitsType	M	6.5.1.2	a					
Length	variable octets	M	6.5.1.1						
Contents									
H	G	F	E	D	C	B	A	octet	Notes
Type of Digits								1	b
Nature of Number								2	c
Numbering Plan				Encoding				3	d, e
Number of Digits								4	f
2 nd BCD Digit				1 st BCD Digit				5	
4 th BCD Digit				3 rd BCD Digit				6	
...				
n^{th} BCD Digit				$n-1^{\text{st}}$ BCD Digit				m	

Figure 67 DMH_AccountCodeDigits parameter for BCD digits

Notes:

- a. Refer to the DigitsType parameter type (see 6.5.3.2) for notes and field encoding.
- b. The Type of Digits field is ignored on receipt.
- c. The Nature of Number field is ignored on receipt.
- d. The Numbering Plan field is ignored on receipt.
- e. The Encoding field is set to *BCD*.
- f. The Number of Digits is between 0 and at least 15.

6.5.2.60 DMH_AlternateBillingDigits

The DMH_AlternateBillingDigits (ABDGTS) parameter specifies a non-telephony billing number, such as a calling card number, credit card account number, debit card account code, etc. The DMH_AlternateBillingDigits is supplied and screened by a subscriber's home cellular service provider.

The account responsible for a call is based upon the presence of the following parameters in order of precedence:

- a. DMH_AlternateBillingDigits.
- b. DMH_BillingDigits.
- c. MobileDirectoryNumber.
- d. MobileIdentificationNumber.

Field	Value	Type	Reference	Notes					
Identifier	DMH_AlternateBillingDigits IMPLICIT DigitsType	M	6.5.1.2	a					
Length	variable octets	M	6.5.1.1						
Contents									
H	G	F	E	D	C	B	A	octet	Notes
Type of Digits								1	b
Nature of Number								2	c
Numbering Plan				Encoding				3	d, e
Number of Digits								4	f
2 nd BCD Digit				1 st BCD Digit				5	
4 th BCD Digit				3 rd BCD Digit				6	
...				
n^{th} BCD Digit				$n-1^{\text{st}}$ BCD Digit				m	

Figure 68 DMH_AlternateBillingDigits parameter for BCD digits

Notes:

- a. Refer to the DigitsType parameter type (see 6.5.3.2) for notes and field encoding.
- b. The Type of Digits field is ignored on receipt.
- c. The Nature of Number field is ignored on receipt.
- d. The Numbering Plan field is ignored on receipt.
- e. The Encoding field is set to *BCD*.
- f. The Number of Digits is between 0 and at least 15.

6.5.2.61 DMH_BillingDigits

The DMH_BillingDigits (BILLDGTS) parameter specifies the telephony billing number used for calls with special billing arrangements to identify the party to be billed, such as third party billing, calling card, etc. The billing number must be a valid telephony number for billing the call.

The account responsible for a call is based upon the presence of the following parameters in order of precedence:

- a. DMH_AlternateBillingDigits.
- b. DMH_BillingDigits.
- c. MobileDirectoryNumber.
- d. MobileIdentificationNumber.

The network charge number for a call is determined by the presence of the following parameters in order of precedence:

- a. DMH_BillingDigits.
- b. MobileDirectoryNumber.
- c. MobileIdentificationNumber.

Field	Value	Type	Reference	Notes					
Identifier	DMH_BillingDigits IMPLICIT DigitsType	M	6.5.1.2	a					
Length	variable octets	M	6.5.1.1						
Contents									
H	G	F	E	D	C	B	A	octet	Notes
Type of Digits								1	b
Nature of Number								2	c
Numbering Plan				Encoding				3	d, e
Number of Digits								4	f
2 nd BCD Digit				1 st BCD Digit				5	
4 th BCD Digit				3 rd BCD Digit				6	
...				
<i>n</i> th BCD Digit				<i>n</i> -1 st BCD Digit				<i>m</i>	

Figure 69 DMH_BillingDigits parameter for BCD digits

Notes:

- a. See the DigitsType parameter type (see 6.5.3.2) for notes and field encoding.
- b. The Type of Digits field is set to *Billing Number*.
- c. The Nature of Number field is ignored on receipt.
- d. The Numbering Plan field is ignored on receipt.
- e. The Encoding field is set to *BCD*.
- f. The Number of Digits is between 0 and at least 15.

6.5.2.62 DMH_RedirectionIndicator

The DMH_RedirectionIndicator (REDIND) parameter indicates the reason for extending an incoming call for recording purposes.

Field	Value	Type	Reference	Notes						
Identifier	DMH_RedirectionIndicator IMPLICIT ENUMERATED	M	6.5.1.2							
Length	variable octets	M	6.5.1.1	a						
Contents										
H	G	F	E	D	C	B	A	octet	Notes	
Sign	MSB Redirection Indicator						LSB		1	
•••								<i>n</i>		

Figure 70 DMH_RedirectionIndicator parameter

Notes:

- a. If a value is received using more octets than supported, change the received value to value 0, *Not specified*.

Table 140 DMH_RedirectionIndicator value

<i>Redirection Indicator (octet 1)</i>										
Bits	H	G	F	E	D	C	B	A	Value	Meaning
	0	0	0	0	0	0	0	0	0	Not specified. The type of redirection is not defined in this Standard.
	0	0	0	0	0	0	0	1	1	CFU . The call was redirected for Call Forwarding–Unconditional.
	0	0	0	0	0	0	1	0	2	CFB . The call was redirected for Call Forwarding–Busy.
	0	0	0	0	0	0	1	1	3	CFNA . The call was redirected for Call Forwarding–No Answer.
	0	0	0	0	0	1	0	0	4	CFO . The call was redirected for Call Forwarding–Other. Note that this is not an [TIA/EIA-664] feature.
	0	0	0	0	0	1	0	1	5	CD Unspecified . The call was redirected for Call Delivery via an unspecified network.
	0	0	0	0	0	1	1	0	6	CD PSTN . The call was redirected for Call Delivery via the PSTN.
	0	0	0	0	0	1	1	1	7	CD Private . The call was redirected for Call Delivery via private facilities.
	0	0	0	0	1	0	0	0	8	PSTN Tandem . The call was routed as a PSTN tandem call.
	0	0	0	0	1	0	0	1	9	Private Tandem . The call was routed as a private facility tandem call.
	0	0	0	0	1	0	1	0	10	Busy . The call was redirected because the addressed subscriber was busy.
	0	0	0	0	1	0	1	1	11	Inactive . The call was redirected because the addressed subscriber was inactive.
	0	0	0	0	1	1	0	0	12	Unassigned . The call was redirected because the addressed directory number was unassigned.

1
2
3
4
5
6
7
8
9
10
11
12
13
14
15
16
17
18
19
20
21
22
23
24
25
26
27
28
29
30
31
32
33
34
35
36
37
38
39
40
41
42
43
44
45
46
47
48
49
50
51
52
53
54
55
56
57
58
59
60

Table 140 (concluded)

0 0 0 0 1 1 0 1	13	Termination Denied. The call was redirected because termination was denied.
0 0 0 0 1 1 1 0	14	CD Failure. The call was redirected because of a <i>TIA/EIA-41</i> Call Delivery failure.
0 0 0 0 1 1 1 1	15	ECT. The call was redirected because of . Note that this is not an [<i>TIA/EIA-664</i>] feature. This is assumed to be a “one step” where a bridge is not involved and the invoking subscriber immediately drops out of the call.
0 0 0 1 0 0 0 0	16	MAH. The call was redirected for Mobile Access Hunting call delivery attempt.
0 0 0 1 0 0 0 1	17	FA. The call was redirected for Flexible Alerting call delivery attempt.
0 0 0 1 0 0 1 0	18	Abandoned Call Leg. The call was redirected because a call leg was abandoned.
0 0 0 1 0 0 1 1	19	PCA call refused. Password Call Acceptance (PCA) call was refused.
0 0 0 1 0 1 0 0	20	SCA call refused. Selective Call Acceptance (SCA) call was refused.
0 0 0 1 0 1 0 1	21	Dialogue.
0 0 0 1 0 1 1 0	22	CFD. The call was redirected for Call Forwarding-Default.
0 0 0 1 0 1 1 1	23	CD Local. The call was redirected for Call Delivery locally.
0 0 0 1 1 0 0 0	24	Voice Mail Retrieval. The call was redirected for Voice Mail Retrieval.

Redirection Indicator (octet 1)

Bits	H	G	F	E	D	C	B	A	Value	Meaning
	0	0	0	1	1	0	0	1	25	} Reserved. Treat the same as value 0, <i>Not specified.</i>
				...					through 127	
	1	1	1	1	1	1	1	1	-1	} Reserved for bilateral agreements.
				...					through -128	

6.5.2.63 ElectronicSerialNumber

This parameter was named MobileSerialNumber prior to this revision of the Interim Standard.

The ElectronicSerialNumber (ESN) parameter is used to indicate the unique 32-bit electronic serial number of an MS.

Field	Value	Type	Reference	Notes					
Identifier	ElectronicSerialNumber IMPLICIT OCTET STRING	M	6.5.1.2						
Length	4 octets	M	6.5.1.1						
Contents									
H	G	F	E	D	C	B	A	octet	Notes
Manufacturer's Code								1	a
MSB Serial Number LSB								2	a
								3	
								4	

Figure 71 ElectronicSerialNumber parameter

Notes:

- a. See *AMPS*, *NAMPS*, *TDMA*, or *CDMA* for encoding of these fields.

6.5.2.64 ExtendedMSCID

The ExtendedMSCID (EXTMSCID) parameter indicates the ID of the specified system, and the type of system.

Field	Value	Type	Reference	Notes					
Identifier	ExtendedMSCID IMPLICIT OCTET STRING	M	6.5.1.2						
Length	4 octets	M	6.5.1.1						
Contents									
H	G	F	E	D	C	B	A	octet	Notes
Type								1	
MSB MarketID								2	a
LSB								3	
Switch Number								4	a

Figure 72 ExtendedMSCID parameter

Notes:

- a. Refer to the MSCID parameter (see 6.5.2.82) for the definition of these fields.

Table 141 ExtendedMSCID value

<i>Type (octet 1)</i>										
Bits	H	G	F	E	D	C	B	A	Value	Meaning
	0	0	0	0	0	0	0	0	0	Not specified
	0	0	0	0	0	0	0	1	1	Serving MSC.
	0	0	0	0	0	0	1	0	2	Home MSC.
	0	0	0	0	0	0	1	1	3	Gateway MSC.
	0	0	0	0	0	1	0	0	4	HLR.
	0	0	0	0	0	1	0	1	5	VLR.
	0	0	0	0	0	1	1	0	6	EIR (reserved).
	0	0	0	0	0	1	1	1	7	AC.
	0	0	0	0	1	0	0	0	8	Border MSC.
	0	0	0	0	1	0	0	1	9	Originating MSC.
	0	0	0	0	1	0	1	0	10	} Reserved. Treat reserved values the same as value 0, <i>Not specified</i> .
				...					through	
	1	1	0	1	1	1	1	1	223	
	1	1	1	0	0	0	0	0	224	} Reserved for <i>TIA/EIA-41</i> protocol extension. If unknown, treat the same as value 0, <i>Not specified</i> .
				...					through	
	1	1	1	1	1	1	1	1	255	

6.5.2.65 ExtendedSystemMyTypeCode

The ExtendedSystemMyTypeCode (EXTMYTYP) parameter indicates the manufacturer of the system and its role in the network.

Field	Value	Type	Reference	Notes					
Identifier	ExtendedSystemMyTypeCode IMPLICIT OCTET STRING	M	6.5.1.2						
Length	2 octets	M	6.5.1.1						
Contents									
H	G	F	E	D	C	B	A	octet	Notes
Type								1	
SystemMyTypeCode Identifier								2	a

Figure 73 ExtendedSystemMyTypeCode parameter

Notes:

- a. This octet is encoded the same as octet 1 in the SystemMyTypeCode parameter (see 6.5.2.147).

Table 142 ExtendedSystemMyTypeCode value

<i>Type (octet 1)</i>										
Bits	H	G	F	E	D	C	B	A	Value	Meaning
	0	0	0	0	0	0	0	0	0	Not specified
	0	0	0	0	0	0	0	1	1	Serving MSC.
	0	0	0	0	0	0	1	0	2	Home MSC.
	0	0	0	0	0	0	1	1	3	Gateway MSC.
	0	0	0	0	0	1	0	0	4	HLR.
	0	0	0	0	0	1	0	1	5	VLR.
	0	0	0	0	0	1	1	0	6	EIR (reserved).
	0	0	0	0	0	1	1	1	7	AC.
	0	0	0	0	1	0	0	0	8	Border MSC.
	0	0	0	0	1	0	0	1	9	Originating MSC.
	0	0	0	0	1	0	1	0	10	} Reserved. Treat reserved values the same as value 0, <i>Not specified</i> .
				...					through	
	1	1	0	1	1	1	1	1	223	
	1	1	1	0	0	0	0	0	224	} Reserved for <i>TIA/EIA-41</i> protocol extension. If unknown, treat the same as value 0, <i>Not specified</i> .
				...					through	
	1	1	1	1	1	1	1	1	255	

6.5.2.66 FaultyParameter

The FaultyParameter parameter identifies a parameter which has been determined to be in error. Only a single occurrence of this parameter is defined in RETURN ERROR components containing an Error Code of *MissingParameter*, *ParameterError*, or *UnrecognizedParameterValue*. It should not occur in RETURN ERROR messages containing other Error Code values. If the detected problem is the presence of two or more mutually exclusive parameters, report the first parameter found. If the detected problem is more than one missing, but expected or required, optional parameter; report only one of the missing parameters.

Field	Value	Type	Reference	Notes					
Identifier	FaultyParameter IMPLICIT OCTET STRING	M	6.5.1.2						
Length	variable octets	M	6.5.1.1						
Contents									
H	G	F	E	D	C	B	A	octet	Notes
Parameter Identifier								1Én	a

Figure 74 FaultyParameter parameter

Notes:

- a. See 6.5.1.2. for the list of valid Parameter Identifiers. Ignore reserved values, except for auditing purposes.

6.5.2.67 FeatureResult

This parameter was named RemoteFeatureOperationResult prior to this revision of the Interim Standard.

The FeatureResult (FEATRESULT) parameter indicates whether the associated feature request was successful or unsuccessful.

Field	Value	Type	Reference	Notes					
Identifier	FeatureResult IMPLICIT Unsigned Enumerated	M	6.5.1.2						
Length	1 octet	M	6.5.1.1						
Contents									
H	G	F	E	D	C	B	A	octet	Notes
Feature Result								1	

Figure 75 FeatureResult parameter

Table 143 FeatureResult value

<i>Feature Result (octet 1)</i>										
Bits	H	G	F	E	D	C	B	A	Value	Meaning
	0	0	0	0	0	0	0	0	0	Not used.
	0	0	0	0	0	0	0	1	1	Unsuccessful.
	0	0	0	0	0	0	1	0	2	Successful.
	0	0	0	0	0	0	1	1	3	} Reserved. Treat the same as value 1, <i>Unsuccessful.</i>
				...					through 95	
	0	1	0	1	1	1	1	1	96	} Reserved for TIA/EIA-41 protocol extension (Unsuccessful values). If unknown, treat the same as value 1, <i>Unsuccessful.</i>
				...					through 127	
	1	0	0	0	0	0	0	0	128	} Reserved. Treat the same as value 2, <i>Successful.</i>
				...					through 223	
	1	1	0	1	1	1	1	1	224	} Reserved for TIA/EIA-41 protocol extension (Successful values). If unknown, treat the same as value 2, <i>Successful.</i>
				...					through 255	

6.5.2.68 GeographicAuthorization

The GeographicAuthorization (GEOAUTH) parameter indicates the geographic authorization capability of an MS.

Field	Value	Type	Reference	Notes					
Identifier	GeographicAuthorization IMPLICIT OCTET STRING	M	6.5.1.2						
Length	variable octets	M	6.5.1.1						
Contents									
H	G	F	E	D	C	B	A	octet	Notes
Geographic Authorization								1	
...								<i>n</i>	<i>a</i>

Figure 76 GeographicAuthorization parameter

Notes:

- a. Ignore extra octets, if received. Send only defined (or significant) octets.

Table 144 GeographicAuthorization value

<i>Geographic Authorization (octet 1)</i>										
Bits	H	G	F	E	D	C	B	A	Value	Meaning
	0	0	0	0	0	0	0	0	0	Not used.
	0	0	0	0	0	0	0	1	1	Authorized for all MarketIDs served by the VLR.
	0	0	0	0	0	0	1	0	2	Authorized for this MarketID only.
	0	0	0	0	0	0	1	1	3	Authorized for this MarketID and Switch Number only.
	0	0	0	0	0	1	0	0	4	Authorized for this LocationAreaID within a MarketID only.
	0	0	0	0	0	1	0	1	5	} Reserved. Treat the same as value 1, Authorized for all MarketIDs served by the VLR.
	0	1	0	1	1	1	1	1	95	
	0	1	1	0	0	0	0	0	96	} Reserved for TIA/EIA-41 protocol extension. If unknown, treat the same as value 1, Authorized for all MarketIDs served by the VLR.
	0	1	1	1	1	1	1	1	127	
	1	0	0	0	0	0	0	0	128	} Reserved. Treat the same as value 4, Authorized for this LocationAreaID within a MarketID only.
	1	1	0	1	1	1	1	1	223	
	1	1	1	0	0	0	0	0	224	} Reserved for TIA/EIA-41 protocol extension. If unknown, treat the same as value 4, Authorized for this LocationAreaID within a MarketID only.
	1	1	1	1	1	1	1	1	255	

6.5.2.69 GroupInformation

The GroupInformation (GRPINFO) parameter carries information associated with the Pilot Directory Number of a multileg call.

Field	Value	Type	Reference	Notes					
Identifier	GroupInformation IMPLICIT OCTET STRING	M	6.5.1.2						
Length	variable octets	M	6.5.1.1						
Contents									
H	G	F	E	D	C	B	A	octet	Notes
<div style="display: flex; justify-content: space-between;"> MSB GroupInformation LSB </div>								1	
								2	
								3	
								4	
...								<i>n</i>	<i>a</i>

Figure 77 GroupInformation parameter

Notes:

- a. Ignore extra octets, if received. Send only defined (or significant) octets.

6.5.2.70 HandoffReason

The HandoffReason (HANDREASON) parameter is sent to the target system from the serving system to indicate the reason for the handoff.

Field	Value	Type	Reference	Notes					
Identifier	HandoffReason IMPLICIT Unsigned Enumerated	M	6.5.1.2						
Length	1 octet	M	6.5.1.1						
Contents									
H	G	F	E	D	C	B	A	octet	Notes
Handoff Reason								1	

Figure 78 HandoffReason parameter

Table 145 HandoffReason value

<i>Handoff Reason (octet 1)</i>										
Bits	H	G	F	E	D	C	B	A	Value	Meaning
	0	0	0	0	0	0	0	0	0	Not used.
	0	0	0	0	0	0	0	1	1	Unspecified.
	0	0	0	0	0	0	1	0	2	Weak Signal.
	0	0	0	0	0	0	1	1	3	Off-loading.
	0	0	0	0	0	1	0	0	4	Anticipatory (i.e., in anticipation of a future weak signal).
	0	0	0	0	0	1	0	1	5	} Reserved. Treat the same as value 1, <i>Unspecified.</i>
				...					through 223	
	1	1	0	1	1	1	1	1	223	
	1	1	1	0	0	0	0	0	224	} Reserved for <i>TIA/EIA-41</i> protocol extension . If unknown, treat the same as value 1, <i>Unspecified.</i>
				...					through 255	
	1	1	1	1	1	1	1	1	255	

6.5.2.71 HandoffState

The HandoffState (HOSTATE) parameter indicates that the MS is currently involved in a call that is in the awaiting answer or alerting state.

Field	Value	Type	Reference	Notes					
Identifier	HandoffState IMPLICIT OCTET STRING	M	6.5.1.2						
Length	variable octets	M	6.5.1.1						
Contents									
H	G	F	E	D	C	B	A	octet	Notes
Reserved							PI	1	a
...								<i>n</i>	b

Figure 79 HandoffState parameter

Notes:

- a. Reserved bits shall be ignored on receipt and set to zero on sending.
- b. Ignore extra octets, if received. Send only defined (or significant) octets.

Table 146 HandoffState value

<i>Party Involved (PI) (octet 1, bit A)</i>										
Bits	H	G	F	E	D	C	B	A	Value	Meaning
								0	0	Originator is handing off (i.e., handle as normal handoff).
								1	1	Terminator is handing off (i.e., place MS on voice channel in the alerting state).

6.5.2.72 InterMSCCircuitID

The InterMSCCircuitID (IMSCCID) parameter is used to identify a specific trunk in a dedicated trunk group between two MSCs. This number consists of a trunk group number and member number.

Field	Value	Type	Reference	Notes					
Identifier	InterMSCCircuitID IMPLICIT OCTET STRING	M	6.5.1.2						
Length	2 octets	M	6.5.1.1						
Contents									
H	G	F	E	D	C	B	A	octet	Notes
Trunk Group Number (G)								1	
Trunk Member Number (M)								2	

Figure 80 InterMSCCircuitID parameter

6.5.2.73 InterSwitchCount

The InterSwitchCount (ISCOUNT) parameter consists of a single octet containing an eight bit binary number whose value indicates either:

- (a) the number of inter-MSC facilities that will be transited by the call (including the Anchor MSC) at the successful conclusion of a pending handoff forward or intersystem call setup, or
- (b) the number of inter-MSC facilities in use before the handoff between the Anchor MSC and the Serving MSC.

Item (a) applies to the use of InterSwitchCount in the FacilitiesDirective, FacilitiesDirective2 or InterSystemSetup operations; item (b) applies to the use of InterSwitchCount in the HandoffToThird or HandoffToThird2 operations.

No limit on the value of the InterSwitchCount is imposed by this standard, but one may be established between system operators, through configuration of the MAXHANDOFF and TANDEMDEPTH system parameters.

Field	Value	Type	Reference	Notes					
Identifier	InterSwitchCount IMPLICIT Unsigned Integer (0..255)	M	6.5.1.2						
Length	1 octet	M	6.5.1.1						
Contents									
H	G	F	E	D	C	B	A	octet	Notes
InterSwitchCount								1	

Figure 81 InterSwitchCount parameter

6.5.2.74 IntersystemTermination

The IntersystemTermination (ISTERM) parameter is used to provide an MSC with routing information for calls which are to be terminated on another MSC.

Field	Value	Type	Reference	Notes
Identifier	IntersystemTermination IMPLICIT SET	M	6.5.1.2	
Length	variable	M	6.5.1.1	
Contents				
DestinationDigits		M	6.5.2.56	
MSCID (Serving)		M	6.5.2.82	
AccessDeniedReason		O	6.5.2.1	a
BillingID (Terminating)		O	6.5.2.16	b
CarrierDigits		O	6.5.2.28	c, d
ElectronicSerialNumber		O	6.5.2.63	e
LegInformation		O	6.5.2.75	f
MobileDirectoryNumber		O	6.5.2.80	d, e
MobileIdentificationNumbde		O	6.5.2.81	e
MSCIdentificationNumber		O	6.5.2.83	g
RoutingDigits		O	6.5.2.114	d, h
TerminationTriggers		O	6.5.2.159	d, i
•••				j

Figure 82 IntersystemTermination parameter

Notes:

- a. Include if access may be denied.
- b. Required for recording purposes (see *DMH*).
- c. Include to select interexchange carrier or international carrier.
- d. This parameter has precedence for this call leg over the parameters outside the TerminationList parameter or the subscriber's profile.
- e. Include for recording purposes, if TerminationTreatment indicates that termination is to an MS.
- f. Include if part of a multileg call.
- g. Include to identify the Serving MSC.
- h. Include for special steering.
- i. Include for subsequent redirection.
- j. Ignore unexpected parameters, if received.

6.5.2.75 LegInformation

The LegInformation (LEGINFO) parameter identifies a particular leg of a multiple termination call (e.g., a Flexible Alerting call) assigned by the HLR. Note that this is different than the LegNumber assigned by an MSC for *DMH* purposes.

Field	Value	Type	Reference	Notes					
Identifier	LegInformation IMPLICIT OCTET STRING	M	6.5.1.2						
Length	variable octets	M	6.5.1.1						
Contents									
H	G	F	E	D	C	B	A	octet	Notes
MSB HLR Leg Number LSB								1	
								2	
								3	
								4	
...								<i>n</i>	a

Figure 83 LegInformation parameter

Notes:

- a. Ignore extra octets, if received. Send only defined (or significant) octets.

6.5.2.76 LocalTermination

The LocalTermination (LOCTERM) parameter is used to provide an MSC with routing information for calls which are to be terminated on the same MSC.

Field	Value	Type	Reference	Notes
Identifier	LocalTermination IMPLICIT SET	M	6.5.1.2	
Length	Variable	M	6.5.1.1	
Contents				
	ElectronicSerialNumber	M	6.5.2.63	
	MobileIdentificationNumber	M	6.5.2.81	
	TerminationTreatment	M	6.5.2.158	
	AlertCode	O	6.5.2.3	a, b
	CarrierDigits	O	6.5.2.28	b, c
	DestinationDigits	O	6.5.2.56	d, e
	LegInformation	O	6.5.2.75	a
	MobileDirectoryNumber	O	6.5.2.80	b, f
	OneTimeFeatureIndicator	O	6.5.2.88	b, g
	RoutingDigits	O	6.5.2.114	b, h
	TerminationTriggers	O	6.5.2.159	a, b
	VoiceMailboxPIN	O	6.5.2.165	i
	VoiceMailboxNumber	O	6.5.2.164	j
	•••			k

Figure 84 LocalTermination parameter

Notes:

- a. Optional, if the TerminationTreatment indicates termination to an MS.
- b. This parameter has precedence for this call leg over the parameters outside the TerminationList parameter or the subscriber's profile.
- c. Optional, for intra-MS call routing.
- d. Optionally include if TerminationTreatment parameter value is *Dialogue*, to select a dialogue or to provide information to a dialogue.
- e. Optionally include if TerminationTreatment parameter value is *VoiceMailRetrieval* or *VoiceMailStorage* to select the voice mail system.
- f. Include to identify the MS if different than MIN for call recording purposes.
- g. Include if modification to normal feature processing is required.
- h. Optional, for special routing purposes.
- i. Optional, if the TerminationTreatment value is *VoiceMailRetrieval* or *VoiceMailStorage*.
- j. Include if the TerminationTreatment value is *VoiceMailRetrieval* or *VoiceMailStorage* and the mailbox is not the MIN.
- k. Ignore unexpected parameters, if received.

6.5.2.77 LocationAreaID

The LocationAreaID (LOCID) parameter is used by the Serving MSC to specify the location area identity of an MS. The location area identity is a 16-bit number which identifies a specific location area within the group of cell sites indicated by the MSCID (Serving MSC). The LOCID is transferred to the VLR and to the HLR.

Field	Value	Type	Reference	Notes					
Identifier	LocationAreaID IMPLICIT OCTET STRING	M	6.5.1.2						
Length	2 octets	M	6.5.1.1						
Contents									
H	G	F	E	D	C	B	A	octet	Notes
MSB								1	
LocationAreaID								LSB	

Figure 85 LocationAreaID parameter

6.5.2.78 MessageWaitingNotificationCount

The MessageWaitingNotificationCount (MWNCOUNT) parameter carries the type and number of messages currently stored in the subscriber's mailbox(es).

The minimum length of this parameter is 2 octets.

Field	Value	Type	Reference	Notes					
Identifier	MessageWaitingNotificationCount IMPLICIT OCTET STRING	M	6.5.1.2						
Length	variable octets	M	6.5.1.1						
Contents									
H	G	F	E	D	C	B	A	octet	Notes
Type of Messages								1	a
Number of Messages Waiting								2	a
...								<i>n</i>	b

Figure 86 MessageWaitingNotificationCount parameter

Notes:

- These fields must occur in pairs and at least one pair must be included.
- There may be more occurrences of the octet pairs.

Table 147 MessageWaitingNotificationCount value

<i>Type of messages (octet 1)</i>										
Bits	H	G	F	E	D	C	B	A	Value	Meaning
	0	0	0	0	0	0	0	0	0	Voice messages.
	0	0	0	0	0	0	0	1	1	Short Message Service (SMS) messages.
	0	0	0	0	0	0	1	0	2	Group 3 (G3) Fax messages.
	0	0	0	0	0	0	1	1	3	} Reserved. Treat the same as value 255, <i>Not specified.</i>
				...					through	
	1	1	1	1	1	1	1	0	254	
	1	1	1	1	1	1	1	1	255	Type of messages not specified
<i>Number of Messages Waiting (octet 2)</i>										
Bits	H	G	F	E	D	C	B	A	Value	Meaning
	0	0	0	0	0	0	0	0	0	No messages are waiting.
	0	0	0	0	0	0	0	1	1	} Number of messages waiting.
				...					through	
	1	1	1	1	1	1	0	1	253	
	1	1	1	1	1	1	1	0	254	254 or more messages are waiting.
	1	1	1	1	1	1	1	1	255	Unknown. An unknown number of messages are waiting (greater than zero).

6.5.2.79 MessageWaitingNotificationType

The MessageWaitingNotificationType (MWNTYPE) parameter is used to convey the subscriber's to the serving system.

Field	Value	Type	Reference	Notes					
Identifier	MessageWaitingNotificationType IMPLICIT OCTET STRING	M	6.5.1.2						
Length	variable octets	M	6.5.1.1						
Contents									
H	G	F	E	D	C	B	A	octet	Notes
Reserved				MWI		APT	PT	1	a
...								<i>n</i>	<i>b</i>

Figure 87 MessageWaitingNotificationType parameter

Notes:

- a. Reserved bits shall be ignored on receipt and set to zero on sending.
- b. Ignore extra octets, if received. Send only defined (or significant) octets.

Table 148 MessageWaitingNotificationType value

<i>Pip Tone (PT) (octet 1, bit A)</i>											
Bits	H	G	F	E	D	C	B	A	Value	Meaning	
									0	0	Pip Tone (PT) notification is not authorized or no notification is required.
									1	1	Pip Tone (PT) notification is required.
<i>Alert Pip Tone (APT) (octet 1, bit B)</i>											
Bits	H	G	F	E	D	C	B	A	Value	Meaning	
									0	0	Alert Pip Tone (APT) notification is not authorized or notification is not required.
									1	1	Alert Pip Tone (APT) notification is required.
<i>Message Waiting Indication (MWI) (octet 1, bits C and D)</i>											
Bits	H	G	F	E	D	C	B	A	Value	Meaning	
					0	0			0	No MWI. Message Waiting Indication (MWI) notification is not authorized or notification is not required.	
					0	1			1	Reserved.	
					1	0			2	MWI On. Message Waiting Indication (MWI) notification is required. Messages waiting.	
					1	1			3	MWI Off. Message Waiting Indication (MWI) notification is required. No messages waiting.	

6.5.2.80 MobileDirectoryNumber

The MobileDirectoryNumber (MDN) parameter contains the MS's directory number, which may be different from its MIN.

Field	Value	Type	Reference	Notes					
Identifier	MobileDirectoryNumber IMPLICIT DigitsType	M	6.5.1.2	a					
Length	variable octets	M	6.5.1.1						
Contents									
H	G	F	E	D	C	B	A	octet	Notes
Type of Digits								1	b
Nature of Number								2	c
Numbering Plan				Encoding				3	d, e
Number of Digits								4	f
2 nd BCD Digit				1 st BCD Digit				5	
4 th BCD Digit				3 rd BCD Digit				6	
...				
n^{th} BCD Digit				$n-1^{\text{st}}$ BCD Digit				m	

Figure 88 MobileDirectoryNumber parameter for BCD digits

Notes:

- a. Refer to the DigitsType parameter type (see 6.5.3.2) for notes and field encoding.
- b. The Type of Digits field is ignored on receipt.
- c. The Nature of Number field is set to *National* or *International*.
- d. The Numbering Plan field is set to *Telephony Numbering*.
- e. The Encoding field is set to *BCD*.
- f. The Number of Digits is between 0 and at least 15.

6.5.2.81 MobileIdentificationNumber

The MobileIdentificationNumber (MIN) is a 10-digit representation of the MS's MIN, coded in BCD form.

Field	Value	Type	Reference	Notes					
Identifier	MobileIdentificationNumber IMPLICIT OCTET STRING	M	6.5.1.2						
Length	5 octets	M	6.5.1.1						
Contents									
H	G	F	E	D	C	B	A	octet	Notes
Digit 2				Digit 1				1	a
Digit 4				Digit 3				2	a
Digit 6				Digit 5				3	a
Digit 8				Digit 7				4	a
Digit 10				Digit 9				5	a

Figure 89 MobileIdentificationNumber parameter

Notes:

- a. Digit 1 is the most significant digit and Digit 10 is the least significant digit.

Table 149 MobileIdentificationNumber value

<i>Digit n, where n={0,1, 2, ..., 9} (octets 1-5)</i>									
Bits	H	G	F	E		Value	Meaning		
or	D	C	B	A					
	0	0	0	0		0	Digit = 0 or filler.		
	0	0	0	1		1	Digit = 1.		
	0	0	1	0		2	Digit = 2.		
	0	0	1	1		3	Digit = 3.		
	0	1	0	0		4	Digit = 4.		
	0	1	0	1		5	Digit = 5.		
	0	1	1	0		6	Digit = 6.		
	0	1	1	1		7	Digit = 7.		
	1	0	0	0		8	Digit = 8.		
	1	0	0	1		9	Digit = 9.		
	X	X	X	X		-	Other values reserved.		

6.5.2.82 MSCID

The MSCID parameter indicates the ID of the specified system.

Field	Value	Type	Reference	Notes					
Identifier	MSCID IMPLICIT OCTET STRING	M	6.5.1.2						
Length	3 octets	M	6.5.1.1						
Contents									
H	G	F	E	D	C	B	A	octet	Notes
MSB								1	a
MarketID								2	
Switch Number (SWNO)								3	b
LSB									

Figure 90 MSCID parameter

Notes:

- a. MarketID represent a unique market ID that is specified by the service provider (e.g., FCC assigned SID, CIBERNET assigned BID— see *TIA/EIA TSB29*).
- b. Switch Number represents a particular group of cell sites and switch resources associated with a common MarketID.

6.5.2.83 MSCIdentificationNumber

The MSCIdentificationNumber (MSCIN) parameter indicates the identification number of an MSC sending a message.

Field	Value	Type	Reference	Notes					
Identifier	MSCIdentificationNumber IMPLICIT DigitsType	M	6.5.1.2	a					
Length	variable octets	M	6.5.1.1						
Contents									
H	G	F	E	D	C	B	A	octet	Notes
Type of Digits								1	b
Nature of Number								2	c
Numbering Plan				Encoding				3	d, e
Number of Digits								4	f
2 nd BCD Digit				1 st BCD Digit				5	
4 th BCD Digit				3 rd BCD Digit				6	
...				
n^{th} BCD Digit				$n-1^{\text{st}}$ BCD Digit				m	

Figure 91 MSCIdentificationNumber parameter for BCD digits

Notes:

- a. Refer to the DigitsType parameter type (see 6.5.3.2) for notes and field encoding.
- b. The Type of Digits field is ignored on receipt.
- c. The Nature of Number field is set as applicable.
- d. The Numbering Plan field is set *as applicable*.
- e. The Encoding field is set to *BCD*.
- f. The Number of Digits is between 0 and at least 15.

6.5.2.84 MSLocation

The MSLocation (MSLOC) parameter provides the estimated location (latitude, longitude) of the MS with corresponding resolution.

The minimum length of this parameter is 7 octets.

Field	Value	Type	Reference	Notes						
Identifier	MSLocation IMPLICIT OCTET STRING	M	6.5.1.2							
Length	variable octets	M	6.5.1.1							
Contents										
H	G	F	E	D	C	B	A	octet	Notes	
Sign	MSB						Latitude in tenths of a second		1	a
									2	
							LSB		3	
Sign	MSB						Longitude in tenths of a second		4	a
									5	
							LSB		6	
MSB							Resolution in units of 1 foot		7	b
									LSB	8
							...		n	c

Figure 92 MSLocation parameter

Notes:

- a. The latitude and longitude fields are signed integers specifying the estimated MS location in units of tenths of a second. The range of latitude is $\pm 3,240,000$ seconds; the range of longitude is $\pm 6,480,000$ seconds. A positive latitude implies North latitude; a positive longitude implies West longitude. A negative value is represented by taking the 2's complement of the corresponding positive value.
- b. The resolution field specifies the resolution of the latitude and longitude location measurement. It is expressed in 1 foot increments for a 90 percent certainty that the MS is within a circle of resolution radius centered at latitude and longitude. A value of 65,535 indicates that the resolution is worse than 65,535 feet. Note that the second octet of this field is optional.
- c. Ignore extra octets, if received. Send only defined (or significant) octets.

6.5.2.85 NAMPSCallMode

The NAMPSCallMode (NAMPSMODE) parameter identifies certain characteristics of a dual-mode AMPS and NAMPS MS.

Field	Value	Type	Reference	Notes					
Identifier	NAMPSCallMode IMPLICIT OCTET STRING	M	6.5.1.2						
Length	variable octets	M	6.5.1.1						
Contents									
H	G	F	E	D	C	B	A	octet	Notes
Reserved						Call Mode		1	a
...								<i>n</i>	b

Figure 93 NAMPSCallMode parameter

Notes:

- a. Reserved bits shall be ignored on receipt and set to zero on sending.
- b. Ignore extra octets, if received. Send only defined (or significant) octets.

Table 150 NAMPSCallMode value

<i>Call Mode (octet 1, bits A and B)</i>											
Bits	H	G	F	E	D	C	B	A	Value	Meaning	
									0	-	NAMPS channel not acceptable.
									1	-	NAMPS channel acceptable.
								0	-	AMPS channel not acceptable.	
								1	-	AMPS channel acceptable.	

6.5.2.86 NAMPSChannelData

The NAMPSChannelData (NCHDATA) parameter is used to indicate Narrow Analog options related to the associated ChannelData (CHDATA) parameter. Other Narrow Analog ChannelData parameter values (i.e., CHNO, VMAC, etc.) are in accordance with AMPS, analog TDMA, NAMPS, and analog CDMA.

Field	Value	Type	Reference	Notes					
Identifier	NAMPSChannelData IMPLICIT OCTET STRING	M	6.5.1.2						
Length	variable octets	M	6.5.1.1						
Contents									
	–								
H	G	F	E	D	C	B	A	octet	Notes
Reserved			CC Indicator			NAVCA		1	a
...								<i>n</i>	b

Figure 94 NAMPSChannelData parameter

Notes:

- a. Reserved bits shall be ignored on receipt and set to zero on sending.
- b. Ignore extra octets, if received. Send only defined (or significant) octets.

Table 151 NAMPSChannelData value

<i>Narrow Analog Voice Channel Assignment (octet 1, bits A and B)</i>										
Bits	H	G	F	E	D	C	B	A	Value	Meaning
							0	0	-	Wide. 30 kHz AMPS voice channel.
							0	1	-	Upper. 10 kHz NAMPS voice channel.
							1	0	-	Middle. 10 kHz NAMPS voice channel.
							1	1	-	Lower. 10 kHz NAMPS voice channel.
<i>Color Code Indicator (CCIndicator) (octet 1, bits C, D, and E)</i>										
Bits	H	G	F	E	D	C	B	A	Value	Meaning
				0	0	0			-	ChannelData parameter SCC field applies.
				0	0	1			-	Digital SAT Color Code 1 (ignore SCC field).
				0	1	0			-	Digital SAT Color Code 2 (ignore SCC field).
				0	1	1			-	Digital SAT Color Code 3 (ignore SCC field).
				1	0	0			-	Digital SAT Color Code 4 (ignore SCC field).
				1	0	1			-	Digital SAT Color Code 5 (ignore SCC field).
				1	1	0			-	Digital SAT Color Code 6 (ignore SCC field).
				1	1	1			-	Digital SAT Color Code 7 (ignore SCC field).

6.5.2.87 NoAnswerTime

The NoAnswerTime (NATIME) parameter is used to indicate how long, in seconds, to wait after alerting an MS or after seizing an outgoing trunk before “No Answer” treatment is applied. This value overrides the receiving system’s default *No Answer Time* value.

Field	Value	Type	Reference	Notes					
Identifier	NoAnswerTime IMPLICIT OCTET STRING	M	6.5.1.2						
Length	variable octets	M	6.5.1.1						
Contents									
H	G	F	E	D	C	B	A	octet	Notes
Time								1	
...								<i>n</i>	<i>a</i>

Figure 95 NoAnswerTime parameter

Notes:

- a. Ignore extra octets, if received. Send only defined (or significant) octets.

Table 152 NoAnswerTime value

<i>Time (octet 1)</i>										
Bits	H	G	F	E	D	C	B	A	Value	Meaning
	0	0	0	0	0	0	0	0	0	} The number of seconds to wait after alerting an MS or after seizing an outgoing trunk before applying “no answer” trigger treatment.
				...					through	
	1	1	1	1	1	1	1	1	255	

6.5.2.88 OneTimeFeatureIndicator

The OneTimeFeatureIndicator (OTFI) parameter defines the modifications to feature processing that are in effect for a designated MS until the time of the next call release by the MS.

Field	Value	Type	Reference	Notes					
Identifier	OneTimeFeatureIndicator IMPLICIT OCTET STRING	M	6.5.1.2						
Length	variable octets	M	6.5.1.1						
Contents									
H	G	F	E	D	C	B	A	octet	Notes
CNIR		MWN		CWIC		CWFI		1	a
Reserved				Flash		PACA		2	b
...								<i>n</i>	<i>c</i>

Figure 96 OneTimeFeatureIndicator parameter

Notes:

- The CNIR and PACA indicators have no meaning when the OTFI is sent in the RoutingRequest INVOKE (i.e., for terminations).
- Reserved bits shall be ignored on receipt and set to zero on sending.
- Ignore extra octets, if received. Send only defined (or significant) octets.

Table 153 OneTimeFeatureIndicator value

<i>Call Waiting for Future Incoming Call (CWFI) (octet 1, bits A and B)</i>										
Bits	H	G	F	E	D	C	B	A	Value	Meaning
							0	0	0	Ignore. Ignore this indicator (use subscriber's profile).
							0	1	1	No CW. Call Waiting is turned off. (If this call is answered, Call Waiting should not be applied for future incoming calls.)
						1	0		2	Normal CW. Call Waiting is turned on. (If this call is answered, Call Waiting may be applied for future incoming calls requesting <i>Normal CW</i> or <i>Priority CW</i> .)
						1	1		3	Priority CW. (If the call is answered Call Waiting may be applied for future incoming calls requesting <i>Priority CW</i>).
<i>Call Waiting for Incoming Call (CWIC) (octet 1, bits C and D)</i>										
Bits	H	G	F	E	D	C	B	A	Value	Meaning
					0	0			0	Ignore. Ignore this indicator (treat the same as value 2, <i>Normal Call Waiting</i>).
					0	1			1	No CW. Call Waiting is not requested.
					1	0			2	Normal CW. Normal Call Waiting is requested.
					1	1			3	Priority CW. Priority Call Waiting is requested.

Table 153 (concluded)

<i>Message Waiting Notification (MWN) (octet 1, bits E and F)</i>										
Bits	H	G	F	E	D	C	B	A	Value	Meaning
			0	0					0	Ignore. Ignore this indicator.
			0	1					1	Pip Tone Inactive. MWN Pip Tones are not active for this call.
			1	0					2	Pip Tone Active. MWN Pip Tones are active for this call.
			1	1					3	Reserved.
<i>Calling Number Identification Restriction (CNIR) (octet 1, bits G and H)</i>										
Bits	H	G	F	E	D	C	B	A	Value	Meaning
		0	0						0	Ignore. Ignore this indicator.
		0	1						1	CNIR Inactive. CNIR is not active for this call.
		1	0						2	CNIR Active. CNIR is active for this call.
		1	1						3	Reserved.
<i>Priority Access and Channel Assignment (PACA) (octet 2, bits A and B)</i>										
Bits	H	G	F	E	D	C	B	A	Value	Meaning
								0	0	Ignore. Ignore this indicator.
								0	1	PACA Demand Inactive. PACA is not demand activated.
								1	0	PACA Demand Activated. PACA is demand activated.
								1	1	Reserved.
<i>Flash Privileges (Flash) (octet 2, bits C and D)</i>										
Bits	H	G	F	E	D	C	B	A	Value	Meaning
					0	0			0	Ignore. Ignore this indicator.
					0	1			1	Flash Inactive. Flash privileges are de-activated for the remainder of this call. (If flash features, such as Three-Way Calling (3WC) or Call Transfer (CT), have already been invoked, the subscriber may continue his or her operation in progress. Flash features may not be invoked.)
					1	0			2	Flash Active. Normal flash privileges.
					1	1			3	Reserved.

6.5.2.89 OriginationIndicator

The OriginationIndicator (ORIGIND) parameter defines the type of calls the MS is allowed to originate.

Field	Value	Type	Reference	Notes					
Identifier	OriginationIndicator IMPLICIT Unsigned Enumerated	M	6.5.1.2						
Length	1 octet	M	6.5.1.1						
Contents									
H	G	F	E	D	C	B	A	octet	Notes
Allowed Call Types								1	a, b

Figure 97 OriginationIndicator parameter

Notes:

- For values 4, 5, and 8, the Digits (Destination) parameter (see 6.5.2.58) shall accompany the OriginationIndicator parameter and shall contain the selected leading digits or directory.
- Value 8, *Single directory number*, shall cause all originations to be treated as if this single number had been dialed, with exceptions (e.g., 3 digits for emergency call).

Table 154 OriginationIndicator value

<i>(octet 1)</i>										
Bits	H	G	F	E	D	C	B	A	Value	Meaning
	0	0	0	0	0	0	0	0	0	Not used.
	0	0	0	0	0	0	0	1	1	Prior agreement.
	0	0	0	0	0	0	1	0	2	Origination denied.
	0	0	0	0	0	0	1	1	3	Local calls only.
	0	0	0	0	0	1	0	0	4	Selected leading digits of directory number See Note (a) above.
	0	0	0	0	0	1	0	1	5	Selected leading digits of directory Number and local calls only See Note (a) above.
	0	0	0	0	0	1	1	0	6	National long distance (includes local calls and may include neighboring countries).
	0	0	0	0	0	1	1	1	7	International calls (includes national long distance and local calls).
	0	0	0	0	1	0	0	0	8	Single directory number See Notes (a) and (b) above.
	0	0	0	0	1	0	0	1	9	} Reserved. Treat the same as value 3, <i>Local calls only</i> .
	1	1	0	1	1	1	1	1	through 223	
	1	1	1	0	0	0	0	0	224	} Reserved for <i>TIA/EIA-41</i> protocol extension. If unknown, treat the same as value 3, <i>Local calls only</i> .
	1	1	1	1	1	1	1	1	through 255	

6.5.2.90 OriginationTriggers

The OriginationTriggers (ORIGTRIG) parameter defines the origination trigger points that are currently active for the subscriber.

Field	Value								Type	Reference	Notes
Identifier	OriginationTriggers IMPLICIT OCTET STRING								M	6.5.1.2	
Length	variable octets								M	6.5.1.1	
Contents											
H	G	F	E	D	C	B	A	octet	Notes		
RvtC	Unrec	WZ	Inf	OLATA	ILATA	Local	All	1			
Reserved			PA	DP	Pound	DS	Star	2	a		
7 digits	6 digits	5 digits	4 digits	3 digits	2 digits	1 digit	No digits	3			
15 digits	14 digits	13 digits	12 digits	11 digits	10 digits	9 digits	8 digits	4			
...								n	b		

Figure 98 OriginationTriggers parameter

Notes:

- a. Set reserved values to 0 when sending, and process other triggers before treating received reserved values the same as *All*.
- b. If unknown octets with bits set are received, process other triggers before treating the same as *All*. Send only defined (or significant) octets.

Table 155 OriginationTriggers value

<i>All Origination (All) (octet 1, bit A)</i>											
Bits	H	G	F	E	D	C	B	A	Value	Meaning	
									0	0	Trigger is not active.
									1	1	Launch an OriginationRequest for any call attempt. This overrides all other values.
<i>Local (octet 1, bit B)</i>											
Bits	H	G	F	E	D	C	B	A	Value	Meaning	
									0	0	Trigger is not active.
									1	1	Launch an OriginationRequest for any local call attempt.
<i>Intra-LATA Toll (ILATA) (octet 1, bit C)</i>											
Bits	H	G	F	E	D	C	B	A	Value	Meaning	
									0	0	Trigger is not active.
									1	1	Launch an OriginationRequest for any intra-LATA call attempt.

#

Table 155 OriginationTriggers value (continued)

<i>Inter-LATA Toll (OLATA) (octet 1, bit D)</i>										#	
Bits	H	G	F	E	D	C	B	A	Value	Meaning	#
					0				0	Trigger is not active.	#
					1				1	Launch an OriginationRequest for any inter-LATA toll call attempt.	#
<i>International (Int'l) (octet 1, bit E)</i>										#	
Bits	H	G	F	E	D	C	B	A	Value	Meaning	#
					0				0	Trigger is not active.	#
					1				1	Launch an OriginationRequest for any international call attempt.	#
<i>World Zone (WZ) (octet 1, bit F)</i>										#	
Bits	H	G	F	E	D	C	B	A	Value	Meaning	#
					0				0	Trigger is not active.	#
					1				1	Launch an OriginationRequest for any call attempt outside of the current World Zone (as defined in ITU-T Rec. E.164).	#
<i>Unrecognized Number (Unrec) (octet 1, bit G)</i>										#	
Bits	H	G	F	E	D	C	B	A	Value	Meaning	#
									0	Trigger is not active.	#
									1	Launch an OriginationRequest for any call attempt to an unrecognized number.	#
<i>Revertive Call (RvtC) (octet 1, bit H)</i>										#	
Bits	H	G	F	E	D	C	B	A	Value	Meaning	#
									0	Trigger is not active.	#
									1	Launch an OriginationRequest for any Revertive Call attempt.	#
<i>Star (octet 2, bit A)</i>										#	
Bits	H	G	F	E	D	C	B	A	Value	Meaning	#
									0	Trigger is not active.	#
									1	Launch an OriginationRequest for any number beginning with a Star '*' digit.	#
<i>Double Star (DS) (octet 2, bit B)</i>										#	
Bits	H	G	F	E	D	C	B	A	Value	Meaning	#
									0	Trigger is not active.	#
									1	Launch an OriginationRequest for any number beginning with two Star '**' digits.	#
<i>Pound (octet 2, bit C)</i>										#	
Bits	H	G	F	E	D	C	B	A	Value	Meaning	#
									0	Trigger is not active.	#
									1	Launch an OriginationRequest for any number beginning with a Pound '#' digit.	#

Table 155 (continued)

Double Pound (DP) (octet 2, bit D)

Bits	H	G	F	E	D	C	B	A	Value	Meaning
					0				0	Trigger is not active.
					1				1	Launch an OriginationRequest for any number beginning with two Pound #'s digits.

Prior Agreement (PA) (octet 2, bit E)

Bits	H	G	F	E	D	C	B	A	Value	Meaning
				0					0	Trigger is not active.
				1					1	Launch an OriginationRequest for any number matching a criteria of a prior agreement.

No digits (octet 3, bit A)

Bits	H	G	F	E	D	C	B	A	Value	Meaning
								0	0	Trigger is not active.
								1	1	Launch an OriginationRequest for any call attempt with no digits.

1 digit (octet 3, bit B)

Bits	H	G	F	E	D	C	B	A	Value	Meaning
								0	0	Trigger is not active.
								1	1	Launch an OriginationRequest for any call attempt with 1 digit.

2 digits (octet 3, bit C)

Bits	H	G	F	E	D	C	B	A	Value	Meaning
						0			0	Trigger is not active.
						1			1	Launch an OriginationRequest for any call attempt with 2 digits.

3 digits (octet 3, bit D)

Bits	H	G	F	E	D	C	B	A	Value	Meaning
								0	0	Trigger is not active.
								1	1	Launch an OriginationRequest for any call attempt with 3 digits.

4 digits (octet 3, bit E)

Bits	H	G	F	E	D	C	B	A	Value	Meaning
				0					0	Trigger is not active.
				1					1	Launch an OriginationRequest for any call attempt with 4 digits.

5 digits (octet 3, bit F)

Bits	H	G	F	E	D	C	B	A	Value	Meaning
			0						0	Trigger is not active.
			1						1	Launch an OriginationRequest for any call attempt with 5 digits.

Table 155 (continued)

<i>6 digits (octet 3, bit G)</i>										
Bits	H	G	F	E	D	C	B	A	Value	Meaning
		0							0	Trigger is not active.
		1							1	Launch an OriginationRequest for any call attempt with 6 digits.
<i>7 digits (octet 3, bit H)</i>										
Bits	H	G	F	E	D	C	B	A	Value	Meaning
		0							0	Trigger is not active.
		1							1	Launch an OriginationRequest for any call attempt with 7 digits.
<i>8 digits (octet 4, bit A)</i>										
Bits	H	G	F	E	D	C	B	A	Value	Meaning
								0	0	Trigger is not active.
								1	1	Launch an OriginationRequest for any call attempt with 8 digits.
<i>9 digits (octet 4, bit B)</i>										
Bits	H	G	F	E	D	C	B	A	Value	Meaning
								0	0	Trigger is not active.
								1	1	Launch an OriginationRequest for any call attempt with 9 digits.
<i>10 digits (octet 4, bit C)</i>										
Bits	H	G	F	E	D	C	B	A	Value	Meaning
						0			0	Trigger is not active.
						1			1	Launch an OriginationRequest for any call attempt with 10 digits.
<i>11 digits (octet 4, bit D)</i>										
Bits	H	G	F	E	D	C	B	A	Value	Meaning
					0				0	Trigger is not active.
					1				1	Launch an OriginationRequest for any call attempt with 11 digits.
<i>12 digits (octet 4, bit E)</i>										
Bits	H	G	F	E	D	C	B	A	Value	Meaning
				0					0	Trigger is not active.
				1					1	Launch an OriginationRequest for any call attempt with 12 digits.
<i>13 digits (octet 4, bit F)</i>										
Bits	H	G	F	E	D	C	B	A	Value	Meaning
			0						0	Trigger is not active.
			1						1	Launch an OriginationRequest for any call attempt with 13 digits.

Table 155 (concluded)*14 digits (octet 4, bit G)*

Bits	H	G	F	E	D	C	B	A	Value	Meaning
		0							0	Trigger is not active.
		1							1	Launch an OriginationRequest for any call attempt with 14 digits.

15 digits or more (octet 4, bit H)

Bits	H	G	F	E	D	C	B	A	Value	Meaning
		0							0	Trigger is not active.
		1							1	Launch an OriginationRequest for any call attempt with 15 or more digits.

6.5.2.91 PACAIndicator

The PACAIndicator (PACAIND) parameter indicates the Priority Access and Channel Assignment (PACA) permanent activation status and priority level assigned to the subscriber. If the parameter is included, the subscriber is authorized for the indicated level.

Field	Value	Type	Reference	Notes					
Identifier	PACAIndicator IMPLICIT OCTET STRING	M	6.5.1.2						
Length	variable octets	M	6.5.1.1						
Contents									
H	G	F	E	D	C	B	A	octet	Notes
Reserved			PACA Level				PA	1	a
			...					<i>n</i>	b

Figure 99 PACAIndicator parameter

Notes:

- a. Reserved bits shall be ignored on receipt and set to zero on sending.
- b. Ignore extra octets, if received. Send only defined (or significant) octets.

Table 156 PACAIndicator value

<i>Permanent Activation (PA) (octet 1, bit A)</i>										
Bits	H	G	F	E	D	C	B	A	Value	Meaning
								0	-	PACA is not permanently activated.
								1	-	PACA is permanently activated.
<i>PACA Level (octet 1, bits B-E)</i>										
Bits	H	G	F	E	D	C	B	A	Value	Meaning
				0	0	0	0		0	Not used.
				0	0	0	1		1	Priority Level 1. This is the highest level.
				0	0	1	0		2	Priority Level 2.
				0	0	1	1		3	Priority Level 3.
				0	1	0	0		4	Priority Level 4.
				0	1	0	1		5	Priority Level 5.
				0	1	1	0		6	Priority Level 6.
				0	1	1	1		7	Priority Level 7.
				1	0	0	0		8	Priority Level 8.
				1	0	0	1		9	Priority Level 9.
				1	0	1	0		10	Priority Level 10.
				1	0	1	1		11	Priority Level 11.
				1	1	0	0		12	Priority Level 12.
				1	1	0	1		13	Priority Level 13.
				1	1	1	0		14	Priority Level 14.
				1	1	1	1		15	Priority Level 15.

6.5.2.92 PageIndicator

The PageIndicator (PAGEIND) parameter is used to indicate if paging should occur or if the system should only listen for a page response.

Field	Value	Type	Reference	Notes					
Identifier	PageIndicator IMPLICIT OCTET STRING	M	6.5.1.2						
Length	variable octets	M	6.5.1.1						
Contents									
H	G	F	E	D	C	B	A	octet	Notes
PageIndicator								1	
...								<i>n</i>	<i>a</i>

Figure 100 PageIndicator parameter

Notes:

- a. Ignore extra octets, if received. Send only defined (or significant) octets.

Table 157 PageIndicator value

<i>PageIndicator (octet 1)</i>										
Bits	H	G	F	E	D	C	B	A	Value	Meaning
	0	0	0	0	0	0	0	0	0	Not used.
	0	0	0	0	0	0	0	1	1	Page.
	0	0	0	0	0	0	1	0	2	Listen only.
	0	0	0	0	0	0	1	1	3	} Reserved. Treat the same as value 1, <i>Page</i> .
	...								through	
	1	1	0	1	1	1	1	1	223	
	1	1	1	0	0	0	0	0	224	} Reserved for <i>TIA/EIA-41</i> protocol extension. If unknown, treat the same as value 1, <i>Page</i> .
	...								through	
	1	1	1	1	1	1	1	1	255	

6.5.2.93 PC_SSN

The PC_SSN parameter carries the SS7 Point Code (PC) and Subsystem Number (SSN) of a particular cellular functional entity. Type indicates the type of functional entity (e.g., HLR, VLR, MSC). Used for subsequent routing by the application and takes precedence over lower layer addressing. The Point Code may represent a single entity or an alias for mated pair entities.

Field	Value	Type	Reference	Notes					
Identifier	PC_SSN IMPLICIT OCTET STRING	M	6.5.1.2						
Length	5 octets	M	6.5.1.1						
Contents									
H	G	F	E	D	C	B	A	octet	Notes
Type								1	
Point Code								2	a, b
								3	
								4	
Subsystem Number (SSN)								5	a

Figure 101 PC_SSN parameter

Notes:

- a. See 5.1.2.
- b. The content of this field is as follows.

• ANSI

Point Code - Member Number	2
Point Code - Cluster Number	3
Point Code - Network Number	4

• TTC

Point Code	2
	3
Not used (all'0')	4

(Format of TTC-PC)

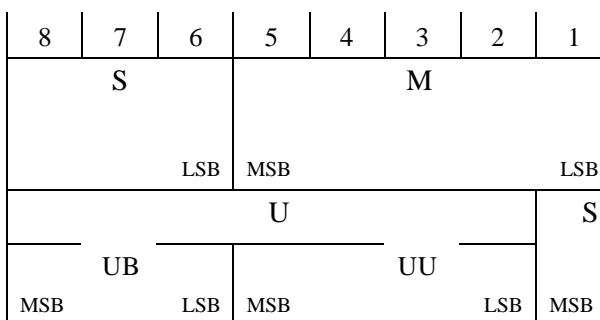

Table 158 PC_SSN value

<i>Type (octet 1)</i>										
Bits	H	G	F	E	D	C	B	A	Value	Meaning
	0	0	0	0	0	0	0	0	0	Not specified.
	0	0	0	0	0	0	0	1	1	Serving MSC.
	0	0	0	0	0	0	1	0	2	Home MSC.
	0	0	0	0	0	0	1	1	3	Gateway MSC.
	0	0	0	0	0	1	0	0	4	HLR.
	0	0	0	0	0	1	0	1	5	VLR.
	0	0	0	0	0	1	1	0	6	EIR (reserved).
	0	0	0	0	0	1	1	1	7	AC.
	0	0	0	0	1	0	0	0	8	Border MSC.
	0	0	0	0	1	0	0	1	9	Originating MSC.
	0	0	0	0	1	0	1	0	10	} Reserved. Treat the same as value 0, <i>Not specified.</i>
				...					through	
	1	1	0	1	1	1	1	1	223	
	1	1	1	0	0	0	0	0	224	} Reserved for <i>TIA/EIA-41</i> protocol extension. If unknown, treat the same as value 0, <i>Not specified.</i>
				...					through	
	1	1	1	1	1	1	1	1	255	

6.5.2.94 PilotBillingID

The PilotBillingID (PILOTBID) parameter is initially assigned at the first Originating MSC for incoming calls. The PilotBillingID is transferred, as required, to each system involved in an intersystem operation when multileg calls are handled. This ID is primarily intended for billing record correlation, but may be used for other purposes such as identifying the originating call, etc.

Field	Value	Type	Reference	Notes					
Identifier	PilotBillingID IMPLICIT OCTET STRING	M	6.5.1.2						
Length	7 octets	M	6.5.1.1						
Contents									
H	G	F	E	D	C	B	A	octet	Notes
MSB First Originating MarketID								1	a
LSB								2	
First Originating Switch Number								3	a
MSB ID Number								4	b
LSB								5	
LSB								6	
Segment Counter								7	

Figure 102 PilotBillingID parameter

Notes:

- Refer to the MSCID parameter (see 6.5.2.82) for the definition of these fields.
- is a unique number assigned by the functional entity identified in the MarketID and Switch Number fields (see *DMH*).

Table 159 PilotBillingID value

Segment Counter (octet 7)										
Bits	H	G	F	E	D	C	B	A	Value	Meaning
	0	0	0	0	0	0	0	0	0	} Number of call segments (see <i>DMH</i>)
	0	1	1	1	1	1	1	1	127	
	1	X	X	X	X	X	X	X	-	Bit H is intended for recording use following call disconnect and will always be 0 in <i>TIA/EIA-41</i> messages, except value 255, <i>Unspecified</i> .
	1	1	1	1	1	1	1	1	255	Unspecified The number of segments is unknown.

6.5.2.95 PilotNumber

The PilotNumber (PILOT) parameter contains the Pilot Directory Number for a multileg call.

Field	Value	Type	Reference	Notes					
Identifier	PilotNumber IMPLICIT DigitsType	M	6.5.1.2	a					
Length	variable octets	M	6.5.1.1						
Contents									
H	G	F	E	D	C	B	A	octet	Notes
Type of Digits								1	b
Nature of Number								2	c
Numbering Plan				Encoding				3	d, e
Number of Digits								4	f
2 nd BCD Digit				1 st BCD Digit				5	
4 th BCD Digit				3 rd BCD Digit				6	
...				
n^{th} BCD Digit				$n-1^{\text{st}}$ BCD Digit				m	

Figure 103 PilotNumber parameter for BCD digits

Notes:

- a. Refer to the DigitsType parameter type (see 6.5.3.2) for notes and field encoding.
- b. The Type of Digits field is ignored on receipt.
- c. The Nature of Number field is set to *National* or *International*.
- d. The Numbering Plan field is set to *Telephony Numbering*.
- e. The Encoding field is set to *BCD*.
- f. The Number of Digits is between 0 and at least 15.

6.5.2.96 PreferredLanguageIndicator

The PreferredLanguageIndicator (PLIND) parameter indicates the Preferred Language feature activity status and language associated with the subscriber.

Field	Value	Type	Reference	Notes					
Identifier	PreferredLanguageIndicator IMPLICIT OCTET STRING	M	6.5.1.2						
Length	variable octets	M	6.5.1.1						
Contents									
H	G	F	E	D	C	B	A	octet	Notes
Preferred Language								1	
...								<i>n</i>	<i>a</i>

Figure 104 PreferredLanguageIndicator parameter

Notes:

- a. Ignore extra octets, if received. Send only defined (or significant) octets.

Table 160 PreferredLanguageIndicator value

<i>Preferred Language (octet 1)</i>										
Bits	H	G	F	E	D	C	B	A	Value	Meaning
	0	0	0	0	0	0	0	0	0	Unspecified.
	0	0	0	0	0	0	0	1	1	English.
	0	0	0	0	0	0	1	0	2	French.
	0	0	0	0	0	0	1	1	3	Spanish.
	0	0	0	0	0	1	0	0	4	German.
	0	0	0	0	0	1	0	1	5	Portuguese.
	0	0	0	0	0	1	1	0	6	} Reserved. Treat the same as value 0, <i>Unspecified.</i>
				...					through	
	1	1	1	1	1	1	1	1	255	

6.5.2.97 Profile

The Profile is a collection of the subscriber's calling profile information. This information is a list of optional parameters. The Profile macro has been defined solely for editorial convenience, and does not affect the encoding in any way.

PROFILE			
	Type	Reference	Notes
Contents			
AuthenticationCapability	O	6.5.2.8	a
ChargingAreaInformation	O	6.5.2.J1	J1
CallingFeaturesIndicator	O	6.5.2.20	b
CarrierIdentificationCode	O	6.5.2.J2	J1
CarrierDigits	O	6.5.2.28	c
DMH_AccountCodeDigits	O	6.5.2.59	d
DMH_AlternateBillingDigits	O	6.5.2.60	d
DMH_BillingDigits	O	6.5.2.61	d
GeographicAuthorization	O	6.5.2.68	e
MessageWaitingNotificationCount	O	6.5.2.78	f
MessageWaitingNotificationType	O	6.5.2.79	g
MobileAdditionalParty'sCategory3	O	6.5.2.J3	J1
MobileDirectoryNumber	O	6.5.2.80	d
OriginationIndicator	O	6.5.2.89	h
OriginationTriggers	O	6.5.2.90	i
PACAIndicator	O	6.5.2.91	j
PreferredLanguageIndicator	O	6.5.2.96	k
RestrictionDigits	O	6.5.2.113	l
RoutingDigits	O	6.5.2.114	m
SMS_OriginationRestrictions	O	6.5.2.136	n
SMS_TerminationRestrictions	O	6.5.2.138	o
SPINPIN	O	6.5.2.139	p
SPINTriggers	O	6.5.2.140	q
TerminationRestrictionCode	O	6.5.2.157	r
TerminationTriggers	O	6.5.2.159	s

Figure 105 Profile Macro

Notes:

- a. Include on *IS-41-C* or later.
- b. Include to identify feature authorization and activity.
- c. Include if preferred carrier is applicable and TransactionCapability supported.
- d. Include if available for recording purposes (see *DMH*).
- e. Include if available for certain authorization restricted areas.
- f. Include if MessageWaitingNotificationType is *Message Waiting Indication* and number of messages waiting is authorized.
- g. Include if Message Waiting Notification feature is active and a message is waiting.
- h. Include to indicate the type of calls allowed for origination service.
- i. Include to indicate OriginationRequest triggers.
- j. Include to identify the PACA feature.
Include to identify the Preferred Language feature.
- l. Include if originations are restricted to NDC-X1 ~ Xn and TransactionCapability supported.
- m. Include for special routing information.
- n. Include for MS originated Short Message Service.
- o. Include for MS terminated Short Message Service.
- p. Include if local SPINI operation supported.
- q. Include to indicate Subscriber PIN Intercept triggers.
- r. Include to indicate the type of call termination service.
- s. Include to indicate the RedirectionRequest or TransferToNumberRequest triggers.
- J1. Include for Interconnection charge billing system. *

6.5.2.98 PSTNTermination

The PSTNTermination (PSTNTERM) parameter is used to provide an MSC with routing information for calls which are to be terminated in the PSTN.

Field	Value	Type	Reference	Notes
Identifier	PSTNTermination IMPLICIT SET	M	6.5.1.2	
Length	variable	M	6.5.1.1	
Contents				
DestinationDigits		M	6.5.2.56	
CarrierDigits		O	6.5.2.28	a, b
ElectronicSerialNumber		O	6.5.2.63	c
LegInformation		O	6.5.2.75	d
MobileIdentificationNumber		O	6.5.2.81	c, e
RoutingDigits		O	6.5.2.114	b, e
TerminationTriggers		O	6.5.2.159	b, f
•••				g

Figure 106 PSTNTermination parameter

Notes:

- a. Optional, for inter-LATA call routing. #
- b. This parameter has precedence for this call leg over the parameters outside the TerminationList parameter or the subscriber profile.
- c. Optional, for recording purposes.
- d. Include if part of a multi leg call.
- e. Optional, for special routing purposes.
- f. Include to indicate processing for failed call attempts.
- g. Ignore unexpected parameters, if received.

6.5.2.99 QualificationInformationCode

The QualificationInformationCode (QUALCODE) parameter indicates the type of qualification required.

Field	Value	Type	Reference	Notes					
Identifier	QualificationInformationCode IMPLICIT Unsigned Enumerated	M	6.5.1.2						
Length	1 octet	M	6.5.1.1						
Contents									
H	G	F	E	D	C	B	A	octet	Notes
QualificationInformationCode								1	a

Figure 107 QualificationInformationCode parameter

Table 161 QualificationInformationCode value

<i>QualificationInformationCode (octet 1)</i>										
Bits	H	G	F	E	D	C	B	A	Value	Meaning
	0	0	0	0	0	0	0	0	0	Not used.
	0	0	0	0	0	0	0	1	1	No Information.
	0	0	0	0	0	0	1	0	2	Validation only.
	0	0	0	0	0	0	1	1	3	Validation and Profile.
	0	0	0	0	0	1	0	0	4	Profile only.
	0	0	0	0	0	1	0	1	5	} Reserved. Treat the same as value 3, <i>Validation and profile.</i>
				...					through	
	1	1	0	1	1	1	1	1	223	
	1	1	1	0	0	0	0	0	224	} Reserved for <i>TIA/EIA-41</i> protocol extension. If unknown, treat the same as value 3, <i>Validation and profile.</i>
				...					through	
	1	1	1	1	1	1	1	1	255	

6.5.2.100 RANDC

The RANDC parameter is used to indicate which Random Variable was used by an MS to compute Authentication Response. Values of the RANDC may be coordinated between systems so that the RANDC also indicates which MSC generated the random number variable.

Field	Value	Type	Reference	Notes					
Identifier	RANDC IMPLICIT OCTET STRING	M	6.5.1.2						
Length	variable octets	M	6.5.1.1						
Contents									
H	G	F	E	D	C	B	A	octet	Notes
RANDC								1	
...								<i>n</i>	a

Figure 108 RANDC parameter

Notes:

- a. Ignore extra octets, if received. Send only defined (or significant) octets.

Table 162 RANDC value

<i>RANDC (octet 1)</i>										
Bits	H	G	F	E	D	C	B	A	Value	Meaning
	0	0	0	0	0	0	0	0	0	} The 8 most significant bits of the 32-bit Random Variable used to compute the Authentication Response.
				...					through	
	1	1	1	1	1	1	1	1	255	

6.5.2.101 RandomVariable

The RandomVariable (RAND) parameter contains a 32-bit random number that is used as input to the CAVE algorithm for MS authentication, Signaling Message Encryption and digital channel Voice Privacy. The random number is chosen by the Serving MSC.

Field	Value	Type	Reference	Notes					
Identifier	RandomVariable IMPLICIT OCTET STRING	M	6.5.1.2						
Length	4 octets	M	6.5.1.1						
Contents									
H	G	F	E	D	C	B	A	octet	Notes
MSB RAND LSB								1	
								2	
								3	
								4	

Figure 109 RandomVariable parameter

6.5.2.102 RandomVariableBaseStation

The RandomVariableBaseStation (RANDBS) parameter contains a 32-bit random number that is used as input to the CAVE authentication algorithm for base station authentication. The random number is chosen independently by the MS during the process to update its SSD.

Field	Value	Type	Reference	Notes					
Identifier	RandomVariableBaseStation IMPLICIT OCTET STRING	M	6.5.1.2						
Length	4 octets	M	6.5.1.1						
Contents									
H	G	F	E	D	C	B	A	octet	Notes
MSB RANDBS LSB								1	
								2	
								3	
								4	

Figure 110 RandomVariableBaseStation parameter

6.5.2.103 RandomVariableSSD

The RandomVariableSSD (RANDSSD) parameter contains a 56-bit random number that is used as input to the CAVE algorithm for generating Shared Secret Data (SSD -A and SSD-B). The random number is chosen independently by the AC during the process to update the MS's SSD.

Field	Value	Type	Reference	Notes					
Identifier	RandomVariableSSD IMPLICIT OCTET STRING	M	6.5.1.2						
Length	7 octets	M	6.5.1.1						
Contents									
H	G	F	E	D	C	B	A	octet	Notes
MSB								1	
RANDSSD								2	
...								...	
LSB								7	

Figure 111 RandomVariableSSD parameter

6.5.2.104 RandomVariableUniqueChallenge

The RandomVariableUniqueChallenge (RANDU) parameter contains a 24-bit random number that is used as input to the CAVE algorithm for authenticating a specific MS. The random number is chosen independently by the AC or VLR whenever a unique challenge is prescribed by local AC or VLR authentication procedures.

Field	Value	Type	Reference	Notes					
Identifier	RandomVariableUniqueChallenge IMPLICIT OCTET STRING	M	6.5.1.2						
Length	3 octets	M	6.5.1.1						
Contents									
H	G	F	E	D	C	B	A	octet	Notes
MSB								1	
RANDU								2	
LSB								3	

Figure 112 RandomVariableUniqueChallenge parameter

6.5.2.105 RANDValidTime

The RANDValidTime (RANDVT) parameter is used to specify the period in minutes for which a received Random Variable (RAND) is valid.

Field	Value	Type	Reference	Notes					
Identifier	RANDValidTime IMPLICIT OCTET STRING	M	6.5.1.2						
Length	variable octets	M	6.5.1.1						
Contents									
H	G	F	E	D	C	B	A	octet	Notes
Period								1	
...								<i>n</i>	<i>a</i>

Figure 113 RANDValidTime parameter

Notes:

- a. Ignore extra octets, if received. Send only defined (or significant) octets.

Table 163 RANDValidTime value

<i>Period (octet 1)</i>										
Bits	H	G	F	E	D	C	B	A	Value	Meaning
	0	0	0	0	0	0	0	0	0	RAND shall not be stored.
	0	0	0	0	0	0	0	1	1	} Number of minutes the associated received RAND is to be used.
				...					through	
	1	1	1	1	1	1	1	1	255	

6.5.2.106 ReceivedSignalQuality

The ReceivedSignalQuality (RSIGQUAL) parameter is used to indicate the raw received signal strength of the transmission from an MS. This signal is encoded as *SignalQuality* (6.5.2.121) except that the received signal strength is not adjusted based on power levels or the Station Class Mark of the MS. This raw value may be used as input to certain Border Cell problem resolution algorithms.

Field	Value	Type	Reference	Notes					
Identifier	ReceivedSignalQuality IMPLICIT Unsigned Integer (0..255)	M	6.5.1.2						
Length	1 octet	M	6.5.1.1						
Contents									
H	G	F	E	D	C	B	A	octet	Notes
ReceivedSignalQuality								1	<i>a</i>

Figure 114 ReceivedSignalQuality parameter

Notes:

- a. This octet is encoded the same as octet 1 in the SignalQuality parameter (see 6.5.2.121).

6.5.2.107 RedirectingNumberDigits

The RedirectingNumberDigits (RNDGTS) parameter provides information identifying the last redirecting party sent from or to the telephone network.

Field	Value	Type	Reference	Notes					
Identifier	RedirectingNumberDigits IMPLICIT DigitsType	M	6.5.1.2	a					
Length	variable octets	M	6.5.1.1						
Contents									
H	G	F	E	D	C	B	A	octet	Notes
Type of Digits								1	b
Nature of Number								2	c
Numbering Plan				Encoding				3	d, e
Number of Digits								4	f
2 nd BCD Digit				1 st BCD Digit				5	
4 th BCD Digit				3 rd BCD Digit				6	
...				
n^{th} BCD Digit				$n-1^{\text{st}}$ BCD Digit				m	

Figure 115 RedirectingNumberDigits parameter for BCD digits

Notes:

- a. Refer to the DigitsType parameter type (see 6.5.3.2) for notes and field encoding.
- b. The Type of Digits field is ignored on receipt.
- c. The Nature of Number field is set as applicable.
- d. The Numbering Plan field is set to *Telephony Numbering*.
- e. The Encoding field is set to *BCD*.
- f. The Number of Digits is between 0 and at least 15.

6.5.2.108 RedirectingNumberString

The RedirectingNumberString (RNSTRING) parameter carries the identification of the last redirecting party to be displayed on the MS.

Field	Value	Type	Reference	Notes					
Identifier	RedirectingNumberString IMPLICIT DigitsType	M	6.5.1.2	a					
Length	variable octets	M	6.5.1.1						
Contents									
H	G	F	E	D	C	B	A	octet	Notes
Type of Digits								1	b
Nature of Number								2	c
Numbering Plan				Encoding				3	d, e
Number of Digits								4	f
1 st Character								5	
2 nd Character								6	
...								...	
Last Character								<i>n</i>	

Figure 116 RedirectingNumberString parameter for IA5 digits

Notes:

- a. Refer to the DigitsType parameter type (see 6.5.3.2) for notes and field encoding.
- b. The Type of Digits field is ignored on receipt.
- c. The Nature of Number field is set as applicable.
- d. The Numbering Plan field is set to *Telephony Numbering*.
- e. The Encoding field is set to *IA5*.
- f. The Number of Digits is between 0 and at least 15.

6.5.2.109 RedirectingSubaddress

The RedirectingSubaddress (RSUB) parameter identifies the subaddress of the redirecting party of a call.

Field	Value	Type	Reference	Notes					
Identifier	RedirectingSubaddress IMPLICIT Subaddress	M	6.5.1.2	a					
Length	variable octets	M	6.5.1.1						
Contents									
H	G	F	E	D	C	B	A	octet	Notes
1	Type of Subaddress			O/E	Reserved			1	
Subaddress ...								2	
								3	
								...	
								<i>n</i>	

Figure 117 RedirectingSubaddress parameter

Notes:

- a. Refer to the Subaddress parameter type (see 6.5.3.13) for notes and field encoding.

6.5.2.110 RedirectionReason

This parameter was named FeatureIdentifier prior to this revision of the Interim Standard.

The RedirectionReason (REDREASON) parameter indicates the reason for redirection.

Field	Value	Type	Reference	Notes					
Identifier	RedirectionReason IMPLICIT Unsigned Enumerated	M	6.5.1.2						
Length	1 octet	M	6.5.1.1						
Contents									
H	G	F	E	D	C	B	A	octet	Notes
Redirection Reason								1	

Figure 118 RedirectionReason parameter

Table 164 RedirectionReason value

<i>Redirection Reason (octet 1)</i>										
Bits	H	G	F	E	D	C	B	A	Value	Meaning
	0	0	0	0	0	0	0	0	0	Not used.
	0	0	0	0	0	0	0	1	1	Busy.
	0	0	0	0	0	0	1	0	2	No Answer.
	0	0	0	0	0	0	1	1	3	Unconditional.
	0	0	0	0	0	1	0	0	4	No Page Response.
	0	0	0	0	0	1	0	1	5	Unavailable.
	0	0	0	0	0	1	1	0	6	Unroutable. A routing failure occurred while attempting to complete the call.
	0	0	0	0	0	1	1	1	7	Call accepted.
	0	0	0	0	1	0	0	0	8	Call refused.
	0	0	0	0	1	0	0	1	9	} Reserved. Treat the same as value 2, <i>No Answer.</i>
				...					through	
	1	1	0	1	1	1	1	1	223	
	1	1	1	0	0	0	0	0	224	} Reserved for <i>TIA/EIA-41</i> protocol extension. If unknown, treat the same as value 2, <i>No Answer.</i>
				...					through	
	1	1	1	1	1	1	1	1	255	

6.5.2.111 ReleaseReason

The ReleaseReason (RELREASON) parameter is used to indicate the reason for requesting that allocated resources be released (i.e., via the invocation of the FacilitiesRelease operation).

Field	Value	Type	Reference	Notes					
Identifier	ReleaseReason IMPLICIT Unsigned Enumerated	M	6.5.1.2						
Length	1 octet	M	6.5.1.1						
Contents									
H	G	F	E	D	C	B	A	octet	Notes
ReleaseReason								1	a

Figure 119 ReleaseReason parameter

Table 165 ReleaseReason value

<i>ReleaseReason (octet 1)</i>										
Bits	H	G	F	E	D	C	B	A	Value	Meaning
	0	0	0	0	0	0	0	0	0	Unspecified.
	0	0	0	0	0	0	0	1	1	CallOverClearForward.
	0	0	0	0	0	0	1	0	2	CallOverClearBackward.
	0	0	0	0	0	0	1	1	3	HandoffSuccessful.
	0	0	0	0	1	0	0	0	4	HandoffAbort - call over.
	0	0	0	0	1	0	1	0	5	HandoffAbort - not received.
	0	0	0	0	1	1	0	0	6	AbnormalMobileTermination.
	0	0	0	0	1	1	1	1	7	AbnormalSwitchTermination.
	0	0	0	1	0	0	0	0	8	SpecialFeatureRelease.
	0	0	0	0	1	0	0	1	9	} Reserved. Treat the same as value 0, <i>Unspecified.</i>
				...					through	
	1	1	0	1	1	1	1	1	223	
	1	1	1	0	0	0	0	0	224	} Reserved for <i>TIA/EIA-41</i> protocol extension. If unknown, treat the same as value 0, <i>Unspecified.</i>
				...					through	
	1	1	1	1	1	1	1	1	255	

6.5.2.112 ReportType

The ReportType (RPTTYP) parameter indicates the type of authentication failure being reported by the Visited System (MSC or VLR) to the AC.

Field	Value	Type	Reference	Notes					
Identifier	ReportType IMPLICIT Unsigned Enumerated	M	6.5.1.2						
Length	1 octet	M	6.5.1.1						
Contents									
H	G	F	E	D	C	B	A	octet	Notes
ReportType								1	

Figure 120 ReportType parameter

Table 166 ReportType value

<i>ReportType (octet 1)</i>										
Bits	H	G	F	E	D	C	B	A	Value	Meaning
	0	0	0	0	0	0	0	0	0	Not used.
	0	0	0	0	0	0	0	1	1	Unspecified security violation.
	0	0	0	0	0	0	1	0	2	MIN/ESN mismatch.
	0	0	0	0	0	1	1	1	3	RANDC mismatch.
	0	0	0	0	0	1	0	0	4	Reserved (see <i>TSB51</i>).
	0	0	0	0	0	1	0	1	5	SSD Update failed.
	0	0	0	0	0	1	1	0	6	Reserved (see <i>TSB51</i>).
	0	0	0	0	0	1	1	1	7	COUNT mismatch.
	0	0	0	0	1	0	0	0	8	Reserved (see <i>TSB51</i>).
	0	0	0	0	1	0	0	1	9	Unique Challenge failed.
	0	0	0	0	1	0	1	0	10	Unsolicited Base Station Challenge.
	0	0	0	0	1	0	1	1	11	SSD Update no response.
	0	0	0	0	1	1	0	0	12	COUNT Update no response.
	0	0	0	0	1	1	0	1	13	Unique Challenge no response.
	0	0	0	0	1	1	1	0	14	AUTHR mismatch.
	0	0	0	0	1	1	1	1	15	TERMTYP mismatch.
	0	0	0	1	0	0	0	0	16	Missing authentication parameters.
	0	0	0	1	0	0	0	1	17	} Reserved. Treat the same as value 1, <i>Unspecified security violation.</i>
				...					through 223	
	1	1	0	1	1	1	1	1	224	} Reserved for <i>TIA/EIA-41</i> protocol extension. If unknown, treat the same as value 1, <i>Unspecified security violation.</i>
	1	1	1	0	0	0	0	0	through 255	
	1	1	1	1	1	1	1	1	255	

6.5.2.113 RestrictionDigits

The RestrictionDigits parameter specifies either the leading digits of the directory number or a full directory number for which call originations are allowed, as indicated in the OriginationIndicator parameter.

Field	Value	Type	Reference	Notes					
Identifier	RestrictionDigits IMPLICIT DigitsType	M	6.5.1.2	a					
Length	variable octets	M	6.5.1.1						
Contents									
H	G	F	E	D	C	B	A	octet	Notes
Type of Digits								1	b
Nature of Number								2	c
Numbering Plan				Encoding				3	d, e
Number of Digits								4	f
2 nd BCD Digit				1 st BCD Digit				5	
4 th BCD Digit				3 rd BCD Digit				6	
...				
n^{th} BCD Digit				$n-1^{\text{st}}$ BCD Digit				m	

Figure 121 RestrictionDigits parameter for BCD digits

Notes:

- a. Refer to the DigitsType parameter type (see 6.5.3.2) for notes and field encoding.
- b. Ignore the field Type of Digits on receipt.
- c. The Nature of Number field is set as applicable.
- d. The Numbering Plan field is set to *Telephony Numbering*.
- e. The Encoding field is set to *BCD*.
- f. The Number of Digits is either 6 or 10 in NANP.

#

6.5.2.114 RoutingDigits

The RoutingDigits (ROUTDGTS) parameter specifies special routing information. The DestinationDigits are used once the call is routed with the RoutingDigits as a second stage of outpulsing or as a ISUP Generic Address Parameter. The usage of the RoutingDigits parameter is determined by the receiving MSC and various bilateral agreements.

Field	Value	Type	Reference	Notes					
Identifier	RoutingDigits IMPLICIT DigitsType	M	6.5.1.2	a					
Length	variable octets	M	6.5.1.1						
Contents									
H	G	F	E	D	C	B	A	octet	Notes
Type of Digits								1	b
Nature of Number								2	c
Numbering Plan				Encoding				3	d, e
Number of Digits								4	f
2 nd BCD Digit				1 st BCD Digit				5	
4 th BCD Digit				3 rd BCD Digit				6	
...				
<i>n</i> th BCD Digit				<i>n</i> -1 st BCD Digit				<i>m</i>	

Figure 122 RoutingDigits parameter for BCD digits

Notes:

- a. Refer to the DigitsType parameter type (see 6.5.3.2) for notes and field encoding.
- b. The Type of Digits field is ignored on receipt.
- c. The Nature of Number field is set as applicable.
- d. The Numbering Plan field is set to *Telephony Numbering*.
- e. The Encoding field is set to *BCD*.
- f. The Number of Digits is between 0 and at least 15.

6.5.2.115 SeizureType

The SeizureType (SEIZTYP) parameter is used to identify a trunk test configuration (e.g., a loop-back).

Field	Value	Type	Reference	Notes					
Identifier	SeizureType IMPLICIT Unsigned Enumerated	M	6.5.1.2						
Length	1 octet	M	6.5.1.1						
Contents									
H	G	F	E	D	C	B	A	octet	Notes
SeizureType								1	

Figure 123 SeizureType parameter

Table 167 SeizureType parameter

<i>Seizure Type (octet 1)</i>										
Bits	H	G	F	E	D	C	B	A	Value	Meaning
	0	0	0	0	0	0	0	0	0	Unspecified.
	0	0	0	0	0	0	0	1	1	Loop-back. The destination switch is to set up a loop around connection back to the source switch.
	0	0	0	0	0	0	1	0	2	} Reserved. Treat the same as value 0, <i>Unspecified.</i>
	...							through		
	1	1	0	1	1	1	1	1	223	
	1	1	1	0	0	0	0	0	224	} Reserved for <i>TIA/EIA-41</i> protocol extension. If unknown, treat the same as value 0, <i>Unspecified.</i>
	...							through		
	1	1	1	1	1	1	1	1	255	

6.5.2.116 SenderIdentificationNumber

The SenderIdentificationNumber (SENDERIN) parameter indicates the identification number of the functional entity that is sending a message.

Field	Value	Type	Reference	Notes					
Identifier	SenderIdentificationNumber IMPLICIT DigitsType	M	6.5.1.2	a					
Length	variable octets	M	6.5.1.1						
Contents									
H	G	F	E	D	C	B	A	octet	Notes
Type of Digits								1	b
Nature of Number								2	c
Numbering Plan				Encoding				3	d, e
Number of Digits								4	f
2 nd BCD Digit				1 st BCD Digit				5	
4 th BCD Digit				3 rd BCD Digit				6	
...				
n^{th} BCD Digit				$n-1^{\text{st}}$ BCD Digit				m	

Figure 124 SenderIdentificationNumber parameter for BCD digits

Notes:

- a. Refer to the DigitsType parameter type (see 6.5.3.2) for notes and field encoding.
- b. The Type of Digits field is ignored on receipt.
- c. The Nature of Number field is set as applicable.
- d. The Numbering Plan field is set *as applicable*.
- e. The Encoding field is set to *BCD*.
- f. The Number of Digits is between 0 and at least 15.

6.5.2.117 ServingCellID

The ServingCellID (CELLID) parameter specifies the ID of the serving cell site to be used in this transaction.

Field	Value	Type	Reference	Notes					
Identifier	ServingCellID IMPLICIT OCTET STRING	M	6.5.1.2						
Length	2 octets	M	6.5.1.1						
Contents									
H	G	F	E	D	C	B	A	octet	Notes
MSB								1	
LSB								2	

Figure 125 ServingCellID parameter

6.5.2.118 SetupResult

The SetupResult (SETRESULT) parameter indicates whether the inter-system setup operation was successful or unsuccessful.

Field	Value	Type	Reference	Notes					
Identifier	SetupResult IMPLICIT OCTET STRING	M	6.5.1.2						
Length	variable octets	M	6.5.1.1						
Contents									
H	G	F	E	D	C	B	A	octet	Notes
Setup Result								1	
...								<i>n</i>	<i>a</i>

Figure 126 SetupResult parameter

Notes:

- a. Ignore extra octets, if received. Send only defined (or significant) octets.

Table 168 SetupResult value

Setup Result (octet 1)										
Bits	H	G	F	E	D	C	B	A	Value	Meaning
	0	0	0	0	0	0	0	0	0	Not used.
	0	0	0	0	0	0	0	1	1	Unsuccessful.
	0	0	0	0	0	0	1	0	2	Successful.
	0	0	0	0	0	0	1	1	3	} Reserved. Treat the same as value 1, <i>Unsuccessful.</i>
	...							through		
	1	1	1	1	1	1	1	1	255	

6.5.2.119 SharedSecretData

The SharedSecretData (SSD) parameter contains the SharedSecretData-A (SSD-A) used in authentication of an MS and SharedSecretData-B (SSD-B) used as a cryptovvariable in Voice Privacy and Signaling Message Encryption for an MS. SSD is computed only at the Authentication Center (AC) and at the MS since it is based on the secret subscriber authentication key (A-Key) shared only between the AC and the MS.

Field	Value	Type	Reference	Notes					
Identifier	SharedSecretData IMPLICIT OCTET STRING	M	6.5.1.2						
Length	16 octets	M	6.5.1.1						
Contents									
H	G	F	E	D	C	B	A	octet	Notes
MSB SharedSecretData-A (SSD-A) ...								1	
								2	
								...	
								8	
MSB SharedSecretData-B (SSD-B) ...								9	
								10	
								...	
								16	

Figure 127 SharedSecretData parameter

6.5.2.120 SignalingMessageEncryptionKey

The SignalingMessageEncryptionKey (SMEKEY) parameter contains the 64-bit key to be used for encryption of appropriate data fields within signaling messages sent in both directions by the voice or traffic channels. The SMEKEY is calculated using CAVE parameters in effect when the call is established and remains constant for the duration of the call.

The presence of this optional parameter indicates that Signaling Message Encryption is possible for this MS.

Field	Value	Type	Reference	Notes					
Identifier	SignalingMessageEncryptionKey IMPLICIT OCTET STRING	M	6.5.1.2						
Length	8 octets	M	6.5.1.1						
Contents									
H	G	F	E	D	C	B	A	octet	Notes
MSB SignalingMessageEncryptionKey (SMEKEY) ...								1	
								2	
								...	
								8	

Figure 128 SignalingMessageEncryptionKey parameter

6.5.2.121 SignalQuality

The SignalQuality (SIGQUAL) parameter is used to indicate to a requesting MSC, the relative received signal strength of an MS for which a location process has been performed.

Field	Value	Type	Reference	Notes					
Identifier	SignalQuality IMPLICIT Unsigned Integer (0..255)	M	6.5.1.2						
Length	1 octet	M	6.5.1.1						
Contents									
H	G	F	E	D	C	B	A	octet	Notes
SignalQuality								1	

Figure 129 SignalQuality parameter

Table 169 SignalQuality value

<i>SignalQuality (octet 1)</i>										
Bits	H	G	F	E	D	C	B	A	Value	Meaning
	0	0	0	0	0	0	0	0	0	Not a usable signal.
	0	0	0	0	0	0	0	1	1	} Reserved. Treat as <i>Not a usable signal</i> .
	0	0	0	0	0	0	0	0	8	
	0	0	0	0	1	0	0	0	9	
	0	0	0	0	1	0	0	1	9	} Usable signal range.
	1	1	1	1	0	1	0	1	245	
	1	1	1	1	0	1	1	0	246	
	1	1	1	1	0	1	1	0	246	} Reserved. Treat as <i>interference</i> .
	1	1	1	1	1	1	1	0	254	
	1	1	1	1	1	1	1	1	255	
	1	1	1	1	1	1	1	1	255	Interference.

The concept of the SignalQuality value for handoff purposes is summarized in the figure on the next page. Each cell site is assumed to be equipped with a scanning receiver capable of being tuned to any cellular channel and which contains circuitry that produces an output proportional to a characteristic of the received signal suitable for evaluating a proposed handoff operation. This output is then converted by means of appropriate A/D circuits to a digital value in a range with "reasonable" resolution. Values within this range shall be suitably adjusted with respect to the Candidate cell's power level, the maximum power level that an MS is allowed to transmit in the candidate cell, the MS maximum power level, the current MS power level (VMAC or DMAC) in the serving cell, and the power class indicated in the station class mark. The adjusted value shall then be linearly mapped onto the signal quality scale.

The following example illustrates how the received signal strength of an MS can be adjusted:

The current power level of the MS in the serving cell is subtracted from the maximum possible power level in the candidate cell. The result is multiplied by the difference in the Effective Radiated Power (ERP) between two consecutive levels. This value is then

added to the received signal strength. The result is the adjusted value that shall be mapped to the signal quality scale.

Note: The maximum possible power level of the MS in the candidate cell is the lesser of:

- the maximum transmit power level allowed in the candidate cell (this value may be obtained from an internal database of the serving system).
- the maximum power level corresponding to the power class of the MS.

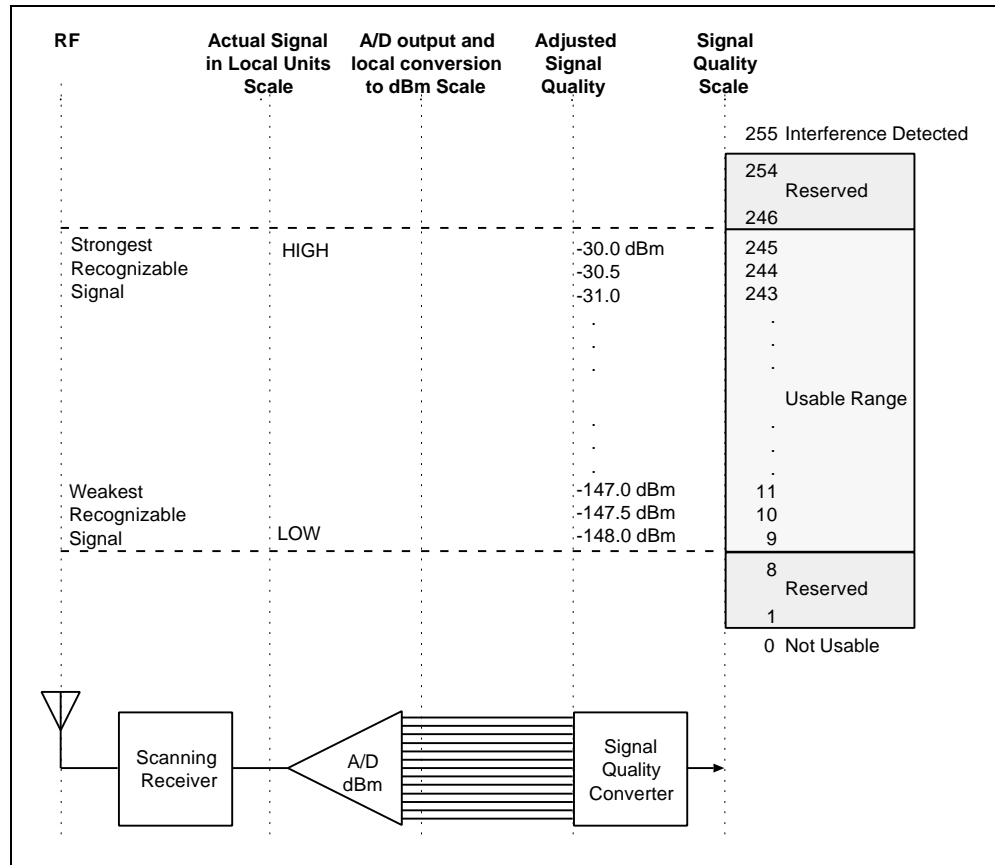

Figure 130 Definition of Signal Quality for Handoff

The scale labeled “ACTUAL SIGNAL IN LOCAL UNITS” represents the open ended range of signal characteristic in which the Scanning Receiver operates. The value marked “HIGH” corresponds to the maximum value at which saturation occurs in the Scanning Receiver circuits. The value marked “LOW” corresponds to the minimum usable signal for handoff purposes. It must be greater than or equal to the sensitivity rating of the base site receiver equipment.

The A/D output may have any range with a “reasonable” number of distinguishable values between those corresponding to the HIGH and LOW values of RF signal. Reasonable resolution will be defined at the “Signal Quality scale” reference point as 0.5 dBm with the weakest recognizable value, -148 dBm, defined as decimal (9) and the strongest recognizable value, -30 dBm, defined as decimal (245). The -148 to -30 dBm range with 0.5 dBm resolution requires 237 representative values. The octal encoding for decimal (9) to decimal (245) will be used to represent signal quality values between MSCs. Signal quality zero (0) is used to indicate an unusable signal (including an undetectable signal). The value 255 is used to indicate a case of known (or suspected) interference. Values (1-8) and (246-254) are reserved for future use.

6.5.2.122 SMS_AccessDeniedReason

The SMS_AccessDeniedReason (SMSACCDEN) parameter indicates why short message delivery is not currently allowed to an MS-based SME.

Field	Value	Type	Reference	Notes					
Identifier	SMS_AccessDeniedReason IMPLICIT OCTET STRING	M	6.5.1.2						
Length	variable octets	M	6.5.1.1						
Contents									
H	G	F	E	D	C	B	A	octet	Notes
SMS Access Denied Reason								1	
...								<i>n</i>	<i>a</i>

Figure 131 SMS_AccessDeniedReason parameter

Notes:

- a. Ignore extra octets, if received. Send only defined (or significant) octets.

Table 170 SMS Access Denied Reason value

<i>SMS Access Denied Reason (octet 1)</i>										
Bits	H	G	F	E	D	C	B	A	Value	Meaning
	0	0	0	0	0	0	0	0	0	Not used.
	0	0	0	0	0	0	0	1	1	Denied. The request cannot be honored, or the MS is unknown, or the addressed MS is known, but the addressed MS user has either not subscribed to SMS or the user's subscription has been suspended (e.g., subscriber vacation disconnect, non-payment disconnect). No notification shall be sent.
	0	0	0	0	0	0	1	0	2	Postponed. The addressed MS is known, but is currently unreachable (e.g., an MS-based SME is unreachable, the SME is not currently available, MS receiver is off, MS is busy, etc.) and SMSNotificationIndicator indicates <i>Notify when available</i> . Notification shall be sent.
	0	0	0	0	0	0	1	1	3	Unavailable. The addressed MS is known, but is currently unavailable (e.g., an MS-based SME is unreachable, the SME is not currently available, MS receiver is off, MS-based SME is busy, etc.) and SMSNotificationIndicator indicates <i>Do not notify when available</i> . No notification shall be sent.
	0	0	0	0	0	1	0	0	4	Invalid. The SMS_TeleserviceID is invalid. No notification shall be sent.
	0	0	0	0	0	1	0	1	5	} Reserved. Treat the same as value 1, <i>Denied</i> .
				...					through	
	0	0	1	1	1	1	1	1	63	} Reserved. Treat the same as value 2, <i>Postponed</i> .
	0	1	0	0	0	0	0	0	64	
				...					through	
	0	1	1	1	1	1	1	1	127	

Table 170 (concluded)

<i>SMS Access Denied Reason (octet 1)</i>										
Bits	H	G	F	E	D	C	B	A	Value	Meaning
	1	0	0	0	0	0	0	0	128	} Reserved. Treat the same as value 3, <i>Unavailable</i> .
				...					through	
	1	1	0	1	1	1	1	1	223	
	1	1	1	0	0	0	0	0	224	} Reserved for <i>TIA/EIA-41</i> protocol extension. If unknown, treat the same as value 3, <i>Unavailable</i> .
				...					through	
	1	1	1	1	1	1	1	1	255	

1
2
3
4
5
6
7
8
9
10
11
12
13
14
15
16
17
18
19
20
21
22
23
24
25
26
27
28
29
30
31
32
33
34
35
36
37
38
39
40
41
42
43
44
45
46
47
48
49
50
51
52
53
54
55
56
57
58
59
60

6.5.2.123 SMS_Address

The SMS_Address (SMSADDR) parameter is used to convey the current routing address of the Serving MSC for the purpose of short message termination to an MS-based SME.

Field	Value	Type	Reference	Notes					
Identifier	SMS_Address IMPLICIT DigitsType	M	6.5.1.2	a					
Length	variable octets	M	6.5.1.1						
Contents									
H	G	F	E	D	C	B	A	octet	Notes
Type of Digits								1	b
Nature of Number								2	c
Numbering Plan				Encoding				3	d, e
Number of Digits								4	f
2 nd BCD Digit				1 st BCD Digit				5	
4 th BCD Digit				3 rd BCD Digit				6	
...				
<i>n</i> th BCD Digit				<i>n</i> -1 st BCD Digit				<i>m</i>	

Figure 132 SMS_Address parameter for BCD digits

Notes:

- a. See the DigitsType parameter type (see 6.5.3.2) for notes and field encoding.
- b. Type of Digits is ignored on receipt.
- c. Nature of Number may be *National* or *International*.
- d. Numbering Plan supported shall include *E.164*, *X.121*, and *Private numbering plan* for this parameter variant.
- e. The encoding field shall always be set to *BCD* for this parameter variant.
- f. The Number of Digits ranges from 0 to at least 15.

Field	Value	Type	Reference	Notes					
Identifier	SMS_Address IMPLICIT DigitsType	M	6.5.1.2	a					
Length	variable octets	M	6.5.1.1						
Contents									
H	G	F	E	D	C	B	A	octet	Notes
Type of Digits								1	b
Nature of Number								2	c
Numbering Plan				Encoding				3	d, e
MSB								4	
IP Address								5	
								6	
LSB								7	

Figure 133 SMS_Address Encoding for an IP address

Notes:

- a. See the DigitsType parameter type (see 6.5.3.2) for notes and field encoding.
- b. Type of Digits is ignored on receipt.
- c. Nature of Number may be *National* or *International*.
- d. Numbering Plan shall be *IP* for this parameter variant.
- e. Encoding shall be *octet string* for this parameter variant.

Field	Value	Type	Reference	Notes					
Identifier	SMS_Address IMPLICIT DigitsType	M	6.5.1.2	a					
Length	variable octets	M	6.5.1.1						
Contents									
H	G	F	E	D	C	B	A	octet	Notes
Type of Digits								1	b
Nature of Number								2	c
Numbering Plan				Encoding				3	d, e
Point Code								4	f
								5	
								6	
Subsystem Number (SSN)								7	

Figure 134 SMS_Address parameter for an SS7 Point Code Address

Notes:

- a. See the DigitsType parameter type (see 6.5.3.2) for notes and field encoding.
- b. Type of Digits is ignored on receipt.
- c. Nature of Number may be *National* or *International*.
- d. Numbering Plan shall be *SS7* for this parameter variant.
- e. Encoding shall be *octet string* for this parameter variant.
- f. The content of this field is as follows.

• ANSI

Point Code - Member Number	2
Point Code - Cluster Number	3
Point Code - Network Number	4

• TTC

Point Code	2
	3
Not used (all'0')	4

(Format of TTC-PC)

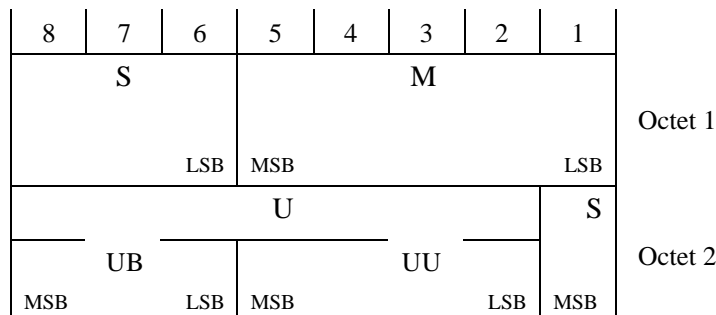

6.5.2.124 SMS_BearerData

The SMS_BearerData parameter is to be used and interpreted by an SMS teleservice.

Field	Value	Type	Reference	Notes					
Identifier	SMS_BearerData IMPLICIT OCTET STRING	M	6.5.1.2						
Length	variable octets	M	6.5.1.1						
Contents									
H	G	F	E	D	C	B	A	octet	Notes
SMS Bearer Data ...								1	a
								2	
								...	
								<i>n</i>	a, b

Figure 135 SMS_BearerData parameter

Notes:

- a. The formatting of the SMS Bearer Data is performed independently of this Standard. The formatting of the SMS Bearer Data is defined by a Teleservice specification.
- b. The size is approximately 200 octets for this Standard.

6.5.2.125 SMS_CauseCode

The SMS_CauseCode parameter indicates a reason for not delivering an SMS message.

Field	Value	Type	Reference	Notes					
Identifier	SMS_CauseCode IMPLICIT OCTET STRING	M	6.5.1.2						
Length	variable octets	M	6.5.1.1						
Contents									
H	G	F	E	D	C	B	A	octet	Notes
SMS Cause Code								1	a
...								<i>n</i>	b

Figure 136 SMS_CauseCode parameter

Notes:

- a. Only the SMS_CauseCode *SMS delivery postponed* is used to indicate that an SMS message is pending delivery and that notification shall be provided.
- b. Ignore extra octets, if received. Send only defined (or significant) octets.

Table 171 SMS_CauseCode value

SMS Cause Code (octet 1)

A. Network Problems:

Bits	H	G	F	E	D	C	B	A	Value	Meaning
	0	0	0	0	0	0	0	0	0	Address vacant. SMS Destination Address is valid but not currently allocated to an SMS terminal. The MIN associated with a valid destination address is not known to its HLR.
	0	0	0	0	0	0	0	1	1	Address translation failure. The SMS Destination Address is invalid (e.g., address is not a recognized address type, address is not for a known or possible SMS functional entity, the MIN associated with a destination MS address does not correspond to its HLR, the ESN associated with a destination MS does not match the expected value, the SMS_Destination-Address, SMS_OriginalDestinationAddress, destination MIN, or original destination subaddress does not match the address of a destination SME, etc.).
	0	0	0	0	0	0	1	0	2	Network resource shortage. Network transmission failed due to lack of a network resource or link capacity.
	0	0	0	0	0	0	1	1	3	Network failure. A network node failed, a link failed or a required operation failed.
	0	0	0	0	0	1	0	0	4	Invalid Teleservice ID. The SMS_TeleserviceIdentifier is not known, is not supported or is not authorized by an addressed functional entity.
	0	0	0	0	0	1	0	1	5	Other network problem. A network problem other than identified above.
	0	0	0	0	0	1	1	0	6	} Reserved. Treat the same as value 5, <i>Other network problem.</i>
	0	0	0	...	1	1	1	1	31	

Table 171 (continued)

SMS Cause Code (octet 1)										
B. Terminal Problems :										
Bits	H	G	F	E	D	C	B	A	Value	Meaning
	0	0	1	0	0	0	0	0	32	No Page response. The addressed MS-based SME is known, but it does not respond to a page. SMS Notification is not pending.
	0	0	1	0	0	0	0	1	33	Destination busy. The destination MS-based SME is SMS capable, but is currently engaged in a call, a service or a call mode that precludes the use of SMS or the destination SME is congested. This value shall only be used between the MSC and the MC when allowed by bilateral agreement. SMS Notification is not pending.
	0	0	1	0	0	0	1	0	34	No acknowledgment. The destination SME does not acknowledge receipt of the SMS delivery. This value may be used when <i>terminal busy</i> and <i>no page response</i> are not appropriate. SMS Notification is not pending.
	0	0	1	0	0	0	1	1	35	Destination resource shortage. A required terminal resource (e.g., memory, etc.) is not available to process this message. SMS notification is not pending.
	0	0	1	0	0	1	0	0	36	SMS delivery postponed. Delivery is not currently possible (e.g., <i>No page response</i> , <i>Destination busy</i> , <i>No acknowledgment</i> , <i>Destination out of service</i> , <i>Other terminal problem</i>), but SMS notification is pending.
	0	0	1	0	0	1	0	1	37	Destination out of service. The addressed destination is out of service for an extended period of time (e.g., MS sleep, inactive, power off). SMS notification is not pending.
	0	0	1	0	0	1	1	0	38	Destination no longer at this address. The MS-based SME is no longer at the temporary SMS routing address. The message sender should not re-use the temporary SMS routing address. SMS notification is not pending.
	0	0	1	0	0	1	1	1	39	Other terminal problem. A terminal problem other than described above. SMS notification is not pending.
	0	0	1	0	1	0	0	0	40	} Reserved. Treat the same as value 39, <i>Other terminal problems</i> .
				...					through	
	0	0	1	0	1	1	1	1	47	
	0	0	1	1	0	0	0	0	48	} Reserved. Treat the same as value 36, <i>SMS delivery postponed</i> .
				...					through	
	0	0	1	1	1	1	1	1	63	

Table 171 (continued)

SMS Cause Code (octet 1)

C. Radio Interface Problems :

Bits	H	G	F	E	D	C	B	A	Value	Meaning
	0	1	0	0	0	0	0	0	64	Radio interface resource shortage. There is no channel available or there is radio congestion at this time.
	0	1	0	0	0	0	0	1	65	Radio interface incompatibility. The MS for an MS-based SME is operating in a mode that does not support SMS at this time.
	0	1	0	0	0	0	1	0	66	Other radio interface problem. A radio interface problem to an MS-based SME other than described above.
	0	1	0	0	0	0	1	1	67	} Reserved. Treat the same as value 66, <i>Other radio interface problem</i>
				...					through	
	0	1	0	1	1	1	1	1	95	

1
2
3
4
5
6
7
8
9
10
11
12
13
14
15
16
17
18
19
20
21
22
23
24
25
26
27
28
29
30
31
32
33
34
35
36
37
38
39
40
41
42
43
44
45
46
47
48
49
50
51
52
53
54
55
56
57
58
59
60

Table 171 (concluded)

SMS Cause Code (octet 1)

D. General Problems :

Bits	H	G	F	E	D	C	B	A	Value	Meaning
	0	1	1	0	0	0	0	0	96	Encoding problem. The size of a parameter or field is not what is expected.
	0	1	1	0	0	0	0	1	97	SMS origination denied. The originating MIN is not recognized, the originating address is not allowed for the originating MIN, the ESN does not match the originating MIN, the origination is not authorized, the originating address is not recognized, etc.
	0	1	1	0	0	0	1	0	98	SMS termination denied. The destination is not authorized to receive the SMS message, the MC refused the message, the destination SME refused the message, the destination is not authorized for a required supplementary service, etc.
	0	1	1	0	0	0	1	1	99	Supplementary service not supported. The originating supplementary service is not known or supported, the sender is not authorized for an originating supplementary service, etc.
	0	1	1	0	0	1	0	0	100	SMS not supported. SMS is not supported by an addressed functional entity.
	0	1	1	0	0	1	0	1	101	Reserved.
	0	1	1	0	0	1	1	0	102	Missing expected parameter. An optional parameter that is required for a particular function).
	0	1	1	0	0	1	1	1	103	Missing mandatory parameter. A parameter is missing that is mandatory for a particular message.
	0	1	1	0	1	0	0	0	104	Unrecognized parameter value. A known parameter has a unknown or unsupported value.
	0	1	1	0	1	0	0	1	105	Unexpected parameter value. A known parameter has a known, but unexpected value.
	0	1	1	0	1	0	1	0	106	User Data size error. The User Data size is too large for access technology, transport network, or call mode, etc. The User Data size is not what is expected for the indicated teleservice.
	0	1	1	0	1	0	1	7	107	Other general problem.
	0	1	1	0	1	1	0	0	108	} Reserved. Treat the same as value 107, <i>Other general problems.</i>
				...					through	
	1	1	0	1	1	1	1	1	223	
	1	1	1	0	0	0	0	0	224	} Reserved for <i>TIA/EIA-41</i> protocol extension. If unknown, treat the same as value 107, <i>Other general problems.</i>
				...					through	
	1	1	1	1	1	1	1	1	255	

6.5.2.126 SMS_ChargeIndicator

The SMS_ChargeIndicator parameter is used to specify various charging options for an SMS message.

Field	Value	Type	Reference	Notes					
Identifier	SMS_ChargeIndicator IMPLICIT OCTET STRING	M	6.5.1.2						
Length	variable octets	M	6.5.1.1						
Contents									
H	G	F	E	D	C	B	A	octet	Notes
SMS Charge Indicator								1	
...								<i>n</i>	<i>a</i>

Figure 137 SMS_ChargeIndicator parameter

Notes:

- a. Ignore extra octets, if received. Send only defined (or significant) octets.

Table 172 SMS Charge Indicator values

SMS Charge Indicator (octet 1)										
Bits	H	G	F	E	D	C	B	A	Value	Meaning
	0	0	0	0	0	0	0	0	0	Not used.
	0	0	0	0	0	0	0	1	1	No charge.
	0	0	0	0	0	0	1	0	2	Charge original originator. Charge the original message originator, if allowed by the originator's profile.
	0	0	0	0	0	0	1	1	3	Charge Original destination. Charge the message destination, if allowed by the destination's profile.
	0	0	0	0	0	1	0	0	4	} Reserved. Treat the same as value 1, <i>No charge.</i>
				...					through 63	
	0	0	1	1	1	1	1	1	64	} Reserved. Treat the same as value 2, <i>Charge original originator.</i>
	0	1	0	0	0	0	0	0	through 127	
	1	0	0	0	0	0	0	0	128	} Reserved. Treat the same as value 3, <i>Charge original destination.</i>
	1	1	0	1	1	1	1	1	through 223	
	1	1	1	0	0	0	0	0	224	} Reserved for TIA/EIA-41 protocol extension. If unknown, treat the same as value 2, <i>Charge original originator.</i>
	1	1	1	1	1	1	1	1	through 255	

6.5.2.127 SMS_DestinationAddress

The SMS_DestinationAddress parameter conveys the address of a destination SME.

Field	Value	Type	Reference	Notes					
Identifier	SMS_DestinationAddress IMPLICIT DigitsType	M	6.5.1.2	a					
Length	variable octets	M	6.5.1.1						
Contents									
H	G	F	E	D	C	B	A	octet	Notes
Type of Digits								1	b
Nature of Number								2	c
Numbering Plan				Encoding				3	d, e
Number of Digits								4	f
2 nd BCD Digit				1 st BCD Digit				5	
4 th BCD Digit				3 rd BCD Digit				6	
...				
<i>n</i> th BCD Digit				<i>n</i> -1 st BCD Digit				<i>m</i>	

Figure 138 SMS_DestinationAddress parameter for BCD digits

Notes:

- a. See the DigitsType parameter type (see 6.5.3.2) for notes and field encoding.
- b. Type of Digits is ignored on receipt.
- c. Nature of Number may be *National* or *International*.
- d. Numbering Plan supported shall include *E.164*, *X.121*, and *Private numbering plan* for this parameter variant.
- e. The encoding field shall always be set to *BCD* for this parameter variant.
- f. The Number of Digits ranges from 0 to at least 15.

6.5.2.128 SMS_MessageCount

The) parameter is used to indicate the number of SMS messages pending delivery.

Field	Value	Type	Reference	Notes					
Identifier	SMS_MessageCount IMPLICIT OCTET STRING	O	6.5.1.2						
Length	variable octets	O	6.5.1.1						
Contents									
H	G	F	E	D	C	B	A	octet	Notes
SMS Message Count								1	a
...								<i>n</i>	b

Figure 140 SMS_MessageCount parameter

Notes:

- a. A value of 0 (zero) indicates .
- b. Ignore extra octets, if received. Send only defined (or significant) octets.

6.5.2.129 SMS_MessageWaitingIndicator

The) parameter prompts the Serving MSC and the HLR to be prepared to launch an SMSNotification, when the MS (in the case of an MS-based recipient SME) becomes available.

Field	Value	Type	Reference	Notes
Identifier	SMS_MessageWaitingIndicator IMPLICIT NULL	M	6.5.1.2	
Length	zero octets	M	6.5.1.1	
Contents				

Figure 141 SMS_MessageWaitingIndicator parameter

6.5.2.130 SMS_NotificationIndicator

The) parameter is used to control the sending of subsequent SMSNotification messages.

Field	Value	Type	Reference	Notes					
Identifier	SMS_NotificationIndicator IMPLICIT OCTET STRING	M	6.5.1.2						
Length	variable octets	M	6.5.1.1						
Contents									
H	G	F	E	D	C	B	A	octet	Notes
SMS Notification Indicator								1	
...								<i>n</i>	<i>a</i>

Figure 142 SMS_NotificationIndicator parameter

Notes:

- a. Ignore extra octets, if received. Send only defined (or significant) octets.

Table 173 SMS_NotificationIndicator value

SMS Notification Indicator (octet 1)										
Bits	H	G	F	E	D	C	B	A	Value	Meaning
	0	0	0	0	0	0	0	0	0	Not used.
	0	0	0	0	0	0	0	1	1	Notify when available. If the indicated subscriber is not currently available, notify sender when MS becomes available.
	0	0	0	0	0	0	1	0	2	Do not notify when available. If the indicated subscriber is not currently available, do NOT notify sender when MS becomes available.
	0	0	0	0	0	0	1	1	3	} Reserved. Treat the same as value 1, <i>Notify when available.</i>
				...					through 127	
	0	1	1	1	1	1	1	1	127	} Reserved. Treat the same as value 2, <i>Do not notify when available.</i>
	1	0	0	0	0	0	0	0	128	
	1	1	0	1	1	1	1	1	223	} Reserved. Treat the same as value 2, <i>Do not notify when available.</i>
				...					through 223	
	1	1	1	0	0	0	0	0	224	} Reserved for TIA/EIA-41 protocol extension. If unknown, treat the same as value 1, <i>Notify when available.</i>
	1	1	1	1	1	1	1	1	255	

6.5.2.131 SMS_OriginalDestinationAddress

The SMS_OriginalDestinationAddress parameter is the address of the original message destination.

Field	Value	Type	Reference	Notes					
Identifier	SMS_OriginalDestinationAddress IMPLICIT DigitsType	M	6.5.1.2	a					
Length	variable octets	M	6.5.1.1						
Contents									
H	G	F	E	D	C	B	A	octet	Notes
Type of Digits								1	b
Nature of Number								2	c
Numbering Plan				Encoding				3	d, e
Number of Digits								4	f
2 nd BCD Digit				1 st BCD Digit				5	
4 th BCD Digit				3 rd BCD Digit				6	
...				
n^{th} BCD Digit				$n-1^{\text{st}}$ BCD Digit				m	

Figure 143 SMS_OriginalDestinationAddress parameter for BCD digits

Notes:

- a. See the DigitsType parameter type (see 6.5.3.2) for notes and field encoding.
- b. Type of Digits is ignored on receipt.
- c. The Nature of Number field may be *National* or *International*.
- d. Numbering Plan supported shall include *E.164*, *X.121*, and *Private numbering plan* for this parameter variant.
- e. The encoding field shall always be set to *BCD* for this parameter variant.
- f. The Number of Digits ranges from 0 to at least 15.

Field	Value	Type	Reference	Notes					
Identifier	SMS_OriginalDestinationAddress IMPLICIT DigitsType	M	6.5.1.2	a					
Length	variable octets	M	6.5.1.1						
Contents									
H	G	F	E	D	C	B	A	octet	Notes
Type of Digits								1	b
Nature of Number								2	c
Numbering Plan				Encoding				3	d, e
Number of Digits								4	f
1 st IA5 Character								5	
2 nd IA5 Character								6	
...								...	
Last IA5 Character								<i>m</i>	

Figure 144 SMS_OriginalDestinationAddress parameter for IA5 digits

Notes:

- a. See the DigitsType parameter type (see 6.5.3.2) for notes and field encoding.
- b. Type of Digits is ignored on receipt.
- c. The Nature of Number field may be *National* or *International*.
- d. Numbering Plan shall be *IP* for this parameter variant.
- e. The encoding field is set to *IA5* for this parameter variant.
- f. The Number of Digits ranges from 0 to 129.

Field	Value	Type	Reference	Notes					
Identifier	SMS_OriginalDestinationAddress IMPLICIT DigitsType	M	6.5.1.2	a					
Length	variable octets	M	6.5.1.1						
Contents									
H	G	F	E	D	C	B	A	octet	Notes
Type of Digits								1	b
Nature of Number								2	c
Numbering Plan				Encoding				3	d, e
MSB IP Address LSB								4	
								5	
								6	
								7	

Figure 145 SMS_OriginalDestinationAddress parameter for an IP address

Notes:

- a. See the DigitsType parameter type (see 6.5.3.2) for notes and field encoding.
- b. Type of Digits is ignored on receipt.
- c. The Nature of Number field may be *National* or *International*.
- d. Numbering Plan shall be *IP* for this parameter variant.
- e. Encoding shall be *octet string* for this parameter variant.

6.5.2.132 SMS_OriginalDestinationSubaddress

The SMS_OriginalDestinationSubaddress parameter is the subaddress of the original message destination.

Field	Value	Type	Reference	Notes					
Identifier	SMS_OriginalDestination-Subaddress IMPLICIT Subaddress	M	6.5.1.2	a					
Length	variable octets	M	6.5.1.1						
Contents									
H	G	F	E	D	C	B	A	octet	Notes
1	Type of Subaddress			O/E	Reserved			1	a
Subaddress ...								2	a
								3	
								...	
								<i>n</i>	

Figure 146 SMS_OriginalDestinationSubaddress parameter

Notes:

- a. Refer to the Subaddress parameter type (see 6.5.3.13) for notes and field encoding.

6.5.2.133 SMS_OriginalOriginatingAddress

The SMS_OriginalOriginatingAddress parameter is the address of the original message sender.

Field	Value	Type	Reference	Notes					
Identifier	SMS_OriginalOriginatingAddress IMPLICIT DigitsType	M	6.5.1.2	a					
Length	variable octets	M	6.5.1.1						
Contents									
H	G	F	E	D	C	B	A	octet	Notes
Type of Digits								1	b
Nature of Number								2	c
Numbering Plan				Encoding				3	d, e
Number of Digits								4	f
2 nd BCD Digit				1 st BCD Digit				5	
4 th BCD Digit				3 rd BCD Digit				6	
...				
n^{th} BCD Digit				$n-1^{\text{st}}$ BCD Digit				m	

Figure 147 SMS_OriginalOriginatingAddress parameter for BCD Digits

Notes:

- a. See the DigitsType parameter type (see 6.5.3.2) for notes and field encoding.
- b. Type of Digits field is ignored on receipt.
- c. The Nature of Number field may be *National* or *International*.
- d. Numbering Plan supported shall include *E.164*, *X.121*, and *Private numbering plan* for this parameter variant.
- e. The Encoding field shall always be set to *BCD* for this parameter variant.
- f. The Number of Digits ranges from 0 to at least 15.

Field	Value	Type	Reference	Notes					
Identifier	SMS_OriginalOriginatingAddress IMPLICIT DigitsType	M	6.5.1.2	a					
Length	variable octets	M	6.5.1.1						
Contents									
H	G	F	E	D	C	B	A	octet	Notes
Type of Digits								1	b
Nature of Number								2	c
Numbering Plan				Encoding				3	d, e
Number of Digits								4	f
1 st IA5 Character								5	
2 nd IA5 Character								6	
...								...	
Last IA5 Character								<i>m</i>	

Figure 148 SMS_OriginalOriginatingAddress parameter for IA5 digits

Notes:

- a. See the DigitsType parameter type (see 6.5.3.2) for notes and field encoding.
- b. Type of Digits is ignored on receipt.
- c. The Nature of Number field may be *National* or *International*.
- d. Numbering Plan shall be *IP* for this parameter variant.
- e. The encoding field is set to *IA5* for this parameter variant.
- f. The Number of Digits ranges from 0 to 129.

6.5.2.134 SMS_OriginalOriginatingSubaddress

The SMS_OriginalOriginatingSubaddress parameter is the subaddress of the original message sender.

Field	Value	Type	Reference	Notes					
Identifier	SMS_OriginalOriginating-Subaddress IMPLICIT Subaddress	M	6.5.1.2	a					
Length	variable octets	M	6.5.1.1						
Contents									
H	G	F	E	D	C	B	A	octet	Notes
1	Type of Subaddress			O/E	Reserved			1	a
Subaddress ...								2	a
								3	
								...	
								<i>n</i>	

Figure 150 SMS_OriginalOriginatingSubaddress parameter

Notes:

- a. Refer to the Subaddress parameter type (see 6.5.3.13) for the definition of these fields.

6.5.2.135 SMS_OriginatingAddress

The SMS_OriginatingAddress parameter is used to convey the current routing address of an MS based SME.

Field	Value	Type	Reference	Notes					
Identifier	SMS_OriginatingAddress IMPLICIT DigitsType	M	6.5.1.2	a					
Length	variable octets	M	6.5.1.1						
Contents									
H	G	F	E	D	C	B	A	octet	Notes
Type of Digits								1	b
Nature of Number								2	c
Numbering Plan				Encoding				3	d, e
Number of Digits								4	f
2 nd BCD Digit				1 st BCD Digit				5	
4 th BCD Digit				3 rd BCD Digit				6	
...				
n^{th} BCD Digit				$n-1^{\text{st}}$ BCD Digit				m	

Figure 151 SMS_OriginatingAddress parameter for BCD digits

Notes:

- a. See the DigitsType parameter type (see 6.5.3.2) for notes and field encoding.
- b. Type of Digits is ignored on receipt.
- c. Nature of Number may be *National* or *International*.
- d. Numbering Plan supported shall include *E.164*, *X.121*, and *Private numbering plan* for this parameter variant.
- e. The encoding field shall always be set to *BCD* for this parameter variant.
- f. The Number of Digits ranges from 0 to at least 15.

6.5.2.136 SMS_OriginationRestrictions

The SMS_OriginationRestrictions parameter defines the type of messages the MS is allowed to originate.

Field	Value	Type	Reference	Notes					
Identifier	SMS_OriginationRestrictions IMPLICIT OCTET STRING	M	6.5.1.2						
Length	variable octets	M	6.5.1.1						
Contents									
H	G	F	E	D	C	B	A	octet	Notes
Reserved				FMC	DIRECT	DEFAULT		1	a
				...			<i>n</i>	b	

Figure 153 SMS_OriginationRestrictions parameter

Notes:

- a. Reserved bits shall be ignored on receipt and set to zero on sending.
- b. Ignore extra octets, if received. Send only defined (or significant) octets.

Table 174 SMS_OriginationRestrictions value

<i>DEFAULT (octet 1, bits A and B)</i>										
Bits	H	G	F	E	D	C	B	A	Value	Meaning
							0	0	0	Block all. Block all message originations regardless of more specific settings.
							0	1	1	Reserved.
							1	0	2	Allow specific. Allow all message originations unless otherwise blocked or directed.
							1	1	3	Allow all. Allow all message originations regardless of more specific settings.
<i>DIRECT (octet 1, bit C)</i>										
Bits	H	G	F	E	D	C	B	A	Value	Meaning
						0			0	Block Direct. Block message originations requesting direct routing (i.e., bypassing the originating subscriber's Message Center).
						1			1	Allow Direct. Allow message originations requesting direct routing (i.e., bypassing the originating subscriber's Message Center).
<i>Force Message Center (FMC) (octet 1, bit D)</i>										
Bits	H	G	F	E	D	C	B	A	Value	Meaning
					0				0	No effect.
					1				1	Force Indirect. Force message originations to use indirect routing through the originating subscriber's Message Center.

6.5.2.137 SMS_TeleserviceIdentifier

The SMS_TeleserviceIdentifier parameter indicates the teleservice for which the SMS message applies.

Field	Value	Type	Reference	Notes					
Identifier	SMS_TeleserviceIdentifier IMPLICIT OCTET STRING	M	6.5.1.2						
Length	variable octets	M	6.5.1.1						
Contents									
H	G	F	E	D	C	B	A	octet	Notes
MSB SMS Teleservice Identifier								1	
LSB								2	
...								<i>n</i>	<i>a</i>

Figure 154 SMS_TeleserviceIdentifier parameter

Notes:

- a. Ignore extra octets, if received. Send only defined (or significant) octets.

Table 175 SMS_Teleservice Identifier values

<i>SMS Teleservice Identifier (octets 1 and 2)</i>	
0	Not used.
1	Reserved for maintenance.
2	} Reserved for assignment by <i>TIA/EIA-41</i> .
through	
4095	
4096	AMPS Extended Protocol Enhanced Service [AMPS].
4097	CDMA Cellular Paging Teleservice [CDMA].
4098	CDMA Cellular Messaging Teleservice [CDMA].
4099	CDMA [CDMA].
4100	} Reserved for assignment by <i>TIA/EIA-41</i> .
through	
32512	
32513	TDMA Cellular Messaging Teleservice [TDMA].
32514	} Reserved for assignment by this Standard for TDMA MS-based SMEs.
through	
32639	
32640	} Reserved for for TDMA MS-based SMEs. These teleservices may be assigned by carriers. No mechanism is defined for resolving conflicts between individual carriers. Originating supplementary services may be supported only with bilateral agreements.
through	
32767	
32768	
32768	} Reserved for . These teleservices may be assigned freely by any node operator. Use of these identifiers must be negotiated between the message originator and destination. Only supplementary services not requiring teleservice parameters may be supported.
through	
49151	
49152	} Reserved for . These teleservices may be assigned by carriers. No mechanism is defined for resolving conflicts between individual carriers. Originating supplementary services may be supported only with bilateral agreements.
through	
65535	

6.5.2.138 SMS_TerminationRestrictions

The SMS_TerminationRestrictions parameter defines the type of messages the MS is allowed to receive.

Field	Value	Type	Reference	Notes					
Identifier	SMS_TerminationRestrictions IMPLICIT OCTET STRING	M	6.5.1.2						
Length	variable octets	M	6.5.1.1						
Contents									
H	G	F	E	D	C	B	A	octet	Notes
Reserved					RC	DEFAULT		1	a
...									b

Figure 155 SMS_TerminationRestrictions parameter

Notes:

- a. Reserved bits shall be ignored on receipt and set to zero on sending.
- b. Ignore extra octets, if received. Send only defined (or significant) octets.

Table 176 SMS_TerminationRestrictions value

<i>DEFAULT (octet 1, bits A and B)</i>										
Bits	H	G	F	E	D	C	B	A	Value	Meaning
							0	0	0	Block all. Block all message terminations regardless of more specific settings.
							0	1	1	Reserved.
							1	0	2	Allow specific. Allow message terminations specifically allowed.
							1	1	3	Allow all. Allow message terminations regardless of more specific settings.
<i>Reverse Charges (RC) (octet 1, bit C)</i>										
Bits	H	G	F	E	D	C	B	A	Value	Meaning
						0			0	Block message terminations charged to the destination.
						1			1	Allow message terminations charged to the destination.

6.5.2.139 SPINIPIN

The SPINIPIN parameter contains the personal identification number (PIN) for the designated subscriber. The PIN may be required on origination of certain types of calls.

Field	Value	Type	Reference	Notes					
Identifier	SPINIPIN IMPLICIT DigitsType	M	6.5.1.2	a					
Length	variable octets	M	6.5.1.1						
Contents									
H	G	F	E	D	C	B	A	octet	Notes
Type of Digits								1	b
Nature of Number								2	c
Numbering Plan				Encoding				3	d, e
Number of Digits								4	f
2 nd Digit				1 st Digit				5	
4 th Digit				3 rd Digit				6	
...				
<i>n</i> th Digit				<i>n-1</i> st Digit				<i>m</i>	

Figure 156 SPINIPIN parameter

Notes:

- a. Refer to the DigitsType parameter type (see 6.5.3.2) for notes and field encoding.
- b. The Type of Digits field is ignored on receipt.
- c. The Nature of Number field is ignored on receipt.
- d. The Numbering Plan field is ignored on receipt.
- e. The Encoding field is set to *BCD*.
- f. The Number of Digits is between 0 and at least 15.

6.5.2.140 SPINITriggers

The SPINITriggers parameter defines the trigger points that are currently active for the subscriber.

Field	Value	Type	Reference	Notes					
Identifier	SPINITriggers IMPLICIT OCTET STRING	M	6.5.1.2						
Length	variable octets	M	6.5.1.1						
Contents									
H	G	F	E	D	C	B	A	octet	Notes
RvtC	Unrec	WZ	Inl'	OLATA	ILATA	Local	All	1	
Reserved			PA	DP	Pound	DS	Star	2	a
7 digits	6 digits	5 digits	4 digits	3 digits	2 digits	1 digit	No digits	3	
15 digits	14 digits	13 digits	12 digits	11 digits	10 digits	9 digits	8 digits	4	
...								n	b

Figure 157 SPINITriggers parameter

Notes:

- Set reserved values to 0 when sending, and process other triggers before treating received reserved values the same as *All*.
- If unknown octets with bits set are received, process other triggers before treating the same as *All*. Send only defined (or significant) octets.

Table 177 SPINITriggers value

<i>All Origination (All) (octet 1, bit A)</i>											
Bits	H	G	F	E	D	C	B	A	Value	Meaning	
									0	0	Trigger is not active.
									1	1	Execute local SPINI procedures for any call origination. This overrides all other values.
<i>Local (octet 1, bit B)</i>											
Bits	H	G	F	E	D	C	B	A	Value	Meaning	
									0	0	Trigger is not active.
									1	1	Execute local SPINI procedures for any local call attempt.
<i>Intra-LATA (ILATA) (octet 1, bit C)</i>											
Bits	H	G	F	E	D	C	B	A	Value	Meaning	
									0	0	Trigger is not active.
									1	1	Execute local SPINI procedures for any intra-LATA call attempt.

#

Table 177 (continued)

<i>Inter-LATA Toll (OLATA) (octet 1, bit D)</i>											#
Bits	H	G	F	E	D	C	B	A	Value	Meaning	#
					0				0	Trigger is not active.	#
					1				1	Execute local SPINI procedures for any inter-LATA toll call attempt.	#
<i>International (Int'l) (octet 1, bit E)</i>											#
Bits	H	G	F	E	D	C	B	A	Value	Meaning	#
				0					0	Trigger is not active.	#
				1					1	Execute local SPINI procedures for any international call attempt.	#
<i>World Zone (WZ) (octet 1, bit F)</i>											#
Bits	H	G	F	E	D	C	B	A	Value	Meaning	#
				0					0	Trigger is not active.	#
				1					1	Execute local SPINI procedures for any call attempt outside of the current World Zone (as defined in ITU-T Rec. E.164).	#
<i>Unrecognized Number (Unrec) (octet 1, bit G)</i>											#
Bits	H	G	F	E	D	C	B	A	Value	Meaning	#
			0						0	Trigger is not active.	#
			1						1	Execute local SPINI procedures for any call attempt to an unrecognized number.	#
<i>Revertive Vall (RvtC) (octet 1, bit H)</i>											#
Bits	H	G	F	E	D	C	B	A	Value	Meaning	#
			0						0	Trigger is not active.	#
			1						1	Execute local SPINI procedures for any Revertive Call attempt.	#
<i>Star (octet 2, bit A)</i>											#
Bits	H	G	F	E	D	C	B	A	Value	Meaning	#
								0	0	Trigger is not active.	#
								1	1	Execute local SPINI procedures for any number beginning with a Star '*' digit.	#
<i>Double Star (DS) (octet 2, bit B)</i>											#
Bits	H	G	F	E	D	C	B	A	Value	Meaning	#
							0		0	Trigger is not active.	#
							1		1	Execute local SPINI procedures for any number beginning with two Star '**' digits.	#
<i>Pound (octet 2, bit C)</i>											#
Bits	H	G	F	E	D	C	B	A	Value	Meaning	#
						0			0	Trigger is not active.	#
						1			1	Execute local SPINI procedures for any number beginning with a Pound '#' digit.	#

Table 177 (continued)

<i>Double Pound (DP) (octet 2, bit D)</i>										
Bits	H	G	F	E	D	C	B	A	Value	Meaning
					0				0	Trigger is not active.
					1				1	Execute local SPINI procedures for any number beginning with two Pound #'s digits.
<i>Prior Agreement (PA) (octet 2, bit E)</i>										
Bits	H	G	F	E	D	C	B	A	Value	Meaning
				0					0	Trigger is not active.
				1					1	Execute local SPINI procedures for any number matching a criteria of a prior agreement.
<i>No digits (octet 3, bit A)</i>										
Bits	H	G	F	E	D	C	B	A	Value	Meaning
									0	Trigger is not active.
									1	Execute local SPINI procedures for any call attempt with no digits.
<i>1 digit (octet 3, bit B)</i>										
Bits	H	G	F	E	D	C	B	A	Value	Meaning
									0	Trigger is not active.
									1	Execute local SPINI procedures for any call attempt with 1 digit.
<i>2 digits (octet 3, bit C)</i>										
Bits	H	G	F	E	D	C	B	A	Value	Meaning
									0	Trigger is not active.
									1	Execute local SPINI procedures for any call attempt with 2 digits.
<i>3 digits (octet 3, bit D)</i>										
Bits	H	G	F	E	D	C	B	A	Value	Meaning
									0	Trigger is not active.
									1	Execute local SPINI procedures for any call attempt with 3 digits.
<i>4 digits (octet 3, bit E)</i>										
Bits	H	G	F	E	D	C	B	A	Value	Meaning
									0	Trigger is not active.
									1	Execute local SPINI procedures for any call attempt with 4 digits.
<i>5 digits (octet 3, bit F)</i>										
Bits	H	G	F	E	D	C	B	A	Value	Meaning
									0	Trigger is not active.
									1	Execute local SPINI procedures for any call attempt with 5 digits.

Table 177 (continued)

<i>6 digits (octet 3, bit G)</i>										
Bits	H	G	F	E	D	C	B	A	Value	Meaning
		0							0	Trigger is not active.
		1							1	Execute local SPINI procedures for any call attempt with 6 digits.
<i>7 digits (octet 3, bit H)</i>										
Bits	H	G	F	E	D	C	B	A	Value	Meaning
		0							0	Trigger is not active.
		1							1	Execute local SPINI procedures for any call attempt with 7 digits.
<i>8 digits (octet 4, bit A)</i>										
Bits	H	G	F	E	D	C	B	A	Value	Meaning
								0	0	Trigger is not active.
								1	1	Execute local SPINI procedures for any call attempt with 8 digits.
<i>9 digits (octet 4, bit B)</i>										
Bits	H	G	F	E	D	C	B	A	Value	Meaning
								0	0	Trigger is not active.
								1	1	Execute local SPINI procedures for any call attempt with 9 digits.
<i>10 digits (octet 4, bit C)</i>										
Bits	H	G	F	E	D	C	B	A	Value	Meaning
						0			0	Trigger is not active.
						1			1	Execute local SPINI procedures for any call attempt with 10 digits.
<i>11 digits (octet 4, bit D)</i>										
Bits	H	G	F	E	D	C	B	A	Value	Meaning
					0				0	Trigger is not active.
					1				1	Execute local SPINI procedures for any call attempt with 11 digits.
<i>12 digits (octet 4, bit E)</i>										
Bits	H	G	F	E	D	C	B	A	Value	Meaning
				0					0	Trigger is not active.
				1					1	Execute local SPINI procedures for any call attempt with 12 digits.
<i>13 digits (octet 4, bit F)</i>										
Bits	H	G	F	E	D	C	B	A	Value	Meaning
			0						0	Trigger is not active.
			1						1	Execute local SPINI procedures for any call attempt with 13 digits.

1
2
3
4
5
6
7
8
9
10
11
12
13
14
15
16
17
18
19
20
21
22
23
24
25
26
27
28
29
30
31
32
33
34
35
36
37
38
39
40
41
42
43
44
45
46
47
48
49
50
51
52
53
54
55
56
57
58
59
60

Table 177 (concluded)

<i>14 digits (octet 4, bit G)</i>										
Bits	H	G	F	E	D	C	B	A	Value	Meaning
		0							0	Trigger is not active.
		1							1	Execute local SPINI procedures for any call attempt with 14 digits.
<i>15 digits (octet 4, bit H)</i>										
Bits	H	G	F	E	D	C	B	A	Value	Meaning
		0							0	Trigger is not active.
		1							1	Execute local SPINI procedures for any call attempt with 15 or more digits.

6.5.2.141 SSDNotShared

The SSDNotShared (NOSSD) parameter is used by the home system to indicate that the previously provided SSD is no longer valid.

Field	Value	Type	Reference	Notes					
Identifier	SSDNotShared IMPLICIT Unsigned Enumerated	M	6.5.1.2						
Length	1 octet	M	6.5.1.1						
Contents									
H	G	F	E	D	C	B	A	octet	Notes
SSD Not Shared								1	a

Figure 158 SSDNotShared parameter

Table 178 SSDNotShared value

<i>SSD Not Shared (octet 1)</i>										
Bits	H	G	F	E	D	C	B	A	Value	Meaning
	0	0	0	0	0	0	0	0	0	Not used.
	0	0	0	0	0	0	0	1	1	Discard SSD.
	0	0	0	0	0	0	1	0	2	} Reserved. Treat the same as value 1, <i>Discard SSD.</i>
				...					through	
	1	1	1	1	1	1	1	1	255	

6.5.2.142 SSDUpdateReport

The SSDUpdateReport (SSDURPT) parameter indicates the outcome of the SSD Update initiated by the AC.

Field	Value	Type	Reference	Notes					
Identifier	SSDUpdateReport IMPLICIT OCTET STRING	M	6.5.1.2						
Length	variable octets	M	6.5.1.1						
Contents									
H	G	F	E	D	C	B	A	octet	Notes
SSD Update Report								1	
...								<i>n</i>	<i>a</i>

Figure 159 SSDUpdateReport parameter

Notes:

- a. Ignore extra octets, if received. Send only defined (or significant) octets.

Table 179 SSDUpdateReport value

<i>SSD Update Report (octet 1)</i>										
Bits	H	G	F	E	D	C	B	A	Value	Meaning
	0	0	0	0	0	0	0	0	0	Not used.
	0	0	0	0	0	0	0	1	1	SSD Update not attempted.
	0	0	0	0	0	0	1	0	2	SSD Update no response.
	0	0	0	0	0	0	1	1	3	SSD Update successful.
	0	0	0	0	0	1	0	0	4	SSD Update failed.
	0	0	0	0	0	1	0	1	5	} Reserved. Treat the same as value 1, <i>SSD Update not attempted.</i>
				...					through 223	
	1	1	0	1	1	1	1	1	224	} Reserved for <i>TIA/EIA-41</i> protocol extension. If unknown, treat the same as value 1, <i>SSD Update not attempted.</i>
	1	1	1	0	0	0	0	0	through 255	
	1	1	1	1	1	1	1	1	255	

6.5.2.143 StationClassMark

The StationClassMark (SCM) parameter is used to indicate the power class and station type of the subscriber unit. This is used in accordance with the *AMPS* and *TDMA* air interface standards.

Field	Value	Type	Reference	Notes					
Identifier	StationClassMark IMPLICIT OCTET STRING	M	6.5.1.2						
Length	1 octet	M	6.5.1.1						
Contents									
H	G	F	E	D	C	B	A	octet	Notes
Reserved			PC	BW	TX	PC	PC	1	a

Figure 160 StationClassMark parameter

Notes:

- a. Reserved bits shall be ignored on receipt and set to zero on sending.

Table 180 StationClassMark value

<i>Power Class (PC) (octet 1, bits A, B, and E)</i>										
Bits	H	G	F	E	D	C	B	A	Value	Meaning
				0			0	0	-	Class I.
				0			0	1	-	Class II.
				0			1	0	-	Class III.
				0			1	1	-	Class IV.
				1			0	0	-	Class V.
				1			0	1	-	Class VI.
				1			1	0	-	Class VII.
				1			1	1	-	Class VIII.
<i>Transmission (TX) (octet 1, bit C)</i>										
Bits	H	G	F	E	D	C	B	A	Value	Meaning
						0			-	Continuous.
						1			-	Discontinuous.
<i>Bandwidth (BW) (octet 1, bit D)</i>										
Bits	H	G	F	E	D	C	B	A	Value	Meaning
					0				-	20 MHz.
					1				-	25 MHz.

6.5.2.144 SystemAccessData

The SystemAccessData (SYSACCDATA) parameter is used to indicate the Serving MSC and cell site to the HLR or VLR so that the multiple access detection algorithm can identify the specific MSCs and cell sites which were simultaneously accessed by the MS. The "serving" system is considered to be the system which is known to have reported the best SignalQuality at the time that this parameter is encoded.

Field	Value	Type	Reference	Notes					
Identifier	SystemAccessData IMPLICIT OCTET STRING	M	6.5.1.2						
Length	5 octets	M	6.5.1.1						
Contents									
H	G	F	E	D	C	B	A	octet	Notes
MSB Serving MarketID								1	a
LSB								2	
Serving Switch Number								3	a
MSB Serving Cell ID								4	
LSB								5	

Figure 161 SystemAccessData parameter

Notes:

- a. Refer to the MSCID parameter (see 6.5.2.82) for the definition of these fields.

6.5.2.145 SystemAccessType

The SystemAccessType (SYSACCTYPE) parameter defines the type of system access made by the MS.

Field	Value	Type	Reference	Notes					
Identifier	SystemAccessType IMPLICIT Unsigned Enumerated	M	6.5.1.2						
Length	1 octet	M	6.5.1.1						
Contents									
H	G	F	E	D	C	B	A	octet	Notes
SystemAccessType								1	

Figure 162 SystemAccessType parameter

Table 181 SystemAccessType value

<i>SystemAccessType (octet 1)</i>										
Bits	H	G	F	E	D	C	B	A	Value	Meaning
	0	0	0	0	0	0	0	0	0	Not used.
	0	0	0	0	0	0	0	1	1	Unspecified.
	0	0	0	0	0	0	1	0	2	Flash request.
	0	0	0	0	0	0	1	1	3	Autonomous registration.
	0	0	0	0	0	1	0	0	4	Call origination.
	0	0	0	0	0	1	0	1	5	Page response.
	0	0	0	0	0	1	1	0	6	No access. Used when the authentication procedure was initiated on the Control Channel.
	0	0	0	0	0	1	1	1	7	Power down registration.
	0	0	0	0	1	0	0	0	8	SMS page response.
	0	0	0	0	1	0	0	1	9	} Reserved. Treat the same as value 1, <i>Unspecified.</i>
				...					through	
	1	1	0	1	1	1	1	1	223	
	1	1	1	0	0	0	0	0	224	} Reserved for TIA/EIA-41 protocol extension. If unknown, treat the same as value 1, <i>Unspecified.</i>
				...					through	
	1	1	1	1	1	1	1	1	255	

6.5.2.146 SystemCapabilities

The SystemCapabilities (SYSCAP) parameter defines the capabilities of the serving system, especially regarding authentication. For example, when allowed by local AC administrative policies, it provides an AC with the option to send a subscriber's SSD to a VLR capable of executing CAVE, thereby off-loading the AC and reducing the number of intersystem transactions. It also allows the response from the AC to be customized to the capabilities of the serving system, eliminating the transmission of unnecessary, and often lengthy, data.

Field	Value	Type	Reference	Notes					
Identifier	SystemCapabilities IMPLICIT OCTET STRING	M	6.5.1.2						
Length	1 octet	M	6.5.1.1						
Contents									
H	G	F	E	D	C	B	A	octet	Notes
Reserved			SSD	CAVE	VP	SE	AUTH	1	a

Figure 163 SystemCapabilities parameter

Notes:

- a. Reserved bits shall be ignored on receipt and set to zero on sending.

Table 182 SystemCapabilities value

<i>Authentication Parameters Requested (AUTH) (octet 1, bit A)</i>											
Bits	H	G	F	E	D	C	B	A	Value	Meaning	
									0	0	Authentication parameters were not requested on this system access (AUTH=0 in the OMT).
									1	1	Authentication parameters were requested on this system access (AUTH=1 in the OMT).
<i>Signaling Message Encryption Capable (SE) (octet 1, bit B)</i>											
Bits	H	G	F	E	D	C	B	A	Value	Meaning	
									0	0	Signaling Message Encryption not supported by the system.
									1	1	Signaling Message Encryption is supported by the system.
<i>Voice Privacy Capable (VP) (octet 1, bit C)</i>											
Bits	H	G	F	E	D	C	B	A	Value	Meaning	
									0	0	Voice Privacy not supported by the system.
									1	1	Voice Privacy is supported by the system.
<i>CAVE Algorithm Capable (CAVE) (octet 1, bit D)</i>											
Bits	H	G	F	E	D	C	B	A	Value	Meaning	
									0	0	System cannot execute the CAVE algorithm and cannot share SSD for the indicated MS.
									1	1	System can execute the CAVE algorithm and share SSD for the indicated MS.
<i>Shared SSD (SSD) (octet 1, bit E)</i>											
Bits	H	G	F	E	D	C	B	A	Value	Meaning	
									0	0	SSD is not shared with the system for the indicated MS.
									1	1	SSD is shared with the system for the indicated MS.

6.5.2.147 SystemMyTypeCode

The SystemMyTypeCode (MYTYP) parameter indicates the vendor of a system.

Field	Value	Type	Reference	Notes					
Identifier	SystemMyTypeCode IMPLICIT Unsigned Enumerated	M	6.5.1.2						
Length	1 octet	M	6.5.1.1						
Contents									
H	G	F	E	D	C	B	A	octet	Notes
Vendor Identifier								1	a, b

Figure 164 SystemMyTypeCode parameter

Notes:

- a. SystemMyTypeCode identifiers may be obtained from the chairman of the TIA TR-45.2 Subcommittee through the TIA.
- b. The SystemMyTypeCode should be ignored unless the value is for the vendor's own system.

Table 183 SystemMyTypeCode value

<i>Vendor Identifier (octet 1)</i>											
Bits	H	G	F	E	D	C	B	A	Value	Meaning	
	0	0	0	0	0	0	0	0	0	0	Not used.
	0	0	0	0	0	0	0	0	1	1	EDS.
	0	0	0	0	0	0	0	1	0	2	Astronet.
	0	0	0	0	0	0	0	1	1	3	Lucent Technologies.
	0	0	0	0	0	1	0	0	0	4	Ericsson.
	0	0	0	0	0	1	0	1	5	GTE.	
	0	0	0	0	0	1	1	0	6	Motorola.	
	0	0	0	0	0	1	1	1	7	NEC.	
	0	0	0	0	1	0	0	0	8	NORTEL.	
	0	0	0	0	1	0	0	1	9	NovAtel.	
	0	0	0	0	1	0	1	0	10	Plexsys.	
	0	0	0	0	1	0	1	1	11	Digital Equipment Corp.	
	0	0	0	0	1	1	0	0	12	INET.	
	0	0	0	0	1	1	0	1	13	Bellcore.	
	0	0	0	0	1	1	1	0	14	Alcatel SEL.	
	0	0	0	0	1	1	1	1	15	Tandem.	
	0	0	0	1	0	0	0	0	16	QUALCOMM.	
	0	0	0	1	0	0	0	1	17	Aldiscon.	
	0	0	0	1	0	0	1	0	18	Celcore.	
	0	0	0	1	0	0	1	1	19	TELOS.	
	0	0	0	1	0	1	0	0	20	Stanilite.	
	0	0	0	1	0	1	0	1	21	Coral Systems.	
	0	0	0	1	0	1	1	0	22	Synacom Technology.	
	0	0	0	1	0	1	1	1	23	DSC.	
	0	0	0	1	1	0	0	0	24	MCI.	
	0	0	0	1	1	0	0	1	25	NewNet.	
	0	0	0	1	1	0	1	0	26	Sema Group Telecoms.	
	0	0	0	1	1	0	1	1	27	LG Information and Communications.	
	0	0	0	1	1	1	0	0	28	CBIS.	
	0	0	0	1	1	1	0	1	29	Siemens.	
	0	0	0	1	1	1	1	0	30	} Reserved.	
				...					through		
	1	1	1	1	1	1	1	1	255		

6.5.2.148 TargetCellID

The TargetCellID (TCELLID) parameter specifies the ID of the target cell site to be used in this transaction.

Field	Value	Type	Reference	Notes					
Identifier	TargetCellID IMPLICIT OCTET STRING	M	6.5.1.2						
Length	2 octets	M	6.5.1.1						
Contents									
H	G	F	E	D	C	B	A	octet	Notes
MSB TargetCellID								1	
LSB								2	

Figure 165 TargetCellID parameter

6.5.2.149 TargetMeasurementInformation

The TargetMeasurementInformation (TMEAS) parameter specifies target cell information which is used in the handoff process.

Field	Value	Type	Reference	Notes
Identifier	TargetMeasurementInformation IMPLICIT SEQUENCE	M	6.5.1.2	
Length	variable	M	6.5.1.1	
Contents				
	TargetCellID	M	6.5.2.148	
	SignalQuality	M	6.5.2.121	
	...			a

Figure 166 TargetMeasurementInformation parameter

Notes:

- a. Ignore unexpected parameters, if received.

6.5.2.150 TargetMeasurementList

The TargetMeasurementList (TMEASLIST) parameter specifies target cell information which is used in the handoff process.

Field	Value	Type	Reference	Notes
Identifier	TargetMeasurementList IMPLICIT SEQUENCE OF	M	6.5.1.2	
Length	variable	M	6.5.1.1	
Contents				
	TargetMeasurementInformation	M	6.5.2.149	
	TargetMeasurementInformation	O	6.5.2.149	a
	...			

Figure 167 TargetMeasurementList parameter

Notes:

- a. Optionally include additional TargetMeasurementInformation parameters.

6.5.2.151 TDMABurstIndicator

This parameter was named ShortenedBurstIndicator prior to this revision of the Interim Standard.

The TDMABurstIndicator (TDMASBI) parameter indicates whether or not the MS is required to transmit shortened burst, after handoff, on the new digital traffic channel.

Field	Value	Type	Reference	Notes					
Identifier	TDMABurstIndicator IMPLICIT OCTET STRING	M	6.5.1.2						
Length	1 octet	M	6.5.1.1						
Contents									
H	G	F	E	D	C	B	A	octet	Notes
Res'd	Time Alignment Offset (TA)					Burst Code		1	a, b

Figure 168 TDMABurstIndicator parameter

Notes:

- Reserved (Res'd) bits shall be ignored on receipt and set to zero on sending.
- See *TDMA* for encoding of the Time Alignment Offset field.

Table 184 TDMABurstIndicator value

<i>Burst Code (octet 1, bits A and B)</i>										
Bits	H	G	F	E	D	C	B	A	Value	Meaning
							0	0	-	Transmit normal burst after cell-to-cell handoff.
							0	1	-	Transmit normal burst after handoff within cell.
							1	0	-	Transmit shortened burst after cell-to-cell handoff.
							1	1	-	Reserved. Treat with a RETURN ERROR.

6.5.2.152 TDMACallMode

This parameter was named CallMode prior to this revision of the Interim Standard.

The TDMACallMode (TDMAMODE) parameter is used to indicate the preferred mode in accordance with TDMA.

Field	Value	Type	Reference	Notes					
Identifier	TDMACallMode IMPLICIT OCTET STRING	M	6.5.1.2						
Length	1 octet	M	6.5.1.1						
Contents									
H	G	F	E	D	C	B	A	octet	Notes
Reserved		Call Mode						1	a

Figure 169 TDMACallMode parameter

Notes:

- a. Reserved bits shall be ignored on receipt and set to zero on sending.

Table 185 TDMACallMode value

Call Mode (octet 1, bits A-F)										
Bits	H	G	F	E	D	C	B	A	Value	Meaning
			0					0	-	AMPS channel acceptable.
			0					1	-	AMPS channel not acceptable.
			0				0		-	Full rate digital traffic channel not acceptable.
			0					1	-	Full rate digital traffic channel acceptable.
			0		0				-	Half rate digital traffic channel not acceptable.
			0			1			-	Half rate digital traffic channel acceptable.
			0	0					-	Other DQPSK channel not acceptable.
			0		1				-	Other DQPSK channel acceptable.
			0	0					-	Other voice coding not acceptable.
			0	1					-	Other voice coding acceptable.
			1						-	Extended modulation and framing.

6.5.2.153 TDMACHannelData

This parameter was named DigitalChannelData prior to this revision of the Interim Standard.

The TDMACHannelData (TDMADATA) parameter is used to indicate the Rate, the Digital Verification Color Code (DVCC), the Digital Mobile Attenuation Code (DMAC), and the of a TDMA digital channel. Rate, DVCC, DMAC, and Channel Number are in accordance with *TDMA*.

If an optional TDMACHannelData parameter is received in a transaction with a mandatory ChannelData parameter and the ChannelData parameter length is greater than zero, respond with a RETURN ERROR indicating *ParameterError*.

Field	Value	Type	Reference	Notes					
Identifier	TDMACHannelData IMPLICIT OCTET STRING	M	6.5.1.2						
Length	5 octets	M	6.5.1.1						
Contents									
H	G	F	E	D	C	B	A	octet	Notes
Reserved			TSR					1	a
								2	b
Reserved								3	a, b, c
MSB								4	b
							LSB	5	

Figure 170 TDMACHannelData parameter

Notes:

- a. Reserved bits shall be ignored on receipt and set to zero on sending.
- b. See *TDMA* for encoding of these fields.
- c. DMAC indicates the current power level of the MS associated with the digital channel being reported.

Table 186 TDMAChannelData value

<i>Time Slot and Rate indicator (TSR) (octet 1)</i>										
Bits	H	G	F	E	D	C	B	A	Value	Meaning
			0	0	0	0	0		0	Analog (not used if ChannelData is present).
			0	0	0	0	1		1	Assigned to timeslot 1, full rate.
			0	0	0	1	0		2	Assigned to timeslot 2, full rate.
			0	0	0	1	1		3	Assigned to timeslot 3, full rate.
			0	1	0	0	1		9	Assigned to timeslot 1, half rate.
			0	1	0	1	0		10	Assigned to timeslot 2, half rate.
			0	1	0	1	1		11	Assigned to timeslot 3, half rate.
			0	1	1	0	0		12	Assigned to timeslot 4, half rate.
			0	1	1	0	1		13	Assigned to timeslot 5, half rate.
			0	1	1	1	0		14	Assigned to timeslot 6, half rate.
	X	X	X	X	X	X	X		-	Other values are reserved. Treat a reserved value the same as value 0, <i>Analog</i> .

6.5.2.154 TerminalType

The TerminalType (TERMTYP) parameter identifies the radio frequency interface standard supported by the associated MS. The values of this parameter are derived from the Mobile Protocol Capability Indicator (see *AMPS*, *TDMA*, *NAMPS*, or *CDMA* MPCI) over the analog control channel, the CDMA control channel Mobile Protocol Revision Level (see *CDMA* MOB_P_REV), or other means.

Field	Value	Type	Reference	Notes					
Identifier	TerminalType IMPLICIT Unsigned Enumerated	M	6.5.1.2						
Length	1 octet	M	6.5.1.1						
Contents									
H	G	F	E	D	C	B	A	octet	Notes
TerminalType								1	

Figure 171 TerminalType parameter

Table 187 TerminalType value

<i>TerminalType (octet 1)</i>										
Bits	H	G	F	E	D	C	B	A	Value	Meaning
	0	0	0	0	0	0	0	0	0	Not used.
	0	0	0	0	0	0	0	1	1	Not distinguished (e.g., <i>EIA/TIA-553</i> , <i>IS-54-A</i> , <i>IS-88</i> , <i>IS-91</i> , <i>IS-94</i>).
	0	0	0	0	0	0	1	0	2	IS-54-B .
	0	0	0	0	0	0	1	1	3	IS-136 .
	0	0	0	0	0	1	0	0	4	} Reserved. Treat a reserved value the same as value 2, <i>IS-54-B</i> .
			...						through	
	0	0	0	1	1	1	1	1	31	
	0	0	1	0	0	0	0	0	32	IS-95 .
	0	0	1	0	0	0	0	1	33	IS-95-A .
	0	0	1	0	0	0	1	0	34	} Reserved. Treat a reserved value the same as value 33, <i>IS-95-A</i> .
			...						through	
	0	0	1	1	1	1	1	1	63	
	0	1	0	0	0	0	0	0	64	IS-88 .
	0	1	0	0	0	0	0	1	65	IS-94 .
	0	1	0	0	0	0	1	0	66	IS-91 .
	0	1	0	0	0	0	1	1	67	} Reserved. Treat the same the same as value 1, <i>Not distinguished</i> .
			...						through	
	1	1	0	1	1	1	1	1	223	
	1	1	1	0	0	0	0	0	224	} Reserved for <i>TIA/EIA-41</i> protocol extension. If unknown, treat a reserved value the same as value 1, <i>Not distinguished</i> .
			...						through	
	1	1	1	1	1	1	1	1	255	

6.5.2.155 TerminationAccessType

The TerminationAccessType (TAT) parameter identifies special access situations.

Field	Value	Type	Reference	Notes					
Identifier	TerminationAccessType IMPLICIT OCTET STRING	M	6.5.1.2						
Length	variable octets	M	6.5.1.1						
Contents									
H	G	F	E	D	C	B	A	octet	Notes
Termination Access Type								1	
...								<i>n</i>	<i>a</i>

Figure 172 TerminationAccessType parameter

Notes:

- a. Ignore extra octets, if received. Send only defined (or significant) octets.

Table 188 TerminationAccessType value

<i>Termination Access Type (octet 1)</i>										
Bits	H	G	F	E	D	C	B	A	Value	Meaning
	0	0	0	0	0	0	0	0	0	Not used.
	0	0	0	0	0	0	0	1	1	} Reserved for controlling system assignment (may be a trunk group identifier).
			...						through	
	0	1	1	1	1	1	1	1	127	
	1	0	0	0	0	0	0	0	128	} Reserved for TIA/EIA-41 protocol extension. If unknown, treat the same as value 253, Land-to-Mobile Directory Number access.
			...						through	
	1	0	1	0	0	0	0	0	160	
	1	0	1	0	0	0	0	1	161	} Reserved for this Standard.
			...						through	
	1	1	1	1	1	0	1	1	251	
	1	1	1	1	1	1	0	0	252	Mobile-to-Mobile Directory Number Access.
	1	1	1	1	1	1	0	1	253	Land-to-Mobile Directory Number Access.
	1	1	1	1	1	1	1	0	254	Remote Feature Control port access.
	1	1	1	1	1	1	1	1	255	Roamer port access.

6.5.2.156 TerminationList

The TerminationList (TERMLIST) parameter is used to provide an MSC with routing information, in the form of one or more terminations. A sequence of terminations would be provided for calls which involve multiple legs (e.g., a Flexible Alerting call).

Field	Value	Type	Reference	Notes
Identifier	TerminationList IMPLICIT SET OF CHOICE	M	6.5.1.2	a
Length	variable	M	6.5.1.1	
Contents				
	IntersystemTermination	O	6.5.2.74	b, c, d
	LocalTermination	O	6.5.2.76	b, c, e
	PSTNTermination	O	6.5.2.98	b, c, f
	...			g

Figure 173 TerminationList parameter

Notes:

- a. The number of terminations is limited by the sending system, the receiving system and the intervening network. This Standard does not specify a maximum number to allow the maximum to grow as technology advances.
- b. At least one parameter must be included within the TerminationList parameter.
- c. Optionally include additional CHOICE (IntersystemTermination, LocalTermination, PSTNTermination) parameters. There is no significance to the order of the parameters within the TerminationList parameter.
- d. Include if call leg is to an intersystem MSC.
- e. Include if call leg is to the local MSC.
- f. Include if call leg is to the PSTN.
- g. Ignore unexpected parameters, if received.

6.5.2.157 TerminationRestrictionCode

The TerminationRestrictionCode (TERMRES) parameter indicates the type of calls the MS is allowed to terminate.

This parameter may be ignored on receipt for *IS-41-C* and later. LocationRequest INVOKEs are required on all terminations.

Field	Value	Type	Reference	Notes					
Identifier	TerminationRestrictionCode IMPLICIT Unsigned Enumerated	M	6.5.1.2						
Length	1 octet	M	6.5.1.1						
Contents									
H	G	F	E	D	C	B	A	octet	Notes
TerminationRestrictionCode								1	

Figure 174 TerminationRestrictionCode parameter

Table 189 TerminationRestrictionCode parameter

<i>TerminationRestrictionCode (octet 1)</i>										
Bits	H	G	F	E	D	C	B	A	Value	Meaning
	0	0	0	0	0	0	0	0	0	Not used.
	0	0	0	0	0	0	0	1	1	Termination denied.
	0	0	0	0	0	0	1	0	2	Unrestricted.
	0	0	0	0	0	0	1	1	3	The treatment for this value is not specified.
	0	0	0	0	0	1	0	0	4	} Reserved. Treat a reserved value the same as value 2, <i>Unrestricted</i> .
			...						through 223	
	1	1	0	1	1	1	1	1	223	
	1	1	1	0	0	0	0	0	224	} Reserved for <i>TIA/EIA-41</i> protocol extension. If unknown, treat a reserved value the same as value 2, <i>Unrestricted</i> .
			...						through 255	
	1	1	1	1	1	1	1	1	255	

6.5.2.158 TerminationTreatment

The TerminationTreatment (TERMTRMT) parameter identifies the nature of call termination treatment (e.g., distinguishing call termination to an MS from call termination to a voice mailbox).

Field	Value	Type	Reference	Notes					
Identifier	TerminationTreatment IMPLICIT OCTET STRING	M	6.5.1.2						
Length	variable octets	M	6.5.1.1						
Contents									
H	G	F	E	D	C	B	A	octet	Notes
TerminationTreatment								1	
...								<i>n</i>	<i>a</i>

Figure 175 TerminationTreatment parameter

Notes:

- a. Ignore extra octets, if received. Send only defined (or significant) octets.

Table 190 TerminationTreatment parameter

<i>TerminationTreatment (octet 1)</i>										
Bits	H	G	F	E	D	C	B	A	Value	Meaning
	0	0	0	0	0	0	0	0	0	Not used.
	0	0	0	0	0	0	0	1	1	MS Termination. Termination to an MS.
	0	0	0	0	0	0	1	0	2	Voice Mail Storage. Termination to a voice mail box for message storage.
	0	0	0	0	0	0	1	1	3	Voice Mail Retrieval. Termination to a voice mail box for message retrieval.
	0	0	0	0	0	1	0	0	4	Dialogue Termination. Termination to a dialogue.
	0	0	0	0	0	1	0	1	5	} Reserved. Treat the same as an <i>Unrecognized parameter value</i> .
				...					through 223	
	1	1	0	1	1	1	1	1	224	} Reserved for <i>TIA/EIA-41</i> protocol extension. If unknown, treat the same as an <i>Unrecognized parameter value</i> .
	1	1	1	0	0	0	0	0	through 224	
	1	1	1	1	1	1	1	1	255	

6.5.2.159 TerminationTriggers

The TerminationTriggers (TERMTRIG) parameter defines the termination trigger points that are currently active for the subscriber.

Field	Value	Type	Reference	Notes					
Identifier	TerminationTriggers IMPLICIT OCTET STRING	M	6.5.1.2						
Length	variable octets	M	6.5.1.1						
Contents									
H	G	F	E	D	C	B	A	octet	Notes
NA		NPR		RF		Busy		1	a
Reserved							NR	2	a
...								<i>n</i>	b

Figure 176 TerminationTriggers parameter

Notes:

- Reserved bits shall be ignored on receipt and set to zero on sending.
- Ignore extra octets, if received. Send only defined (or significant) octets.

Table 191 TerminationTriggers value

<i>Busy (octet 1, bits A and B)</i>										
Bits	H	G	F	E	D	C	B	A	Value	Meaning
							0	0	0	Busy Call. Apply treatment for a detected busy condition local to the controlling system for the entire call.
							0	1	1	Busy Trigger. Launch a RedirectionRequest or TransferToNumberRequest for any detected busy condition.
							1	0	2	Busy Leg. For a multileg call apply treatment for a detected busy condition local to the controlling system for the affected leg only (e.g., drop this leg). For a single leg call with a detected busy condition, treat the same as value 0, <i>Busy Call</i> .
							1	1	3	Reserved. Treat as an unrecognized parameter value.

Table 191 (continued)

<i>Routing Failure (RF) (octet 1, bits C and D)</i>										
Bits	H	G	F	E	D	C	B	A	Value	Meaning
					0	0			0	Failed Call. Apply treatment for a detected routing failure (e.g., reach reorder, an SIT, unable to seize a trunk, facility shortage) local to the controlling system for the entire call.
					0	1			1	Routing Failure Trigger. Launch a RedirectionRequest or Transfer-ToNumberRequest for any detected routing failure.
					1	0			2	Failed Leg. For a multileg call apply treatment for a detected routing failure local to the controlling system for the affected leg only (e.g., drop this leg). For a single leg call with a detected routing failure, treat the same as value 0, <i>Failed Call</i> .
					1	1			3	Reserved. Treat as an unrecognized parameter value.
<i>No Page Response (NPR) (octet 1, bits E and F)</i>										
Bits	H	G	F	E	D	C	B	A	Value	Meaning
			0	0					0	No Page Response Call. Apply treatment for a detected no page response condition local to the controlling system for the entire call.
			0	1					1	No Page Response Trigger: Launch a RedirectionRequest or Transfer-ToNumberRequest for a detected no page response condition.
			1	0					2	No Page Response Leg. For a multileg call apply treatment for a detected no page response condition for the affected leg only (e.g., drop this leg). For a single leg call with a detected no page response condition, treat the same as value 0, <i>No Page Response Call</i> .
			1	1					3	Reserved. Treat as an unrecognized parameter value.

Table 191 (concluded)

<i>No Answer (NA) (octet 1, bits G and H)</i>										
Bits	H	G	F	E	D	C	B	A	Value	Meaning
	0	0							0	No Answer Call. Apply treatment for a detected “no answer” condition local to the controlling system for the entire call.
	0	1							1	No Answer Trigger. Launch a RedirectionRequest or Transfer-ToNumberRequest for any detected “no answer” condition.
	1	0							2	No Answer Leg. For a multileg call apply treatment for a detected “no answer” condition for the affected leg only (e.g., drop this leg). For a single leg call with a detected no answer condition, treat the same as value 0, <i>No Answer Call</i> .
	1	1							3	Reserved.
<i>None Reachable (NR) (octet 2, bit A)</i>										
Bits	H	G	F	E	D	C	B	A	Value	Meaning
								0	0	Member Not Reachable. Apply treatment for the last member not reachable for a detected busy, routing failure, no page response, or no answer condition local to the controlling system for the entire call.
								1	1	Group Not Reachable. Launch a RedirectionRequest or Transfer-ToNumberRequest for a group in which no members were reachable.

6.5.2.160 TransactionCapability

The TransactionCapability (TRANSCAP) parameter indicates a system's transaction capability at the current time (i.e., this capability may change over time).

Field	Value	Type	Reference	Notes					
Identifier	TransactionCapability IMPLICIT OCTET STRING	M	6.5.1.2						
Length	variable octets	M	6.5.1.1						
Contents									
H	G	F	E	D	C	B	A	octet	Notes
Reserved			SPINI	RUI	ANN	BUSY	PROF	1	a
Reserved			TL	Multiple Terminations				2	a
...								<i>n</i>	b

Figure 177 TransactionCapability parameter

Notes:

- a. Reserved bits shall be ignored on receipt and set to zero on sending.
- b. Ignore extra octets, if received. Send only defined (or significant) octets.

Table 192 TransactionCapability parameter

<i>Profile (PROF)</i> (octet 1, bit A)											
Bits	H	G	F	E	D	C	B	A	Value	Meaning	
									0	0	The system is not capable of supporting the <i>IS-41-C</i> profile parameters.
									1	1	The system is capable of supporting the <i>IS-41-C</i> profile parameters.
<i>Busy Detection (BUSY)</i> (octet 1, bit B)											
Bits	H	G	F	E	D	C	B	A	Value	Meaning	
									0	0	The system is not capable of detecting a busy condition at the current time.
									1	1	The system is capable of detecting a busy condition at the current time.
<i>Announcement (ANN)</i> (octet 1, bit C)											
Bits	H	G	F	E	D	C	B	A	Value	Meaning	
									0	0	The system is not capable of honoring the AnnouncementList parameter at the current time.
									1	1	The system is capable of honoring the AnnouncementList parameter at the current time.
<i>Remote User Interraction (RUI)</i> (octet 1, bit D)											
Bits	H	G	F	E	D	C	B	A	Value	Meaning	
									0	0	The system is not capable of interacting with the user.
									1	1	The system is capable of interacting with the user.
<i>Subscriber PIN Intercept (SPINI)</i> (octet 1, bit E)											
Bits	H	G	F	E	D	C	B	A	Value	Meaning	
									0	0	The system is not capable of supporting local SPINI operation at the current time.
									1	1	The system is capable of supporting local SPINI operation.
<i>Multiple Terminations</i> (octet 2, bits A-D)											
Bits	H	G	F	E	D	C	B	A	Value	Meaning	
					0	0	0	0	0	0	The system cannot accept a termination at this time (i.e., cannot accept routing information).
					0	0	0	1	1	} The system supports the number of call legs indicated.	
					through		
					1	1	1	1	15		
<i>TerminationList (TL)</i> (octet 2, bit E)											
Bits	H	G	F	E	D	C	B	A	Value	Meaning	
									0	0	The system is not capable of supporting the TerminationList parameter at the current time.
									1	1	The system is capable of supporting the TerminationList parameter at the current time.

6.5.2.161 TrunkStatus

The TrunkStatus (TRNKSTAT) parameter indicates the status of a designated trunk (e.g., either idle or blocked).

Field	Value	Type	Reference	Notes					
Identifier	TrunkStatus IMPLICIT Unsigned Enumerated	M	6.5.1.2						
Length	1 octet	M	6.5.1.1						
Contents									
H	G	F	E	D	C	B	A	octet	Notes
TrunkStatus								1	

Figure 178 TrunkStatus parameter

Table 193 TrunkStatus value

<i>TrunkStatus (octet 1)</i>										
Bits	H	G	F	E	D	C	B	A	Value	Meaning
	0	0	0	0	0	0	0	0	0	Idle.
	0	0	0	0	0	0	0	1	1	Blocked.
	0	0	0	0	0	0	1	0	2	} Reserved. Return a RETURN ERROR if a reserved value is used when this parameter appears in an INVOKE component. If a reserved value is used in a RETURN RESULT component, treat the reserved value the same as value 1, <i>Blocked</i> .
				...					through	
	1	1	0	1	1	1	1	1	223	
	1	1	1	0	0	0	0	0	224	} Reserved for <i>TIA/EIA-41</i> protocol extension. If unknown, treat the same as a reserved value (see above).
				...					through	
	1	1	1	1	1	1	1	1	255	

6.5.2.162 UniqueChallengeReport

The UniqueChallengeReport (UCHALRPT) parameter indicates the outcome of the Unique Challenge initiated by the AC or the VLR.

Field	Value	Type	Reference	Notes					
Identifier	UniqueChallengeReport IMPLICIT OCTET STRING	M	6.5.1.2						
Length	variable octets	M	6.5.1.1						
Contents									
H	G	F	E	D	C	B	A	octet	Notes
Unique Challenge Report								1	
...								<i>n</i>	<i>a</i>

Figure 179 UniqueChallengeReport parameter

Notes:

- a. Ignore extra octets, if received. Send only defined (or significant) octets.

Table 194 UniqueChallengeReport value

<i>Unique Challenge Report (octet 1)</i>										
Bits	H	G	F	E	D	C	B	A	Value	Meaning
	0	0	0	0	0	0	0	0	0	Not used.
	0	0	0	0	0	0	0	1	1	Unique Challenge not attempted.
	0	0	0	0	0	0	1	0	2	Unique Challenge no response.
	0	0	0	0	0	0	1	1	3	Unique Challenge successful.
	0	0	0	0	0	1	0	0	4	Unique Challenge failed.
	0	0	0	0	0	1	0	1	5	} Reserved. Treat the same as value 1, <i>Unique Challenge not attempted.</i>
				...					through	
	1	1	0	1	1	1	1	1	223	
	1	1	1	0	0	0	0	0	224	} Reserved for <i>TIA/EIA-41</i> protocol extension. If unknown, treat the same as value 1, <i>Unique Challenge not attempted.</i>
				...					through	
	1	1	1	1	1	1	1	1	255	

6.5.2.163 UpdateCount

The UpdateCount (UPDCOUNT) parameter is used to indicate that the CallHistoryCount (COUNT) update procedure shall be initiated.

Field	Value	Type	Reference	Notes					
Identifier	UpdateCount IMPLICIT Unsigned Enumerated	M	6.5.1.2						
Length	1 octet	M	6.5.1.1						
Contents									
H	G	F	E	D	C	B	A	octet	Notes
UpdateCount								1	

Figure 180 UpdateCount parameter

Table 195 UpdateCount value

<i>UpdateCount (octet 1)</i>										
Bits	H	G	F	E	D	C	B	A	Value	Meaning
	0	0	0	0	0	0	0	0	0	Not used.
	0	0	0	0	0	0	0	1	1	Update COUNT.
	0	0	0	0	0	0	1	0	2	} Reserved. Treat a reserved value the same as value 1, <i>Update COUNT</i> .
				...					through 223	
	1	1	0	1	1	1	1	1	224	} Reserved for <i>TIA/EIA-41</i> protocol extension. If unknown, treat a reserved value the same as value 1, <i>Update COUNT</i> .
	1	1	1	0	0	0	0	0	through 255	
	1	1	1	1	1	1	1	1	255	

6.5.2.164 VoiceMailboxNumber

The VoiceMailboxNumber (VMBOX) parameter contains a voice mailbox number. Note that an MS's voice mailbox number may be different from its MobileIdentificationNumber.

Field	Value	Type	Reference	Notes					
Identifier	VoiceMailboxNumber IMPLICIT DigitsType	M	6.5.1.2	a					
Length	variable octets	M	6.5.1.1						
Contents									
H	G	F	E	D	C	B	A	octet	Notes
Type of Digits								1	b
Nature of Number								2	c
Numbering Plan				Encoding				3	d, e
Number of Digits								4	f
2 nd BCD Digit				1 st BCD Digit				5	
4 th BCD Digit				3 rd BCD Digit				6	
...				
n^{th} BCD Digit				$n-1^{\text{st}}$ BCD Digit				m	

Figure 181 VoiceMailboxNumber parameter for BCD digits

Notes:

- a. Refer to the DigitsType parameter type (see 6.5.3.2) for notes and field encoding.
- b. The Type of Digits field is ignored on receipt.
- c. The Nature of Number field is ignored on receipt.
- d. The Numbering Plan field is ignored on receipt.
- e. The Encoding field is set to *BCD*.
- f. The Number of Digits is between 0 and at least 15.

6.5.2.165 VoiceMailboxPIN

The VoiceMailboxPIN (VMSPIN) parameter contains the Voice Message System personal identification number (PIN) for the designated subscriber.

Field	Value	Type	Reference	Notes					
Identifier	VoiceMailboxPIN IMPLICIT DigitsType	M	6.5.1.2	a					
Length	variable octets	M	6.5.1.1						
Contents									
H	G	F	E	D	C	B	A	octet	Notes
Type of Digits								1	b
Nature of Number								2	c
Numbering Plan				Encoding				3	d, e
Number of Digits								4	f
2 nd BCD Digit				1 st BCD Digit				5	
4 th BCD Digit				3 rd BCD Digit				6	
...				
n^{th} BCD Digit				$n-1^{\text{st}}$ BCD Digit				m	

Figure 182 VoiceMailboxPIN parameter for BCD digits

Notes:

- a. Refer to the DigitsType parameter type (see 6.5.3.2) for notes and field encoding.
- b. The Type of Digits field is ignored on receipt.
- c. The Nature of Number field is ignored on receipt.
- d. The Numbering Plan field is ignored on receipt.
- e. The Encoding field is set to *BCD*.
- f. The Number of Digits is between 0 and at least 15.

6.5.2.166 VoicePrivacyMask

The VoicePrivacyMask (VPMASK) parameter contains a 528-bit field consisting of two 260-bit masks used for Voice Privacy. For a TDMA digital traffic channel, VPMASK-A is for speech transferred in the inward direction (from the MS toward the MSC) and VPMASK-B is for speech transferred in the outward direction (from the MSC toward the MS).

For a CDMA digital traffic channel, the Private Long Code Mask is derived from the VPMASK-A and VPMASK-B.

These masks are calculated using CAVE parameters in effect when the call is established and remain constant for the duration of the call.

The presence of this optional parameter indicates Voice Privacy is possible for this MS; the current operational status of privacy is, however, defined by the ConfidentialityModes parameter (see 6.5.2.50).

Field	Value	Type	Reference	Notes					
Identifier	VoicePrivacyMask IMPLICIT OCTET STRING	M	6.5.1.2						
Length	66 octets	M	6.5.1.1						
Contents									
H	G	F	E	D	C	B	A	octet	Notes
Reserved				MSB				1	a
								2	
				VPMASK-A				3	
				
								32	
				LSB				33	
Reserved				MSB				34	a
								35	
				VPMASK-B				36	
				
								65	
				LSB				66	

Figure 183 VoicePrivacyMask parameter

Notes:

- a. Reserved bits shall be ignored on receipt and set to zero on sending.

6.5.2.J1 ChargingAreaInformation

The ChargingAreaInformation (CAINFO) parameter specifies the Charge Area digits in BCD format for Interconnection charge billing system.

Field	Value	Type	Reference	Notes					
Identifier	ChargingAreaInformation IMPLICIT OCTET STRING	M	6.5.1.2						
Length	<i>m</i> variable octets	M	6.5.1.1	a					
Contents									
H	G	F	E	D	C	B	A	Octet	Notes
Number of Digits								1	
2 nd CA Digit				1 st CA Digit				2	b, c
4 th CA Digit				3 rd CA Digit				3	b, c
...				b, c
<i>n</i> th CA Digit				<i>n</i> -1 st CA Digit				<i>m</i>	b, c

Figure J1 ChargingAreaInformation parameter

Notes:

- Where $m = 1 + \lceil (\text{Number of Digits})/2 \rceil$, rounded up to an integer] for this parameter type variant.
- When there is an odd number of digits, the $n^{\text{th}} + 1$ digit field is set to Filler (value = 0).
- The 1st CA Digit is the least significant digit and n^{th} CA Digit is the most significant digit.

Table J1 ChargingAreaInformation value

Digit <i>n</i> , where $n = \{1, 2, 3, \dots\}$ (octet 1- <i>m</i>)									
Bits	H	G	F	E		Value	Meaning		
or	D	C	B	A					
	0	0	0	0		0	Digit = 0 or filler.		
	0	0	0	1		1	Digit = 1.		
	0	0	1	0		2	Digit = 2.		
	0	0	1	1		3	Digit = 3.		
	0	1	0	0		4	Digit = 4.		
	0	1	0	1		5	Digit = 5.		
	0	1	1	0		6	Digit = 6.		
	0	1	1	1		7	Digit = 7.		
	1	0	0	0		8	Digit = 8.		
	1	0	0	1		9	Digit = 9.		
	X	X	X	X		-	Other values are reserved.		

6.5.2.J2 CarrierIdentificationCode

The CarrierIdentificationCode (CAIDCODE) parameter specifies the carrier identification code in BCD format for Interconnection charge billing system.

Field	Value	Type	Reference	Notes					
Identifier	CarrierIdentificationCode IMPLICIT OCTET STRING	M	6.5.1.2						
Length	<i>m</i> variable octets	M	6.5.1.1	a					
Contents									
H	G	F	E	D	C	B	A	octet	Notes
Number of Digits								1	
2 nd Digit				1 st Digit				2	b, c
4 th Digit				3 rd Digit				3	b, c
...				b, c
<i>n</i> th Digit				<i>n</i> -1 st Digit				<i>m</i>	b, c

Figure J2 CarrierIdentificationCode parameter

Notes:

- a. Where $m = 1 + [(Number\ of\ Digits)/2, \text{ rounded up to an integer}]$ for this parameter type variant.
- b. When there is an odd number of digits, the $n^{th} + 1$ digit field is set to Filler (value = 0).
- c. The 1st Digit is the least significant digit and n^{th} Digit is the most significant digit.

Table J2 CarrierIdentificationCode value

<i>Digitn, where n={1, 2, 3, ...}(octet 1-m)</i>									
Bits	H	G	F	E		Value	Meaning		
or	D	C	B	A					
	0	0	0	0		0	Digit = 0 or filler.		
	0	0	0	1		1	Digit = 1.		
	0	0	1	0		2	Digit = 2.		
	0	0	1	1		3	Digit = 3.		
	0	1	0	0		4	Digit = 4.		
	0	1	0	1		5	Digit = 5.		
	0	1	1	0		6	Digit = 6.		
	0	1	1	1		7	Digit = 7.		
	1	0	0	0		8	Digit = 8.		
	1	0	0	1		9	Digit = 9.		
	X	X	X	X		-	Other values are reserved.		

6.5.2.J3 MobileAdditionalParty'sCategory3

The MobileAdditionalParty'sCategory3 (MAPC3) parameter specifies information concerning communications system for a given subscriber. The MobileAdditionalParty'sCategory3 field has an allowed range of 0 to 255, in binary format. This parameter is used for Interconnection charge billing system.

Field	Value	Type	Reference	Notes					
Identifier	MobileAdditinalPartyCategory3 IMPLICIT OCTET STRING	M	6.5.1.2						
Length	1 octet	M	6.5.1.1						
Contents									
H	G	F	E	D	C	B	A	octet	Notes
MobileAdditionalParty'sCategory3								1	

Figure J3 MobileAdditionalParty'sCategory3 parameter

Table J3 MobileAdditionalParty'sCategory3 value

<i>MobileAdditionalParty'sCategory3 (octet 1)</i>										
Bits	H	G	F	E	D	C	B	A	Value	Meaning
	0	0	0	0	0	0	0	0	0	} Reserved for specific carrier use.(Note)
			...						through	
	1	1	1	1	1	1	1	1	255	Note : Defined by every carrier.

6.5.3 Parameter Type Definitions

This Section provides the definitions of the parameter types used in this Standard.

6.5.3.1. CHOICE

CHOICE is used to select one of mutually exclusive parameters. The encoded type identifier used is the chosen parameter type.

Optional CHOICES may be extended in future releases.

6.5.3.2. DigitsType

The DigitsType parameter type is based on the Digits parameter defined in Section 3 of *ANSI T1.114-1988*. Where there are differences, this Standard takes precedence.

New address parameters each use a unique and distinct identifier and an IMPLICIT DigitsType. This allows messages with multiple address parameters to be decoded by examining only the message identifiers.

The minimum length of this parameter type variant is 4 octets.

Field	Value	Type	Reference	Notes					
Identifier	DigitsType IMPLICIT OCTET STRING	M	6.5.1.2						
Length	m variable octets	M	6.5.1.1	a					
Contents									
H	G	F	E	D	C	B	A	octet	Notes
Type of Digits								1	
Nature of Number								2	
Numbering Plan				Encoding				3	
Number of Digits								4	
2 nd BCD Digit				1 st BCD Digit				5	
4 th BCD Digit				3 rd BCD Digit				6	
...				
n^{th} BCD Digit				$n-1^{\text{st}}$ BCD Digit				m	b

Figure 184 DigitsType parameter type variant for BCD digits

Notes:

- Where $m = 4 + [(Number\ of\ Digits)/2, \text{ rounded up to an integer}]$ for this parameter type variant.
- When there is an odd number of digits the n^{th} digit is set to *filler*.

The minimum length of this parameter type variant is 4 octets.

Field	Value	Type	Reference	Notes					
Identifier	DigitsType IMPLICIT OCTET STRING	M	6.5.1.2						
Length	<i>m</i> variable octets	M	6.5.1.1	a					
Contents									
H	G	F	E	D	C	B	A	octet	Notes
Type of Digits								1	
Nature of Number								2	
Numbering Plan				Encoding				3	
Number of Digits								4	
1 st IA5 Character								5	
2 nd IA5 Character								6	
...								...	
Last IA5 Character								<i>m</i>	

Figure 185 DigitsType parameter type variant for IA5 digits

Notes:

- a. Where $m = 4 + (\text{Number of Digits})$ for this parameter type variant.

The minimum length of this parameter type variant is 7 octets.

Field	Value	Type	Reference	Notes					
Identifier	DigitsType IMPLICIT OCTET STRING	M	6.5.1.2						
Length	<i>m</i> variable octets	M	6.5.1.1	a					
Contents									
H	G	F	E	D	C	B	A	octet	Notes
Type of Digits								1	
Nature of Number								2	
Numbering Plan				Encoding				3	
MSB								4	
IP Address								5	
IP Address								6	
IP Address								7	
								LSB	

Figure 186 DigitsType parameter type variant for IP address

Notes:

- a. Where $m = 7$ for this parameter type variant.

The minimum length of this parameter type variant is 7 octets.

Field	Value	Type	Reference	Notes					
Identifier	DigitsType IMPLICIT OCTET STRING	M	6.5.1.2						
Length	<i>m</i> variable octets	M	6.5.1.1	a					
Contents									
H	G	F	E	D	C	B	A	octet	Notes
Type of Digits								1	
Nature of Number								2	
Numbering Plan				Encoding				3	
Point Code								4	b
								5	
								6	
Subsystem Number (SSN)								7	

Figure 187 DigitsType parameter type variant for an SS7 point code address

Notes:

- a. Where $m = 7$ for this parameter type variant.
- b. The content of this field is as follows.

• ANSI

Point Code - Member Number	2
Point Code - Cluster Number	3
Point Code - Network Number	4

• TTC

Point Code	2
	3
Not used (all'0')	4

(Format of TTC-PC)

8	7	6	5	4	3	2	1	
S				M				Octet 1
LSB				MSB		LSB		
U								S
UB				UU				
MSB	LSB		MSB	LSB		MSB		

Table 196 DigitsType value

<i>Type of Digits (octet 1, bits A-H)</i>										
Bits	H	G	F	E	D	C	B	A	Value	Meaning
	0	0	0	0	0	0	0	0	0	Not Used.
	0	0	0	0	0	0	0	1	1	Dialed Number or Called Party Number .
	0	0	0	0	0	0	1	0	2	Calling Party Number .
	0	0	0	0	0	0	1	1	3	Caller Interaction . These are the digits dialed by a user in response to a prompt (not used in this Standard).
	0	0	0	0	0	1	0	0	4	Routing Number . This number is used to steer a call towards its ultimate destination.
	0	0	0	0	0	1	0	1	5	Billing Number . This is the number to use for ANI, Charge Number or other recording purposes.
	0	0	0	0	0	1	1	0	6	Destination Number . This is the network address of the called party.
	0	0	0	0	0	1	1	1	7	LATA (not used in this Standard).
	0	0	0	0	1	0	0	0	8	Carrier . In North America the three, four, or five digits represent an interexchange or international carrier.
	X	X	X	X	X	X	X	X	-	Other values are reserved.

#

Table 196 (continued)

<i>Nature of Number (octet 2, bits A-H_)</i>										
Bits	H	G	F	E	D	C	B	A	Value	Meaning
								0	-	National.
								1	-	International.
								0	-	Presentation Allowed.
								1	-	Presentation Restricted.
								0	-	Number is available.
								1	-	Number is not available.
			0	0					-	User provided, not screened.
			0	1					-	User provided, screening passed.
			1	0					-	User provided, screening failed.
			1	1					-	Network provided.
	X	X			X				-	Reserved.
<i>Encoding (octet 3, bits A-D)</i>										
Bits	H	G	F	E	D	C	B	A	Value	Meaning
					0	0	0	0	0	Not used.
					0	0	0	1	1	BCD (see Digit definition below).
					0	0	1	0	2	IA5. The International Alphabet 5 as defined in ITU-T <i>Rec. T.50</i> . (also known as the International Reference Alphabet (IRA)).
					0	0	1	1	3	Octet string. This is used for IP and SS7 addresses.
					X	X	X	X	-	Other values are reserved.
<i>Numbering Plan (octet 3, bits E-H)</i>										
Bits	H	G	F	E	D	C	B	A	Value	Meaning
		0	0	0	0				0	Unknown or not applicable.
		0	0	0	1				1	ISDN Numbering (not used in this Standard).
		0	0	1	0				2	Telephony Numbering (ITU-T <i>Rec. E.164, E.163</i>).
		0	0	1	1				3	Data Numbering (ITU-T <i>Rec. X.121</i>) (not used in this Standard).
		0	1	0	0				4	Telex Numbering (ITU-T <i>Rec. F.69</i>) (not used in this Standard).
		0	1	0	1				5	Maritime Mobile Numbering (not used in this Standard).
		0	1	1	0				6	Land Mobile Numbering (ITU-T <i>Rec. E.212</i>)
		0	1	1	1				7	Private Numbering Plan (service provider defined).
		1	1	0	1				13	SS7 Point Code (PC) and Subsystem Number (SSN).
		1	1	1	0				14	Internet Protocol (IP) Address.
		1	1	1	1				15	Reserved for extension.
	X	X	X	X					-	Other values are reserved.

Table 196 (concluded)

<i>Digit (octets 5-m)</i>						
Bits	H	G	F	E	Value	Meaning
or	D	C	B	A		
	0	0	0	0	0	Digit = 0 or filler.
	0	0	0	1	1	Digit = 1.
	0	0	1	0	2	Digit = 2.
	0	0	1	1	3	Digit = 3.
	0	1	0	0	4	Digit = 4.
	0	1	0	1	5	Digit = 5.
	0	1	1	0	6	Digit = 6.
	0	1	1	1	7	Digit = 7.
	1	0	0	0	8	Digit = 8.
	1	0	0	1	9	Digit = 9.
	1	0	1	0	-	Spare.
	1	0	1	1	-	Code 11.
	1	1	0	0	-	Code 12.
	1	1	0	1	-	*
	1	1	1	0	-	#.
	1	1	1	1	-	ST.

6.5.3.3. ENUMERATED

The ENUMERATED data type is encoded as an Integer using only the defined values. This is encoded as UNIVERSAL class, number 10.

An ENUMERATED value may be extended in future releases.

6.5.3.4. IMPLICIT

An identifier modified by "IMPLICIT" means that the identifier is used alone without the identifier of the contained parameter type, as it would be used in Abstract Syntax Notation One (ASN.1) from X.208 and the Basic Encoding Rules (BER) from X.209. For example:

Field	Value	Type	Reference	Notes					
Identifier	InterSwitchCount IMPLICIT Unsigned Integer (0..255)	M	6.5.1.2						
Length	1 octet	M	6.5.1.1						
Contents									
H	G	F	E	D	C	B	A	octet	Notes
InterSwitchCount								1	

Figure 188 InterSwitchCount parameter (IMPLICIT encoding)

and could be expressed using ASN.1 as:

```
interSwitchCount ::= [007] IMPLICIT UnsignedInteger
(0..255)
```

```
UnsignedInteger ::= IMPLICIT Integer (0..MAX) --
ignoring the use of the sign bit
```

which would be encoded using BER as (with a count value of 5):

Table 197 IMPLICIT Encoding of InterSwitchCount

Identifier	Length	Value
1000 0111 ₂	0000 0001 ₂	0000 0101 ₂
Context (10 ₂)	1 ₁₀	5 ₁₀
Primitive (0 ₂)		
InterSwitchCount (00111 ₂)		

Without using ‘IMPLICIT’ tags, the above example could be:

Field	Value	Type	Reference	Notes					
Identifier	InterSwitchCount INTEGER (0..255)	M	6.5.1.2						
Length	1 octet	M	6.5.1.1						
Contents									
H	G	F	E	D	C	B	A	octet	Notes
InterSwitchCount								1	

Figure 189 InterSwitchCount parameter (EXPLICIT encoding)

and could be expressed using ASN.1 as:

```
interSwitchCount ::= [007] Integer (0..255)
-- ignoring the use of the sign bit
```

which would be encoded using BER as (with a count value of 5):

Table 198 EXPLICIT Encoding of InterSwitchCount

Identifier	Length	Value		
		Identifier	Length	Value
1010 0111 ₂	0000 0011 ₂	0000 0010 ₂	0000 0001 ₂	0000 0101 ₂
Context (10 ₂)	3 ₁₀	Universal (00 ₂)	1 ₁₀	5 ₁₀
Constructed (1 ₂)		Primitive (0 ₂)		
InterSwitchCount (00111 ₂)		Integer (00010 ₂)		

Note that if the constructed type ‘‘Unsigned Integer’’ was used in the second example, there would have been another constructed identifier and length for the Unsigned Integer. This was omitted for the sake of simplicity.

1 Implicit tagging allows for more compact encoding. Explicit tagging allows for more
2 error checking.
3
4

5 **6.5.3.5. INTEGER**

7 The INTEGER data type specifies an integer per *X.209 Basic Encoding Rules*. That is:
8

- 9 1) the most significant bit of the first octet indicates the sign of the integer.
- 10 2) the most significant octet is sent first (i.e., the first octet).
- 11 3) the first octet shall not be all ones or all zeros if the value is more than one octet.
- 12 4) the maximum number of bits in this Standard, including the sign bit, is 32. This
13 may be increased in the future without violation of this Standard or *X.209*.
14 Individual instances may use a restricted range of values.
15
16
17

18 This is encoded as UNIVERSAL class, number 2.

19
20 The length of a fixed length integer may not be extended in future releases.
21
22
23
24

25 **6.5.3.6. NULL**

26 The NULL data type is encoded as a parameter identifier, a length of zero and no
27 contents octets. A NULL data type is allowed only when its meaning is explicitly stated.
28 This is encoded as UNIVERSAL class, number 5.
29
30

31 NULL or zero length parameters should not be used unless explicitly allowed and the
32 meaning of the NULL is defined.
33
34

35 **6.5.3.7. OCTET STRING**

36 The OCTET STRING data type is encoded as an *X.209* OCTET STRING type. This is
37 encoded as UNIVERSAL class, number 4.
38
39
40

41 The length of a fixed length octet string may not be extended in future releases. Fields
42 may be added to variable length octet strings. Defined field lengths may not, in general,
43 be extended.
44
45

46 **6.5.3.8. SEQUENCE**

47 The SEQUENCE data type is an *X.209* data type and is used to construct parameters
48 where the order of the contained parameters is significant. This is encoded as
49 UNIVERSAL class, number 16.
50
51

52 SEQUENCEs may be extended in future releases with new parameters added at the end
53 of existing sequences.
54
55
56
57
58
59
60

6.5.3.9. SEQUENCE OF

The SEQUENCE OF data type is an *X.209* data type and is used to construct parameters containing zero or more occurrences of the same parameter where the order of the parameters is significant. This is encoded as UNIVERSAL class, number 16 (the same as SEQUENCE).

6.5.3.10. SEQUENCE OF CHOICE

SEQUENCE OF CHOICE is used to encapsulate a group of parameters each of which may appear zero or more times, where the order of the parameters is significant. This is encoded as UNIVERSAL class, number 16.

Optional SEQUENCE OF CHOICES may be extended in future releases.

6.5.3.11. SET

The SET data type is an *X.209* data type and is used to construct parameters where the order of the contained parameters is insignificant. This is encoded as UNIVERSAL class, number 17.

SETs may be extended in future releases with new parameters added anywhere.

6.5.3.12. SET OF CHOICE

SET OF CHOICE is used to encapsulate a group of parameters each of which may appear zero or more times, where the order of the contained parameters is insignificant. This is encoded as UNIVERSAL class, number 17.

6.5.3.13. Subaddress

The Subaddress parameter type encodes the subaddress of a party of a call. The parameter encoding is based on the encoding of the information elements in *ANSI T1.607*.

Field	Value	Type	Reference	Notes					
Identifier	Subaddress IMPLICIT OCTET STRING	M	6.5.1.2						
Length	<i>n</i> variable octets	M	6.5.1.1						
Contents									
H	G	F	E	D	C	B	A	octet	Notes
1	Type of Subaddress			O/E	Reserved			1	a
Subaddress								2	b, c
...								3	
...								...	
...								<i>n</i>	

Figure 190 Subaddress parameter type

Notes:

- a. Reserved bits shall be ignored on receipt and set to zero on sending.
- b. The following applies to the contents of the Subaddress field when the Type of Subaddress = Network Service Access Point (NSAP):
 - The NSAP address shall be encoded using the preferred binary encoding specified in *CCITT Recommendation X.213* or *ISO 8348 AD2*. In this case, the subaddress field contains the Authority and Format Identifier (AFI).
 - When the AFI=50 (encoded in BCD as 0101 0000), IA5 characters are encoded as specified in Table 11 of *CCITT Recommendation T.50* or *ISO 646* with the eighth bit set to zero. When AFI=51 (encoded in BCD as 0101 0001), ASCII characters are encoded as specified in *ANSI X3.4* with the eighth bit set to zero.
- c. When the Type of Subaddress = User specified, the Subaddress field is encoded according to the user specification, subject to a maximum length of 20 octets. When interworking with *CCITT Recommendation X.25* networks, BCD coding should be applied.

Table 199 Subaddress value

<i>Odd/Even Indicator (O/E) (octet 1, bit D)</i>										
Bits	H	G	F	E	D	C	B	A	Value	Meaning
					0				-	Even number of subaddress signals follow.
					1				-	Odd number of subaddress signals follow.
<i>Type of Subaddress (octet 1, bits E-G)</i>										
Bits	H	G	F	E	D	C	B	A	Value	Meaning
		0	0	0					-	NSAP (<i>CCITT Rec. X.213</i> or <i>ISO 8348 AD2</i>)
		0	1	0					-	User specified.
		X	X	X					-	Other values are reserved.

6.5.3.14. Unsigned Enumerated

An Unsigned Enumerated value that is limited in range to non-negative values including zero. For the purposes of this Standard, the sign bit is considered part of the unsigned enumerated value. This type cannot be expressed as an ASN.1 ENUMERATED type, because an ENUMERATED type is encoded as an INTEGER which always uses the sign bit.

An Unsigned Enumerated value may be extended in future releases.

The length of a fixed length Unsigned Enumerated value may not be extended in future releases.

6.5.3.15. Unsigned Integer

An integer that is limited in range to non-negative values including zero. For the purposes of this Standard, the sign bit is considered part of the Unsigned Integer value. This type cannot be expressed as an ASN.1 INTEGER type, because an INTEGER always uses the sign bit.

7 MAP COMPATIBILITY GUIDELINES AND RULES

While the following sections outline guidelines and rules which will in the near term be beneficial to implementation of this standard, other activities which may impact these rules are in progress. As such, the remainder of Section 7, “MAP Compatibility Guidelines and Rules” may be subject to change and revision based on future *TIA/EIA-41* recommendations.

This is to ensure that there is no long term impediment to Cellular Radiotelecommunications networks to evolve and implement significant new functionality. Also, to better allow for the longer term alignment of *TIA/EIA-41* with emerging international standards.

7.1 ACHIEVING FORWARD COMPATIBILITY AND BACKWARD COMPATIBILITY

Following are some general considerations for enhancing and developing protocols.

7.1.1 Forward Compatibility

When developing a new protocol or enhancing an existing protocol, it is important to remember that a functional entity using one version of protocol may, in the future, need to communicate with functional entities using the enhanced version of the basic protocol. Hence, the protocol should be easy to enhance (e.g., easy to add new optional parameters). In addition, procedures should be built into the existing protocol to handle the situations when new messages, known messages with unknown parameters, or known parameters with unknown codes are received.

7.1.2 Backward Compatibility

When enhancing an existing protocol, it is important to keep in mind that a functional entity using one version of protocol may need to communicate with functional entities using older versions of same protocol. Hence, the protocol should not be changed abruptly into a form which the earlier protocol versions cannot even interpret. For example, one should not change a fixed length mandatory parameter to an optional parameter in an existing message.

7.2 GUIDELINES FOR FORWARD COMPATIBILITY

TIA/EIA-41 MAP shall contain a mechanism for forward compatibility. The following list and table contain the basic requirements of the mechanism:

- 1) These guidelines take precedence over the Abnormal Procedures section of TCAP (*ANSI TL.114-1988*, section 5).
- 2) Include the ability to send a TCAP REJECT component indicating that the received information was not understood when indicated by the following table.
- 3) Send this TCAP REJECT component to the functional entity that transmitted the confusing information if the necessary routing information is available.
- 4) For existing protocols, state the action to be taken on receipt of spare or reserved values of defined parameters (e.g., treat as appropriate default values). If no default is explicitly specified, the action listed in the following table should occur.
- 5) Only send messages that require an acknowledgment a limited number of times (e.g., 3). If no response is received, the sending functional entity should assume that the facility is not available and inform local management.
- 6) All messages may have new optional parameters added in any revision.

Table 200 Forward Compatibility Guidelines for Handling Incoming Messages and Parameters

	Problem	Response
1	Unrecognized Operation Code Identifier.	REJECT (Problem Specifier = <i>Unrecognized Operation Code</i>)
2	Unrecognized Package Type Identifier.	REJECT (Problem Specifier = <i>Unrecognized Package Type</i>)
3	Unrecognized Parameter Identifier at intermediate functional entity.	Transit parameter unchanged
4	Unrecognized Parameter Identifier at end functional entity.	Ignore parameter
5	Parameter with fixed length not the correct length.	REJECT (Problem Specifier = <i>IncorrectParameter</i>)
6	Variable length parameter has Parameter Length shorter than the minimum expected.	RETURN ERROR (Error Code = <i>ParameterError</i>)
7	Variable length parameter has Parameter Length longer than the maximum expected.	Ignore additional octets
8	Mandatory parameter missing.	REJECT (Problem Specifier = <i>IncorrectParameter</i>)
9	Optional parameter required by context of message is missing.	RETURN ERROR (Error Code = <i>MissingParameter</i>)
10	Optional parameter forbidden by presence or value of another parameter with stated precedence between them.	Ignore parameter
11	Optional parameter forbidden by presence of another parameter with no stated precedence.	RETURN ERROR (Error Code = <i>ParameterError</i>)
12	Parameter with known Parameter Identifier is not expected in this message.	Ignore parameter
13	Parameter value <i>Reserved</i> or <i>Not Used</i> .	Use default value, if specified, otherwise ignore parameter
14	Parameter value otherwise unrecognized or invalid.	RETURN ERROR (Error Code = <i>UnrecognizedParameterValue</i>)
15	Recognized parameter with valid values included more times than expected.	Ignore additional occurrences of parameter. This may indicate that a parameter that occurs once in the current revision of <i>TIA/EIA-41</i> is allowed to occur multiple times in a later revision. For compatibility, any single occurrence has to be acceptable.

7.3 GUIDELINES FOR BACKWARD COMPATIBILITY

All future revisions of *TIA/EIA-41* MAP from *IS-41* Revision B onward, shall contain a mechanism for backward compatibility. The following list contains the basic guidelines to be included.

7.3.1 Existing Messages

- 1) The ability of receiving any existing messages shall be possible, since the removal of a message implies the removal of a function.
- 2) The effect of receiving any existing message, parameter, or function in a new version, must be the same as that in previous versions. The effects of new parameters or parameter values will thus be purely additive.
- 3) For *TIA/EIA-41* the nature of a transaction shall not change to or from Unidirectional.

7.3.2 Parameters in Existing Messages

Message parameters in the Parameter Set¹ consist of 2 basic types, mandatory and optional, and need not occur in pre-defined order. All mandatory and optional parameters have variable length, although some parameters may have specified their length.

The following guidelines shall apply:

- 1) Optional parameters shall not become mandatory.
- 2) Mandatory parameters shall not become optional.
- 3) Additional mandatory parameters shall not be added to an existing message.
- 4) Additional optional parameters can be added to an existing message.
- 5) Existing mandatory parameters shall not be removed from existing messages.
- 6) The range of any parameter for an existing message shall not be reduced.
- 7) The meaning of any defined parameter value shall not be changed on an existing message.
- 8) There are no restrictions on the parameters for new messages.
- 9) The minimum length of the data portion of a variable length parameter is one octet, unless otherwise specified.
- 10) CHOICES may be extended (e.g., a CHOICE OF (ParameterA, ParameterB) may be extended to a CHOICE OF (ParameterA, ParameterB, ParameterC)).

¹Parameter Sequence is not used for *IS-41* MAP, therefore, will not be addressed here.

7.3.3 New Messages

- 1) New messages may be added after a recommendation has been published; however, functional entities that do not recognize these new messages will reject them, indicating that the information was not recognized.
- 2) The “information not recognized” message shall never be sent in response to a received “information not recognized” message (e.g., a REJECT message should never be sent in response to a received REJECT message), nor in response to other recognized messages received in the wrong call state. Appropriate default action shall be defined to handle these situations.

7.3.4 New Parameters

New optional parameters can be added to existing messages after a recommendation has been published; however, functional entities that do not recognize these new parameters could ignore them.

Addition of new parameters may be subjected to Basic Encoding Rules (BER) restrictions, as defined in 6.5.3.

7.3.5 New Parameter Fields

New fields may be added to, or spare fields may be used in existing parameters; however, functional entities that do not recognize these new fields may either respond with a message indicating that the information was not recognized or use the default values specified for these parameters.

7.3.6 New Parameter Values

Previously spare, reserved, or unallocated parameter values can be used. These will be treated at the receiving functional entity as defined in item 4 of Section 7.2.

1
2
3
4
5
6
7
8
9
10
11
12
13
14
15
16
17
18
19
20
21
22
23
24
25
26
27
28
29
30
31
32
33
34
35
36
37
38
39
40
41
42
43
44
45
46
47
48
49
50
51
52
53
54
55
56
57
58
59
60

(This page intentionally left blank.)

CELLULAR RADIOTELECOMMUNICATIONS INTERSYSTEM OPERATIONS:
CHAPTER 6
SIGNALING PROCEDURES

CONTENTS

1	LIST OF FIGURES.....	ix
2	LIST OF TABLES	x
3	FOREWORD	xii
4	REVISION HISTORY	xiii
5		
6	1 INTRODUCTION	1
7	1.1 OBJECTIVE.....	1
8	1.2 SCOPE	1
9	1.3 ORGANIZATION	1
10	1.4 DOCUMENTATION CONVENTIONS.....	2
11		
12	2 TECHNOLOGY AND CONCEPTS	5
13	2.1 INTERSYSTEM HANDOFF PROCEDURES	5
14	2.2 SHORT MESSAGE SERVICE PROCEDURES.....	6
15		
16	3 BASIC CALL PROCESSING.....	9
17	3.1 Registration Call Tasks	9
18	3.1.1 Autonomous or Power-On Registration	9
19	3.1.2 Power-Off Deregistration	9
20	3.1.3 Loading of Profile Parameters.....	10
21	3.2 Origination Call Tasks	12
22	3.2.1 Idle MS Origination	12
23	3.2.2 In Call MS Flash Attempt	14
24	3.2.3 MSC Analyze MS Dialed Number	15
25	3.2.4 HLR Analyze MS Dialed Number	19
26	3.2.5 Play All Announcements in the AnnouncementList	19
27	3.2.6 MSC Routing Points of Return.....	20
28	3.2.7 Originating Call Sent	22
29	3.2.8 Initialize the OneTimeFeatureIndicator Parameter	23
30	3.2.9 MSCActionCode Processing.....	24
31	3.3 Terminating Call Tasks	25
32	3.3.1 Incoming Call Attempt	25
33	3.3.2 Wait for TLDN Call.....	26
34	3.3.3 Page an MS Procedure.....	27
35	3.3.4 Authorize MS Termination Attempt.....	28
36	3.3.5 MS Termination Alerting.....	29
37	3.3.6 MSC Special MS Alerting.....	33
38	3.3.7 MSC Record the DMH Parameters.....	34
39	3.3.8 MSC Route the Call Leg Externally	35
40	3.4 Disconnect Call Tasks.....	39
41	3.4.1 MS Disconnect	39
42	3.4.2 Other Party Disconnect	39
43	3.4.3 Commanded Disconnect	39
44		
45		
46		
47		
48		
49		
50		
51		
52		
53		
54		
55		
56		
57		
58		
59		
60		

3.4.4	Apply Busy Treatment.....	40	1
3.4.5	Apply Access Denial Treatment.....	40	2
3.5	Recovery Call Tasks	41	3
3.5.1	Local Recovery Procedures	41	4
3.6	Handoff Call Tasks	41	5
3.6.1	Serving MSC Initiating a Handoff	41	6
			7
			8
4	INTERSYSTEM PROCEDURES.....	42	9
4.1	Authentication Directive	42	10
4.1.1	AC Initiation of an Authentication Directive.....	42	11
4.1.2	HLR Receiving AuthenticationDirective INVOKE	44	12
4.1.3	VLR Receiving AuthenticationDirective INVOKE	47	13
4.1.4	MSC Receiving AuthenticationDirective INVOKE	51	14
4.1.5	VLR Initiating an Authentication Directive	52	15
4.1.6	MSC Receiving Authentication Parameters	53	16
4.2	Authentication Directive Forward	58	17
4.2.1	Anchor MSC Initiating an Authentication Directive Forward.....	58	18
4.2.2	Serving MSC Receiving an AuthenticationDirectiveForward INVOKE	59	19
4.2.3	Tandem MSC Receiving an Authentication Directive Forward	61	20
4.3	Authentication Failure Report	61	21
4.3.1	MSC Initiating an Authentication Failure Report.....	61	22
4.3.2	VLR Receiving AuthenticationFailureReport INVOKE	63	23
4.3.3	HLR Receiving AuthenticationFailureReport INVOKE	67	24
4.3.4	AC Receiving AuthenticationFailureReport INVOKE	69	25
4.3.5	VLR Initiating an Authentication Failure Report	72	26
4.4	Authentication Request	75	27
4.4.1	MSC Initiating an Authentication Request.....	75	28
4.4.2	VLR Receiving AuthenticationRequest INVOKE.....	78	29
4.4.3	HLR Receiving AuthenticationRequest INVOKE.....	85	30
4.4.4	AC Receiving AuthenticationRequest INVOKE	87	31
			32
4.5	Authentication Status Report.....	92	33
4.5.1	MSC Initiating an Authentication Status Report	92	34
4.5.2	VLR Awaiting AuthenticationStatusReport INVOKE.....	93	35
4.5.3	HLR Receiving AuthenticationStatusReport INVOKE	98	36
4.5.4	AC Awaiting AuthenticationStatusReport INVOKE.....	100	37
4.6	Base Station Challenge.....	104	38
4.6.1	MSC Initiating a Base Station Challenge.....	104	39
4.6.2	VLR Receiving BaseStationChallenge INVOKE	104	40
4.6.3	HLR Receiving BaseStationChallenge INVOKE	106	41
4.6.4	AC Receiving BaseStationChallenge INVOKE	108	42
4.7	Blocking.....	109	43
4.8	Bulk Deregistration	110	44
4.8.1	VLR Initiating a Bulk Deregistration.....	110	45
4.8.2	HLR Receiving BulkDeregistration INVOKE	110	46
4.10	Count Request.....	111	47
4.10.1	AC Initiating a Count Request.....	111	48
4.10.2	HLR Receiving CountRequest INVOKE.....	112	49
4.10.3	VLR Receiving Count Request INVOKE	114	50
4.11	Facilities Directive (Handoff Forward).....	115	51
4.11.1	Serving MSC Initiating a Facilities Directive.....	115	52
4.11.2	Target MSC Receiving a FacilitiesDirective INVOKE.....	120	53
4.11.3	Target MSC Handoff Forward	122	54
			55
4.12	Facilities Directive 2	124	56
4.13	Facilities Release	124	57
4.13.1	MSC Initiation of Facilities Release	124	58
			59
			60

1		4.13.2	MSC Receiving FacilitiesRelease INVOKE	125
2	4.14		Feature Request	127
3		4.14.1	MSC Detecting Feature Request.....	127
4		4.14.2	VLR Receiving FeatureRequest INVOKE.....	129
5		4.14.3	HLR Receiving FeatureRequest INVOKE.....	130
6	4.15		Flash Request.....	138
7		4.15.1	Serving MSC Initiating a Flash Request	138
8		4.15.2	Anchor MSC Receiving a FlashRequest INVOKE.....	139
9		4.15.3	Tandem MSC Receiving of a Flash Request	141
10	4.16		Handoff Back (Shoe Lace Prevention).....	143
11		4.16.1	Serving MSC Initiating a Handoff Back	143
12		4.16.2	Target MSC Receiving a HandoffBack INVOKE	145
13		4.16.3	Target MSC Handoff Back.....	148
14				
15	4.17		Handoff Back 2.....	148
16	4.18		Handoff Measurement Request.....	148
17		4.18.1	Serving MSC Initiating a Handoff Measurement Request	148
18		4.18.2	Target MSC Receiving a HandoffMeasurementRequest INVOKE	149
19	4.19		Handoff Measurement Request 2.....	151
20		4.19.1	Serving MSC Initiating a Handoff Measurement Request 2	151
21		4.19.2	Target MSC Receiving a HandoffMeasurementRequest2 INVOKE	152
22	4.20		Handoff-to-Third (Path Minimization).....	154
23		4.20.1	Serving MSC Initiating a Handoff-To-Third.....	155
24		4.20.2	Tandem MSC Receiving a HandoffToThird INVOKE.....	157
25		4.20.3	Anchor MSC Receiving a HandoffToThird INVOKE.....	161
26		4.20.4	MSC Initiating a FacilitiesDirective for Path Minimization.....	164
27	4.21		Handoff-to-Third 2	166
28	4.22		Information Directive.....	166
29		4.22.1	HLR Initiating an Information Directive.....	166
30		4.22.2	VLR Receiving an InformationDirective INVOKE.....	166
31		4.22.3	MSC Receiving an InformationDirective INVOKE	168
32	4.23		Information Forward.....	170
33		4.23.1	MSC Initiating an Information Forward	170
34		4.23.2	MSC Receiving a InformationForward INVOKE	170
35	4.24		Intersystem Answer	173
36		4.24.1	MSC Awaiting InterSystemAnswer.....	173
37		4.24.2	MSC Initiating InterSystemAnswer.....	173
38	4.25		Intersystem Page.....	175
39		4.25.1	MSC Initiating an InterSystemPage.....	175
40		4.25.2	MSC Receiving InterSystemPage.....	177
41	4.26		Intersystem Page 2.....	180
42		4.26.1	MSC Initiating an InterSystemPage2.....	180
43		4.26.2	MSC Receiving InterSystemPage2.....	182
44	4.27		Intersystem Setup.....	185
45		4.27.1	MSC Initiating an Intersystem Setup	185
46		4.27.2	MSC Receiving InterSystemSetup INVOKE	186
47	4.28		Location Request	188
48		4.28.1	MSC Initiating a Location Request.....	188
49		4.28.2	HLR Receiving LocationRequest INVOKE.....	190
50	4.29		MS On Channel	195
51	4.30		MS Inactive	195
52		4.30.1	MSC Initiating an MS Inactive.....	195
53		4.30.2	VLR Receiving MSInactive INVOKE.....	196
54		4.30.3	VLR Detection of MS Inactivity.....	197
55		4.30.4	HLR Receiving MSInactive INVOKE.....	198
56		4.30.5	AC Receiving MSInactive INVOKE.....	199
57				
58				
59				
60				

4.31	Origination Request	201	1
4.31.1	MSC Initiating an Origination Request	201	2
4.31.2	HLR Receiving an OriginationRequest INVOKE	202	3
4.32	Qualification Directive	205	4
4.32.1	HLR Initiating a Qualification Directive.....	205	5
4.32.2	VLR Receiving QualificationDirective INVOKE	206	6
4.32.3	VLR Initiating a Qualification Directive.....	208	7
4.32.4	MSC Receiving QualificationDirective INVOKE	208	8
4.33	Qualification Request	210	9
4.33.1	MSC Initiating a Qualification Request	210	10
4.33.2	VLR Initiating a Qualification Request.....	211	11
4.33.3	VLR Receiving QualificationRequest INVOKE	212	12
4.33.4	HLR Receiving QualificationRequest INVOKE	216	13
4.34	Random Variable Request	218	14
4.34.1	MSC Initiating a Random Variable Request	218	15
4.34.2	MSC Receiving RandomVariableRequest INVOKE.....	219	16
4.35	Redirection Directive	220	17
4.35.1	MSC Initiating a Redirection Directive.....	220	18
4.35.2	MSC Receiving RedirectionDirective INVOKE	221	19
4.36	Redirection Request	223	20
4.36.1	MSC Initiating a Redirection Request.....	223	21
4.36.2	MSC Receiving RedirectionRequest INVOKE	224	22
4.37	Registration Cancellation	226	23
4.37.1	HLR Initiating Registration Cancellation.....	226	24
4.37.2	VLR Receiving RegistrationCancellation INVOKE.....	227	25
4.37.3	VLR Initiating Registration Cancellation.....	229	26
4.37.4	MSC Receiving RegistrationCancellation INVOKE	230	27
4.38	Registration Notification	233	28
4.38.1	MSC Initiating MS Registration	233	29
4.38.2	VLR Receiving RegistrationNotification INVOKE.....	235	30
4.38.3	HLR Receiving RegistrationNotification INVOKE.....	241	31
4.39	Remote User Interaction Directive.....	245	32
4.39.1	HLR Initiating a Remote User Interaction Directive.....	245	33
4.39.2	MSC Remote User Interaction	245	34
4.39.3	MSC Receiving a User Interaction Digit.....	249	35
4.40	Reset Circuit.....	249	36
4.41	Routing Request.....	250	37
4.41.1	HLR Initiating a Routing Request	250	38
4.41.2	VLR Receiving RoutingRequest INVOKE	251	39
4.41.3	MSC Receiving RoutingRequest INVOKE.....	254	40
4.44	SMS Delivery Backward.....	261	41
4.44.1	MSC Initiating SMS Delivery Backward.....	261	42
4.44.2	MSC Receiving an SMSDeliveryBackward INVOKE	262	43
4.45	SMS Delivery Forward	264	44
4.45.1	MSC Initiating SMS Delivery Forward	264	45
4.45.2	MSC Receiving an SMSDeliveryForward INVOKE.....	266	46
4.46	SMS Delivery Point-to-Point.....	267	47
4.46.1	SME Initiating SMS Delivery	267	48
4.46.2	Initiating SMS Delivery Point-To-Point	269	49
4.46.3	SME Receiving an SMSDeliveryPointToPoint INVOKE.....	271	50
4.46.4	MSC Receiving an SMSDeliveryPointToPoint INVOKE	273	51
4.46.5	Anchor MSC Initiating SMS Delivery Point-To-Point	277	52
4.46.6	MC Receiving an SMSDeliveryPointToPoint INVOKE	277	53
4.46.7	Originating MC Supplementary Services.....	279	54
4.46.8	Terminating MC Supplementary Services.....	280	55
			56
			57
			58
			59
			60

1		4.46.9	MC Initiating SMS Delivery Point-To-Point to an MS-Based SME	281
2		4.46.10	SMS Router Receiving an SMSDeliveryPointToPoint INVOKE.....	282
3	4.47		SMS Notification	285
4		4.47.1	HLR Initiating SMSNotification INVOKE.....	285
5		4.47.2	MSC Initiating SMS Notification	285
6		4.47.3	MC Receiving an SMSNotification INVOKE.....	286
7	4.48		SMS Request	288
8		4.48.1	MC Initiating SMS Request	288
9		4.48.2	HLR Receiving an SMSRequest INVOKE	289
10		4.48.3	VLR Receiving an SMSRequest INVOKE	292
11		4.48.4	MSC Receiving an SMSRequest INVOKE.....	294
12	4.49		Transfer-To-Number Request.....	296
13		4.49.1	MSC Initiating a Transfer-To-Number Request	296
14		4.49.2	HLR Receiving TransferToNumberRequest INVOKE.....	298
15	4.50		Trunk Test	302
16	4.51		Trunk Test Disconnect	302
17	4.52		Unblocking.....	302
18	4.53		Unreliable Roamer Data Directive.....	302
19		4.53.1	HLR Initiating a Unreliable Roamer Data Directive.....	302
20		4.53.2	VLR Receiving UnreliableRoamerDataDirective INVOKE	303
21	4.54		Unsolicited Response	304
22		4.54.1	MSC Detecting an Unsolicited Page Response	304
23		4.54.2	MSC Receiving UnsolicitedResponse INVOKE.....	305
24				
25				
26	5		VOICE FEATURE PROCEDURES	308
27		5.1	Call Delivery (CD).....	308
28		5.1.1	HLR CD Activation	308
29		5.1.2	HLR CD De-Activation	308
30		5.1.3	HLR CD Incoming Call Invocation	309
31		5.2	Call Forwarding—Busy (CFB).....	315
32		5.2.1	HLR CFB Registration	315
33		5.2.2	HLR CFB De-Registration	316
34		5.2.3	HLR CFB Activation	316
35		5.2.4	HLR CFB De-Activation	317
36		5.2.5	HLR CFB Busy MS Invocation.....	317
37		5.3	Call Forwarding—Default (CFD).....	318
38		5.3.1	HLR CFD Registration	318
39		5.3.2	HLR CFD De-Registration.....	319
40		5.3.3	HLR CFD Activation	319
41		5.3.4	HLR CFD De-Activation	320
42		5.3.5	HLR CFD Incoming Call Invocation	320
43		5.3.6	HLR CFD Inactive MS Invocation	321
44		5.3.7	HLR CFD Unavailable MS Invocation	321
45		5.3.8	HLR CFD Unresponsive MS Invocation	321
46		5.3.9	HLR CFD Busy MS Invocation	321
47		5.3.10	HLR CFD No Answer MS Invocation	321
48		5.3.11	HLR CFD Unroutable MS Invocation	322
49		5.4	Call Forwarding—No Answer (CFNA).....	322
50		5.4.1	HLR CFNA Registration.....	322
51		5.4.2	HLR CFNA De-Registration	323
52		5.4.3	HLR CFNA Activation	323
53		5.4.4	HLR CFNA De-Activation	324
54		5.4.5	HLR CFNA Incoming Call Invocation Task.....	324
55		5.4.6	HLR CFNA Inactive MS Invocation	325
56		5.4.7	HLR CFNA Unavailable MS Invocation	325
57				
58				
59				
60				

5.4.8	HLR CFNA Unresponsive MS Invocation.....	325	1
5.4.9	HLR CFNA No Answer MS Invocation	326	2
5.4.10	HLR CFNA Unroutable MS Invocation	326	3
5.5	Call Forwarding—Unconditional (CFU).....	326	4
5.5.1	HLR CFU Registration	326	5
5.5.2	HLR CFU De-Registration.....	327	6
5.5.3	HLR CFU Activation	327	7
5.5.4	HLR CFU De-Activation	328	8
5.5.5	HLR CFU Incoming Call Invocation	329	9
5.5.6	HLR CFU Unconditional MS Invocation.....	329	10
5.6	Call Transfer (CT)	329	11
5.7	Call Waiting (CW).....	330	12
5.7.1	HLR CW Activation	330	13
5.7.2	HLR CW De-Activation	330	14
5.7.3	HLR CW Temporary De-Activation.....	330	15
5.7.4	MSC CW Terminating Call Invocation.....	331	16
5.7.5	MSC CW Processing for Flash Request.....	332	17
5.8	Calling Number Identification Presentation (CNIP)	332	18
5.8.1	HLR CNIP Terminating Call Invocation	332	19
5.8.2	HLR CNIP Redirecting Call Invocation	333	20
5.8.3	MSC CNIP Originating Call Invocation	333	21
5.8.4	MSC CNIP Terminating Call Invocation	334	22
5.8.5	MSC CNIP Redirecting Call Invocation	335	23
5.9	Calling Number Identification Restriction (CNIR).....	335	24
5.9.1	HLR CNIR Temporary Activation	335	25
5.9.2	HLR CNIR Temporary De-Activation	336	26
5.9.3	MSC CNIR Originating Call Invocation.....	336	27
5.9.4	MSC CNIR Redirecting Call Invocation.....	336	28
5.10	Conference Calling (CC).....	337	29
5.10.1	HLR CC Invocation	337	30
5.10.2	HLR CC Drop Last Party Invocation	338	31
5.10.3	MSC CC Invocation.....	338	32
5.11	Do Not Disturb (DND).....	338	33
5.11.1	HLR DND Activation	338	34
5.11.2	HLR DND De-Activation	339	35
5.11.3	HLR DND Incoming Call Invocation	339	36
5.12	Flexible Alerting (FA).....	339	37
5.12.1	HLR FA Membership Activation	339	38
5.12.2	HLR FA Membership De-Activation.....	340	39
5.12.3	HLR FA Incoming Call Invocation	341	40
5.12.4	HLR FA Revertive Call Invocation	345	41
5.12.5	HLR FA Busy MS Invocation	346	42
5.12.6	HLR FA Inactive MS Invocation.....	348	43
5.12.7	HLR FA Unavailable MS Invocation	348	44
5.12.8	HLR FA Unresponsive MS Invocation	348	45
5.12.9	HLR FA No Answer MS Invocation	348	46
5.12.10	HLR FA Unroutable MS Invocation.....	348	47
5.13	Message Waiting Notification (MWN)	348	48
5.13.1	HLR MWN Demand Pip Tone Activation	348	49
5.13.2	HLR MWN Demand Pip Tone De-Activation	349	50
5.13.3	HLR MWN Pip Tone Temporary De-Activation	349	51
5.13.4	HLR MWN Demand Alert Pip Tone Activation	350	52
5.13.5	HLR MWN Demand Alert Pip Tone De-Activation.....	350	53
5.13.6	HLR MWN Status Change Invocation.....	350	54
5.13.7	MSC MWN Call Origination Invocation	351	55

1
2
3
4
5
6
7
8
9
10
11
12
13
14
15
16
17
18
19
20
21
22
23
24
25
26
27
28
29
30
31
32
33
34
35
36
37
38
39
40
41
42
43
44
45
46
47
48
49
50
51
52
53
54
55
56
57
58
59
60

1		5.13.8	MSC MWN Call Termination Invocation	351
2		5.13.9	MSC MWN Status Change Invocation	351
3	5.14	Mobile Access Hunting (MAH).....	352	
4		5.14.1	HLR MAH Demand Ordering	352
5		5.14.2	HLR MAH Membership Activation	354
6		5.14.3	HLR MAH Membership De-Activation.....	355
7		5.14.4	HLR MAH Incoming Call Invocation	356
8		5.14.5	HLR MAH Revertive Call Invocation	359
9		5.14.6	HLR MAH Busy MS Invocation	359
10		5.14.7	HLR MAH Inactive MS Invocation.....	361
11		5.14.8	HLR MAH Unavailable MS Invocation	361
12		5.14.9	HLR MAH Unresponsive MS Invocation	361
13		5.14.10	HLR MAH No Answer MS Invocation	361
14		5.14.11	HLR MAH Unroutable MS Invocation.....	361
15	5.15	Password Call Acceptance (PCA).....	362	
16		5.15.1	HLR PCA Diversion Number Registration	362
17		5.15.2	HLR PCA Diversion Number De-Registration	362
18		5.15.3	HLR PCA Password Registration	363
19		5.15.4	HLR PCA Password De-Registration	363
20		5.15.5	HLR PCA Activation	364
21		5.15.6	HLR PCA De-Activation	365
22		5.15.7	HLR PCA Incoming Call Invocation	365
23	5.16	Preferred Language (PL)	366	
24		5.16.1	HLR PL Language Registration	366
25	5.17	Priority Access and Channel Assignment (PACA).....	367	
26		5.17.1	HLR PACA Per Call Invocation.....	367
27		5.17.2	MSC PACA Call Origination Invocation.....	367
28	5.18	Remote Feature Control (RFC).....	369	
29		5.18.1	HLR RFC Incoming Call Invocation	369
30	5.19	Selective Call Acceptance (SCA)	375	
31		5.19.1	HLR SCA Diversion Number Registration	375
32		5.19.2	HLR SCA Diversion Number De-Registration	376
33		5.19.3	HLR SCA Number Registration	376
34		5.19.4	HLR SCA Number De-Registration	377
35		5.19.5	HLR SCA Activation	378
36		5.19.6	HLR SCA De-Activation	379
37		5.19.7	HLR SCA Incoming Call Invocation	379
38	5.20	Subscriber PIN Access (SPINA).....	380	
39		5.20.1	HLR SPINA Registration.....	380
40		5.20.2	HLR SPINA Activation	382
41		5.20.3	HLR SPINA De-Activation.....	383
42	5.21	Subscriber PIN Intercept (SPINI)	384	
43		5.21.1	HLR SPINI Registration	384
44		5.21.2	HLR SPINI Originating Call Invocation	386
45		5.21.3	MSC SPINI Originating Call Invocation	387
46		5.21.4	HLR SPINI Feature Request Invocation	388
47	5.22	Three-Way Calling (3WC).....	389	
48	5.23	Voice Message Retrieval (VMR).....	389	
49		5.23.1	HLR VMR VoiceMailboxPIN Registration	389
50		5.23.2	HLR VMR Invocation	391
51		5.23.3	HLR VMR Revertive Call Invocation	396
52	5.24	Voice Privacy (VP).....	396	
53				
54				
55				
56	6	COMMON VOICE FEATURE PROCEDURES	397	
57	6.1	Call Forwarding Routing.....	397	
58				
59				
60				

6.1.1	HLR Select Forward-To or Diversion Number Courtesy Call Point of Return	397	1
			2
6.1.2	HLR Select Forward-To or Diversion Number Point of Return	397	3
6.2	Digit Analysis	398	4
6.2.1	Termination Address Expansion	398	5
			6
7	OPERATION TIMER VALUES	400	7
			8
A	ANNEX A: Procedures for RANDC Verification	406	9
			10
B	ANNEX B: Procedures for SSD Management at AC	407	11
			12
C	ANNEX C: Authentication Response Verification	409	13
			14
D	ANNEX D: SMS Air Interface Delivery Point-to-Point	411	15
D.1	MSC Initiating SMD-REQUEST Toward an MS-Based SME	412	16
D.2	MS-Based SME Receiving an SMD-REQUEST	414	17
D.3	MSC Receiving an Unexpected SMD-ACK or SMD-NAK	415	18
D.4	MS-Based SME Initiating SMD-REQUEST Toward an MSC	415	19
D.5	Serving MSC Receiving an SMD-REQUEST	416	20
D.6	MS-Based SME Receiving an Unexpected SMD-ACK or SMD-NAK	418	21
			22
			23
E	ANNEX E: Global Service Logic	419	24
E.1	Introduction	419	25
E.2	GSL Diagram Conventions	420	26
E.3	GSLs	420	27
E.3.1	Call Origination GSL	421	28
E.3.2	In-Call Flash Attempt GSL	423	29
E.3.3	Feature Code GSL	425	30
E.3.4	Incoming Call Attempt GSL	427	31
E.3.5	Incoming MDN Call Attempt GSL	429	32
E.3.6	Incoming FA Call Attempt GSL	431	33
E.3.7	Incoming MAH Call Attempt GSL	433	34
E.3.8	Incoming MS Call Attempt GSL	435	35
E.3.9	Incoming RFC Call Attempt GSL	436	36
E.3.10	Busy MS Detected GSL	439	37
E.3.11	Busy Re-Routing GSL	441	38
E.3.12	Waitable MS Detected GSL	443	39
E.3.13	Inactive MS Detected GSL	445	40
E.3.14	Inactive Re-Routing GSL	447	41
E.3.15	Unavailable MS Detected GSL	449	42
E.3.16	Unavailable Re-Routing GSL	451	43
E.3.17	Unresponsive MS Detected GSL	453	44
E.3.18	Unresponsive Re-Routing GSL	455	45
E.3.20	Unroutable Call Detected GSL	457	46
E.3.20	Unroutable Call Re-Routing GSL	459	47
E.3.21	No Answer Call Re-Routing GSL	461	48
			49
			50
			51
F	ANNEX F: Signal Strength Arbitration	463	52
F.1	RegistrationCancellation Race Condition Algorithm	463	53
F.2	Timer Method to Detect Duplicate RegistrationNotification	464	54
F.3	Time Stamp Method to Detect Duplicate RegistrationNotification	466	55
			56
			57
			58
			59
			60

1
2
3
4
5
6
7
8
9
10
11
12
13
14
15
16
17
18
19
20
21
22
23
24
25
26
27
28
29
30
31
32
33
34
35
36
37
38
39
40
41
42
43
44
45
46
47
48
49
50
51
52
53
54
55
56
57
58
59
60

LIST OF FIGURES

- Figure 1 Document Organization2
- Figure 2 MS Originated SMS Delivery Point-to-Point Messages6
- Figure 3 Originating SMS Delivery Point-to-Point Procedures6
- Figure 4 MS Terminated SMS Delivery Point-to-Point Messages.....7
- Figure 5 Terminating SMS Delivery Point-to-Point Procedures.....7
- Figure 6 Message Center Processing of SMS Delivery Point-to-Point Messages.....8
- Figure 7 Message Center SMS Delivery Point-to-Point Procedures8
- Figure 8 Diagrammatic Conventions.....420
- Figure 9 Origination Detected GSL (MSC).....421
- Figure 10 In-Call Flash Attempt GSL (MSC).....423
- Figure 11 Incoming Feature Code GSL (HLR).....425
- Figure 12 Incoming Call Attempt GSL (MSC).....427
- Figure 13 Incoming MDN Call Attempt GSL (MSC).....429
- Figure 14 Incoming FA Call Attempt GSL (HLR)431
- Figure 15 Incoming MAH Call Attempt GSL (HLR)433
- Figure 16 Incoming MS Call Attempt GSL (HLR).....435
- Figure 17 Incoming RFC Call Attempt GSL (HLR)437
- Figure 18 Busy MS Detected GSL (HLR).....439
- Figure 19 Busy Re-Routing GSL (HLR)441
- Figure 20 Reach Waitable MS GSL (HLR).....443
- Figure 21 Inactive MS Detected GSL (HLR)445
- Figure 22 Inactive MS Re-Routing GSL (HLR)447
- Figure 23 Unavailable MS Detected GSL (HLR)449
- Figure 24 Unavailable MS Re-Routing GSL (HLR)451
- Figure 25 Unresponsive MS Detected GSL (HLR).....453
- Figure 26 Unresponsive MS Re-Routing GSL (HLR).....455
- Figure 27 Unroutable Call Detected GSL (HLR).....457
- Figure 28 Unroutable Call Re-Routing GSL (HLR)459
- Figure 29 No Answer Call Re-Routing GSL (HLR)461
- Figure 30 Multiple registrations received at the HLR (timer method)466
- Figure 31 Multiple registrations received at the HLR (time stamp method).....469

LIST OF TABLES

Table 1	HLR AuthenticationDirective Response	46
Table 2	VLR AuthenticationDirective Response	50
Table 3	MSC AuthenticationDirective Response	51
Table 4	Serving MSC AuthenticationDirectiveForward Response	60
Table 5	VLR AuthenticationFailureReport Response	66
Table 6	HLR AuthenticationFailureReport Response	68
Table 7	AC AuthenticationFailureReport Response	71
Table 8	VLR AuthenticationRequest Response	84
Table 9	HLR AuthenticationRequest Response	86
Table 10	AC AuthenticationRequest Response	91
Table 11	VLR AuthenticationStatusReport Response	97
Table 12	HLR AuthenticationStatusReport Response	99
Table 13	AC AuthenticationStatusReport Response	103
Table 14	VLR BaseStationChallenge Response	106
Table 15	HLR BaseStationChallenge Response	108
Table 16	AC BaseStationChallenge Response	109
Table 17	HLR BulkDeregistration Response	111
Table 18	HLR CountRequest Response	113
Table 19	VLR CountRequest Response	115
Table 20	Target MSC FacilitiesDirective Response	122
Table 21	Receiving MSC FacilitiesRelease Response	126
Table 22	HLR FeatureRequest Response	137
Table 23	Anchor MSC FlashRequest Response	140
Table 24	Tandem MSC FlashRequest Response	142
Table 25	Target MSC HandoffBack Response	147
Table 26	Target MSC HandoffMeasurementRequest Response	150
Table 27	Target MSC HandoffMeasurementRequest2 Response	154
Table 28	Tandem MSC HandoffToThird Response	160
Table 29	Anchor MSC HandoffToThird Response	163
Table 30	VLR InformationDirective Response	168
Table 31	MSC InformationDirective Response	169
Table 32	Serving MSC InformationForward Response	172
Table 33	Anchor MSC InterSystemAnswer Response	174
Table 34	Border MSC InterSystemPage Response	179
Table 35	Border MSC InterSystemPage2 Response	184
Table 36	Border MSC InterSystemSetup Response	187
Table 37	HLR LocationRequest Response	194
Table 38	VLR MSInactive Response	196
Table 39	HLR MSInactive Response	199
Table 40	AC MSInactive Response	200
Table 41	HLR OriginationRequest Response	204
Table 42	VLR QualificationDirective Response	207
Table 43	MSC QualificationDirective Response	209
Table 44	VLR QualificationRequest Response	215

1
2
3
4
5
6
7
8
9
10
11
12
13
14
15
16
17
18
19
20
21
22
23
24
25
26
27
28
29
30
31
32
33
34
35
36
37
38
39
40
41
42
43
44
45
46
47
48
49
50
51
52
53
54
55
56
57
58
59
60

1	Table 45	HLR QualificationRequest Response	217
2	Table 46	MSC RandomVariableRequest (RANDREQ) Response	220
3	Table 47	Originating MSC RedirectionDirective Response	222
4	Table 48	Originating MSC RedirectionRequest Response	225
5	Table 49	VLR RegistrationCancellation Response	229
6	Table 50	MSC RegistrationCancellation Response	232
7	Table 51	VLR RegistrationNotification Response	240
8	Table 52	HLR RegistrationNotification Response	244
9	Table 53	MSC RemoteUserInteractionDirective Response	248
10	Table 54	VLR RoutingRequest Response	253
11	Table 55	MSC RoutingRequest Response	260
12	Table 56	MC SMSNotification Response	287
13	Table 57	HLR SMSRequest Response	291
14	Table 58	VLR SMSRequest Response	293
15	Table 59	MSC SMSRequest Response	295
16	Table 60	HLR TransferToNumberRequest Response	301
17	Table 61	VLR UnreliableRoamerDataDirective Response	303
18	Table 62	Neighboring MSC UnsolicitedPageResponse Response	307
19	Table 63	Operation Timer Values	400
20	Table 64	SMD-REQUEST Parameters	411
21	Table 65	SMD-ACK Parameters	411
22	Table 66	SMD-NAK Parameters	412
23	Table 67	Mapping of Air Interface Parameters to SMD-REQUEST, SMS- ACK, and SMD-NAK Parameters	412
24	Table 68	Origination Detected GSL (MSC)	422
25	Table 69	In-Call Flash Attempt GSL (MSC)	424
26	Table 70	Incoming Feature Code GSL (HLR)	426
27	Table 71	Incoming Call Attempt GSL (MSC)	428
28	Table 72	Incoming MDN Call Attempt GSL (MSC)	430
29	Table 73	Incoming FA Call Attempt GSL (HLR)	432
30	Table 74	Incoming MAH Call Attempt GSL (HLR)	434
31	Table 75	Incoming MS Call Attempt GSL (HLR)	436
32	Table 76	Incoming RFC Call Attempt GSL (HLR)	438
33	Table 77	Busy MS Detected GSL (HLR)	440
34	Table 78	Busy Re-Routing GSL (HLR)	442
35	Table 79	Reach Waitable MS GSL (HLR)	444
36	Table 80	Inactive MS Detected GSL (HLR)	446
37	Table 81	Inactive MS Re-Routing GSL (HLR)	448
38	Table 82	Unavailable MS Detected GSL (HLR)	450
39	Table 83	Unavailable MS Re-Routing GSL (HLR)	452
40	Table 84	Unresponsive MS Detected GSL (HLR)	454
41	Table 85	Unresponsive MS Re-Routing GSL (HLR)	456
42	Table 86	Unroutable Call Detected GSL (HLR)	458
43	Table 87	Unroutable Call Re-Routing GSL (HLR)	460
44	Table 88	No Answer Call Re-Routing GSL (HLR)	462
45			
46			
47			
48			
49			
50			
51			
52			
53			
54			
55			
56			
57			
58			
59			
60			

FOREWORD

This Foreword is not part of this Standard.

This is one of a series of recommendations entitled:

“Cellular Radiotelecommunications Intersystem Operations”

which describe procedures necessary to provide to cellular radio telephone subscribers certain services requiring interaction between different cellular systems.

It is the intention of TIA/EIA TR-45.2 Subcommittee, Intersystem Operations, that this series of recommendations address the ongoing and developing concerns of the Cellular Radiotelecommunications Industry—subscribers, service providers and manufacturers alike—with regard to useful and effective services requiring standardized intersystem procedures.

The recommendations included in this series are:

- Chapter 1, *Cellular Radiotelecommunications Intersystem Operations: Functional Overview*
- Chapter 2, *Cellular Radiotelecommunications Intersystem Operations: Intersystem Handoff Information Flows*
- Chapter 3, *Cellular Radiotelecommunications Intersystem Operations: Automatic Roaming Information Flows*
- Chapter 4, *Cellular Radiotelecommunications Intersystem Operations: Operations, Administration, and Maintenance Information Flows and Procedures*
- Chapter 5, *Cellular Radiotelecommunications Intersystem Operations: Signaling Protocols*
- Chapter 6, *Cellular Radiotelecommunications Intersystem Operations: Signaling Procedures*

This edition of the Standard replaces *IS-41-C* which differs from the previous edition (i.e., *IS-41-B*) in its support of the following functionality:

- Intersystem Authentication and Encryption (supersedes *TSB51*)
- Intersystem Operations for Dual-mode CDMA Terminals (supersedes *TSB64*)
- Border Cell Problem Resolution (supersedes *TSB65*)
- Expanded Feature Support (i.e., for features defined in *TIA/EIA-664*.)
- Technical Clarifications and Compatibility (as per *TSB41* and *TSB55*)

REVISION HISTORY

Revision	Date	Remarks
<i>(IS-41)0</i>	February 1988	Initial publication
<i>(IS-41)A</i>	January 1991	
<i>(IS-41)B</i>	December 1991	
<i>(IS-41)C</i>	February 1996	
D	December 1997	Initial ANSI publication

1
2
3
4
5
6
7
8
9
10
11
12
13
14
15
16
17
18
19
20
21
22
23
24
25
26
27
28
29
30
31
32
33
34
35
36
37
38
39
40
41
42
43
44
45
46
47
48
49
50
51
52
53
54
55
56
57
58
59
60

1
2
3
4
5
6
7
8
9
10
11
12
13
14
15
16
17
18
19
20
21
22
23
24
25
26
27
28
29
30
31
32
33
34
35
36
37
38
39
40
41
42
43
44
45
46
47
48
49
50
51
52
53
54
55
56
57
58
59
60

(This page intentionally left blank.)

1 INTRODUCTION

1.1 OBJECTIVE

This document presents the recommendation by which a roaming cellular subscriber may be provided with “Automatic Roaming,” defined to comprise the following mechanisms:

- 1) Making the identity of the current serving, or visited system known to the home system.
- 2) Establishing financial responsibility for the roaming subscriber.
- 3) Establishing a valid roamer service profile in a visited system.
- 4) Providing for voice features and Short Message Services to the subscriber and providing of those feature and services while the subscriber is roaming.

The transactions are automatic in the sense that they operate in a manner that requires minimal intervention on the part of both the cellular subscriber and parties attempting to place a call to a cellular subscriber.

1.2 SCOPE

This document describes the signaling and call processing procedures required to perform automatic roaming features and services. The messages required to perform the automatic roaming are defined in Chapter 5.

Conformance with this chapter of this Standard shall mean that a system’s externally visible behavior is the same as the externally visible behavior of the abstract system described here.

1.3 ORGANIZATION

This document is organized as follows:

- 1) Section 1, entitled “Introduction,” provides an introduction to the document.
- 2) Section 2, entitled “Concepts and Technology,” provides an introduction into the methodology used to describe the Stage 3 Procedures.
- 3) Section 3, entitled “Basic Call Processing,” describes the basic call processing states, transitions, actions and the detection points for feature processing.
- 4) Section 4, entitled “Intersystem Procedures,” describes the procedures used between systems for handoff, mobility management, authentication, voice services and short message services.
- 5) Section 5, entitled “Voice Feature Procedures,” describes the procedures for individual voice feature control.
- 6) Section 6, entitled “Common Voice Feature Procedures,” describes common procedures for voice feature control.
- 7) Section 7, entitled “Operation Timer Values,” summarizes the operation timers used.

Sections 3 and 4 form the foundation for the procedures by specifying various call processing actions. Section 5 defines the procedures for all intersystem operations. Sections

5 and 6 uses the intersystem operations to build various voice features. (Short Message Service Feature procedures are for further study.) The organization and relationship of the sections is shown in the figure 1.

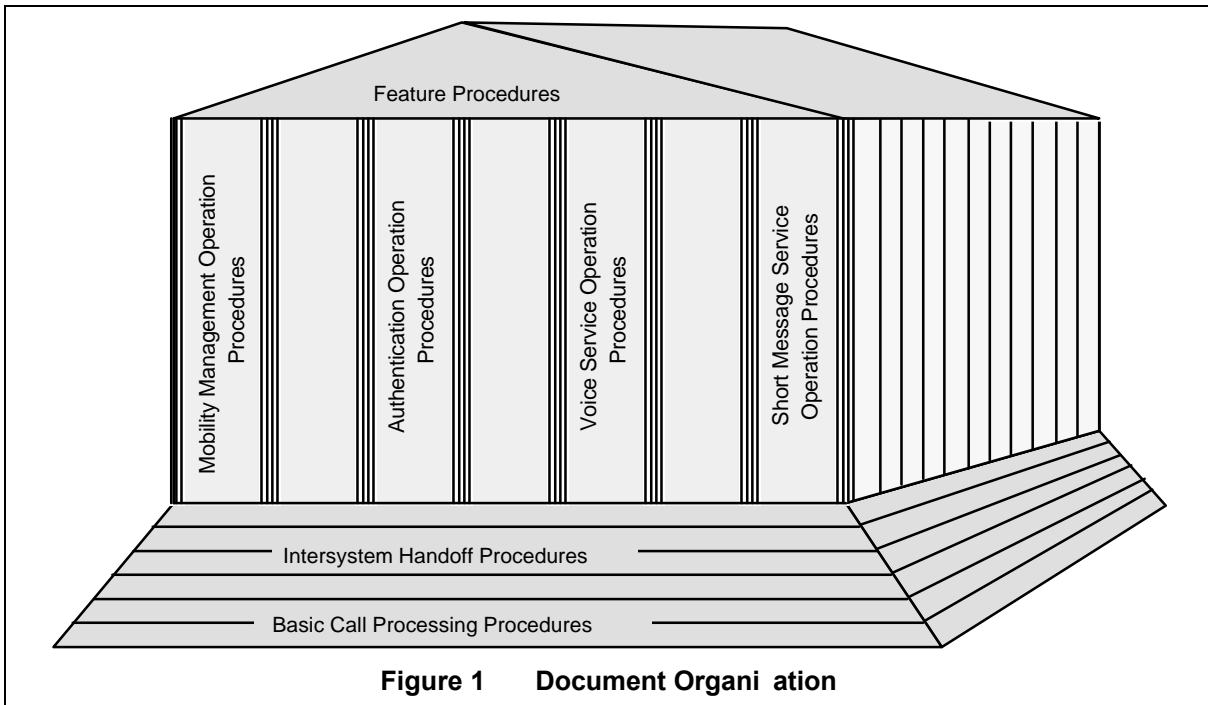

1.4 DOCUMENTATION CONVENTIONS

The start of a task or procedure is always the first line of text.

are statements enclosed in parenthesis.

alone on line identifies a point in a task where control may be connected.

<Processing steps> are expressed as simple statements, usually one per line.

E O E T E N E allows multiple branching with a single test in a task or procedure. The result of the expression is compared against the values in the value labels. If a match is found, the subordinate statements for that value are executed. When the last subordinate (indented) statement is executed, execution continues with the next statement after the ENDCASE statement at the same indentation level. Some license can be taken in specifying the value for the CASE labels. For example:

```

1      E the color of roses O :
2      Red
2-1    A1.
2-2    A2.
3      White
3-1    B1.
    
```

1
2
3
4
5
6
7
8
9
10
11
12
13
14
15
16
17
18
19
20
21
22
23
24
25
26
27
28
29
30
31
32
33
34
35
36
37
38
39
40
41
42
43
44
45
46
47
48
49
50
51
52
53
54
55
56
57
58
59
60

1
2
3
4
5
6
7
8
9
10
11
12
13
14
15
16
17
18
19
20
21
22
23
24
25
26
27
28
29
30
31
32
33
34
35
36
37
38
39
40
41
42
43
44
45
46
47
48
49
50
51
52
53
54
55
56
57
58
59
60

- 3-2 B2.
- 4 **DEFAULT:**
- 4-1 C1.
- 4-2 C2.
- 5 **EN E**
- 6 D1.

If roses are red, then A1, A2, and D1 are executed.

If roses are white, then B1, B2, and D1 are executed.

If roses are not red and not white, then C1, C2, and D1 are executed.

is used to reset the value of a message or state variable. If a binary value is not specified it may be assumed to use the value 0.

removes a received parameter to prevent it from being relayed.

E causes a self contained procedure to be executed.

E causes the current task to terminate its own operation. The task and all associated variables cease to exist.

O **EN O** is used to process multiple iterations of a particular sequence of subordinate processing steps.

OTO is used to transfer execution control to a specified label or task name.

E E E E E E
EN allows branching in a task or procedure. When the condition is true, the subordinate statements are executed, otherwise execution proceeds with the next statement at the same indentation as the current statement. When the last subordinate (indented) statement is executed, execution continues with the statement after the **ENDIF** statement at the same indentation level. **E E** allows for testing of multiple related conditions. **E E** allows for processing when the condition(s) are false. For example:

- 1 roses are red then:
- 1-1 A1.
- 1-2 A2.
- 2 **E E** roses are white then:
- 2-1 B1.
- 2-2 B2.
- 3 **E E:**
- 3-1 C1.
- 3-2 C2.

4 EN

5 D1.

If roses are red then A1, A2, and D1 are executed.

If roses are not red, but are white then B1, B2, and D1 are executed.

If roses are not red and not white, then C1, C2, and D1 are executed.

is used to include the particular parameter in an outgoing message.

O is used to indicate the communication of a command to a mobile station (MS) using local defined procedures and procedures specific to the air interface being used by the mobile station.

causes the named message to be transferred from the current task to the named destination task. The destination task must be on the same functional entity as the sender.

is used to indicate the execution of locally defined procedures that are currently not subject to standardization.

is used to include one or more received parameter(s) in the next outgoing message.

transfers execution control to the containing **T** statement.

is used to change the values of an incoming parameter for use with the next outgoing message.

causes the current procedure to exit and return control to the calling task or procedure.

causes the named message to be transferred from the current task to the named destination task. The destination may be on any functional entity. RETURN RESULTS, RETURN ERRORS, or REJECTS are understood to be sent to the functional entity sending a corresponding INVOKE.

is used to change the value of a message parameter or an internal state variable. If a binary value is not specified it may be assumed to use the value 1.

creates an instance of the named task which executes independently of the current task.

causes the named timer to be started from zero.

causes the named timer to be stopped.

T <state name or main event>... **EN** <event>... **EN** <event>...**EN** **T** identifies a state where a task waits for the occurrence of one or more possible events. Each **WHEN** identifies an event causing a state transition, such as, the arrival of a message or the expiry of a timer. All statements subordinate (indented) to the **WHEN** statement are executed. When the last subordinate (indented) statement is executed, execution continues

with the statement after the ENDWAIT statement at the same indentation level. For example:

```

1      T for message to arrive:
2      EN message arrives
3
4      2-1  A1.
5
6      2-2  A2.
7
8      3      EN error response arrives
9
10     3-1  B1.
11
12     3-2  B2.
13
14     4      EN timer expires:
15
16     4-1  C1.
17
18     4-2  C2.
19
20     5  EN      T
21
22     6  D1.

```

If the message arrives, then A1, A2, and D1 are executed.

If an error response arrives, then B1, B2, and D1 are executed.

If the timer expires, then C1, C2, and D1 are executed.

E **EN** **E** is used to process zero or more iterations of a particular sequence of subordinate processing steps while the condition remains true. All subordinate (indented) statements are executed while the condition is true. When the condition is false, execution begins with the statement following the ENDWHILE statement.

2 TECHNOLOGY AND CONCEPTS

See Annex E.

2.1 INTERSYSTEM HANDOFF PROCEDURES

This section provides the transaction procedures defined for the Intersystem Handoff. All messages and associated parameters are defined in Chapter 5; Timer values are specified in Section 7 of this Chapter.

Intersystem handoff uses dedicated voice and data facilities between the MSCs. Future versions may use other facilities. Handoffs are allowed to traverse from system to system with the total number of inter-MSC facilities in the sequence limited to the value of a parameter (MAXHANDOFF) which is programmed by the service providers. Path minimization is used to keep the number of MSCs involved in a call to a minimum. Handoff Back and Handoff-To-Third are actions taken to perform path minimization. The number of systems that can be involved in path minimization is limited to the value of a parameter (TANDEMDEPTH) which is programmed by the service providers.

This feature is manufacturer and system independent. This protocol does not preclude handoff between bands A and B within the same Cellular Geographic Serving Area (CGSA).

An off-hook MS is a unit that is currently involved in a call. Only off-hook MSs may handoff.

The procedures defined here are based on the assumption that intersystem handoff relies upon dedicated intersystem trunks. This is required since intersystem handoff is a tightly controlled activity of the cellular systems involved. Intersystem handoff cannot be considered any differently than an inter-cell handoff.

The handoff procedures specified in the following sections can be applied to consecutive inter-MSC handoffs for the same MS. A non-Anchor Serving MSC that has handed off a call becomes a Tandem MSC. The initial Serving MSC retains its role as an Anchor MSC.

2.2 SHORT MESSAGE SERVICE PROCEDURES

These procedures are written in such a way as to allow the invoking of other procedures, especially at the MSC and the MC. Air interface messages and procedures are defined in informative Annex D, so that all air interfaces can have common characteristics.

At the MSC, MS originated messages may be received over the air interface, from a Tandem MSC or from the Serving MSC as shown in the following figure. These MS originated messages may then be routed either toward the Anchor MSC or, at the Anchor MSC, toward the message's destination. Messages can either be initiated by an SME, an SME collocated with an HLR or MSC, an MS-based SME, or an MC.

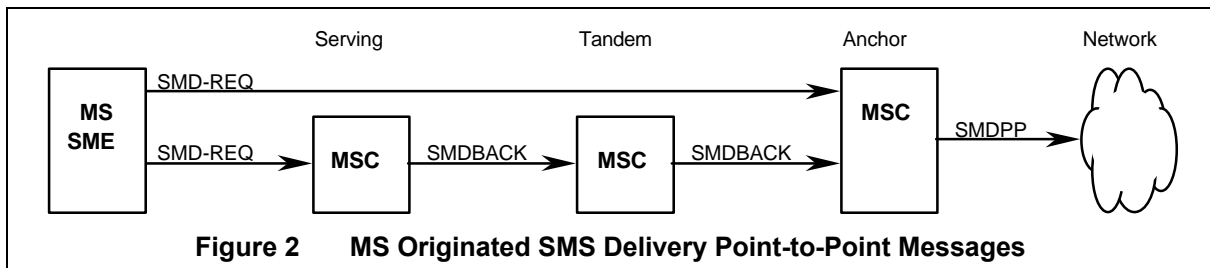

Figure 2 MS Originated SMS Delivery Point-to-Point Messages

1
2
3
4
5
6
7
8
9
10
11
12
13
14
15
16
17
18
19
20
21
22
23
24
25
26
27
28
29
30
31
32
33
34
35
36
37
38
39
40
41
42
43
44
45
46
47
48
49
50
51
52
53
54
55
56
57
58
59
60

The relationships of short message originations and the corresponding procedure is indicated in the following figure:

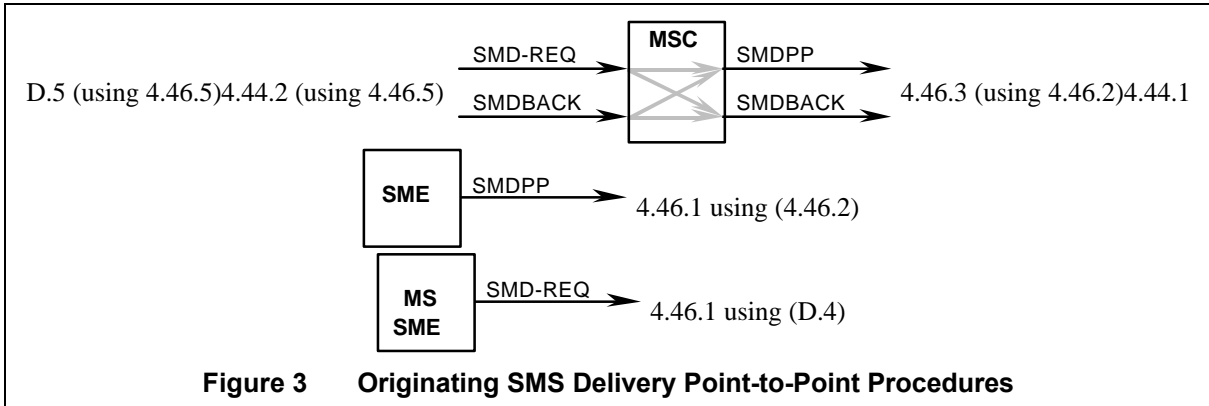

Figure 3 Originating SMS Delivery Point-to-Point Procedures

At the MSC MS terminating messages may be received from the network, from a Tandem MSC or from the Anchor MSC. These MS terminating messages may then be routed either toward the Serving MSC or, at the Serving MSC, toward the message's destination MS.

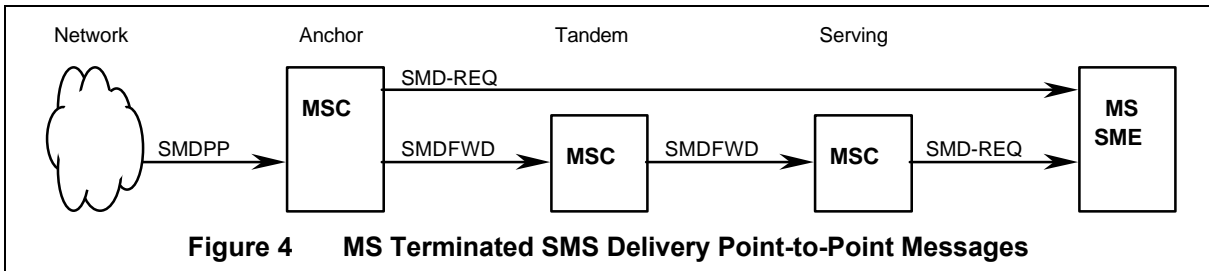

Figure 4 MS Terminated SMS Delivery Point-to-Point Messages

The relationships of short message terminations and the corresponding procedure is indicated in the following figure:

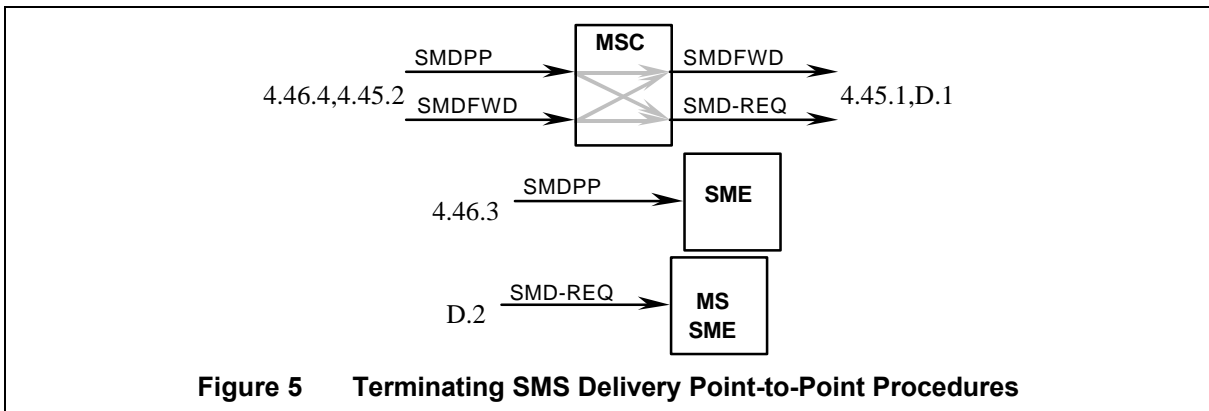

Figure 5 Terminating SMS Delivery Point-to-Point Procedures

Each of these tasks may be accepted, postponed or denied. An accepted request is one that has made it to its intended destination and that destination has responded. A postponed request is one that has been accepted by the network for later delivery to the intended destination. A denied request is one that is not accepted by the network or the intended destination. A cause is normally given with a denied request so that the sender can take appropriate action.

Messages to and from an SME may be processed by a network based Message Center (MC). The MC may provide Originating SMS Supplementary Services (OSSS) for messages originated by an SME by routing the messages to the SME's home MC (using indirect routing). Messages to an SME may be given Terminating SMS Supplementary Services (TSSS) by routing the message to the destination SME's home MC. It is possible for a message to have both originating and terminating supplementary services. These basic relationships are shown in the following figure.

There is only one home MC for each MS-based SME. This MC controls the delivery of messages to the MS-based SME as a TSSS. Notification for postponed delivery is only sent to this MC.

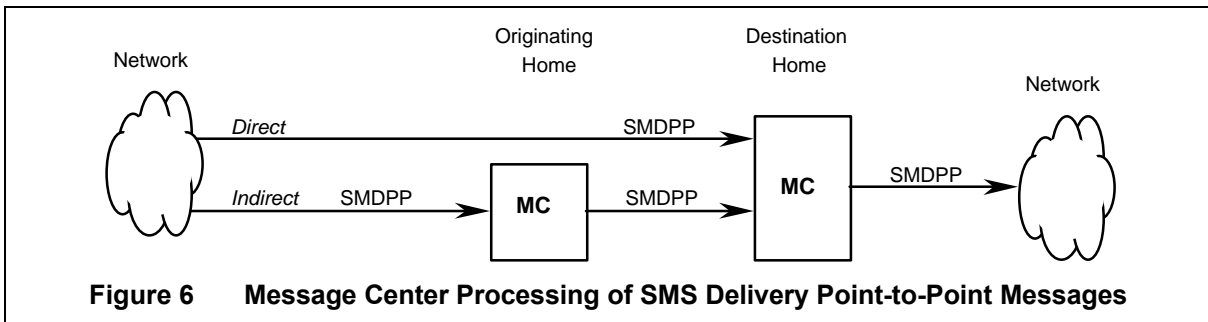

Figure 6 Message Center Processing of SMS Delivery Point-to-Point Messages

The relationships of Message Center messages and the corresponding procedure is indicated in the following figure:

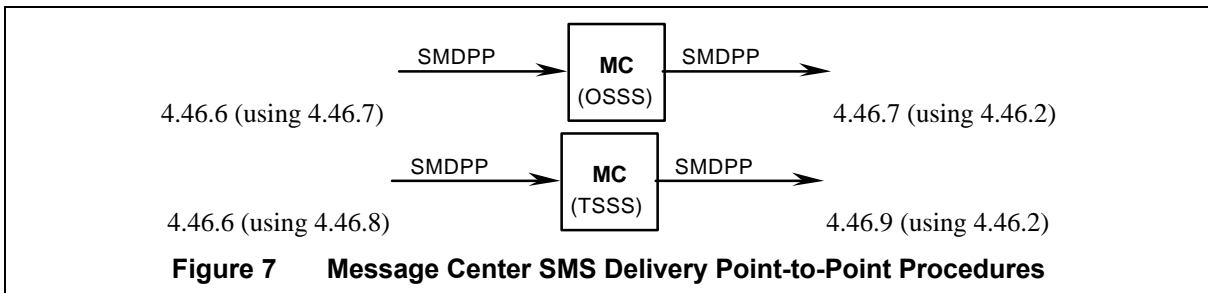

Figure 7 Message Center SMS Delivery Point-to-Point Procedures

These procedures are written to reduce the transmission of information. Destination and originating addresses may be carried by the underlying transport mechanism in some cases. However, the transport mechanism should not be used, if there is any possibility that it may change either of these addresses. The safest method is to always include the discrete address parameters.

1
2
3
4
5
6
7
8
9
10
11
12
13
14
15
16
17
18
19
20
21
22
23
24
25
26
27
28
29
30
31
32
33
34
35
36
37
38
39
40
41
42
43
44
45
46
47
48
49
50
51
52
53
54
55
56
57
58
59
60

3 BASIC CALL PROCESSING

3.1 REGISTRATION CALL TASKS

3.1.1 Autonomous or Power-On Registration

When the MSC becomes aware of the presence of an MS through registration, the Serving MSC should do the following:

- 1 IF the MS is not authenticated:
 - 1-1 IF the MS has authentication capabilities:
 - 1-1-1 Include the SystemAccessType parameter set to *Autonomous registration*.
 - 1-1-2 Execute the “MSC Initiating an Authentication Request” task (see 4.4.1).
 - 1-1-3 IF authentication fails:
 - 1-1-3-1 Execute “Local Recovery Procedures” task (see 3.5.1).
 - 1-1-3-2 Exit this task.
 - 1-1-4 ENDIF.
 - 1-2 ENDIF.
- 2 ENDIF.
- 3 IF the MS is not registered:
 - 3-1 Execute the “MSC Initiating MS Registration” task (see 4.38.1).
 - 3-2 IF the MS is not authorized:
 - 3-2-1 Execute “Local Recovery Procedures” task (see 3.5.1).
 - 3-3 ENDIF.
- 4 ENDIF.
- 5 Exit this task.

3.1.2 Power-Off Deregistration

When the MSC receives a power-off deregistration, the Serving MSC shall do the following:

- 1 IF the MS can authenticate according to MS’s AuthenticationCapability:
 - 1-1 Include the SystemAccessType parameter set to *Power down registration*.
 - 1-2 Execute the “MSC Initiating an Authentication Request” task (see 4.4.1).
 - 1-3 IF authentication fails:
 - 1-3-1 Execute “Local Recovery Procedures” task (see 3.5.1).
 - 1-3-2 Exit this task.
 - 1-4 ENDIF.
- 2 ENDIF.
- 3 Execute the “MSC Initiating an MS Inactive” task indicating a power down deregistration (see 4.30.1).

4 Exit this task.

3.1.3 Loading of Profile Parameters

Upon request, the HLR or VLR shall do the following:

- 1 Include the AuthenticationCapability parameter set appropriately.
- 2 Include the CallingFeaturesIndicator parameter set appropriately.
- 3 IF carrier selection digits are applicable:
 - 3-1 IF the Profile is supported for this transaction:
 - 3-1-1 Include the CarrierDigits parameter set to the carrier selection digits.
 - 3-2 ELSE:
 - 3-2-1 Include the Digits (Carrier) parameter set to the carrier selection digits.
 - 3-3 ENDIF.
 - 4 ENDIF.
- 5 IF default account code digits are applicable for calls by the subscriber:
 - 5-1 IF the Profile is supported for this transaction:
 - 5-1-1 Include the DMH_AccountCodeDigits parameter set to the appropriate default account code digits.
 - 5-2 ELSE:
 - 5-2-1 (Consider restricting originations.)
 - 5-3 ENDIF.
 - 6 ENDIF.
- 7 IF billing digits are applicable for calls by the subscriber:
 - 7-1 IF the Profile is supported for this transaction:
 - 7-1-1 Include the DMH_BillingDigits parameter set to the appropriate alternate billing digits.
 - 7-2 ELSE:
 - 7-2-1 (Consider restricting originations.)
 - 7-3 ENDIF.
 - 8 ELSEIF alternate billing digits are applicable for calls by the subscriber:
 - 8-1 IF the Profile is supported for this transaction:
 - 8-1-1 Include the DMH_AlternateBillingDigits parameter set to the appropriate alternate billing digits.
 - 8-2 ELSE:
 - 8-2-1 (Consider restricting originations.)
 - 8-3 ENDIF.
 - 9 ENDIF.
 - 10 IF the subscriber's current privileges are geographically restricted:
 - 10-1 IF the Profile is supported for this transaction:
 - 10-1-1 Include the GeographicAuthorization parameter set appropriately.
 - 10-2 ELSE:
 - 10-2-1 (Consider restricting originations.)

1 10-3 ENDIF.
2
3 11 ENDIF.
4 12 IF the subscriber is authorized for message waiting notification:
5 12-1 IF the Profile is supported for this transaction:
6 12-1-1 Include the MessageWaitingNotificationCount parameter set appropriately.
7 12-1-2 Include the MessageWaitingNotificationType parameter set appropriately.
8 12-2 ENDIF.
9 13 ENDIF.
10
11 14 IF the MS is to be identified with a mobile directory number (other than its MIN):
12 14-1 IF the Profile is supported for this transaction:
13 14-1-1 Include the MobileDirectoryNumber parameter set to the subscriber's current
14 directory number.
15 14-2 ELSE:
16 14-2-1 (Consider restricting originations and terminations or activating CNIR.)
17 14-3 ENDIF.
18 15 ENDIF.
19
20 16 Include the OriginationIndicator parameter set appropriately.
21 17 IF origination triggers are required:
22 17-1 IF the Profile is supported for this transaction:
23 17-1-1 Include the OriginationTriggers parameter set appropriately.
24 17-2 ELSE:
25 17-2-1 (Consider restricting originations.)
26 17-3 ENDIF.
27 18 ENDIF.
28
29 19 IF the subscriber is authorized for PACA:
30 19-1 IF the Profile is supported for this transaction:
31 19-1-1 Include the PACAIndicator parameter set appropriately.
32 19-2 ENDIF.
33 20 ENDIF.
34
35 21 IF the subscriber has a preferred language:
36 21-1 IF the Profile is supported for this transaction:
37 21-1-1 Include the PreferredLanguageIndicator parameter set appropriately.
38 21-2 ENDIF.
39 22 ENDIF.
40
41 23 IF restriction digits are required (as requested by the OriginationIndicator parameter):
42 23-1 IF the Profile is supported for this transaction:
43 23-1-1 Include the RestrictionDigits parameter set to the restriction digits.
44 23-2 ELSE:
45 23-2-1 Include the Digits (Destination) parameter set to the restriction digits.
46 23-3 ENDIF.
47 24 ENDIF.
48
49
50
51
52
53
54
55
56
57
58
59
60

- 25 IF routing digits are applicable for all calls by the subscriber: 1
- 25-1 IF the Profile is supported for this transaction: 2
- 25-1-1 Include the RestrictionDigits parameter set to the appropriate routing digits. 3
- 25-2 ELSE: 4
- 25-2-1 (Consider restricting originations.) 5
- 25-3 ENDIF. 6
- 26 ENDIF. 7
- 27 IF the MS is registered to an SMS capable system: 8
- 27-1 IF the Profile is supported for this transaction: 9
- 27-1-1 Include the SMS_OriginationRestrictions parameter set appropriately. 10
- 27-1-2 Include the SMS_TerminationRestrictions parameter set appropriately. 11
- 27-2 ELSE: 12
- 27-2-1 (Consider restricting originations.) 13
- 27-3 ENDIF. 14
- 28 ENDIF. 15
- 29 IF the current transaction supports local SPINI operation AND IF local SPINI 16
- operation is desirable: 17
- 29-1 Include the SPINITriggers parameter set with the appropriate triggers for local 18
- SPINI operation. 19
- 29-2 Include the SPINIPIN parameter set to the SPINI PIN. 20
- 30 ENDIF. 21
- 31 Include the TerminationRestrictionCode parameter set appropriately. 22
- 32 IF termination triggers are required: 23
- 32-1 IF the Profile is supported for this transaction: 24
- 32-1-1 Include the TerminationTriggers parameter set appropriately. 25
- 32-2 ELSE: 26
- 32-2-1 (Consider restricting terminations.) 27
- 32-3 ENDIF. 28
- 33 ENDIF. 29
- 34 Return to the calling task. 30

3.2 ORIGINATION CALL TASKS 31

3.2.1 Idle MS Origination 32

When the MS attempts to originate a call, the Serving MSC shall do the following: 33

- 1 IF an appropriate *idle* voice or traffic channel is available for the identified air interface 34
- control channel, the MSC may pre-seize the channel by: 35
- 1-1 Reserve the available voice or traffic channel. 36
- 1-2 Order the MS to acquire the reserved voice or traffic channel. 37
- 1-3 Verify the MS has properly tuned to this voice or traffic channel. 38

- 1 2 ENDIF.
- 2
- 3 IF the MS is not authenticated and authentication is active:
- 4 3-1 IF the MS has authentication capabilities and the MS's AuthenticationCapability
- 5 indicates that the MS shall be authenticated¹:
- 6 3-1-1 Include the SystemAccessType parameter set to *Call origination*.
- 7 3-1-2 Execute the "MSC Initiating an Authentication Request" task (see 4.4.1).
- 8 3-1-3 IF authentication fails:
- 9 3-1-3-1 Execute "Local Recovery Procedures" task (see 3.5.1).
- 10 3-1-3-2 Exit this task._
- 11 3-1-4 ENDIF.
- 12 3-2 ENDIF.
- 13
- 14 4 ENDIF.
- 15
- 16 5 IF the MS is not registered OR IF the location of the MS has changed since the last
- 17 registration:
- 18 5-1 Execute the "MSC Initiating MS Registration" task (see 4.38.1).
- 19
- 20 6 ELSEIF the MSC requires the MS's service profile (e.g., per call authorization required
- 21 or the service profile is not present):
- 22 6-1 Execute the "MSC Initiating Qualification Request" task (see 4.33.1).
- 23
- 24 7 ENDIF.
- 25
- 26 8 Execute "Initialize the OneTimeFeatureIndicator Parameter" task (see 3.2.8).
- 27
- 28 9 Execute "MSC Analyze MS Dialed Number" task (see 3.2.3).
- 29
- 30 10 IF the PointOfReturn is *ToneTermination*:
- 31 10-1 Execute "Apply Access Denial Treatment" task (see 3.4.5).
- 32 10-2 Exit this task.
- 33
- 34 11 ENDIF.
- 35
- 36 12 IF the MS is not authorized:
- 37 12-1 Execute "Apply Access Denial Treatment" task (see 3.4.5).
- 38 12-2 Exit this task._
- 39
- 40 13 ENDIF.
- 41
- 42 14 Execute the "MSC PACA Call Origination Invocation" task (see 5.17.2).
- 43
- 44 15 IF unsuccessful:
- 45 15-1 Execute "Apply Access Denial Treatment" task (see 3.4.5).
- 46
- 47 16 ELSE (seize the channel by):
- 48 16-1 Reserve the available voice or traffic channel.
- 49 16-2 Order the MS to acquire the reserved voice or traffic channel.
- 50 16-3 Verify the MS has properly tuned to this voice or traffic channel.
- 51 16-4 IF unsuccessful:
- 52 16-4-1 Execute "Apply Access Denial Treatment" task (see 3.4.5).
- 53
- 54

¹In addition the MSC shall initiate authentication procedures if the MS has authentication capabilities and there is no AuthenticationCapability information for the MS.

- 16-5 ENDIF. 1
- 17 ENDIF. 2
- 18 Execute the “MSC MWN Call Origination Invocation” task (see 5.13.7). 3
- 19 ENDIF. 4
- 20 IF the AnnouncementList parameter is received: 5
- 20-1 Execute the “Play All Announcements in the AnnouncementList” task (see 3.2.5). 6
- 21 ENDIF. 7
- 22 Execute the “MSC Routing Points Of Return” task (see 3.2.6). 8
- 23 Exit this task. 9

3.2.2 In Call MS Flash Attempt 10

When the MS attempts to signal during a call by pressing the SEND key, the Anchor MSC shall: 11

- 1 IF it is required to authenticate flash requests (e.g., signaling encryption is not supported): 12
- 1-1 Include the SystemAccessType parameter set to *Flash request*. 13
- 1-2 Execute the “MSC Initiating an Authentication Request” task (see 4.4.1). 14
- 1-3 IF authentication fails: 15
- 1-3-1 Execute “Local Recovery Procedures” task (see 3.5.1). 16
- 1-3-2 Exit this task. 17
- 1-4 ENDIF. 18
- 2 ENDIF. 19
- 3 IF *FlashPrivileges* are allowed by the OneTimeFeatureIndicator parameter: 20
- 3-1 IF CW has been invoked: 21
- 3-1-1 Put the current party on hold. 22
- 3-1-2 Connect the held party. 23
- 3-1-3 Optionally apply warning tone. 24
- 3-1-4 Exit this task. 25
- 3-2 ELSEIF a call is waiting for CW treatment: 26
- 3-2-1 Put the current party on hold. 27
- 3-2-2 Connect the waiting party. 28
- 3-2-3 Optionally apply warning tone. 29
- 3-2-4 Exit this task. 30
- 3-3 ELSEIF 3WC has been invoked: 31
- 3-3-1 Add the held party to the current connection. 32
- 3-3-2 Optionally apply warning tone. 33
- 3-3-3 Exit this task. 34
- 3-4 ELSEIF CT has been invoked: 35
- 3-4-1 Drop the current party. 36
- 3-4-2 Connect the held party. 37
- 3-4-3 Optionally apply warning tone. 38

- 1 3-4-4 Exit this task.
- 2
- 3 3-5 ELSEIF a party is on hold:
- 4 3-5-1 Connect the held party,
- 5 3-5-2 Optionally apply warning tone.
- 6
- 7 3-5-3 Exit this task.
- 8
- 9 3-6 ELSE:
- 10 3-6-1 Put the current call on hold.
- 11 3-6-2 IF there are no digits included with the flash request:
- 12 3-6-2-1 (Wait around for the subscriber to enter digits or execute internal
- 13 algorithms.)
- 14
- 15 3-6-3 ENDIF.
- 16 3-6-4 Execute “MSC Analyze MS Dialed Number” task to set the Point Of Return
- 17 (see 3.2.3).
- 18
- 19 3-7 ENDIF.
- 20 4 ENDIF.
- 21
- 22 5 Exit this task.
- 23

3.2.3 MSC Analyze MS Dialed Number

26 Upon demand the Anchor MSC shall do the following:

- 27
- 28 1 IF flash privileges are suspended (by the *Flash Privileges* in the OneTimeFeature-
- 29 Indicator parameter e.g., Call Transfer, Call Waiting, Three-Way Calling): ,
- 30 1-1 Include the TransactionCapability parameter with the number of multiple
- 31 terminations set to 0.
- 32
- 33 2 ELSEIF Call Transfer, Three-Way Calling, or similar feature is being invoked:
- 34 2-1 Include the TransactionCapability parameter with the number of multiple
- 35 terminations set to 1.
- 36
- 37 3 ELSE:
- 38 3-1 Include the TransactionCapability parameter with the number of multiple
- 39 terminations set appropriately.
- 40
- 41 4 ENDIF.
- 42 5 IF the MS dialed a locally allowed number (e.g., 9-1-1, *-9-1-1, N11, *N11):
- 43 5-1 IF the MS dialed number is only routed locally, for instance, for numbers used for
- 44 access to local emergency service providers:
- 45 5-1-1 Process the dialed number locally routing the call with the
- 46 PreferredLanguageIndicator to set the PointOfReturn.
- 47
- 48 5-2 ELSEIF the OriginationTriggers matches the *, # or the count of the dialed number
- 49 digits:
- 50 5-2-1 Execute the “MSC Initiating an Origination Request” task (see 4.31.1) to set
- 51 the PointOfReturn.
- 52
- 53 5-3 ELSE
- 54 5-3-1 Process the dialed Service Code locally routing the call with the
- 55 PreferredLanguageIndicator to set the PointOfReturn.
- 56
- 57 5-4 ENDIF
- 58
- 59
- 60

6	ELSEIF the OriginationTriggers <i>All</i> trigger is on:	1
6-1	Execute the “MSC Initiating an Origination Request” task (see 4.31.1) to set the PointOfReturn.	2
6-2	IF a Digits (Dialed) parameter is received:	3
6-2-1	IF the type of the Digits is <i>unknown</i> .	4
6-2-1-1	Process the dialed number locally to set the PointOfReturn.	5
6-2-2	ENDIF.	6
6-3	ENDIF.	7
7	ELSEIF the first digit was a star (*) digit:	8
7-1	IF the second digit was a star (*) digit:	9
7-1-1	IF the OriginationTriggers is set for double star codes:	10
7-1-1-1	Execute the “MSC Initiating an Origination Request” task (see 4.31.1) to set the PointOfReturn.	11
7-1-1-2	IF a Digits (Dialed) parameter is received:	12
7-1-1-2-1	IF the type of the Digits is <i>unknown</i> :	13
7-1-1-2-1-1	Process the dialed number as a local feature code to set the PointOfReturn.	14
7-1-1-2-2	ENDIF.	15
7-1-1-3	ENDIF.	16
7-1-2	ELSE:	17
7-1-2-1	Process the dialed number as a local feature code or local service code to set the PointOfReturn.	18
7-1-3	ENDIF.	19
7-2	ELSE (only a single star was dialed):	20
7-2-1	IF the OriginationTriggers is set for single star codes:	21
7-2-1-1	Execute the “MSC Initiating an Origination Request” task (see 4.31.1) to set the PointOfReturn.	22
7-2-2	ELSE:	23
7-2-2-1	Execute a “MSC Detecting Feature Request” (see 4.14.1) to set the PointOfReturn.	24
7-2-3	ENDIF.	25
7-2-4	IF a Digits (Dialed) parameter is received:	26
7-2-4-1	IF the type of the Digits is <i>unknown</i> .	27
7-2-4-1-1	Process the dialed number as a local feature code to set the PointOfReturn.	28
7-2-4-2	ENDIF.	29
7-2-5	ENDIF.	30
7-3	ENDIF.	31
8	ELSEIF the first digit was a pound (#) digit:	32
8-1	IF the second digit was a pound (#) digit:	33
8-1-1	IF the OriginationTriggers is set for double pound codes:	34
8-1-1-1	Execute the “MSC Initiating an Origination Request” task (see 4.31.1) to set the PointOfReturn.	35
		36
		37
		38
		39
		40
		41
		42
		43
		44
		45
		46
		47
		48
		49
		50
		51
		52
		53
		54
		55
		56
		57
		58
		59
		60

1 8-1-1-2 IF a Digits (Dialed) parameter is received:
2
3 8-1-1-2-1 IF the type of the Digits is *unknown*.
4 8-1-1-2-1-1 Process the dialed number as a local feature code to set the
5 PointOfReturn.
6 8-1-1-2-2 ENDIF.
7
8 8-1-1-3 ENDIF.
9 8-1-2 ELSE (the double pound trigger is not set):
10 8-1-2-1 Process the dialed number as a local feature code to set the
11 PointOfReturn.
12 8-1-3 ENDIF.
13
14 8-2 ELSE (only a single pound was dialed):
15 8-2-1 IF the OriginationTriggers is set for single pound codes:
16 8-2-1-1 Execute the “MSC Initiating an Origination Request” task (see 4.31.1) to
17 set the PointOfReturn.
18 8-2-1-2 IF a Digits (Dialed) parameter is received:
19 8-2-1-2-1 IF the type of the Digits is *unknown*.
20 8-2-1-2-1-1 Process the dialed number as a local feature code to set the
21 PointOfReturn.
22 8-2-1-2-2 ENDIF.
23 8-2-1-3 ENDIF.
24 8-2-2 ELSE (the pound trigger is not set):
25 8-2-2-1 Process the dialed number as a local feature code to set the
26 PointOfReturn.
27 8-2-3 ENDIF.
28 8-3 ENDIF.
29
30 9 ELSEIF the OriginationTriggers *Revertive Call* trigger is on AND the dialed number is
31 the MS’s mobile directory number (or MIN if the mobile directory number is not
32 available):
33 9-1 Execute the “MSC Initiating an Origination Request” task (see 4.31.1) to set the
34 PointOfReturn.
35 9-2 IF a Digits (Dialed) parameter is received:
36 9-2-1 IF the type of the Digits is *unknown*.
37 9-2-1-1 Process the dialed number locally to set the PointOfReturn.
38 9-2-2 ENDIF.
39 9-3 ENDIF.
40
41 10 ELSEIF any of OriginationTriggers *Count* triggers are on AND the number of digits
42 dialed equals the corresponding count trigger:
43 10-1 Execute the “MSC Initiating an Origination Request” task (see 4.31.1) to set the
44 PointOfReturn.
45 10-2 IF a Digits (Dialed) parameter is received:
46 10-2-1 IF the type of the Digits is *unknown*.
47 10-2-1-1 Process the dialed number locally to set the PointOfReturn.
48 10-2-2 ENDIF.
49
50
51
52
53
54
55
56
57
58
59
60

10-3	ENDIF.	1
11	ELSEIF any of OriginationTriggers <i>Local</i> , <i>Int l</i> , <i>W</i> , or <i>Unrec</i> , triggers are on AND the call type matches the corresponding trigger:	2
		3
		4
11-1	Execute the “MSC Initiating an Origination Request” task (see 4.31.1) to set the PointOfReturn.	5
		6
11-2	IF a Digits (Dialed) parameter is received:	7
		8
11-2-1	IF the type of the Digits is <i>unknown</i> .	9
		10
11-2-1-1	Process the dialed number locally to set the PointOfReturn.	11
		12
11-2-2	ENDIF.	13
11-3	ENDIF.	14
12	ELSEIF the any unknown OriginationTriggers are on (e.g., reserved bits set to 1 or extra octets with any bit set to 1):	15
		16
12-1	Execute the “MSC Initiating an Origination Request” task (see 4.31.1) to set the PointOfReturn.	17
		18
12-2	IF a Digits (Dialed) parameter is received:	19
		20
12-2-1	IF the type of the Digits is <i>unknown</i> .	21
		22
12-2-1-1	Process the dialed number locally to set the PointOfReturn.	23
		24
12-2-2	ENDIF.	25
12-3	ENDIF.	26
13	ELSEIF the call type matches an active trigger in the SPINITriggers parameter:	27
		28
13-1	Execute the “MSC SPINI Originating Call Invocation” task (see 5.21.3) to set the PointOfReturn.	29
		30
14	ELSEIF the any unknown SPINITriggers are on (e.g., reserved bits set to 1 or extra octets with any bit set to 1):	31
		32
14-1	Execute the “MSC SPINI Originating Call Invocation” task (see 5.21.3) to set the PointOfReturn.	33
		34
15	ELSEIF the MS is permitted to dial only a specific 10-digit number in the service profile (i.e., the MS has hot line activated):	35
		36
15-1	Set the dialed number to the 10-digit number in the service profile.	37
		38
15-2	Set the PointOfReturn to Directory Number.	39
		40
16	ELSEIF the MS is restricted from originating any call:	41
		42
16-1	Execute “Apply Access Denial Treatment” task (see 3.4.5).	43
		44
16-2	Exit this task._	45
		46
17	ELSEIF the subscriber shall be authorized on a per call basis OR IF authorization is due:	47
		48
17-1	Execute the “MSC Initiating a Qualification Request” task (see 4.33.1).	49
		50
17-2	IF the call is not authorized (AuthorizationDenied or OriginationIndicator is <i>Origination denied</i>):	51
		52
17-2-1	Execute “Apply Access Denial Treatment” task (see 3.4.5).	53
		54
17-2-2	Exit this task.	55
		56
17-3	ENDIF	57
18	ELSE:	58
		59
18-1	GOTO AuthorizedSubscriberOrigination.	60

19 ENDIF.

O

20 IF the call is on hold and PointOfReturn is *ToneTermination*:

20-1 Reconnect the current call.

21 ENDIF.

22 IF the AnnouncementList parameter is received:

22-1 Execute the “Play All Announcements in the AnnouncementList” task (see 3.2.5).

23 ENDIF.

24 IF the dialed or destination number is a potential mobile directory number:

24-1 Include TerminationAccessType parameter set to indicate *Mobile to*

MobileDirectoryNumber.

24-2 Execute the “MSC Initiating a Location Request” task (see 4.28.1) to set the PointOfReturn.

25 ELSE:

25-1 Set the PointOfReturn to *PSTNTermination*.

26 ENDIF.

27 IF the AnnouncementList parameter is received:

27-1 Execute the “Play All Announcements in the AnnouncementList” task (see 3.2.5).

28 ENDIF.

29 Execute the “MSC Routing Points of Return” task (see 3.2.6) to process the PointOfReturn.

30 Return to the calling task.

3.2.4 HLR Analyze MS Dialed Number

Upon request, the HLR shall do the following:

1 IF a Service Code (e.g., N11, *N11) was dialed:

1-1 Process the dialed Service Code into an appropriate destination including consideration the PreferredLanguageIndicator..

1-2 Set the PointOfReturn to *PSTNTermination*.

2 ELSEIF a Feature Code (e.g., *FC, *FC0, #FC, FC#) was dialed:

2-1 Process the dialed number as a feature code to set the PointOfReturn.

3 ELSEIF an MS dialed its own directory number:

3-1 CASE revertive treatment OF:

3-2 *VMR*:

3-2-1 Execute “HLR VMR Revertive Call Invocation” task (see 5.23.3).

3-3 *FA*:

3-3-1 Execute “HLR FA Revertive Call Invocation” task (see 5.12.4).

3-4 *MAH*:

3-4-1 Execute “HLR MAH Revertive Call Invocation” task (see 5.14.5).

3-5 *DEFAULT*:

- 3-5-1 Include the `AnnouncementCode` parameter within the `AnnouncementList` set to an accessed denied announcement. 1
- 3-5-2 Set the `PointOfReturn` to *ToneTermination*. 2
- 3-6 ENDCASE. 3
- 4 ELSE (a `TerminationAddress` was dialed): 4
- 4-1 Execute the “Termination Address Expansion” task (see 6.2.1). 5
- 5 ENDIF. 6
- 6 IF the destination address is acceptable: 7
- 6-1 (Allow the selected point of return to be processed.) 8
- 7 ELSE (destination address is not acceptable): 9
- 7-1 Remove the parameters for the selected point of return. 10
- 7-2 Include the `AnnouncementCode` parameter within the set to an accessed denied announcement. 11
- 7-3 Set the `PointOfReturn` to *ToneTermination*.. 12
- 8 ENDIF. 13
- 9 Exit this task. 14

3.2.5 Play All Announcements in the AnnouncementList

Upon request, the MSC shall do the following:

- 1 FOR all `AnnouncementCodes` in the `AnnouncementList` parameter: 25
- 1-1 IF the custom `AnnouncementCode` specified is supported: 26
- 1-1-1 IF the custom announcement is available in the subscriber’s preferred language: 27
- 1-1-1-1 Play the custom announcement in the subscriber’s preferred language. 28
- 1-1-2 ELSE: 29
- 1-1-2-1 Play the custom announcement in the system’s default language. 30
- 1-1-3 ENDIF. 31
- 1-2 ELSEIF the standard `AnnouncementCode` specified is supported: 32
- 1-2-1 IF the standard announcement is available in the subscriber’s preferred language: 33
- 1-2-1-1 Play the standard announcement in the subscriber’s preferred language. 34
- 1-2-2 ELSE: 35
- 1-2-2-1 Play the standard announcement in the system’s default language. 36
- 1-2-3 ENDIF. 37
- 1-3 ELSEIF the standard tone specified is supported: 38
- 1-3-1 Play the indicated tone to the caller. 39
- 1-4 ELSE: 40
- 1-4-1 (Do nothing.) 41
- 1-5 ENDIF. 42
- 2 ENDFOR. 43
- 3 IF the announcements are in the sequential class: 44

- 1 3-1 WAIT for the End of announcement:
 2
 3 3-2 WHEN the announcement(s) is over:
 4 3-2-1 Return to the calling task with a *listened* indication.
 5 3-3 WHEN the subscriber abandons:
 6 3-3-1 Return to the calling task with an *abandoned* indication.
 7 3-4 ENDWAIT.
 8
 9 4 ELSE (the announcements are in the concurrent or reserved class):
 10 4-1 Return to the calling task with a *no wait* indication .
 11
 12 5 ENDIF.
 13
 14

3.2.6 MSC Routing Points of Return

17 When an Originating MSC is requested to route a call or legs of a call, it shall do the
 18 following:

- 19
 20 1 (Subscriber parameters for this call are assumed from the stored profile.)
 21 2 Override call parameters for this call only with parameters received with the
 22 TerminationList parameter.
 23 3 FOR all terminations in the TerminationList parameter:
 24 3-1 Override call parameters for this call leg only with parameters received within the
 25 particular termination parameter.
 26 3-2 CASE termination OF:
 27 3-3 $LocalTermination$ (MSCID (Serving) is the same as this MSC's ID):
 28 3-3-1 IF the TerminationTreatment parameter is received:
 29 3-3-1-1 CASE TerminationTreatment value OF:
 30 3-3-1-2 $MSTermination$:
 31 3-3-1-2-1 Execute the "Authorize MS Termination Attempt" task (see 3.3.4).
 32 3-3-1-3 $VoiceMailStorage$:
 33 3-3-1-3-1 IF the DestinationDigits parameter is received:
 34 3-3-1-3-1-1 Select the voice mail system using the received
 35 DestinationDigits parameter.
 36 3-3-1-3-2 ELSE:
 37 3-3-1-3-2-1 Select the voice mail system using a default voice mail system
 38 identifier.
 39 3-3-1-3-3 ENDIF.
 40 3-3-1-3-4 IF the VoiceMailboxNumber parameter is received:
 41 3-3-1-3-4-1 Select the voice mail box within the voice mail system using the
 42 received VoiceMailboxNumber parameter.
 43 3-3-1-3-5 ELSE:
 44 3-3-1-3-5-1 Select the voice mail box within MIN.
 45 3-3-1-3-6 ENDIF.
 46 3-3-1-3-7 Connect the call to the selected voice mail box.
 47 3-3-1-4 $VoiceMailRetrieval$:
 48 3-3-1-4-1 IF the DestinationDigits parameter is received:
 49
 50
 51
 52
 53
 54
 55
 56
 57
 58
 59
 60

3-3-1-4-1-1	Select the voice mail system using the received DestinationDigits parameter.	1
		2
3-3-1-4-2	ELSE:	3
		4
3-3-1-4-2-1	Select the voice mail system using a default voice mail system identifier.	5
		6
3-3-1-4-3	ENDIF.	7
		8
3-3-1-4-4	IF the VoiceMailboxNumber parameter is received:	9
		10
3-3-1-4-4-1	Select the voice mail box within the voice mail system using the received VoiceMailboxNumber parameter.	11
		12
3-3-1-4-5	ELSE:	13
		14
3-3-1-4-5-1	Select the voice mail box within MIN.	15
		16
3-3-1-4-6	ENDIF.	17
		18
3-3-1-4-7	Connect the call to the selected voice mail box.	19
		20
3-3-1-4-8	IF the VoiceMailboxPIN parameter is received:	21
		22
3-3-1-4-8-1	Signal the PIN to the selected voice mail box.	23
		24
3-3-1-4-9	ENDIF.	25
		26
3-3-1-5	<i>DialogueTermination:</i>	27
		28
3-3-1-5-1	Select the dialogue by analyzing the received DestinationDigits parameter.	29
		30
3-3-1-5-2	Play announcements in the Preferred Language, collect digits, and perform other actions required by the locally defined dialog.	31
		32
3-3-1-5-3	Communicate as required with the HLR in a proprietary manner.	33
		34
3-3-1-6	<i>DEFAULT:</i>	35
		36
3-3-1-6-1	Execute "Local Recovery Procedures" task (see 3.5.1).	37
		38
3-3-1-7	ENDCASE.	39
		40
3-3-2	ENDIF.	41
		42
3-4	<i>IntersystemTermination:</i>	43
		44
3-4-1	Execute the "MSC Route the Call Leg Externally" task (see 3.3.8).	45
		46
3-5	<i>PSTNTermination:</i>	47
		48
3-5-1	Execute the "MSC Route the Call Leg Externally" task (see 3.3.8).	49
		50
3-6	<i>DEFAULT:</i>	51
		52
3-6-1	Execute "Local Recovery Procedures" task (see 3.5.1).	53
		54
3-7	ENDCASE.	55
		56
4	ENDFOR.	57
		58
5	Exit this task.	59
		60

3.2.7 Originating Call Sent

1	IF the TerminationTriggers parameter is received:	52
		53
1-1	IF the <i>NoAnswerTrigger</i> is set:	54
		55
1-2	Start the no answer timer.	56
		57
1-3	IF the termination is external to the MSC (<i>IntersystemTermination</i> or <i>PSTNTermination</i>).	58
		59
		60

1 1-3-1 IF the *BusyTrigger* or *RoutingFailureTrigger* is set:
2
3 1-3-1-1 Attach a monitor to the connection to detect routing failures reported in-
4 band.
5 1-3-2 ENDIF.
6
7 1-4 ENDIF.
8
9 2 ENDIF.
10
11 3 WAIT for the connection to be answered.
12
13 4 WHEN the call is answered:
14
15 4-1 Remove any applied tones or announcements.
16
17 4-2 Stop the no answer timer.
18
19 4-3 Cut through the connection.
20
21 4-4 IF other extended leg(s) apply to this connection:
22
23 4-4-1 IF the *ConferenceCallingIndicator* parameter is not received indicating at
24 least two conferees:
25
26 4-4-1-1 Drop the other extended leg(s).
27
28 4-4-1-2 Release the monitors for the other leg(s).
29
30 4-4-2 ELSE (CC is in effect):
31
32 4-4-2-1 Enter in the internal conference calling mode.
33
34 4-4-2-2 (Leave the other legs connected.)
35
36 4-4-3 ENDIF.
37
38 4-5 ENDIF.
39
40 5 WHEN the call is abandoned:
41
42 5-1 Remove any applied tones or announcements.
43
44 5-2 Release the monitor(s) for this call.
45
46 5-3 Release the leg(s) for this call.
47
48 5-4 Stop the no answer timer.
49
50 5-5 Exit this task.
51
52 6 WHEN a busy condition is detected:
53
54 6-1 Drop the extended leg.
55
56 6-2 Release the monitor for this leg.
57
58 6-3 Stop the no answer timer.
59
60 6-4 IF the *BusyTrigger* is set:
61
62 6-4-1 IF an *LegInformation* is received for this leg:
63
64 6-4-1-1 Include the *LegInformation* parameter.
65
66 6-4-2 ENDIF.
67
68 6-4-3 Execute the “MSC Initiating a Transfer-To-Number Request” task (see
69 4.49.1).
70
71 6-5 ELSE (*BusyTrigger* is not set):
72
73 6-5-1 (Ignore the occurrence.)
74
75 6-6 ENDIF.
76
77 7 WHEN a routing failure is detected:
78
79 7-1 Drop the extended leg.
80

- 7-2 Release the monitor for this leg. 1
- 7-3 Stop the no answer timer. 2
- 7-4 IF the *RoutingFailureTrigger* is set: 3
- 7-4-1 IF an *LegInformation* is received for this leg: 4
- 7-4-1-1 Include the *LegInformation* parameter. 5
- 7-4-2 ENDIF. 6
- 7-4-3 Execute the “MSC Initiating a Transfer-To-Number Request” task (see 4.49.1). 7
- 7-5 ELSE (*RoutingFailureTrigger* is not set): 8
- 7-5-1 (Ignore the occurrence.) 9
- 7-6 ENDIF. 10
- 8 WHEN the no answer timer expires: 11
- 8-1 IF an *LegInformation* parameter is received for this leg: 12
- 8-1-1 Include the *LegInformation* parameter. 13
- 8-2 ENDIF. 14
- 8-3 Execute the “MSC Initiating a Transfer-To-Number Request” task (see 4.49.1). 15
- 9 ENDWAIT. 16
- 10 Exit this task. 17

3.2.8 Initiali e the OneTimeFeatureIndicator Parameter

- 1 Clear all indicators in the *OneTimeFeatureIndicator* parameter. 18
- 2 IF *Call Waiting* is active in the *CallingFeaturesIndicator*: 19
- 2-1 Set the *Call Waiting for future incoming calls* field in the *OneTimeFeatureIndicator* parameter set to *Normal CW*. 20
- 3 ELSEIF *Priority Call Waiting* is active in the *CallingFeaturesIndicator*: 21
- 2-1 Set the *Priority Call Waiting for future incoming calls* field in the *OneTimeFeatureIndicator* parameter set to *Priority CW*. 22
- 3 ELSE: 23
- 3-1 Set the *Call Waiting for future incoming calls* field in the *OneTimeFeatureIndicator* parameter set to *No CW*. 24
- 4 ENDIF. 25
- 5 IF *MessageWaitingNotification* for *Pip Tones* is active in the *MessageWaitingNotificationType* parameter: 26
- 5-1 Set the *Message Waiting Notification* indicator in the *OneTimeFeatureIndicator* parameter. 27
- 6 ENDIF. 28
- 7 IF *CallingNumberIdentificationRestriction* is active in the *CallingFeaturesIndicator*: 29
- 7-1 Set the *Calling Number Identification Restriction* indicator in the *OneTimeFeatureIndicator* parameter. 30
- 8 ENDIF. 31
- 9 IF *Permanent Activation (PA)* is active in the *PACAIndicator* parameter: 32

- 1
2
3
4
5
6
7
8
9
- 9-1 Set the *Priority Access and Channel Assignment* indicator in the *OneTimeFeatureIndicator* parameter.
 - 10 ENDIF.
 - 11 Return to the calling task.

3.2.9 MSC ActionCode Processing

- 10
11
12
13
14
15
16
17
18
19
20
21
22
23
24
25
26
27
28
29
30
31
32
33
34
35
36
37
38
39
40
41
42
43
44
45
46
47
48
49
50
51
52
53
54
55
56
57
58
59
60
- 1 CASE ActionCode parameter value OF:
 - 2 *Disconnect call:*
 - 2-1 Disconnect the call by executing the “Commanded Disconnect” task (see 3.4.3).
 - 3 *Disconnect call leg::*
 - 3-1 IF a *LegInformation* is received AND IF the received *LegInformation* matches an outstanding leg for this call:
 - 3-1-1 Disconnect the leg.
 - 3-2 ELSE:
 - 3-2-1 Disconnect the call by executing the “Commanded Disconnect” task (see 3.4.3).
 - 3-3 ENDIF.
 - 4 *Conference calling drop last party:*
 - 4-1 IF the call is in the internal Conference Calling processing mode.
 - 4-1-1 IF there are at least two parties to the conference call.
 - 4-1-1-1 Disconnect the conference party that has been connected for the shortest period of time.
 - 4-1-2 ELSE:
 - 4-1-2-1 Disconnect the call by executing the “Commanded Disconnect” task (see 3.4.3).
 - 4-1-3 ENDIF.
 - 4-2 ENDIF.
 - 5 *Bridge leg(s) to conference call:*
 - 5-1 Extend the call leg with the routing instructions.
 - 5-2 IF Conference Calling is invoked (i.e., a *ConferenceCallingIndicator* parameter is received indicating more than 2 parties):
 - 5-2-1 Add the leg to a conference circuit.
 - 5-3 ELSEIF call is only a two-way call AND IF a three-way calling circuit is available:
 - 5-3-1 Bridge the leg to a three-way calling circuit.
 - 5-4 ELSEIF the call is only a one-way call:
 - 5-4-1 Connect the call leg to the calling subscriber.
 - 5-5 ELSE (an error condition has occurred):
 - 5-5-1 Drop the newly extended leg.
 - 5-5-2 Play an appropriate announcement or tone.
 - 5-6 ENDIF.
 - 6 *Drop leg on busy or routing failure:*
 - 6-1 Extend the call leg with the routing instructions.

- 6-2 Add the leg to a simultaneous alerting bridge and drop the leg automatically should the leg not be routable or should the leg reach a busy party or should another leg be answered or should the call be abandoned.
- 7 *DEFAULT:*
- 7-1 (ignore the action code.)
- 8 ENDCASE.
- 9 Return to the calling task.

3.3 TERMINATING CALL TASKS

3.3.1 Incoming Call Attempt

When an MSC receives a call, it shall do the following:

- 1 IF call is an RFC port:
 - 1-1 Include `TerminationAccessType` parameter set to indicate a *RemoteFeatureControlPort*.
 - 1-2 Execute the “MSC Initiating a Location Request” task (see 4.28.1) to set the `PointOfReturn`.
- 2 ELSEIF call is to a potential TLDN:
 - 2-1 IF the call is to an assigned TLDN:
 - 2-1-1 GOTO “TLDN Call Arrival” in the “Wait for TLDN Call” task (see 3.3.2).
 - 2-2 ELSE (including the calls to an unassigned TLDN):
 - 2-2-1 Execute “Apply Access Denial Treatment” task (see 3.4.5).
 - 2-2-2 Exit this task.
 - 2-3 ENDIF.
 - 3 ELSEIF call is to a roamer port:
 - 3-1 Include `TerminationAccessType` parameter set to indicate
 - 3-2 Execute the “MSC Initiating a Location Request ” task (see 4.28.1) to set the `PointOfReturn`.
 - 3-3 IF the `AnnouncementList` parameter is received:
 - 3-3-1 Execute the “Play All Announcements in the `AnnouncementList`” task (see 3.2.5).
 - 3-4 ENDIF.
 - 4 ELSE call is to a potential mobile directory number:
 - 4-1 Include `TerminationAccessType` parameter set to indicate *Land to MobileDirectoryNumber*.
 - 4-2 Execute the “MSC Initiating a Location Request ” task (see 4.28.1) to set the `PointOfReturn`.
 - 5 ENDIF.
 - 6 Exit this task.

3.3.2 Wait for TLDN Call

Upon request, an MSC shall do the following:

- 1 Start the TLDN Association Timer (TLDNAT).
- 2 WAIT for arrival of call to the TLDN:
- 3 WHEN a call arrives for the TLDN:
 - T N**
 - 3-1 Stop the timer (TLDNAT).
 - 3-2 Free the TLDN for other use.
 - 3-3 Retain information such as the Originating MSC ID for possible call redirection use, but remove the record associated with that TLDN.
 - 3-4 CASE TerminationTreatment OF:
 - 3-5 *MSTermination*:
 - 3-5-1 IF the MS has activated Call Forwarding Unconditional since the RoutingRequest was received (i.e., a QualificationDirective was received after the RoutingRequest):
 - 3-5-1-1 Include the RedirectionReason parameter set to *Unconditional*.
 - 3-5-1-2 IF the leg was established with an LegInformation parameter:
 - 3-5-1-2-1 Include the LegInformation parameter set to the same value as received.
 - 3-5-1-3 ENDIF.
 - 3-5-1-4 IF the Originating MSC is provisioned for call redirection:
 - 3-5-1-4-1 Execute the “MSC Initiating a Redirection Request” task (see 4.36.1).
 - 3-5-1-5 ELSE:
 - 3-5-1-5-1 Execute the “MSC Initiating a Transfer-To-Number Request” task (see 4.49.1).
 - 3-5-1-6 ENDIF.
 - 3-5-1-7 Exit this task.
 - 3-5-2 ELSE:
 - 3-5-2-1 Execute the “Authorize MS Termination Attempt” task (see 3.3.4).
 - 3-5-3 ENDIF.
 - 3-6 *VoiceMailStorage*:
 - 3-6-1 Select the voice mail system using the stored voice mail system identifier.
 - 3-6-2 Select the voice mail box within the voice mail system using the stored voice mail box number.
 - 3-6-3 Connect the call to the selected voice mail box.
 - 3-7 *VoiceMailRetrieval*:
 - 3-7-1 Select the voice mail system using the stored voice mail system identifier.
 - 3-7-2 Select the voice mail box within the voice mail system using the stored voice mail box number.
 - 3-7-3 Connect the call to the selected voice mail box.
 - 3-7-4 IF the voice mail PIN is stored:

3-7-4-1	Signal the PIN to the selected voice mail box.	1
3-7-5	ENDIF.	2
3-8	<i>DialogTermination:</i>	3
3-8-1	Select the <i>dialog</i> using the digits in the received DestinationDigits parameter.	4
3-8-2	Play announcements in the Preferred Language, collect digits, and perform other actions required by the locally defined dialog.	5
3-8-3	Communicate as required with the HLR in a proprietary manner.	6
3-9	<i>DEFAULT:</i>	9
3-9-1	Execute “Local Recovery Procedures” task (see 3.5.1).	10
3-10	ENDCASE.	11
4	WHEN the timer (TLDNAT) expires:	12
4-1	Free the TLDN for other use.	13
4-2	Remove the record associated with that TLDN._	14
5	ENDWAIT.	15
6	Exit this task.	16

3.3.3 Page an MS Procedure

Upon request, the Serving MSC shall do the following to page a mobile station (MS):

1	IF the LocationAreaID is known for the MS:	25
1-1	Page the MS locally within the paging area defined for the LocationAreaID .	26
2	ELSE:	27
2-1	Page the MS locally within the entire service area.	28
3	ENDIF.	29
4	IF local procedures indicate that intersystem paging should be initiated to the neighboring MSCs, then before, after or simultaneously with local paging:	30
4-1	IF the TLDN call has arrived:	31
4-1-1	Spawn the “MSC Initiating an InterSystemPage2” as an independent task (see 4.26.1).	32
4-2	ELSE:	33
4-2-1	Spawn the “MSC Initiating an InterSystemPage” as an independent task (see 4.25.1).	34
4-3	ENDIF.	35
5	ENDIF.	36
6	Start a page response timer:	37
7	WAIT for a paging response:	38
8	WHEN a local page response is received:	39
8-1	Stop the page response timer.	40
8-2	Return with a local successful indication.	41
9	WHEN a intersystem page response notification is received:	42
9-1	Stop the page response timer.	43
9-2	IF an AccessDeniedReason parameter is received:	44

- 1 9-2-1 IF the local page response is still expected:
 2
 3 9-2-1-1 Remain in this state.
 4 9-2-2 ELSE:
 5 9-2-2-1 Relay this parameter.
 6 9-2-2-2 Return with an unsuccessful indication.
 7 9-2-3 ENDF.
 8
 9 9-3 ELSE:
 10
 11 9-3-1 Relay the received Digits, the Border MSC's MSCID information and
 12 PC_SSN parameters.
 13 9-3-2 Return with a bordering system successful indication.
 14 9-4 ENDF.
 15
 16 10 WHEN an unsolicited page response notification is received:
 17 10-1 Stop the page response timer.
 18 10-2 Stop the paging process for the indicated MS.
 19 10-3 Relay the Digits, the Border MSC's MSCID information and the PC_SSN
 20 parameters received in the UnsolicitedPageResponse INVOKE.
 21 10-4 Return with a bordering system successful indication.
 22
 23 11 WHEN the page response timer expires:
 24 11-1 Include the AccessDeniedReason parameter set to *NoPageResponse*.
 25 11-2 Return with an unsuccessful indication.
 26 12 ENDWAIT.
 27 13 Discontinue the local paging operation.
 28 14 Return with an unsuccessful indication.
 29
 30
 31
 32
 33

3.3.4 Authorize MS Termination Attempt

36 When an MSC is requested to terminate call to a mobile station (MS), it shall do the
 37 following:
 38

- 39 1 IF the MS is not in radio contact:
 40 1-1 Execute the "Page an MS Procedure" (see 3.3.3).
 41 2 ENDF.
 42 3 IF the MS is not authenticated:
 43 3-1 IF the MS has authentication capabilities:
 44 3-1-1 Include SystemAccessType parameter set to *Page response*.
 45 3-1-2 Execute the "MSC Initiating an Authentication Request" task (see 4.4.1).
 46 3-1-3 IF authentication fails:
 47 3-1-3-1 Execute "Local Recovery Procedures" task (see 3.5.1).
 48 3-1-3-2 Exit this task.
 49 3-1-4 ENDF.
 50 3-2 ENDF.
 51 4 ENDF.
 52 5 IF the MS is not registered:
 53
 54
 55
 56
 57
 58
 59
 60

- 5-1 Execute the “MSC Initiating MS Registration” task (see 4.38.1).
- 6 ELSEIF the MSC requires the MS’s service profile:
- 6-1 Execute the “MSC Initiating a Qualification Request” task (see 4.33.1).
- 7 ENDIF.
- 8 IF the MS is authorized:
- 8-1 GOTO the “MS Termination Alerting” task (see 3.3.5).
- 9 ELSE (the MS is not authorized):
- 9-1 Execute “Apply Access Denial Treatment” task (see 3.4.5).
- 10 ENDIF.
- 11 Exit this task.

1
2
3
4
5
6
7
8
9
10
11
12
13
14
15
16
17
18
19
20
21
22
23
24
25
26
27
28
29
30
31
32
33
34
35
36
37
38
39
40
41
42
43
44
45
46
47
48
49
50
51
52
53
54
55
56
57
58
59
60

3.3.5 MS Termination Alerting

Upon request, the MSC shall perform the following:

- 1 IF the indicated MS is *idle*:
- 1-1 IF a channel has not been allocated for the MS (i.e., the MS has not been paged):
- 1-1-1 IF an appropriate *idle* voice or traffic channel is available for the identified air interface control channel:
- 1-1-1-1 Reserve the available voice or traffic channel.
- 1-1-1-2 Execute the “Page an MS Procedure” (see 3.3.3).
- 1-1-1-3 IF the paging was locally successful:
- 1-1-1-3-1 GOTO Await Answer.
- 1-1-1-4 ELSEIF the paging was successful on another system:
- 1-1-1-4-1 Execute the “MSC Initiation of an Intersystem Setup” task (see 4.27.1).
- 1-1-1-4-2 GOTO Await Answer.
- 1-1-1-5 ELSE (the paging was unsuccessful):
- 1-1-1-5-1 IF the MS has activated Call Forwarding-No Answer in the CallingFeaturesIndicator or has the *No Page Response TerminatingTrigger* active:
- 1-1-1-5-1-1 Include the RedirectionReason parameter set to *No Page Response*.
- 1-1-1-5-1-2 IF this call has requested the *None Reachable* termination trigger AND IF this is the last leg AND IF a GroupInformation parameter was received:
- 1-1-1-5-1-2-1 Include the GroupInformation parameter.
- 1-1-1-5-1-3 ELSEIF the LegInformation parameter was received:
- 1-1-1-5-1-3-1 Include the LegInformation parameter.
- 1-1-1-5-1-4 ENDIF.
- 1-1-1-5-1-5 IF the MSC is the Originating MSC:
- 1-1-1-5-1-5-1 Execute the “MSC Initiating a Transfer-To-Number Request” task (see 4.49.1).
- 1-1-1-5-1-6 ELSEIF the Originating MSC is provisioned for call redirection:

- 1-1-1-5-1-6-1 Execute the “MSC Initiating a Redirection Request” task (see 4.36.1).
- 1-1-1-5-1-7 ELSE:
- 1-1-1-5-1-7-1 Execute the “MSC Initiating a Transfer-To-Number Request” task (see 4.49.1).
- 1-1-1-5-1-8 ENDIF.
- 1-1-1-5-2 ELSE:
- 1-1-1-5-2-1 Execute “Apply Access Denial Treatment” (see 3.4.5).
- 1-1-1-5-2-2 Exit this task.
- 1-1-1-5-3 ENDIF.
- 1-1-1-6 ENDIF.
- 1-1-2 ENDIF.
- 1-2 ENDIF.
- 1-3 IF the `RoutingDigits` parameter is received:
- 1-3-1 Analyze the routing digits to select an internal trunk group (such as, a service monitor, scrambling device).
- 1-3-2 Execute the “MSC CNIP Terminating Call Invocation” task (see 5.8.4).
- 1-4 ENDIF.
- 1-5 IF the `MobileDirectoryNumber` parameter is received:
- 1-5-1 Include the `MobileDirectoryNumber` parameter as the Called Number in the MS alerting command.
- 1-6 ELSE:
- 1-6-1 Include the `MobileIdentificationNumber` parameter as the Called Number in the MS alerting command.
- 1-7 ENDIF.
- 1-8 IF the `AlertCode` parameter received:
- 1-8-1 Include the `AlertCode` parameter in the MS alerting command to control the pitch and cadence of the alerting.
- 1-9 ELSE:
- 1-9-1 Include the system default `AlertCode` parameter in the MS alerting command to control the pitch and cadence of the alerting.
- 1-10 ENDIF.
- 1-11 Order the MS to alert.
(get here for normal and CW alerting, alerting has been applied, no timers have been started)
- 1-12 IF the `TerminationTriggers` is received:
- 1-12-1 Store the `TerminationTriggers` parameter for this leg.
- 1-12-2 IF the `NoAnswer` trigger is requested in the `TerminationTriggers` parameter OR IF the MS has Call Forwarding—No Answer activated in the `CallingFeaturesIndicator` parameter:
- 1-12-2-1 IF the `NoAnswerTime` parameter is received:
- 1-12-2-1-1 Start a no answer timer with the value in the received `NoAnswerTime` parameter.
- 1-12-2-2 ELSE:

1-12-2-2-1	Start a no answer timer	with a system default value.	1
1-12-2-3	ENDIF.		2
1-12-3	ENDIF.		3
1-13	ENDIF.		4
1-14	IF the LegInformation	parameter is received:	5
1-14-1	Store the LegInformation	to control subsequent redirections.	6
1-15	ENDIF.		7
1-16	Start the alerting timer.		8
1-17	Apply ring back tone to the waiting call.		9
1-18	WAIT for the MS to answer:		10
1-19	WHEN the MS answers:		11
1-19-1	Remove the ring back tone.		12
1-19-2	Connect the MS to the waiting call.		13
1-19-3	IF the OneTimeFeatureIndicator parameter was received and the Call Waiting for future incoming calls	field is not set to <i>Ignore</i> :	14
1-19-3-1	Set the Call Waiting for the existing call	field in the OneTimeFeatureIndicator parameter equal to the OneTimeFeatureIndicator Call Waiting For Future Incoming Calls field.	15
1-19-4	ELSE (the OneTimeFeatureIndicator parameter was not received or the Call Waiting for Future Incoming Calls	field is set to <i>Ignore</i>):	16
1-19-4-1	IF Call Waiting	is <i>active</i> in the CallingFeaturesIndicator:	17
1-19-4-1-1	Set the Call Waiting for future incoming calls	field in the OneTimeFeatureIndicator parameter set to <i>Normal CW</i> .	18
1-19-4-2	ELSEIF Priority Call Waiting	is <i>active</i> in the CallingFeaturesIndicator:	19
1-19-4-2-1	Set the Priority Call Waiting for future incoming calls	field in the OneTimeFeatureIndicator parameter set to <i>Priority CW</i> .	20
1-19-4-3	ELSE:		21
1-19-4-3-1	Set the <i>Call Waiting for future incoming calls</i>	field in the OneTimeFeatureIndicator parameter set to <i>No CW</i> .	22
1-19-4-4	ENDIF.		23
1-19-5	ENDIF:		24
1-20	WHEN the alerting timer	expires:	25
1-20-1	Remove the ring back tone.		26
1-20-2	Connect the calling party to an announcement or tone to indicate that the called party is not answering.		27
1-21	WHEN the answer timer	expires:	28
1-21-1	Include the RedirectionReason parameter set to <i>No Answer</i> .		29
1-21-2	IF this call has requested the <i>None Reachable (NR)</i> termination trigger AND IF this is the last leg AND IF a GroupInformation	parameter was received:	30
1-21-2-1	Include the GroupInformation	parameter.	31
1-21-3	ELSEIF the LegInformation	parameter was received:	32
1-21-3-1	Include the LegInformation	parameter.	33
1-21-4	ENDIF.		34
			35
			36
			37
			38
			39
			40
			41
			42
			43
			44
			45
			46
			47
			48
			49
			50
			51
			52
			53
			54
			55
			56
			57
			58
			59
			60

1 1-21-5 IF the MSC is the Originating MSC:
2
3 1-21-5-1 Execute the “MSC Initiating a Transfer-To-Number Request” task (see
4 4.49.1).
5 1-21-6 ELSEIF the Originating MSC is provisioned for call redirection:
6
7 1-21-6-1 Execute the “MSC Initiating a Redirection Request” task (see 4.36.1).
8
9 1-21-7 ELSE:
10
11 1-21-7-1 Execute the “MSC Initiating a Transfer-To-Number Request ” task (see
12 4.49.1).
13 1-21-8 ENDIF.
14 1-22 ENDWAIT.
15 2 ELSE (the indicated MS is busy):
16
17 2-1 IF Call Waiting is invoked (there is another call pending¹) OR IF the MS is
18 otherwise unable to accept a call (e.g., the MS has invoked Priority Access and
19 Channel Assignment, Call Transfer, Conference Calling, Three-Way or the MS
20 is not in a state where it can apply Call Waiting.):
21
22 2-1-1 GOTO Busy MS Detected.
23 2-2 ELSE (the MS may accept CW).
24
25 2-2-1 IF the RoutingDigits parameter is received:
26
27 2-2-1-1 Analyze the Routing digits to select an internal trunk group (such as, a
28 service monitor, scrambling device).
29 2-2-2 ENDIF.
30 2-2-3 IF the MobileDirectoryNumber parameter is received:
31 2-2-3-1 Include the MobileDirectoryNumber parameter as the Called Number in
32 the MS alerting command.
33 2-2-4 ELSE:
34 2-2-4-1 Include the MobileIdentificationNumber parameter as the Called Number
35 in the MS alerting command.
36 2-2-5 ENDIF.
37 2-2-6 Execute the “MSC CW Terminating Call Invocation” task (see 5.7.4).
38 2-2-7 IF Call Waiting is *accepted*:
39 2-2-7-1 GOTO Await Answer.
40 2-2-8 ELSE (Call Waiting was not accepted, the MS is busy):
41
42
43
44
45 2-2-8-1 IF the MS has activated Call Forwarding^ÑBusy or has the Busy
46 TerminationTriggers set to *Launch a RedirectionRequest* or
47 *TransferToNumberRequest*:
48 2-2-8-1-1 Include the RedirectionReason parameter set to *Busy*.
49
50
51
52

53 ¹MS busy or call pending can be defined as either a) actual calls in the MSC or b) a
54 combination of actual calls in the MSC or TLDNs assigned. Choice b) uses less of the call
55 redirection procedures and thereby routes calls faster. Choice a) handles abandoned calls
56 more properly.
57
58
59
60

2-2-8-1-2	IF this call has requested the <i>None Reachable</i> termination trigger AND IF this is the last leg AND IF a GroupInformation parameter was received:	1
		2
		3
		4
2-2-8-1-2-1	Include the GroupInformation parameter.	5
2-2-8-1-3	ELSEIF the LegInformation parameter was received:	6
2-2-8-1-3-1	Include the LegInformation parameter.	7
		8
2-2-8-1-4	ENDIF.	9
2-2-8-1-5	IF the call arrived via Call Delivery:	10
		11
2-2-8-1-5-1	IF the Originating MSC is provisioned for call redirection:	12
2-2-8-1-5-1-1	Execute the “MSC Initiating a Redirection Request” task (see 4.36.1).	13
		14
2-2-8-1-5-2	ELSE:	15
		16
2-2-8-1-5-2-1	Execute the “MSC Initiating a Transfer-To-Number Request” task (see 4.49.1).	17
		18
2-2-8-1-5-3	ENDIF.	19
2-2-8-1-6	ELSE (call did not arrive via Call Delivery):	20
		21
2-2-8-1-6-1	Execute the “MSC Initiating a Transfer-To-Number Request” task (see 4.49.1).	22
		23
2-2-8-1-7	ENDIF.	24
		25
2-2-8-2	ELSE (busy triggers do not apply):	26
		27
2-2-8-2-1	Apply busy treatment to the waiting call (e.g., apply busy tone).	28
		29
2-2-8-3	ENDIF.	30
		31
2-2-9	ENDIF.	32
		33
2-3	ENDIF.	34
		35
3	ENDIF.	36
		37
4	Return to the calling task.	38
		39
		40
		41
		42
		43
		44
		45
		46
		47
		48
		49
		50
		51
		52
		53
		54
		55
		56
		57
		58
		59
		60

3.3.6 MSC Special MS Alerting

Upon request, the MSC shall do the following:

- 1 IF an AlertCode parameter is received AND IF the MS can properly handle the AlertCode AND IF the MS is idle:
 - 1-1 Page the MS locally.
 - 1-2 Start a page response timer:
 - 1-3 WAIT for the MS to respond.
 - 1-4 WHEN the MS responds:
 - 1-4-1 Stop the page response timer.
 - 1-4-2 Order the MS to begin alerting.
 - 1-4-3 Start an alerting timer.
 - 1-4-4 IF a wait for answer was requested:
 - 1-4-4-1 WAIT for the MS to answer.
 - 1-4-4-2 WHEN the MS answers:
 - 1-4-4-2-1 IF an AnnouncementList parameter is received:

1 1-4-4-2-1-1 Execute the “Play All Announcements in the
2 AnnouncementList” task (see 3.2.5).
3
4 1-4-4-2-1-2 Include the AlertResult parameter set to *Success*.
5 1-4-4-2-1-3 Return to the calling task.
6
7 1-4-4-2-2 ELSE (AnnouncementList parameter is not received):
8 1-4-4-2-2-1 Include the AlertResult parameter set to *Success*.
9 1-4-4-2-2-2 Return to the calling task.
10
11 1-4-4-2-3 ENDIF.
12 1-4-4-3 WHEN the alerting timer expires (the MS fails to answer):
13 1-4-4-3-1 Include the AlertResult parameter set to *Failure*.
14 1-4-4-3-2 Return to the calling task.
15
16 1-4-4-4 ENDWAIT.
17 1-4-5 ENDIF.
18
19 1-5 WHEN the page response timer expires (the MS fails to respond):
20 1-5-1 Include the AlertResult parameter set to *NoPageResponse*.
21 1-5-2 Return to the calling task.
22
23 1-6 ENDWAIT.
24
25 2 ENDIF.
26
27 3 IF an AnnouncementCode parameter is received:
28 3-1 IF the AnnouncementCode is requesting CallWaitingTone without standard or
29 custom announcements.
30 3-1-1 IF out-of-band notification is possible:
31 3-1-1-1 Order the MS to apply CallWaitingTone once now and again in 15
32 seconds if the call is not answered.
33
34 3-1-2 ELSE:
35 3-1-2-1 Apply the Call Waiting tone in-band once now and again in 15 seconds if
36 the call is not answered.
37
38 3-1-3 ENDIF.
39 3-2 ENDIF.
40
41 4 ENDIF.
42
43 5 Exit this task.

3.3.7 MSC Record the DMH Parameters

1 IF the MobileIdentificationNumber parameter is received:
2 1-1 Record the MobileIdentificationNumber parameter (see *DMH*).
3 2 ENDIF.
4 3 IF the ElectronicSerialNumber parameter is received:
5 3-1 Record the ElectronicSerialNumber parameter (see *DMH*).
6 4 ENDIF.
7 5 IF the BillingID parameter is received:
8 5-1 Record the BillingID (see *DMH*).
9
10

- | | | |
|------|--|----|
| 6 | ENDIF. | 1 |
| 7 | IF the DMH_AccountCodeDigits parameter is received: | 2 |
| 7-1 | Record the DMH_AccountCodeDigits (see <i>DMH</i>). | 3 |
| 8 | ENDIF. | 4 |
| 9 | IF the DMH_AlternateBillingDigits parameter is received: | 5 |
| 9-1 | Record the DMH_AlternateBillingDigits (see <i>DMH</i>). | 6 |
| 10 | ENDIF. | 7 |
| 11 | IF the DMH_BillingDigits parameter is received: | 8 |
| 11-1 | Record the DMH_BillingDigits (see <i>DMH</i>). | 9 |
| 12 | ENDIF. | 10 |
| 13 | IF the DMH_RedirectionIndicator parameter is received: | 11 |
| 13-1 | Record the DMH_RedirectionIndicator (see <i>DMH</i>). | 12 |
| 14 | ENDIF. | 13 |
| 15 | Return to the calling task. | 14 |
| | | 15 |
| | | 16 |
| | | 17 |
| | | 18 |
| | | 19 |
| | | 20 |
| | | 21 |
| | | 22 |
| | | 23 |
| | | 24 |
| | | 25 |
| | | 26 |
| | | 27 |
| | | 28 |
| | | 29 |
| | | 30 |
| | | 31 |
| | | 32 |
| | | 33 |
| | | 34 |
| | | 35 |
| | | 36 |
| | | 37 |
| | | 38 |
| | | 39 |
| | | 40 |
| | | 41 |
| | | 42 |
| | | 43 |
| | | 44 |
| | | 45 |
| | | 46 |
| | | 47 |
| | | 48 |
| | | 49 |
| | | 50 |
| | | 51 |
| | | 52 |
| | | 53 |
| | | 54 |
| | | 55 |
| | | 56 |
| | | 57 |
| | | 58 |
| | | 59 |
| | | 60 |

3.3.8 MSC Route the Call Leg Externally

Upon request, the MSC shall do the following:

- | | | |
|------|--|----|
| 1 | Execute the “MSC Record the DMH Parameters” task (see 3.3.7). | 26 |
| 2 | IF the DMH_BillingDigits parameter is received: | 27 |
| 2-1 | Use the DMH_BillingDigits as the ISUP Charge Number or Automatic Number Identification (ANI). | 28 |
| 3 | ELSEIF the MobileDirectoryNumber parameter is received: | 29 |
| 3-1 | Use the MobileDirectoryNumber as the ISUP Charge Number or Automatic Number Identification (ANI). | 30 |
| 4 | ELSE: | 31 |
| 4-1 | Use the MobileIdentificationNumber as the ISUP Charge Number or Automatic Number Identification (ANI). | 32 |
| 5 | ENDIF. | 33 |
| 6 | IF the RoutingDigits parameter is received: | 34 |
| 6-1 | Analyze the routing digits to select an internal trunk group or an external network address (such as, a roamer port, a private network hop-on point, virtual private network hop-off point). | 35 |
| 7 | ENDIF. | 36 |
| 8 | IF the Digits (Carrier) parameter is received AND IF Carrier selection is appropriate: | 37 |
| 8-1 | Select the interexchange carrier based on the Digits (Carrier) digits. | 38 |
| 9 | ELSE: | 39 |
| 9-1 | Select the interexchange carrier based on internal algorithms. | 40 |
| 10 | ENDIF. | 41 |
| 11 | IF the ElectronicSerialNumber parameter is received within the IntersystemTermination parameter. | 42 |
| 11-1 | Associate the ElectronicSerialNumber parameter with this call. | 43 |
| 12 | ENDIF. | 44 |
| | | 45 |
| | | 46 |
| | | 47 |
| | | 48 |
| | | 49 |
| | | 50 |
| | | 51 |
| | | 52 |
| | | 53 |
| | | 54 |
| | | 55 |
| | | 56 |
| | | 57 |
| | | 58 |
| | | 59 |
| | | 60 |

1 13 IF the LegInformation parameter is received:
2
3 13-1 Store the LegInformation parameter to control subsequent redirections.
4 13-2 IF a BillingID parameter is received:
5 13-2-1 Associate the terminating BillingID parameter with this leg.
6 13-3 ENDIF.
7
8 14 ENDIF.
9
10 15 IF a PC_SSN parameter is received:
11 15-1 Store the PC_SSN for screening future call redirection attempts of this leg.
12 16 ENDIF.
13
14 17 IF an MSCID parameter is received:
15 17-1 Store the MSCID for screening future call redirection attempts of this leg.
16 18 ENDIF.
17
18 19 IF an MSCIdentificationNumber parameter is received:
19 19-1 Store the MSCIdentificationNumber for screening future call redirection attempts
20 of this leg.
21 20 ENDIF.
22
23 21 IF this is a call is originated by an MS at this MSC:
24 21-1 Execute the “MSC CNIP Originating Call Invocation” task (see 5.8.3).
25 22 ELSE (call must be being redirected at this MSC):
26 22-1 Execute the “MSC CNIP Redirecting Call Invocation” task (see 5.8.5).
27 23 ENDIF.
28
29 24 IF the TerminationTriggers parameter is received.
30 24-1 Use these TerminationTriggers instead of the profile event triggers for this call.
31 25 ENDIF.
32
33 26 IF a Digits (Destination) parameter is received:
34 26-1 Set destination to Digits (Destination).
35
36 27 ELSE IntersystemTermination parameter is received.
37 27-1 Set destination to the DestinationDigits parameter within the
38 IntersystemTermination parameter.
39 27-2 Set MSCID for this leg to the MSCID parameter within the
40 IntersystemTermination parameter.
41 27-3 IF the BillingID parameter is received within the IntersystemTermination
42 parameter.
43 27-3-1 Associate the terminating BillingID parameter with this call leg.
44 27-4 ENDIF.
45 27-5 IF the CarrierDigits parameter is received within the IntersystemTermination
46 parameter.
47 27-5-1 Use these carrier digits instead of other carrier digits.
48 27-6 ENDIF.
49 27-7 IF the ElectronicSerialNumber parameter is received within the
50 IntersystemTermination parameter.
51 27-7-1 Associate the ElectronicSerialNumber parameter with this call leg.
52
53
54
55
56
57
58
59
60

27-8	ENDIF.	1
27-9	IF the LegInformation parameter is receive within the IntersystemTermination parameter.	2
		3
		4
27-9-1	Associate the LegInformation parameter with this call leg.	5
27-10	ENDIF.	6
		7
27-11	IF the MobileIdentificationNumber parameter is received within the IntersystemTermination parameter.	8
		9
27-11-1	Associate the MobileIdentificationNumber parameter with this call leg.	10
27-12	ENDIF.	11
		12
27-13	IF the MSCIdentificationNumber parameter is received within the IntersystemTermination parameter.	13
		14
27-13-1	Associate the MSCIdentificationNumber with this call leg.	15
27-14	ENDIF.	16
		17
27-15	IF the RoutingDigits parameter is received within the IntersystemTermination parameter.	18
		19
27-15-1	Use these routing digits instead of other routing digits for this call leg.	20
27-16	ENDIF.	21
		22
27-17	IF the TerminationTriggers parameter is received within the IntersystemTermination parameter.	23
		24
27-17-1	Use these TerminationTriggers instead of other event triggers for this call leg.	25
27-18	ENDIF.	26
		27
28	ELSEIF PSTNTermination parameter is received.	28
		29
28-1	Set destination to DestinationDigits within the PSTNTermination parameter.	30
28-2	IF the CarrierDigits parameter is received within the PSTNTermination parameter.	31
		32
28-2-1	Use these carrier digits instead of other carrier digits.	33
28-3	ENDIF.	34
		35
28-4	IF the ElectronicSerialNumber parameter is received within the PSTNTermination parameter.	36
		37
28-4-1	Associate the ElectronicSerialNumber parameter with this call leg.	38
28-5	ENDIF.	39
		40
28-6	IF the LegInformation parameter is received within the PSTNTermination parameter.	41
		42
28-6-1	Associate the LegInformation with this call leg.	43
28-7	ENDIF.	44
		45
28-8	IF the MobileIdentificationNumber parameter is received within the PSTNTermination parameter.	46
		47
28-8-1	Associate the MobileIdentificationNumber parameter with this call leg.	48
28-9	ENDIF.	49
		50
28-10	IF the RoutingDigits parameter is received within the PSTNTermination parameter.	51
		52
28-10-1	Use these routing digits instead of other routing digits for this call leg.	53
28-11	ENDIF.	54
		55
		56
		57
		58
		59
		60

1 28-12 IF the TerminationTriggers parameter is received within the PSTNTermination
2 parameter.
3
4 28-12-1 Use these TerminationTriggers instead of other triggers for this call leg.
5 28-13 ENDIF.
6
7 29 ELSE (Digits (Destination), IntersystemTermination, OR PSTNTermination
8 parameter not received):
9 29-1 Return to the calling task.
10 30 ENDIF.
11
12 31 Process a call setup toward the destination via the route and selected carrier.
13 32 Cut through the voice path in the reverse direction (to allow the calling party to hear
14 call process tones).
15 33 Start an alerting timer.
16
17 34 IF the TerminationTriggers parameter is received:
18 34-1 Store the TerminationTriggers parameter for this leg.
19 34-2 IF the *NoAnswer* trigger is requested in the TerminationTriggers parameter.
20 34-2-1 IF the NoAnswerTime parameter is received:
21 34-2-1-1 Start a no answer timer with the value in the received NoAnswerTime
22 parameter.
23 34-2-2 ELSE:
24 34-2-2-1 Start a no answer timer with a system default value.
25 34-2-3 ENDIF.
26 34-3 ENDIF.
27
28 35 ENDIF.
29
30 36 WAIT for the trunk to be answered.
31
32 37 WHEN a routing failure is detected:
33 37-1 IF the *RoutingFailure* termination trigger point is active:
34 37-1-1 Include the RedirectionReason parameter set to *Unroutable*.
35 37-1-2 IF this call has requested the *None Reachable* termination trigger AND IF
36 this is the last leg AND IF a GroupInformation parameter was received:
37 37-1-2-1 Include the GroupInformation parameter.
38 37-1-3 ELSEIF the LegInformation parameter was received:
39 37-1-3-1 Include the LegInformation parameter.
40 37-1-4 ENDIF.
41 37-1-5 Execute the “MSC Initiating a Transfer-To-Number Request” task (see
42 4.49.1).
43 37-2 ELSE:
44 37-2-1 Remain in this state (to wait for the calling party to disconnect).
45 37-3 ENDIF.
46
47 38 WHEN a busy is detected:
48 38-1 IF the *Busy* termination trigger point is active:
49 38-1-1 Include the RedirectionReason parameter set to *Busy* .
50 38-1-2 IF this call has requested the *None Reachable* termination trigger AND IF
51 this is the last leg AND IF a GroupInformation parameter was received:
52
53
54
55
56
57
58
59
60

38-1-2-1	Include the GroupInformation parameter.	1
38-1-3	ELSEIF the LegInformation parameter was received:	2
38-1-3-1	Include the LegInformation parameter.	3
38-1-4	ENDIF.	4
38-1-5	Execute the “MSC Initiating a Transfer-To-Number Request ” task (see 4.49.1).	5
38-2	ELSE:	6
38-2-1	Remain in this state (to wait for the calling party to disconnect).	7
38-2-2	ENDIF.	8
38-3	ENDIF.	9
39	WHEN the trunk is answered:	10
39-1	Cut through the voice path in the forward direction (to allow the calling party to communicate with the called party).	11
40	WHEN the trunk disconnect is detected:	12
40-1	Release the trunk.	13
41	WHEN the alerting timer expires:	14
41-1	Connect the calling party to an announcement or tone to indicate that the called party is not answering.	15
42	WHEN the no answer timer expires:	16
42-1	Include the RedirectionReason parameter set to <i>No Answer</i> .	17
42-2	IF this call has requested the <i>None Reachable</i> termination trigger AND IF this is the last leg AND IF a GroupInformation parameter was received:	18
42-2-1	Include the GroupInformation parameter.	19
42-3	ELSEIF the LegInformation parameter was received:	20
42-3-1	Include the LegInformation parameter.	21
42-4	ENDIF.	22
42-5	Execute the “MSC Initiating a Transfer-To-Number Request” task (see 4.49.1).	23
43	ENDWAIT.	24
44	Exit this task.	25

3.4 DISCONNECT CALL TASKS

3.4.1 MS Disconnect

1	IF the current system is the Anchor MSC:	26
1-1	IF this was not a simple feature code access:	27
1-1-1	Clear the OneTimeFeatureIndicator parameter.	28
1-1-2	Clear the Conference Calling internal processing mode.	29
1-2	ENDIF.	30
2	ENDIF.	31
3	FOR all of the other legs associated with this leg:	32
3-1	Disconnect leg.	33

- 4 ENDFOR.
- 5 IF the current system is the serving system:
 - 5-1 Release the voice channel to the MS.
- 6 ENDIF.
- 7 Exit this task.

3.4.2 Other Party Disconnect

- 1 IF the other party was the only party in an active connection (i.e., not in a 3WC, CC, or on hold):
 - 1-1 IF this was not a simple feature code access:
 - 1-1-1 Clear the OneTimeFeatureIndicator parameter.
 - 1-1-2 Clear the Conference Calling internal processing mode.
 - 1-2 ENDIF.
- 2 ENDIF.
- 3 IF the MSC is the Serving MSC:
 - 3-1 Release the voice channel to the MS.
- 4 ENDIF.
- 5 Exit this task.

3.4.3 Commanded Disconnect

- 1 IF the MSC is the Anchor MSC:
 - 1-1 IF the other party was the only party in an active connection (i.e., not in a 3WC, CC, or on hold):
 - 1-1-1 IF this was not a simple feature code access:
 - 1-1-1-1 Clear the OneTimeFeatureIndicator parameter.
 - 1-1-1-2 Clear the Conference Calling internal processing mode.
 - 1-1-2 ENDIF.
 - 1-2 ENDIF.
 - 1-3 FOR all of the other legs associated with this leg:
 - 1-3-1 Disconnect leg.
 - 1-4 ENDFOR.
- 2 ENDIF.
- 3 IF the current system is the serving system:
 - 3-1 Release the voice channel to the MS.
- 4 ELSE:
 - 4-1 Release the handoff trunk toward the serving system.
- 5 ENDIF.
- 6 Exit this task.

3.4.4 Apply Busy Treatment

When an MSC is requested to apply busy treatment, it shall do the following:

- 1 Apply busy tone.
- 2 WAIT for the call to disconnect:
- 3 WHEN the call disconnects:
 - 3-1 (Fall through.)
- 4 ENDWAIT.
- 5 Exit this task.

3.4.5 Apply Access Denial Treatment

When an MSC is requested to apply access denial treatment, it shall do the following:

- 1 IF an announcement is available in the subscriber's preferred language:
 - 1-1 Play an announcement in the subscriber's preferred language.
- 2 ELSEIF a system default announcement is available:
 - 2-1 Play the announcement is in the system's default language.
- 3 ELSE:
 - 3-1 Play reorder tone.
- 4 ENDIF.
- 5 WAIT for the call to disconnect.
- 6 WHEN the call disconnects:
 - 6-1 Release the call resources and the announcement.
- 7 ENDWAIT.
- 8 Exit this task.

3.5 RECOVERY CALL TASKS

3.5.1 Local Recovery Procedures

When a functional entity detects an abnormal condition, it may perform the following actions as determined by internal algorithms and the specific condition encountered.

- 1 Record the abnormal condition.
- 2 Report the abnormal condition.
- 3 IF appropriate:
 - 3-1 Execute "Apply Access Denial Treatment" task (see 3.4.5).
- 4 ENDIF.
- 5 IF the functional entity initiated the particular transaction:
 - 5-1 IF the operation does not involve a call or other transient information:
 - 5-1-1 IF the locally specified retry count has not been exceeded:
 - 5-1-1-1 Reschedule the operation for attempting later.

- 1 5-1-2 ENDIF.
 2
 3 5-2 ENDIF.
 4 6 ENDIF.
 5 7 IF state variables are unknown due to the failure:
 6 7-1 Attempt to get each state variable into a known or safe condition.
 7 8 ENDIF.
 8 9 IF resources remain seized:
 9 9-1 Release the seized resources.
 10 10 ENDIF.
 11 11 Exit this task indicating *operation failed*.

3.6 HANDOFF CALL TASKS

3.6.1 Serving MSC Initiating a Handoff

When the Serving MSC determines that a call should be handed off using the MSC's internal algorithm, it shall do the following:

- 1 IF the call in progress currently has the DTX (Discontinuous) mode active:
 1-1 IF the Target MSC is known to not support the DTX mode:
 1-1-1 Remove the call from the DTX mode (if possible).
 1-2 ENDIF.
 2 ENDIF.
 3 IF the Target MSC is known to not support the current call mode:
 3-1 Assign the MS to a voice or traffic channel known to be supported by the Target MSC (if possible).
 4 ENDIF.
 5 IF the Target MSC and the Serving MSC are connected via an inter-MSC trunk for the same call AND IF the Serving MSC is not the Anchor MSC:
 5-1 Execute the "Serving MSC Initiating a Handoff Back" task (see 4.16.1).
 6 ELSEIF path minimization is provisioned AND IF the Serving MSC is not the Anchor MSC:
 6-1 Execute "Serving MSC Initiating a Handoff-To-Third Directive" task (see 4.20.1).
 7 ELSE (Serving MSC is the Anchor OR Target and Serving MSCs are not interconnected OR path minimization is not provisioned):
 7-1 Execute "Serving MSC Initiating a Facilities Directive" task (see 4.11.1).
 8 ENDIF.
 9 Exit this task.

4 INTERSYSTEM PROCEDURES

4.1 AUTHENTICATION DIRECTIVE

4.1.1 AC Initiation of an Authentication Directive

When an AC determines that the authentication parameters associated with an MS must be changed, it shall start the authentication directive process. For example, the authentication parameters may be changed due to AC administrative procedures, when an authentication abnormality is detected or periodically.

The AC shall perform the following:

- 1 Include the ElectronicSerialNumber parameter set to identify the MS.
- 2 Include the MobileIdentificationNumber parameter set to identify the MS.
- 3 IF SharedSecretData (SSD) presently shared with the VLR shall be discarded:
 - 3-1 Include the SSDNotShared (NOSSD) parameter.
 - 4 ENDIF.
 - 5 IF an SSD update shall be initiated:
 - 5-1 Select a RandomVariableSSD (RANDSSD) and execute CAVE using the value of the MS's A-key recorded in the AC's database to produce a pending SSD.
 - 5-2 Include the RandomVariableSSD (RANDSSD) parameter.
 - 5-3 Mark the MS *pending SSD update*.
 - 5-4 IF AC administrative procedures indicate that the pending SSD shall be shared with the VLR for the SSD update operation:
 - 5-4-1 IF the VLR's SystemCapabilities (SYSCAP) indicates that the VLR is able to execute the CAVE algorithm:
 - 5-4-1-1 Include the SharedSecretData (SSD) parameter set to the pending SSD value.
 - 5-4-1-2 IF the AuthenticationAlgorithmVersion (AAV) parameter for this MS is different than the default value:
 - 5-4-1-2-1 Include the AuthenticationAlgorithmVersion (AAV) parameter.
 - 5-4-1-3 ENDIF.
 - 5-4-2 ENDIF.
 - 5-5 ELSE (the SharedSecretData (SSD) is not to be shared):
 - 5-5-1 Select a RandomVariableUniqueChallenge (RANDU) and execute CAVE using the value of the pending SSD to produce an AuthenticationResponseUnique (AUTHU).
 - 5-5-2 Include the RandomVariableUniqueChallenge (RANDU) and AuthenticationResponseUnique (AUTHU) parameters.
 - 5-5-3 Mark the MS *pending Unique Challenge*.
 - 5-6 ENDIF.
 - 6 ELSE (SSD update not initiated):

- 1
2
3
4
5
6
7
8
9
10
11
12
13
14
15
16
17
18
19
20
21
22
23
24
25
26
27
28
29
30
31
32
33
34
35
36
37
38
39
40
41
42
43
44
45
46
47
48
49
50
51
52
53
54
55
56
57
58
59
60
- 6-1 IF the SharedSecretData (SSD) shall be shared with the VLR:
 - 6-1-1 IF the VLR's SystemCapabilities (SYSCAP) indicates the VLR is capable of executing the CAVE algorithm:
 - 6-1-1-1 Include the SharedSecretData (SSD) and CallHistoryCount (COUNT) parameters.
 - 6-1-1-2 IF the AuthenticationAlgorithmVersion (AAV) parameter for this MS is different than the default value.
 - 6-1-1-2-1 Include the AuthenticationAlgorithmVersion (AAV) parameter.
 - 6-1-1-3 ENDIF.
 - 6-1-2 ENDIF.
 - 6-2 ENDIF.
 - 6-3 IF a Unique Challenge shall be initiated:
 - 6-3-1 Select a RandomVariableUniqueChallenge (RANDU) and execute CAVE using the value of the MS's SharedSecretData (SSD) recorded in the AC's database to produce an AuthenticationResponseUnique (AUTHU)..
 - 6-3-2 Include the RandomVariableUniqueChallenge (RANDU) and AuthenticationResponseUnique (AUTHU) parameters.
 - 6-3-3 Mark the MS *pending Unique Challenge*.
 - 6-4 ENDIF.
 - 7 ENDIF.
 - 8 IF a COUNT update shall be initiated:
 - 8-1 Include the UpdateCount (UPDCOUNT) parameter.
 - 8-2 Mark the MS *pending COUNT update*.
 - 9 ENDIF.
 - 10 Send an AuthenticationDirective INVOKE to the HLR associated with the MS.
 - 11 Start the Authentication Directive Timer (ADT).
 - 12 WAIT for an Authentication Directive response:
 - 13 WHEN a RETURN RESULT is received:
 - 13-1 Stop timer (ADT).
 - 13-2 IF the message can be processed:
 - 13-2-1 IF the CallHistoryCount (COUNT) parameter is received:
 - 13-2-1-1 Store the received CallHistoryCount (COUNT) value.
 - 13-2-2 ENDIF
 - 13-2-3 IF the MS is marked *pending SSD update*, OR IF the MS is marked *pending Unique Challenge*, OR IF the MS is marked *pending COUNT update*:
 - 13-2-3-1 Execute the "AC Awaiting AuthenticationStatusReport INVOKE" task (see 4.5.4).
 - 13-2-4 ENDIF.
 - 13-2-5 Exit this task.
 - 13-3 ELSE (the message cannot be processed):
 - 13-3-1 IF the MS is marked *pending SSD update*:
 - 13-3-1-1 IF the MS's pending SSD is stored in the AC's database.
 - 13-3-1-1-1 Remove the pending SSD from the AC's database.

13-3-1-2	ENDIF.	1
13-3-2	ENDIF.	2
13-3-3	Clear all the MS's pending operation flags.	3
13-3-4	Execute the "Local Recovery Procedures" task (see 3.5.1).	4
13-3-5	Return to the invoking process.	5
13-4	ENDIF.	6
14	WHEN a RETURN ERROR or REJECT is received:	7
14-1	Stop timer (ADT).	8
14-2	IF the MS is marked <i>pending SSD update</i> :	9
14-2-1	IF the MS's pending SSD is stored in the AC's database.	10
14-2-1-1	Remove the pending SSD from the AC's database.	11
14-2-2	ENDIF.	12
14-3	ENDIF.	13
14-4	Clear all the MS's pending operation flags.	14
14-5	Execute the "Local Recovery Procedures " task (see 3.5.1).	15
14-6	Return to the invoking process.	16
15	WHEN timer (ADT) expires:	17
15-1	IF the MS is marked <i>pending SSD update</i> :	18
15-1-1	IF the MS's pending SSD is stored in the AC's database.	19
15-1-1-1	Remove the pending SSD from the AC's database.	20
15-1-2	ENDIF.	21
15-2	ENDIF.	22
15-3	Clear all the MS's pending operation flags.	23
15-4	Execute the "Local Recovery Procedures " task (see 3.5.1).	24
15-5	Return to the invoking process.	25
16	ENDWAIT.	26

4.1.2 HLR Receiving AuthenticationDirective INVOKE

When an HLR receives an AuthenticationDirective INVOKE, it shall perform the following:

1	IF the received message can be processed:	27
1-1	Include the SenderIdentificationNumber set to the identification number of the HLR.	28
1-2	Relay all other received parameters.	29
1-3	Send an AuthenticationDirective INVOKE to the VLR currently serving the MS.	30
1-4	Start the Authentication Directive Timer (ADT).	31
1-5	WAIT for an Authentication Directive response:	32
1-6	WHEN a RETURN RESULT is received:	33
1-6-1	Stop timer (ADT).	34
1-6-2	IF the message can be processed:	35
1-6-2-1	Relay all received parameters.	36

1 1-6-2-2 Send a RETURN RESULT to the requesting AC.
2 1-6-2-3 Exit this task.
3
4 1-6-3 ELSE (the message cannot be processed):
5 1-6-3-1 Send a RETURN ERROR to the requesting AC.
6 1-6-3-2 Execute the “Local Recovery Procedures ” task (see 3.5.1).
7 1-6-3-3 Exit this task.
8
9 1-6-4 ENDF.
10
11 1-7 WHEN a RETURN ERROR or REJECT is received:
12 1-7-1 Stop timer (ADT).
13 1-7-2 CASE Error Code OF:
14 1-7-3 *ParameterError*:
15 1-7-3-1 IF the parameter was originated from the initiating functional entity:
16 1-7-3-1-1 Send a RETURN ERROR with Error Code set to indicate
17 *ParameterError*.
18 1-7-3-2 ELSE:
19 1-7-3-2-1 Send a RETURN ERROR with Error Code set to indicate
20 *SystemFailure*.
21 1-7-3-3 ENDF.
22 1-7-4 *OperationSequenceProblem*:
23 1-7-4-1 Send a RETURN ERROR with Error Code set to indicate
24 *OperationSequenceProblem*.
25 1-7-5 *DEFAULT*:
26 1-7-5-1 Send a RETURN ERROR with Error Code set to indicate *SystemFailure*.
27 1-7-6 ENDCASE.
28 1-7-7 Execute the “Local Recovery Procedures ” task (see 3.5.1).
29 1-7-8 Exit this task.
30 1-8 WHEN timer (ADT) expires:
31 1-8-1 Send a RETURN ERROR with Error Code set to indicate *SystemFailure*.
32 1-8-2 Execute the “Local Recovery Procedures ” task (see 3.5.1).
33 1-8-3 Exit this task.
34 1-9 ENDWAIT.
35 2 ELSE (the received message cannot be processed):
36 2-1 Send a RETURN ERROR with the proper Error Code value (see the following
37 table) to the requesting AC.
38 3 ENDF.
39 4 Exit this task.
40
41
42
43
44
45
46
47
48
49
50
51
52
53
54
55
56
57
58
59
60

Table 1 HLR Authentication Directive Response

Problem Detection and Recommended Response from HLR to AC												
PROBLEM DEFINITION	1	2	3	4	5	6	7	8	9	10	11	Notes
RETURN ERROR Error Code												
<i>UnrecognizedMIN</i>							X					e
<i>UnrecognizedESN</i>									X			e
<i>MIN/HLRMismatch</i>						X						
<i>OperationSequenceProblem</i>										X		e
<i>ResourceShortage</i>		X										e
<i>OperationNotSupported</i>	X											b, e
<i>TrunkUnavailable</i>												a
<i>ParameterError</i>				X								d, e
<i>SystemFailure</i>			X									e
<i>UnrecognizedParameterValue</i>					X							d, e
<i>FeatureInactive</i>												a
<i>MissingParameter</i>								X				d, e
RETURN RESULT											X	c, e

Problem Detections:

1. The requested MAP operation is recognized, but not supported, by the receiving HLR, or the requesting functional entity is not authorized.
2. A required HLR resource (e.g., internal memory record, HLR is fully occupied) is temporarily not available (e.g., congestion).
3. A required resource (e.g., data base access, functional entity) is not presently accessible due to a failure. Human intervention may be required for resolution.
4. A supplied parameter value has an encoding problem (e.g., The supplied MobileIdentificationNumber parameter digit values do not meet the BCD specification).
5. A supplied parameter value is unrecognized or has nonstandard values (e.g., *Not used*).
6. The supplied MobileIdentificationNumber parameter is not in the HLR's range of MINs or directory numbers (suspect routing error).
7. The supplied MobileIdentificationNumber parameter is within the range of the HLR, but the MIN is not Authentication capable or authorized.
8. An optional parameter required by the HLR was expected, but not received (e.g., only MobileIdentificationNumber and ElectronicSerialNumber parameters received).
9. The supplied MobileIdentificationNumber parameter is within the range of the HLR, but the supplied ElectronicSerialNumber parameter is not valid for the MIN's authentication record.
10. The HLR has another Authentication process in-progress for the supplied MobileIdentificationNumber parameter.
11. The HLR supports Authentication, but it does not support the requested Authentication feature (e.g., Count updates, Sharing secret data), initiate an AuthenticationStatusReport INVOKE.

Notes:

- a. This Error Code is not an appropriate HLR response to an AuthenticationDirective transaction.
- b. It is recommended that an HLR supports AuthenticationDirective transactions.
- c. Only RETURN RESULT operations needing clarification have been included.
- d. Include the *Parameter Identifier* in question as the FaultyParameter parameter.
- e. This response may have been originated by the VLR (MSC).

4.1.3 VLR Receiving AuthenticationDirective INVOKE

When a VLR receives an AuthenticationDirective INVOKE, it shall perform the following:

- 1 IF the received message can be processed:
 - 1-1 IF the SSDNotShared (NOSSD) parameter is received:
 - 1-1-1 Remove the MS's current SharedSecretData (SSD) and AuthenticationAlgorithmVersion (AAV) from the VLR's database.
 - 1-2 ENDIF.
 - 1-3 IF the RandomVariableSSD (RANDSSD) parameter is received:
 - 1-3-1 IF SharedSecretData (SSD) is shared:
 - 1-3-1-1 Remove the MS's current SharedSecretData (SSD) and AuthenticationAlgorithmVersion (AAV) from the VLR's database.
 - 1-3-2 ENDIF.
 - 1-3-3 Relay the received RandomVariableSSD (RANDSSD) parameter.
 - 1-3-4 Mark the MS *pending SSD update*.
 - 1-3-5 IF the SharedSecretData (SSD) parameter is received:
 - 1-3-5-1 Store the pending SharedSecretData (SSD) value.
 - 1-3-5-2 IF the AuthenticationAlgorithmVersion (AAV) parameter is received:
 - 1-3-5-2-1 Store the received AuthenticationAlgorithmVersion (AAV) value.
 - 1-3-5-3 ENDIF.
 - 1-3-5-4 IF the CallHistoryCount (COUNT) parameter is received:
 - 1-3-5-4-1 Store the received CallHistoryCount (COUNT) value.
 - 1-3-5-5 ENDIF.
 - 1-3-5-6 Select a RandomVariableUniqueChallenge (RANDU) and execute CAVE using the value of the pending SSD to produce an AuthenticationResponseUnique (AUTHU).
 - 1-3-5-7 Include the RandomVariableUniqueChallenge (RANDU) and AuthenticationResponseUnique (AUTHU) parameters.
 - 1-3-5-8 Mark the MS *pending Unique Challenge*.
 - 1-3-6 ELSE (pending SSD is not shared):
 - 1-3-6-1 Relay the RandomVariableUniqueChallenge (RANDU) parameter.
 - 1-3-6-2 Relay the AuthenticationResponseUnique (AUTHU) parameter.
 - 1-3-6-3 Mark the MS *pending Unique Challenge*.
 - 1-3-7 ENDIF.
 - 1-4 ELSE (an SSD update is not requested by the AC):
 - 1-4-1 IF the SharedSecretData (SSD) parameter is received:
 - 1-4-1-1 Store the received pending SharedSecretData (SSD) .
 - 1-4-1-2 IF the AuthenticationAlgorithmVersion (AAV) parameter is received:
 - 1-4-1-2-1 Store the AuthenticationAlgorithmVersion (AAV) value.
 - 1-4-1-3 ENDIF.
 - 1-4-1-4 IF the CallHistoryCount (COUNT) parameter is received:
 - 1-4-1-4-1 Store the received CallHistoryCount (COUNT) value.

1-4-1-5	ENDIF.	1
1-4-2	ENDIF.	2
1-4-3	IF the RandomVariableUniqueChallenge (RANDU) and AuthenticationResponseUnique (AUTHU) parameters are received:	3
1-4-3-1	Relay the received RandomVariableUniqueChallenge (RANDU) and AuthenticationResponseUnique (AUTHU) parameters.	4
1-4-3-2	Mark the MS <i>pending Unique Challenge</i> .	5
1-4-4	ENDIF.	6
1-5	ENDIF.	7
1-6	IF the UpdateCount (UPDCOUNT) parameter is received:	8
1-6-1	Relay the received UpdateCount (UPDCOUNT) parameter.	9
1-6-2	Mark the MS <i>pending COUNT update</i> .	10
1-7	ENDIF.	11
1-8	Optionally include the LocationAreaID parameter.	12
1-9	IF the MS is not marked <i>pending SSD update</i> , AND IF the MS is not marked <i>pending Unique Challenge</i> , AND IF the MS is not marked <i>pending COUNT update</i> , AND IF sharing SSD is off:	13
1-9-1	IF the CallHistoryCount (COUNT) is available:	14
1-9-1-1	Include the CallHistoryCount (COUNT) parameter.	15
1-9-2	ENDIF.	16
1-9-3	Send an AuthenticationDirective RETURN RESULT to the requesting HLR.	17
1-9-4	Exit this task.	18
1-10	ELSE (the MS is marked <i>pending SSD update</i> , OR the MS is marked <i>pending Unique Challenge</i> , OR the MS is marked <i>pending COUNT update</i>):	19
1-10-1	Include the SenderIdentificationNumber set to the identification number of the VLR.	20
1-10-2	Send an AuthenticationDirective INVOKE to the MSC currently serving the MS.	21
1-10-3	Start the Authentication Directive Timer (ADT).	22
1-10-4	WAIT for an Authentication Directive response:	23
1-10-5	WHEN a RETURN RESULT is received:	24
1-10-5-1	Stop timer (ADT).	25
1-10-5-2	IF the message can be processed:	26
1-10-5-2-1	IF the CallHistoryCount (COUNT) is available:	27
1-10-5-2-1-1	Include the CallHistoryCount (COUNT) parameter.	28
1-10-5-2-2	ENDIF.	29
1-10-5-2-3	Send a RETURN RESULT to the requesting HLR.	30
1-10-5-2-4	Execute the "VLR Awaiting AuthenticationStatusReport INVOKE" task (see 4.5.2).	31
1-10-5-2-5	Exit this task.	32
1-10-5-3	ELSE (the message cannot be processed):	33
1-10-5-3-1	Send a RETURN ERROR to the requesting HLR.	34
1-10-5-3-2	IF the MS is marked <i>pending SSD update</i> :	35
		36
		37
		38
		39
		40
		41
		42
		43
		44
		45
		46
		47
		48
		49
		50
		51
		52
		53
		54
		55
		56
		57
		58
		59
		60

1 1-10-5-3-2-1 IF the pending SSD is stored in the VLR's database:
2
3 1-10-5-3-2-1-1 Remove the MS's pending SSD and
4 AuthenticationAlgorithmVersion (AAV) from the VLR's
5 database.
6 1-10-5-3-2-2 ENDIF.
7
8 1-10-5-3-3 ENDIF.
9
10 1-10-5-3-4 Clear all the MS's pending operation flags.
11 1-10-5-3-5 Execute "Local Recovery Procedures" task (see 3.5.1).
12 1-10-5-3-6 Exit this task.
13 1-10-5-4 ENDIF.
14
15 1-10-6 WHEN a RETURN ERROR or REJECT is received:
16 1-10-6-1 Stop timer (ADT).
17 1-10-6-2 CASE Error Code OF:
18 1-10-6-3 *ParameterError*:
19
20 1-10-6-3-1 IF the parameter was originated from the initiating functional entity:
21 1-10-6-3-1-1 Send a RETURN ERROR with the Error Code indicating
22 *ParameterError*.
23
24 1-10-6-3-2 ELSE:
25 1-10-6-3-2-1 Send a RETURN ERROR with the Error Code indicating
26 *SystemFailure*.
27
28 1-10-6-3-3 ENDIF.
29 1-10-6-4 *OperationSequenceProblem*:
30 1-10-6-4-1 Send a RETURN ERROR with the Error Code indicating
31 *OperationSequenceProblem*.
32
33 1-10-6-5 *DEFAULT*:
34 1-10-6-5-1 Send a RETURN ERROR with the Error Code indicating
35 *SystemFailure*.
36
37 1-10-6-6 ENDCASE.
38 1-10-6-7 IF the MS is marked *pending SSD update*:
39 1-10-6-7-1 IF the pending SSD is stored in the VLR's database:
40 1-10-6-7-1-1 Remove the MS's pending SharedSecretData (SSD) and
41 AuthenticationAlgorithmVersion (AAV) from the VLR's
42 database.
43
44 1-10-6-7-2 ENDIF.
45
46 1-10-6-8 ENDIF.
47
48 1-10-6-9 Clear all the MS's pending operation flags.
49 1-10-6-10 Execute "Local Recovery Procedures" task (see 3.5.1).
50 1-10-6-11 Exit this task.
51 1-10-7 WHEN timer (ADT) expires:
52 1-10-7-1 Send a RETURN ERROR with the Error Code set to indicate
53 *SystemFailure*.
54
55 1-10-7-2 IF the MS is marked *pending SSD update*:
56 1-10-7-2-1 IF the pending SSD is stored in the VLR's database:

1-10-7-2-1-1 Remove the MS's pending SharedSecretData (SSD) and AuthenticationAlgorithmVersion (AAV) from the VLR's database.

1-10-7-2-2 ENDIF.

1-10-7-3 ENDIF.

1-10-7-4 Clear all the MS's pending operation flags.

1-10-7-5 Execute the "Local Recovery Procedures " task (see 3.5.1).

1-10-8 ENDWAIT.

1-11 ENDIF.

2 ELSE (the received message cannot be processed):

2-1 Send a RETURN ERROR to the requesting HLR.

3 ENDIF.

4 Exit this task.

Table 2 VLR AuthenticationDirective Response

Problem Detection and Recommended Response from VLR to HLR												
PROBLEM DEFINITION	1	2	3	4	5	6	7	8	9	10	11	Notes
RETURN ERROR Error Code												
<i>UnrecognizedMIN</i>						X						e
<i>UnrecognizedESN</i>								X				e
<i>MIN/HLRMismatch</i>												a
<i>OperationSequenceProblem</i>									X			e
<i>ResourceShortage</i>		X										e
<i>OperationNotSupported</i>	X											b, e
<i>TrunkUnavailable</i>												a
<i>ParameterError</i>				X								d, e
<i>SystemFailure</i>			X									e
<i>UnrecognizedParameterValue</i>					X							d, e
<i>FeatureInactive</i>												a
<i>MissingParameter</i>							X					d, e
RETURN RESULT										X	X	c, e

Problem Detections:

1. The requested MAP operation is recognized, but not supported, by the receiving VLR, or the requesting functional entity is not authorized.
2. A required VLR resource (e.g., internal memory record, VLR is fully occupied) is temporarily not available (e.g., congestion).
3. A required resource (e.g., data base access, functional entity) is not presently accessible due to a failure. Human intervention may be required for resolution.
4. A supplied parameter value has an encoding problem (e.g., The supplied MobileIdentificationNumber parameter digit values do not meet the BCD specification).
5. A supplied parameter value is unrecognized or has nonstandard values (e.g., *Not used*).
6. A VLR record does not presently exist for the supplied MobileIdentificationNumber parameter.
7. An optional parameter required by the VLR was expected, but not received (e.g., only MobileIdentificationNumber and ElectronicSerialNumber parameters received). A received optional parameter required the VLR to expect an additional optional parameter that was not received (e.g., RandomVariableSSD (RANDSSD) and SharedSecretData (SSD) or , RandomVariableSSD

(RANDSSD), RandomVariableUniqueChallenge (RANDU) and AuthenticationResponseUnique (AUTHU)).

8. A VLR record exists for the supplied MobileIdentificationNumber parameter, but the supplied ElectronicSerialNumber parameter does not match the ESN in the VLR record.
9. The VLR has another Authentication process in-progress for the supplied MobileIdentificationNumber parameter.
10. The VLR supports Authentication, but it does not support the requested Authentication feature (e.g., Count updates, Sharing secret data), initiate an AuthenticationStatusReport INVOKE.
11. The VLR supports Authentication, SSD is not presently being shared for the supplied MobileIdentificationNumber parameter, thus the VLR did not expect to receive a SSDNotShared(NOSSD) parameter.

Notes:

- a. This Error Code is not an appropriate VLR response to an AuthenticationDirective transaction.
- b. It is recommended that an VLR supports AuthenticationDirective transactions.
- c. Only RETURN RESULT operations needing clarification have been included.
- d. Include the *Parameter Identifier* in question as the FaultyParameter parameter.
- e. This response may have been originated by the MSC.

4.1.4 MSC Receiving AuthenticationDirective INVOKE

When an MSC receives an AuthenticationDirective INVOKE, it shall perform the following:

- 1 IF the received message can be processed:
 - 1-1 Send a RETURN RESULT to the VLR.
 - 1-2 Execute the “MSC Receiving Authentication Parameters” task (see 4.1.6) using the parameters received.
- 2 ELSE (the message cannot be processed):
 - 2-1 Send a RETURN ERROR to the VLR.
- 3 ENDIF.
- 4 Exit this task.

Table 3 MSC Authentication Directive Response

Problem Detection and Recommended Response from MSC to VLR												
PROBLEM DEFINITION	1	2	3	4	5	6	7	8	9	10	11	Notes
RETURN ERROR Error Code												
<i>UnrecognizedMIN</i>						X						
<i>UnrecognizedESN</i>								X				
<i>MIN/HLRMismatch</i>												a
<i>OperationSequenceProblem</i>									X			
<i>ResourceShortage</i>		X										
<i>OperationNotSupported</i>	X											b
<i>TrunkUnavailable</i>												a
<i>ParameterError</i>				X								d
<i>SystemFailure</i>			X									e
<i>UnrecognizedParameterValue</i>					X							d
<i>FeatureInactive</i>												a
<i>MissingParameter</i>							X					d
RETURN RESULT										X	X	c

Problem Detections:

- The requested MAP operation is recognized, but not supported, by the receiving MSC, or the requesting functional entity is not authorized.
- A required MSC resource (e.g., internal memory record, MSC is fully occupied) is temporarily not available (e.g., congestion).
- A required resource (e.g., data base access, functional entity) is not presently accessible due to a failure. Human intervention may be required for resolution.
- A supplied parameter value has an encoding problem (e.g., The supplied MobileIdentificationNumber parameter digit values do not meet the BCD specification).
- A supplied parameter value is unrecognized or has nonstandard values (e.g., *Not used*).
- An MSC record does not presently exist for the supplied MobileIdentificationNumber parameter.
- An optional parameter required by the MSC was expected, but not received (e.g., only MobileIdentificationNumber and ElectronicSerialNumber parameters received). A received optional parameter required the MSC to expect an additional optional parameter that was not received (e.g., RandomVariableSSD (RANDSSD), RandomVariableUniqueChallenge (RANDU) and AuthenticationResponseUnique (AUTHU)).
- An MSC record exists for the supplied MobileIdentificationNumber parameter, but the supplied ElectronicSerialNumber parameter does not match the ESN in the MSC record.
- The MSC has another Authentication process in-progress for the supplied MobileIdentificationNumber parameter.
- The MSC supports Authentication, but it does not support the requested Authentication feature (e.g., Count updates, Sharing of secret data), initiate an AuthenticationStatusReport INVOKE.
- The MSC supports Authentication, but it does not expect to receive the SSDNotShared (NOSSD) parameter.

Notes:

- This Error Code is not an appropriate MSC response to an AuthenticationDirective transaction.
- It is recommended that an MSC supports AuthenticationDirective transactions.
- Only RETURN RESULT operations needing clarification have been included.
- Include the *Parameter Identifier* in question as the FaultyParameter parameter.

4.1.5 VLR Initiating an Authentication Directive

When SharedSecretData (SSD) is shared and a VLR determines that the authentication parameters associated with an MS must be changed, it shall start the authentication directive process. For example, the authentication parameters may be changed due to VLR administrative procedures or periodically.

The VLR shall perform the following:

- 1 IF a Unique Challenge shall be initiated:
 - 1-1 Select a RandomVariableUniqueChallenge (RANDU) and execute CAVE using the value of the MS's SharedSecretData (SSD) recorded in the VLR's database to produce an AuthenticationResponseUnique (AUTHU).
 - 1-2 Include the RandomVariableUniqueChallenge (RANDU) and AuthenticationResponseUnique (AUTHU) parameters.
 - 1-3 Mark the MS *pending Unique Challenge*.
- 2 ENDIF.
- 3 IF a COUNT update shall be initiated:
 - 3-1 Include the UpdateCount (UPDCOUNT) parameter.
 - 3-2 Mark the MS *pending COUNT update*.
- 4 ENDIF.
- 5 Include the SenderIdentificationNumber set to the identification number of the sending functional entity.
- 6 Send an AuthenticationDirective INVOKE to the MSC serving the MS.
- 7 Start the Authentication Directive Timer (ADT).
- 8 WAIT for an Authentication Directive response:
- 9 WHEN a RETURN RESULT is received:
 - 9-1 Stop timer (ADT).
 - 9-2 IF the message can be processed:
 - 9-2-1 IF the MS is marked *pending Unique Challenge*, OR IF the MS is marked *pending COUNT update*:
 - 9-2-1-1 Execute the "VLR Awaiting AuthenticationStatusReport INVOKE" task (see 4.5.2).
 - 9-2-2 ENDIF.
 - 9-2-3 Return to the invoking process.
 - 9-3 ELSE (the message cannot be processed):
 - 9-3-1 Clear all the MS's pending operation flags.
 - 9-3-2 Execute the "Local Recovery Procedures" task (see 3.5.1).
 - 9-3-3 Return to the invoking process.
 - 9-4 ENDIF.
- 10 WHEN a RETURN ERROR or REJECT is received:
 - 10-1 Stop timer (ADT).
 - 10-2 Clear the MS's pending operation flags.
 - 10-3 Execute "Local Recovery Procedures" task (see 3.5.1).
 - 10-4 Return to the invoking process.

- 11 WHEN timer (ADT) expires:
- 11-1 Clear the MS's pending operation flags.
- 11-2 Execute "Local Recovery Procedures " task (see 3.5.1).
- 11-3 Return to the invoking process.
- 12 ENDWAIT.

4.1.6 MSC Receiving Authentication Parameters

When an MSC receives authentication parameters, the Serving MSC shall perform the following for the specified MS:

- 1 IF the DenyAccess parameter is received:
 - 1-1 IF the indicated MS is involved in a call or service operation anchored by this MSC:
 - 1-1-1 The Serving MSC may optionally discontinue the call or service operation currently in progress.
 - 1-2 ENDIF.
 - 1-3 Return to the calling task.
 - 2 ENDIF.
- 3 IF the RandomVariableSSD (RANDSSD) parameter is received (an SSD update is requested):
 - 3-1 IF the MS is involved in a call and has been handed off to another MSC:
 - 3-1-1 Include the SSDUpdateReport parameter set to indicate *SSD update not attempted*.
 - 3-1-2 Execute the "MSC Initiating an Authentication Status Report" task (see 4.5.1).
 - 3-1-3 Return to the invoking process.
 - 3-2 ELSEIF the SSD update cannot be attempted:
 - 3-2-1 Include the SSDUpdateReport parameter set to indicate *SSD update not attempted*.
 - 3-2-2 Execute the "MSC Initiating an Authentication Status Report " task (see 4.5.1).
 - 3-2-3 Return to the invoking process.
 - 3-3 ELSE (SSD update can be attempted):
 - 3-3-1 Send an SSD update order to the MS using the RandomVariableSSD (RANDSSD) value received.
 - 3-3-2 IF a Base Station Challenge order is not received from the MS:
 - 3-3-2-1 Include the SSDUpdateReport parameter set to indicate *SSD update no response*.
 - 3-3-2-2 Execute the "MSC Initiating an Authentication Status Report " task (see 4.5.1).
 - 3-3-2-3 Return to the invoking process.
 - 3-3-3 ELSE (Base Station Challenge order is received from the MS):
 - 3-3-3-1 Execute the "MSC Initiating a Base Station Challenge" task (see 4.6.1) using the value of RandomVariableBaseStation (RANDBS) provided by the MS.

1 3-3-3-2 IF the SSD update fails, the MSC shall:
2 3-3-3-2-1 Include the SSDUpdateReport parameter set to indicate *SSD update*
3 *failed*.
4 3-3-3-2-2 Execute the “MSC Initiating an Authentication Status Report ” task
5 (see 4.5.1).
6 3-3-3-2-3 Return to the invoking process.
7 3-3-3-3 ELSE (SSD update successful):
8 3-3-3-3-1 (Continue this task.)
9 3-3-3-4 ENDIF.
10 3-3-4 ENDIF.
11 3-4 ENDIF.
12 4 ENDIF.
13 5 IF the RandomVariableUniqueChallenge (RANDU) and
14 AuthenticationResponseUnique (AUTHU) parameters are received (a Unique
15 Challenge is requested):
16 5-1 IF the MS is involved in a call and has been handed off to another MSC:
17 5-1-1 Include the RandomVariableUniqueChallenge (RANDU) and
18 AuthenticationResponseUnique (AUTHU) parameters received.
19 5-1-2 Execute the “MSC Initiating an Authentication Directive Forward” task (see
20 4.2.1).
21 5-1-3 IF the Unique Challenge was not attempted:
22 5-1-3-1 Include the UniqueChallengeReport parameter set to indicate *Unique*
23 *Challenge not attempted*.
24 5-1-3-2 IF an SSD update was performed:
25 5-1-3-2-1 Include the SSDUpdateReport parameter set to indicate *SSD update*
26 *successful*.
27 5-1-3-3 ENDIF.
28 5-1-3-4 Execute the “MSC Initiating an Authentication Status Report ” (see 4.5.1)
29 task.
30 5-1-3-5 Return to the invoking process.
31 5-1-4 ELSEIF there was no response to the Unique Challenge:
32 5-1-4-1 Include the UniqueChallengeReport parameter set to indicate *Unique*
33 *Challenge no response*.
34 5-1-4-2 IF an SSD update was performed:
35 5-1-4-2-1 Include the SSDUpdateReport parameter set to indicate *SSD update*
36 *successful*.
37 5-1-4-3 ENDIF.
38 5-1-4-4 Execute the “MSC Initiating an Authentication Status Report ” (see 4.5.1)
39 task.
40 5-1-4-5 Return to the invoking process.
41 5-1-5 ELSEIF the Unique Challenge failed:
42 5-1-5-1 Include the UniqueChallengeReport parameter set to indicate *Unique*
43 *Challenge failed*.
44 5-1-5-2 IF an SSD update was performed:

5-1-5-2-1	Include the SSDUpdateReport parameter set to indicate <i>SSD update successful</i> .	1
		2
5-1-5-3	ENDIF.	3
		4
5-1-5-4	Execute the “MSC Initiating an Authentication Status Report ” (see 4.5.1) task.	5
		6
5-1-5-5	Return to the invoking process.	7
		8
5-1-6	ELSE (Unique Challenge successful):	9
5-1-6-1	(Continue this task.)	10
		11
5-1-7	ENDIF.	12
5-2	ELSEIF the Unique Challenge cannot be attempted:	13
		14
5-2-1	Include the UniqueChallengeReport parameter set to indicate <i>Unique Challenge not attempted</i> .	15
		16
5-2-2	IF an SSD update was performed:	17
5-2-2-1	Include the SSDUpdateReport parameter set to indicate <i>SSD update successful</i> .	18
		19
		20
5-2-3	ENDIF.	21
		22
5-2-4	Execute the “MSC Initiating an Authentication Status Report ” (see 4.5.1) task.	23
		24
5-2-5	Return to the invoking process.	25
		26
5-3	ELSE (Unique Challenge can be attempted):	27
		28
5-3-1	Send a Unique Challenge order to the MS using the RandomVariableUniqueChallenge (RANDU) value received.	29
		30
5-3-2	IF the MS does not respond to the Unique Challenge Order:	31
5-3-2-1	Include the UniqueChallengeReport parameter set to indicate <i>Unique Challenge no response</i> .	32
		33
5-3-2-2	IF an SSD update was performed:	34
5-3-2-2-1	Include the SSDUpdateReport parameter set to indicate <i>SSDupdate successful</i> .	35
		36
		37
5-3-2-3	ENDIF.	38
		39
5-3-2-4	Execute the “MSC Initiating an Authentication Status Report ” (see 4.5.1) task.	40
		41
5-3-2-5	Return to the invoking process.	42
		43
5-3-3	ENDIF.	44
		45
5-3-4	IF the AuthenticationResponseUnique (AUTHU) response from the MS is not equal to the AuthenticationResponseUnique (AUTHU) value received from the VLR:	46
		47
5-3-4-1	Include the UniqueChallengeReport parameter set to indicate <i>UniqueChallenge failed</i> .	48
		49
5-3-4-2	IF an SSD update was performed:	50
5-3-4-2-1	Include the SSDUpdateReport parameter set to indicate <i>SSDupdate successful</i> .	51
		52
		53
5-3-4-3	ENDIF.	54
		55
5-3-4-4	Execute the “MSC Initiating an Authentication Status Report ” (see 4.5.1) task.	56
		57
		58
		59
		60

1 5-3-4-5 Return to the invoking process.

2 5-3-5 ELSE (Unique Challenge successful):

3

4 5-3-5-1 (Continue this task.)

5 5-3-6 ENDIF.

6

7 5-4 ENDIF.

8

9 6 ENDIF.

10 7 IF a COUNT update is requested by the VLR:

11 7-1 IF the MS is involved in a call and has been handed off to another MSC:

12 7-1-1 Include the CountUpdateReport parameter set to indicate *Count Update*

13 *notattempted*.

14

15 7-1-2 IF an SSD update was performed:

16 7-1-2-1 Include the SSDUpdateReport parameter set to indicate *SSD update*

17 *successful*.

18

19 7-1-3 ENDIF.

20 7-1-4 IF a Unique Challenge was performed:

21 7-1-4-1 Include the UniqueChallengeReport parameter set to indicate *Unique*

22 *Challenge successful*.

23

24 7-1-5 ENDIF.

25 7-1-6 Execute the “MSC Initiating an Authentication Status Report ” task (see

26 4.5.1).

27

28 7-1-7 Return to the invoking process.

29 7-2 ELSEIF the COUNT update cannot be attempted:

30 7-2-1 Include the CountUpdateReport parameter set to indicate *Count Update not*

31 *attempted*.

32

33 7-2-2 IF an SSD update was performed:

34 7-2-2-1 Include the SSDUpdateReport parameter set to indicate *SSD update*

35 *successful*.

36

37 7-2-3 ENDIF.

38 7-2-4 IF a Unique Challenge was performed:

39 7-2-4-1 Include the UniqueChallengeReport parameter set to indicate *Unique*

40 *Challenge successful*.

41

42 7-2-5 ENDIF.

43 7-2-6 Execute the “MSC Initiating an Authentication Status Report ” task (see

44 4.5.1).

45

46 7-2-7 Return to the invoking process.

47 7-3 ELSE (COUNT update can be attempted):

48 7-3-1 Send a Parameter Update order to the MS.

49 7-3-2 IF the MS does not respond to the Parameter Update order:

50 7-3-2-1 Include the CountUpdateReport parameter set to indicate *Count Update*

51 *no response*.

52

53 7-3-2-2 IF an SSD update was performed:

54 7-3-2-2-1 Include the SSDUpdateReport parameter set to indicate *SSD update*

55 *successful*.

56

57

58

59

60

7-3-2-3	ENDIF.	1
7-3-2-4	IF a Unique Challenge was performed:	2
7-3-2-4-1	Include the UniqueChallengeReport parameter set to indicate <i>Unique Challenge successful</i> .	3
7-3-2-5	ENDIF.	4
7-3-2-6	Execute the “MSC Initiating an Authentication Status Report ” task (see 4.5.1).	5
7-3-2-7	Return to the invoking process.	6
7-3-3	ELSE (COUNT update successful):	7
7-3-3-1	(Continue this task.)	8
7-3-4	ENDIF.	9
7-4	ENDIF.	10
8	ENDIF.	11
9	IF an SSD update was performed OR IF a Unique Challenge was performed OR IF a COUNT update was performed:	12
9-1	IF an SSD update was performed:	13
9-1-1	Include the SSDUpdateReport parameter set to indicate <i>SSD update successful</i> .	14
9-2	ENDIF.	15
9-3	IF a Unique Challenge was performed:	16
9-3-1	Include the UniqueChallengeReport parameter set to indicate <i>Unique Challenge successful</i> .	17
9-4	ENDIF.	18
9-5	IF a COUNT update was performed:	19
9-5-1	Include the CountUpdateReport parameter set to indicate <i>COUNT update successful</i> .	20
9-6	ENDIF.	21
9-7	Execute the “MSC Initiating an Authentication Status Report ” task (see 4.5.1).	22
9-8	Return to the invoking process.	23
10	ELSE:	24
10-1	Return to the invoking process.	25
11	ENDIF.	26

4.2 AUTHENTICATION DIRECTIVE FORWARD

The Anchor MSC shall use the Authentication Directive Forward operation to initiate a Unique Challenge for an MS that is engaged in a call and has been handed off to another MSC.

4.2.1 Anchor MSC Initiating an Authentication Directive Forward

When the Anchor MSC receives a request to perform a Unique Challenge for an MS that is engaged in a call and has been handed off to another MSC, the Anchor MSC shall perform the following:

- 1 Include the MobileIdentificationNumber parameter set to the specified MS's MIN.
- 2 Include the RandomVariableUniqueChallenge (RANDU) and AuthenticationResponseUnique (AUTHU) parameters specified by the calling task.
- 3 Send an AuthenticationDirectiveForward INVOKE toward the MSC serving the MS.
- 4 Start the Authentication Directive Forward Timer (ADFT).
- 5 WAIT for an Authentication Directive Forward response.
- 6 WHEN a RETURN RESULT is received:
 - 6-1 Stop timer (ADFT).
 - 6-2 IF the message can be processed:
 - 6-2-1 CASE UniqueChallengeReport OF:
 - 6-2-2 *Unique Challenge successful:*
 - 6-2-2-1 Return to the calling task with an indication of *successful*.
 - 6-2-3 *Unique Challenge no response:*
 - 6-2-3-1 Return to the calling task with an indication of *no response*.
 - 6-2-4 *Unique Challenge failed:*
 - 6-2-4-1 Return to the calling task with an indication of *failed*.
 - 6-2-5 *DEFAULT:*
 - 6-2-5-1 Return to the calling task with an indication of *not attempted*.
 - 6-2-6 ENDCASE.
 - 6-3 ELSE (the message cannot be processed):
 - 6-3-1 Execute the "Local Recovery Procedures" task (see 3.5.1).
 - 6-3-2 Return to the invoking process with an indication of *not attempted*.
 - 6-4 ENDIF.
 - 7 WHEN a RETURN ERROR or REJECT is received:
 - 7-1 Stop timer (ADFT).
 - 7-2 IF a RETURN ERROR is received with the Parameter Error indicating *OperationNotSupported*:
 - 7-2-1 Return to the invoking process with an indication of *not attempted*.
 - 7-3 ELSE:
 - 7-3-1 Execute the "Local Recovery Procedures" task (see 3.5.1).
 - 7-3-2 Return to the invoking process with an indication of *not attempted*.
 - 7-4 ENDIF.
 - 8 WHEN a FacilitiesRelease INVOKE is received for the inter-MSC trunk for the call:
 - 8-1 Stop timer (ADFT).
 - 8-2 Return to the invoking process with an indication of *not attempted*.
 - 9 WHEN the Timer (ADFT) expires:
 - 9-1 Execute recovery procedures for the Anchor MSC.

- 9-2 Return to the invoking process with an indication of *not attempted*.
 10 ENDWAIT.

4.2.2 Serving MSC Receiving an AuthenticationDirectiveForward INVOKE

When the Serving MSC receives an AuthenticationDirectiveForward INVOKE message for an MS, it shall perform the following:

- 1 IF the Serving MSC is not capable of performing the Unique Challenge:
 - 1-1 Send a RETURN ERROR indicating *OperationNotSupported* toward the Anchor MSC.
- 2 ELSEIF the Unique Challenge cannot be attempted:
 - 2-1 Include the UniqueChallengeReport parameter set to indicate *Unique Challenge not attempted*.
 - 2-2 Send a RETURN RESULT.
- 3 ELSE (the Unique Challenge can be performed):
 - 3-1 Order the MS to a Unique Challenge the RandomVariableUniqueChallenge (RANDU) value received from the Anchor MSC.
 - 3-2 IF the MS does not respond to the Unique Challenge Order:
 - 3-2-1 Include the UniqueChallengeReport parameter set to indicate *Unique Challenge no response*.
 - 3-2-2 Send a RETURN RESULT.
 - 3-3 ELSEIF the AuthenticationResponseUnique (AUTHU) response from the MS is not equal to the AuthenticationResponseUnique (AUTHU) value received from the Anchor MSC:
 - 3-3-1 Include the UniqueChallengeReport parameter set to indicate *Unique Challenge failed*.
 - 3-3-2 Send a RETURN RESULT.
 - 3-4 ELSE (Unique Challenge successful):
 - 3-4-1 Include the UniqueChallengeReport parameter set to indicate Unique Challenge successful.
 - 3-4-2 Send a RETURN RESULT.
 - 3-5 ENDIF.
- 4 ENDIF.
- 5 Exit this task.

Table 4 Serving MSC AuthenticationDirectiveForward Response

Problem Detection and Recommended Response from a Serving or Tandem MSC to a Tandem or Anchor MSC											
PROBLEM DEFINITION	1	2	3	4	5	6	7	8	9	Notes	
RETURN ERROR Error Code											
<i>UnrecognizedMIN</i>							X				
<i>UnrecognizedESN</i>								X			
<i>MIN/HLRMismatch</i>											a
<i>OperationSequenceProblem</i>						X					
<i>ResourceShortage</i>		X									
<i>OperationNotSupported</i>	X										b
<i>TrunkUnavailable</i>											a
<i>ParameterError</i>				X							d
<i>SystemFailure</i>			X								
<i>UnrecognizedParameterValue</i>					X						d
<i>FeatureInactive</i>											a
<i>MissingParameter</i>									X		d
RETURN RESULT											c

Problem Detections:

1. The requested MAP operation is recognized, but not supported by the receiving Serving or Tandem MSC or the requesting functional entity is not authorized.
2. A required Serving or Tandem MSC resource (e.g., internal memory record, MSC is fully occupied) is temporarily not available (e.g., congestion).
3. A required resource (e.g., data base access, functional entity) is not presently accessible due to a failure. Human intervention may be required for resolution.
4. A received parameter has an encoding problem (e.g., the received MobileIdentificationNumber digit values do not meet the BCD specification).
5. A received parameter value is unrecognized or has nonstandard values (e.g., the supplied InterMSCCircuitID is not recognized, the supplied RandomVariableUniqueChallenge (RANDU) does not meet the expected specification).
6. The supplied InterMSCCircuitID parameter value is valid, but this trunk circuit is presently not active with a call.
7. The supplied MobileIdentificationNumber parameter does not match the MIN of the call on the supplied InterMSCCircuitID trunk circuit.
8. The supplied ElectronicSerialNumber parameter does not match the ESN of the call on the supplied InterMSCCircuitID trunk circuit.
9. An optional parameter required for this operation is missing (e.g., RandomVariableUniqueChallenge (RANDU)).

Notes:

- a. This Error Code is not an appropriate MSC response to an AuthenticationDirectiveForward transaction.
- b. It is recommended that a Serving or Tandem MSC supports AuthenticationDirectiveForward transactions.
- c. Only RETURN RESULT operations needing clarification have been included.
- d. Include the *Parameter Identifier* in question as the FaultyParameter parameter.

4.2.3 Tandem MSC Receiving an Authentication Directive Forward

When a Tandem MSC receives an AuthenticationDirectiveForward INVOKE, it shall perform the following:

- 1 IF the received message can be processed:
 - 1-1 Replace the received the InterMSCCircuitID parameter value with the ID of the trunk used in the direction toward the Serving MSC for the call.
 - 1-2 Relay the other received parameters.
 - 1-3 Send an AuthenticationDirectiveForward INVOKE toward the Serving MSC.
 - 1-4 Start the Authentication Directive Forward Timer (ADFT).
 - 1-5 WAIT for an Authentication Directive Forward response.
 - 1-6 WHEN a RETURN RESULT is received:
 - 1-6-1 Stop the timer (ADFT).
 - 1-6-2 Relay the received parameters.
 - 1-6-3 Send a RETURN RESULT toward the Anchor MSC.
 - 1-7 WHEN a RETURN ERROR is received:
 - 1-7-1 Stop the timer (ADFT).
 - 1-7-2 Relay the Error Code and the received FaultyParameter parameter.
 - 1-7-3 Send a RETURN ERROR toward the Serving MSC.
 - 1-7-4 Execute the “Local Recovery Procedures” task (see 3.5.1).
 - 1-8 WHEN a REJECT is received:
 - 1-8-1 Send a RETURN ERROR toward the Anchor MSC with the Error Code indicating *SystemFailure*.
 - 1-8-2 Execute the “Local Recovery Procedures ” task (see 3.5.1).
 - 1-9 WHEN the timer (ADFT) expires:
 - 1-9-1 (The initiating functional entity timer should have expired, so no notification is necessary.)
 - 1-9-2 Execute the “Local Recovery Procedures ” task (see 3.5.1).
 - 1-10 ENDWAIT.
- 2 ELSE (the received message cannot be processed):
 - 2-1 Send a RETURN ERROR with the proper Error Code value toward the Anchor MSC.
 - 2-2 Execute the “Local Recovery Procedures ” task (see 3.5.1).
- 3 ENDIF.
- 4 Exit this task.

4.3 AUTHENTICATION FAILURE REPORT

4.3.1 MSC Initiating an Authentication Failure Report

When an MSC determines that an Authentication Failure Report is necessary, it shall perform the following:

- 1 Include the ReportType parameter set to the value indicated by the calling task.
 - 2 Include the SystemAccessType parameter indicating the type of access triggering this report (e.g., *Autonomous registration, Power down registration, Call origination, Page response, Flash request*).
 - 3 Include the SystemCapabilities (SYSCAP) parameter indicating whether authentication parameters were requested for this system access.
 - 4 Include the MSCID parameter set to the MSC's identity information.
 - 5 Include the SenderIdentificationNumber set to the identification number of the sending functional entity.
 - 6 Send an AuthenticationFailureReport INVOKE to the MSC's associated VLR.
 - 7 Start the Authentication Failure Report Timer (AFRT).
 - 8 WAIT for an Authentication Failure Report response:
 - 9 WHEN a RETURN RESULT is received:
 - 9-1 Stop timer (AFRT).
 - 9-2 IF the message can be processed:
 - 9-2-1 IF the TerminalType (TERMTYP) parameter is not received (i.e., the AC is using *TSB51* authentication procedures):
 - 9-2-1-1 IF *TSB51* operation is supported:
 - 9-2-1-1-1 Execute *TSB51* procedures for SecurityStatusReport (refer to *TIA/EIA TSB51*).
 - 9-2-1-1-2 Return to the invoking process.
 - 9-2-1-2 ELSE (*TSB51* operation is not supported):
 - 9-2-1-2-1 Execute the "Local Recovery Procedures" task (see 3.5.1).
 - 9-2-1-2-2 Return to the invoking process.
 - 9-2-1-3 ENDIF.
 - 9-2-2 ELSE (TerminalType (TERMTYP) parameter is received, i.e., the AC is using *IS-41-C* authentication procedures):
 - 9-2-2-1 Execute the "MSC Receiving Authentication Parameters" task (see 4.1.6) using the parameters received.
 - 9-2-2-2 Return to the invoking process.
 - 9-2-3 ENDIF.
 - 9-3 ELSE (the message cannot be processed):
 - 9-3-1 Execute the "Local Recovery Procedures" task (see 3.5.1).
 - 9-3-2 Return to the invoking process.
 - 9-4 ENDIF.
- 10 WHEN a RETURN ERROR or REJECT is received:

- 10-1 Stop timer (AFRT).
- 10-2 Execute the “Local Recovery Procedures ” task (see 3.5.1).
- 10-3 Return to the invoking process.
- 11 WHEN timer (AFRT) expires:
 - 11-1 Execute the “Local Recovery Procedures ” task (see 3.5.1).
 - 11-2 Return to the invoking process.
- 12 ENDWAIT.

4.3.2 VLR Receiving AuthenticationFailureReport INVOKE

When a VLR receives an AuthenticationFailureReport INVOKE, it shall perform the following:

- 1 IF the received message can be processed:
 - 1-1 Include the SenderIdentificationNumber set to the identification number of the sending functional entity.
 - 1-2 Include the SystemCapabilities parameter set by the VLR.
 - 1-3 Relay all other received parameters.
 - 1-4 Send an AuthenticationFailureReport INVOKE to the HLR associated with the MS.
 - 1-5 Start the Authentication Failure Report Timer (AFRT).
 - 1-6 WAIT for an Authentication Failure Report response:
 - 1-7 WHEN a RETURN RESULT is received:
 - 1-7-1 Stop timer (AFRT).
 - 1-7-2 IF the message can be processed:
 - 1-7-2-1 IF the TerminalType (TERMTYP) parameter is not received (i.e., the AC is using *TSB51* authentication procedures):
 - 1-7-2-1-1 IF *TSB51* operation is supported:
 - 1-7-2-1-1-1 Execute *TSB51* procedures for SecurityStatusReport (refer to *TIA/EIA TSB51*).
 - 1-7-2-1-1-2 Exit this task.
 - 1-7-2-1-2 ELSE (*TSB51* operation is not supported):
 - 1-7-2-1-2-1 Execute the “Local Recovery Procedures” task (see 3.5.1).
 - 1-7-2-1-2-2 Exit this task.
 - 1-7-2-1-3 ENDIF.
 - 1-7-2-2 ELSE (the TerminalType (TERMTYP) parameter is received, i.e., the AC is using *IS-41-C* authentication procedures):
 - 1-7-2-2-1 IF the DenyAccess parameter is received:
 - 1-7-2-2-1-1 Relay the DenyAccess parameter.
 - 1-7-2-2-2 ENDIF.
 - 1-7-2-2-3 IF the SSDNotShared (NOSSD) parameter is received:
 - 1-7-2-2-3-1 Remove the MS’s current SharedSecretData (SSD) and AuthenticationAlgorithmVersion (AAV) from the VLR’s database.

1 1-7-2-2-4 ENDIF.

2 1-7-2-2-5 IF the RandomVariableSSD (RANDSSD) is received:

3

4 1-7-2-2-5-1 IF SharedSecretData (SSD) is shared:

5 1-7-2-2-5-1-1 Remove the MS's current SharedSecretData (SSD) and

6 AuthenticationAlgorithmVersion (AAV) from the VLR's

7 database.

8

9 1-7-2-2-5-2 ENDIF.

10 1-7-2-2-5-3 Relay the received RandomVariableSSD (RANDSSD)

11 parameter.

12

13 1-7-2-2-5-4 Mark the MS *pending SSD update*.

14 1-7-2-2-5-5 IF the SharedSecretData (SSD) parameter is received:

15 1-7-2-2-5-5-1 IF the AuthenticationAlgorithmVersion (AAV) parameter

16 is received:

17 1-7-2-2-5-5-1-1 Store the AuthenticationAlgorithmVersion (AAV)

18 value.

19

20 1-7-2-2-5-5-2 ENDIF.

21 1-7-2-2-5-5-3 IF the CallHistoryCount (COUNT) parameter is received:

22 Store the pending CallHistoryCount (COUNT) value.

23 1-7-2-2-5-5-3-1

24 1-7-2-2-5-5-4 ENDIF.

25

26 1-7-2-2-5-5-5 Store the pending SSD value.

27 1-7-2-2-5-5-6 Select a RandomVariableUniqueChallenge (RANDU) and

28 execute CAVE using the value of the pending SSD to

29 produce an AuthenticationResponseUnique (AUTHU).

30

31 1-7-2-2-5-5-7 Include the RandomVariableUniqueChallenge (RANDU)

32 and AuthenticationResponseUnique (AUTHU)

33 parameters.

34

35 1-7-2-2-5-5-8 Mark the MS *pending Unique Challenge*.

36 1-7-2-2-5-6 ELSE (the SharedSecretData (SSD) was not received):

37 1-7-2-2-5-6-1 Relay the RandomVariableUniqueChallenge (RANDU)

38 parameter.

39

40 1-7-2-2-5-6-2 Relay the AuthenticationResponseUnique (AUTHU)

41 parameter.

42

43 1-7-2-2-5-6-3 Mark the MS *pending Unique Challenge*.

44 1-7-2-2-5-7 ENDIF.

45 1-7-2-2-6 ELSE (the RandomVariableSSD (RANDSSD) was not received):

46 1-7-2-2-6-1 IF the SharedSecretData (SSD) parameter is received:

47 Store the SharedSecretData (SSD) value.

48 1-7-2-2-6-1-1

49 1-7-2-2-6-1-2 IF the AuthenticationAlgorithmVersion (AAV) parameter

50 is received:

51 1-7-2-2-6-1-2-1 Store the AuthenticationAlgorithmVersion (AAV)

52 value.

53

54 1-7-2-2-6-1-3 ENDIF.

55 1-7-2-2-6-1-4 IF the CallHistoryCount (COUNT) parameter is received:

56 Store the received CallHistoryCount (COUNT) value.

57 1-7-2-2-6-1-4-1

58

59

60

1-7-2-2-6-1-5	ENDIF.	1
1-7-2-2-6-2	ENDIF.	2
1-7-2-2-6-3	IF the RandomVariableUniqueChallenge (RANDU) parameter is received:	3
1-7-2-2-6-3-1	Relay the RandomVariableUniqueChallenge (RANDU) parameter.	4
1-7-2-2-6-3-2	Relay the AuthenticationResponseUnique (AUTHU) parameter.	5
1-7-2-2-6-3-3	Mark the MS <i>pending Unique Challenge</i> .	6
1-7-2-2-6-4	ENDIF.	7
1-7-2-2-7	ENDIF.	8
1-7-2-2-8	IF the UpdateCount (UPDCOUNT) parameter is received:	9
1-7-2-2-8-1	Relay the received UpdateCount (UPDCOUNT) parameter.	10
1-7-2-2-8-2	Mark the MS <i>pending COUNT update</i> .	11
1-7-2-2-9	ENDIF.	12
1-7-2-2-10	Send an AuthenticationFailureReport RETURN RESULT to the requesting MSC.	13
1-7-2-2-11	IF the MS is marked <i>pending SSD update</i> , OR IF the MS is marked <i>pending Unique Challenge</i> , OR IF the MS is marked <i>pending COUNT update</i> :	14
1-7-2-2-11-1	Execute the “VLR Awaiting AuthenticationStatusReport INVOKE” task (see 4.5.2).	15
1-7-2-2-12	ENDIF.	16
1-7-2-2-13	Exit this task.	17
1-7-2-3	ENDIF.	18
1-7-3	ELSE (the message cannot be processed):	19
1-7-3-1	Send a RETURN ERROR to the requesting MSC.	20
1-7-3-2	Exit this task.	21
1-7-4	ENDIF.	22
1-8	ENDIF.	23
1-9	WHEN a RETURN ERROR or REJECT is received:	24
1-9-1	Stop timer (AFRT).	25
1-9-2	CASE Error Code OF:	26
1-9-3	<i>ParameterError</i> :	27
1-9-3-1	IF the parameter was originated from the initiating functional entity:	28
1-9-3-1-1	Send a RETURN ERROR with Error Code set to indicate <i>ParameterError</i> .	29
1-9-3-2	ELSE:	30
1-9-3-2-1	Send a RETURN ERROR with Error Code set to indicate <i>SystemFailure</i> .	31
1-9-3-3	ENDIF.	32
1-9-4	<i>DEFAULT</i> :	33
1-9-4-1	Send a RETURN ERROR with Error Code set to indicate <i>SystemFailure</i> .	34
		35
		36
		37
		38
		39
		40
		41
		42
		43
		44
		45
		46
		47
		48
		49
		50
		51
		52
		53
		54
		55
		56
		57
		58
		59
		60

- 1 1-9-5 ENDCASE.
 2
 3 1-9-6 Execute "Local Recovery Procedures" task (see 3.5.1).
 4 1-9-7 Exit this task.
 5 1-10 WHEN timer (AFRT) expires:
 6
 7 1-10-1 Send a RETURN ERROR with Error Code set to indicate *SystemFailure*.
 8 1-10-2 Execute "Local Recovery Procedures" task (see 3.5.1).
 9 1-10-3 Exit this task.
 10
 11 1-11 ENDWAIT.
 12
 13 2 ELSE (the message cannot be processed):
 14 2-1 Send a RETURN ERROR to the requesting MSC.
 15 3 ENDIF.
 16
 17 4 Exit this task.

18
 19 **Table 5 VLR AuthenticationFailureReport Response**

20
 21
 22

Problem Detection and Recommended Response from VLR to MSC											
PROBLEM DEFINITION	1	2	3	4	5	6	7	8	9	10	Notes
RETURN ERROR Error Code											
<i>UnrecognizedMIN</i>											a
<i>UnrecognizedESN</i>											a
<i>MIN/HLRMismatch</i>						X					e
<i>OperationSequenceProblem</i>											a
<i>ResourceShortage</i>		X									e
<i>OperationNotSupported</i>	X										b, e
<i>TrunkUnavailable</i>											a
<i>ParameterError</i>				X							d
<i>SystemFailure</i>			X								e
<i>UnrecognizedParameterValue</i>					X						d, e
<i>FeatureInactive</i>											a
<i>MissingParameter</i>							X				d, e
RETURN RESULT Deny Access								X	X	X	c

23
 24
 25
 26
 27
 28
 29
 30
 31
 32
 33
 34
 35
 36
 37
 38
 39
 40
 41

42
 43 **Problem Detections:**

- 44
 45
 46
 47
 48
 49
 50
 51
 52
 53
 54
 55
 56
 57
 58
 59
 60
1. The requested MAP operation is recognized, but not supported by the receiving AC (HLR/VLR) or the requesting functional entity is not authorized.
 2. A required AC (HLR) resource (e.g., internal memory record, AC (HLR/VLR) is fully occupied) is temporarily not available (e.g., congestion).
 3. A required resource (e.g., data base access, functional entity) is not presently accessible due to a failure. Human intervention may be required for resolution.
 4. A supplied parameter value has an encoding problem (e.g., the supplied MobileIdentificationNumber parameter or Digits (Dialed) parameter digit values do not meet the expected BCD specification)).
 5. A supplied parameter value is unrecognized or has nonstandard values (e.g., *Not used*, SystemCapabilities (SYSCAP) parameter indicated authentication is not supported (AUTH is 0) but this AuthenticationFailureReport was received).
 6. The supplied MobileIdentificationNumber parameter's AC (HLR) responded that the MIN is not in the AC (HLR)'s range of MIN's or directory numbers (suspect routing error).

7. An optional parameter required by the AC (HLR) was expected, but not received (e.g., a SSD update process was in-progress and a ReportType set to *SSD update successful* was received, but the expected second ReportType parameter indicating the CallHistoryCount's (COUNT's) incrementing status (e.g., *COUNT update successful*, *COUNT mismatch*, *Count update no response* etc.) was not received).
8. The supplied MobileIdentificationNumber parameter's AC (HLR) responded that the MIN is within the range of the AC (HLR), but the MIN is not presently assigned to a subscriber. DenyAccess parameter value is *Unspecified*.
9. An AC (HLR) record exists for the supplied MobileIdentificationNumber parameter, but the supplied ElectronicSerialNumber parameter does not match the ESN in the MIN's record. DenyAccess parameter value is *Unspecified*.
10. An AC (HLR) record exists for the supplied MobileIdentificationNumber parameter, but the MIN is either a DelinquentAccount, StolenUnit, DuplicateUnit or Unspecified. DenyAccess parameter value is *Unspecified*.

Notes:

- a. This Error Code is not an appropriate AC (HLR) response to a AuthenticationFailureReport transaction.
- b. It is recommended that an AC (HLR) supports AuthenticationFailureReport transactions.
- c. Only RETURN RESULT operations needing clarification have been included.
- d. Include the *Parameter Identifier* in question as the FaultyParameter parameter.
- e. This response may have been originated by the AC (HLR).

4.3.3 HLR Receiving AuthenticationFailureReport INVOKE

When an HLR receives an AuthenticationFailureReport INVOKE, it shall perform the following:

- 1 IF the received message can be processed:
 - 1-1 Relay all received parameters.
 - 1-2 Start the Authentication Failure Report Timer (AFRT).
 - 1-3 Send an AuthenticationFailureReport INVOKE to the AC associated with the MS.
 - 1-4 WAIT for an Authentication Failure Report response:
 - 1-5 WHEN a RETURN RESULT is received:
 - 1-5-1 Stop timer (AFRT).
 - 1-5-2 IF the message can be processed:
 - 1-5-2-1 Relay all received parameters.
 - 1-5-2-2 Send a RETURN RESULT to the requesting VLR.
 - 1-5-3 ELSE:
 - 1-5-3-1 Send a RETURN ERROR with the Error Code set to indicate *SystemFailure* to the requesting VLR.
 - 1-5-4 ENDIF.
 - 1-6 WHEN a RETURN ERROR or REJECT is received:
 - 1-6-1 Stop timer (AFRT).
 - 1-6-2 CASE Error Code OF:
 - 1-6-3 *ParameterError*:
 - 1-6-3-1 IF the parameter was originated from the initiating functional entity:

- 1-6-3-1-1 Send a RETURN ERROR with Error Code set to indicate *ParameterError*.
- 1-6-3-2 ELSE:
- 1-6-3-2-1 Send a RETURN ERROR with Error Code set to indicate *SystemFailure*.
- 1-6-3-3 ENDIF.
- 1-6-4 DEFAULT:
- 1-6-4-1 Send a RETURN ERROR with Error Code set to indicate *SystemFailure*.
- 1-6-5 ENDCASE.
- 1-6-6 Execute “Local Recovery Procedures” task (see 3.5.1).
- 1-6-7 Exit this task.
- 1-7 WHEN timer (AFRT) expires:
- 1-7-1 Send a RETURN ERROR with the Error Code set to indicate *SystemFailure*.
- 1-7-2 Execute “Local Recovery Procedures ” task (see 3.5.1).
- 1-7-3 Exit this task.
- 1-8 ENDWAIT.
- 2 ELSE (the received message cannot be processed):
- 2-1 Send a RETURN ERROR with the proper Error Code value (see the following table) to the requesting VLR.
- 3 ENDIF.
- 4 Exit this task.

Table 6 HLR AuthenticationFailureReport Response

Problem Detection and Recommended Response from HLR to VLR											
PROBLEM DEFINITION	1	2	3	4	5	6	7	8	9	10	Notes
RETURN ERROR Error Code											
<i>UnrecognizedMIN</i>											a
<i>UnrecognizedESN</i>											a
<i>MIN/HLRMismatch</i>						X					e
<i>OperationSequenceProblem</i>											a
<i>ResourceShortage</i>		X									e
<i>OperationNotSupported</i>	X										b, e
<i>TrunkUnavailable</i>											a
<i>ParameterError</i>				X							d
<i>SystemFailure</i>			X								e
<i>UnrecognizedParameterValue</i>					X						d, e
<i>FeatureInactive</i>											a
<i>MissingParameter</i>							X				d, e
RETURN RESULT Deny Access								X	X	X	c

Problem Detections:

- The requested MAP operation is recognized, but not supported by the receiving AC (HLR/VLR) or the requesting functional entity is not authorized.

2. A required AC (HLR) resource (internal memory record, AC (HLR/VLR) is fully occupied) is temporarily not available (e.g., congestion).
3. A required resource (e.g., data base access, functional entity) is not presently accessible due to a failure. Human intervention may be required for resolution.
4. A supplied parameter value has an encoding problem (e.g., the supplied MobileIdentificationNumber parameter or Digits (Dialed) parameter digit values do not meet the expected BCD specification)).
5. A supplied parameter value is unrecognized or has nonstandard values (e.g., *Not used*, SystemCapabilities (SYSCAP) parameter indicated authentication is not supported (AUTH is 0) but this AuthenticationFailureReport was received).
6. The supplied MobileIdentificationNumber parameter's AC (HLR) responded that the MIN is not in the AC (HLR)'s range of MIN's or directory numbers (suspect routing error).
7. An optional parameter required by the AC (HLR) was expected, but not received (e.g., a SSD update process was in-progress and a ReportType set to *SSD update successful* was received, but the expected second ReportType parameter indicating the CallHistoryCount's (COUNT's) incrementing status (e.g., *COUNT update successful*, *COUNT mismatch*, *Count update no response* etc.) was not received).
8. The supplied MobileIdentificationNumber parameter's AC (HLR) responded that the MIN is within the range of the AC (HLR), but the MIN is not presently assigned to a subscriber. DenyAccess parameter value is *Unspecified*.
9. An AC (HLR) record exists for the supplied MobileIdentificationNumber parameter, but the supplied ElectronicSerialNumber parameter does not match the ESN in the MIN's record. DenyAccess parameter value is *Unspecified*.
10. An AC (HLR) record exists for the supplied MobileIdentificationNumber parameter, but the MIN is either a DelinquentAccount, StolenUnit, DuplicateUnit or Unspecified. DenyAccess parameter value is *Unspecified*.

Notes:

- a. This Error Code is not an appropriate AC (HLR) response to a AuthenticationFailureReport transaction.
- b. It is recommended that an AC (HLR) supports AuthenticationFailureReport transactions.
- c. Only RETURN RESULT operations needing clarification have been included.
- d. Include the *Parameter Identifier* in question as the FaultyParameter parameter.
- e. This response may have been originated by the AC (HLR).

4.3.4 AC Receiving AuthenticationFailureReport INVOKE

When an AC receives an AuthenticationFailureReport INVOKE, it shall perform the following:

- 1 IF the received message can be processed:
 - 1-1 IF the MSCID parameter is not received (the VLR is *TSB51* compliant):
 - 1-1-1 IF *TSB51* operation is supported:
 - 1-1-1-1 Execute *TSB51* procedures for the SecurityStatusReport (refer to *TIA/EIA TSB51*).
 - 1-1-2 ELSE (*TSB51* operation is not supported):
 - 1-1-2-1 Send a RETURN ERROR with the error code set to *OperationNotSupported*.
 - 1-1-3 ENDIF.
 - 1-1-4 Exit this task.
 - 1-2 ELSE (the MSCID parameter is received (the VLR is not *TSB51* compliant):

1 1-2-1 IF the ReportType parameter indicates that an authentication failure has been
2 detected:
3
4 1-2-1-1 Execute recovery procedures according to the AC's internal algorithm.
5 1-2-2 ENDIF.
6
7 1-2-3 IF service shall be denied:
8 1-2-3-1 Include the DenyAccess parameter.
9 1-2-3-2 Send a RETURN RESULT.
10 1-2-3-3 Exit this task.
11
12 1-2-4 ENDIF.
13 1-2-5 IF SharedSecretData (SSD) presently shared with the VLR shall be discarded:
14 1-2-5-1 Include the SSDNotShared (NOSSD) parameter.
15 1-2-6 ENDIF.
16
17 1-2-7 IF an SSD update shall be initiated:
18 1-2-7-1 Select a RandomVariableSSD (RANDSSD) value and execute CAVE
19 using the value of the MS's A-key recorded in the AC's database to
20 produce a pending SSD.
21
22 1-2-7-2 Include the RandomVariableSSD (RANDSSD) parameter.
23 1-2-7-3 Mark the MS *pending SSD update*.
24 1-2-7-4 IF AC administrative procedures indicate that the pending SSD shall be
25 shared with the VLR for the SSD update operation:
26
27 1-2-7-4-1 IF the VLR's SystemCapabilities (SYSCAP) indicates that the VLR
28 is able to execute the CAVE algorithm:
29
30 1-2-7-4-1-1 Include the SharedSecretData (SSD) parameter set to the
31 pending SSD value.
32
33 1-2-7-4-1-2 IF the AuthenticationAlgorithmVersion (AAV) parameter for
34 this MS is different than the default value:
35 1-2-7-4-1-2-1 Include the AuthenticationAlgorithmVersion (AAV)
36 parameter.
37
38 1-2-7-4-1-3 ENDIF.
39 1-2-7-4-2 ENDIF.
40 1-2-7-5 ELSE (the pending SSD is not shared):
41 1-2-7-5-1 Select a RandomVariableUniqueChallenge (RANDU) and execute
42 CAVE using the value of the pending SSD to produce an
43 AuthenticationResponseUnique (AUTHU).
44
45 1-2-7-5-2 Include the RandomVariableUniqueChallenge (RANDU) and
46 AuthenticationResponseUnique (AUTHU) parameters.
47
48 1-2-7-5-3 Mark the MS *pending Unique Challenge*.
49 1-2-7-6 ENDIF.
50 1-2-8 ELSE (SSD update not initiated):
51 1-2-8-1 IF the SharedSecretData (SSD) shall be shared with the VLR:
52 1-2-8-1-1 IF the VLR's SystemCapabilities (SYSCAP) indicates the VLR is
53 capable of executing the CAVE algorithm:
54 1-2-8-1-1-1 Include the SharedSecretData (SSD) and
55 CallHistoryCount(COUNT) parameters.
56
57
58
59
60

1-2-8-1-1-2	IF the AuthenticationAlgorithmVersion (AAV) parameter for this MS is different than the default value:	1
		2
		3
1-2-8-1-1-2-1	Include the AuthenticationAlgorithmVersion (AAV) parameter.	4
		5
1-2-8-1-1-3	ENDIF.	6
		7
1-2-8-1-2	ENDIF.	8
		9
1-2-8-2	ENDIF.	10
1-2-8-3	IF a Unique Challenge shall be initiated:	11
		12
1-2-8-3-1	Select a RandomVariableUniqueChallenge (RANDU) and execute CAVE using the value of the MS's SharedSecretData (SSD) recorded in the AC's database to produce an AuthenticationResponseUnique (AUTHU).	13
		14
		15
1-2-8-3-2	Include the RandomVariableUniqueChallenge (RANDU) and AuthenticationResponseUnique (AUTHU) parameters.	16
		17
		18
1-2-8-3-3	Mark the MS <i>pending Unique Challenge</i> .	19
		20
1-2-8-4	ENDIF.	21
		22
1-2-9	ENDIF.	23
		24
1-2-10	IF a COUNT update shall be initiated:	25
		26
1-2-10-1	Include the UpdateCount (UPDCOUNT) parameter.	27
		28
1-2-10-2	Mark the MS <i>pending COUNT update</i> .	29
		30
1-2-11	ENDIF.	31
		32
1-2-12	Send a RETURN RESULT to the requesting HLR.	33
		34
1-2-13	IF the MS is marked <i>pending SSD update</i> , OR IF the MS is marked <i>pendingUnique Challenge</i> , OR IF the MS is marked <i>pending COUNT update</i> :	35
		36
1-2-13-1	Execute the "AC Awaiting AuthenticationStatusReport INVOKE" task (see 4.5.4).	37
		38
1-2-14	ENDIF.	39
		40
1-2-15	Exit this task.	41
		42
1-3	ENDIF.	43
		44
2	ELSE (the message cannot be processed):	45
		46
2-1	Send a RETURN ERROR to the requesting HLR.	47
		48
3	ENDIF.	49
		50
4	Exit this task.	51
		52
		53
		54
		55
		56
		57
		58
		59
		60

Table 7 AC AuthenticationFailureReport Response

Problem Detection and Recommended Response from AC to HLR											
PROBLEM DEFINITION	1	2	3	4	5	6	7	8	9	10	Notes
RETURN ERROR Error Code											
<i>UnrecognizedMIN</i>											a
<i>UnrecognizedESN</i>											a
<i>MIN/HLRMismatch</i>						X					e
<i>OperationSequenceProblem</i>											a
<i>ResourceShortage</i>		X									e
<i>OperationNotSupported</i>	X										b, e
<i>TrunkUnavailable</i>											a
<i>ParameterError</i>				X							a
<i>SystemFailure</i>			X								e
<i>UnrecognizedParameterValue</i>					X						d, e
<i>FeatureInactive</i>											a
<i>MissingParameter</i>							X				d, e
RETURN RESULT Deny Access								X	X	X	c

Problem Detections:

1. The requested MAP operation is recognized, but not supported by the receiving AC (HLR/VLR) or the requesting functional entity is not authorized.
2. A required AC (HLR) resource (e.g., internal memory record, AC (HLR/VLR) is fully occupied) is temporarily not available (e.g., congestion).
3. A required resource (e.g., data base access, functional entity) is not presently accessible due to a failure. Human intervention may be required for resolution.
4. A supplied parameter value has an encoding problem (e.g., the supplied MobileIdentificationNumber parameter or Digits (Dialed) parameter digit values do not meet the expected BCD specification)).
5. A supplied parameter value is unrecognized or has nonstandard values (e.g., *Not used*, SystemCapabilities (SYSCAP) parameter indicated authentication is not supported (AUTH is 0) but this AuthenticationFailureReport was received).
6. The supplied MIN's AC (HLR) responded that the MobileIdentificationNumber parameter is not in the AC (HLR)'s range of MIN's or directory numbers (suspect routing error).
7. An optional parameter required by the AC (HLR) was expected, but not received (e.g., a SSD update process was in-progress and a ReportType set to *SSD update successful* was received, but the expected second ReportType parameter indicating the CallHistoryCount's (COUNT's) incrementing status (e.g., *COUNT update successful*, *COUNT mismatch*, *Count update noresponse* etc.) was not received).
8. The supplied MIN's AC (HLR) responded that the MobileIdentificationNumber parameter is within the range of the AC (HLR), but the MIN is not presently assigned to a subscriber. DenyAccess parameter value is *Unspecified*.
9. An AC (HLR) record exists for the supplied MobileIdentificationNumber parameter, but the supplied ElectronicSerialNumber parameter does not match the ESN in the MIN's record. DenyAccess parameter value is *Unspecified*.
10. An AC (HLR) record exists for the supplied MobileIdentificationNumber parameter, but the MIN is either a DelinquentAccount, StolenUnit, DuplicateUnit or Unspecified. DenyAccess parameter value is *Unspecified*.

Notes:

- a. This Error Code is not an appropriate AC (HLR) response to a AuthenticationFailureReport transaction.
- b. It is recommended that an AC (HLR) supports AuthenticationFailureReport transactions.
- c. Only RETURN RESULT operations needing clarification have been included.
- d. Include the *Parameter Identifier* in question as the FaultyParameter parameter.
- e. This response may have been originated by the AC (HLR).

4.3.5 VLR Initiating an Authentication Failure Report

When a VLR determines that an Authentication Failure Report is necessary, it shall perform the following:

- 1 Include the ReportType parameter set to the value indicated by the calling task.
- 2 Include the SystemCapabilities (SYSCAP) parameter indicating whether the VLR is able to execute CAVE .
- 3 Include the MSCID parameter set to the Serving MSC's identity information.
- 4 Include the SenderIdentificationNumber set to the identification number of the sending functional entity.
- 5 Send an AuthenticationFailureReport INVOKE to the MS's associated HLR.
- 6 Start the Authentication Failure Report Timer (AFRT).
- 7 WAIT for an Authentication Failure Report response:
- 8 WHEN a RETURN RESULT is received:
 - 8-1 Stop timer (AFRT).
 - 8-2 IF the message can be processed:
 - 8-2-1 IF the TerminalType (TERMTYP) parameter is not received (i.e., the VLR is using *TSB51* authentication procedures):
 - 8-2-1-1 IF *TSB51* operation is supported:
 - 8-2-1-1-1 Execute *TSB51* procedures for SecurityStatusReport (refer to *TIA/EIA TSB51*).
 - 8-2-1-1-2 Return to the invoking process.
 - 8-2-1-2 ELSE (*TSB51* operation is not supported):
 - 8-2-1-2-1 Execute the "Local Recovery Procedures" task (see 3.5.1).
 - 8-2-1-2-2 Return to the invoking process.
 - 8-2-1-3 ENDIF.
 - 8-2-2 ELSE (the TerminalType (TERMTYP) parameter is received, i.e., the VLR is using *IS-41-C* authentication procedures):
 - 8-2-2-1 IF the DenyAccess parameter is received:
 - 8-2-2-1-1 Include the DenyAccess parameter.
 - 8-2-2-2 ENDIF.
 - 8-2-2-3 IF the SSDNotShared (NOSSD) parameter is received:
 - 8-2-2-3-1 Remove the MS's current SharedSecretData (SSD) and AuthenticationAlgorithmVersion (AAV) from the VLR's database.
 - 8-2-2-4 ENDIF.
 - 8-2-2-5 IF the RandomVariableSSD (RANDSSD) is received:

1 8-2-2-5-1 IF SharedSecretData (SSD) is shared:
2
3 8-2-2-5-1-1 Remove the MS's current SharedSecretData (SSD) and
4 AuthenticationAlgorithmVersion (AAV) from the VLR's
5 database.
6 8-2-2-5-2 ENDIF.
7 8-2-2-5-3 Include the received RandomVariableSSD (RANDSSD) parameter.
8
9 8-2-2-5-4 Mark the MS *pending SSD update*.
10 8-2-2-5-5 IF the SharedSecretData (SSD) parameter was received:
11 8-2-2-5-5-1 IF the AuthenticationAlgorithmVersion (AAV) parameter is
12 received:
13 8-2-2-5-5-1-1 Store the AuthenticationAlgorithmVersion (AAV) value.
14 8-2-2-5-5-2 ENDIF.
15 8-2-2-5-5-3 Store the pending SSD value.
16 8-2-2-5-5-4 Select a RandomVariableUniqueChallenge (RANDU) and
17 execute CAVE using the value of the pending SSD to produce an
18 AuthenticationResponseUnique (AUTHU).
19 8-2-2-5-5-5 Include the RandomVariableUniqueChallenge (RANDU) and
20 AuthenticationResponseUnique (AUTHU) parameters.
21 8-2-2-5-5-6 Mark the MS *pending Unique Challenge*.
22 8-2-2-5-6 ELSE (the pending SSD was not received):
23 8-2-2-5-6-1 Relay the RandomVariableUniqueChallenge (RANDU)
24 parameter.
25 8-2-2-5-6-2 Relay the AuthenticationResponseUnique (AUTHU) parameter.
26 8-2-2-5-6-3 Mark the MS *pending Unique Challenge*.
27 8-2-2-5-7 ENDIF.
28 8-2-2-6 ELSE (the RandomVariableSSD (RANDSSD) was not received):
29 8-2-2-6-1 IF the SharedSecretData (SSD) parameter is received:
30 8-2-2-6-1-1 Store the SharedSecretData (SSD) value.
31 8-2-2-6-1-2 IF the AuthenticationAlgorithmVersion (AAV) parameter is
32 received:
33 8-2-2-6-1-2-1 Store the AuthenticationAlgorithmVersion (AAV) value.
34 8-2-2-6-1-3 ENDIF.
35 8-2-2-6-1-4 IF the CallHistoryCount (COUNT) parameter is received:
36 8-2-2-6-1-4-1 Store the received CallHistoryCount (COUNT) value.
37 8-2-2-6-1-5 ENDIF.
38 8-2-2-6-2 ENDIF.
39 8-2-2-6-3 IF the RandomVariableUniqueChallenge (RANDU) is received:
40 8-2-2-6-3-1 Include the received
41 RandomVariableUniqueChallenge(RANDU) and
42 AuthenticationResponseUnique (AUTHU) parameters.
43 8-2-2-6-3-2 Mark the MS *pending Unique Challenge*.
44 8-2-2-6-4 ENDIF.
45 8-2-2-7 ENDIF.

8-2-2-8	IF the UpdateCount (UPDCOUNT) parameter is received:	1
8-2-2-8-1	Include the received UpdateCount (UPDCOUNT) parameter.	2
8-2-2-8-2	Mark the MS <i>pending COUNT update</i> .	3
8-2-2-9	ENDIF.	4
8-2-2-10	IF the RETURN RESULT does not request that an AuthenticationDirective INVOKE shall be sent to the MSC serving the MS:	5
		6
8-2-2-10-1	Return to the invoking process.	7
8-2-2-11	ELSE:	8
		9
8-2-2-11-1	Send an AuthenticationDirective INVOKE to the MSC currently serving the MS.	10
		11
8-2-2-11-2	Start the Authentication Directive Timer (ADT).	12
		13
8-2-2-11-3	WAIT for an Authentication Directive response:	14
		15
8-2-2-11-4	WHEN a RETURN RESULT is received:	16
		17
8-2-2-11-4-1	Stop timer (ADT).	18
		19
8-2-2-11-4-2	IF the message can be processed:	20
		21
8-2-2-11-4-2-1	IF the MS is marked <i>pending SSD update</i> , OR IF the MS is marked <i>pending Unique Challenge</i> , OR IF the MS is marked <i>pending COUNT update</i> :	22
		23
		24
		25
8-2-2-11-4-2-1-1	Execute the “VLR AwaitingAuthenticationStatusReport INVOKE” task (see 4.5.2).	26
		27
		28
8-2-2-11-4-2-2	ENDIF.	29
		30
8-2-2-11-4-2-3	Return to the invoking process.	31
		32
8-2-2-11-4-3	ELSE (the message cannot be processed):	33
		34
8-2-2-11-4-3-1	IF the MS is marked <i>pending SSD update</i> :	35
		36
8-2-2-11-4-3-1-1	IF the pending SSD is stored in the VLR’s database:	37
		38
		39
		40
8-2-2-11-4-3-1-1-1	Remove the MS’s pending SharedSecretData (SSD) and AuthenticationAlgorithmVersion (AAV) from the VLR’s database.	41
		42
		43
8-2-2-11-4-3-1-2	ENDIF.	44
		45
8-2-2-11-4-3-2	ENDIF.	46
		47
8-2-2-11-4-3-3	Clear all the MS’s pending operation flags.	48
		49
8-2-2-11-4-3-4	Execute “Local Recovery Procedures” task (see 3.5.1).	50
		51
8-2-2-11-4-3-5	Return to the invoking process.	52
		53
8-2-2-11-4-4	ENDIF.	54
		55
8-2-2-11-5	WHEN a RETURN ERROR or REJECT is received:	56
		57
8-2-2-11-5-1	Stop timer (ADT).	58
		59
8-2-2-11-5-2	IF the MS is marked <i>pending SSD update</i> :	60
8-2-2-11-5-2-1	IF the pending SSD is stored in the VLR’s database:	
8-2-2-11-5-2-1-1	Remove the MS’s pending SharedSecretData (SSD) and AuthenticationAlgorithmVersion (AAV) from the VLR’s database.	
8-2-2-11-5-2-2	ENDIF.	

1 8-2-2-11-5-2-3 Clear all the MS's pending operation flags.
2
3 8-2-2-11-5-3 ENDIF.
4 8-2-2-11-5-4 Execute the "Local Recovery Procedures " task (see 3.5.1).
5 8-2-2-11-5-5 Return to the invoking process.
6
7 8-2-2-11-6 WHEN timer (ADT) expires:
8 8-2-2-11-6-1 Execute the "Local Recovery Procedures " task (see 3.5.1).
9 8-2-2-11-6-2 Return to the invoking process.
10
11 8-2-2-11-7 ENDWAIT.
12
13 8-2-2-12 ENDIF.
14
15 8-2-3 ENDIF.
16 8-3 ELSE (the message cannot be processed):
17 8-3-1 Execute the "Local Recovery Procedures " task (see 3.5.1).
18 8-3-2 Return to the invoking process.
19
20 8-4 ENDIF.
21 9 WHEN a RETURN ERROR or REJECT is received:
22 9-1 Stop timer (AFRT).
23 9-2 Execute the "Local Recovery Procedures " task (see 3.5.1).
24 9-3 Return to the invoking process.
25
26 10 WHEN timer (AFRT) expires:
27 10-1 Execute the "Local Recovery Procedures " task (see 3.5.1).
28 10-2 Return to the invoking process.
29
30 11 ENDWAIT.
31
32
33
34

4.4 AUTHENTICATION REQUEST

4.4.1 MSC Initiating an Authentication Request

The MSC shall start the authentication request process:

- a. when an authentication capable MS accesses the system and the AuthenticationCapability for the MS is not available, and
- b. when an authentication capable MS accesses the system and the MS's AuthenticationCapability status information indicates that authentication is required.

System accesses include autonomous registration, call origination, call termination, flash requests, power down (de-)registrations, and SMS page responses. On the assumption that the Anchor MSC is responsible for authenticating an MS before providing service, handoff into an MSC should not trigger the authentication request process in the new Serving MSC.

The Serving MSC shall perform the following:

- 1 IF authentication parameters were received:

- 1-1 Determine the value of the RandomVariable (RAND) used by the MS to compute its AuthenticationResponse(AUTHR) (see Annex A “Procedures for RANDC Verification”).
- 1-2 IF the value of RandomVariable (RAND) cannot be determined:
- 1-2-1 IF the value of RANDC received from the MS corresponds to a RandomVariable (RAND) value that may have been transmitted by a neighboring MSC:
- 1-2-1-1 Execute the “MSC Initiation of Random Variable Request” task (see 4.34.1).
- 1-2-1-2 IF the random variable request is unsuccessful:
- 1-2-1-2-1 Execute the “MSC Initiation of a Authentication Failure Report” task (see 4.3.1) with a ReportType parameter value of *RANDC mismatch*.
- 1-2-1-2-2 Exit this task with an *authentication failed* indication.
- 1-2-1-3 ELSE (random variable request is successful):
- 1-2-1-3-1 The RandomVariable (RAND) value received from the neighboring MSC shall be treated as the RandomVariable (RAND) used by the MS for this system access.
- 1-2-1-3-2 Continue this task.
- 1-2-1-4 ENDIF.
- 1-2-2 ELSE:
- 1-2-2-1 Execute the “MSC Initiation of a Authentication Failure Report” task (see 4.3.1) with a ReportType parameter value of *RANDC mismatch*.
- 1-2-2-2 Exit this task with an *authentication failed* indication.
- 1-2-3 ENDIF.
- 1-3 ENDIF.
- 2 ELSE (authentication parameters were not received):
- 2-1 IF AuthenticationCapability status indicates that the MS shall be authenticated:
- 2-1-1 Execute the “MSC Initiation of a Authentication Failure Report ” task (see 4.3.1) with a ReportType parameter value of *Missing authentication parameters*.
- 2-2 ENDIF.
- 3 ENDIF.
- 4 Include the SystemAccessType parameter set to indicate the type of access triggering the request (e.g., *Autonomous registration, Power down registration, Call origination, Page response, Flash request*).
- 5 Include the SystemCapabilities (SYSCAP) parameter indicating whether authentication parameters were requested for this system access.
- 6 Include the MSCID parameter set to the identity of the MSC.
- 7 IF authentication parameters were received:
- 7-1 Include the CallHistoryCount (COUNT) and AuthenticationResponse (AUTHR) parameters provided by the MS.
- 7-2 Include the RandomVariable (RAND) parameter used by the MS to compute the AuthenticationResponse (AUTHR) parameter.
- 7-3 Include the TerminalType (TERMTYP) parameter as declared by the MS.

- 1
2
3
4
5
6
7
8
9
10
11
12
13
14
15
16
17
18
19
20
21
22
23
24
25
26
27
28
29
30
31
32
33
34
35
36
37
38
39
40
41
42
43
44
45
46
47
48
49
50
51
52
53
54
55
56
57
58
59
60
- 7-4 IF the SystemAccessType parameter indicates a *Call origination* or *Flash request* with digits:
 - 7-4-1 Include the Digits (Dialed) parameter set to the decrypted digits received from the MS.
 - 7-4-2 IF the SystemAccessType parameter indicates a *Call origination* and air interface encoding of the dialed digits was not TBCD:
 - 7-4-2-1 Include the AuthenticationData parameter set to the value used by the MS to compute the AuthenticationResponse (AUTHR).
 - 7-4-3 ENDF.
 - 7-5 ENDF.
 - 7-6 IF the SystemAccessType parameter indicates a *Flash request* and the SignalingMessageEncryptionKey parameter was provided to the Serving MSC:
 - 7-6-1 Include the ConfidentialityModes (CMODES-actual) parameter indicating the current status of Signaling Message Encryption.
 - 7-7 ENDF.
 - 8 ENDF.
 - 9 Send an AuthenticationRequest INVOKE to the MSC's associated VLR.
 - 10 Start the Authentication Request Timer (ART).
 - 11 WAIT for an Authentication Request response:
 - 12 WHEN a RETURN RESULT is received:
 - 12-1 Stop timer (ART).
 - 12-2 IF the message can be processed:
 - 12-2-1 IF the TerminalType (TERMTYP) parameter is received (e.g., the AC is using *TSB51* authentication procedures):
 - 12-2-1-1 IF *TSB51* operation is supported:
 - 12-2-1-1-1 Execute *TSB51* procedures for AuthenticationRequest (refer to *TIA/EIA TSB51*).
 - 12-2-1-1-2 Return to the invoking process.
 - 12-2-1-2 ELSE (*TSB51* operation is not supported):
 - 12-2-1-2-1 Execute the "Local Recovery Procedures" task (see 3.5.1).
 - 12-2-1-2-2 Return to the invoking process.
 - 12-2-1-3 ENDF.
 - 12-2-2 ELSE (the TerminalType (TERMTYP) parameter is not received, (e.g., the AC is using *IS-41-C* authentication procedures):
 - 12-2-2-1 Execute the "MSC Receiving Authentication Parameters" task (see 4.1.6) using the parameters received.
 - 12-2-2-2 Return to the invoking process.
 - 12-2-3 ENDF.
 - 12-3 ELSE (the message cannot be processed):
 - 12-3-1 Execute the "Local Recovery Procedures " task (see 3.5.1).
 - 12-3-2 Return to the invoking process with an *authentication failed* indication.
 - 12-4 ENDF.
 - 13 WHEN a RETURN ERROR or REJECT is received:

- 13-1 Stop timer (ART). 1
- 13-2 Execute the “Local Recovery Procedures ” task (see 3.5.1). 2
- 13-3 Return to the invoking process with an *authentication failed* indication. 3
- 14 WHEN timer (ART) expires: 4
- 14-1 Execute the “Local Recovery Procedures ” task (see 3.5.1). 5
- 14-2 Return to the invoking process with an *authentication failed* indication. 6
- 15 ENDWAIT. 7

4.4.2 VLR Receiving AuthenticationRequest INVOKE

When a VLR receives an AuthenticationRequest INVOKE, it shall perform the following:

- 1 IF the received message can be processed: 16
- 1-1 IF the indicated MS’s AuthenticationCapability status information indicates that authentication is not required: 17
- 1-1-1 Send an AuthenticationRequest RETURN RESULT to the requesting MSC. 18
- 1-1-2 Exit this task. 19
- 1-2 ENDIF. 20
- 1-3 IF the MS is not allowed to register (e.g., the MS is on a negative list or registration attempts for the MS from same MSCID and LocationAreaID have failed in the recent past or the request is within a previously received DeniedAuthorizationPeriod): 21
- 1-3-1 Include the DenyAccess parameter set to *Unspecified*. 22
- 1-3-2 Send a RETURN RESULT to the requesting MSC. 23
- 1-3-3 Exit this task. 24
- 1-4 ENDIF. 25
- 1-5 IF the SharedSecretData (SSD) was provided to the VLR: 26
- 1-5-1 IF the MobileIdentificationNumber and ElectronicSerialNumber parameters reported by the MS cannot be validated: 27
- 1-5-1-1 Send an AuthenticationRequest RETURN RESULT to the requesting MSC. 28
- 1-5-1-2 Include the ReportType parameter set to *MIN/ESN Mismatch*. 29
- 1-5-1-3 Execute the “VLR Initiating an Authentication Failure Report” task (see 4.3.5). 30
- 1-5-1-4 Exit this task. 31
- 1-5-2 ENDIF. 32
- 1-5-3 IF the TerminalType (TERMTYP) reported for the MS is invalid: 33
- 1-5-3-1 Send an AuthenticationRequest RETURN RESULT to the requesting MSC. 34
- 1-5-3-2 Execute the “VLR Initiating an Authentication Failure Report ” task (see 4.3.5) with the ReportType parameter set to indicate *TERMT P mismatch*. 35
- 1-5-3-3 Exit this task. 36
- 1-5-4 ENDIF. 37

- 1
2
3
4
5
6
7
8
9
10
11
12
13
14
15
16
17
18
19
20
21
22
23
24
25
26
27
28
29
30
31
32
33
34
35
36
37
38
39
40
41
42
43
44
45
46
47
48
49
50
51
52
53
54
55
56
57
58
59
60
- 1-5-5 IF the SystemAccessType is *Autonomous registration, Power down registration, Call origination, Page response, or SMS page response*:
- 1-5-5-1 IF the received SystemCapabilities (SYSCAP) parameter indicates that the Serving MSC requested authentication parameters for this system access (AUTH=1 in the Overhead Message Train):
- 1-5-5-1-1 IF authentication parameters were not received from the MS:
- 1-5-5-1-1-1 Send an AuthenticationRequest RETURN RESULT to the requesting MSC.
- 1-5-5-1-1-2 Execute the “VLR Initiating an Authentication Failure Report ” task (see 4.3.5) with the ReportType parameter set to indicate *Missing authentication parameters* .
- 1-5-5-1-1-3 Exit this task.
- 1-5-5-1-2 ELSE (authentication parameters were received from the MS):
- 1-5-5-1-2-1 Convert values in the Digits (Dialed) parameter (if received) into TBCD encoding.
- 1-5-5-1-2-2 Execute CAVE using the value of the MS’s SharedSecretData(SSD) recorded in the VLR’s database and the parameters requested by the SystemAccessType.
- 1-5-5-1-2-3 IF the CAVE authentication result and the AuthenticationResponse (AUTHR) received from the MS (see Annex C “Authentication Response Verification”) do not match:
- 1-5-5-1-2-3-1 Send an AuthenticationRequest RETURN RESULT to the requesting MSC.
- 1-5-5-1-2-3-2 Execute the “VLR Initiating an Authentication Failure Report ” task (see 4.3.5) with the ReportType parameter set to indicate *AUTHR mismatch*.
- 1-5-5-1-2-3-3 Exit this task.
- 1-5-5-1-2-4 ENDIF.
- 1-5-5-1-2-5 IF the stored count and the CallHistoryCount (COUNT) reported by the MS do not match:
- 1-5-5-1-2-5-1 Send an AuthenticationRequest RETURN RESULT to the requesting MSC.
- 1-5-5-1-2-5-2 Include the CallHistoryCount (COUNT) parameter set to the COUNT reported by the MS.
- 1-5-5-1-2-5-3 Include the CallHistoryCountExpected parameter set to the COUNT expected by the VLR.
- 1-5-5-1-2-5-4 Execute the “VLR Initiating an Authentication Failure Report ” task (see 4.3.5) with the ReportType parameter set to indicate *COUNT mismatch*.
- 1-5-5-1-2-5-5 Exit this task.
- 1-5-5-1-2-6 ENDIF.
- 1-5-5-1-2-7 IF the SystemAccessType is *Call origination or Pageresponse*:
- 1-5-5-1-2-7-1 Generate the SignalingMessageEncryptionKey(SMEKEY) parameter.
- 1-5-5-1-2-7-2 Include the SignalingMessageEncryptionKey (SMEKEY) parameter.

1-5-5-1-2-7-3	IF the MS's Service Profile indicates that the MS subscribes to Voice Privacy:	1
		2
1-5-5-1-2-7-3-1	IF the MS supports TDMA:	3
1-5-5-1-2-7-3-1-1	Generate the VoicePrivacyMask (VPMASK).	4
1-5-5-1-2-7-3-1-2	Include the VoicePrivacyMask (VPMASK) parameter.	5
		6
1-5-5-1-2-7-3-2	ELSEIF the MS supports CDMA:	7
1-5-5-1-2-7-3-2-1	Generate the CDMAPrivateLongCodeMask(CDMAPLCM).	8
		9
1-5-5-1-2-7-3-2-2	Include the CDMAPrivateLongCodeMask(CDMAPLCM) parameter.	10
		11
1-5-5-1-2-7-3-3	ENDIF.	12
		13
1-5-5-1-2-7-4	ENDIF.	14
		15
1-5-5-1-2-8	ENDIF.	16
		17
1-5-5-1-3	ENDIF.	18
		19
1-5-5-2	ENDIF.	20
		21
1-5-6	ELSEIF the SystemAccessType is <i>Flash request</i> and the ConfidentialityModes (CMODES-Actual) parameter is received and the ConfidentialityModes (CMODES-Actual) indicates that Signaling MessageEncryption is inactive:	22
		23
1-5-6-1	Select a RandomVariableUniqueChallenge (RANDU) and execute CAVE using the value of the MS's SharedSecretData (SSD) recorded in the VLR's database to produce an AuthenticationResponseUnique(AUTHU).	24
		25
1-5-6-2	Include the RandomVariableUniqueChallenge (RANDU) and AuthenticationResponseUnique (AUTHU) parameters.	26
		27
1-5-6-3	Mark the MS <i>pending Unique Challenge</i> .	28
		29
1-5-7	ENDIF.	30
		31
1-5-8	IF local administrative procedures request that a Unique Challenge shall be initiated:	32
		33
1-5-8-1	Select a RandomVariableUniqueChallenge (RANDU) and execute CAVE using the value of the MS's SharedSecretData (SSD) recorded in the VLR's database to produce an AuthenticationResponseUnique(AUTHU).	34
		35
1-5-8-2	Include the RandomVariableUniqueChallenge (RANDU) and AuthenticationResponseUnique (AUTHU) parameters.	36
		37
1-5-8-3	Mark the MS <i>pending Unique Challenge</i> .	38
		39
1-5-9	ENDIF.	40
		41
1-5-10	IF local administrative procedures request that a COUNT update shall be initiated:	42
		43
1-5-10-1	Include the UpdateCount (UPDCOUNT) parameter.	44
		45
1-5-10-2	Mark the MS <i>pending COUNT update</i> .	46
		47
1-5-11	ENDIF.	48
		49
1-5-12	Send an AuthenticationRequest RETURN RESULT to the requesting MSC.	50
		51
1-5-13	IF the MS is marked <i>pending Unique Challenge</i> , OR IF the MS is marked <i>pending COUNT update</i> :	52
		53
		54
		55
		56
		57
		58
		59
		60

1 1-5-13-1 Execute the “VLR Awaiting AuthenticationStatusReport INVOKE” task
2 (see 4.5.2).
3
4 1-5-14 ENDIF.
5 1-5-15 Exit this task.
6
7 1-6 ELSE (the SharedSecretData (SSD) was not provided to the VLR):
8 1-6-1 Relay the SystemCapabilities (SYSCAP) parameter modified to indicate
9 whether the VLR is able to perform CAVE.
10 1-6-2 Include the SenderIdentificationNumber set to the identification number of the
11 sending functional entity.
12
13 1-6-3 Relay all other received parameters.
14 1-6-4 IF the VLR is sending the message to an SS7 network.
15 1-6-4-1 Include the PC_SSN parameter with the Type field set to *VLR* and the PC
16 and SSN fields set to the VLR’s point code and subsystem number.
17
18 1-6-5 ENDIF.
19 1-6-6 Send an AuthenticationRequest INVOKE to the HLR associated with the MS.
20 1-6-7 Start the Authentication Request Timer (ART).
21 1-6-8 WAIT for an Authentication Request response:
22 1-6-9 WHEN a RETURN RESULT is received:
23 1-6-9-1 Stop timer (ART).
24 1-6-9-2 IF the message can be processed:
25 1-6-9-2-1 IF the TerminalType (TERMTYP) parameter is received (i.e., the AC
26 is using *TSB51* authentication procedures):
27 1-6-9-2-1-1 IF *TSB51* operation is supported:
28 1-6-9-2-1-1-1 Execute *TSB51* procedures for AuthenticationRequest (refer
29 to *TIA/EIA*).
30 1-6-9-2-1-1-2 Exit this task.
31 1-6-9-2-1-2 ELSE (*TSB51* operation is not supported):
32 1-6-9-2-1-2-1 Execute the “Local Recovery Procedures” task (see 3.5.1).
33 1-6-9-2-1-2-2 Exit this task.
34 1-6-9-2-1-3 ENDIF.
35 1-6-9-2-2 ELSE (the TerminalType (TERMTYP) parameter is not received, i.e.,
36 the AC is using *IS-41-C* authentication procedures):
37 1-6-9-2-2-1 IF the DenyAccess parameter is received:
38 1-6-9-2-2-1-1 Relay the received DenyAccess parameter.
39 1-6-9-2-2-2 ENDIF.
40 1-6-9-2-2-3 IF the SSDNotShared (NOSSD) parameter is received:
41 1-6-9-2-2-3-1 Remove the MS’s current SharedSecretData (SSD) and
42 AuthenticationAlgorithmVersion (AAV) from the VLR’s
43 database.
44 1-6-9-2-2-4 ENDIF.
45 1-6-9-2-2-5 IF the RandomVariableSSD (RANDSSD) is received:
46 1-6-9-2-2-5-1 IF SharedSecretData (SSD) is shared:
47
48
49
50
51
52
53
54
55
56
57
58
59
60

1-6-9-2-2-5-1-1	Remove the MS's current SharedSecretData (SSD) and AuthenticationAlgorithmVersion (AAV) from the VLR's database.	1 2 3 4
1-6-9-2-2-5-2	ENDIF.	5
1-6-9-2-2-5-3	Relay the received RandomVariableSSD (RANDSSD) parameter.	6 7 8
1-6-9-2-2-5-4	Mark the MS <i>pending SSD update</i> .	9
1-6-9-2-2-5-5	IF the SharedSecretData (SSD) parameter is received:	10
1-6-9-2-2-5-5-1	Store the pending SharedSecretData (SSD) value.	11
1-6-9-2-2-5-5-2	IF the AuthenticationAlgorithmVersion (AAV) parameter is received:	12 13 14
1-6-9-2-2-5-5-2-1	Store the AuthenticationAlgorithmVersion(AAV) value.	15 16 17
1-6-9-2-2-5-5-3	ENDIF.	18
1-6-9-2-2-5-5-4	Select a RandomVariableUniqueChallenge(RANDU) and execute CAVE using the value of the pending SharedSecretData (SSD) to produce an AuthenticationResponseUnique (AUTHU).	19 20 21 22
1-6-9-2-2-5-5-5	Include the RandomVariableUniqueChallenge(RANDU) and AuthenticationResponseUnique(AUTHU) parameters.	23 24 25 26
1-6-9-2-2-5-5-6	Mark the MS <i>pending Unique Challenge</i> .	27
1-6-9-2-2-5-6	ELSE (SharedSecretData (SSD) parameter not received):	28
1-6-9-2-2-5-6-1	Relay the RandomVariableUniqueChallenge(RANDU) parameter.	29 30 31
1-6-9-2-2-5-6-2	Relay the AuthenticationResponseUnique (AUTHU) parameter.	32 33 34
1-6-9-2-2-5-6-3	Mark the MS <i>pending Unique Challenge</i> .	35
1-6-9-2-2-5-7	ENDIF.	36
1-6-9-2-2-6	ELSE (RandomVariableSSD (RANDSSD) not received):	37
1-6-9-2-2-6-1	IF the SharedSecretData (SSD) parameter is received:	38
1-6-9-2-2-6-1-1	Store the SharedSecretData (SSD) .	39 40
1-6-9-2-2-6-1-2	IF the AuthenticationAlgorithmVersion (AAV) parameter is received:	41 42 43
1-6-9-2-2-6-1-2-1	Store the AuthenticationAlgorithmVersion(AAV) value.	44 45 46
1-6-9-2-2-6-1-3	ENDIF.	47
1-6-9-2-2-6-1-4	IF the CallHistoryCount (COUNT) parameter is received:	48 49
1-6-9-2-2-6-1-4-1	Store the received CallHistoryCount (COUNT) value.	50 51 52
1-6-9-2-2-6-1-5	ENDIF.	53
1-6-9-2-2-6-2	ENDIF.	54 55
1-6-9-2-2-6-3	IF the RandomVariableUniqueChallenge (RANDU) is received:	56 57 58 59 60

1 1-6-9-2-2-6-3-1 Relay the received
2 RandomVariableUniqueChallenge(RANDU) and
3 AuthenticationResponseUnique(AUTHU) parameters.
4
5 1-6-9-2-2-6-3-2 Mark the MS *pending Unique Challenge*.
6 1-6-9-2-2-6-4 ENDIF.
7
8 1-6-9-2-2-7 ENDIF.
9 1-6-9-2-2-8 IF UpdateCount (UPDCOUNT) is received:
10 1-6-9-2-2-8-1 Relay the received UpdateCount (UPDCOUNT) parameter.
11 1-6-9-2-2-8-2 Mark the MS *pending COUNT update*.
12 1-6-9-2-2-9 ENDIF.
13 1-6-9-2-2-10 IF the SignalingMessageEncryptionKey (SMEKEY) is available:
14 1-6-9-2-2-10-1 Relay the SignalingMessageEncryptionKey (SMEKEY)
15 parameter.
16 1-6-9-2-2-11 ENDIF.
17 1-6-9-2-2-12 IF the VoicePrivacyMask (VPMASK) is received:
18 1-6-9-2-2-12-1 Relay the VoicePrivacyMask (VPMASK) parameter.
19 1-6-9-2-2-13 ENDIF.
20 1-6-9-2-2-14 IF the CDMAPrivateLongCodeMask (CDMAPLCM) is
21 received:
22 1-6-9-2-2-14-1 Relay the CDMAPrivateLongCodeMask (CDMAPLCM)
23 parameter.
24 1-6-9-2-2-15 ENDIF.
25 1-6-9-2-2-16 Send an AuthenticationRequest RETURN RESULT to the
26 requesting MSC.
27 1-6-9-2-2-17 IF the MS is marked *pending SSD update*, OR IF the MS is
28 marked *pending Unique Challenge*, OR IF the MS is marked
29 *pending COUNT update*:
30 1-6-9-2-2-17-1 Execute the “VLR Awaiting
31 AuthenticationStatusReportINVOKE” task (see 4.5.2).
32 1-6-9-2-2-18 ENDIF.
33 1-6-9-2-2-19 Exit this task.
34 1-6-9-2-3 ENDIF.
35 1-6-9-3 ELSE (the message cannot be processed):
36 1-6-9-3-1 Send a RETURN ERROR to the MSC with the Error Code indicating
37 *SystemFailure*.
38 1-6-9-3-2 Execute the “Local Recovery Procedures” task (see 3.5.1).
39 1-6-9-3-3 Exit this task.
40 1-6-9-4 ENDIF.
41 1-6-10 WHEN a RETURN ERROR or REJECT is received:
42 1-6-10-1 Stop timer (ART).
43 1-6-10-2 CASE Error Code OF:
44 1-6-10-3 *ParameterError*:
45 1-6-10-3-1 IF the parameter was originated from the initiating functional entity:
46
47
48
49
50
51
52
53
54
55
56
57
58
59
60

1-6-10-3-1-1	Send a RETURN ERROR with the Error Code indicating <i>ParameterError</i> .	1
		2
1-6-10-3-2	ELSE:	3
		4
1-6-10-3-2-1	Send a RETURN ERROR with the Error Code indicating <i>SystemFailure</i> .	5
		6
1-6-10-3-3	ENDIF.	7
		8
1-6-10-4	DEFAULT:	9
		10
1-6-10-4-1	Send a RETURN ERROR with the Error Code indicating <i>SystemFailure</i> .	11
		12
1-6-10-5	ENDCASE.	13
1-6-10-6	Execute the "Local Recovery Procedures " task (see 3.5.1).	14
1-6-10-7	Exit this task.	15
		16
1-6-11	WHEN timer (ART) expires:	17
		18
1-6-11-1	Send a RETURN ERROR to the MSC with the Error Code indicating <i>SystemFailure</i> .	19
		20
1-6-11-2	Execute the "Local Recovery Procedures " task (see 3.5.1).	21
1-6-11-3	Exit this task.	22
		23
1-6-12	ENDWAIT.	24
1-7	ENDIF.	25
		26
2	ELSE (the received message cannot be processed):	27
		28
2-1	Send a RETURN ERROR to the requesting MSC with the proper Error Code value (see the following table).	29
		30
3	ENDIF.	31
		32
4	Exit this task.	33
		34
		35
		36
		37
		38
		39
		40
		41
		42
		43
		44
		45
		46
		47
		48
		49
		50
		51
		52
		53
		54
		55
		56
		57
		58
		59
		60

Table 8 VLR AuthenticationRequest Response

Problem Detection and Recommended Response from VLR to MSC									
PROBLEM DEFINITION	1	2	3	4	5	6	7	8	Notes
RETURN ERROR									
Error Code									
<i>UnrecognizedMIN</i>									a
<i>UnrecognizedESN</i>									a
<i>MIN/HLRMismatch</i>						X			e
<i>OperationSequenceProblem</i>									a
<i>ResourceShortage</i>		X							e
<i>OperationNotSupported</i>	X								b, e
<i>TrunkUnavailable</i>									a
<i>ParameterError</i>				X					d, e
<i>SystemFailure</i>			X						e
<i>UnrecognizedParameterValue</i>					X				d, e
<i>FeatureInactive</i>									a
<i>MissingParameter</i>							X		d, e
RETURN RESULT DenyAccess								X	c, e

Problem Detections:

1. The requested MAP operation is recognized, but not supported, by the receiving VLR, or the requesting functional entity is not authorized.
2. A required VLR resource (e.g., internal memory record, VLR is fully occupied) is temporarily not available (e.g., congestion).
3. A required resource (e.g., data base access, functional entity) is not presently accessible due to a failure. Human intervention may be required for resolution.
4. A supplied parameter has an encoding problem (e.g., the supplied MobileIdentificationNumber parameter digit values do not meet the BCD specification); or, two or more mutually exclusive parameters have been supplied (e.g., Digits (Dialed) parameter received, but SystemAccessType is not *Call origination*).
5. A supplied parameter value is unrecognized or has nonstandard values (e.g., *Not used*).
6. The supplied MobileIdentificationNumber parameter's AC (HLR) responded that the MIN is not in the AC (HLR)'s range of MINs or Directory Numbers (suspect routing error).
7. An optional parameter required by the AC (HLR) was expected, but not received (e.g., SystemCapabilities (SYSCAP) parameter indicated authentication is supported (AUTH=1) but AuthenticationResponse (AUTHR), ConfidentialityModes (CMODES), CallHistoryCount (COUNT) and/or RandomVariable (RAND) parameters was not received; or SystemAccessType indicated *Call origination*, but Digits (Dialed) parameter was not received).
8. The supplied MobileIdentificationNumber parameter's AC (HLR) responded that the MIN cannot be Authenticated because of the reason identified by the supplied DenyAccess parameter value.

Notes:

- a. This Error Code is not an appropriate VLR response to an AuthenticationRequest transaction.
- b. It is recommended that a VLR supports AuthenticationRequest transactions.
- c. Only RETURN RESULT operations needing clarification have been included.
- d. Include the *Parameter Identifier* in question as the FaultyParameter parameter.
- e. This response may have been originated by the AC (HLR).

4.4.3 HLR Receiving AuthenticationRequest INVOKE

When an HLR receives an AuthenticationRequest INVOKE, it shall perform the following:

- 1 IF the received message can be processed:
 - 1-1 Include the SenderIdentificationNumber set to the identification number of the HLR.
 - 1-2 Relay all other received parameters.
 - 1-3 Send an AuthenticationRequest INVOKE to the AC associated with the MS.
 - 1-4 Start the Authentication Request Timer (ART).
 - 1-5 WAIT for an Authentication Request response:
 - 1-6 WHEN a RETURN RESULT is received:
 - 1-6-1 Stop timer (ART).
 - 1-6-2 IF the message can be processed:
 - 1-6-2-1 IF the MS's service profile indicates that the MS is not authorized for Voice Privacy:
 - 1-6-2-1-1 Discard any received VoicePrivacyMask (VPMASK) or CDMAPrivateLongCodeMask (CDMAPLCM) parameters.
 - 1-6-2-2 ENDIF.
 - 1-6-2-3 Relay all other received parameters.
 - 1-6-2-4 Send a RETURN RESULT to the requesting VLR.
 - 1-6-2-5 Exit this task.
 - 1-6-3 ELSE (the message cannot be processed):
 - 1-6-3-1 Send a RETURN ERROR to the requesting VLR with the Error Code indicating *SystemFailure*.
 - 1-6-3-2 Execute the "Local Recovery Procedures" task (see 3.5.1).
 - 1-6-3-3 Exit this task.
 - 1-6-4 ENDIF.
 - 1-7 WHEN a RETURN ERROR or REJECT is received:
 - 1-7-1 Stop timer (ART).
 - 1-7-2 CASE Error Code OF:
 - 1-7-3 *ParameterError*:
 - 1-7-3-1 Send a RETURN ERROR to the requesting VLR with the Error Code indicating *ParameterError*.
 - 1-7-4 *DEFAULT*:
 - 1-7-4-1 Send a RETURN ERROR to the requesting VLR with the Error Code indicating *SystemFailure*.
 - 1-7-5 ENDCASE.
 - 1-7-6 Execute the "Local Recovery Procedures " task (see 3.5.1).
 - 1-7-7 Exit this task.
 - 1-8 WHEN timer (ART) expires:
 - 1-8-1 Send a RETURN ERROR to the requesting VLR with the Error Code indicating *SystemFailure*.
 - 1-8-2 Execute the "Local Recovery Procedures " task (see 3.5.1).

- 1-8-3 Exit this task.
 1-9 ENDWAIT.
 2 ELSE (the received message cannot be processed):
 2-1 Send a RETURN ERROR to the requesting VLR.
 3 ENDIF.
 4 Exit this task

Table 9 HLR AuthenticationRequest Response

Problem Detection and Recommended Response from HLR to VLR									
PROBLEM DEFINITION	1	2	3	4	5	6	7	8	Notes
RETURN ERROR Error Code									
<i>UnrecognizedMIN</i>									a
<i>UnrecognizedESN</i>									a
<i>MIN/HLRMismatch</i>						X			
<i>OperationSequenceProblem</i>									a
<i>ResourceShortage</i>		X							
<i>OperationNotSupported</i>	X								b
<i>TrunkUnavailable</i>									a
<i>ParameterError</i>				X					d, e
<i>SystemFailure</i>			X						e
<i>UnrecognizedParameterValue</i>					X				d
<i>FeatureInactive</i>									a
<i>MissingParameter</i>							X		d
RETURN RESULT DenyAccess								X	c, e

Problem Detections:

- The requested MAP operation is recognized, but not supported, by the receiving HLR, or the requesting functional entity is not authorized.
- A required HLR resource (e.g., internal memory record, HLR is fully occupied) is temporarily not available (e.g., congestion).
- A required resource (e.g., data base access, functional entity) is not presently accessible due to a failure. Human intervention may be required for resolution.
- A supplied parameter has an encoding problem (e.g., the supplied MobileIdentificationNumber parameter digit values do not meet the BCD specification); or, two or more mutually exclusive parameters have been supplied (e.g., Digits (Dialed) parameter received, but SystemAccessType is not *Call origination*).
- A supplied parameter value is unrecognized or has nonstandard values (e.g., *Not used*).
- The supplied MobileIdentificationNumber parameter is not in the HLR's range of MINs or Directory Numbers (suspect routing error).
- An optional parameter required by the HLR (AC) was expected, but not received (e.g., SystemCapabilities (SYSCAP) parameter indicated authentication is supported (AUTH=1) but AuthenticationResponse (AUTHR), ConfidentialityModes (CMODES), CallHistoryCount (COUNT) and/or RandomVariable (RAND) parameters was not received; or SystemAccessType indicated *Call origination*, but Digits (Dialed) parameter was not received).
- The supplied MobileIdentificationNumber parameter's AC (HLR) responded that the MIN cannot be Authenticated because of the reason identified by the supplied DenyAccess parameter value.

Notes:

- This Error Code is not an appropriate HLR response to an AuthenticationRequest transaction.

- b. It is recommended that a HLR supports AuthenticationRequest transactions.
- c. Only RETURN RESULT operations needing clarification have been included.
- d. Include the *Parameter Identifier* in question as the FaultyParameter parameter.
- e. This response may have been originated by the AC.

4.4.4 AC Receiving AuthenticationRequest INVOKE

When an AC receives an AuthenticationRequest INVOKE, it shall perform the following:

- 1 IF the received message can be processed:
 - 1-1 IF the TerminalType (TERMTYP) parameter is not received (i.e., the VLR is using *TSB51* authentication procedures):
 - 1-1-1 IF *TSB51* operation is supported:
 - 1-1-1-1 Execute *TSB51* procedures for AuthenticationRequest (refer to *TIA/EIA TSB51*).
 - 1-1-1-2 Exit this task.
 - 1-1-2 ELSE (*TSB51* operation is not supported):
 - 1-1-2-1 Send a RETURN ERROR with the error code set to *OperationNotSupported*.
 - 1-1-2-2 Exit this task.
 - 1-1-3 ENDIF.
 - 1-2 ELSE (the TerminalType (TERMTYP) parameter is received, i.e., the VLR is using *IS-41-C* authentication procedures):
 - 1-2-1 IF the MobileIdentificationNumber and ElectronicSerialNumber parameters reported by the MS cannot be validated:
 - 1-2-1-1 Include the DenyAccess parameter set to indicate *MIN* or *ESNauthorization failure*.
 - 1-2-1-2 Send a RETURN RESULT to the requesting HLR.
 - 1-2-1-3 Exit this task.
 - 1-2-2 ENDIF.
 - 1-2-3 IF the TerminalType (TERMTYP) reported for the MS is not valid:
 - 1-2-3-1 IF access shall be denied to the MS:
 - 1-2-3-1-1 Include the DenyAccess parameter set to indicate *TerminalTypemismatch*.
 - 1-2-3-1-2 Send a RETURN RESULT to the requesting HLR.
 - 1-2-3-1-3 Exit this task.
 - 1-2-3-2 ENDIF.
 - 1-2-4 ENDIF:
 - 1-2-5 IF the SystemAccessType is *FlashRequest* AND IF the ConfidentialityModes (CMODES-Actual) parameter was received AND IF the ConfidentialityModes (CMODES-Actual) parameter indicates that Signaling Message Encryption is *inactive*:
 - 1-2-5-1 Select a RandomVariableUniqueChallenge (RANDU) and execute CAVE using the value of the MS's SharedSecretData (SSD) recorded in the AC's database to produce an AuthenticationResponseUnique(AUTHU).

1 1-2-5-2 Include the RandomVariableUniqueChallenge (RANDU) and
2 AuthenticationResponseUnique (AUTHU) parameters.
3
4 1-2-5-3 Mark the MS *pending Unique Challenge*.
5
6 1-2-6 ENDIF.
7
8 1-2-7 IF the SystemAccessType is *Call origination, Page response, SMS*
9 *pageresponse, Power down registration, or Autonomous registration*:
10
11 1-2-7-1 IF the received SystemCapabilities (SYSCAP) parameter indicates that
12 the Serving MSC requested authentication parameters for this system
13 access (AUTH=1 in the Overhead Message Train):
14
15 1-2-7-1-1 IF authentication parameters were not received from the MS:
16
17 1-2-7-1-1-1 IF access shall be denied to the MS:
18
19 1-2-7-1-1-1-1 Include the DenyAccess parameter set to indicate *Missing*
20 *authentication parameters*.
21
22 1-2-7-1-1-1-2 Send a RETURN RESULT to the requesting HLR.
23
24 1-2-7-1-1-1-3 Exit this task.
25
26 1-2-7-1-1-2 ENDIF.
27
28 1-2-7-1-2 ELSE (authentication parameters were received from the MS):
29
30 1-2-7-1-2-1 Convert values in the Digits (Dialed) parameter (if received) into
31 TBCD encoding.
32
33 1-2-7-1-2-2 Execute CAVE using the value of the MS's
34 SharedSecretData(SSD) recorded in the AC's database and the
35 parameters requested by the received SystemAccessType
36 parameter.
37
38 1-2-7-1-2-3 IF the CAVE authentication result and the
39 AuthenticationResponse (AUTHR) received from the MS (see
40 Annex C "Authentication Response Verification") match:
41
42 1-2-7-1-2-3-1 IF SharedSecretData (SSD) is presently shared with another
43 VLR:
44
45 1-2-7-1-2-3-1-1 Execute the "AC Initiating a COUNT Request" task
46 (see 4.10.1).
47
48 1-2-7-1-2-3-2 ENDIF.
49
50 1-2-7-1-2-3-3 IF the stored count and the CallHistoryCount (COUNT)
51 reported by the MS do not significantly match:
52
53 1-2-7-1-2-3-3-1 IF access shall be denied to the MS:
54
55 1-2-7-1-2-3-3-1-1 Include the DenyAccess parameter set to indicate
56 *COUNT mismatch*.
57
58 1-2-7-1-2-3-3-1-2 Send a RETURN RESULT to the requesting HLR.
59
60 1-2-7-1-2-3-3-1-3 Exit this task.
61
62 1-2-7-1-2-3-3-2 ENDIF.
63
64 1-2-7-1-2-3-4 ENDIF.
65
66 1-2-7-1-2-3-5 IF the SystemAccessType is *Call origination* or *Page*
67 *response*:
68
69 1-2-7-1-2-3-5-1 Generate the
70 SignalingMessageEncryptionKey(SMEKEY).

1-2-7-1-2-3-5-2	Include	the	1
	SignalingMessageEncryptionKey(SMEKEY)		2
	parameter.		3
			4
1-2-7-1-2-3-5-3	IF the MS supports TDMA:		5
1-2-7-1-2-3-5-3-1	Generate the VoicePrivacyMask (VPMASK).		6
1-2-7-1-2-3-5-3-2	Include the VoicePrivacyMask (VPMASK)		7
	parameter.		8
			9
1-2-7-1-2-3-5-4	ELSEIF the MS supports CDMA:		10
1-2-7-1-2-3-5-4-1	Generate	the	11
	CDMAPrivateLongCodeMask(CDMAPLCM).		12
			13
1-2-7-1-2-3-5-4-2	Include	the	14
	CDMAPrivateLongCodeMask(CDMAPLCM)		15
	parameter.		16
			17
1-2-7-1-2-3-5-5	ENDIF.		18
1-2-7-1-2-3-6	ENDIF.		19
1-2-7-1-2-4	ELSE (AuthenticationResponse (AUTHR) reported by the MS is		20
	invalid):		21
			22
1-2-7-1-2-4-1	IF access shall be denied to the MS:		23
1-2-7-1-2-4-1-1	Include the DenyAccess parameter set to indicate		24
	<i>AUTHR mismatch</i> .		25
			26
1-2-7-1-2-4-1-2	Send a RETURN RESULT to the requesting HLR.		27
1-2-7-1-2-4-1-3	Exit this task.		28
			29
1-2-7-1-2-4-2	ENDIF.		30
1-2-7-1-2-4-3	IF SharedSecretData (SSD) is presently shared with another		31
	VLR:		32
1-2-7-1-2-4-3-1	Execute the "AC Initiating a COUNT Request" task		33
	(see 4.10.1).		34
			35
1-2-7-1-2-4-4	ENDIF.		36
1-2-7-1-2-4-5	Validate the CallHistoryCount (COUNT) reported by the		37
	MS.		38
			39
1-2-7-1-2-4-6	IF the COUNT is not valid:		40
1-2-7-1-2-4-6-1	IF access shall be denied to the MS:		41
1-2-7-1-2-4-6-1-1	Include the DenyAccess parameter set to indicate		42
	<i>COUNT mismatch</i> .		43
			44
1-2-7-1-2-4-6-1-2	Send a RETURN RESULT to the requesting HLR.		45
1-2-7-1-2-4-6-1-3	Exit this task.		46
			47
1-2-7-1-2-4-6-2	ENDIF.		48
			49
1-2-7-1-2-4-7	ENDIF.		50
1-2-7-1-2-5	ENDIF.		51
1-2-7-1-3	ENDIF.		52
1-2-7-2	ENDIF.		53
1-2-8	ENDIF.		54
1-2-9	IF SharedSecretData (SSD) presently shared with the VLR shall be discarded:		55
1-2-9-1	Include the SSDNotShared (NOSSD) parameter.		56
			57
			58
			59
			60

1 1-2-10 ENDIF.

2 1-2-11 IF an SSD update shall be initiated:

3

4 1-2-11-1 Select a RandomVariableSSD (RANDSSD) and execute CAVE using the

5 value of the MS's A-key recorded in the AC's database to produce a

6 pending SSD.

7

8 1-2-11-2 Include the RandomVariableSSD (RANDSSD) parameter.

9 1-2-11-3 Mark the MS *pending SSD update*.

10 1-2-11-4 IF AC administrative procedures indicate that the pending SSD shall be

11 shared with the VLR for the SSD update operation:

12

13 1-2-11-4-1 IF the received SystemCapabilities (SYSCAP) parameter indicates

14 that the VLR is able to execute the CAVE algorithm:

15 1-2-11-4-1-1 Include the SharedSecretData (SSD) parameter set to the

16 pending SSD value.

17 1-2-11-4-1-2 IF the AuthenticationAlgorithmVersion (AAV) parameter for

18 this MS is different than the default value:

19 1-2-11-4-1-2-1 Include the AuthenticationAlgorithmVersion (AAV)

20 parameter.

21 1-2-11-4-1-3 ENDIF.

22 1-2-11-4-2 ENDIF.

23 1-2-11-5 ELSE (the pending SSD is not shared):

24

25 1-2-11-5-1 Select a RandomVariableUniqueChallenge (RANDU) and execute

26 CAVE using the value of the pending SSD to produce an

27 AuthenticationResponseUnique (AUTHU).

28 1-2-11-5-2 Include the RandomVariableUniqueChallenge (RANDU) and

29 AuthenticationResponseUnique (AUTHU) parameters.

30 1-2-11-5-3 Mark the MS *pending Unique Challenge*.

31 1-2-11-6 ENDIF.

32 1-2-12 ELSE (SSD update not initiated):

33

34 1-2-12-1 IF the SharedSecretData (SSD) shall be shared with the VLR:

35

36 1-2-12-1-1 IF the received SystemCapabilities (SYSCAP) indicates the VLR is

37 capable of executing the CAVE algorithm.

38 1-2-12-1-1-1 Include the SharedSecretData (SSD) and

39 CallHistoryCount(COUNT) parameters.

40 1-2-12-1-1-2 IF the AuthenticationAlgorithmVersion (AAV) parameter for

41 this MS is different than the default value:

42 1-2-12-1-1-2-1 Include the AuthenticationAlgorithmVersion (AAV)

43 parameter.

44 1-2-12-1-1-3 ENDIF.

45 1-2-12-1-2 ENDIF.

46 1-2-12-2 ENDIF.

47 1-2-12-3 IF local administrative procedures request that a Unique Challenge shall

48 be initiated:

49 1-2-12-3-1 Select a RandomVariableUniqueChallenge (RANDU) and execute

50 CAVE using the value of the MS's SharedSecretData (SSD) recorded

51

52

53

54

55

56

57

58

59

60

	in the AC's database to produce an AuthenticationResponseUnique (AUTHU).	1
		2
		3
1-2-12-3-2	Include the RandomVariableUniqueChallenge (RANDU) and AuthenticationResponseUnique (AUTHU) parameters.	4
		5
1-2-12-3-3	Mark the MS <i>pending Unique Challenge</i> .	6
		7
1-2-12-4	ENDIF.	8
		9
1-2-13	ENDIF.	10
		11
1-2-14	IF local administrative procedures request that a COUNT update shall be initiated:	12
		13
1-2-14-1	Include the UpdateCount (UPDCOUNT) parameter.	14
		15
1-2-14-2	Mark the MS <i>pending COUNT update</i> .	16
		17
1-2-15	ENDIF.	18
		19
1-2-16	Send an AuthenticationRequest RETURN RESULT to the requesting HLR.	20
		21
1-2-17	IF the MS is marked <i>pending SSD update</i> , OR IF the MS is marked <i>pendingUnique Challenge</i> , OR IF the MS is marked <i>pending COUNT update</i> :	22
		23
1-2-17-1	Execute the "AC Awaiting AuthenticationStatusReport INVOKE" task (see 4.5.4).	24
		25
1-2-18	ENDIF.	26
		27
1-2-19	Exit this task.	28
		29
1-3	ENDIF.	30
		31
2	ELSE (the received message cannot be processed):	32
		33
2-1	Send a RETURN ERROR to the requesting HLR.	34
		35
3	ENDIF.	36
		37
4	Exit this task.	38
		39
		40
		41
		42
		43
		44
		45
		46
		47
		48
		49
		50
		51
		52
		53
		54
		55
		56
		57
		58
		59
		60

Table 10 AC AuthenticationRequest Response

Problem Detection and Recommended Response from AC to HLR									
PROBLEM DEFINITION	1	2	3	4	5	6	7	8	Notes
RETURN ERROR									
Error Code									
<i>UnrecognizedMIN</i>									a
<i>UnrecognizedESN</i>									a
<i>MIN/HLRMismatch</i>						X			
<i>OperationSequenceProblem</i>									a
<i>ResourceShortage</i>		X							
<i>OperationNotSupported</i>	X								b
<i>TrunkUnavailable</i>									a
<i>ParameterError</i>				X					d
<i>SystemFailure</i>			X						
<i>UnrecognizedParameterValue</i>					X				d
<i>FeatureInactive</i>									a
<i>MissingParameter</i>							X		d
RETURN RESULT DenyAccess								X	c, e

Problem Detections:

1. The requested MAP operation is recognized, but not supported, by the receiving AC, or the requesting functional entity is not authorized.
2. A required AC resource (e.g., internal memory record, AC is fully occupied) is temporarily not available (e.g., congestion).
3. A required resource (e.g., data base access, functional entity) is not presently accessible due to a failure. Human intervention may be required for resolution.
4. A supplied parameter has an encoding problem (e.g., the supplied MobileIdentificationNumber parameter digit values do not meet the BCD specification); or, two or more mutually exclusive parameters have been supplied (e.g., Digits (Dialed) parameter received, but SystemAccessType is not *Call origination*).
5. A supplied parameter value is unrecognized or has nonstandard values (e.g., *Not used*).
6. The supplied MobileIdentificationNumber parameter is not in the AC's range of MINs or Directory Numbers (suspect routing error).
7. An optional parameter required by the AC was expected, but not received (e.g., SystemCapabilities (SYSCAP) parameter indicated authentication is supported (AUTH=1) but AuthenticationResponse (AUTHR), ConfidentialityModes (CMODES), CallHistoryCount(COUNT) and/or RandomVariable (RAND) parameters was not received; or SystemAccessType indicated *Call origination*, but Digits (Dialed) parameter was not received).
8. The supplied MobileIdentificationNumber parameter's AC responded that the MIN cannot be Authenticated because of the reason identified by the supplied DenyAccess parameter value.

Notes:

- a. This Error Code is not an appropriate AC response to an AuthenticationRequest transaction.
- b. It is recommended that an AC supports AuthenticationRequest transactions.
- c. Only RETURN RESULT operations needing clarification have been included.
- d. Include the *Parameter Identifier* in question as the FaultyParameter parameter.
- e. This DenyAccess reason is not an appropriate AC response to an AuthenticationRequest transaction.

4.5 AUTHENTICATION STATUS REPORT

4.5.1 MSC Initiating an Authentication Status Report

When an MSC determines that an Authentication Status Report is necessary to report the outcome of authentication operations requested by the VLR, it shall perform the following:

- 1 IF the outcome of an SSD update shall be reported:
 - 1-1 Include the SSDUpdateReport parameter set to the value indicated by the calling task.
- 2 ENDIF.
- 3 IF the outcome of a Unique Challenge shall be reported:
 - 3-1 Include the UniqueChallengeReport parameter set to the value indicated by the calling task.
- 4 ENDIF.
- 5 IF the outcome of a COUNT update shall be reported:
 - 5-1 Include the CountUpdateReport parameter set to the value indicated by the calling task.
- 6 ENDIF.
- 7 Include the SenderIdentificationNumber set to the identification number of the sending functional entity.
- 8 Include the SystemCapabilities (SYSCAP) parameter indicating whether authentication parameters were requested for this system access.
- 9 Send an AuthenticationStatusReport INVOKE to the MSC's associated VLR.
- 10 Start the Authentication Status Report Timer (ASRT).
- 11 WAIT for an Authentication Status Report response:
- 12 WHEN a RETURN RESULT is received:
 - 12-1 Stop timer (ASRT).
 - 12-2 IF the message can be processed:
 - 12-2-1 Execute the "MSC Receiving Authentication Parameters" task (see 4.1.6) using the parameters received.
 - 12-2-2 Return to the invoking process.
 - 12-3 ELSE (the message cannot be processed):
 - 12-3-1 Execute the "Local Recovery Procedures" task (see 3.5.1).
 - 12-3-2 Return to the invoking process.
- 12-4 ENDIF.
- 13 WHEN a RETURN ERROR or REJECT is received:
 - 13-1 Stop timer (ASRT).
 - 13-2 Execute the "Local Recovery Procedures" task (see 3.5.1).
 - 13-3 Return to the invoking process.
- 14 WHEN timer (ASRT) expires:
 - 14-1 Execute the "Local Recovery Procedures" task (see 3.5.1).

- 14-2 Return to the invoking process.
 15 ENDWAIT.

4.5.2 VLR Awaiting AuthenticationStatusReport INVOKE

When a VLR requests the Serving MSC to perform authentication operations that require the Serving MSC to report the outcome, the VLR shall perform the following:

- 1 Start the Authentication Status Report Response Timer (ASRRT).
- 2 WAIT for an AuthenticationStatusReport INVOKE:
- 3 WHEN an AuthenticationStatusReport INVOKE is received:
 - 3-1 Stop timer (ASRRT).
 - 3-2 IF the received message can be processed:
 - 3-2-1 IF the AuthenticationStatusReport INVOKE reports the outcome of operations initiated by the VLR:
 - 3-2-1-1 Clear all the MS's pending operation flags.
 - 3-2-1-2 Send a RETURN RESULT to the requesting MSC.
 - 3-2-1-3 IF COUNT updating has been completed:
 - 3-2-1-3-1 Increment the value of CallHistoryCount (COUNT) in the VLR's database.
 - 3-2-1-4 ENDIF.
 - 3-2-1-5 IF all of the authentication operations initiated by the VLR have been successfully completed:
 - 3-2-1-5-1 Exit this task.
 - 3-2-1-6 ELSE (the INVOKE reports the failure of an authentication operation initiated by the VLR):
 - 3-2-1-6-1 Execute the "VLR Initiating an Authentication Failure Report" task (see 4.3.5) with the ReportType parameter set to indicate the authentication failure reported by the Serving MSC.
 - 3-2-1-6-2 Exit this task.
 - 3-2-1-7 ENDIF.
 - 3-2-2 ENDIF.
 - 3-2-3 IF the MS is marked *pending SSD update*:
 - 3-2-3-1 IF the pending SSD is stored in the VLR's database:
 - 3-2-3-1-1 Remove the pending SharedSecretData (SSD) and AuthenticationAlgorithmVersion (AAV) from the VLR's database.
 - 3-2-3-2 ENDIF.
 - 3-2-4 ENDIF.
 - 3-2-5 Clear all the MS's pending operation flags.
 - 3-2-6 Relay the received SystemCapabilities (SYSCAP) parameter modifying it to indicate whether the VLR is able to execute CAVE .
 - 3-2-7 Include the SenderIdentificationNumber set to the identification number of the VLR.
 - 3-2-8 Relay all other received parameters.

3-2-9	Send an AuthenticationStatusReport INVOKE to the HLR associated with the MS.	1
		2
3-2-10	Start the Authentication Status Report Timer (ASRT).	3
		4
3-2-11	WAIT for an Authentication Status Report response:	5
		6
3-2-12	WHEN a RETURN RESULT is received:	7
3-2-12-1	Stop timer (ASRT).	8
3-2-12-2	IF the message can be processed:	9
		10
3-2-12-2-1	IF the DenyAccess parameter is received:	11
3-2-12-2-1-1	Relay the DenyAccess parameter.	12
		13
3-2-12-2-2	ENDIF.	14
3-2-12-2-3	IF the SSDNotShared (NOSSD) parameter is received:	15
3-2-12-2-3-1	Remove the MS's current SharedSecretData (SSD) and AuthenticationAlgorithmVersion (AAV) from the VLR's database.	16
		17
		18
		19
3-2-12-2-4	ENDIF.	20
3-2-12-2-5	IF the RandomVariableSSD (RANDSSD) is received:	21
3-2-12-2-5-1	IF SharedSecretData (SSD) is shared:	22
3-2-12-2-5-1-1	Remove the MS's current SharedSecretData (SSD) and AuthenticationAlgorithmVersion (AAV) from the VLR's database.	24
		25
		26
3-2-12-2-5-2	ENDIF.	27
		28
3-2-12-2-5-3	Relay the received RandomVariableSSD (RANDSSD) parameter.	29
		30
3-2-12-2-5-4	Mark the MS <i>pending SSD update</i> .	31
		32
3-2-12-2-5-5	IF the SharedSecretData (SSD) is received:	33
3-2-12-2-5-5-1	Store the pending SharedSecretData (SSD) value.	34
		35
3-2-12-2-5-5-2	IF the AuthenticationAlgorithmVersion (AAV) parameter is received:	36
		37
3-2-12-2-5-5-2-1	Store the AuthenticationAlgorithmVersion (AAV) value.	38
		39
		40
3-2-12-2-5-5-3	ENDIF.	41
3-2-12-2-5-5-4	Select a RandomVariableUniqueChallenge (RANDU) and execute CAVE using the value of the pending SharedSecretData (SSD) to produce an AuthenticationResponseUnique (AUTHU).	42
		43
		44
		45
3-2-12-2-5-5-5	Include the RandomVariableUniqueChallenge (RANDU) and AuthenticationResponseUnique (AUTHU) parameters.	46
		47
		48
		49
3-2-12-2-5-5-6	Mark the MS <i>pending Unique Challenge</i> .	50
		51
3-2-12-2-5-6	ELSE (the SharedSecretData (SSD) is not received):	52
3-2-12-2-5-6-1	Relay the RandomVariableUniqueChallenge (RANDU) parameter.	53
		54
3-2-12-2-5-6-2	Relay the AuthenticationResponseUnique (AUTHU) parameter.	55
		56
		57
3-2-12-2-5-6-3	Mark the MS <i>pending Unique Challenge</i> .	58
		59
		60

1 3-2-12-2-5-7 ENDIF.

2 3-2-12-2-6 ELSE (an SSD update is not requested by the AC):

3

4 3-2-12-2-6-1 IF the SharedSecretData (SSD) parameter is received:

5 3-2-12-2-6-1-1 Store the SharedSecretData (SSD) value.

6

7 3-2-12-2-6-1-2 IF the AuthenticationAlgorithmVersion (AAV) parameter

8 is received:

9 3-2-12-2-6-1-2-1 Store the AuthenticationAlgorithmVersion (AAV)

10 value.

11

12 3-2-12-2-6-1-3 ENDIF.

13 3-2-12-2-6-1-4 IF the CallHistoryCount (COUNT) parameter is received:

14 3-2-12-2-6-1-4-1 Store the received CallHistoryCount (COUNT) value.

15

16 3-2-12-2-6-1-5 ENDIF.

17

18 3-2-12-2-6-2 ENDIF.

19 3-2-12-2-6-3 IF the RandomVariableUniqueChallenge (RANDU):

20 3-2-12-2-6-3-1 Relay the received RandomVariableUniqueChallenge

21 (RANDU) and AuthenticationResponseUnique (AUTHU)

22 parameters.

23 3-2-12-2-6-3-2 Mark the MS *pending Unique Challenge*.

24

25 3-2-12-2-6-4 ENDIF.

26

27 3-2-12-2-7 IF the UpdateCount (UPDCOUNT) parameter is received:

28 3-2-12-2-7-1 Relay the received UpdateCount (UPDCOUNT) parameter.

29 3-2-12-2-7-2 Mark the MS *pending COUNT update*.

30

31 3-2-12-2-8 ENDIF.

32 3-2-12-2-9 Send an AuthenticationStatusReport RETURN RESULT to the

33 requesting MSC.

34

35 3-2-12-2-10 IF the MS is marked *pending SSD update*, OR IF the MS is marked

36 *pending Unique Challenge*, OR IF the MS is marked *pending*

37 *COUNT update*:

38 3-2-12-2-10-1 Execute the “VLR Awaiting AuthenticationStatusReport

39 INVOKE” task (see 4.5.2).

40

41 3-2-12-2-11 ENDIF.

42 3-2-12-2-12 Exit this task.

43

44 3-2-12-3 ELSE (the message cannot be processed):

45 3-2-12-3-1 Send a RETURN ERROR to the requesting MSC.

46 3-2-12-3-2 Exit this task.

47

48 3-2-12-4 ENDIF.

49 3-2-13 WHEN a RETURN ERROR or REJECT is received:

50 3-2-13-1 Stop timer (ASRT).

51 3-2-13-2 CASE Error Code OF:

52 3-2-13-3 *ParameterError*:

53 3-2-13-3-1 IF the parameter was originated from the initiating functional entity:

54 3-2-13-3-1-1 Send a RETURN ERROR with the Error Code indicating

55 *ParameterError*.

56

57

58

59

60

3-2-13-3-2	ELSE:	1
3-2-13-3-2-1	Send a RETURN ERROR with the Error Code indicating <i>SystemFailure</i> .	2
		3
		4
3-2-13-3-3	ENDIF.	5
3-2-13-4	<i>OperationSequenceProblem</i> :	6
3-2-13-4-1	Send a RETURN ERROR with the Error Code indicating <i>OperationSequenceProblem</i> .	7
		8
		9
3-2-13-5	<i>DEFAULT</i> :	10
3-2-13-5-1	Send a RETURN ERROR with the Error Code indicating <i>SystemFailure</i> .	11
		12
		13
3-2-13-6	ENDCASE.	14
3-2-13-7	Execute the “Local Recovery Procedures” task (see 3.5.1).	15
		16
3-2-13-8	Exit this task.	17
3-2-14	WHEN timer (ASRT) expires:	18
3-2-14-1	Send a RETURN ERROR with the Error Code indicating <i>SystemFailure</i> .	19
		20
3-2-14-2	Execute the “Local Recovery Procedures ” task (see 3.5.1).	21
		22
3-2-14-3	Exit this task.	23
3-2-15	ENDWAIT.	24
3-3	ELSE (the message cannot be processed):	25
3-3-1	Send a RETURN ERROR to the MSC.	26
3-3-2	IF the MS is marked <i>pending SSD update</i> :	27
3-3-2-1	IF the pending SSD is stored in the VLR’s database:	28
3-3-2-1-1	Remove the pending SharedSecretData (SSD) and AuthenticationAlgorithmVersion (AAV) from the VLR’s database.	29
		30
3-3-2-2	ENDIF.	31
3-3-3	ENDIF.	32
3-3-4	Clear all the MS’s pending operation flags.	33
		34
3-3-5	Execute the “Local Recovery Procedures ” task (see 3.5.1).	35
		36
3-3-6	Exit this task.	37
		38
3-4	ENDIF.	39
4	WHEN timer (ASRRT) expires:	40
4-1	IF the MS is marked <i>pending SSD update</i> :	41
4-1-1	IF the pending SharedSecretData (SSD) is stored in the VLR’s database:	42
4-1-1-1	Remove the pending SharedSecretData (SSD) and AuthenticationAlgorithmVersion (AAV) from the VLR’s database.	43
		44
4-1-2	ENDIF.	45
4-2	ENDIF.	46
4-3	Clear all the MS’s pending operation flags.	47
		48
4-4	Execute the “Local Recovery Procedures ” task (see 3.5.1).	49
		50
5	ENDWAIT.	51
6	Exit this task.	52
		53
		54
		55
		56
		57
		58
		59
		60

Table 11 VLR AuthenticationStatusReport Response

Problem Detection and Recommended Response from VLR to MSC											
PROBLEM DEFINITION	1	2	3	4	5	6	7	8	9	10	Notes
RETURN ERROR Error Code											
<i>UnrecognizedMIN</i>											a
<i>UnrecognizedESN</i>											a
<i>MIN/HLRMismatch</i>						X					e
<i>OperationSequenceProblem</i>											a
<i>ResourceShortage</i>		X									e
<i>OperationNotSupported</i>	X										b, e
<i>TrunkUnavailable</i>											a
<i>ParameterError</i>				X							d
<i>SystemFailure</i>			X								e
<i>UnrecognizedParameterValue</i>					X						d, e
<i>FeatureInactive</i>											a
<i>MissingParameter</i>							X				d, e
RETURN RESULT								X	X	X	c

Problem Detections:

1. The requested MAP operation is recognized, but not supported by the receiving AC (HLR/VLR) or the requesting functional entity is not authorized.
2. A required AC (HLR) resource (e.g., internal memory record, AC (HLR/VLR) is fully occupied) is temporarily not available (e.g., congestion).
3. A required resource (e.g., data base access, functional entity) is not presently accessible due to a failure. Human intervention may be required for resolution.
4. A supplied parameter value an encoding problem (e.g., the supplied MobileIdentificationNumber parameter or Digits (Dialed) parameter digit values do not meet the expected BCD specification).
5. A supplied parameter value is unrecognized or has nonstandard values (e.g., *Not used* , the SystemCapabilities (SYSCAP) parameter indicated authentication is not supported (AUTH is 0), but this AuthenticationStatusReport was received).
6. The supplied MobileIdentificationNumber parameter's AC (HLR) responded that the MIN is not in the AC (HLR)'s range of MIN's or directory numbers (suspect routing error).
7. An optional parameter required by the AC (HLR) was expected, but not received (e.g., a SSD update process was in-progress and a ReportType set to *SSD update successful* was received, but the expected second ReportType parameter indicating the CallHistoryCount's (COUNT's) incrementing status (e.g., *COUNT update successful, COUNT mismatch, Count update no response* etc.) was not received).
8. The supplied MobileIdentificationNumber parameter's AC (HLR) responded that the MIN is within the range of the AC (HLR), but the MIN is not presently assigned to a subscriber. DenyAccess parameter value is *Unspecified*.
9. An AC (HLR) record exists for the supplied MobileIdentificationNumber parameter, but the supplied ElectronicSerialNumber parameter does not match the ESN in the MIN's record. DenyAccess parameter value is *Unspecified*.
10. An AC (HLR) record exists for the supplied MobileIdentificationNumber parameter, but the MIN is either a DelinquentAccount, StolenUnit, DuplicateUnit or Unspecified. DenyAccess parameter value is *Unspecified*.

Notes:

- a. This Error Code is not an appropriate AC (HLR) response to a AuthenticationStatusReport transaction.
- b. It is recommended that an AC (HLR) supports AuthenticationStatusReport transactions.
- c. Only RETURN RESULT operations needing clarification have been included.
- d. Include the *Parameter Identifier* in question as the FaultyParameter parameter.
- e. This response may have been originated by the AC (HLR).

4.5.3 HLR Receiving AuthenticationStatusReport INVOKE

When an HLR receives an AuthenticationStatusReport INVOKE, it shall perform the following:

- 1 IF the received message can be processed:
 - 1-1 Include the SenderIdentificationNumber set to the identification number of the HLR.
 - 1-2 Relay all other received parameters.
 - 1-3 Start the Authentication Status Report Timer (ASRT).
 - 1-4 Send an AuthenticationStatusReport INVOKE to the AC associated with the MS.
 - 1-5 WAIT for an Authentication Status Report response:
 - 1-6 WHEN a RETURN RESULT is received:
 - 1-6-1 Stop timer (ASRT).
 - 1-6-2 IF the message can be processed:
 - 1-6-2-1 Relay all received parameters.
 - 1-6-2-2 Send a RETURN RESULT to the requesting VLR.
 - 1-6-3 ELSE:
 - 1-6-3-1 Send a RETURN ERROR with the Error Code indicating *SystemFailure* to the requesting VLR.
 - 1-6-4 ENDIF.
 - 1-7 WHEN a RETURN ERROR or REJECT is received:
 - 1-7-1 Stop timer (ASRT).
 - 1-7-2 CASE Error Code OF:
 - 1-7-3 *ParameterError*:
 - 1-7-3-1 IF the parameter was originated from the initiating functional entity:
 - 1-7-3-1-1 Send a RETURN ERROR with Error Code set to indicate *ParameterError*.
 - 1-7-3-2 ELSE:
 - 1-7-3-2-1 Send a RETURN ERROR with Error Code set to indicate *SystemFailure*.
 - 1-7-3-3 ENDIF.
 - 1-7-4 *OperationSequenceProblem*:
 - 1-7-4-1 Send a RETURN ERROR with Error Code set to indicate *OperationSequenceProblem*.
 - 1-7-5 *DEFAULT*:
 - 1-7-5-1 Send a RETURN ERROR with Error Code set to indicate *SystemFailure*.

- 1-7-6 ENDCASE.
- 1-7-7 Execute the “Local Recovery Procedures” task (see 3.5.1).
- 1-7-8 Exit this task.
- 1-8 WHEN timer (ASRT) expires:
- 1-8-1 Send a RETURN ERROR with the Error Code indicating *SystemFailure*.
- 1-8-2 Execute the “Local Recovery Procedures ” task (see 3.5.1).
- 1-8-3 Exit this task.
- 1-9 ENDWAIT.
- 2 ELSE (the received message cannot be processed):
- 2-1 Send a RETURN ERROR to the requesting VLR.
- 3 ENDIF.
- 4 Exit this task.

Table 12 HLR AuthenticationStatusReport Response

Problem Detection and Recommended Response from HLR to VLR												
PROBLEM DEFINITION	1	2	3	4	5	6	7	8	9	10	Notes	
RETURN ERROR Error Code												
<i>UnrecognizedMIN</i>											a	
<i>UnrecognizedESN</i>											a	
<i>MIN/HLRMismatch</i>						X					e	
<i>OperationSequenceProblem</i>											a	
<i>ResourceShortage</i>		X									e	
<i>OperationNotSupported</i>	X										b, e	
<i>TrunkUnavailable</i>											a	
<i>ParameterError</i>				X							d	
<i>SystemFailure</i>			X								e	
<i>UnrecognizedParameterValue</i>					X						d, e	
<i>FeatureInactive</i>											a	
<i>MissingParameter</i>							X				d, e	
RETURN RESULT								X	X	X	c	

Problem Detections:

1. The requested MAP operation is recognized, but not supported by the receiving AC (HLR/VLR) or the requesting functional entity is not authorized.
2. A required AC (HLR) resource (e.g., internal memory record, AC (HLR/VLR) is fully occupied) is temporarily not available (e.g., congestion).
3. A required resource (e.g., data base access, functional entity) is not presently accessible due to a failure. Human intervention may be required for resolution.
4. A supplied parameter value an encoding problem (e.g., the supplied MobileIdentificationNumber parameter or Digits (Dialed) parameter digit values do not meet the expected BCD specification).
5. A supplied parameter value is unrecognized or has nonstandard values (e.g., *Not used*, the SystemCapabilities (SYSCAP) parameter indicated authentication is not supported (AUTH is 0), but this AuthenticationStatusReport was received).
6. The supplied MobileIdentificationNumber parameter’s AC (HLR) responded that the MIN is not in the AC (HLR)’s range of MIN’s or directory numbers (suspect routing error).

7. An optional parameter required by the AC (HLR) was expected, but not received (e.g., a SSD update process was in-progress and a ReportType set to *SSD update successful* was received, but the expected second ReportType parameter indicating the CallHistoryCount's (COUNT's) incrementing status (e.g., *COUNT update successful*, *COUNT mismatch*, *Count update no response* etc.) was not received).
8. The supplied MobileIdentificationNumber parameter's AC (HLR) responded that the MIN is within the range of the AC (HLR), but the MIN is not presently assigned to a subscriber. DenyAccess parameter value is *Unspecified*.
9. An AC (HLR) record exists for the supplied MobileIdentificationNumber parameter, but the supplied ElectronicSerialNumber parameter does not match the ESN in the MIN's record. DenyAccess parameter value is *Unspecified*.
10. An AC (HLR) record exists for the supplied MobileIdentificationNumber parameter, but the MIN is either a Delinquent Account, StolenUnit, DuplicateUnit or Unspecified. DenyAccess parameter value is *Unspecified*.

Notes:

- a. This Error Code is not an appropriate AC (HLR) response to a AuthenticationStatusReport transaction.
- b. It is recommended that an AC (HLR) supports AuthenticationStatusReport transactions.
- c. Only RETURN RESULT operations needing clarification have been included.
- d. Include the *Parameter Identifier* in question as the FaultyParameter parameter.
- e. This response may have been originated by the AC (HLR).

4.5.4 AC Awaiting AuthenticationStatusReport INVOKE

When an AC requests the VLR to perform authentication operations that require the VLR to report the outcome, the AC shall perform the following:

- 1 Start the Authentication Status Report Response Timer (ASRRT).
- 2 WAIT for an AuthenticationStatusReport INVOKE:
- 3 WHEN an AuthenticationStatusReport INVOKE is received:
 - 3-1 Stop timer (ASRRT).
 - 3-2 IF the received message can be processed:
 - 3-2-1 Clear all the MS's pending operation flags.
 - 3-2-2 IF the INVOKE reports that SSD updating has been successful:
 - 3-2-2-1 Update the AC's database to indicate that the pending SharedSecretData (SSD) value is now the value used by the MS.
 - 3-2-3 ENDIF.
 - 3-2-4 IF the INVOKE reports that COUNT updating has been successful:
 - 3-2-4-1 Increment the value of COUNT in the AC's database.
 - 3-2-5 ENDIF.
 - 3-2-6 IF an authentication failure has been detected:
 - 3-2-6-1 Execute recovery procedures according to the AC's internal algorithm.
 - 3-2-7 ENDIF.
 - 3-2-8 IF local administrative procedures request that service shall be denied:
 - 3-2-8-1 Include the DenyAccess parameter:
 - 3-2-9 ENDIF.

1 3-2-10 IF SharedSecretData (SSD) presently shared with the VLR shall be
2 discarded:
3
4 3-2-10-1 Include the SSDNotShared (NOSSD) parameter.
5 3-2-11 ENDIF.
6 3-2-12 IF an SSD update shall be initiated:
7
8 3-2-12-1 Select a RandomVariableSSD (RANDSSD) and execute CAVE using
9 the value of the MS's A-key recorded in the AC's database to produce a
10 pending SharedSecretData (SSD).
11 3-2-12-2 Include the RandomVariableSSD (RANDSSD) parameter.
12 3-2-12-3 Mark the MS *pending SSD update*.
13 3-2-12-4 IF AC administrative procedures indicate that the pending
14 SharedSecretData (SSD) shall be shared with the VLR for the SSD
15 update operation:
16
17 3-2-12-4-1 IF the VLR's SystemCapabilities indicates that the VLR is able to
18 execute the CAVE algorithm:
19
20 3-2-12-4-1-1 Include the SharedSecretData (SSD) parameter set to the
21 pending SSD value.
22 3-2-12-4-1-2 IF the AuthenticationAlgorithmVersion (AAV) parameter is
23 received:
24
25 3-2-12-4-1-2-1 Store the AuthenticationAlgorithmVersion (AAV) value.
26 3-2-12-4-1-3 ENDIF.
27 3-2-12-4-2 ENDIF.
28 3-2-12-5 ELSE (pending SharedSecretData (SSD) is not to be shared:
29
30 3-2-12-5-1 Select a RandomVariableUniqueChallenge (RANDU) and execute
31 CAVE using the value of the pending SSD to produce an
32 AuthenticationResponseUnique (AUTHU).
33 3-2-12-5-2 Include the RandomVariableUniqueChallenge (RANDU) and
34 AuthenticationResponseUnique (AUTHU) parameters.
35 3-2-12-5-3 Mark the MS *pending Unique Challenge*.
36 3-2-12-6 ENDIF.
37 3-2-13 ELSE (SSD update not initiated):
38
39 3-2-13-1 IF the SharedSecretData (SSD) shall be shared with the VLR:
40
41 3-2-13-1-1 IF the VLR's SystemCapabilities indicates the VLR is capable of
42 executing the CAVE algorithm:
43
44 3-2-13-1-1-1 Include the SharedSecretData (SSD) and
45 CallHistoryCount(COUNT) parameters.
46 3-2-13-1-1-2 IF the AuthenticationAlgorithmVersion (AAV) parameter is
47 received:
48
49 3-2-13-1-1-2-1 Store the AuthenticationAlgorithmVersion (AAV) value.
50 3-2-13-1-1-3 ENDIF.
51 3-2-13-1-2 ENDIF.
52 3-2-13-2 ENDIF.
53 3-2-13-3 IF a Unique Challenge shall be initiated:
54
55 3-2-13-3-1 Select a RandomVariableUniqueChallenge (RANDU) and execute
56 CAVE using the value of the MS's SharedSecretData (SSD) recorded
57
58
59
60

	in the AC's database to produce an AuthenticationResponseUnique (AUTHU).	1
		2
3-2-13-3-2	Include the RandomVariableUniqueChallenge (RANDU) and AuthenticationResponseUnique (AUTHU) parameters.	3
		4
3-2-13-3-3	Mark the MS <i>pending Unique Challenge</i> .	5
		6
3-2-13-4	ENDIF.	7
		8
3-2-14	ENDIF.	9
		10
3-2-15	IF a COUNT update shall be initiated:	11
3-2-15-1	Include the UpdateCount (UPDCOUNT) parameter.	12
3-2-15-2	Mark the MS <i>pending COUNT update</i> .	13
		14
3-2-16	ENDIF.	15
3-2-17	Send an AuthenticationStatusReport RETURN RESULT to the requesting HLR.	16
		17
3-2-18	IF the MS is marked <i>pending SSD update</i> , OR IF the MS is marked <i>pending Unique Challenge</i> , OR IF the MS is marked <i>pending COUNT update</i> :	18
		19
3-2-18-1	Execute the "AC Awaiting AuthenticationStatusReport INVOKE" task (see 4.5.4).	20
		21
		22
3-2-19	ENDIF.	23
		24
3-2-20	Exit this task.	25
		26
3-3	ELSE (the message cannot be processed):	27
3-3-1	Send a RETURN ERROR to the requesting HLR.	28
		29
3-3-2	IF the MS is marked <i>pending SSD update</i> :	30
3-3-2-1	Remove the pending SharedSecretData (SSD) from the AC's database.	31
		32
3-3-3	ENDIF.	33
		34
3-3-4	Clear all the MS's pending operation flags.	35
		36
3-3-5	Execute the "Local Recovery Procedures" task (see 3.5.1).	37
		38
3-3-6	Exit this task.	39
		40
3-4	ENDIF.	41
		42
4	WHEN timer (ASRRRT) expires:	43
4-1	IF the MS is marked <i>pending SSD update</i> :	44
4-1-1	Remove the pending SharedSecretData (SSD) from the AC's database.	45
		46
4-2	ENDIF.	47
		48
4-3	Clear all the MS's pending operation flags.	49
		50
4-4	Execute the "Local Recovery Procedures" task (see 3.5.1).	51
		52
5	ENDWAIT.	53
		54
6	Exit this task.	55
		56
		57
		58
		59
		60

Table 13 AC AuthenticationStatusReport Response

Problem Detection and Recommended Response from AC to HLR											
PROBLEM DEFINITION	1	2	3	4	5	6	7	8	9	10	Notes
RETURN ERROR Error Code											
<i>UnrecognizedMIN</i>											a
<i>UnrecognizedESN</i>											a
<i>MIN/HLRMismatch</i>						X					e
<i>OperationSequenceProblem</i>											a
<i>ResourceShortage</i>		X									e
<i>OperationNotSupported</i>	X										b, e
<i>TrunkUnavailable</i>											a
<i>ParameterError</i>				X							d
<i>SystemFailure</i>			X								e
<i>UnrecognizedParameterValue</i>					X						d, e
<i>FeatureInactive</i>											a
<i>MissingParameter</i>							X				d, e
RETURN RESULT								X	X	X	c

Problem Detections:

1. The requested MAP operation is recognized, but not supported by the receiving AC (HLR/VLR) or the requesting functional entity is not authorized.
2. A required AC (HLR) resource (e.g., internal memory record, AC (HLR/VLR) is fully occupied) is temporarily not available (e.g., congestion).
3. A required resource (e.g., data base access, functional entity) is not presently accessible due to a failure. Human intervention may be required for resolution.
4. A supplied parameter value an encoding problem (e.g., the supplied MobileIdentificationNumber parameter or Digits (Dialed) parameter digit values do not meet the expected BCD specification).
5. A supplied parameter value is unrecognized or has nonstandard values (e.g., *Not used* , the SystemCapabilities (SYSCAP) parameter indicated authentication is not supported (AUTH is 0), but this AuthenticationStatusReport was received).
6. The supplied MobileIdentificationNumber parameter's AC (HLR) responded that the MIN is not in the AC (HLR)'s range of MIN's or directory numbers (suspect routing error).
7. An optional parameter required by the AC (HLR) was expected, but not received (e.g., a SSD update process was in-progress and a ReportType set to *SSD update successful* was received, but the expected second ReportType parameter indicating the CallHistoryCount's (COUNT's) incrementing status (e.g., *COUNT update successful*, *COUNT mismatch*, *Count update no response*) was not received).
8. The supplied MobileIdentificationNumber parameter's AC (HLR) responded that the MIN is within the range of the AC (HLR), but the MIN is not presently assigned to a subscriber. DenyAccess parameter value is *Unspecified*.
9. An AC (HLR) record exists for the supplied MobileIdentificationNumber parameter, but the supplied ElectronicSerialNumber parameter does not match the ESN in the MIN's record. DenyAccess parameter value is *Unspecified*.
10. An AC (HLR) record exists for the supplied MobileIdentificationNumber parameter, but the MIN is either a DelinquentAccount, StolenUnit, DuplicateUnit or Unspecified. DenyAccess parameter value is *Unspecified*.

Notes:

- a. This Error Code is not an appropriate AC (HLR) response to a AuthenticationStatusReport transaction.
- b. It is recommended that an AC (HLR) supports AuthenticationStatusReport transactions.
- c. Only RETURN RESULT operations needing clarification have been included.
- d. Include the *Parameter Identifier* in question as the FaultyParameter parameter.
- e. This response may have been originated by the AC (HLR).

4.6 BASE STATION CHALLENGE

4.6.1 MSC Initiating a Base Station Challenge

When an MSC receives a Base Station Challenge Order from an MS, it shall perform the following:

- 1 Include the ElectronicSerialNumber parameter set to identify the MS.
- 2 Include the MobileIdentificationNumber parameter set to identify the MS.
- 3 Include the RandomVariableBaseStation (RANDBS) parameter provided by the MS.
- 4 Send a BaseStationChallenge INVOKE to the MSC's associated VLR.
- 5 Start the Base Station Challenge Timer (BSCT).
- 6 WAIT for a Base Station Challenge response:
 - 7 WHEN a RETURN RESULT is received:
 - 7-1 Stop timer (BSCT).
 - 7-2 IF the message can be processed:
 - 7-2-1 Send a Base Station Challenge response to the MS that includes the received AuthenticationResponseBaseStation (AUTHBS).
 - 7-3 ENDIF.
 - 8 WHEN a RETURN ERROR or REJECT is received:
 - 8-1 Stop timer (BSCT).
 - 8-2 Execute the "Local Recovery Procedures" task (see 3.5.1).
 - 9 WHEN timer (BSCT) expires:
 - 9-1 Execute the "Local Recovery Procedures" task (see 3.5.1).
 - 10 ENDWAIT.
 - 11 Exit this task.

4.6.2 VLR Receiving BaseStationChallenge INVOKE

When a VLR receives a BaseStationChallenge INVOKE, it shall perform the following:

- 1 IF the received message can be processed:
 - 1-1 IF the pending SharedSecretData (SSD) was provided to the VLR:
 - 1-1-1 Execute CAVE using the pending SharedSecretData (SSD) of the MS and the RandomVariableBaseStation (RANDBS) provided in the BaseStationChallenge INVOKE to produce the AuthenticationResponseBaseStation (AUTHBS).

- 1 1-1-2 Include the AuthenticationResponseBaseStation (AUTHBS) parameter.
2
3 1-1-3 Send a RETURN RESULT to the requesting MSC.
4
5 1-2 ELSE (SharedSecretData (SSD) is not shared):
6 1-2-1 Include the SenderIdentificationNumber set to the identification number of the
7 VLR.
8 1-2-2 Relay all other received parameters.
9 1-2-3 Send a BaseStationChallenge INVOKE to the HLR associated with the MS.
10 1-2-4 Start the Base Station Challenge Timer (BSCT).
11 1-2-5 WAIT for a Base Station Challenge response:
12 1-2-6 WHEN a RETURN RESULT is received:
13 1-2-6-1 Stop timer (BSCT).
14 1-2-6-2 IF the message can be processed:
15 1-2-6-2-1 Relay all received parameters.
16 1-2-6-2-2 Send the RETURN RESULT to the requesting MSC.
17 1-2-6-2-3 Exit this task.
18 1-2-6-3 ELSE (the message cannot be processed):
19 1-2-6-3-1 Send a RETURN ERROR to the requesting MSC.
20 1-2-6-3-2 Exit this task.
21 1-2-6-4 ENDIF.
22 1-2-7 WHEN a RETURN ERROR or REJECT is received:
23 1-2-7-1 Stop timer (BSCT).
24 1-2-7-2 CASE Error Code OF:
25 1-2-7-3 *ParameterError*:
26 1-2-7-3-1 IF the parameter was originated from the initiating functional entity:
27 1-2-7-3-1-1 Send a RETURN ERROR with the Error Code indicating
28 *ParameterError*.
29 1-2-7-3-2 ELSE:
30 1-2-7-3-2-1 Send a RETURN ERROR with the Error Code indicating
31 *SystemFailure*.
32 1-2-7-3-3 ENDIF.
33 1-2-7-4 *OperationSequenceProblem*:
34 1-2-7-4-1 Send a RETURN ERROR with the Error Code indicating
35 *OperationSequenceProblem*.
36 1-2-7-5 *DEFAULT*:
37 1-2-7-5-1 Send a RETURN ERROR with the Error Code indicating
38 *SystemFailure*.
39 1-2-7-6 ENDCASE.
40 1-2-7-7 Execute the “Local Recovery Procedures” task (see 3.5.1).
41 1-2-7-8 Exit this task.
42 1-2-8 WHEN timer (BSCT) expires:
43 1-2-8-1 Send a RETURN ERROR with Error Code *SystemFailure*.
44 1-2-8-2 Execute “Local Recovery Procedures ” task (see 3.5.1).
45
46
47
48
49
50
51
52
53
54
55
56
57
58
59
60

- 1-2-8-3 Exit this task.
- 1-2-9 ENDWAIT.
- 1-3 ENDIF.
- 2 ELSE (the received message cannot be processed):
- 2-1 Send a RETURN ERROR to the requesting MSC.
- 3 ENDIF.
- 4 Exit this task.

1
2
3
4
5
6
7
8
9
10
11
12
13
14
15
16
17
18
19
20
21
22
23
24
25
26
27
28
29
30
31
32
33
34
35
36
37
38
39
40
41
42
43
44
45
46
47
48
49
50
51
52
53
54
55
56
57
58
59
60

Table 14 VLR BaseStationChallenge Response

Problem Detection and Recommended Response from VLR to an MSC									
PROBLEM DEFINITION	1	2	3	4	5	6	7	8	Notes
RETURN ERROR									
Error Code									
<i>UnrecognizedMIN</i>							X		
<i>UnrecognizedESN</i>								X	
<i>MIN/HLRMismatch</i>					X				d
<i>OperationSequenceProblem</i>						X			d
<i>ResourceShortage</i>		X							d
<i>OperationNotSupported</i>	X								b, d
<i>TrunkUnavailable</i>									a
<i>ParameterError</i>				X					d
<i>SystemFailure</i>			X						d
<i>UnrecognizedParameterValue</i>									a
<i>FeatureInactive</i>									a
<i>MissingParameter</i>									a
RETURN RESULT									c

Problem Detections:

1. The requested MAP operation is recognized, but not supported by the VLR or the requesting functional entity is not authorized.
2. A required VLR resource (e.g., voice channel, internal memory record, VLR is fully occupied) is temporarily not available (e.g., congestion).
3. A required resource (e.g., data base access, functional entity) is not presently accessible due to a failure. Human intervention may be required for resolution.
4. A supplied parameter value has an encoding problem (e.g., The supplied MobileIdentificationNumber parameter digit values do not meet the BCD specification).
5. The supplied MIN's HLR indicated the MobileIdentificationNumber parameter is not in the HLR's range of MINs or Directory Numbers (suspect routing error).
6. The VLR has another Authentication process active for the supplied MobileIdentificationNumber parameter.
7. The VLR does not presently have a record for the supplied MobileIdentificationNumber parameter.
8. The VLR presently has a record for the supplied MobileIdentificationNumber parameter, but the supplied ElectronicSerialNumber parameter does not match the ESN in the MobileIdentificationNumber's record.

Notes:

- a. This Error Code is not an appropriate VLR response to a BaseStationChallenge transaction.
- b. It is recommended that a VLR supports BaseStationChallenge transactions.
- c. Only the RETURN RESULT operations needing clarification have been included.

- d. This response may have been originated by the HLR (AC).

4.6.3 HLR Receiving BaseStationChallenge INVOKE

When an HLR receives a BaseStationChallenge INVOKE, it shall perform the following:

- 1 IF the received message can be processed:
 - 1-1 Include the SenderIdentificationNumber set to the identification number of the HLR.
 - 1-2 Relay all other received parameters.
 - 1-3 Send a BaseStationChallenge INVOKE to the AC associated with the MS.
 - 1-4 Start the Base Station Challenge Timer (BSCT).
 - 1-5 WAIT for a Base Station Challenge response:
 - 1-6 WHEN a RETURN RESULT is received:
 - 1-6-1 Stop timer (BSCT).
 - 1-6-2 IF the message can be processed:
 - 1-6-2-1 Send a RETURN RESULT to the requesting VLR.
 - 1-6-2-2 Exit this task.
 - 1-6-3 ENDIF.
 - 1-7 WHEN a RETURN ERROR or REJECT is received:
 - 1-7-1 Stop timer (BSCT).
 - 1-7-2 CASE Error Code OF:
 - 1-7-3 *ParameterError*:
 - 1-7-3-1 IF the parameter was originated from the initiating functional entity:
 - 1-7-3-1-1 Send a RETURN ERROR with Error Code set to indicate *ParameterError*.
 - 1-7-3-2 ELSE:
 - 1-7-3-2-1 Send a RETURN ERROR with Error Code set to indicate *SystemFailure*.
 - 1-7-3-3 ENDIF.
 - 1-7-4 *OperationSequenceProblem*:
 - 1-7-4-1 Send a RETURN ERROR with Error Code set to indicate *OperationSequenceProblem*.
 - 1-7-5 *DEFAULT*:
 - 1-7-5-1 Send a RETURN ERROR with Error Code set to indicate *SystemFailure*.
 - 1-7-6 ENDCASE.
 - 1-7-7 Execute the “Local Recovery Procedures” task (see 3.5.1).
 - 1-7-8 Exit this task.
 - 1-8 WHEN timer (BSCT) expires:
 - 1-8-1 Send a RETURN ERROR with the Error Code indicating *SystemFailure*.
 - 1-8-2 Execute the “Local Recovery Procedures ” task (see 3.5.1).
 - 1-8-3 Exit this task.
 - 1-9 ENDWAIT.

- 2 ELSE (the received message cannot be processed):
- 2-1 Send a RETURN ERROR to the requesting VLR.
- 3 ENDIF.
- 4 Exit this task.

Table 15 HLR BaseStationChallenge Response

Problem Detection and Recommended Response from HLR to a VLR								
PROBLEM DEFINITION	1	2	3	4	5	6	7	Notes
RETURN ERROR Error Code								
<i>UnrecognizedMIN</i>						X		
<i>UnrecognizedESN</i>							X	
<i>MIN/HLRMismatch</i>					X			d
<i>OperationSequenceProblem</i>								d
<i>ResourceShortage</i>		X						d
<i>OperationNotSupported</i>	X							b, d
<i>TrunkUnavailable</i>								a
<i>ParameterError</i>				X				d
<i>SystemFailure</i>			X					d
<i>UnrecognizedParameterValue</i>								a
<i>FeatureInactive</i>								a
<i>MissingParameter</i>								a
RETURN RESULT								c

Problem Detections:

1. The requested MAP operation is recognized, but not supported by the HLR or the requesting functional entity is not authorized.
2. A required HLR resource (e.g., voice channel, internal memory record, HLR is fully occupied) is temporarily not available (e.g., congestion).
3. A required resource (e.g., data base access, functional entity) is not presently accessible due to a failure. Human intervention may be required for resolution.
4. A supplied parameter value has an encoding problem (e.g., The supplied MobileIdentificationNumber parameter digit values do not meet the BCD specification).
5. The supplied MobileIdentificationNumber parameter is not in the HLR's range of MINs or Directory Numbers (suspect routing error).
6. The HLR does not presently have a record for the supplied MobileIdentificationNumber parameter.
7. The HLR presently has a record for the supplied MobileIdentificationNumber parameter, but the supplied ElectronicSerialNumber parameter does not match the ESN in the MIN's record.

Notes:

- a. This Error Code is not an appropriate HLR response to a BaseStationChallenge transaction.
- b. It is recommended that a HLR supports BaseStationChallenge transactions.
- c. Only the RETURN RESULT operations needing clarification have been included.
- d. This response may have been originated by the AC.

4.6.4 AC Receiving BaseStationChallenge INVOKE

When an AC receives a BaseStationChallenge INVOKE, it shall perform the following:

- 1 IF the received message can be processed:

- 1-1 Execute CAVE using the pending SSD of the MS and the RandomVariableBaseStation (RANDBS) provided in the BaseStationChallenge INVOKE, to produce the AuthenticationResponseBaseStation (AUTHBS).
- 1-2 Include the AuthenticationResponseBaseStation (AUTHBS) parameter.
- 1-3 Send a RETURN RESULT to the requesting HLR.
- 2 ELSE (the received message cannot be processed):
- 2-1 Send a RETURN ERROR to the requesting HLR.
- 3 ENDIF.
- 4 Exit this task.

Table 16 AC BaseStationChallenge Response

Problem Detection and Recommended Response from AC to a HLR									
PROBLEM DEFINITION	1	2	3	4	5	6	7	8	Notes
RETURN ERROR Error Code									
<i>UnrecognizedMIN</i>							X		
<i>UnrecognizedESN</i>								X	
<i>MIN/HLRMismatch</i>					X				
<i>OperationSequenceProblem</i>						X			
<i>ResourceShortage</i>		X							
<i>OperationNotSupported</i>	X								b
<i>TrunkUnavailable</i>									a
<i>ParameterError</i>				X					
<i>SystemFailure</i>			X						
<i>UnrecognizedParameterValue</i>									a
<i>FeatureInactive</i>									a
<i>MissingParameter</i>									a
RETURN RESULT									c

Problem Detections:

- The requested MAP operation is recognized, but not supported by the AC or the requesting functional entity is not authorized.
- A required AC resource (e.g., voice channel, internal memory record, AC is fully occupied) is temporarily not available (e.g., congestion).
- A required resource (e.g., data base access, functional entity) is not presently accessible due to a failure. Human intervention may be required for resolution.
- A supplied parameter value has an encoding problem (e.g., The supplied MobileIdentificationNumber parameter digit values do not meet the BCD specification).
- The supplied MobileIdentificationNumber parameter is not in the AC's range of MINs or Directory Numbers (suspect routing error).
- The AC has another Authentication process active for the supplied MobileIdentificationNumber parameter.
- The AC does not presently have a record for the supplied MobileIdentificationNumber parameter.
- The AC presently has a record for the supplied MobileIdentificationNumber parameter, but the supplied ElectronicSerialNumber parameter does not match the ESN in the MIN's record.

Notes:

- This Error Code is not an appropriate AC response to a BaseStationChallenge transaction.
- It is recommended that an AC supports BaseStationChallenge transactions.

- c. Only the RETURN RESULT operations needing clarification have been included.

4.7 BLOCKING

See Chapter 4 for the Blocking procedures.

4.8 BULK DEREGISTRATION

4.8.1 VLR Initiating a Bulk Deregistration

When internal VLR procedures indicate that all MS records associated with an HLR shall be freed, the VLR shall perform the following:

- 1 Include the SenderIdentificationNumber set to the identification number of the VLR.
- 2 Remove the MS records.
- 3 Send a BulkDeregistration INVOKE to the MS's HLR.
- 4 Start the Bulk Deregistration Timer (BDT).
- 5 WAIT for an Bulk Deregistration response:
- 6 WHEN a RETURN RESULT is received:
 - 6-1 Stop timer (BDT).
 - 6-2 IF the message cannot be processed:
 - 6-2-1 Execute "Local Recovery Procedures" task (see 3.5.1).
 - 6-3 ENDIF.
- 7 WHEN a RETURN ERROR or REJECT is received:
 - 7-1 Stop timer (BDT).
 - 7-2 Execute "Local Recovery Procedures " task (see 3.5.1).
- 8 WHEN timer (BDT) expires:
 - 8-1 Execute "Local Recovery Procedures " task (see 3.5.1).
- 9 ENDWAIT.
- 10 Exit this task.

4.8.2 HLR Receiving BulkDeregistration INVOKE

When an HLR receives a BulkDeregistration INVOKE, it shall perform the following:

- 1 IF the received message can be processed:
 - 1-1 Send a RETURN RESULT to the requesting VLR.
 - 1-2 Clear the location pointer of those MSs that were registered in the requesting VLR.
- 2 ELSE (the received message cannot be processed):
 - 2-1 Send a RETURN ERROR with a proper Error Code value (see the following table) to the requesting VLR.
- 3 ENDIF.
- 4 Exit this task.

Table 17 HLR BulkDeregistration Response

Problem Detection and Recommended Response from HLR to VLR					
PROBLEM DEFINITION	1	2	3	4	Notes
RETURN ERROR Error Code					
<i>UnrecognizedMIN</i>					a
<i>UnrecognizedESN</i>					a
<i>MIN/HLRMismatch</i>					a
<i>OperationSequenceProblem</i>					a
<i>ResourceShortage</i>		X			
<i>OperationNotSupported</i>	X				b
<i>TrunkUnavailable</i>					a
<i>ParameterError</i>					a
<i>SystemFailure</i>			X		
<i>UnrecognizedParameterValue</i>				X	d
<i>FeatureInactive</i>					a
<i>MissingParameter</i>					a
RETURN RESULT					c

Problem Detections:

1. The requested MAP operation is recognized, but not supported by the receiving HLR or the requesting functional entity is not authorized.
2. A required HLR resource (e.g., subscriber database) is temporarily not available (e.g., congestion).
3. A required resource is not available due to a failure. Human intervention may be required for resolution.
4. A supplied parameter value is unrecognized or has a nonstandard values.

Notes:

- a. This Error Code is not an appropriate HLR response to a BulkDeregistration transaction.
- b. It is recommended that an HLR supports BulkDeregistration transactions.
- c. Only RETURN RESULT operations needing clarification have been included.
- d. Include the *Parameter Identifier* in question as the FaultyParameter parameter.

4.10 COUNT REQUEST

4.10.1 AC Initiating a Count Request

When an AC determines that it needs to retrieve the current value of the CallHistoryCount (COUNT) parameter from the current serving system, it shall perform the following:

- 1 Include the ElectronicSerialNumber parameter set to identify the MS.
- 2 Include the MobileIdentificationNumber parameter set to identify the MS.
- 3 Send a CountRequest INVOKE to the MS's associated HLR.
- 4 Start the Count Request Timer (CRT).
- 5 WAIT for a Count Request response:
- 6 WHEN a RETURN RESULT is received:
 - 6-1 Stop timer (CRT).

- 6-2 IF the message can be processed: 1
- 6-2-1 IF the CallHistoryCount (COUNT) parameter was not received: 2
- 6-2-1-1 Execute the “Local Recovery Procedures” task (see 3.5.1). 3
- 6-2-2 ENDIF. 4
- 6-3 ENDIF. 5
- 7 WHEN a RETURN ERROR or REJECT is received: 6
- 7-1 Stop timer (CRT). 7
- 7-2 Execute “Local Recovery Procedures ” task (see 3.5.1). 8
- 8 WHEN timer (CRT) expires: 9
- 8-1 Execute “Local Recovery Procedures ” task (see 3.5.1). 10
- 9 ENDWAIT. 11
- 10 Exit this task. 12

4.10.2 HLR Receiving CountRequest INVOKE

When an HLR receives a CountRequest INVOKE, it shall perform the following:

- 1 IF the received message can be processed: 21
- 1-1 IF the CallHistoryCount (COUNT) cannot be retrieved for the indicated MS: 22
- 1-1-1 Send a CountRequest RETURN RESULT to the requesting AC (without the 23
- CallHistoryCount (COUNT) parameter). 24
- 1-1-2 Exit this task. 25
- 1-2 ENDIF. 26
- 1-3 Include the SenderIdentificationNumber set to the identification number of the 27
- HLR. 28
- 1-4 Relay all other received parameters. 29
- 1-5 Send a CountRequest INVOKE to the VLR where the MS is currently registered. 30
- 1-6 Start the Count Request Timer (CRT). 31
- 1-7 WAIT for a Count Request response: 32
- 1-8 WHEN a RETURN RESULT is received: 33
- 1-8-1 Stop timer (CRT). 34
- 1-8-2 IF the message can be processed: 35
- 1-8-2-1 Relay all received parameters. 36
- 1-8-2-2 Send a RETURN RESULT to the requesting AC. 37
- 1-8-2-3 Exit this task. 38
- 1-8-3 ELSE (the message cannot be processed): 39
- 1-8-3-1 Send a RETURN ERROR to the requesting AC. 40
- 1-8-3-2 Exit this task. 41
- 1-8-4 ENDIF. 42
- 1-9 WHEN a RETURN ERROR or REJECT is received: 43
- 1-9-1 Stop timer (CRT). 44
- 1-9-2 CASE Error Code OF: 45
- 1-9-3 *ParameterError*: 46

1
2
3
4
5
6
7
8
9
10
11
12
13
14
15
16
17
18
19
20
21
22
23
24
25
26
27
28
29
30
31
32
33
34
35
36
37
38
39
40
41
42
43
44
45
46
47
48
49
50
51
52
53
54
55
56
57
58
59
60

1-9-3-1 IF the parameter was originated from the initiating functional entity:
1-9-3-1-1 Send a RETURN ERROR with Error Code set to indicate *ParameterError*.
1-9-3-2 ELSE:
1-9-3-2-1 Send a RETURN ERROR with Error Code set to indicate *SystemFailure*.
1-9-3-3 ENDIF.
1-9-4 *OperationSequenceProblem*:
1-9-4-1 Send a RETURN ERROR with Error Code set to indicate *OperationSequenceProblem*.
1-9-5 *DEFAULT*:
1-9-5-1 Send a RETURN ERROR with Error Code set to indicate *SystemFailure*.
1-9-6 ENDCASE.
1-9-7 Execute the “Local Recovery Procedures” task (see 3.5.1).
1-9-8 Exit this task.
1-10 WHEN timer (CRT) expires:
1-10-1 Send a RETURN ERROR with the Error Code indicating *SystemFailure*, to the requesting AC.
1-10-2 Execute the “Local Recovery Procedures ” task (see 3.5.1).
1-10-3 Exit this task.
1-11 ENDWAIT.
2 ELSE (the received message cannot be processed):
2-1 Send a RETURN ERROR to the requesting AC.
3 ENDIF.
4 Exit this task.

Table 18 HLR CountRequest Response

Problem Detection and Recommended Response from HLR to AC								
PROBLEM DEFINITION	1	2	3	4	5	6	7	Notes
RETURN ERROR Error Code								
<i>UnrecognizedMIN</i>						X		
<i>UnrecognizedESN</i>							X	
<i>MIN/HLRMismatch</i>					X			a
<i>OperationSequenceProblem</i>								d
<i>ResourceShortage</i>		X						
<i>OperationNotSupported</i>	X							b
<i>TrunkUnavailable</i>								a
<i>ParameterError</i>				X				
<i>SystemFailure</i>			X					
<i>UnrecognizedParameterValue</i>								a
<i>FeatureInactive</i>								a
<i>MissingParameter</i>								a
RETURN RESULT								c

Problem Detections:

1. The requested MAP operation is recognized, but not supported by the HLR or the requesting functional entity is not authorized.
2. A required HLR resource (e.g., voice channel, internal memory record, HLR is fully occupied) is temporarily not available (e.g., congestion).
3. A required resource (e.g., data base access, functional entity) is not presently accessible due to a failure. Human intervention may be required for resolution.
4. A supplied parameter value has an encoding problem (e.g., The supplied MobileIdentificationNumber parameter digit values do not meet the BCD specification).
5. The supplied MobileIdentificationNumber parameter is not in the HLR's range of MINs or Directory Numbers (suspect routing error).
6. The HLR does not presently have a record for the supplied MobileIdentificationNumber parameter.
7. The HLR presently has a record for the supplied MobileIdentificationNumber parameter, but the supplied ElectronicSerialNumber parameter does not match the ESN in the MIN's record.

Notes:

- a. This Error Code is not an appropriate HLR response to a CountRequest transaction.
- b. It is recommended that a HLR supports CountRequest transactions.
- c. Only the RETURN RESULT operations needing clarification have been included.
- d. This response may have been originated by the VLR.

4.10.3 VLR Receiving Count Request INVOKE

When a VLR receives a CountRequest INVOKE, it shall perform the following:

- 1 IF the received message can be processed:
 - 1-1 Include CallHistoryCount (COUNT) parameter set to the current stored value.
 - 1-2 Send a RETURN RESULT to the requesting HLR.
- 2 ELSE (the received message cannot be processed):
 - 2-1 Send a RETURN ERROR to the requesting HLR.

- 3 ENDIF.
4 Exit this task.

Table 19 VLR CountRequest Response

Problem Detection and Recommended Response from VLR to HLR								
PROBLEM DEFINITION	1	2	3	4	5	6	7	Notes
RETURN ERROR Error Code								
<i>UnrecognizedMIN</i>					X			
<i>UnrecognizedESN</i>						X		
<i>MIN/HLRMismatch</i>								a
<i>OperationSequenceProblem</i>							X	
<i>ResourceShortage</i>		X						
<i>OperationNotSupported</i>	X							b
<i>TrunkUnavailable</i>								a
<i>ParameterError</i>				X				
<i>SystemFailure</i>			X					
<i>UnrecognizedParameterValue</i>								a
<i>FeatureInactive</i>								a
<i>MissingParameter</i>								a
RETURN RESULT								c

Problem Detections:

1. The requested MAP operation is recognized, but not supported by the VLR or the requesting functional entity is not authorized.
2. A required VLR resource (e.g., voice channel, internal memory record, VLR is fully occupied) is temporarily not available (e.g., congestion).
3. A required resource (e.g., data base access, functional entity) is not presently accessible due to a failure. Human intervention may be required for resolution.
4. A supplied parameter value has an encoding problem (e.g., The supplied MobileIdentificationNumber parameter digit values do not meet the BCD specification).
5. The VLR does not presently have a record for the supplied MobileIdentificationNumber parameter.
6. The VLR presently has a record for the supplied MobileIdentificationNumber parameter, but the supplied ElectronicSerialNumber parameter does not match the ESN in the MIN's record.
7. The VLR has a record for the supplied MobileIdentificationNumber and ElectronicSerialNumber parameters, but the VLR does not have the SharedSecretData (SSD).

Notes:

- a. This Error Code is not an appropriate VLR response to a CountRequest transaction.
- b. It is recommended that a VLR supports CountRequest transactions.
- c. Only the RETURN RESULT operations needing clarification have been included.

4.11 FACILITIES DIRECTIVE (HANDOFF FORWARD)

The handoff forward using the FacilitiesDirective operation is described in this section.

4.11.1 Serving MSC Initiating a Facilities Directive

When a Serving MSC determines that it needs to handoff a call to a Target MSC, it shall do the following:

- 1 IF handoff is allowed (e.g., InterSwitchCount value at the Serving MSC is less than *MAXHANDOFF*, see 2.1):
 - 1-1 IF the Serving MSC is also the Anchor MSC.
 - 1-1-1 IF the MS being handed off is alerting:
 - 1-1-1-1 IF the Target MSC is known to support handoff while alerting:
 - 1-1-1-1-1 Include the HandoffState parameter set to *Terminator is handingoff*.
 - 1-1-1-1-2 ELSE:
 - 1-1-1-1-2-1 Optionally, attempt to select another target according to internal algorithms.
 - 1-1-1-1-2-2 Exit this task.
 - 1-1-1-1-3 ENDIF.
 - 1-1-2 ELSEIF the MS is awaiting an answer AND IF answer supervision is provided for handed-off MSs:
 - 1-1-2-1 IF the Target MSC is known to support handoff while awaiting an answer:
 - 1-1-2-1-1 Include the HandoffState parameter set to *Originator is handingoff*.
 - 1-1-2-2 ELSE:
 - 1-1-2-2-1 Optionally, attempt to select another target according to internal algorithms.
 - 1-1-2-2-2 Exit this task.
 - 1-1-2-3 ENDIF.
 - 1-1-3 ENDIF.
 - 1-2 ENDIF.
 - 1-3 IF an inter-MSC trunk is available to the Target MSC:
 - 1-3-1 Allocate an inter-MSC trunk:
 - 1-3-2 IF the SignalingMessageEncryptionKey (SMEKEY) parameter is available:
 - 1-3-2-1 Include the SignalingMessageEncryptionKey (SMEKEY) parameter.
 - 1-3-2-2 Include the ConfidentialityModes (CMODES-desired) parameter set according to the MS's Signaling Message Encryption mode.
 - 1-3-3 ENDIF.
 - 1-3-4 IF the subscriber is authorized to have Voice Privacy:
 - 1-3-4-1 IF the MS supports TDMA:
 - 1-3-4-1-1 IF the VoicePrivacyMask (VPMASK) is available:
 - 1-3-4-1-1-1 Include the VoicePrivacyMask (VPMASK) parameter.
 - 1-3-4-1-2 ENDIF.
 - 1-3-4-2 ENDIF.
 - 1-3-4-3 IF the MS supports CDMA (FacilitiesDirective2 only):
 - 1-3-4-3-1 IF the CDMAPrivateLongCodeMask (CDMAPLCM) is available:

1 1-3-4-3-1-1 Include the CDMAPrivateLongCodeMask (CDMAPLCM)
2 parameter.
3
4 1-3-4-3-1-2 Include the CDMAChannelData parameter with the Long Code
5 Mask field set to the long code mask in use at the Serving MSC.
6
7 1-3-4-3-2 ENDIF.
8
9 1-3-4-4 ENDIF.
10
11 1-3-4-5 IF ConfidentialityModes (CMODES-desired) parameter has not been
12 received:
13 1-3-4-5-1 Include the ConfidentialityModes (CMODES-desired) parameter.
14
15 1-3-4-6 ENDIF.
16
17 1-3-4-7 Set the Voice Privacy field of the ConfidentialityModes (CMODES-
18 desired) parameter according to the MS's preferred Voice Privacy mode.
19
20 1-3-5 ENDIF.
21
22 1-3-6 IF the Serving MSC is the Anchor MSC:
23 1-3-6-1 Include the InterSwitchCount parameter set to 1.
24 1-3-6-2 IF this is the first handoff segment:
25 1-3-6-2-1 Include the BillingID parameter with the value of the
26 SegmentCounter field set to 0 (associated with the air segment on this
27 MSC).
28 1-3-6-3 ELSE (this is not the first handoff segment):
29 1-3-6-3-1 Include the BillingID parameter with the value of the
30 SegmentCounter field set to the value of the stored BillingID
31 parameter.
32 1-3-6-4 ENDIF.
33 1-3-7 ELSE (the Serving MSC is not the Anchor MSC):
34 1-3-7-1 Include the InterSwitchCount parameter set to the value of the stored
35 InterSwitchCount incremented by 1.
36 1-3-7-2 Include the BillingID parameter with the value of the Segment Counter
37 field set to the value of the stored BillingID parameter.
38 1-3-8 ENDIF.
39 1-3-9 IF the Serving MSC counts tandem segments:
40 1-3-9-1 IF the value of the BillingID parameter Segment Counter field is not
41 FF₁₆:
42 1-3-9-1-1 Increment the value of the BillingID parameter Segment Counter
43 field by 1 (the value to be associated with the tandem segment being
44 created).
45 1-3-9-2 ENDIF.
46
47 1-3-10 ENDIF.
48
49 1-3-11 CASE the currently assigned voice or traffic channel mode OF:
50 1-3-12 AMPS:
51 1-3-12-1 Include the ChannelData parameter.
52 1-3-12-2 Include the TargetCellID parameter.
53 1-3-13 NAMPS (FacilitiesDirective2 only):
54 1-3-13-1 Include the NAMPSCallMode parameter.
55
56
57
58
59
60

1-3-13-2	Include the ChannelData parameter.	1
1-3-13-3	Include the NAMPSChannelData parameter.	2
1-3-13-4	Include the TargetCellID parameter.	3
1-3-14	CDMA (FacilitiesDirective2 only):	4
1-3-14-1	Include the CDMACallMode parameter.	5
1-3-14-2	Include the CDMAChannelData parameter.	6
1-3-14-3	Include the CDMA MobileProtocolRevision parameter.	7
1-3-14-4	Include the CDMA ServingOneWayDelay parameter.	8
1-3-14-5	Include the CDMA StationClassMark parameter.	9
1-3-14-6	Include the MSLocation parameter.	10
1-3-14-7	IF the handoff was mobile assisted:	11
1-3-14-7-1	Include the CDMA TargetMAHOList parameter including one or more CDMA TargetMAHOInformation parameters.	12
1-3-14-8	ELSE (handoff was not mobile assisted):	13
1-3-14-8-1	Include the CDMA TargetMeasurementList parameter including one or more CDMA TargetMeasurementInformation parameters.	14
1-3-14-9	ENDIF.	15
1-3-15	TDMA:	16
1-3-15-1	Include the TDMA CallMode parameter.	17
1-3-15-2	Include the TDMA ChannelData parameter.	18
1-3-15-3	Include the TargetCellID parameter.	19
1-3-15-4	IF applicable:	20
1-3-15-4-1	Include the TDMA BurstIndicator.	21
1-3-15-5	ENDIF.	22
1-3-16	ENDCASE.	23
1-3-17	Include the ElectronicSerialNumber parameter set to identify the MS.	24
1-3-18	Include the MobileIdentificationNumber parameter set to identify the MS.	25
1-3-19	Include the ServingCellID parameter set to the cell currently serving the MS.	26
1-3-20	Send a FACDIR (FacilitiesDirective or FacilitiesDirective2) INVOKE to the Target MSC.	27
1-3-21	Start the Handoff Order Timer (HOT).	28
1-3-22	WAIT for the Facilities Directive response:	29
1-3-23	WHEN a RETURN RESULT is received:	30
1-3-23-1	Stop timer (HOT).	31
1-3-23-2	IF the message can be processed:	32
1-3-23-2-1	IF required:	33
1-3-23-2-1-1	Order the MS to conform to the Target MSC's selected voice or traffic channel and associated transmission modes (e.g., as indicated by the parameters ChannelData, NAMPSChannelData, TDMAChannelData, CDMAChannelData).	34
1-3-23-2-2	ENDIF.	35
1-3-23-2-3	IF the ConfidentialityModes (CMODES-Actual) parameter is provided:	36
		37
		38
		39
		40
		41
		42
		43
		44
		45
		46
		47
		48
		49
		50
		51
		52
		53
		54
		55
		56
		57
		58
		59
		60

1 1-3-23-2-3-1 Order the MS to handoff with Voice Privacy and
2 SignalingMessage Encryption modes enabled as requested.
3
4 1-3-23-2-4 ELSE:
5 1-3-23-2-4-1 Order the MS to handoff with Voice Privacy and
6 SignalingMessage Encryption disabled.
7
8 1-3-23-2-5 ENDIF.
9 1-3-23-2-6 Start the Mobile Handoff Order Timer (MHOT).
10 1-3-23-2-7 WAIT for the MS to get on channel:
11
12 1-3-23-2-8 WHEN a MobileOnChannel INVOKE is received:
13 1-3-23-2-8-1 Stop timer (MHOT).
14 1-3-23-2-8-2 Connect the call path to the inter-MS trunk.
15 1-3-23-2-8-3 IF the MS being handed off is alerting AND IF the HandoffState
16 parameter was received AND IF its value is *Terminator is*
17 *handing off*:
18
19 1-3-23-2-8-3-1 Execute the “MSC Awaiting InterSystemAnswer” task (see
20 4.24.1).
21 1-3-23-2-8-3-2 IF the handoff trunk is still seized:
22 1-3-23-2-8-3-2-1 Provide answer supervision to the incoming call leg.
23
24 1-3-23-2-8-3-3 ENDIF.
25 1-3-23-2-8-4 ELSEIF the MS is awaiting an answer AND IF answer
26 supervision is provided for handed-off MSs AND IF the
27 HandoffState parameter was received AND IF its value is
28 *Originator is handing off*:
29
30 1-3-23-2-8-4-1 Start an alerting timer (if its not already started).
31 1-3-23-2-8-4-2 WAIT for originating leg to answer:
32 1-3-23-2-8-4-3 WHEN the originating leg answers:
33 1-3-23-2-8-4-3-1 Stop the alerting timer.
34 1-3-23-2-8-4-3-2 GOTO the “MSC Initiating InterSystemAnswer” task
35 (see 4.24.2).
36 1-3-23-2-8-4-4 WHEN a FacilitiesRelease INVOKE is received (see
37 4.13.2):
38 1-3-23-2-8-4-4-1 Stop the alerting timer.
39 1-3-23-2-8-4-4-2 Exit this task.
40
41 1-3-23-2-8-4-5 WHEN the alerting timer expires:
42 1-3-23-2-8-4-5-1 Execute the “MSC Initiation of Facilities Release” task
43 (see 4.13.1).
44 1-3-23-2-8-4-5-2 Exit this task.
45 1-3-23-2-8-4-5-3 (HandoffBack is allowed here and the HandoffState
46 parameter should be received.)
47
48 1-3-23-2-8-4-6 ENDWAIT.
49 1-3-23-2-8-5 ENDIF.
50 1-3-23-2-9 WHEN the (MHOT) timer expires:
51
52 1-3-23-2-9-1 Execute the “MSC Initiation of Facilities Release” task (see
53 4.13.1) to release the associated inter-MS facilities.
54
55
56
57
58
59
60

1-3-23-2-9-2	Execute “Local Recovery Procedures” task (see 3.5.1).	1
1-3-23-2-10	WHEN a FacilitiesRelease INVOKE is received for the inter-MS facilities (call abandonment, see 4.13.2):	2
1-3-23-2-10-1	Stop timer (MHOT).	3
1-3-23-2-10-2	Execute the “MSC Initiation of Facilities Release” task (see 4.13.1) to release the associated inter-MS facilities toward the Target MSC.	4
1-3-23-2-10-3	Execute “Local Recovery Procedures ” task (see 3.5.1).	5
1-3-23-2-11	ENDWAIT.	6
1-3-23-3	ELSE (the message can be processed):	7
1-3-23-3-1	Execute the “MSC Initiation of Facilities Release ” task (see 4.13.1) to release the associated inter-MS facilities.	8
1-3-23-3-2	Execute “Local Recovery Procedures ” task (see 3.5.1).	9
1-3-23-4	ENDIF.	10
1-3-24	WHEN a INVOKE is received for the inter-MS facilities (call abandonment, see 4.13.2):	11
1-3-24-1	Spawn the “MSC Initiation of Facilities Release ” task (see 4.13.1) to release the associated inter-MS facilities toward the Target MSC.	12
1-3-24-2	Remain in this state (to wait for a response).	13
1-3-25	WHEN a RETURN ERROR or REJECT is received:	14
1-3-25-1	Stop timer (HOT).	15
1-3-25-2	Execute the “MSC Initiation of Facilities Release ” task (see 4.13.1) to release the associated inter-MS facilities.	16
1-3-25-3	Execute “Local Recovery Procedures ” task (see 3.5.1).	17
1-3-26	WHEN the (HOT) timer expires:	18
1-3-26-1	Execute the “MSC Initiation of Facilities Release ” task (see 4.13.1) to release the associated inter-MS facilities.	19
1-3-26-2	Execute “Local Recovery Procedures ” task (see 3.5.1).	20
1-3-27	ENDWAIT.	21
1-4	ELSE (handoff is not allowed):	22
1-4-1	Attempt to select another target according to internal algorithms.	23
1-5	ENDIF.	24
2	ENDIF.	25
3	Exit this task.	26

4.11.2 Target MSC Receiving a FacilitiesDirective INVOKE

When the Target MSC receives a FACDIR (FacilitiesDirective or FacilitiesDirective2) INVOKE, the MSC shall do the following:

- 1 IF the received message can be processed:
 - 1-1 IF InterSwitchCount value at the Target MSC is greater than or equal to *MAXHANDOFF* (see 2.1):
 - 1-1-1 Send a RETURN ERROR with Error Code *OperationSequenceProblem*.
 - 1-2 ENDIF.

- 1 1-3 Identify the target voice or traffic channel and associated transmission modes
2 based upon the received ChannelData, NAMPSChannelData, TDMACHannelData,
3 and CDMAChannelData,, parameters.
4
- 5 1-4 IF voice/traffic channels are available on any of the designated cell(s):
6 1-4-1 IF the Segment Counter field value in the received BillingID parameter is
7 FF₁₆ (indicating *Unspecified*):
8 1-4-1-1 Do not change the value.
9 1-4-2 ELSE:
10 1-4-2-1 Increment the Segment Counter field value in the received BillingID
11 parameter by 1 (to be associated with the air segment being created).
12 1-4-3 ENDIF.
13 1-4-4 Use the updated BillingID parameter for the new call segment.
14 1-4-5 CASE the target voice or traffic channel mode OF:
15 1-4-6 AMPS:
16 1-4-6-1 Include the ChannelData parameter.
17 1-4-7 NAMPS (FacilitiesDirective2 only):
18 1-4-7-1 Include the ChannelData parameter.
19 1-4-7-2 Include the NAMPSChannelData parameter.
20 1-4-8 CDMA (FacilitiesDirective2 only):
21 1-4-8-1 Include the CDMAChannelData parameter.
22 1-4-8-2 Include the CDMACodeChannelList parameter including
23 CDMACodeChannelInformation parameters including a TargetCellID
24 parameter and a CDMACodeChannel parameter.
25 1-4-8-3 Include the CDMASearchWindow parameter.
26 1-4-8-4 Include the ConfidentialityModes (CMODES-Actual) parameter.
27 1-4-8-5 Set the actual Signaling Message Encryption field of the
28 ConfidentialityModes (CMODES-Actual) parameter based on the
29 presence of the SignalingMessageEncryptionKey (SMEKEY) parameter
30 and the Target MSC preferences.
31 1-4-8-6 Set the actual Voice Privacy field of the
32 ConfidentialityModes(CMODES-Actual) parameter based on the
33 presence of the CDMAPrivateLongCodeMask (CDMAPLCM) parameter,
34 the desired state (as indicated by the ConfidentialityModes (CMODES-
35 desired) parameter), and the capabilities of the allocated channel(s).
36 1-4-9 TDMA:
37 1-4-9-1 Include the TDMACHannelData parameter.
38 1-4-9-2 Include the ConfidentialityModes (CMODES-Actual) parameter.
39 1-4-9-3 IF applicable:
40 1-4-9-3-1 Include the TDMABurstIndicator parameter.
41 1-4-9-4 ENDIF.
42 1-4-9-5 Set the actual Signaling Message Encryption field of the
43 ConfidentialityModes (CMODES-Actual) parameter based on the
44 presence of the SignalingMessageEncryptionKey (SMEKEY) parameter
45 and the Target MSC preferences.
46
47
48
49
50
51
52
53
54
55
56
57
58
59
60

- 1-4-9-6 Set the actual Voice Privacy field of the ConfidentialityModes(CMODES-Actual) parameter based on the presence of the VoicePrivacyMask (VPMASK), the desired state (as indicated by the ConfidentialityModes (CMODES-desired) parameter), and the capabilities of the allocated channel(s).
- 1-4-10 ENDCASE.
- 1-4-11 Send a RETURN RESULT.
- 1-4-12 Execute the “Target MSC Handoff Forward” task (see 4.11.3).
- 1-5 ELSE (there are no voice/traffic channels available on the designated cell(s)):
 - 1-5-1 Send a RETURN ERROR with Error Code *ResourceShortage*.
- 1-6 ENDIF.
- 2 ELSE (the received message cannot be processed):
 - 2-1 Send a RETURN ERROR with the proper Error Code value (see the following table).
 - 3 ENDIF.
 - 4 Exit this task.

Table 20 Target MSC FacilitiesDirective Response

Problem Detection and Recommended Response from Target MSC to Serving MSC										
PROBLEM DEFINITION	1	2	3	4	5	6	7	8	9	Notes
RETURN ERROR Error Code										
<i>UnrecognizedMIN</i>								X		
<i>UnrecognizedESN</i>										a
<i>MIN/HLRMismatch</i>										a
<i>OperationSequenceProblem</i>									X	
<i>ResourceShortage</i>		X								
<i>OperationNotSupported</i>	X									b
<i>TrunkUnavailable</i>							X			
<i>ParameterError</i>					X					
<i>SystemFailure</i>			X							
<i>UnrecognizedParameterValue</i>				X						
<i>FeatureInactive</i>										a
<i>MissingParameter</i>						X				
RETURN RESULT										c

Problem Detections:

1. The requested MAP operation is recognized, but not supported by the receiving Target MSC or the requesting functional entity is not authorized.
2. A required Target MSC resource (e.g., voice/traffic channel, internal memory record, MSC is fully occupied) is temporarily not available (e.g., congestion).
3. A required resource (e.g., data base access, functional entity) is not presently accessible due to a failure. Human intervention may be required for resolution.
4. Supplied parameter (e.g., TDMACallMode, TargetCellID, InterMSCCircuitID, ChannelData, ServingCellID, StationClassMark, BillingID, TDMAChannelData) value is unrecognized or has nonstandard values or the Target MSC does not support the requested value (e.g., mode, target cell, inter-MSC trunk circuit, channel number).

- 1 5. A TDMAChannelData parameter was supplied, but the supplied ChannelData parameter was not
2 zero length.
- 3 6. An optional parameter (e.g., TDMACallMode, TDMAChannelData) required by the Target MSC
4 was expected, but not received.
5 The supplied ChannelData parameter was of zero length, but the Target MSC expected
6 TDMAChannelData parameter was not received.
- 7 7. The supplied InterMSCCircuitID parameter value is valid, but this trunk circuit is presently *Active*,
8 *Locally Blocked* or *Locally and Remotely Blocked*.
- 9 8. The supplied MobileIdentificationNumber parameter is not recognized as an MS authorized for
10 handoff.
- 11 9. The supplied InterSwitchCount parameter value exceeds the defined *MAXHANDOFF* threshold
12 value.

Notes:

- 13 a. This Error Code is not an appropriate Target MSC response to a FacilitiesDirective transaction.
- 14 b. It is recommended that a Target MSC supports FacilitiesDirective transactions.
- 15 c. Only the RETURN RESULT operations needing clarification have been included.

4.11.3 Target MSC Handoff Forward

Upon request, the Target MSC shall do the following:

- 1 Start the Mobile Arrival Timer (MAT).
- 2 WAIT for MS arrival on designated voice/traffic channel:
- 3 WHEN the MS is received on the designated voice/traffic channel:
 - 3-1 Stop timer (MAT).
 - 3-2 Complete the voice path between the voice/traffic channel(s) and the inter-MSC trunk.
 - 3-3 Send a MobileOnChannel INVOKE to the Serving MSC.
 - 3-4 IF the HandoffState parameter was received:
 - 3-4-1 IF its value is *Terminator is handing off*:
 - 3-4-1-1 Continue to alert the MS.
 - 3-4-1-2 Start an alerting timer.
 - 3-4-1-3 WAIT for MS to answer:
 - 3-4-1-4 WHEN the MS answers:
 - 3-4-1-4-1 Stop the alerting timer.
 - 3-4-1-4-2 GOTO the “MSC Initiating InterSystemAnswer” task (see 4.24.2).
 - 3-4-1-5 WHEN radio contact with the MS is lost:
 - 3-4-1-5-1 Stop the alerting timer.
 - 3-4-1-5-2 Include the ReleaseReason parameter indicating *clear forward*.
 - 3-4-1-5-3 Execute the “MSC Initiation of Facilities Release” task (see 4.13.1).
 - 3-4-1-5-4 Exit this task.
 - 3-4-1-6 WHEN a FacilitiesRelease INVOKE is received (see 4.13.2):
 - 3-4-1-6-1 Stop the alerting timer.
 - 3-4-1-6-2 Exit this task.
 - 3-4-1-7 WHEN the alerting timer expires:

- 3-4-1-7-1 Execute the “MSC Initiation of Facilities Release ” task (see 4.13.1). 1
- 3-4-1-7-2 Exit this task. 2
- 3-4-1-8 (Further handoffs are not supported here.) 3
- 3-4-1-9 (Handoff back is allowed here and the HandoffState parameter should be 4
included.) 5
- 3-4-1-10 ENDWAIT. 6
- 3-4-2 ELSEIF the value is *Originator is handing off* AND IF answer supervision is 7
provided for handed-off MSs: 8
- 3-4-2-1 Execute the “MSC Awaiting InterSystemAnswer” task (see 4.24.1). 9
- 3-4-2-2 (Do desired answer supervision tasks.) 10
- 3-4-3 ENDIF. 11
- 3-5 ENDIF. 12
- 4 WHEN a FacilitiesRelease INVOKE is received for the inter-MSC facilities (see 13
4.13.2): 14
- 4-1 Stop timer (MAT). 15
- 5 WHEN the (MAT) timer expires: 16
- 5-1 Execute “Local Recovery Procedures” task (see 3.5.1). 17
- 5-2 Release the reserved voice/traffic channel(s); however, do not send a 18
FacilitiesRelease INVOKE. 19
- 6 ENDWAIT. 20
- 7 Exit this task. 21

4.12 FACILITIES DIRECTIVE 2

Facilities Directive 2 uses the Section 4.11 FacilitiesDirective procedures.

4.13 FACILITIES RELEASE

In the following discussions “initiating MSC” refers to the MSC initiating a facilities release transaction and “receiving MSC” refers to the MSC at the other end of the inter-MSC trunk being released.

4.13.1 MSC Initiation of Facilities Release

When an MSC determines that an inter-MSC trunk should be released it shall:

- 1 Include the ReleaseReason parameter set to the proper value. 46
- 2 IF the MSC is the Serving MSC: 47
 - 2-1 Set bit 8 of the Segment Counter field of the BillingID parameter to 1 48
(indicating that it is the last Serving MSC). 49
 - 2-2 Include the BillingID parameter. 50
- 3 ELSEIF the MSC is a Tandem MSC: 51
 - 3-1 IF the BillingID parameter is received: 52
 - 3-1-1 Relay the BillingID parameter. 53

1 3-2 ENDIF.

2

3 4 ENDIF.

4 5 Start the Clear Trunk Timer (CTT).

5 6 Send a FacilitiesRelease INVOKE to the other MSC of an intersystem trunk.

6

7 7 WAIT for facilities release response:

8 8 WHEN a RETURN RESULT is received:

9

10 8-1 Stop timer (CTT).

11 8-2 IF the message can be processed:

12 8-2-1 Mark the inter-MSC trunk as *idle*.

13 8-3 ELSE:

14 8-3-1 Perform Local Recovery Procedures (see 3.5.1).

15 8-4 ENDIF.

16

17 8-5 IF the MSC is the Anchor MSC:

18 8-5-1 IF a BillingID parameter is received:

19 8-5-1-1 Extract the SegmentCounter field to close the *DMH* audit record (see

20 *DMH* for more information).

21 8-5-2 ELSE:

22 8-5-2-1 Close the *DMH* audit record with a unknown number of segments.

23 8-5-3 ENDIF.

24

25 8-6 ENDIF.

26

27 9 WHEN a RETURN ERROR or REJECT is received:

28 9-1 Stop timer (CTT).

29 9-2 Perform Local Recovery Procedures (see 3.5.1).

30 9-3 IF the MSC is the Anchor MSC:

31 9-3-1 Close the *DMH* audit record with a unknown number of segments.

32 9-4 ENDIF.

33

34 10 WHEN timer (CTT) expires:

35 10-1 See Chapter 4 Section 5.2.5.1.

36 10-2 IF the MSC is the Anchor MSC:

37 10-2-1 Close the *DMH* audit record with a unknown number of segments.

38 10-3 ENDIF.

39

40 11 ENDWAIT.

41

42 12 Exit this task.

43

44

45

46

47

48

49

50

51

52

53

54

55

56

57

58

59

60

4.13.2 MSC Receiving FacilitiesRelease INVOKE

Upon receipt of a FacilitiesRelease INVOKE an MSC shall:

1 IF the received message can be processed:

1-1 Mark the inter-MSC trunk as *idle*.

1-2 IF there is a task waiting for the indicated intersystem trunk.

1-2-1 Pass a FacilitiesRelease message to the waiting task (e.g.,

	“Serving MSC Initiating a Facilities Directive” task (see 4.11.1),	1
	“Target MSC Handoff Forward” task (see 4.11.3),	2
	“Serving MSC Initiating a Handoff Back” task (see 4.16.1),	3
	“Target MSC Handoff Back” task (see 4.16.3),	4
	“Serving MSC Initiating a Handoff-To-Third” task (see 4.20.1),	5
	“Tandem MSC Receiving a HandoffToThird INVOKE” task (see 4.20.2),	6
	“MSC Initiation of Facility Directive for Path Minimization” task (see	7
	4.20.4),	8
	“Anchor MSC Initiating an Authentication Directive Forward” task (see	9
	4.2.1),	10
	“MSC Awaiting InterSystemAnswer” task (see 4.24.1),	11
	“MSC Initiating InterSystemAnswer” task (see 4.24.3)).	12
1-3	ENDIF.	13
1-4	IF the receiving MSC is the Anchor MSC:	14
1-4-1	IF a BillingID parameter is received:	15
1-4-1-1	Extract the SegmentCounter field to close the audit record (see <i>DMH</i> for	16
	more information).	17
1-4-2	ELSE:	18
1-4-2-1	Close the <i>DMH</i> audit record with a unknown number of segments.	19
1-4-3	ENDIF.	20
1-4-4	Send a RETURN RESULT.	21
1-5	ELSEIF the receiving MSC is the Serving MSC:	22
1-5-1	Include the BillingID parameter containing the number of segments.	23
1-5-2	Send a RETURN RESULT.	24
1-6	ELSEIF the receiving MSC is a Tandem MSC:	25
1-6-1	IF the receiving MSC is not waiting for a FacilitiesRelease RETURN	26
	RESULT (see 4.13.1):	27
1-6-1-1	Relay the ReleaseReason parameter received in the INVOKE.	28
1-6-1-2	Execute “MSC Initiating a Facilities Release” task (see 4.13.1).	29
1-6-1-3	Relay the BillingID parameter containing the number of segments.	30
1-6-2	ENDIF.	31
1-6-3	Send a RETURN RESULT.	32
1-7	ELSE (the receiving MSC is not the Anchor, Tandem or Serving MSC):	33
1-7-1	Send a RETURN ERROR with the proper Error Code value (see the following	34
	table).	35
1-7-2	Perform Local Recovery Procedures (see 3.5.1).	36
1-8	ENDIF.	37
2	ELSE:	38
2-1	Send a RETURN ERROR with the proper Error Code value (see the following	39
	table).	40
2-2	Perform Local Recovery Procedures (see 3.5.1).	41
3	ENDIF.	42

4 Exit this task.

Table 21 Receiving MSC FacilitiesRelease Response

Problem Detection and Recommended Response from Receiving MSC to Initiating MSC								
PROBLEM DEFINITION	1	2	3	4	5	6	7	Notes
RETURN ERROR Error Code								
<i>UnrecognizedMIN</i>					X			
<i>UnrecognizedESN</i>								a
<i>MIN/HLRMismatch</i>								a
<i>OperationSequenceProblem</i>								a
<i>ResourceShortage</i>		X						
<i>OperationNotSupported</i>	X							b
<i>TrunkUnavailable</i>								a
<i>ParameterError</i>								a
<i>SystemFailure</i>			X					
<i>UnrecognizedParameterValue</i>				X				
<i>FeatureInactive</i>								a
<i>MissingParameter</i>						X		
RETURN RESULT							X	c

Problem Detections:

1. The requested MAP operation is recognized, but not supported by the receiving MSC or the requesting functional entity is not authorized.
2. A required MSC resource (e.g., internal memory record, MSC is fully occupied) is temporarily not available (e.g., congestion).
3. A required resource (e.g., data base access, functional entity) is not presently accessible due to a failure. Human intervention may be required for resolution.
4. A supplied parameter (e.g., InterMSCCircuitID) value is unrecognized or has a nonstandard value (e.g., the receiving MSC does not support the requested trunk group number or trunk member number value).
5. A call is presently active on the supplied InterMSCCircuitID parameter trunk circuit, but the supplied MobileIdentificationNumber parameter is not active (involved in the call) on the identified trunk circuit.
6. An optional parameter (e.g., MobileIdentificationNumber etc.) required by the receiving MSC was expected, but not delivered.
7. The supplied InterMSCCircuitID parameter value is valid, but this trunk circuit is presently *idle*.

Notes:

- a. This Error Code is not an appropriate MSC response to a FacilitiesRelease transaction.
- b. It is recommended that an MSC supports FacilitiesRelease transactions.
- c. Only the RETURN RESULT operations needing clarification have been included.

4.14 FEATURE REQUEST

4.14.1 MSC Detecting Feature Request

When performing digit analysis of the dialed digits received from the MS, the MSC detects that the dialed digits are a feature control access. It shall perform the following:

- 1 Include the BillingID parameter set to identify the current call for billing and redirection purposes.
- 2 Include the Digits (Dialed) parameter set to the digits received from the MS.
- 3 Include the ElectronicSerialNumber parameter set to identify the MS.
- 4 Include the MobileIdentificationNumber parameter set to identify the MS.
- 5 Include the MSCID parameter set to the identity of the MSC.
- 6 IF any indicator is set in the OneTimeFeatureIndicator parameter:
 - 6-1 Include the OneTimeFeatureIndicator parameter.
 - 7 ENDIF.
- 8 Include SenderIdentificationNumber parameter set to the identification number of the MSC.
- 9 Include TransactionCapability parameter set appropriately.
- 10 IF the subscriber is involved in a conference call:
 - 10-1 Include the ConferenceCallingIndicator parameter set to the number of conferees currently in the call.
 - 11 ENDIF.
- 12 Send a FeatureRequest INVOKE to the HLR associated with the MS.
- 13 Start the Feature Request Response Timer (FRRT).
- 14 WAIT for Feature Request response:
- 15 WHEN a RETURN RESULT is received:
 - 15-1 Stop timer (FRRT).
 - 15-2 IF the message can be processed:
 - 15-2-1 IF the MS is still connected:
 - 15-2-1-1 IF the AnnouncementList parameter is received:
 - 15-2-1-1-1 Execute the “Play All Announcements in the AnnouncementList” task (see 3.2.5).
 - 15-2-1-1-2 ELSEIF the FeatureResult parameter indicates *Successful* operation:
 - 15-2-1-1-2-1 Provide a successful indication to the MS.
 - 15-2-1-1-3 ELSE:
 - 15-2-1-1-3-1 Provide an unsuccessful indication to the MS.
 - 15-2-1-1-4 ENDIF.
 - 15-2-1-1-5 IF the OneTimeFeatureIndicator parameter is received:
 - 15-2-1-1-5-1 Store the received OneTimeFeatureIndicator parameter.
 - 15-2-1-1-6 ENDIF.
 - 15-2-1-1-7 IF the ConferenceCallingIndicator parameter is received:

1 15-2-1-7-1 Execute the “MSC CC Invocation” task (see 5.10.3).
2
3 15-2-1-8 ENDIF.
4 15-2-1-9 IF an ActionCode parameter is received:
5 15-2-1-9-1 Execute the “MSC ActionCode Processing” task (see 3.2.9)
6 15-2-1-10 ENDIF.
7
8 15-2-1-11 IF the MS is in a state capable of routing a call (e.g., after dialing a
9 feature code from an idle state or a call hold state).
10
11 15-2-1-11-1 IF the TerminationList parameter is received:
12 15-2-1-11-1-1 Execute the “MSC Routing Points Of Return” task (see 3.2.6).
13 15-2-1-11-2 ENDIF.
14
15 15-2-1-12 ENDIF.
16 15-2-1-13 IF Digits (Dialed) parameter is received:
17 15-2-1-13-1 Execute the “MSC Analyze MS Dialed Number” task (see 3.2.3)
18 (without re-querying the HLR for the same digits).
19 15-2-1-14 ENDIF.
20
21 15-2-2 ENDIF.
22
23 15-3 ELSE the message cannot be processed:
24 15-3-1 Execute “Local Recovery Procedures” task (see 3.5.1).
25 15-3-2 IF the MS is still connected:
26 15-3-2-1 Provide an unsuccessful indication to the MS.
27 15-3-3 ENDIF.
28
29 15-4 ENDIF.
30
31 16 WHEN a RemoteUserInteractionDirective INVOKE is received:
32 16-1 Stop timer (FRRT).
33 16-2 Execute the “MSC Remote User Interaction” task (see 4.39.2).
34 16-3 Start the Feature Request Response Timer (FRRT).
35 16-4 Remain in this state.
36
37 17 WHEN a RETURN ERROR or REJECT is received:
38 17-1 Stop timer (FRRT).
39 17-2 Execute “Local Recovery Procedures” task (see 3.5.1).
40 17-3 IF the MS is still connected:
41 17-3-1 Provide an unsuccessful indication to the MS.
42 17-4 ENDIF.
43
44 18 WHEN the MS disconnects:
45 18-1 Remain in this state (to handle possible call abandons).
46
47 19 WHEN timer (FRRT) expires:
48 19-1 Execute “Local Recovery Procedures” task (see 3.5.1).
49 19-2 IF the MS is still connected:
50 19-2-1 Provide an unsuccessful indication to the MS.
51 19-3 ENDIF.
52
53 20 ENDWAIT.
54
55
56
57
58
59
60

21 Exit this task.

e c e i v i e t e e e t

NOTE: The sending of a FeatureRequest to a VLR is not recommended to give the HLR more direct control over feature code operations. This operation is not supported at the VLR and may be eliminated in the future.

When a VLR receives a FeatureRequest INVOKE, it shall perform the following:

- 1 *If the received message cannot be processed:*
 - 1-1 *Send a FeatureRequest RETURN ERROR with a proper error code to the requesting MSC.*
 - 1-2 *E it this task.*
- 2 *If the received digits are a local feature control access¹:*
 - 2-1 *Update the stored information related to the requested local feature control if applicable.*
 - 2-2 *Send a FeatureRequest RETURN RESULT to the requesting MSC.*
 - 2-3 *E it this task.*
- 3 *If the received digits are a remote feature control access:*
 - 3-1 *Set the Remote Feature Control Timer (RFCT) as indicated in the VLR's internal parameters table.*
 - 3-2 *Send a FeatureRequest INVOKE to the MS's associated HLR.*
 - 3-3 *If an invalid RETURN RESULT or a RETURN ERROR is received OR IF timer (RFCT) expires:*
 - 3-3-1 *Start internal OA&M procedures (See Chapter 4, Section 5).*
 - 3-3-2 *E it this task.*
 - 3-3-3 *Begin recovery procedures according to the VLR's internal algorithm.*
 - 3-4 *If a valid RETURN RESULT is received:*
 - 3-4-1 *Stop timer (RFCT).*
 - 3-4-2 *Send a FeatureRequest RETURN RESULT to the requesting MSC.*
 - 3-4-3 *E it this task.*

4.14.3 HLR Receiving FeatureRequest INVOKE

When an HLR receives a FeatureRequest INVOKE, it shall perform the following:

- 1 IF the received message can be processed:
 - 1-1 IF the OneTimeFeatureIndicator parameter is not received:
 - 1-1-1 Set the OneTimeFeatureIndicator parameter to all zeros.
 - 1-2 ENDIF.

¹Provision of local feature control is for further study.

1 1-3 IF the received Digits (Dialed) parameter contain a feature code:
2
3 1-3-1 IF SPINA is activated:
4 1-3-1-1 IF the dialed feature code is not the SPINA De-activation feature code:
5 1-3-1-1-1 Include the FeatureResult parameter set to *Unsuccessful* to indicate
6 unsuccessful feature operation.
7
8 1-3-1-1-2 Send a RETURN RESULT.
9 1-3-1-1-3 Exit this task.
10 1-3-1-2 ENDIF.
11 1-3-2 ENDIF.
12 1-3-3 CASE feature operation based on dialed feature code (to determine the
13 PointOfReturn and relevant profile parameters) OF:
14 1-3-4 FC: Execute the “HLR CD Activation” task (see 5.1.1).
15 1-3-5 IF the PointOfReturn is indicated:
16 1-3-5-1 GOTO FeatReqPointOfReturn.
17 1-3-6 ENDIF.
18 1-3-7 FC: Execute the “HLR CD De-Activation” task (see 5.1.2).
19 1-3-8 IF the PointOfReturn is indicated:
20 1-3-8-1 GOTO FeatReqPointOfReturn.
21 1-3-9 ENDIF.
22 1-3-10 FC: Execute the “HLR CFB Registration” task (see 5.2.1).
23 1-3-11 IF the PointOfReturn is indicated:
24 1-3-11-1 GOTO FeatReqPointOfReturn.
25 1-3-12 ENDIF.
26 1-3-13 FC: Execute the “HLR CFB De-Registration” task (see 5.2.2).
27 1-3-14 IF the PointOfReturn is indicated:
28 1-3-14-1 GOTO FeatReqPointOfReturn.
29 1-3-15 ENDIF.
30 1-3-16 FC: Execute the “HLR CFB Activation” task (see 5.2.3).
31 1-3-17 IF the PointOfReturn is indicated:
32 1-3-17-1 GOTO FeatReqPointOfReturn.
33 1-3-18 ENDIF.
34 1-3-19 FC: Execute the “HLR CFB De-Activation” task (see 5.2.4).
35 1-3-20 IF the PointOfReturn is indicated:
36 1-3-20-1 GOTO FeatReqPointOfReturn.
37 1-3-21 ENDIF.
38 1-3-22 FC: Execute the “HLR CFD Registration” task (see 5.3.1).
39 1-3-23 IF the PointOfReturn is indicated:
40 1-3-23-1 GOTO FeatReqPointOfReturn.
41 1-3-24 ENDIF.
42 1-3-25 FC: Execute the “HLR CFD De-Registration” task (see 5.3.2).
43 1-3-26 IF the PointOfReturn is indicated:
44
45
46
47
48
49
50
51
52
53
54
55
56
57
58
59
60

1-3-26-1	GOTO FeatReqPointOfReturn.	1
1-3-27	ENDIF.	2
1-3-28	<i>FC</i> : Execute the “HLR CFD Activation” task (see 5.3.3).	3
1-3-29	IF the PointOfReturn is indicated:	4
1-3-29-1	GOTO FeatReqPointOfReturn.	5
1-3-30	ENDIF.	6
1-3-31	<i>FC</i> : Execute the “HLR CFD De-Activation” task (see 5.3.4).	7
1-3-32	IF the PointOfReturn is indicated:	8
1-3-32-1	GOTO FeatReqPointOfReturn.	9
1-3-33	ENDIF.	10
1-3-34	<i>FC</i> : Execute the “HLR CFNA Registration” task (see 5.4.1).	11
1-3-35	IF the PointOfReturn is indicated:	12
1-3-35-1	GOTO FeatReqPointOfReturn.	13
1-3-36	ENDIF.	14
1-3-37	<i>FC</i> : Execute the “HLR CFNA De-Registration” task (see 5.4.2).	15
1-3-38	IF the PointOfReturn is indicated:	16
1-3-38-1	GOTO FeatReqPointOfReturn.	17
1-3-39	ENDIF.	18
1-3-40	<i>FC</i> : Execute the “HLR CFNA Activation” task (see 5.4.3).	19
1-3-41	IF the PointOfReturn is indicated:	20
1-3-41-1	GOTO FeatReqPointOfReturn.	21
1-3-42	ENDIF.	22
1-3-43	<i>FC</i> : Execute the “HLR CFNA De-Activation” task (see 5.4.4).	23
1-3-44	IF the PointOfReturn is indicated:	24
1-3-44-1	GOTO FeatReqPointOfReturn.	25
1-3-45	ENDIF.	26
1-3-46	<i>FC</i> : Execute the “HLR CFU Registration” task (see 5.5.1).	27
1-3-47	IF the PointOfReturn is indicated:	28
1-3-47-1	GOTO FeatReqPointOfReturn.	29
1-3-48	ENDIF.	30
1-3-49	<i>FC</i> : Execute the “HLR CFU De-Registration” task (see 5.5.2).	31
1-3-50	IF the PointOfReturn is indicated:	32
1-3-50-1	GOTO FeatReqPointOfReturn.	33
1-3-51	ENDIF.	34
1-3-52	<i>FC</i> : Execute the “HLR CFU Activation” task (see 5.5.3).	35
1-3-53	IF the PointOfReturn is indicated:	36
1-3-53-1	GOTO FeatReqPointOfReturn.	37
1-3-54	ENDIF.	38
1-3-55	<i>FC</i> : Execute the “HLR CFU De-Activation” task (see 5.5.4).	39
1-3-56	IF the PointOfReturn is indicated:	40
1-3-56-1	GOTO FeatReqPointOfReturn.	41
		42
		43
		44
		45
		46
		47
		48
		49
		50
		51
		52
		53
		54
		55
		56
		57
		58
		59
		60

1 1-3-57 ENDIF.

2 1-3-58 *FC*: Execute the “HLR CW Activation” task (see 5.7.1).

3

4 1-3-59 IF the PointOfReturn is indicated:

5 1-3-59-1 GOTO FeatReqPointOfReturn.

6

7 1-3-60 ENDIF.

8 1-3-61 *FC*: Execute the “HLR CW De-Activation” task (see 5.7.2).

9

10 1-3-62 IF the PointOfReturn is indicated:

11 1-3-62-1 GOTO FeatReqPointOfReturn.

12

13 1-3-63 ENDIF.

14 1-3-64 *FC*: Execute the “HLR CW Temporary De-Activation” task (see 5.7.3).

15

16 1-3-65 IF the PointOfReturn is indicated:

17 1-3-65-1 GOTO FeatReqPointOfReturn.

18

19 1-3-66 ENDIF.

20 1-3-67 *FC*: Execute the “HLR CNIR Temporary Activation” task (see 5.9.1).

21

22 1-3-68 IF the PointOfReturn is indicated:

23 1-3-68-1 GOTO FeatReqPointOfReturn.

24

25 1-3-69 ENDIF.

26 1-3-70 *FC*: Execute the “HLR CNIR Temporary De-Activation” task (see 5.9.2).

27

28 1-3-71 IF the PointOfReturn is indicated:

29 1-3-71-1 GOTO FeatReqPointOfReturn.

30

31 1-3-72 ENDIF.

32 1-3-73 *FC*: Execute the “HLR CC Invocation” task (see 5.10.1).

33

34 1-3-74 IF the PointOfReturn is indicated:

35 1-3-74-1 GOTO FeatReqPointOfReturn.

36

37 1-3-75 ENDIF.

38 1-3-76 *FC*: Execute the “HLR CC Drop Last Party Invocation” task (see 5.10.2).

39

40 1-3-77 IF the PointOfReturn is indicated:

41 1-3-77-1 GOTO FeatReqPointOfReturn.

42

43 1-3-78 ENDIF.

44 1-3-79 *FC*: Execute the “HLR DND Activation” task (see 5.11.1).

45

46 1-3-80 IF the PointOfReturn is indicated:

47 1-3-80-1 GOTO FeatReqPointOfReturn.

48

49 1-3-81 ENDIF.

50 1-3-82 *FC*: Execute the “HLR DND De-Activation” task (see 5.11.2).

51

52 1-3-83 IF the PointOfReturn is indicated:

53 1-3-83-1 GOTO FeatReqPointOfReturn.

54

55 1-3-84 ENDIF.

56 1-3-85 *FC*: Execute the “HLR FA Membership Activation” task (see 5.12.1).

57

58 1-3-86 IF the PointOfReturn is indicated:

59 1-3-86-1 GOTO FeatReqPointOfReturn.

60 1-3-87 ENDIF.

1-3-88	<i>FC</i> : Execute the “HLR FA Membership De-Activation” task (see 5.12.2).	1
1-3-89	IF the PointOfReturn is indicated:	2
1-3-89-1	GOTO FeatReqPointOfReturn.	3
1-3-90	ENDIF.	4
1-3-91	<i>FC</i> : Execute the “HLR MWN Demand Pip Tone Activation” task (see 5.13.1).	5
1-3-92	IF the PointOfReturn is indicated:	6
1-3-92-1	GOTO FeatReqPointOfReturn.	7
1-3-93	ENDIF.	8
1-3-94	<i>FC</i> : Execute the “HLR MWN Demand Pip Tone De-Activation” task (see 5.13.2).	9
1-3-95	IF the PointOfReturn is indicated:	10
1-3-95-1	GOTO FeatReqPointOfReturn.	11
1-3-96	ENDIF.	12
1-3-97	<i>FC</i> : Execute the “HLR MWN Demand Pip Tone Temporary De-Activation” task (see 5.13.3).	13
1-3-98	IF the PointOfReturn is indicated:	14
1-3-98-1	GOTO FeatReqPointOfReturn.	15
1-3-99	ENDIF.	16
1-3-100	<i>FC</i> : Execute the “HLR MWN Demand Alert Pip Tone Activation” task (see 5.13.4).	17
1-3-101	IF the PointOfReturn is indicated:	18
1-3-101-1	GOTO FeatReqPointOfReturn.	19
1-3-102	ENDIF.	20
1-3-103	<i>FC</i> : Execute the “HLR MWN Demand Alert Pip Tone De-Activation” task (see 5.13.5).	21
1-3-104	IF the PointOfReturn is indicated:	22
1-3-104-1	GOTO FeatReqPointOfReturn.	23
1-3-105	ENDIF.	24
1-3-106	<i>FC</i> : Execute the “HLR MAH Demand Ordering Registration” task (see 5.14.1).	25
1-3-107	IF the PointOfReturn is indicated:	26
1-3-107-1	GOTO FeatReqPointOfReturn.	27
1-3-108	ENDIF.	28
1-3-109	<i>FC</i> : Execute the “HLR MAH Membership Activation” task (see 5.14.2).	29
1-3-110	IF the PointOfReturn is indicated:	30
1-3-110-1	GOTO FeatReqPointOfReturn.	31
1-3-111	ENDIF.	32
1-3-112	<i>FC</i> : Execute the “HLR MAH Membership De-Activation” task (see 5.14.3).	33
1-3-113	IF the PointOfReturn is indicated:	34
1-3-113-1	GOTO FeatReqPointOfReturn.	35
1-3-114	ENDIF.	36
		37
		38
		39
		40
		41
		42
		43
		44
		45
		46
		47
		48
		49
		50
		51
		52
		53
		54
		55
		56
		57
		58
		59
		60

1 1-3-115 *FC*: Execute the “HLR PCA Diversion Number Registration” task (see
2 5.15.1).
3
4 1-3-116 IF the PointOfReturn is indicated:
5 1-3-116-1 GOTO FeatReqPointOfReturn.
6
7 1-3-117 ENDIF.
8 1-3-118 *FC*: Execute the “HLR PCA Diversion Number De-Registration” task (see
9 5.15.2).
10 1-3-119 IF the PointOfReturn is indicated:
11 1-3-119-1 GOTO FeatReqPointOfReturn.
12
13 1-3-120 ENDIF.
14 1-3-121 *FC*: Execute the “HLR PCA Password Registration” task (see 5.15.3).
15
16 1-3-122 IF the PointOfReturn is indicated:
17 1-3-122-1 GOTO FeatReqPointOfReturn.
18
19 1-3-123 ENDIF.
20 1-3-124 *FC*: Execute the “HLR PCA Password De-Registration” task (see 5.15.4).
21
22 1-3-125 IF the PointOfReturn is indicated:
23 1-3-125-1 GOTO FeatReqPointOfReturn.
24
25 1-3-126 ENDIF.
26 1-3-127 *FC*: Execute the “HLR PCA Activation” task (see 5.15.5).
27
28 1-3-128 IF the PointOfReturn is indicated:
29 1-3-128-1 GOTO FeatReqPointOfReturn.
30
31 1-3-129 ENDIF.
32 1-3-130 *FC*: Execute the “HLR PCA De-Activation” task (see 5.15.6).
33
34 1-3-131 IF the PointOfReturn is indicated:
35 1-3-131-1 GOTO FeatReqPointOfReturn.
36
37 1-3-132 ENDIF.
38 1-3-133 *FC*: Execute the “HLR PL Language Registration” task (see 5.16.1).
39
40 1-3-134 IF the PointOfReturn is indicated:
41 1-3-134-1 GOTO FeatReqPointOfReturn.
42
43 1-3-135 ENDIF.
44 1-3-136 *FC*: Execute the “HLR PACA Per Call Invocation” task (see 5.17.1).
45
46 1-3-137 IF the PointOfReturn is indicated:
47 1-3-137-1 GOTO FeatReqPointOfReturn.
48
49 1-3-138 ENDIF.
50 1-3-139 *FC*: Execute the “HLR SCA Diversion Number Registration” task (see
51 5.15.1).
52 1-3-140 IF the PointOfReturn is indicated:
53 1-3-140-1 GOTO FeatReqPointOfReturn.
54
55 1-3-141 ENDIF.
56 1-3-142 *FC*: Execute the “HLR SCA Diversion Number De-Registration” task (see
57 5.19.2).
58 1-3-143 IF the PointOfReturn is indicated:
59
60

1-3-143-1	GOTO FeatReqPointOfReturn.	1
1-3-144	ENDIF.	2
1-3-145	<i>FC</i> : Execute the “HLR SCA Number Registration” task (see 5.19.3).	3
1-3-146	IF the PointOfReturn is indicated:	4
1-3-146-1	GOTO FeatReqPointOfReturn.	5
1-3-147	ENDIF.	6
1-3-148	<i>FC</i> : Execute the “HLR SCA Number De-Registration” task (see 5.19.4).	7
1-3-149	IF the PointOfReturn is indicated:	8
1-3-149-1	GOTO FeatReqPointOfReturn.	9
1-3-150	ENDIF.	10
1-3-151	<i>FC</i> : Execute the “HLR SCA Activation” task (see 5.19.5).	11
1-3-152	IF the PointOfReturn is indicated:	12
1-3-152-1	GOTO FeatReqPointOfReturn.	13
1-3-153	ENDIF.	14
1-3-154	<i>FC</i> : Execute the “HLR SCA De-Activation” task (see 5.19.6).	15
1-3-155	IF the PointOfReturn is indicated:	16
1-3-155-1	GOTO FeatReqPointOfReturn.	17
1-3-156	ENDIF.	18
1-3-157	<i>FC</i> : Execute the “HLR SPINA Registration” task (see 5.20.1).	19
1-3-158	IF the PointOfReturn is indicated:	20
1-3-158-1	GOTO FeatReqPointOfReturn.	21
1-3-159	ENDIF.	22
1-3-160	<i>FC</i> : Execute the “HLR SPINA Activation” task (see 5.20.2).	23
1-3-161	IF the PointOfReturn is indicated:	24
1-3-161-1	GOTO FeatReqPointOfReturn.	25
1-3-162	ENDIF.	26
1-3-163	<i>FC</i> : Execute the “HLR SPINA De-Activation” task (see 5.20.3).	27
1-3-164	IF the PointOfReturn is indicated:	28
1-3-164-1	GOTO FeatReqPointOfReturn.	29
1-3-165	ENDIF.	30
1-3-166	<i>FC</i> : Execute the “HLR SPINI Registration” task (see 5.21.1).	31
1-3-167	IF the PointOfReturn is indicated:	32
1-3-167-1	GOTO FeatReqPointOfReturn.	33
1-3-168	ENDIF.	34
1-3-169	<i>FC</i> : Execute the “HLR VMR Voice Mailbox PIN Registration” task (see 5.23.1).	35
1-3-170	IF the PointOfReturn is indicated:	36
1-3-170-1	GOTO FeatReqPointOfReturn.	37
1-3-171	ENDIF.	38
1-3-172	<i>FC</i> : Execute the “HLR VMR Invocation” task (see 5.23.2).	39
1-3-173	IF the PointOfReturn is indicated:	40
		41
		42
		43
		44
		45
		46
		47
		48
		49
		50
		51
		52
		53
		54
		55
		56
		57
		58
		59
		60

1 1-3-173-1 GOTO FeatReqPointOfReturn.
2
3 1-3-174 ENDIF.
4 1-3-175 *DEFAULT* (the Digits (Dialed) parameter do not contain a recognized feature
5 code):
6 1-3-175-1 Include the FeatureResult parameter set to *Unsuccessful* to indicate
7 unsuccessful feature operation.
8 1-3-175-2 IF the serving system is capable of re-translating the feature code digits:
9 1-3-175-2-1 Include the Digits (Dialed) parameter set to the digits that remain to
10 be translated.
11 1-3-175-3 ENDIF.
12 1-3-175-4 Send a RETURN RESULT.
13 1-3-175-5 Exit this task.
14 1-3-176 ENDCASE.
15
16 **O**
17 1-3-176 Send a RETURN RESULT.
18 1-3-177 IF the service profile information has changed:
19 1-3-177-1 Execute the “HLR Initiating a Qualification Directive” task (see 4.32.1).
20 1-3-178 ENDIF.
21 1-4 ELSE (the received digits are not a feature code):
22 1-4-1 Include the FeatureResult parameter set to *Unsuccessful* to indicate
23 unsuccessful feature operation.
24 1-4-2 Send a RETURN RESULT.
25 1-5 ENDIF.
26 2 ELSE (the received message cannot be processed):
27 2-1 Send a RETURN ERROR with a proper Error Code value (see the following
28 table).
29 3 ENDIF.
30 4 Exit this task.
31
32
33
34
35
36
37
38
39
40
41
42
43
44
45
46
47
48
49
50
51
52
53
54
55
56
57
58
59
60

Table 22 HLR FeatureRequest Response

Problem Detection and Recommended Response from HLR to MSC														
PROBLEM DEFINITION	1	2	3	4	5	6	7	8	9	10	11	12	13	Notes
RETURN ERROR Error Code														
<i>UnrecognizedMIN</i>							X							
<i>UnrecognizedESN</i>								X						
<i>MIN/HLRMismatch</i>						X								
<i>OperationSequenceProblem</i>									X					
<i>ResourceShortage</i>		X												
<i>OperationNotSupported</i>	X													b
<i>TrunkUnavailable</i>														a
<i>ParameterError</i>				X										d
<i>SystemFailure</i>			X											
<i>UnrecognizedParameterValue</i>					X									d
<i>FeatureInactive</i>														a
<i>MissingParameter</i>														a
RETURN RESULT FeatureResult										X				c
RETURN RESULT AccessDeniedReason														c
<i>Unassigned directory number</i>											X			
<i>Inactive</i>												X		
<i>Busy</i>												X		
<i>Termination Denied</i>													X	
<i>No Page Response</i>												X		
<i>Unavailable</i>												X		

Problem Detections:

1. The requested MAP operation is recognized, but not supported, by the receiving HLR, or the requesting functional entity is not authorized.
2. A required HLR resource (e.g., internal memory record, HLR is fully occupied) is temporarily not available (e.g., congestion).
3. A required resource (e.g., data base access, functional entity) is not presently accessible due to a failure. Human intervention may be required for resolution.
4. A supplied parameter has an encoding problem (e.g., the supplied MobileIdentificationNumber parameter digit values do not meet the BCD specification, the Digits (Dialed) parameter has an inconsistent length, digits in the Digits (Dialed) parameter do not meet the BCD specification).
5. A supplied parameter value is unrecognized or has nonstandard values (e.g., *Not used*, the supplied Digits (Dialed) parameter contain an unexpected Code 11, Code 12, or ST digit, the supplied Digits (Dialed) parameter is an unexpected length, or a Digits (Dialed) parameter is using an unrecognized value for numbering plan, encoding, or type of digit).
6. The supplied MobileIdentificationNumber parameter is not in the HLR's range of MINs or directory numbers (suspect routing error).
7. The supplied MobileIdentificationNumber parameter is within the range of the HLR, but the MIN is not presently assigned to a subscriber or the MIN is either a *Delinquent Account*, *Stolen Unit*, *Duplicate Unit*, or *Unspecified*.
8. The supplied MobileIdentificationNumber parameter is within the range of the HLR, but the supplied ElectronicSerialNumber parameter is not valid for the MIN's record.
9. The supplied MobileIdentificationNumber parameter is within the range of the HLR, but the MIN is presently registered in another system.

- 1 10. The supplied Digits (Dialed) parameter did not contain a recognized feature code, termination
 2 address, or the subscriber is not authorized for the recognized feature code. Respond with a
 3 FeatureResult set to *Unsuccessful* in the FeatureRequest RETURN RESULT.
 4
 5 11. The supplied Digits (Dialed) parameter corresponds to a Mobile Directory Number that is within the
 6 range of the HLR, but the Mobile Directory Number is not presently assigned to an MS.
 7
 8 12. The supplied Digits (Dialed) parameter corresponds to an MS within the HLR, but the MS is either
 9 Inactive (powered down, failed to autonomously register, has call delivery deactivated), Busy, No
 10 Page Response or Unavailable and redirection (as Call Forwarding) does not apply.
 11
 12 13. The supplied Digits (Dialed) parameter corresponds to an MS within the HLR, but the MS has a
 13 restriction of Termination denied or is AuthorizationDenied (e.g., *Delinquent Account*, *Stolen Unit*,
 14 *Duplicate Unit*, or *Unspecified*).

14 Notes:

- 15 a. This Error Code is not an appropriate HLR response to a FeatureRequest transaction.
 16 b. It is recommended that an HLR support FeatureRequest transactions.
 17 c. Only RETURN RESULT operations needing clarification have been included.
 18 d. Include the *Parameter Identifier* in question as the FaultyParameter parameter.
 19
 20
 21

22 4.15 FLASH REQUEST

24 The Flash Request operation is used to convey user initiated depressions of the (SEND) key
 25 from the Serving MSC to the Anchor MSC to effect call features. Any digits entered by the
 26 MS user that are associated with the (SEND) key depression, will be included in the message
 27 to the Anchor MSC.
 28
 29

30 4.15.1 Serving MSC Initiating a Flash Request

32 When the Serving MSC receives a flash from an MS engaged in a voice call, it shall
 33 perform the following:
 34

- 35 1 Include the InterMSCCircuitID parameter set to the trunk for this call.
 36 2 Include the MobileIdentificationNumber parameter set to the requesting MS's MIN.
 37 3 Include the ElectronicSerialNumber parameter set to the requesting MS's ESN.
 38 4 Include the Digits (Dialed) parameter set to the digits (non-encrypted) received from
 39 the MS.
 40 5 IF the SignalingMessageEncryptionKey (SMEKEY) parameter was provided for the
 41 MS:
 42 5-1 Include the ConfidentialityModes (CMODES-actual) parameter set to the current
 43 Signaling Message Encryption mode and Voice Privacy mode of the requesting
 44 MS.
 45 6 ENDIF.
 46 7 Send a FlashRequest INVOKE toward the Anchor MSC for this call.
 47 8 Start the Flash Request Timer (FRT).
 48 9 WAIT for a Flash Request response.
 49 10 WHEN a RETURN RESULT is received:
 50 10-1 Stop timer (FRT).
 51 10-2 Exit this task.
 52 11 WHEN a RETURN ERROR or REJECT is received:
 53
 54
 55
 56
 57
 58
 59
 60

- 11-1 Stop timer (FRT).
- 11-2 Execute the “Local Recovery Procedures” task (see 3.5.1).
- 11-3 Exit this task.
- 12 WHEN the timer (FRT) expires:
 - 12-1 Execute the “Local Recovery Procedures ” task (see 3.5.1).
- 13 ENDWAIT.
- 14 Exit this task.

4.15.2 Anchor MSC Receiving a FlashRequest INVOKE

When the Anchor MSC receives a FlashRequest INVOKE, it may perform the following:

- 1 IF the received message can be processed:
 - 1-1 Send a RETURN RESULT toward the Serving MSC.
 - 1-2 IF the requesting MS’s AuthenticationCapability status information indicates that authentication is required:
 - 1-2-1 Include the SystemAccessType parameter set to indicate *Flash request*.
 - 1-2-2 Include the Digits (Dialed) parameter set equal to the Digits in the received FlashRequest INVOKE message.
 - 1-2-3 Include the ConfidentialityModes (CMODES-actual) parameter (if it was received in the FlashRequest INVOKE message).
 - 1-2-4 Execute the “MSC Initiating an AuthenticationRequest” task (see 4.4.1).
 - 1-2-5 IF authentication is successful:
 - 1-2-5-1 Effect the feature control requested by the MS flash (if applicable).
 - 1-2-6 ELSE (authentication fails):
 - 1-2-6-1 Execute recovery procedures according to the MSC’s internal algorithm.
 - 1-2-7 ENDIF.
 - 1-3 ELSE (the requesting MS is not capable of being authenticated):
 - 1-3-1 Effect the feature control requested by the MS flash (if applicable).
 - 1-4 ENDIF.
- 2 ELSE (the message cannot be processed):
 - 2-1 Send a RETURN ERROR with the proper Error Code value (see the following table) toward the Serving MSC.
- 3 ENDIF.
- 4 Exit this task.

Table 23 Anchor MSC FlashRequest Response

Problem Detection and Recommended Response from Anchor MSC to Serving MSC										
PROBLEM DEFINITION	1	2	3	4	5	6	7	8	9	Notes
RETURN ERROR Error Code										
<i>UnrecognizedMIN</i>						X				
<i>UnrecognizedESN</i>							X			
<i>MIN/HLRMismatch</i>										a
<i>OperationSequenceProblem</i>								X		
<i>ResourceShortage</i>		X								
<i>OperationNotSupported</i>	X									b
<i>TrunkUnavailable</i>										a
<i>ParameterError</i>				X						d
<i>SystemFailure</i>			X							e
<i>UnrecognizedParameterValue</i>					X					d
<i>FeatureInactive</i>									X	
<i>MissingParameter</i>										a
RETURN RESULT										c

Problem Detections:

1. The requested MAP operation is recognized, but not supported, by the receiving Anchor MSC, or the requesting functional entity is not authorized.
2. A required Anchor MSC resource (e.g., internal memory record, MSC is fully occupied) is temporarily not available (e.g., congestion).
3. A required resource (e.g., data base access, functional entity) is not presently accessible due to a failure. Human intervention may be required for resolution.
4. A supplied parameter has an encoding problem (e.g., the supplied MobileIdentificationNumber parameter digit values do not meet the BCD specification, the Digits (Dialed) parameter has an inconsistent length, digits in the Digits (Dialed) parameter do not meet the BCD specification).
5. A supplied parameter value is unrecognized or has nonstandard values (e.g., the InterMSCCircuitID does not match any circuit on the receiving MSC, a Digits (Dialed) parameter contain a Code 11, a Code 12, or an ST digit, a Digits (Dialed) parameter is using an unrecognized value for numbering plan, encoding, or type of digit).
6. The Anchor MSC does not presently have a circuit active for the supplied MobileIdentificationNumber parameter.
7. The Anchor MSC has a circuit active for the supplied MobileIdentificationNumber parameter and on the supplied InterMSCCircuitID trunk circuit, but the supplied ElectronicSerialNumber parameter is not valid for the MIN.
8. The Anchor MSC has a circuit active for the supplied MobileIdentificationNumber parameter, but the call state is not appropriate (e.g., in the Await Answer state) for the flash request.
9. The Anchor MSC has a circuit active for the supplied MobileIdentificationNumber parameter, but the attempt to act upon the flash request resulted in failure because the feature was not active.

Notes:

- a. This Error Code is not an appropriate MSC response to a FlashRequest transaction.
- b. It is recommended that an Anchor MSC supports FlashRequest transactions.
- c. Only RETURN RESULT operations needing clarification have been included.
- d. Include the *Parameter Identifier* in question as the FaultyParameter parameter.
- e. The Anchor MSC did not respond, possibly indicating that it, or a Tandem MSC does not support a FlashRequest response message.

4.15.3 Tandem MSC Receiving of a Flash Request

When a Tandem MSC receives a FlashRequest INVOKE, it shall perform the following:

- 1 IF the received message can be processed:
 - 1-1 Replace the received InterMSCCircuitID parameter value with the ID of the trunk used in the direction toward the Anchor MSC for the call.
 - 1-2 Relay the other received parameters.
 - 1-3 Send a FlashRequest INVOKE toward the Anchor MSC.
 - 1-4 Start the Flash Request Timer (FRT).
 - 1-5 WAIT for a Flash Request response.
 - 1-6 WHEN a RETURN RESULT is received:
 - 1-6-1 Stop the timer (FRT).
 - 1-6-2 IF the message can be processed:
 - 1-6-2-1 Relay the received parameters.
 - 1-6-2-2 Send a RETURN RESULT toward the Serving MSC.
 - 1-6-3 ELSE:
 - 1-6-3-1 Send a RETURN ERROR toward the Serving MSC with the Error Code indicating *SystemFailure*.
 - 1-6-4 ENDIF.
 - 1-7 WHEN a RETURN ERROR is received:
 - 1-7-1 Stop the timer (FRT).
 - 1-7-2 Relay any received parameters.
 - 1-7-3 Relay the Error Code parameter.
 - 1-7-4 Send a RETURN ERROR toward the Serving MSC.
 - 1-7-5 Perform Local Recovery Procedures (see 3.5.1).
 - 1-8 WHEN a REJECT is received:
 - 1-8-1 Stop the timer (FRT).
 - 1-8-2 Send a RETURN ERROR toward the Serving MSC with the Error Code indicating *SystemFailure*.
 - 1-8-3 Perform Local Recovery Procedures (see 3.5.1).
 - 1-9 WHEN the timer (FRT) expires:
 - 1-9-1 (Ignore it, as the Serving MSC timer should have already expired.)
 - 1-9-2 Perform Local Recovery Procedures (see 3.5.1).
 - 1-10 ENDWAIT.
- 2 ELSE (the received message cannot be processed):
 - 2-1 Send a RETURN ERROR with the proper Error Code value (see the following table) towards the Serving MSC.
- 3 ENDIF.
- 4 Exit this task.

Table 24 Tandem MSC FlashRequest Response

Problem Detection and Recommended Response from Tandem MSC to Serving (Tandem) MSC										
PROBLEM DEFINITION	1	2	3	4	5	6	7	8	9	Notes
RETURN ERROR Error Code										
<i>UnrecognizedMIN</i>						X				
<i>UnrecognizedESN</i>									X	
<i>MIN/HLRMismatch</i>										a
<i>OperationSequenceProblem</i>							X			
<i>ResourceShortage</i>		X								
<i>OperationNotSupported</i>	X									b
<i>TrunkUnavailable</i>										a
<i>ParameterError</i>				X						d
<i>SystemFailure</i>			X							e
<i>UnrecognizedParameterValue</i>					X					d
<i>FeatureInactive</i>								X		
<i>MissingParameter</i>										a
RETURN RESULT										c

Problem Detections:

1. The requested MAP operation is recognized, but not supported, by the receiving Tandem MSC, or the requesting functional entity is not authorized.
2. A required Tandem MSC resource (e.g., internal memory record, Tandem MSC is fully occupied) is temporarily not available (e.g., congestion).
3. A required resource (e.g., data base access, functional entity) is not presently accessible due to a failure. Human intervention may be required for resolution.
4. A supplied parameter has an encoding problem (e.g., the supplied MobileIdentificationNumber parameter digit values do not meet the BCD specification, the Digits (Dialed) parameter has an inconsistent length, digits in the Digits (Dialed) parameter do not meet the BCD specification).
5. A supplied parameter value is unrecognized or has nonstandard values (e.g., the InterMSCCircuitID does not match any circuit on the receiving MSC, a Digits (Dialed) parameter contain a Code 11, a Code 12, or an ST digit, a Digits (Dialed) parameter is using an unrecognized value for numbering plan, encoding, or type of digit).
6. The Tandem MSC does not presently have a circuit active for the supplied MobileIdentificationNumber parameter.
7. The Tandem MSC has a circuit active for the supplied MobileIdentificationNumber parameter, but the call state is not appropriate (e.g., in the Await Answer state) for the flash request.
8. The Tandem MSC has a circuit active for the supplied MobileIdentificationNumber parameter, but the attempt to act upon the flash request resulted in failure because the feature was not active.
9. The supplied MobileIdentificationNumber is presently active with a Tandem MSC call on the supplied InterMSCCircuitID trunk circuit, but the supplied ElectronicSerialNumber parameter is not valid for the MIN.

Notes:

- a. This Error Code is not an appropriate Tandem MSC response to a FlashRequest transaction.
- b. It is recommended that an Tandem MSC supports FlashRequest transactions.
- c. Only RETURN RESULT operations needing clarification have been included.
- d. Include the *Parameter Identifier* in question as the FaultyParameter parameter.
- e. The Anchor (Tandem) MSC did not respond, possibly indicating that it, or another Tandem MSC does not support a FlashRequest response message.

4.16 HANDOFF BACK (SHOE LACE PREVENTION)

TheHandoffBack operation is used to prevent *shoe lacing* when an MS moves from one system to another and back again.

4.16.1 Serving MSC Initiating a Handoff Back

- 1 IF the SignalingMessageEncryptionKey (SMEKEY) is available:
 - 1-1 Include the SignalingMessageEncryptionKey (SMEKEY) parameter.
 - 1-2 Include the ConfidentialityModes (CMODES-desired) parameter set according to the MS's Signaling Message Encryption mode.
- 2 ENDIF.
- 3 IF the MS supports TDMA:
 - 3-1 IF the MS is authorized to have Voice Privacy:
 - 3-1-1 IF the VoicePrivacyMask (VPMASK) is available for the MS:
 - 3-1-1-1 Include the VoicePrivacyMask (VPMASK) parameter.
 - 3-1-1-2 IF ConfidentialityModes (CMODES-desired) parameter is not received:
 - 3-1-1-2-1 Include the ConfidentialityModes (CMODES-desired) parameter.
 - 3-1-1-3 ENDIF.
 - 3-1-1-4 Set the Voice Privacy field of the ConfidentialityModes (CMODES-desired) parameter according to the MS's preferred Voice Privacy mode.
 - 3-1-2 ENDIF.
 - 3-2 ENDIF.
- 4 ENDIF.
- 5 IF the MS supports CDMA (HandoffBack2 only):
 - 5-1 IF the subscriber is authorized to have Voice Privacy:
 - 5-1-1 IF the CDMAPrivateLongCodeMask (CDMAPLCM) is available:
 - 5-1-1-1 Include the CDMAPrivateLongCodeMask (CDMAPLCM) parameter.
 - 5-1-1-2 IF ConfidentialityModes (CMODES-desired) parameter has not been received:
 - 5-1-1-2-1 Include the ConfidentialityModes (CMODES-desired) parameter.
 - 5-1-1-3 ENDIF.
 - 5-1-1-4 Set the Voice Privacy field of the ConfidentialityModes (CMODES-desired) parameter according to the MS's preferred Voice Privacy mode.
 - 5-1-1-5 Include the CDMAChannelData parameter with the Long Code Mask field set to the long code mask in use at the Serving MSC.
 - 5-1-2 ENDIF.
 - 5-2 ENDIF.
- 6 ENDIF.
- 7 CASE (currently assigned voice or traffic channel mode) OF:
 - 8 AMPS:
 - 8-1 Include the ChannelData parameter.

- 1 8-2 Include the TargetCellID parameter.
2
3 9 NAMPS (HandoffBack2 only):
4 9-1 Include the NAMPSCallMode parameter.
5 9-2 Include the ChannelData parameter.
6 9-3 Include the NAMPSChannelData parameter.
7 9-4 Include the TargetCellID parameter.
8
9 10 CDMA (HandoffBack2 only):
10
11 10-1 Include the CDMACallMode parameter.
12 10-2 Include the CDMAChannelData parameter.
13 10-3 Include the CDMA MobileProtocolRevision parameter.
14 10-4 Include the CDMA ServingOneWayDelay parameter.
15 10-5 Include the CDMA StationClassMark parameter.
16 10-6 Include the MSLocation parameter.
17 10-7 IF the handoff was mobile assisted:
18 10-7-1 Include the CDMA TargetMAHOList parameter including one or more
19 CDMA TargetMAHOInformation parameters.
20
21 10-8 ELSE (handoff was not mobile assisted):
22 10-8-1 Include the CDMA TargetMeasurementList parameter including one or more
23 CDMA TargetMeasurementInformation parameters.
24
25 10-9 ENDIF.
26
27 11 TDMA:
28
29 11-1 Include the TargetCellID parameter.
30 11-2 IF applicable:
31 11-2-1 Include the TDMABurstIndicator parameter.
32
33 11-3 ENDIF.
34 11-4 Include the TDMA CallMode parameter.
35 11-5 Include the TDMA ChannelData parameter.
36
37 12 ENDCASE.
38
39 13 Include the BillingID parameter.
40 14 Include the InterMSCCircuitID parameter.
41 15 Include the MobileIdentificationNumber parameter.
42 16 Include the ServingCellID parameter.
43 17 Start the Handoff Order Timer (HOT).
44 18 Send a HANDBACK HandoffBack or HandoffBack2) INVOKE to the Target MSC.
45 19 WAIT for a handback response:
46
47 20 WHEN a RETURN RESULT is received:
48 20-1 Stop timer (HOT).
49 20-2 IF the message can be processed:
50 20-2-1 IF required:
51 20-2-1-1 Order the MS to conform to the Target MSC's selected voice or traffic
52 channel and associated transmission modes (e.g., as indicated by the
53
54
55
56
57
58
59
60

	parameters ChannelData, NAMPSChannelData, TDMACHannelData, CDMACHannelData).	1
		2
20-2-2	ENDIF.	3
		4
20-2-3	IF the ConfidentialityModes (CMODES-Actual) parameter is received:	5
20-2-3-1	Order the MS to handoff with the Voice Privacy and SignalingMessage Encryption modes as requested.	6
		7
		8
20-2-4	ELSE:	9
20-2-4-1	Order the MS to handoff with that Voice Privacy and SignalingMessage Encryption are disabled.	10
		11
		12
20-2-5	ENDIF.	13
20-2-6	Start the Mobile Handoff Timer (MHOT).	14
20-2-7	WAIT for handoff order response:	15
		16
20-2-8	WHEN a FacilitiesRelease INVOKE is received from the Target MSC (handoff complete) (see 4.13.2):	17
		18
20-2-8-1	Stop timer (MHOT).	19
		20
20-2-9	WHEN the timer (MHOT) expires:	21
20-2-9-1	Execute "Local Recovery Procedures" task (see 3.5.1).	22
		23
20-2-9-2	IF necessary:	24
20-2-9-2-1	Execute "MSC Initiation of FacilitiesRelease" task (see 4.13.1).	25
		26
20-2-9-3	ENDIF.	27
		28
20-2-10	ENDWAIT.	29
		30
20-3	ELSE (the message cannot be processed):	31
20-3-1	Execute "Local Recovery Procedures " task (see 3.5.1).	32
		33
20-4	ENDIF.	34
		35
21	WHEN a FacilitiesRelease INVOKE is received from the Target MSC (call abandonment, see 4.13.2):	36
		37
21-1	Stop timer (HOT).	38
		39
22	WHEN a RETURN ERROR or REJECT is received:	40
		41
22-1	Stop the timer (HOT).	42
		43
22-2	Execute "Local Recovery Procedures " task (see 3.5.1).	44
		45
23	WHEN the timer HOT expires:	46
		47
23-1	Execute "Local Recovery Procedures " task (see 3.5.1).	48
		49
24	ENDWAIT.	50
		51
25	Exit this task.	52
		53
		54
		55
		56
		57
		58
		59
		60

4.16.2 Target MSC Receiving a HandoffBack INVOKE

Upon receipt of a HandoffBack INVOKE, the Target MSC shall do the following:

- 1 IF the received message can be processed:
 - 1-1 IF voice/traffic channels are available on any of the designated cell(s):
 - 1-1-1 CASE (target voice or traffic channel) OF:
 - 1-1-2 AMPS:

- 1
2
3
4
5
6
7
8
9
10
11
12
13
14
15
16
17
18
19
20
21
22
23
24
25
26
27
28
29
30
31
32
33
34
35
36
37
38
39
40
41
42
43
44
45
46
47
48
49
50
51
52
53
54
55
56
57
58
59
60
- 1-1-2-1 Include the ChannelData parameter.
 - 1-1-3 NAMPS (HandoffBack2 only):
 - 1-1-3-1 Include the NAMPSCallMode parameter.
 - 1-1-3-2 Include the ChannelData parameter.
 - 1-1-3-3 Include the NAMPSChannelData parameter.
 - 1-1-4 CDMA (HandoffBack2 only):
 - 1-1-4-1 Include the CDMAChannelData parameter.
 - 1-1-4-2 Include the CDMACodeChannelList parameter including CDMACodeChannelInformation parameters including a TargetCellID parameter and a CDMACodeChannel parameter.
 - 1-1-4-3 Include the CDMASearchWindow parameter.
 - 1-1-4-4 Include the ConfidentialityModes (CMODES-Actual) parameter.
 - 1-1-4-5 Set the actual Signaling Message Encryption field of the ConfidentialityModes (CMODES-Actual) parameter based on the presence of the SignalingMessageEncryptionKey (SMEKEY) parameter and the Target MSC preferences.
 - 1-1-4-6 Set the actual Voice Privacy field of the ConfidentialityModes (CMODES-Actual) parameter based on the presence of the CDMAPrivateLongCodeMask (CDMAPLCM) parameter, the desired state (as indicated by the ConfidentialityModes (CMODES-desired) parameter), and the capabilities of the allocated channel(s).
 - 1-1-5 TDMA:
 - 1-1-5-1 IF applicable:
 - 1-1-5-1-1 Include the TDMABurstIndicator parameter.
 - 1-1-5-2 ENDIF.
 - 1-1-5-3 Include the TDMAChannelData parameter.
 - 1-1-5-4 Include the ConfidentialityModes (CMODES-Actual) parameter.
 - 1-1-5-5 Set the actual Signaling Message Encryption field of the ConfidentialityModes (CMODES-Actual) parameter based on the presence of the SignalingMessageEncryptionKey (SMEKEY) parameter and the Target MSC preferences.
 - 1-1-5-6 Set the actual Voice Privacy field of the ConfidentialityModes (CMODES-Actual) parameter based on the presence of the VoicePrivacyMask (VPMASK) parameter, the desired state (as indicated by the ConfidentialityModes (CMODES-desired) parameter), and the capabilities of the allocated channel(s).
 - 1-1-6 ENDCASE.
 - 1-1-7 Send a RETURN RESULT.
 - 1-1-8 Execute the “Target MSC Handoff Back” task (see 4.16.3).
 - 1-2 ELSE (there are no voice/traffic channels available on the designated cell(s)):
 - 1-2-1 Send a RETURN ERROR with Error Code *ResourceShortage*.
 - 1-3 ENDIF.
 - 2 ELSE (the received message cannot be processed):
 - 2-1 Send a RETURN ERROR with a proper Error Code value (see the following table) to the requesting MSC.

- 3 ENDIF.
- 4 Exit this task.

1
2
3
4
5
6
7
8
9
10
11
12
13
14
15
16
17
18
19
20
21
22
23
24
25
26
27
28
29
30
31
32
33
34
35
36
37
38
39
40
41
42
43
44
45
46
47
48
49
50
51
52
53
54
55
56
57
58
59
60

Table 25 Target MSC HandoffBack Response

Problem Detection and Recommended Response from a Target MSC to a Serving MSC									
PROBLEM DEFINITION	1	2	3	4	5	6	7	8	Notes
RETURN ERROR Error Code									
<i>UnrecognizedMIN</i>								X	
<i>UnrecognizedESN</i>									a
<i>MIN/HLRMismatch</i>									a
<i>OperationSequenceProblem</i>							X		
<i>ResourceShortage</i>		X							
<i>OperationNotSupported</i>	X								b
<i>TrunkUnavailable</i>									a
<i>ParameterError</i>				X					
<i>SystemFailure</i>			X						
<i>UnrecognizedParameterValue</i>					X				
<i>FeatureInactive</i>									a
<i>MissingParameter</i>						X			
RETURN RESULT									c

Problem Detections:

1. The requested MAP operation is recognized, but not supported by the Target MSC or the requesting functional entity is not authorized.
2. A required Target MSC resource (e.g., voice or traffic channel, internal memory record, MSC is fully occupied) is temporarily not available (e.g., congestion).
3. A required resource (e.g., data base access, functional entity) is not presently accessible due to a failure. Human intervention may be required for resolution.
4. A supplied parameter has an encoding problem (e.g., the supplied MobileIdentificationNumber parameter digit values do not meet the BCD specification).
A TDMACHannelData parameter was supplied, but the supplied ChannelData parameter was not zero length, or two or more mutually exclusive optional parameters have been supplied (e.g., both TDMACHannelData and NAMPSChannelData).
5. A supplied parameter value is unrecognized or has nonstandard values (e.g., the InterMSCCircuitID does not match any circuit on the receiving Target (Tandem) MSC; or MSCID (Target), TDMACallMode, TargetCellID, InterMSCCircuitID, ChannelData, ServingCellID, StationClassMark, BillingID, TDMACHannelData value is unrecognized) or the received NAMPSChannelData parameter value was not supported by the received ChannelData parameter value.
6. An optional parameter (e.g., TDMACallMode, TDMACHannelData, BillingID) required by the Target (Tandem) MSC was expected, but not received.
The supplied ChannelData parameter was of zero length, but the Target MSC expected TDMACHannelData parameter was not received.
Both mutually dependent parameters were expected, but only one was received (e.g., VoicePrivacyMask (VPMASK) or SignalingMessageEncryptionKey present, but the ConfidentialityModes (CMODES-desired) parameter was not).
7. The supplied InterMSCCircuitID parameter value is valid, but this trunk circuit is presently not active with a call.

- 1 8. The supplied MobileIdentificationNumber parameter is not the MIN presently active with a Target
2 MSC call on the supplied InterMSCCircuitID trunk circuit.
3

4 Notes:

- 5 a. This Error Code is not an appropriate Target MSC response to a HandoffBack transaction.
6 b. It is recommended that a Target MSC supports HandoffBack transactions.
7 c. Only the RETURN RESULT operations needing clarification have been included.
8
9

10 **4.16.3 Target MSC Handoff Back**
11

12 After returning a HandoffBack RETURN RESULT, a HandoffBack2 RETURN RESULT, a
13 HandoffToThird RETURN RESULT or a HandoffToThird2 RETURN RESULT to the
14 serving system, the Target MSC performs the following:
15

- 16 1 IF the BillingID parameter is not received:
17 1-1 Set the Segment Counter field to FF₁₆.
18 2 ELSEIF the value of the value of the Segment Counter field of the BillingID parameter
19 is FF₁₆ (indicating *Unspecified*):
20 2-1 Do not change the value.
21 3 ELSE:
22 3-1 Increment the Segment Counter field value of the BillingID parameter by 1 (to be
23 associated with the air segment being created).
24 4 ENDIF.
25 5 Include the updated BillingID parameter for the new air time segment.
26 6 Start the Mobile Arrival Timer (MAT).
27 7 WAIT for MS to arrive to the designated channel:
28 8 WHEN the MS is received on the designated voice channel:
29 8-1 Stop timer (MAT).
30 8-2 Include the ReleaseReason parameter set to *HandoffSuccessful*.
31 8-3 Execute an “MSC Initiating a FacilitiesRelease” (see 4.13.1).
32 9 WHEN the timer (MAT) expires:
33 9-1 Execute “Local Recovery Procedures” task (see 3.5.1).
34 9-2 Release the reserved voice channel; however, do not send a FacilitiesRelease
35 INVOKE to the Serving MSC.
36 10 WHEN a FacilitiesRelease INVOKE is received (call abandonment or facility
37 handback release, see 4.13.2):
38 10-1 Stop timer (MAT).
39 11 Exit this task.
40
41
42
43
44
45
46
47
48
49

50 **4.17 HANDOFF BACK 2**
51

52 Handoff Back 2 uses the Section 4.16 Handoff Back procedures.
53
54
55
56
57
58
59
60

4.18 HANDOFF MEASUREMENT REQUEST

The Handoff Measurement Request procedures defined in the following sections are used by the Serving MSC to determine if handoff to a Candidate MSC is appropriate. Alternatively, when mobile assisted handoff (MAHO) is used, the MS measures and reports the signal quality of the candidate Cell Sites, enabling the Serving MSC to identify the Target Cell for handoff.

4.18.1 Serving MSC Initiating a Handoff Measurement Request

When a Serving MSC elects, using its internal algorithm to determine that a handoff to a Candidate MSC is appropriate, the Serving MSC may initiate a handoff to the Candidate MSC (the Serving MSC may send several handoff measurement requests to different Candidate MSCs) by doing the following:

- 1 Identify the currently assigned voice channel and associated transmission modes (e.g., include parameters ChannelData, TDMChannelData).
- 2 IF the call in progress currently has the DTX (Discontinuous) mode active:
 - 2-1 IF the Candidate MSC is known to support the DTX mode:
 - 2-1-1 Include the ChannelData parameter with the *DTX* field set appropriately.
 - 2-2 ELSE (the Candidate MSC is known not to support the DTX mode):
 - 2-2-1 Remove the call from the DTX mode (if possible).
 - 2-2-2 Include the ChannelData parameter with the DTX field set to *DTX disabled*.
 - 2-3 ENDIF.
 - 3 ENDIF.
 - 4 Send a HandoffMeasurementRequest INVOKE.
 - 5 Start the Location Measurement Maximum Response Timer (LMMRT).
 - 6 WAIT for a HandoffMeasurementRequest response:
 - 7 WHEN a RETURN RESULT is received:
 - 7-1 Stop timer (LMMRT).
 - 7-2 IF the message can be processed:
 - 7-2-1 Process the measurement response in accordance with the MSC's internal algorithms. (If necessary, use the Candidate Cell's maximum power level allowed value obtained from an internal database.)
 - 7-3 ELSE (the message cannot be processed):
 - 7-3-1 Execute the "Local Recovery Procedures" task (see 3.5.1).
 - 7-4 ENDIF.
 - 8 WHEN a RETURN ERROR or REJECT is received:
 - 8-1 Stop the timer (LMMRT).
 - 8-2 Execute the "Local Recovery Procedures" task (see 3.5.1).
 - 9 WHEN the timer (LMMRT) expires:
 - 9-1 (This may be perfectly normal.)
 - 10 ENDWAIT.

11 Exit this task.

4.18.2 Target MSC Receiving a HandoffMeasurementRequest INVOKE

When a HandoffMeasurementRequest INVOKE is received, the Candidate MSC shall:

- 1 Identify the Candidate Cell Sites corresponding to the ServingCellID parameter specified in the HandoffMeasurementRequest INVOKE.
- 2 IF none of the Candidate Cell Sites support the current voice channel, traffic channel or associated transmission modes identified in the received parameters (e.g., ChannelData, TDMAChannelData) and the Candidate MSC optionally elects to end the location process:
 - 2-1 Exit this task.
- 3 ENDIF.
- 4 Perform location measurements to target cells in accordance with the MSC's internal algorithm.
- 5 WAIT for measurement responses:
- 6 WHEN all expected measurement responses are received (or measurement period expires):
 - 6-1 IF the best candidate cell site does not meet the quality criteria of the Candidate MSC and the Candidate MSC optionally elects to end the location process:
 - 6-1-1 Exit this task.
 - 6-2 ELSE (a candidate is available):
 - 6-2-1 IF the target is an AMPS, or TDMA traffic channel:
 - 6-2-1-1 Include the SignalQuality parameter set to the appropriately converted location quality values with respect to the maximum power levels allowed in the candidate cell sites, the current MS power level (VMAC/DMAC) in the serving cell site and station class mark.
 - 6-2-1-2 Include the TargetCellID parameter.
 - 6-2-2 ELSE (some unknown target modulation type):
 - 6-2-2-1 Exit this task.
 - 6-2-3 ENDIF.
 - 6-2-4 Send a RETURN RESULT.
 - 6-3 ENDIF.
 - 7 ENDWAIT.
 - 8 Exit this task.

Table 26 Target MSC HandoffMeasurementRequest Response

Problem Detection and Recommended Response from Target MSC to Serving MSC							
PROBLEM DEFINITION	1	2	3	4	5	6	Notes
RETURN ERROR Error Code							
<i>UnrecognizedMIN</i>							a
<i>UnrecognizedESN</i>							a
<i>MIN/HLRMismatch</i>							a
<i>OperationSequenceProblem</i>							a
<i>ResourceShortage</i>		X					
<i>OperationNotSupported</i>	X						b
<i>TrunkUnavailable</i>							a
<i>ParameterError</i>				X			
<i>SystemFailure</i>			X				
<i>UnrecognizedParameterValue</i>					X		
<i>FeatureInactive</i>							a
<i>MissingParameter</i>						X	
RETURN RESULT							c

Problem Detections:

1. The requested MAP operation is recognized, but not supported by the receiving Target MSC or the requesting functional entity is not authorized.
2. A required Target MSC resource (e.g., internal memory record, MSC is fully occupied) is temporarily not available (e.g., congestion).
3. A required resource (e.g., data base access, functional entity) is not presently accessible due to a failure. Human intervention may be required for resolution.
4. A supplied parameter has an encoding problem (e.g., the supplied MobileIdentificationNumber parameter digit values do not meet the BCD specification, a TDMACHannelData parameter was received, but the supplied ChannelData parameter was not zero length).
5. A supplied parameter (e.g., StationClassMark) value is unrecognized or has nonstandard values.
6. An optional parameter (e.g., TDMACallMode, TDMACHannelData) required by the Target MSC was expected, but not received.
The supplied ChannelData parameter was of zero length, but the Target MSC expected TDMACHannelData parameter was not received.

Notes:

- a. This Error Code is not an appropriate Target MSC response to a HandoffMeasurementRequest transaction.
- b. It is recommended that a Target MSC supports HandoffMeasurementRequest transactions.
- c. Only the RETURN RESULT operations needing clarification have been included.

4.19 HANDOFF MEASUREMENT REQUEST 2

The Handoff Measurement Request 2 procedures defined in the following sections are used by the Serving MSC to determine if handoff to a Candidate MSC is appropriate. Alternatively, when mobile assisted handoff (MAHO) is used, the MS measures and reports the signal quality of the candidate Cell Sites, enabling the Serving MSC to identify the Target Cell for handoff.

4.19.1 Serving MSC Initiating a Handoff Measurement Request 2

When a Serving MSC elects, using its internal algorithm to determine that a handoff to a Candidate MSC is appropriate, the Serving MSC may initiate a handoff to the Candidate MSC (the Serving MSC may send several handoff measurement requests to different Candidate MSCs) by doing the following:

- 1 Identify the currently assigned voice channel and associated transmission modes (e.g., include parameters ChannelData, TDMACHannelData or CDMACHannelData and other air interface specific parameters).
- 2 IF the call in progress currently has the DTX (Discontinuous) mode active:
 - 2-1 IF the Candidate MSC is known to support the DTX mode:
 - 2-1-1 Include the ChannelData parameter with the *DTX* field set appropriately.
 - 2-2 ELSE (the Candidate MSC is known not to support the DTX mode):
 - 2-2-1 Remove the call from the DTX mode (if possible).
 - 2-2-2 Include the ChannelData parameter with the DTX field set to *DTX disabled*.
 - 2-3 ENDIF.
 - 3 ENDIF.
- 4 IF the in progress call currently is assigned to a NAMPS voice channel:
 - 4-1 IF the Candidate MSC is known to support NAMPS voice channels:
 - 4-1-1 Include NAMPSChannelData parameter.
 - 4-2 ELSE (the Candidate MSC is known not to support NAMPS voice channels):
 - 4-2-1 Assign the MS to an AMPS voice channel (if available).
 - 4-2-2 Include the new ChannelData parameter.
 - 4-3 ENDIF.
 - 5 ENDIF.
- 6 Send a HandoffMeasurementRequest2 INVOKE.
- 7 Start the Location Measurement Maximum Response Timer (LMMRT).
- 8 WAIT for a HandoffMeasurementRequest2 response:
 - 9 WHEN a RETURN RESULT is received:
 - 9-1 Stop timer (LMMRT).
 - 9-2 IF the message can be processed:
 - 9-2-1 Process the measurement response in accordance with the MSC's internal algorithms. (If necessary, use the Candidate Cell's maximum power level allowed value obtained from an internal database.)
 - 9-3 ELSE (the message cannot be processed):
 - 9-3-1 Execute the "Local Recovery Procedures" task (see 3.5.1).
 - 9-4 ENDIF.
 - 10 WHEN a RETURN ERROR or REJECT is received:
 - 10-1 Stop the timer (LMMRT).
 - 10-2 Execute the "Local Recovery Procedures" task (see 3.5.1).
 - 11 WHEN the timer (LMMRT) expires:
 - 11-1 (This may be perfectly normal.)
 - 12 ENDWAIT.

13 Exit this task.

4.19.2 Target MSC Receiving a HandoffMeasurementRequest2 INVOKE

When a HandoffMeasurementRequest2 INVOKE is received, the Candidate MSC shall:

- 1 Identify the Candidate Cell Sites corresponding to the ServingCellID and MSLocation parameters (if present) specified in the HandoffMeasurementRequest2 INVOKE.
- 2 IF none of the Candidate Cell Sites support the current voice channel, traffic channel or associated transmission modes identified in the received parameters (e.g., ChannelData, NAMPSChannelData, TDMACHannelData, CDMACHannelData) and the Candidate MSC optionally elects to end the location process:
 - 2-1 Exit this task.
 - 3 ENDIF.
 - 4 Perform location measurements to target cells in accordance with the MSC's internal algorithm.
 - 5 WAIT for measurement responses:
 - 6 WHEN all expected measurement responses are received (or measurement period expires):
 - 6-1 IF the best candidate cell site does not meet the quality criteria of the Candidate MSC and the Candidate MSC optionally elects to end the location process:
 - 6-1-1 Exit this task.
 - 6-2 ELSE (a candidate is available):
 - 6-2-1 IF the target is an AMPS, NAMPS or TDMA traffic channel:
 - 6-2-1-1 FOR all candidates:
 - 6-2-1-1-1 Include the SignalQuality parameter within a TargetMeasurementInformation parameter set to the appropriately converted location quality values with respect to the maximum power levels allowed in the candidate cell sites, the current MS power level (VMAC/DMAC) in the serving cell site and station class mark.
 - 6-2-1-1-2 Include the TargetCellID parameter within a TargetMeasurementInformation parameter.
 - 6-2-1-1-3 Include the TargetMeasurementInformation parameter within the TargetMeasurementList parameter.
 - 6-2-1-2 ENDFOR.
 - 6-2-1-3 Include TargetMeasurementList parameter.
 - 6-2-2 ELSEIF the target is a CDMA traffic channel:
 - 6-2-2-1 FOR all candidates:
 - 6-2-2-1-1 Convert the location quality values to the CDMA SignalQuality parameter values.
 - 6-2-2-1-2 Include the TargetCellID parameter within a CDMA TargetMeasurementInformation parameter.
 - 6-2-2-1-3 Include the CDMA SignalQuality parameter within a CDMA TargetMeasurementInformation parameter.
 - 6-2-2-1-4 IF available:

1	6-2-2-1-4-1	Include the <code>CDMATargetOneWayDelay</code> parameter within a <code>CDMATargetMeasurementInformation</code> parameter.
2		
3		
4	6-2-2-1-5	ENDIF.
5	6-2-2-1-6	Include the <code>CDMATargetMeasurementInformation</code> parameter within the <code>CDMATargetMeasurementList</code> parameter.
6		
7	6-2-2-2	ENDFOR.
8		
9	6-2-2-3	Include <code>CDMATargetMeasurementList</code> parameter.
10	6-2-3	ELSE (some unknown target modulation type):
11		
12	6-2-3-1	Exit this task.
13	6-2-4	ENDIF.
14		
15	6-2-5	Send a RETURN RESULT.
16	6-3	ENDIF.
17	7	ENDWAIT.
18		
19	8	Exit this task.
20		

Table 27 Target MSC HandoffMeasurementRequest2 Response

Problem Detection and Recommended Response from Target MSC to Serving MSC							
PROBLEM DEFINITION	1	2	3	4	5	6	Notes
RETURN ERROR							
Error Code							
<i>UnrecognizedMIN</i>							a
<i>UnrecognizedESN</i>							a
<i>MIN/HLRMismatch</i>							a
<i>OperationSequenceProblem</i>							a
<i>ResourceShortage</i>		X					
<i>OperationNotSupported</i>	X						b
<i>TrunkUnavailable</i>							a
<i>ParameterError</i>				X			
<i>SystemFailure</i>			X				
<i>UnrecognizedParameterValue</i>					X		
<i>FeatureInactive</i>							a
<i>MissingParameter</i>						X	
RETURN RESULT							c

Problem Detections:

1. The requested MAP operation is recognized, but not supported by the receiving Target MSC or the requesting functional entity is not authorized.
2. A required Target MSC resource (e.g., internal memory record, MSC is fully occupied) is temporarily not available (e.g., congestion).
3. A required resource (e.g., data base access, functional entity) is not presently accessible due to a failure. Human intervention may be required for resolution.
4. A supplied parameter has an encoding problem (e.g., the supplied `MobileIdentificationNumber` parameter digit values do not meet the BCD specification).
5. A supplied parameter (e.g., `StationClassMark`, `CDMAStationClassMark`) value is unrecognized or has nonstandard values.
6. An optional parameter (e.g., `TDMACallMode`, `CDMAChannelData`) required by the Target MSC was expected, but not received.

Notes:

- a. This Error Code is not an appropriate Target MSC response to a HandoffMeasurementRequest2 transaction.
- b. It is recommended that a Target MSC supports HandoffMeasurementRequest2 transactions.
- c. Only the RETURN RESULT operations needing clarification have been included.

4.20 HANDOFF-TO-THIRD (PATH MINIMIZATION)

Path minimization is a technique to determine the optimal trunking for call handoff between the Anchor MSC and a Target MSC. Path minimization uses the HandoffToThird operation to determine if a more optimal trunking path is available between the Target MSC and any of the current Tandem MSCs or the Anchor MSC.

4.20.1 Serving MSC Initiating a Handoff-To-Third

When the Serving MSC determines that handoff with path minimization is to be performed, it shall do the following:

- 1 Include the BillingID parameter with the value of the Segment Counter field set to the value of the stored BillingID parameter.
- 2 IF the Serving MSC counts tandem segments:
 - 2-1 IF the value of the BillingID parameter Segment Counter field is not FF₁₆:
 - 2-1-1 Increment the value of the BillingID parameter Segment Counter field by 1 (the value to be associated with the tandem segment being created).
 - 2-2 ENDIF.
- 3 ENDIF.
- 4 IF the SignalingMessageEncryptionKey (SMEKEY) is available:
 - 4-1 Include the SignalingMessageEncryptionKey (SMEKEY) parameter.
 - 4-2 Include the ConfidentialityModes (CMODES-desired) parameter set according to the MS's Signaling Message Encryption mode.
- 5 ENDIF.
- 6 IF the subscriber is authorized to have Voice Privacy:
 - 6-1 IF the MS supports TDMA:
 - 6-1-1 IF the VoicePrivacyMask (VPMASK) is available:
 - 6-1-1-1 Include the VoicePrivacyMask (VPMASK) parameter.
 - 6-1-1-2 IF ConfidentialityModes (CMODES-desired) parameter is not received:
 - 6-1-1-2-1 Include the ConfidentialityModes (CMODES-desired) parameter.
 - 6-1-1-3 ENDIF.
 - 6-1-1-4 Set the Voice Privacy field of the ConfidentialityModes (CMODES-desired) parameter according to the MS's preferred Voice Privacy mode.
 - 6-1-2 ENDIF.
 - 6-2 ENDIF.
 - 6-3 IF the MS supports CDMA:
 - 6-3-1 IF the CDMAPrivateLongCodeMask (CDMAPLCM) is available:
 - 6-3-1-1 Include the CDMAPrivateLongCodeMask (CDMAPLCM) parameter.

18	Include the MSCID (Target) parameter.	1
19	Include the ServingCellID parameter.	2
20	Include the StationClassMark parameter.	3
21	Include the TargetCellID parameter.	4
22	Send a HANDTHIRD (HandoffToThird or HandoffToThird2) INVOKE toward the Anchor MSC.	5
		6
23	Start the Handoff-To-Third Timer (HTTT).	7
24	WAIT for the handthird response:	8
25	WHEN a RETURN RESULT is received:	9
		10
25-1	Stop timer (HTTT).	11
25-2	IF the message can be processed:	12
		13
25-2-1	IF required:	14
		15
25-2-1-1	Order the MS to conform to the Target MSC's selected voice or traffic channel and associated transmission modes (e.g., as indicated by the parameters ChannelData, NAMPSChannelData, TDMACHannelData, CDMAChannelData).	16
		17
		18
		19
		20
		21
25-2-2	ENDIF.	22
25-2-3	IF the ConfidentialityModes (CMODES-Actual) parameter is provided:	23
25-2-3-1	Send the MS a Handoff Order and indicate the Voice Privacy and Signaling Message Encryption modes as requested.	24
		25
		26
25-2-4	ELSE:	27
		28
25-2-4-1	Send the MS a Handoff Order and indicate that and are disabled.	29
25-2-5	ENDIF.	30
25-2-6	Start the Handoff-To-Third Result Timer (HTTRT).	31
25-2-7	WAIT for the handoff order response:	32
25-2-8	WHEN a FacilitiesRelease INVOKE is received (handoff complete, see 4.13.2):	33
		34
		35
		36
25-2-8-1	Stop timer (HTTRT).	37
25-2-8-2	Exit this task.	38
25-2-9	WHEN the (HTTRT) timer expires:	39
		40
25-2-9-1	Execute "Local Recovery Procedures" task (see 3.5.1).	41
25-2-9-2	IF necessary:	42
		43
25-2-9-2-1	Execute "MSC Initiation of FacilitiesRelease" task (see 4.13.1).	44
25-2-9-3	ENDIF.	45
25-2-10	ENDWAIT.	46
25-3	ENDIF.	47
		48
		49
26	WHEN a FacilitiesRelease INVOKE is received for the inter-MSC facilities (call abandonment, see 4.13.2):	50
		51
26-1	Stop timer (HTTT).	52
27	WHEN a RETURN ERROR or REJECT is received:	53
		54
27-1	Stop timer (HTTT).	55
27-2	Execute "Local Recovery Procedures" task (see 3.5.1).	56
		57
		58
		59
		60

- 1 27-3 Optionally, the Serving MSC may execute the “Serving MSC Initiating a Facilities
2 Directive” task (see 4.11.1).
3
4 28 WHEN the (HTTT) timer expires:
5 28-1 Execute “Local Recovery Procedures ” task (see 3.5.1).
6 28-2 Optionally, the Serving MSC may execute the “Serving MSC Initiating a Facilities
7 Directive” task (see 4.11.1).
8
9 29 ENDWAIT.
10 30 Exit this task.
11

12 13 **4.20.2 Tandem MSC Receiving a HandoffToThird INVOKE**

14 When a Tandem MSC receives a HANDTHIRD (HandoffToThird or HandoffToThird2)
15 INVOKE, the MSC shall do the following:
16

- 17 1 IF the Tandem MSC is the Target MSC:
18 1-1 IF voice/traffic channels are available on the designated cells:
19 1-1-1 CASE the target voice or traffic channel mode OF:
20 1-1-2 AMPS:
21 1-1-2-1 Include the ChannelData parameter.
22 1-1-3 NAMPS (HandoffToThird2 only):
23 1-1-3-1 Include the ChannelData parameter.
24 1-1-3-2 Include the NAMPSChannelData parameter.
25 1-1-4 CDMA (HandoffToThird2 only):
26 1-1-4-1 Include the CDMAChannelData parameter.
27 1-1-4-2 Include the CDMACodeChannelList parameter including
28 CDMACodeChannelInformation parameters including a TargetCellID
29 parameter and a CDMACodeChannel parameter.
30 1-1-4-3 Include the CDMASearchWindow parameter.
31 1-1-4-4 Include the ConfidentialityModes (CMODES-Actual) parameter.
32 1-1-4-5 Set the actual Signaling Message Encryption field of the
33 ConfidentialityModes (CMODES-Actual) parameter based on the
34 presence of the SignalingMessageEncryptionKey (SMEKEY) parameter
35 and the Target MSC preferences.
36 1-1-4-6 Set the actual Voice Privacy field of the ConfidentialityModes
37 (CMODES-Actual) parameter based on the presence of the
38 CDMAPrivateLongCodeMask (CDMAPLCM) parameter, the desired
39 state (as indicated by the ConfidentialityModes (CMODES-desired)
40 parameter), and the capabilities of the allocated channel(s).
41 1-1-5 TDMA:
42 1-1-5-1 Include the TDMAChannelData parameter.
43 1-1-5-2 Include the ConfidentialityModes (CMODES-Actual) parameter.
44 1-1-5-3 Set the actual Signaling Message Encryption field of the
45 ConfidentialityModes (CMODES-Actual) parameter based on the
46 presence of the SignalingMessageEncryptionKey (SMEKEY) parameter
47 and the Target MSC preferences.
48
49
50
51
52
53
54
55
56
57
58
59
60

1-1-5-4	Set the actual Voice Privacy field of the ConfidentialityModes (CMODES-Actual) parameter based on the presence of the VoicePrivacyMask (VPMASK), the desired state (as indicated by the ConfidentialityModes (CMODES-desired) parameter), and the capabilities of the allocated channel(s).	1 2 3 4 5 6
1-1-6	ENDCASE.	7
1-1-7	Send a RETURN RESULT toward the Serving MSC.	8
1-1-8	Execute the “Target MSC Handoff Back” task (see 4.16.3).	9 10
1-1-9	Exit this task.	11
1-2	ELSE (there are no voice/traffic channels available on the designated cell(s)):	12
1-2-1	Send a RETURN ERROR with Error Code <i>ResourceShortage</i> .	13 14
1-2-2	Exit this task.	15 16
1-3	ENDIF.	17
2	ELSE (the Tandem MSC is not the Target MSC):	18
2-1	IF the Tandem MSC is provisioned to perform path minimization:	19 20
2-1-1	Store the VoicePrivacyMask (VPMASK) or CDMAPrivateLongCodeMask (CDMAPLCM), SignalingMessageEncryptionKey (SMEKEY), and ConfidentialityModes (CMODES-desired) parameters for later Path Minimization use.	21 22 23 24
2-1-2	Include the relevant parameters, adjusted as necessary.	25 26
2-1-3	Relay the InterMSCCircuitID parameter adjusted as necessary.	27
2-1-4	Send the HANDTHIRD INVOKE toward the Anchor MSC.	28
2-1-5	Start the Tandem Handoff-To-Third Timer (THTTT).	29 30
2-1-6	WAIT for a handthird response:	31
2-1-7	WHEN a RETURN RESULT is received:	32
2-1-7-1	Stop timer (THTTT).	33 34
2-1-7-2	IF the message can be processed:	35
2-1-7-2-1	Relay all received parameters.	36 37
2-1-7-2-2	Send the HANDTHIRD RETURN RESULT message toward the Serving MSC.	38 39
2-1-7-3	ELSE (message cannot be processed):	40
2-1-7-3-1	GOTO HandoffToThird Second Chance.	41 42
2-1-7-4	ENDIF.	43
2-1-7-5	Exit this task.	44 45
2-1-8	WHEN a FacilitiesRelease INVOKE is received from the Serving MSC (see 4.13.2):	46 47
2-1-8-1	Stop timer (THTTT).	48 49
2-1-8-2	Exit this task.	50
2-1-9	WHEN a RETURN ERROR or REJECT is received:	51
2-1-9-1	Stop timer (THTTT).	52 53
2-1-9-2	GOTO HandoffToThird Second Chance.	54
2-1-10	WHEN the timer (THTTT) expires:	55 56

T T

1
2
3
4
5
6
7
8
9
10
11
12
13
14
15
16
17
18
19
20
21
22
23
24
25
26
27
28
29
30
31
32
33
34
35
36
37
38
39
40
41
42
43
44
45
46
47
48
49
50
51
52
53
54
55
56
57
58
59
60

```

2-1-10-1      IF the difference between the InterSwitchCount value received in the
                message and the value stored in the MSC is greater than
                TANDEMDEPTH (see 2.1):
2-1-10-1-1    IF the Target MSC is not known to the Tandem MSC:
2-1-10-1-1-1  Send a RETURN ERROR with Error Code
                UnrecognizedParameterValue toward the Serving MSC.
2-1-10-1-2    ELSE (Target MSC is known the current MSC):
2-1-10-1-2-1  Execute the “MSC Initiating a FacilitiesDirective for
                PathMinimization” task (see 4.20.4).
2-1-10-1-2-2  IF a path minimization is unsuccessful:
2-1-10-1-2-2-1 Send a RETURN ERROR with Error Code
                TrunkUnavailable toward the Serving MSC.
2-1-10-1-2-3  ELSE (path minimization successful):
2-1-10-1-2-3-1 Relay the relevant received parameters.
2-1-10-1-2-3-2 Send a RETURN RESULT toward the Serving MSC.
2-1-10-1-2-4  ENDIF.
2-1-10-1-3    ENDIF.
2-1-10-2      ELSE:
2-1-10-2-1    Send a RETURN ERROR with Error Code TrunkUnavailable toward
                the Serving MSC.
2-1-10-3      ENDIF.
2-1-11        ENDWAIT.
2-2          ENDIF.
3            ENDIF.
4            Exit this task.

```

Table 28 Tandem MSC HandoffToThird Response

Problem Detection and Recommended Response from a Tandem MSC toward the Serving MSC												
PROBLEM DEFINITION	1	2	3	4	5	6	7	8	9	10	11	Notes
RETURN ERROR Error Code												
<i>UnrecognizedMIN</i>									X			
<i>UnrecognizedESN</i>										X		
<i>MIN/HLRMismatch</i>												a
<i>OperationSequenceProblem</i>								X				
<i>ResourceShortage</i>		X										
<i>OperationNotSupported</i>	X											b
<i>TrunkUnavailable</i>											X	
<i>ParameterError</i>				X								
<i>SystemFailure</i>			X									
<i>UnrecognizedParameterValue</i>					X		X					
<i>FeatureInactive</i>												a
<i>MissingParameter</i>						X						
RETURN RESULT												c

Problem Detections:

- The requested MAP operation is recognized, but not supported by the Tandem MSC or the requesting functional entity is not authorized.
- A required Tandem MSC resource (e.g., voice or traffic channel, internal memory record, MSC is fully occupied) is temporarily not available (e.g., congestion).
- A required resource (e.g., data base access, functional entity) is not presently accessible due to a failure. Human intervention may be required for resolution.
- A supplied parameter has an encoding problem (e.g., the supplied MobileIdentificationNumber parameter digit values do not meet the BCD specification).
Two or more mutually exclusive optional parameters have been supplied (e.g., both TDMAChannelData and ChannelData or CDMAChannelData and NAMPSChannelData).
- A supplied parameter value is unrecognized or has nonstandard values (e.g., the InterMSCCircuitID does not match any circuit on the receiving Tandem MSC; or MSCID(Target), TDMACallMode, TargetCellID, InterMSCCircuitID, ChannelData, ServingCellID, StationClassMark, BillingID, TDMAChannelData value is unrecognized).
- An optional parameter (e.g., TDMACallMode, TDMAChannelData, BillingID) required by the Tandem MSC was expected, but not received.
At least one mutually exclusive parameter was expected, but neither were received (e.g., TDMAChannelData or ChannelData).
Both mutually dependent parameters were expected, but only one was received (e.g., NAMPSChannelData present, but not ChannelData or VoicePrivacyMask (VPMASK) or SignalingMessageEncryptionKey present, but not ConfidentialityModes (CMODES-desired)).
- The supplied parameter's value is valid, but is not supported by the Tandem MSC (e.g., TDMACallMode, InterSwitchCount).
- The supplied InterMSCCircuitID parameter value is valid, but this trunk circuit is presently not active with a call.
The supplied InterSwitchCount parameter value exceeds the defined TANDEMDEPTH threshold value.
- The supplied MobileIdentificationNumber parameter is not the MIN presently active with a Tandem MSC call on the supplied InterMSCCircuitID trunk circuit.

1
2
3
4
5
6
7
8
9
10
11
12
13
14
15
16
17
18
19
20
21
22
23
24
25
26
27
28
29
30
31
32
33
34
35
36
37
38
39
40
41
42
43
44
45
46
47
48
49
50
51
52
53
54
55
56
57
58
59
60

- 1 10. The supplied MobileIdentificationNumber parameter is presently active with a Tandem MSC call on
 2 the supplied InterMSCCircuitID trunk circuit, but the supplied ElectronicSerialNumber parameter is
 3 not valid for the MIN.
 4
 5 11. A path minimization attempt has been made, but a Tandem MSC intersystem handoff trunk does not
 6 exist to the Target MSC, or the TandemHandoffToThird Timer (THTTT) expired, or other path
 7 minimization failures.
 8

9 Notes:

- 10 a. This Error Code is not an appropriate Tandem MSC response to a HandoffToThird transaction.
 11 b. It is recommended that a Tandem MSC supports HandoffToThird transactions.
 12 c. Only the RETURN RESULT operations needing clarification have been included.
 13

14 4.20.3 Anchor MSC Receiving a HandoffToThird INVOKE

15
 16 When the Anchor MSC receives a HANDTHIRD (HandoffToThird or HandoffToThird2)
 17 INVOKE, the MSC shall do the following:
 18

19 1 IF the Anchor MSC is the Target MSC:

20 1-1 IF voice/traffic channels are available on any of the designated cell(s):

21 1-1-1 CASE the target voice or traffic channel mode OF:

22 1-1-2 AMPS:

23 1-1-2-1 Include the ChannelData parameter.
 24

25 1-1-3 NAMPS (HandoffToThird2 only):

26 1-1-3-1 Include the ChannelData parameter.
 27

28 1-1-3-2 Include the NAMPSChannelData parameter.
 29

30 1-1-4 CDMA (HandoffToThird2 only):

31 1-1-4-1 Include the CDMAChannelData parameter.
 32

33 1-1-4-2 Include the CDMACodeChannelList parameter including
 34 CDMACodeChannelInformation parameters including a TargetCellID
 35 parameter and a CDMACodeChannel parameter.
 36

37 1-1-4-3 Include the CDMASearchWindow parameter.
 38

39 1-1-4-4 Include the ConfidentialityModes (CMODES-Actual) parameter.
 40

41 1-1-4-5 Set the actual Signaling Message Encryption field of the
 42 ConfidentialityModes (CMODES-Actual) parameter based on the
 43 presence of the SignalingMessageEncryptionKey (SMEKEY) parameter
 44 and the Target MSC preferences.
 45

46 1-1-4-6 Set the actual Voice Privacy field of the
 47 ConfidentialityModes(CMODES-Actual) parameter based on the
 48 presence of the CDMAPrivateLongCodeMask (CDMAPLCM) parameter,
 49 the desired state (as indicated by the ConfidentialityModes (CMODES-
 50 desired) parameter), and the capabilities of the allocated channel(s).
 51

52 1-1-5 TDMA:

53 1-1-5-1 Include the TDMAChannelData parameter.
 54

55 1-1-5-2 Include the ConfidentialityModes (CMODES-Actual) parameter.
 56

57 1-1-5-3 Set the actual Signaling Message Encryption field of the
 58 ConfidentialityModes (CMODES-Actual) parameter based on the
 59 SignalingMessageEncryptionKey (SMEKEY) presence of the parameter
 60 and the Target MSC preferences.

1-1-5-4	Set the actual Voice Privacy field of the ConfidentialityModes(CMODES-Actual) parameter based on the presence of the VoicePrivacyMask (VPMASK), the desired state (as indicated by the ConfidentialityModes (CMODES-desired) parameter), and the capabilities of the allocated channel(s).	1 2 3 4 5 6
1-1-6	ENDCASE.	7
1-1-7	Send a RETURN RESULT toward the Serving MSC.	8
1-1-8	Exit this task and enter the “Target MSC Handoff Back” task (see 4.16.3).	9 10
1-2	ELSE (there are no voice/traffic channels available on the designated cell(s)):	11
1-2-1	Send a RETURN ERROR with Error Code <i>ResourceShortage</i> toward the Serving MSC.	12 13
1-2-2	Exit this task.	14 15
1-3	ENDIF.	16
2	ELSE (the Anchor MSC is not the Target MSC):	17 18
2-1	IF the Target MSC is known to the Anchor MSC and the Anchor MSC is provisioned to do path minimization:	19 20
2-1-1	Execute the “MSC Initiating a FacilitiesDirective for Path Minimization” task (see 4.20.4).	21 22
2-1-2	IF a path minimization is unsuccessful:	23 24
2-1-2-1	Send a RETURN ERROR with Error Code <i>TrunkUnavailable</i> toward the Serving MSC.	25 26 27
2-1-3	ELSE (path minimization successful):	28
2-1-3-1	Relay the relevant received parameters.	29
2-1-3-2	Send a RETURN RESULT toward the Serving MSC.	30 31
2-1-4	ENDIF.	32
2-2	ELSE:	33 34
2-2-1	Send a RETURN ERROR with Error Code <i>TrunkUnavailable</i> toward the Serving MSC.	35 36
2-3	ENDIF.	37
3	ENDIF.	38 39
4	Exit this task.	40 41 42 43 44 45 46 47 48 49 50 51 52 53 54 55 56 57 58 59 60

Table 29 Anchor MSC HandoffToThird Response

Problem Detection and Recommended Response from an Anchor MSC toward the Serving MSC												
PROBLEM DEFINITION	1	2	3	4	5	6	7	8	9	10	11	Notes
RETURN ERROR Error Code												
<i>UnrecognizedMIN</i>									X			
<i>UnrecognizedESN</i>										X		
<i>MIN/HLRMismatch</i>												a
<i>OperationSequenceProblem</i>								X				
<i>ResourceShortage</i>		X										
<i>OperationNotSupported</i>	X											b
<i>TrunkUnavailable</i>											X	
<i>ParameterError</i>				X								
<i>SystemFailure</i>			X									
<i>UnrecognizedParameterValue</i>					X		X					
<i>FeatureInactive</i>												a
<i>MissingParameter</i>						X						
RETURN RESULT												c

Problem Detections:

- The requested MAP operation is recognized, but not supported by the Anchor MSC or the requesting functional entity is not authorized.
- A required Anchor MSC resource (e.g., voice or traffic channel, internal memory record, Anchor MSC is fully occupied) is temporarily not available (e.g., congestion).
- A required resource (e.g., data base access, functional entity) is not presently accessible due to a failure. Human intervention may be required for resolution.
- A supplied parameter has an encoding problem (e.g., the supplied MobileIdentificationNumber parameter digit values do not meet the BCD specification).
Two or more mutually exclusive optional parameters have been supplied (e.g., both TDMAChannelData and ChannelData or CDMAChannelData and NAMPSChannelData).
- A supplied parameter value is unrecognized or has nonstandard values (e.g., the InterMSCCircuitID does not match any circuit on the receiving Anchor MSC; or MSCID (Target), TDMACallMode, TargetCellID, InterMSCCircuitID, ChannelData, ServingCellID, StationClassMark, BillingID, TDMAChannelData unrecognized.).
- An optional parameter (e.g., TDMACallMode, TDMAChannelData, BillingID) required by the Anchor MSC was expected, but not received.
At least one mutually exclusive parameter was expected, but neither were received (e.g., TDMAChannelData or ChannelData).
Both mutually dependent parameters were expected, but only one was received (e.g., NAMPSChannelData present, but not ChannelData or VoicePrivacyMask (VPMASK) or SignalingMessageEncryptionKey present, but not ConfidentialityModes (CMODES-desired).
- The supplied parameters value is valid, but is not supported by the Anchor MSC (e.g., TDMACallMode, InterSwitchCount).
- The supplied InterMSCCircuitID parameter value is valid, but this trunk circuit is presently not active with a call.
The supplied InterSwitchCount parameter value exceeds the defined *TANDEMDEPTH* threshold value.
- The supplied MobileIdentificationNumber parameter is not the MIN presently active with an Anchor MSC call on the supplied InterMSCCircuitID trunk circuit.

10. The supplied MobileIdentificationNumber parameter is presently active with an Anchor MSC call on the supplied InterMSCCircuitID trunk circuit, but the supplied ElectronicSerialNumber parameter is not valid for the MIN.
11. A path minimization attempt has been made, but an Anchor MSC intersystem handoff trunk does not exist to the Target MSC, or the Tandem Handoff-To-Third Timer (THTTT) expired, or other path minimization failures.

Notes:

- a. This Error Code is not an appropriate Anchor MSC response to a HandoffToThird transaction.
- b. It is recommended that an Anchor MSC supports HandoffToThird transactions.
- c. Only the RETURN RESULT operations needing clarification have been included.

4.20.4 MSC Initiating a FacilitiesDirective for Path Minimization

When an MSC has selected a target MSC for an MS handoff and path minimization is known to be possible, it shall do the following:

- 1 IF an inter-MSC trunk is available:
 - 1-1 Allocate an inter-MSC trunk to the Target MSC.
 - 1-2 Relay the ChannelData, NAMPSChannelData, CDMAChannelData, and TDMAChannelData parameters (as received in the HandoffToThird INVOKE).
 - 1-3 Relay the received VoicePrivacyMask (VPMASK) or C D M A P r i v a t e L o n g C o d e M a s k (C D M A P L C M), SignalingMessageEncryptionKey (SMEKEY), TerminalType (TERMTYP) and ConfidentialityModes (CMODES-desired) parameters (as received in the HandoffToThird INVOKE).
 - 1-4 Include the InterSwitchCount parameter set to the value of the InterSwitchCount stored at the MSC incremented by 1.
 - 1-5 IF the current MSC counts tandem segments:
 - 1-5-1 IF the value of the BillingID parameter Segment Counter field is not FF₁₆:
 - 1-5-1-1 Include the BillingID parameter with the value of the BillingID parameter Segment Counter field incremented by 1 (the value to be associated with the tandem segment being created).
 - 1-5-2 ELSE:
 - 1-5-2-1 Include the BillingID parameter with the value of the Segment Counter field set to the value that was received in the HANDTHIRD INVOKE.
 - 1-5-3 ENDIF.
 - 1-6 ELSE:
 - 1-6-1 Include the BillingID parameter with the value of the Segment Counter field set to the value that was received in the HANDTHIRD INVOKE.
 - 1-7 ENDIF.
 - 1-8 Include the ElectronicSerialNumber parameter.
 - 1-9 Include the InterMSCCircuitID parameter.
 - 1-10 Include the MobileIdentificationNumber parameter.
 - 1-11 Include the MSCID (Target) parameter.
 - 1-12 Include the ServingCellID parameter.
 - 1-13 Include the StationClassMark parameter.
 - 1-14 Include the TargetCellID parameter.

- 1
2
3
4
5
6
7
8
9
10
11
12
13
14
15
16
17
18
19
20
21
22
23
24
25
26
27
28
29
30
31
32
33
34
35
36
37
38
39
40
41
42
43
44
45
46
47
48
49
50
51
52
53
54
55
56
57
58
59
60
- 1-15 Send a FACDIR (FacilitiesDirective or FacilitiesDirective2) INVOKE to the Target MSC.
 - 1-16 Start the Handoff Order Timer (HOT).
 - 1-17 WAIT for facility directive response:
 - 1-18 WHEN a RETURN RESULT is received:
 - 1-18-1 Stop timer (HOT).
 - 1-18-2 IF the message can be processed:
 - 1-18-2-1 Relay the received ChannelData, NAMPSChannelData, CDMAChannelData, and TDMAChannelData parameters.
 - 1-18-2-2 Relay the ConfidentialityModes (CMODES-Actual) parameter.
 - 1-18-2-3 Send a HandoffToThird RETURN RESULT toward the Serving MSC.
 - 1-18-2-4 Start the Mobile Handoff Order Timer (MHOT).
 - 1-18-2-5 WAIT for the MS to get on channel:
 - 1-18-2-6 WHEN a FacilitiesRelease INVOKE is received for the inter-MSC facilities (call abandonment, see 4.13.2):
 - 1-18-2-6-1 Stop timer (MHOT).
 - 1-18-2-7 WHEN an MobileOnChannel INVOKE is received from the Target MSC (handoff complete):
 - 1-18-2-7-1 Stop timer (MHOT).
 - 1-18-2-7-2 Connect the call path to the inter-MSC trunk to the Target MSC.
 - 1-18-2-7-3 Execute the “MSC Initiation of Facilities Release” task (see 4.13.1) to release the associated inter-MSC facilities toward the Serving MSC.
 - 1-18-2-8 WHEN the (MHOT) timer expires:
 - 1-18-2-8-1 Execute the “MSC Initiation of Facilities Release” task (see 4.13.1) to release the associated inter-MSC facilities toward the Target MSC.
 - 1-18-2-8-2 Execute “Local Recovery Procedures” task (see 3.5.1).
 - 1-18-2-9 ENDWAIT.
 - 1-18-3 ELSE (the message cannot be processed):
 - 1-18-3-1 Send a RETURN ERROR with Error Code *TrunkUnavailable* toward the Serving MSC.
 - 1-18-3-2 Execute “Local Recovery Procedures” task (see 3.5.1).
 - 1-18-3-3 Exit this task.
 - 1-18-4 ENDIF.
 - 1-19 WHEN a RETURN ERROR or REJECT is received:
 - 1-19-1 Stop timer (HOT).
 - 1-19-2 Send a RETURN ERROR with Error Code *TrunkUnavailable* toward the Serving MSC.
 - 1-19-3 Execute “Local Recovery Procedures ” task (see 3.5.1).
 - 1-19-4 Exit this task.
 - 1-20 WHEN a FacilitiesRelease INVOKE is received from the Serving MSC (call abandonment, see 4.13.2):
 - 1-20-1 Stop timer (HOT).

- 1-20-2 Exit this task. 1
- 1-21 WHEN the timer (HOT) expires: 2
- 1-21-1 Send a RETURN ERROR with Error Code *TrunkUnavailable* toward the 3
Serving MSC. 4
- 1-21-2 Execute “Local Recovery Procedures ” task (see 3.5.1). 5
6
- 1-22 ENDWAIT. 7
- 2 ELSE (an inter-MSC trunk is not available): 8
- 2-1 Send a RETURN ERROR with Error Code *TrunkUnavailable* toward the 9
Serving MSC. 10
- 3 ENDIF. 11
- 4 Exit this task. 12

4.21 HANDOFF-TO-THIRD 2

Handoff-to-Third 2 uses the Section 4.20 Handoff-to-Third procedures.

4.22 INFORMATION DIRECTIVE

4.22.1 HLR Initiating an Information Directive

Upon request, the HLR shall do the following:

- 1 Include the *ElectronicSerialNumber* parameter set to identify the MS. 29
- 2 Include the *MobileIdentificationNumber* parameter set to identify the MS. 30
- 3 Send an InformationDirective INVOKE to the VLR serving the MS. 31
- 4 Start the Information Directive Timer (IDT). 32
- 5 WAIT for an Information Directive response: 33
- 6 WHEN a RETURN RESULT is received: 34
- 6-1 Stop the timer (IDT). 35
- 6-2 IF the message can be processed: 36
- 6-2-1 Return to the calling task with a *successful* indication. 37
- 6-3 ELSE: 38
- 6-3-1 Execute “Local Recovery Procedures ” task (see 3.5.1). 39
- 6-3-2 Return to the calling task with an *unsuccessful* indication. 40
- 6-4 ENDIF. 41
- 7 WHEN a RETURN ERROR or REJECT is received: 42
- 7-1 Stop the timer (IDT). 43
- 7-2 Execute “Local Recovery Procedures ” task (see 3.5.1). 44
- 7-3 Return to the calling task with an *unsuccessful* indication. 45
- 8 WHEN the timer (IDT) expires: 46
- 8-1 Execute “Local Recovery Procedures ” task (see 3.5.1). 47
- 8-2 Return to the calling task with an *unsuccessful* indication. 48

1
2
3
4
5
6
7
8
9
10
11
12
13
14
15
16
17
18
19
20
21
22
23
24
25
26
27
28
29
30
31
32
33
34
35
36
37
38
39
40
41
42
43
44
45
46
47
48
49
50
51
52
53
54
55
56
57
58
59
60

9 ENDWAIT.

4.22.2 VLR Receiving an InformationDirective INVOKE

Upon receipt of an InformationDirective INVOKE, a VLR shall do the following:

- 1 IF the message can be processed:
 - 1-1 Relay all received parameters.
 - 1-2 Send an InformationDirective INVOKE to the MSC serving the MS.
 - 1-3 Start the Information Directive Timer (IDT).
 - 1-4 WAIT for an Information Directive response from the Serving MSC:
 - 1-5 WHEN a RETURN RESULT is received:
 - 1-5-1 Stop the timer (IDT).
 - 1-5-2 IF the message can be processed:
 - 1-5-2-1 Relay all received parameters.
 - 1-5-2-2 Send a RETURN RESULT to the requesting HLR.
 - 1-5-3 ELSE:
 - 1-5-3-1 Execute “Local Recovery Procedures ” task (see 3.5.1).
 - 1-5-3-2 Send a RETURN ERROR with Error Code *SystemFailure* to the requesting HLR.
 - 1-5-4 ENDIF.
 - 1-6 WHEN a RETURN ERROR or REJECT is received:
 - 1-6-1 Stop the timer (IDT).
 - 1-6-2 Execute “Local Recovery Procedures ” task (see 3.5.1).
 - 1-6-3 Send a RETURN ERROR with Error Code *SystemFailure* to the requesting HLR.
 - 1-7 WHEN the timer (IDT) expires:
 - 1-7-1 Execute “Local Recovery Procedures ” task (see 3.5.1).
 - 1-7-2 Send a RETURN ERROR with Error Code *SystemFailure* to the requesting HLR.
 - 1-8 ENDIF.
- 2 ELSE (the message cannot be processed):
 - 2-1 Send a RETURN ERROR with the proper Error Code value (see the following table) to the requesting HLR.
- 3 ENDIF.
- 4 Exit this task.

Table 30 VLR InformationDirective Response

Problem Detection and Recommended Response from VLR to HLR								
PROBLEM DEFINITION	1	2	3	4	5	6	7	Notes
RETURN ERROR Error Code								
<i>UnrecognizedMIN</i>						X		
<i>UnrecognizedESN</i>							X	
<i>MIN/HLRMismatch</i>								a
<i>OperationSequenceProblem</i>								a
<i>ResourceShortage</i>		X						e
<i>OperationNotSupported</i>	X							e
<i>TrunkUnavailable</i>								a
<i>ParameterError</i>				X				d, e
<i>SystemFailure</i>			X					e
<i>UnrecognizedParameterValue</i>								a
<i>FeatureInactive</i>								a
<i>MissingParameter</i>					X			d, e
RETURN RESULT								c

Problem Detections:

1. The requested MAP operation is recognized, but not supported, by the receiving VLR, or the requesting functional entity is not authorized.
2. A required VLR resource (e.g., internal memory record, VLR is fully occupied) is temporarily not available (e.g., congestion).
3. A required resource (e.g., data base access, functional entity) is not presently accessible due to a failure. Human intervention may be required for resolution.
4. A supplied parameter has an encoding problem (e.g., the supplied MobileIdentificationNumber parameter digit values do not meet the BCD specification).
5. An expected, or required, optional parameter (e.g., AlertCode, AnnouncementList) was not received.
6. A VLR record does not presently exist for the supplied MobileIdentificationNumber parameter.
7. A VLR record exists for the supplied MobileIdentificationNumber parameter, but the supplied ElectronicSerialNumber parameter does not match the ESN in the VLR record.

Notes:

- a. This Error Code is not an appropriate VLR response to a InformationDirective transaction.
- b. It is recommended that a VLR support InformationDirective transactions.
- c. Only RETURN RESULT operations needing clarification have been included.
- d. Include the *Parameter Identifier* in question as the FaultyParameter parameter.
- e. This response may have been originated by the MSC.

4.22.3 MSC Receiving an InformationDirective INVOKE

Upon receipt of an InformationDirective INVOKE, an MSC shall do the following:

- 1 IF the message can be processed:
 - 1-1 IF the MSC is currently serving the addressed MS:
 - 1-1-1 Execute the “MSC Special MS Alerting” (see 3.3.6).
 - 1-2 ELSE (the MS has been handed off):

- 1-2-1 Include the InterMSCCircuitID parameter set to the trunk used in the direction toward the Serving MSC.
- 1-2-2 Relay all received parameters.
- 1-2-3 Execute the “MSC Initiating an Information Forward” task (see 4.23.1).
- 1-3 ENDIF.
- 1-4 (Both serving and Anchor MSC roles with come here with the results.)
- 1-5 IF the request was accepted:
- 1-5-1 Relay all received parameters.
- 1-5-2 Send a RETURN RESULT to the transaction initiator.
- 1-6 ELSE (the request was refused):
- 1-6-1 Send a RETURN ERROR with the proper Error Code value (see the following table).
- 1-7 ENDIF.
- 2 ELSE (the message cannot be processed):
- 2-1 Send a RETURN ERROR with proper Error Code value (see the following table).
- 3 ENDIF.
- 4 Exit this task.

Table 31 MSC InformationDirective Response

Problem Detection and Recommended Response from MSC to VLR								
PROBLEM DEFINITION	1	2	3	4	5	6	7	Notes
RETURN ERROR Error Code								
<i>UnrecognizedMIN</i>						X		
<i>UnrecognizedESN</i>							X	
<i>MIN/HLRMismatch</i>								a
<i>OperationSequenceProblem</i>								a
<i>ResourceShortage</i>		X						
<i>OperationNotSupported</i>	X							b
<i>TrunkUnavailable</i>								a
<i>ParameterError</i>				X				d
<i>SystemFailure</i>			X					
<i>UnrecognizedParameterValue</i>								d
<i>FeatureInactive</i>								a
<i>MissingParameter</i>					X			d
RETURN RESULT								c

Problem Detections:

1. The requested MAP operation is recognized, but not supported, by the receiving MSC, or the requesting functional entity is not authorized.
2. A required MSC resource (e.g., internal memory record, MSC is fully occupied) is temporarily not available (e.g., congestion).
3. A required resource (e.g., data base access, functional entity) is not presently accessible due to a failure. Human intervention may be required for resolution.
4. A supplied parameter has an encoding problem (e.g., the supplied MobileIdentificationNumber parameter digit values do not meet the BCD specification).

5. An expected, or required, optional parameter (e.g., AlertCode, AnnouncementList) was not received.
6. An MSC record does not presently exist for the supplied MobileIdentificationNumber parameter.
7. An MSC record exists for the supplied MobileIdentificationNumber parameter, but the supplied ElectronicSerialNumber parameter does not match the ESN in the MSC record.

Notes:

- a. This Error Code is not an appropriate MSC response to a InformationDirective transaction.
- b. It is recommended that an MSC support InformationDirective transactions.
- c. Only RETURN RESULT operations needing clarification have been included.
- d. Include the *Parameter Identifier* in question as the FaultyParameter parameter.

4.23 INFORMATION FORWARD

4.23.1 MSC Initiating an Information Forward

Upon request, the MSC shall do the following (parameters are included before this is invoked):

- 1 Include the ElectronicSerialNumber parameter.
- 2 Include the InterMSCCircuitID parameter identifying the trunk used in the direction toward the Serving MSC.
- 3 Include the MobileIdentificationNumber parameter.
- 4 Send a InformationForward INVOKE message.
- 5 Start the Information Forward Timer (IFT).
- 6 WAIT for an Information Forward response:
 - 7 WHEN a RETURN RESULT is received:
 - 7-1 Stop the timer (IFT).
 - 7-2 IF the message can be processed:
 - 7-2-1 Return to the calling task with a *successful* indication.
 - 7-3 ELSE:
 - 7-3-1 Execute “Local Recovery Procedures” task (see 3.5.1).
 - 7-3-2 Return to the calling task with an *unsuccessful* indication.
 - 7-4 ENDIF.
 - 8 WHEN a RETURN ERROR or REJECT is received:
 - 8-1 Stop the timer (IFT).
 - 8-2 Execute “Local Recovery Procedures ” task (see 3.5.1).
 - 8-3 Return to the calling task with an *unsuccessful* indication.
 - 9 WHEN the timer (IFT) expires:
 - 9-1 Execute “Local Recovery Procedures ” task (see 3.5.1).
 - 9-2 Return to the calling task with an *unsuccessful* indication.
- 10 ENDWAIT.

4.23.2 MSC Receiving a InformationForward INVOKE

Upon receipt of an InformationForward INVOKE, an MSC shall do the following:

- 1 IF the received message can be processed:
 - 1-1 IF the MSC is the Serving MSC:
 - 1-1-1 Execute the “MSC MWN Status Change Invocation” task (see 5.13.9).
 - 1-1-2 Execute the “MSC Special MS Alerting” (see 3.3.6).
 - 1-1-3 Send a RETURN RESULT to the requesting MSC.
 - 1-2 ELSE (this is a Tandem MSC):
 - 1-2-1 Replace the received InterMSCCircuitID with the identity of the trunk used in the direction toward the Serving MSC.
 - 1-2-2 Relay all other received parameters (e.g., ElectronicSerialNumber, MobileIdentificationNumber, AlertCode, AnnouncementList, CallingPartyNumberString1, CallingPartyNumberString2, CallingPartySubaddress, MessageWaitingNotificationCount, MessageWaitingNotificationType, RedirectingNumberString, RedirectingSubaddress).
 - 1-2-3 Set the destination address to the Serving MSC or the next MSC in the handoff chain.
 - 1-2-4 Send a InformationForward INVOKE toward the Serving MSC in the call.
 - 1-2-5 Start the Information Forward Timer (IFT).
 - 1-2-6 WAIT for the Information Forward response:
 - 1-2-7 WHEN a RETURN RESULT is received:
 - 1-2-7-1 Stop the timer (IFT).
 - 1-2-7-2 Relay all received parameters.
 - 1-2-7-3 Send a RETURN RESULT towards the requesting MSC.
 - 1-2-8 WHEN a RETURN ERROR or REJECT is received:
 - 1-2-8-1 Stop the timer (IFT).
 - 1-2-8-2 CASE Error Code OF:
 - 1-2-8-3 *ParameterError*:
 - 1-2-8-3-1 IF the parameter was originated from the initiating functional entity:
 - 1-2-8-3-1-1 Send a RETURN ERROR with Error Code *ParameterError*.
 - 1-2-8-3-2 ELSE:
 - 1-2-8-3-2-1 Send a RETURN ERROR with Error Code *SystemFailure* .
 - 1-2-8-3-3 ENDIF.
 - 1-2-8-4 *OperationSequenceProblem*:
 - 1-2-8-4-1 Send a RETURN ERROR with Error Code *OperationSequenceProblem*.
 - 1-2-8-5 *DEFAULT*:
 - 1-2-8-5-1 Send a RETURN ERROR with Error Code *SystemFailure*.
 - 1-2-8-6 ENDCASE.
 - 1-2-9 WHEN the timer (IFT) expires:
 - 1-2-9-1 (The initiating functional entity timer should have expired, so no notification is necessary.)

- 1-2-10 ENDWAIT.
- 1-3 ENDIF.
- 2 ELSE (the received message cannot be processed):
- 2-1 Send a RETURN ERROR with the proper Error Code value toward the requesting MSC.
- 3 ENDIF.
- 4 Exit this task.

Table 32 Serving MSC InformationForward Response

Problem Detection and Recommended Response from the Serving MSC toward the Anchor MSC								
PROBLEM DEFINITION	1	2	3	4	5	6	7	Notes
RETURN ERROR Error Code								
<i>UnrecognizedMIN</i>						X		
<i>UnrecognizedESN</i>								a
<i>MIN/HLRMismatch</i>								a
<i>OperationSequenceProblem</i>							X	
<i>ResourceShortage</i>		X						
<i>OperationNotSupported</i>	X							b
<i>TrunkUnavailable</i>								a
<i>ParameterError</i>				X				d
<i>SystemFailure</i>			X					e
<i>UnrecognizedParameterValue</i>					X			d
<i>FeatureInactive</i>								a
<i>MissingParameter</i>								a
RETURN RESULT								c

Problem Detections:

- The requested MAP operation is recognized, but not supported, by the receiving Serving MSC, or the requesting functional entity is not authorized.
- A required Serving MSC resource (e.g., internal memory record, Serving MSC is fully occupied) is temporarily not available (e.g., congestion).
- A required resource (e.g., data base access, functional entity) is not presently accessible due to a failure. Human intervention may be required for resolution.
- A supplied parameter has an encoding problem (e.g., the supplied MobileIdentificationNumber parameter digit values do not meet the BCD specification).
- A supplied parameter value is unrecognized or has nonstandard values (e.g., the InterMSCCircuitID does not match any circuit on the receiving Serving MSC).
- The Serving MSC does not presently have a circuit active for the supplied MobileIdentificationNumber parameter.
- The Serving MSC has a circuit active for the supplied MobileIdentificationNumber parameter, but the call state is not appropriate for the requested action.

Notes:

- This Error Code is not an appropriate Serving MSC response to a InformationForward transaction.
- It is recommended that an Serving MSC supports InformationForward transactions.
- Only RETURN RESULT operations needing clarification have been included.
- Include the *Parameter Identifier* in question as the FaultyParameter parameter.

- e. The Serving MSC did not respond, possibly indicating that it, or another Tandem MSC does not support a InformationForward message.

4.24 INTERSYSTEM ANSWER

4.24.1 MSC Awaiting InterSystemAnswer

When the MSC determines that it should wait for an InterSystemAnswer message, it shall do the following:

- 1 Start the InterSystemAnswer Response Timer (ISART).
- 2 WAIT for an InterSystemAnswer INVOKE:
- 3 WHEN an InterSystemAnswer INVOKE is received from the border system:
 - 3-1 Stop the timer (ISART).
 - 3-2 Send an InterSystemAnswer RETURN RESULT to the Border MSC.
 - 3-3 Connect the call path.

NOTE: After the call has been established, a subsequent handoff to the visited (Anchor) MSC should be treated as a Handoff Back.
- 4 WHEN a FacilitiesRelease INVOKE is received (see 4.13.2):
 - 4-1 Stop the timer (ISART).
- 5 WHEN the (ISART) timer expires:
 - 5-1 Include the ReleaseReason parameter indicating *clear forward*.
 - 5-2 Execute the “Initiating MSC Initiating a Facilities Release” task (see 4.13.1).
 - 5-3 Execute “Local Recovery Procedures” task (see 3.5.1).
- 6 ENDWAIT.
- 7 Exit this task.

4.24.2 MSC Initiating InterSystemAnswer

When the MSC determines that it should send an InterSystemAnswer message, it shall do the following:

- 1 Start an alerting timer.
- 2 WAIT for the MS to answer:
- 3 WHEN the MS answers:
 - 3-1 Send an InterSystemAnswer INVOKE to the Serving MSC.
 - 3-2 Start the InterSystemAnswer (ISAT) timer.
 - 3-3 WAIT for an intersystem answer response:
 - 3-4 WHEN a RETURN RESULT is received:
 - 3-4-1 Stop (ISAT) timer.
 - 3-5 WHEN a RETURN ERROR or REJECT is received:
 - 3-5-1 Stop (ISAT) timer.
 - 3-5-2 Release associated inter-MSC trunk facility (See 4.3).
 - 3-6 WHEN a FacilitiesRelease INVOKE is received (see 4.13.2):

- 3-6-1 Stop (ISAT) timer.
- 3-6-2 Release associated inter-MSC trunk facility (See 4.3).
- 3-7 WHEN timer (ISAT) expires:
 - 3-7-1 Perform Local Recovery Procedures (see 3.5.1).
 - 3-7-2 Release associated inter-MSC trunk facility (See 4.3).
- 3-8 ENDWAIT.
- 4 WHEN a FacilitiesRelease INVOKE is received (see 4.13.2):
 - 4-1 Stop the alerting timer.
 - 4-2 Release associated inter-MSC trunk facility (See 4.3).
- 5 WHEN the alerting timer expires:
 - 5-1 Include the ReleaseReason parameter indicating *clear forward*.
 - 5-2 Execute the “Initiating MSC Initiating a Facilities Release” task (see 4.13.1).
 - 5-3 Perform Local Recovery Procedures (see 3.5.1).
- 6 ENDWAIT.
- 7 Exit this task.

Table 33 Anchor MSC InterSystemAnswer Response

Problem Detection and Recommended Response from Anchor MSC to Serving MSC							
PROBLEM DEFINITION	1	2	3	4	5	6	Notes
RETURN ERROR							
Error Code							
<i>UnrecognizedMIN</i>					X		
<i>UnrecognizedESN</i>							a
<i>MIN/HLRMismatch</i>							a
<i>OperationSequenceProblem</i>						X	
<i>ResourceShortage</i>		X					
<i>OperationNotSupported</i>	X						b
<i>TrunkUnavailable</i>							a
<i>ParameterError</i>							a
<i>SystemFailure</i>			X				
<i>UnrecognizedParameterValue</i>				X			d
<i>FeatureInactive</i>							a
<i>MissingParameter</i>							a
RETURN RESULT							c

Problem Detections:

1. The requested MAP operation is recognized, but not supported by the receiving MSC or the requesting functional entity is not authorized.
2. A required MSC resource is temporarily not available.
3. A required resource (e.g., data base access, functional entity) is not presently accessible due to a failure. Human intervention may be required for resolution.
4. A supplied parameter value is unrecognized or has nonstandard values (e.g., The supplied MobileIdentificationNumber parameter digit values do not meet the expected BCD specification).
5. The supplied MobileIdentificationNumber parameter is not the MIN presently active with a call on the supplied InterMSCCircuitID parameter trunk circuit.

1
2
3
4
5
6
7
8
9
10
11
12
13
14
15
16
17
18
19
20
21
22
23
24
25
26
27
28
29
30
31
32
33
34
35
36
37
38
39
40
41
42
43
44
45
46
47
48
49
50
51
52
53
54
55
56
57
58
59
60

- 1 6. The supplied InterMSCCircuitID parameter value is valid, but this trunk circuit is presently not
2 active with a call.
3

4 Notes:

- 5 a. This Error Code is not an appropriate response to InterSystemAnswer transaction.
6 b. It is recommended that an MSC supports InterSystemAnswer transactions.
7 c. Only the RETURN RESULT operations needing clarification have been included.
8 d. Include the *Parameter Identifier* in question as the FaultyParameter parameter.
9
10

11 4.25 INTERSYSTEM PAGE

12 4.25.1 MSC Initiating an InterSystemPage

13
14
15
16
17 When an MSC determines that it needs to request its neighboring MSC(s) to find an MS
18 which has a pending call delivery, it shall perform the following (as an independent
19 asynchronous task):
20

- 21 1 For each neighboring MSC identified, according to the MSC's topographical map and
22 the location area where the MS was last registered:
23
24 1-1 Include the BillingID parameter.
25 1-2 Include the ElectronicSerialNumber parameter set to identify the MS.
26 1-3 Include the MobileIdentificationNumber parameter set to identify the MS.
27 1-4 Include the LocationAreaID parameter set to specify the paging area for the MS.
28 1-5 Include the MSCID parameter set to the identity of the Originating MSC.
29 1-6 Include the ExtendedMSCID (Serving) parameter set to the identity of the
30 Serving MSC.
31 1-7 IF the query is launched on an SS7 network:
32 1-7-1 Include the PC_SSN parameter for the Originating MSC.
33 1-8 ENDIF.
34 1-9 Include the PageIndicator parameter set to indicate whether paging should occur
35 or that the MSC should only listen for a page response.
36 1-10 IF available:
37 1-10-1 Include the CDMAStationClassMark parameter.
38 1-11 ENDIF.
39 1-12 IF available:
40 1-12-1 Include the CDMASlotCycleIndex parameter.
41 1-13 ENDIF.
42 1-14 Relay other parameters pertinent to the call (e.g., CallingPartyNumberString1,
43 CallingPartyNumberString2, CallingPartySubaddress, Redirecting- NumberString,
44 RedirectingSubaddress).
45 1-15 Send an InterSystemPage INVOKE to the neighboring MSC.
46
47 2 ENDFOR.
48
49 3 Start the Intersystem Page Request Timer (ISPRT).
50 4 WAIT for a Intersystem Page response:
51 5 WHEN a RETURN RESULT is received:
52
53
54
55
56
57
58
59
60

5-1	IF the message can be processed:	1
5-1-1	IF AccessDeniedReason parameter is received:	2
5-1-1-1	IF other responses are expected:	3
5-1-1-1-1	Store the response.	4
5-1-1-1-2	Remain in this state.	5
5-1-1-2	ELSE:	6
5-1-1-2-1	Pass a Intersystem Page Notification with the received parameters to the waiting page in the process that spawned this task (the “Pagean MS Procedure” (see 3.3.3)).	7
5-1-1-2-2	Stop timer (ISPRT).	8
5-1-1-2-3	Exit this task.	9
5-1-1-3	ENDIF.	10
5-1-2	ELSEIF Digits parameter is received:	11
5-1-2-1	Pass a Intersystem Page Notification with the received parameters to the waiting page in the process that spawned this task (the “Page an MSProcedure” (see 3.3.3)).	12
5-1-2-2	WHILE other responses are expected:	13
5-1-2-2-1	WAIT for outstanding intersystem page responses:	14
5-1-2-2-2	WHEN a RETURN RESULT is received:	15
5-1-2-2-2-1	(Ignore it.)	16
5-1-2-2-3	WHEN a RETURN ERROR or REJECT is received:	17
5-1-2-2-3-1	Execute “Local Recovery Procedures” task (see 3.5.1).	18
5-1-2-2-4	WHEN timer (ISPRT) expires:	19
5-1-2-2-4-1	Execute “Local Recovery Procedures ” task (see 3.5.1).	20
5-1-2-2-4-2	Exit this task.	21
5-1-2-2-5	ENDWAIT.	22
5-1-2-3	ENDWHILE.	23
5-1-2-4	Stop timer (ISPRT).	24
5-1-3	ENDIF.	25
5-2	ELSE:	26
5-2-1	Execute “Local Recovery Procedures ” task (see 3.5.1).	27
5-2-2	Remain in this state.	28
5-3	ENDIF.	29
6	WHEN a RETURN ERROR or REJECT is received:	30
6-1	Execute “Local Recovery Procedures ” task (see 3.5.1).	31
6-2	IF other responses are expected:	32
6-2-1	Remain in this state.	33
6-3	ELSE:	34
6-3-1	Stop timer (ISPRT).	35
6-3-2	Include the AccessDeniedReason parameter set to <i>Termination Denied</i> .	36
6-3-3	Pass a Intersystem Page Notification to the waiting page in the process that spawned this task (the “Page an MS Procedure” (see 3.3.3)).	37

1
2
3
4
5
6
7
8
9
10
11
12
13
14
15
16
17
18
19
20
21
22
23
24
25
26
27
28
29
30
31
32
33
34
35
36
37
38
39
40
41
42
43
44
45
46
47
48
49
50
51
52
53
54
55
56
57
58
59
60

- 1 6-3-4 Exit this task.
 2
 3 6-4 ENDIF.
 4 7 WHEN timer (ISPRT) expires:
 5 7-1 IF a response was received at all:
 6 7-1-1 Include the AccessDeniedReason parameter set to the stored response.
 7 7-2 ELSE:
 8 7-2-1 Include the AccessDeniedReason parameter set to *No Page Response* .
 9 7-3 ENDIF.
 10 7-4 Pass a Intersystem Page Notification to the waiting page in the process that
 11 spawned this task (the “Page an MS Procedure” (see 3.3.3)).
 12 7-5 Execute “Local Recovery Procedures” task (see 3.5.1).
 13 8 ENDWAIT.
 14 9 Exit this task.

4.25.2 MSC Receiving InterSystemPage

When an MSC receives an InterSystemPage INVOKE, it shall perform the following:

- 1 IF the received message can be processed:
 1-1 IF the MSC is currently executing the “MSC Detecting an Unsolicited Page Response” procedure:
 1-1-1 Exit this task.
 1-2 ENDIF.
 1-3 IF the MS is currently in a call or service process:
 1-3-1 Include AccessDeniedReason parameter set to *Busy* ¹.
 1-3-2 Send a RETURN RESULT to the requesting MSC.
 1-3-3 Exit this task.
 1-4 ELSEIF paging should be performed:
 1-4-1 Determine the area to page base on the receive LocationAreaID parameter.²
 1-4-2 Page the mobile.
 1-5 ELSE:
 1-5-1 Only listen for a page response.
 1-6 ENDIF.
 1-7 Start a page response timer.
 1-8 WAIT for an MS response:
 1-9 WHEN the page response is received:
 1-9-1 Stop the page response timer.

¹Handling of Call Waiting in this situation is for further study.

²The paging area, identified by the location area ID, is defined per inter-system agreement.

1-9-2	IF the Border MSC needs to retrieve the MS's qualification information, optionally:	1
		2
1-9-2-1	Execute "MSC Initiating a Qualification Request" task (see 4.33.1).	3
		4
1-9-3	ENDIF.	5
		6
1-9-4	Process the MS presence confirmation procedure . ³	7
		8
1-9-5	IF the MS presence confirmation fails:	9
1-9-5-1	Include the AccessDeniedReason parameter set to <i>No Page Response</i> .	10
1-9-5-2	Send a RETURN RESULT.	11
1-9-5-3	Exit this task.	12
		13
1-9-6	ELSE (the presence confirmation is successful):	14
1-9-6-1	Execute "MSC Initiating an Authentication Request" task (see 4.4.1) to authenticate the MS.	15
		16
1-9-6-2	IF the MS is authentic:	17
		18
1-9-6-2-1	IF a TLDN is available:	19
1-9-6-2-1-1	Assign a TLDN to the indicated MS.	20
		21
1-9-6-2-1-2	Assign a billing identifier to the TLDN.	22
		23
1-9-6-2-1-3	Store the Originating MSC ID information and information related to the indicated MS with the assigned TLDN.	24
		25
1-9-6-2-1-4	Include the MSCID parameter set to the identity of the MSC.	26
1-9-6-2-1-5	Include the Digits (Destination) parameter set to the assigned TLDN.	27
		28
1-9-6-2-1-6	Include the BillingID (Serving) parameter set to the TLDN billing identifier.	29
		30
1-9-6-2-1-7	Send a RETURN RESULT.	31
		32
1-9-6-2-1-8	Execute "MSC Initiating MS Registration" task (see 4.38.1) to properly register the MS.	33
		34
1-9-6-2-1-9	Execute the "Wait for TLDN Call" task (see 3.3.2).	35
		36
1-9-6-2-2	ELSE (no TLDN is available):	37
1-9-6-2-2-1	Execute "Local Recovery Procedures" task (see 3.5.1).	38
		39
1-9-6-2-2-2	Include the Error Code parameter set to <i>ResourceShortage</i> .	40
1-9-6-2-2-3	Send a RETURN ERROR.	41
		42
1-9-6-2-3	ENDIF.	43
		44
1-9-6-3	ELSE (MS is not authentic):	45
1-9-6-3-1	Execute "Local Recovery Procedures" task (see 3.5.1).	46
		47
1-9-6-3-2	Exit this task.	48
		49
1-9-6-4	ENDIF.	50
		51
1-9-7	ENDIF.	52
		53
1-10	WHEN the page response timer expires:	54
1-10-1	Include the AccessDeniedReason parameter set to <i>No Page Response</i> .	55

³MS presence confirmation consists of paging the MS and voice channel assignment with either SAT detection or voice channel audit.

- 1-10-2 Send a RETURN RESULT.
 1-11 ENDWAIT.
 2 ELSE (the received message cannot be processed):
 2-1 Execute "Local Recovery Procedures " task (see 3.5.1).
 2-2 Send a RETURN ERROR with a proper Error Code value (see the following table).
 3 ENDIF.
 4 Exit this task.

Table 34 Border MSC InterSystemPage Response

Problem Detection and Recommended Response from Border MSC to Visited MSC										
PROBLEM DEFINITION	1	2	3	4	5	6	7	8	9	Notes
RETURN ERROR Error Code										
<i>UnrecognizedMIN</i>							X			
<i>UnrecognizedESN</i>							X			
<i>MIN/HLRMismatch</i>										a
<i>OperationSequenceProblem</i>										a
<i>ResourceShortage</i>		X								
<i>OperationNotSupported</i>	X									b
<i>TrunkUnavailable</i>										a
<i>ParameterError</i>					X					d
<i>SystemFailure</i>			X							
<i>UnrecognizedParameterValue</i>				X						d
<i>FeatureInactive</i>										a
<i>MissingParameter</i>						X				d
RETURN RESULT AccessDeniedReason										c
<i>Unassigned directory number</i>										a
<i>Inactive</i>										a
<i>Busy</i>								X		
<i>Termination Denied</i>									X	
<i>No Page Response</i>									X	
<i>Unavailable</i>									X	

Problem Detections:

- The requested MAP operation is recognized, but not supported by the receiving MSC or the requesting functional entity is not authorized.
- A required Border MSC resource (e.g., internal memory record, MSC is fully occupied) is temporarily not available (e.g., congestion).
- A required resource (e.g., data base access, functional entity) is not presently accessible due to a failure. Human intervention may be required for resolution.
- A supplied parameter value is unrecognized or has nonstandard values (e.g., *Not used*, the supplied MobileIdentificationNumber parameter digit values do not meet the expected BCD specification).
- Two or more mutually exclusive optional parameters have been supplied.
- An optional parameter required by the Border MSC was expected, but not received.
- The supplied ElectronicSerialNumber parameter is not valid for the recognized MIN's record or the ESN is on a negative list. The MIN is not recognized (e.g., no roaming agreement for that MIN).

8. The `MobileIdentificationNumber` parameter identified is currently active in a call.
9. The `MobileIdentificationNumber` parameter identified did not respond to an air-interface page message (No Page Response), is presently inactive (Unavailable) or is not able to accept call deliveries (Termination Denied).

Notes:

- a. This Error Code or `AccessDeniedReason` is not an appropriate Border MSC response to an `InterSystemPage` transaction.
- b. It is recommended that an MSC supports `InterSystemPage` transactions.
- c. Only the RETURN RESULT operations needing clarification have been included.
- d. Include the *Parameter Identifier* in question as the `FaultyParameter` parameter.

4.26 INTERSYSTEM PAGE 2

4.26.1 MSC Initiating an `InterSystemPage2`

When an MSC determines that it needs to request its neighboring MSC(s) to find an MS which has a pending call delivery, it shall perform the following:

- 1 For each neighboring MSC identified, according to the MSC's *topographical map* and the location area where the MS was last registered:
 - 1-1 Include the `LocationAreaID` parameter.
 - 1-2 Include the `PageIndicator` parameter set to indicate whether paging should occur or whether the MSC should only listen for a page response.
 - 1-3 Send an `InterSystemPage2` INVOKE to the neighboring MSC.
- 2 ENDFOR.
- 3 Start the Intersystem Page 2 Request Timer (ISPRT) as indicated in the MSC's internal parameters table.
- 4 WAIT for an intersystem page response:
- 5 WHEN a RETURN RESULT is received:
 - 5-1 IF the message can be processed:
 - 5-1-1 IF `AccessDeniedReason` parameter is received:
 - 5-1-1-1 IF the `AccessDeniedReason` is *Busy*, then:
 - 5-1-1-1-1 Continue the process which invoked this task.
 - 5-1-1-1-2 WHILE other responses are expected:
 - 5-1-1-1-2-1 WAIT for outstanding intersystem page responses:
 - 5-1-1-1-2-2 WHEN a RETURN RESULT is received:
 - 5-1-1-1-2-2-1 (Ignore it.)
 - 5-1-1-1-2-3 WHEN a RETURN ERROR or REJECT is received:
 - 5-1-1-1-2-3-1 Execute "Local Recovery Procedures" task (see 3.5.1).
 - 5-1-1-1-2-4 WHEN timer (ISPRT) expires:
 - 5-1-1-1-2-4-1 Execute "Local Recovery Procedures" task (see 3.5.1).
 - 5-1-1-1-2-4-2 Exit this task.
 - 5-1-1-1-2-5 ENDWAIT.
 - 5-1-1-1-3 ENDWHILE.

1 5-1-1-2 ELSEIF there is an outstanding response expected from at least one other
2 neighboring MSC:
3
4 5-1-1-2-1 Remain in this state.
5 5-1-1-3 ELSE:
6 5-1-1-3-1 Stop timer (ISPRT).
7 5-1-1-3-2 Continue with the process which invoked this task.
8 5-1-1-4 ENDIF.
9
10 5-1-2 ENDIF.
11
12 5-2 ENDIF.
13
14 6 WHEN a RETURN ERROR or REJECT is received:
15 6-1 Stop timer (ISPRT).
16 6-2 IF there is an outstanding response expected from a neighboring system, wait for
17 the response.
18 6-2-1 Remain in this state.
19 6-3 ELSE:
20 6-3-1 Execute “Local Recovery Procedures ” task (see 3.5.1).
21 6-3-2 Exit this task.
22 6-4 ENDIF.
23
24 7 WHEN the timer (ISPRT) expires:
25 7-1 Execute “Local Recovery Procedures ” task (see 3.5.1).
26 7-2 Exit this task.
27
28 8 ENDWAIT.
29
30 9 IF a response is outstanding:
31 9-1 WAIT for remaining intersystem page response(s):
32 9-2 WHEN a RETURN RESULT or REJECT is received:
33 9-2-1 (Ignore the message).
34 9-2-2 IF other responses are outstanding:
35 9-2-2-1 Remain in this state.
36 9-2-3 ELSE:
37 9-2-3-1 Stop timer (ISPRT).
38 9-2-4 ENDIF.
39 9-3 WHEN the timer (ISPRT) expires:
40 9-3-1 Execute “Local Recovery Procedures ” task (see 3.5.1).
41 9-4 ENDWAIT.
42
43 10 ENDIF.
44
45 11 IF authentication parameters were received,
46 11-1 Determine the value of the RandomVariable (RAND) used by the MS to
47 compute its AuthenticationResponse (AUTHR) .
48 11-2 IF the value of RandomVariable (RAND) cannot be determined,
49 11-2-1 Enter the “MSC Initiating a Security Status Report” task with a ReportType
50 parameter value of *RANDC mismatch*.
51 11-2-2 Exit this task with an *Authentication Failed* indication.
52
53
54
55
56
57
58
59
60

11-3	ELSE:	1
11-3-1	Start the Authentication Request Timer (ART).	2
11-3-2	Relay the received authentication parameters (i.e., CallHistoryCount (COUNT), AuthenticationResponse (AUTHR), RandomVariable (RAND), SystemAccessType).	3
		4
		5
		6
11-3-3	Send an AuthenticationRequest INVOKE to the MSC's associated VLR.	7
		8
11-3-4	WAIT for an authentication response:	9
11-3-5	WHEN RETURN ERROR or REJECT is received:	10
11-3-5-1	Execute "Local Recovery Procedures " task (see 3.5.1).	11
11-3-5-2	Exit this task with an <i>Authentication Failed</i> indication.	12
		13
11-3-6	WHEN a RETURN RESULT is received,	14
11-3-6-1	Stop timer ART.	15
		16
11-3-6-2	IF the message can be processed:	17
11-3-6-2-1	Execute the "MSC Initiating an Intersystem Setup" task (see 4.27.1).	18
11-3-6-2-2	IF the RandomVariableUniqueChallenge (RANDU) is received:	19
11-3-6-2-2-1	Include the RandomVariableUniqueChallenge (RANDU) and the AuthenticationResponseUnique (AUTHU) parameters set to the values received in the Authentication Request RETURN RESULT.	20
		21
		22
		23
		24
		25
11-3-6-2-2-2	Execute the "Anchor MSC Initiating an AuthenticationDirective Forward" task (see 4.2.1).	26
		27
		28
11-3-6-2-2-3	Execute the "MSC Initiating an Authentication Status Report" task (see 4.5.1) with a UniqueChallengeReport parameter value of <i>Unique Challenge successful</i> , <i>Unique Challengefailed</i> or <i>Unique Challenge not attempted</i> .	29
		30
		31
		32
11-3-6-2-3	ENDIF.	33
		34
11-3-6-3	ENDIF.	35
11-3-7	ENDWAIT.	36
11-4	ENDIF.	37
		38
12	ENDIF.	39
		40
13	Exit this task.	41
		42

4.26.2 MSC Receiving InterSystemPage2

When an MSC receives an InterSystemPage2 INVOKE, it shall perform the following:

- 1 IF the received message can be processed:
 - 1-1 IF the MSC is currently executing the "MSC Detecting an Unsolicited Page Response" task (see 4.54.1):
 - 1-1-1 Exit this task.
 - 1-2 ENDIF.
 - 1-3 IF the MS is currently in a call:

- 1-3-1 Include the AccessDeniedReason parameter indicating *Busy*.¹
- 1-3-2 Send an InterSystemPage2 RETURN RESULT to the requesting MSC.
- 1-3-3 Exit this task.
- 1-4 ELSEIF paging should be performed:
- 1-4-1 Determine the area to page based on the received LocationAreaID parameter.²
- 1-4-2 Page the mobile.
- 1-5 ELSE:
- 1-5-1 Only listen for a page response.
- 1-6 ENDIF.
- 1-7 Start a page response timer.
- 1-8 WAIT for the MS to respond to the page:
- 1-9 WHEN the page response is received:
- 1-9-1 Process the MS presence confirmation procedure.³
- 1-9-2 IF the MS presence confirmation fails:
- 1-9-2-1 Include the AccessDeniedReason parameter indicating *No Page Response*.
- 1-9-2-2 Send an InterSystemPage2 Request RETURN RESULT.
- 1-9-2-3 Exit this task.
- 1-9-3 ELSE (the MS presence confirmation is successful):
- 1-9-3-1 IF authentication parameters were received from the MS:
- 1-9-3-1-1 Include the SystemAccessType parameter set to *Page response*.
- 1-9-3-1-2 Include the CallHistoryCount (COUNT), and AuthenticationResponse (AUTHR) parameters provided by the MS.
- 1-9-3-1-3 Determine the value of the RandomVariable (RAND) used by the MS to compute its AuthenticationResponse (AUTHR) (see Annex A “Procedures for RANDC Verification”).
- 1-9-3-1-4 If the value of RandomVariable (RAND) cannot be determined:
- 1-9-3-1-4-1 Include the RANDC parameter provided by the MS.
- 1-9-3-1-5 ELSE (the value of RandomVariable (RAND) can be determined):
- 1-9-3-1-5-1 Include the RandomVariable (RAND) parameter used by the MS to compute the AuthenticationResponse (AUTHR) parameter.
- 1-9-3-1-6 ENDIF.
- 1-9-3-2 ENDIF.
- 1-9-3-3 Send an InterSystemPage2 RETURN RESULT to the requesting MSC.
- 1-9-3-4 Start the Intersystem Setup Wait Timer (ISSWT).

¹ Handling of Call Waiting in this situation is for further study.

²The paging area, identified by the location area ID, is defined per inter-system agreement.

³MS presence confirmation consists of paging the MS and voice channel assignment with either SAT detection or voice channel audit.

1-9-3-5	WAIT for an InterSystemSetup INVOKE:	1
1-9-3-6	WHEN the InterSystemSetup INVOKE message is received.	2
1-9-3-6-1	Stop timer (ISSWT).	3
1-9-3-6-2	Execute the “MSC Receiving InterSystemSetup INVOKE” task (see 4.27.2).	4
1-9-3-6-3	Exit this task.	5
1-9-3-7	WHEN the (ISSWT) timer expires.	6
1-9-3-7-1	Release the MS from the voice channel.	7
1-9-3-7-2	Execute “Local Recovery Procedures” task (see 3.5.1).	8
1-9-3-7-3	Exit this task.	9
1-9-3-8	ENDWAIT.	10
1-9-4	ENDIF.	11
1-10	WHEN the page response timer expires:	12
1-10-1	Include the AccessDeniedReason parameter indicating <i>No Page Response</i> .	13
1-10-2	Send an InterSystemPage2 Request RETURN RESULT.	14
1-10-3	Exit this task.	15
1-11	ENDWAIT.	16
2	ELSE (received message cannot be processed):	17
2-1	Send an InterSystemPage2 RETURN ERROR with a proper Error Code value to the requesting MSC.	18
3	ENDIF.	19
4	Exit this task.	20
		21
		22
		23
		24
		25
		26
		27
		28
		29
		30
		31
		32
		33
		34
		35
		36
		37
		38
		39
		40
		41
		42
		43
		44
		45
		46
		47
		48
		49
		50
		51
		52
		53
		54
		55
		56
		57
		58
		59
		60

Table 35 Border MSC InterSystemPage2 Response

Problem Detection and Recommended Response Border MSC to Visited MSC											
PROBLEM DEFINITION	1	2	3	4	5	6	7	8	9	10	Notes
RETURN ERROR											
Error Code											
<i>UnrecognizedMIN</i>							X				
<i>UnrecognizedESN</i>							X				
<i>MIN/HLRMismatch</i>											a
<i>OperationSequenceProblem</i>								X			
<i>ResourceShortage</i>		X									
<i>OperationNotSupported</i>	X										b
<i>TrunkUnavailable</i>											a
<i>ParameterError</i>					X						d
<i>SystemFailure</i>			X								
<i>UnrecognizedParameterValue</i>				X							d
<i>FeatureInactive</i>											a
<i>MissingParameter</i>						X					d
RETURN RESULT									X		c
RETURN RESULT											c
<i>AccessDeniedReason</i>											
<i>Unassigned directory number</i>											a
<i>Inactive</i>											a
<i>Busy</i>										X	
<i>Termination Denied</i>											
<i>No Page Response</i>											
<i>Unavailable</i>											

Problem Detections:

1. The requested MAP operation is recognized, but not supported by the receiving MSC or the requesting functional entity is not authorized.
2. A required Border MSC resource (e.g., internal memory record, MSC is fully occupied) is temporarily not available (e.g., congestion).
3. A required resource (e.g., data base access, functional entity) is not presently accessible due to a failure. Human intervention may be required for resolution.
4. A supplied parameter value is unrecognized or has nonstandard values (e.g., *Not used*, the supplied MobileIdentificationNumber parameter digit values do not meet the expected BCD specification).
5. Two or more mutually exclusive optional parameters have been supplied.
6. An optional parameter required by the Border MSC was expected, but not received.
7. The supplied ElectronicSerialNumber parameter is not valid for the recognized MIN's record.
8. The supplied MobileIdentificationNumber and ElectronicSerialNumber is currently registered in the Border MSC.
9. An UnsolicitedResponse procedure is currently active for the MIN identified.
10. The MobileIdentificationNumber parameter identified is currently active in a call.

Notes:

- a. This Error Code or AccessDeniedReason is not an appropriate Border MSC response to an InterSystemPage2 transaction.
- b. It is recommended that an MSC supports InterSystemPage2 transactions.
- c. Only the RETURN RESULT operations needing clarification have been included.
- d. Include the *Parameter Identifier* in question as the FaultyParameter parameter.

4.27 INTERSYSTEM SETUP

4.27.1 MSC Initiating an Intersystem Setup

When an MSC determines that it needs to perform call setup actions with a bordering MSC, it shall perform the following:

- 1 Select an intersystem trunk.
- 2 IF the call path cannot be successfully connected to the intersystem trunk:
 - 2-1 Release the intersystem trunk.
 - 2-2 Execute “Local Recovery Procedures” task (see 3.5.1).
 - 2-3 Exit this task.
- 3 ENDIF.
- 4 IF the MSC counts tandem segments:
 - 4-1 Set the Segment Counter field in the BillingID parameter to 1 (to reflect no air segments and one tandem segment).
- 5 ELSE:
 - 5-1 Set the Segment Counter field in the BillingID parameter to 0 (to reflect no air or tandem segments).
- 6 Include the BillingID parameter.
- 7 ENDIF.
- 8 Include the MS’s ElectronicSerialNumber and MobileIdentificationNumber parameters.
- 9 Include the InterMSCCircuitID parameter of the intersystem setup trunk facility.
- 10 IF the SignalingMessageEncryptionKey (SMEKEY) is available:
 - 10-1 Include the SignalingMessageEncryptionKey (SMEKEY) parameter.
- 11 ENDIF.
- 12 IF the MS is authorized to have Voice Privacy:
 - 12-1 IF the CDMAPrivateLongCodeMask (CDMAPLCM) is available:
 - 12-1-1 Include the CDMAPrivateLongCodeMask (CDMAPLCM) parameter.
 - 12-2 ELSEIF the VoicePrivacyMask (VPMASK) is available:
 - 12-2-1 Include the VoicePrivacyMask (VPMASK) parameter.
 - 12-3 ENDIF.
- 13 ENDIF.
- 14 Start the Intersystem Setup Timer (ISSRT).
- 15 Send an InterSystemSetup INVOKE to the bordering MSC.
- 16 WAIT for an intersystem setup response.
- 17 WHEN a RETURN RESULT is received:
 - 17-1 Stop timer (ISSRT).
 - 17-2 IF the message can be processed:
 - 17-2-1 Execute the “MSC Awaiting InterSystemAnswer” task (see 4.24.1).

- 1 17-3 ELSE:
 2 17-3-1 Release the intersystem trunk.
 3 17-3-2 Execute “Local Recovery Procedures” task (see 3.5.1).
 4 17-4 ENDIF.
 5 18 WHEN a RETURN ERROR or REJECT is received:
 6 18-1 Stop timer (ISSRT).
 7 18-2 Release the intersystem trunk.
 8 18-3 Execute “Local Recovery Procedures ” task (see 3.5.1).
 9 19 WHEN the timer (ISSRT) expires:
 10 19-1 Release the intersystem trunk.
 11 19-2 Execute “Local Recovery Procedures ” task (see 3.5.1).
 12 20 ENDWAIT.
 13 21 Exit this task.

4.27.2 MSC Receiving InterSystemSetup INVOKE

When an MSC receives an InterSystemSetup INVOKE, it shall perform the following:

- 1 IF the received message cannot be processed:
 1-1 Release the MS from the voice channel.
 1-2 Send an InterSystemSetup RETURN ERROR with a proper Error Code value to the requesting MSC.
 1-3 Execute “Local Recovery Procedures ” task (see 3.5.1).
 2 ELSEIF the voice path between the voice channel and the intersystem trunk cannot be successfully completed:
 2-1 Release the MS from the voice channel.
 2-2 Include the SetupResult parameter set to *Unsuccessful*.
 2-3 Send an InterSystemSetup RETURN RESULT.
 2-4 Execute “Local Recovery Procedures ” task (see 3.5.1).
 3 ELSEIF the MS cannot be successfully alerted:
 3-1 Disconnect the voice path.
 3-2 Release the MS from the voice channel.
 3-3 Include the SetupResult parameter set to *Unsuccessful* .
 3-4 Send an InterSystemSetup RETURN RESULT.
 3-5 Execute “Local Recovery Procedures ” task (see 3.5.1).
 4 ELSE (both voice path completion and MS alert are successful):
 4-1 Include the InterSwitchCount parameter set to 1.
 4-2 Include the SetupResult parameter set to *Successful* .
 4-3 Send an InterSystemSetup RETURN RESULT.
 4-4 IF Voice Privacy is desired AND IF the system supports Voice Privacy:
 4-4-1 Order the MS to enable Voice Privacy.
 4-5 ENDIF.

- 4-6 IF Signaling Message Encryption is desired AND IF the system supports Signaling Message Encryption:
- 4-6-1 Order the MS to enable Signaling Message Encryption.
- 4-7 ENDIF.
- 5 ENDIF.
- 6 Exit this task.

Table 36 Border MSC InterSystemSetup Response

Problem Detection and Recommended Response from Border MSC to Visited MSC										
PROBLEM DEFINITION	1	2	3	4	5	6	7	8	9	Notes
RETURN ERROR Error Code										
<i>UnrecognizedMIN</i>								X		
<i>UnrecognizedESN</i>										a
<i>MIN/HLRMismatch</i>										a
<i>OperationSequenceProblem</i>									X	
<i>ResourceShortage</i>		X								
<i>OperationNotSupported</i>	X									b
<i>TrunkUnavailable</i>							X			
<i>ParameterError</i>					X					d
<i>SystemFailure</i>			X							
<i>UnrecognizedParameterValue</i>				X						d
<i>FeatureInactive</i>										a
<i>MissingParameter</i>						X				d
RETURN RESULT										c

Problem Detections:

1. The requested MAP operation is recognized, but not supported by the receiving MSC or the requesting functional entity is not authorized.
2. A required MSC resource is temporarily not available.
3. A required resource (e.g., data base access, functional entity) is not presently accessible due to a failure. Human intervention may be required for resolution.
4. Supplied parameter, (e.g., InterMSCCircuitID, BillingID) value is unrecognized or has nonstandard values or the MSC does not support the requested value (e.g., inter-MSC trunk circuit).
5. An unexpected parameter was received.
6. An optional parameter required by the MSC was expected, but not received.
7. The supplied InterMSCCircuitID parameter value is valid, but this trunk circuit is presently *Active*, *Locally Blocked*, or *Locally and Remotely Blocked*.
8. The supplied MobileIdentificationNumber parameter is not recognized as an authorized MS.
9. The supplied InterSwitchCount parameter value exceeds the defined *MAXHANDOFF* threshold value.

Notes:

- a. This Error Code is not an appropriate response to InterSystemSetup transaction.
- b. It is recommended that an MSC supports InterSystemSetup transactions.
- c. Only the RETURN RESULT operations needing clarification have been included.
- d. Include the *Parameter Identifier* in question as the *FaultyParameter* parameter.

1
2
3
4
5
6
7
8
9
10
11
12
13
14
15
16
17
18
19
20
21
22
23
24
25
26
27
28
29
30
31
32
33
34
35
36
37
38
39
40
41
42
43
44
45
46
47
48
49
50
51
52
53
54
55
56
57
58
59
60

4.28 LOCATION REQUEST

4.28.1 MSC Initiating a Location Request

When an MSC receives a call destined toward an MS and the received Directory Number (DN) is not a TLDN assigned by the MSC, it shall perform the following:

- 1 Include the MSCID (Originating) parameter set to the identity of the MSC.
- 2 Include the MSCIdentificationNumber parameter set to the identification number of the MSC.
- 3 Include the TerminationAccessType parameter set to the source of the request (e.g., PSTN, roamer port, private network trunk group).
- 4 Include the BillingID (Originating) parameter set to the billing identifier for the call assigned by the current Originating MSC.
- 5 Include the Digits (Dialed) parameter set to the dialed or called digits used to access a mobile subscriber. (This is the digits dialed after reaching a roamer port.)
- 6 Include the SystemMyTypeCode parameter set to the manufacturer of the Originating MSC.
- 7 Include the TransactionCapability parameter indicating the MSC's capability for this transaction.
- 8 IF the network validated calling party number is known:
 - 8-1 Include the CallingPartyNumberDigits1 parameter.
 - 9 ENDIF.
 - 10 IF the user provided calling party number is known:
 - 10-1 Include the CallingPartyNumberDigits2 parameter.
 - 11 ENDIF.
 - 12 IF the calling party subaddress is known:
 - 12-1 Include the CallingPartySubaddress parameter.
 - 13 ENDIF.
 - 14 IF the message is to be launched on an SS7 network:
 - 14-1 IF the MSC is the home MSC for the indicated directory number:
 - 14-1-1 Include the PC_SSN parameter with the Type set to *Home MSC* and the PC and SSN fields set to the MSC's point code and subsystem number.
 - 14-2 ELSE:
 - 14-2-1 Include the PC_SSN parameter with the Type set to *Originating MSC* and the PC and SSN fields set to the MSC's point code and subsystem number.
 - 14-3 ENDIF.
 - 15 ENDIF.
 - 16 IF the received call was redirected (before arrival to the Originating MSC):
 - 16-1 IF the redirecting number is known:
 - 16-1-1 Include the RedirectingNumberDigits parameter.
 - 16-2 ENDIF.
 - 16-3 IF the redirecting subaddress is known:

16-3-1	Include the RedirectingSubaddress parameter.	1
16-4	ENDIF.	2
17	ENDIF.	3
18	Optionally provide call progress tone or announcement to the caller.	4
19	Send a LocationRequest INVOKE to the indicated MS's HLR.	5
20	Start the Location Request Timer (LRT).	6
21	WAIT for a Location Request response:	7
22	WHEN a RETURN RESULT is received:	8
22-1	Stop timer (LRT).	9
22-2	IF the message can be processed:	10
22-2-1	IF the incoming call is still connected:	11
22-2-1-1	IF the OneTimeFeatureIndicator parameter is received:	12
22-2-1-1-1	Store the OneTimeFeatureIndicator parameter to modify subsequent call processing actions for this call.	13
22-2-1-2	ENDIF.	14
22-2-1-3	IF the AccessDeniedReason parameter is received:	15
22-2-1-3-1	IF the AccessDeniedReason parameter can be acted upon:	16
22-2-1-3-1-1	IF the AnnouncementList parameter is received:	17
22-2-1-3-1-1-1	Execute the "Play All Announcements in theAnnouncementList" task (see 3.2.5).	18
22-2-1-3-1-1-2	Optionally provide the treatment indicated in the AccessDeniedReason parameter.	19
22-2-1-3-1-2	ELSE:	20
22-2-1-3-1-2-1	Provide the treatment indicated in the AccessDeniedReason parameter.	21
22-2-1-3-1-3	Exit this task.	22
22-2-1-3-1-4	ENDIF.	23
22-2-1-3-2	ENDIF.	24
22-2-1-4	ENDIF.	25
22-2-1-5	IF the Digits (Destination) parameter is included:	26
22-2-1-5-1	IF the AnnouncementList parameter is received:	27
22-2-1-5-1-1	Execute the "Play All Announcements in theAnnouncementList" task (see 3.2.5).	28
22-2-1-5-2	ELSE:	29
22-2-1-5-2-1	Optionally provide call progress tones or announcements to the calling party.	30
22-2-1-5-3	ENDIF.	31
22-2-1-5-4	Execute the "MSC Route the Call Leg Externally" task (see 3.3.8).	32
22-2-1-6	ELSEIF the TerminationList parameter is included:	33
22-2-1-6-1	IF the AnnouncementList parameter is received:	34
22-2-1-6-1-1	Execute the "Play All Announcements in the AnnouncementList" task (see 3.2.5).	35
22-2-1-6-2	ELSE:	36
		37
		38
		39
		40
		41
		42
		43
		44
		45
		46
		47
		48
		49
		50
		51
		52
		53
		54
		55
		56
		57
		58
		59
		60

4.28.2 HLR Receiving LocationRequest INVOKE

When an HLR receives a LocationRequest INVOKE, it shall perform the following:¹

- 1 IF the received message can be processed:
 - 1-1 (Execute feature incoming call tasks to determine the feature processing and PointOfReturn.)
 - 1-2 IF the CallingPartyNumberDigits1 parameter was received:
 - 1-2-1 IF the received Digits (Dialed) equal the CallingPartyNumberDigits1 (an MS dialed its own directory number):
 - 1-2-1-1 CASE revertive treatment OF:
 - 1-2-1-2 *VMR*:
 - 1-2-1-2-1 Execute “HLR VMR Revertive Call Invocation” task (see 5.23.3).
 - 1-2-1-3 *FA*:
 - 1-2-1-3-1 Execute “HLR FA Revertive Call Invocation” task (see 5.12.4).
 - 1-2-1-4 *MAH*:
 - 1-2-1-4-1 Execute “HLR MAH Revertive Call Invocation” task (see 5.14.5).
 - 1-2-1-5 *DEFAULT*:
 - 1-2-1-5-1 Include the AnnouncementCode parameter within the AnnouncementList set to an accessed denied announcement.
 - 1-2-1-5-2 Set the PointOfReturn to ToneTermination.
 - 1-2-1-6 ENDCASE.
 - 1-2-1-7 Send a RETURN RESULT to the requesting MSC.
 - 1-2-1-8 Exit this task.
 - 1-2-2 ENDIF.
 - 1-3 ENDIF.
 - 1-4 Set the called or dialed party equal to the received Digits (Dialed) parameter.
 - 1-5 Execute the “HLR FA Incoming Call Invocation” task (see 5.12.3).
 - 1-6 IF the PointOfReturn is indicated:
 - 1-6-1 GOTO LocReqPointOfReturn.
 - 1-7 ENDIF.
 - 1-8 Execute the “HLR MAH Incoming Call Invocation” task (see 5.14.4).
 - 1-9 IF the PointOfReturn is indicated:
 - 1-9-1 GOTO LocReqPointOfReturn.
 - 1-10 ENDIF.
 - 1-11 Execute the “HLR CFU Incoming Call Invocation” task (see 5.5.5).
 - 1-12 IF the PointOfReturn is indicated:
 - 1-12-1 GOTO LocReqPointOfReturn.

¹Note that the feature interaction is per *IS-53* and may be different in actual implementations.

1 1-13 ENDIF.
2
3 1-14 Execute the “HLR SCA Incoming Call Invocation” task (see 5.19.7).
4 1-15 IF the PointOfReturn is indicated:
5 1-15-1 IF the PointOfReturn is *Accepted* :
6 1-15-1-1 GOTO Call Accepted.
7
8 1-15-2 ELSE:
9 1-15-2-1 GOTO LocReqPointOfReturn.
10 1-15-3 ENDIF.
11
12 1-16 ENDIF.
13
14 1-17 Execute the “HLR PCA Incoming Call Invocation” task (see 5.15.7).
15 1-18 IF the PointOfReturn is indicated:
16 1-18-1 IF the PointOfReturn is *Accepted* :
17 1-18-1-1 GOTO Call Accepted.
18 1-18-2 ELSE:
19 1-18-2-1 GOTO LocReqPointOfReturn.
20 1-18-3 ENDIF.
21
22 1-19 ENDIF.
23
24
25
26 1-20 Execute the “HLR CFNA Incoming Call Invocation” task (see 5.4.5).
27 1-21 IF the PointOfReturn is indicated:
28 1-21-1 GOTO LocReqPointOfReturn.
29 1-22 ENDIF.
30
31 1-23 Execute the “HLR CFD Incoming Call Invocation” task (see 5.3.5).
32 1-24 IF the PointOfReturn is indicated:
33 1-24-1 GOTO LocReqPointOfReturn.
34 1-25 ENDIF.
35
36 1-26 Execute the “HLR DND Incoming Call Invocation” task (see 5.11.3).
37 1-27 IF the PointOfReturn is indicated:
38 1-27-1 GOTO LocReqPointOfReturn.
39 1-28 ENDIF.
40
41 (HLR-based features are complete at this point.)
42
43 1-29 IF termination to the MS is authorized:
44 1-29-1 Execute the “HLR CD Incoming Call Invocation” task (see 5.1.3).
45 1-29-2 IF the PointOfReturn is not indicated:
46 1-29-2-1 (This is the default treatment for LocationRequests.)
47 1-29-2-2 Include the AnnouncementCode parameter within the AnnouncementList
48 parameter set to Reorder or other appropriate announcement.
49 1-29-2-3 Set the PointOfReturn to *ToneTermination* (this is the default
50 treatment).
51 1-29-3 ENDIF.
52
53 1-30 ELSE (termination to the MS is not authorized):
54
55
56
57
58
59
60

1-30-1	Include the <code>AnnouncementCode</code> parameter in the <code>AnnouncementList</code> parameter set to an appropriate announcement.	1
		2
1-30-2	Set the <code>PointOfReturn</code> to <i>ToneTermination</i> .	3
		4
1-31	ENDIF.	5
	O (parameters may be included already and the <code>PointOfReturn</code> should be selected by the feature processing tasks)	6
		7
1-32	CASE <code>PointOfReturn</code> OF:	8
		9
1-33	<i>ToneTermination</i> :	10
		11
1-33-1	Include the <code>AccessDeniedReason</code> parameter set to the proper value (see the following table).	12
		13
1-33-2	Include the <code>MSCID</code> parameter set to the identity of the Originating MSC.	14
		15
1-34	<i>LocalTermination</i> :	16
		17
1-34-1	Include the <code>MSCID</code> parameter set to the identity of the Serving MSC.	18
		19
1-34-2	Execute the “HLR CNIP Terminating Call Invocation” task (see 5.8.1).	20
1-34-3	IF the a preferred interexchange carrier is applicable:	21
		22
1-34-3-1	Include the <code>Digits (Carrier)</code> parameter set to the MS’s preferred interexchange carrier.	23
		24
1-34-4	ENDIF.	25
1-35	<i>IntersystemTermination</i> :	26
		27
1-35-1	Include the <code>MSCID</code> parameter set to the identity of the Serving MSC.	28
		29
1-35-2	IF the <code>PC_SSN</code> of the Serving MSC is known:	30
		31
1-35-2-1	Include the <code>PC_SSN</code> parameter as received.	32
		33
1-35-3	ENDIF.	34
1-35-4	Execute the “HLR CNIP Redirecting Call Invocation” task (see 5.8.2).	35
		36
1-35-5	IF the a preferred interexchange carrier is applicable:	37
		38
1-35-5-1	Include the <code>Digits (Carrier)</code> parameter set to the MS’s preferred interexchange carrier.	39
		40
1-35-6	ENDIF.	41
1-36	<i>PSTNTermination</i> :	42
		43
1-36-1	Include the <code>MSCID</code> parameter set to the identity of the Originating MSC.	44
		45
1-36-2	IF selection of interexchange carrier is applicable:	46
		47
1-36-2-1	Include the <code>Digits (Carrier)</code> parameter set to the MS’s preferred interexchange carrier.	48
		49
1-36-3	ENDIF.	50
		51
1-36-4	Execute the “HLR CNIP Redirecting Call Invocation” task (see 5.8.2).	52
		53
1-36-5	IF the a preferred interexchange carrier is applicable:	54
		55
1-36-5-1	Include the <code>Digits (Carrier)</code> parameter set to the MS’s preferred interexchange carrier.	56
		57
1-36-6	ENDIF.	58
1-37	<i>MultipleTermination</i> :	59
		60
1-37-1	IF at least one of the routes on the list is for a <i>LocalTermination</i> :	
1-37-1-1	Execute the “HLR CNIP Terminating Call Invocation” task (see 5.8.1).	
1-37-2	ENDIF.	

- 1-37-3 IF at least one of the routes on the list is for a *InterSystemTermination* or a *PSTNTermination*:
- 1-37-3-1 Execute the “HLR CNIP Redirecting Call Invocation” task (see 5.8.2).
- 1-37-4 ENDIF.
- 1-37-5 IF the a preferred interexchange carrier is applicable:
- 1-37-5-1 Include the Digits (Carrier) parameter set to the MS’s preferred interexchange carrier.
- 1-37-6 ENDIF.
- 1-38 *DEFAULT*:
- 1-38-1 Send a RETURN ERROR with Error Code *SystemFailure*.
- 1-38-2 Exit this task.
- 1-39 ENDCASE.
- 1-40 Send a RETURN RESULT to the requesting MSC.
- 2 ELSE (the received message cannot be processed):
- 2-1 Send a RETURN ERROR with a proper Error Code value (see the following table) to the requesting MSC.
- 3 ENDIF.
- 4 Exit this task.

Table 37 HLR LocationRequest Response

Problem Detection and Recommended Response from HLR to Originating MSC											
PROBLEM DEFINITION	1	2	3	4	5	6	7	8	9	10	Notes
RETURN ERROR											
Error Code											
<i>UnrecognizedMIN</i>											a
<i>UnrecognizedESN</i>											a
<i>MIN/HLRMismatch</i>							X				
<i>OperationSequenceProblem</i>											a
<i>ResourceShortage</i>		X									
<i>OperationNotSupported</i>	X										b
<i>TrunkUnavailable</i>											a
<i>ParameterError</i>				X							d
<i>SystemFailure</i>			X								
<i>UnrecognizedParameterValue</i>					X						d
<i>FeatureInactive</i>											a
<i>MissingParameter</i>						X					d
RETURN RESULT											c
AccessDeniedReason											
<i>Unassigned directory number</i>								X			
<i>Inactive</i>									X		
<i>Busy</i>									X		
<i>Termination Denied</i>										X	
<i>No Page Response</i>									X		
<i>Unavailable</i>									X		

Problem Detections:

1. The requested MAP operation is recognized, but not supported, by the receiving HLR, or the requesting functional entity is not authorized.

2. A required HLR resource (e.g., internal memory record, HLR is fully occupied) is temporarily not available (e.g., congestion).
3. A required resource (e.g., data base access, functional entity) is not presently accessible due to a failure. Human intervention may be required for resolution.
4. A supplied parameter has an encoding problem (e.g., the Digits (Dialed) parameter has an inconsistent length, digits in the Digits (Dialed) parameter do not meet the BCD specification).
5. A supplied parameter value is unrecognized or has nonstandard values (e.g., *Not used*, the supplied Digits (Dialed) parameter contains an unexpected Code 11, Code 12, Spare, *, # or ST digit, the supplied Digits (Dialed) parameter is an unexpected length, the Digits (Dialed) parameter is using an unrecognized value for numbering plan, encoding, or type of digits).
6. An expected, or required, optional parameter (e.g., PC_SSN) was not received.
7. The supplied Digits (Dialed) parameter corresponds to a MobileDirectoryNumber that is not in the HLR's range of MINs or directory numbers (suspect routing error).
8. The supplied Digits (Dialed) parameter corresponds to a MobileDirectoryNumber that is within the range of the HLR, but the MobileDirectoryNumber is not presently assigned to an MS.
9. The supplied Digits (Dialed) parameter corresponds to an MS within the HLR, but the MS is either Inactive (powered down, failed to autonomously register, has call delivery deactivated), *Busy*, *No Page Response* or *Unavailable* and redirection (as Call Forwarding) does not apply.
10. The supplied Digits (Dialed) parameter corresponds to an MS within the HLR, but the MS has a restriction of Termination denied or is AuthorizationDenied (e.g., *Delinquent Account*, *Stolen Unit*, *Duplicate Unit*, or *Unspecified*).

Notes:

- a. This Error Code is not an appropriate HLR response to a LocationRequest transaction.
- b. It is recommended that an HLR supports LocationRequest transactions.
- c. Only RETURN RESULT operations needing clarification have been included.
- d. Include the *Parameter Identifier* in question as the FaultyParameter parameter.

4.29 MS ON CHANNEL

MS On Channel is part of the Section 4.11 Facility Directive procedures.

4.30 MS INACTIVE

4.30.1 MSC Initiating an MS Inactive

When the MSC detects an inactive MS, the Serving MSC shall do the following:

- 1 Include the MS's MobileIdentificationNumber and ElectronicSerialNumber parameters.
- 2 IF the MS is being de-registered:
 - 2-1 Include the MS's DeregistrationType parameter indicating the appropriate type.
 - 2-2 IF the *SMS Delivery Pending Flag* is set for this MS:
 - 2-2-1 Include the SMS_MessageWaitingIndicator parameter.
 - 2-3 ENDIF.
 - 2-4 Remove the MS's record.
- 3 ENDIF.

- 4 Include the MS's LocationAreaID parameter.
- 5 IF an identification number is assigned to the MSC:
 - 5-1 Include the SenderIdentificationNumber parameter set to the MSC's ID.
- 6 ENDIF.
- 7 Send an MSInactive INVOKE to the MSC's associated VLR.
- 8 Start the MS Inactive Timer (MSIT).
- 9 WAIT for an MS Inactive response:
 - 10 WHEN a RETURN RESULT is received:
 - 10-1 Stop timer (MSIT).
 - 10-2 IF the message cannot be processed:
 - 10-2-1 Execute the "Local Recovery Procedures" task (see 3.5.1).
 - 10-3 ENDIF.
 - 11 WHEN a RETURN ERROR or REJECT is received:
 - 11-1 Stop timer (MSIT).
 - 11-2 Execute the "Local Recovery Procedures " task (see 3.5.1).
 - 12 WHEN timer (MSIT) expires:
 - 12-1 Execute the "Local Recovery Procedures " task (see 3.5.1).
 - 13 ENDWAIT.
- 14 Exit this task.

4.30.2 VLR Receiving MSInactive INVOKE

When a VLR receives an MSInactive INVOKE, it shall perform the following:

- 1 IF the received message can be processed:
 - 1-1 Send a RETURN RESULT to the requesting MSC.
 - 1-2 Execute the "VLR Detection of MS Inactive" task (see 4.30.3).
- 2 ELSE (the received message cannot be processed):
 - 2-1 Send a RETURN ERROR with a proper Error Code value (see the following table) to the requesting MSC.
- 3 ENDIF.
- 4 Exit this task.

Table 38 VLR MSInactive Response

Problem Detection and Recommended Response from VLR to MSC-V								
PROBLEM DEFINITION	1	2	3	4	5	6	7	Notes
RETURN ERROR Error Code								
<i>UnrecognizedMIN</i>					X			
<i>UnrecognizedESN</i>						X		
<i>MIN/HLRMismatch</i>								a
<i>OperationSequenceProblem</i>							X	
<i>ResourceShortage</i>		X						
<i>OperationNotSupported</i>	X							b
<i>TrunkUnavailable</i>								a
<i>ParameterError</i>				X				d
<i>SystemFailure</i>			X					
<i>UnrecognizedParameterValue</i>								a
<i>FeatureInactive</i>								a
<i>MissingParameter</i>								a
RETURN RESULT								c

Problem Detections:

1. The requested MAP operation is recognized, but not supported, by the receiving VLR, or the requesting functional entity is not authorized.
2. A required VLR resource (e.g., internal memory record, VLR is fully occupied) is temporarily not available (e.g., congestion).
3. A required resource (e.g., data base access, functional entity) is not presently accessible due to a failure. Human intervention may be required for resolution.
4. A supplied parameter value has an encoding problem (e.g., The supplied MobileIdentificationNumber parameter digit values do not meet the BCD specification).
5. A VLR record does not presently exist for the supplied MobileIdentificationNumber parameter.
6. A VLR record exists for the supplied MobileIdentificationNumber parameter, but the supplied ElectronicSerialNumber parameter does not match the ESN in the VLR record.
7. A VLR record exists for the supplied MobileIdentificationNumber parameter, but the MIN is presently registered in another MSC.

Notes:

- a. This Error Code is not an appropriate VLR response to an MSInactive transaction.
- b. It is recommended that a VLR support MSInactive transactions.
- c. Only RETURN RESULT operations needing clarification have been included.
- d. Include the *Parameter Identifier* in question as the FaultyParameter parameter.

4.30.3 VLR Detection of MS Inactivity

When the VLR determines that an MS is inactive by receiving an MSInactive INVOKE from an MSC or based on internal algorithms, the VLR shall do the following:

- 1 Include the MS's ElectronicSerialNumber parameter.
- 2 Include the MS's MobileIdentificationNumber parameter.
- 3 Set the MS's state to inactive.
- 4 IF SharedSecretData (SSD) is shared for this MS:

- 1 4-1 IF the CallHistoryCount (COUNT) is available:
 2
 3 4-1-1 Include the CallHistoryCount (COUNT) parameter.
 4 4-2 ENDIF.
 5 5 ENDIF.
 6 6 IF the MS's record is to be removed from the VLR database:
 7
 8 6-1 Include the MS's DeregistrationType parameter set to the appropriate
 9 deregistration type (this may be relayed from the MSC).
 10 6-2 Remove the MS's record from the VLR's database.
 11 7 ENDIF.
 12 8 Include the MS's LocationAreaID parameter.
 13 9 IF an identification number is assigned to the VLR:
 14
 15 9-1 Include the SenderIdentificationNumber parameter set to the VLR's ID.
 16 10 ENDIF.
 17 11 IF the SMS_MessageWaitingIndicator parameter is received:
 18
 19 11-1 Relay the received SMS_MessageWaitingIndicator parameter.
 20 12 ENDIF.
 21 13 Send an MSInactive INVOKE to the MS's HLR.
 22 14 Start the MS Inactive Timer (MSIT).
 23 15 WAIT for an MS Inactive response.
 24 16 WHEN a RETURN RESULT is received:
 25
 26 16-1 Stop the timer (MSIT).
 27 17 WHEN a RETURN ERROR or REJECT is received:
 28
 29 17-1 Stop the timer (MSIT).
 30 17-2 Execute the "Local Recovery Procedures" task (see 3.5.1).
 31 18 WHEN the timer (MSIT) expires:
 32
 33 18-1 Execute the "Local Recovery Procedures" task (see 3.5.1).
 34 19 ENDWAIT.
 35 20 Exit this task.

4.30.4 HLR Receiving MSInactive INVOKE

When an HLR receives an MSInactive INVOKE, it shall perform the following:

- 1 IF the received message can be processed:
 2
 3 1-1 IF the MobileIdentificationNumber (MIN) and the ElectronicSerialNumber of
 4 a registered MS are equal to the received MobileIdentificationNumber and
 5 ElectronicSerialNumber parameters, AND IF the requesting VLR is the VLR
 6 serving the MS:
 7
 8 1-1-1 Set the MS's state to *inactive*.
 9 1-1-2 IF a DeregistrationType parameter is received:
 10 1-1-2-1 Clear the HLR's pointer to the VLR serving the MS.
 11 1-1-3 ENDIF.
 12 1-1-4 Send a RETURN RESULT to the requesting VLR.

1-1-5	IF the CallHistoryCount (COUNT) parameter is received:	1
1-1-5-1	Relay the received parameters.	2
1-1-5-2	Send an MSInactive INVOKE to the MS's AC.	3
1-1-5-3	Start the MS Inactive Timer (MSIT).	4
1-1-5-4	WAIT for an MS Inactive response.	5
1-1-5-5	WHEN a RETURN RESULT is received:	6
1-1-5-5-1	Stop the timer (MSIT).	7
1-1-5-6	WHEN a RETURN ERROR or REJECT is received:	8
1-1-5-6-1	Stop the timer (MSIT).	9
1-1-5-6-2	Execute the "Local Recovery Procedures" task (see 3.5.1).	10
1-1-5-7	WHEN the timer (MSIT) expires:	11
1-1-5-7-1	Execute the "Local Recovery Procedures " task (see 3.5.1).	12
1-1-5-8	ENDWAIT.	13
1-1-6	ENDIF.	14
1-1-7	IF the SMS_MessageWaitingIndicator parameter is received:	15
1-1-7-1	Set the <i>SMS Delivery Pending Flag</i> for this MS.	16
1-1-8	ENDIF.	17
1-2	ELSE (MIN-ESN mismatch or VLR mismatch):	18
1-2-1	Send a RETURN RESULT (see the following table) to the VLR.	19
1-3	ENDIF.	20
2	ELSE (the message cannot be processed):	21
2-1	Send a RETURN ERROR with the proper Error Code value (see the following table) to the VLR.	22
3	ENDIF.	23
4	Exit this task.	24
		25
		26
		27
		28
		29
		30
		31
		32
		33
		34
		35
		36
		37
		38
		39
		40
		41
		42
		43
		44
		45
		46
		47
		48
		49
		50
		51
		52
		53
		54
		55
		56
		57
		58
		59
		60

Table 39 HLR MSInactive Response

Problem Detection and Recommended Response from HLR to VLR										
PROBLEM DEFINITION	1	2	3	4	5	6	7	8	9	Notes
RETURN ERROR										
Error Code										
<i>UnrecognizedMIN</i>										a
<i>UnrecognizedESN</i>										a
<i>MIN/HLRMismatch</i>					X					
<i>OperationSequenceProblem</i>										a
<i>ResourceShortage</i>		X								
<i>OperationNotSupported</i>	X									b
<i>TrunkUnavailable</i>										a
<i>ParameterError</i>				X						d
<i>SystemFailure</i>			X							
<i>UnrecognizedParameterValue</i>										a
<i>FeatureInactive</i>										a
<i>MissingParameter</i>						X				
RETURN RESULT							X	X	X	c

Problem Detections:

1. The requested MAP operation is recognized, but not supported, by the receiving HLR, or the requesting functional entity is not authorized.
2. A required HLR resource (e.g., internal memory record, HLR is fully occupied) is temporarily not available (e.g., congestion).
3. A required resource (e.g., data base access, functional entity) is not presently accessible due to a failure. Human intervention may be required for resolution.
4. A supplied parameter value has an encoding problem (e.g., The supplied MobileIdentificationNumber parameter digit values do not meet the BCD specification).
5. The supplied MobileIdentificationNumber parameter is not in the HLR's range of MINs or directory numbers (suspect routing error).
6. An expected, or required, optional parameter (e.g., CallHistoryCount (COUNT), LocationAreaID, SenderIdentificationNumber) was not received.
7. The supplied MobileIdentificationNumber parameter is within the range of the HLR, but the MIN is an *Unassigned directory number* (not presently assigned to a subscriber), a *Delinquent Account*, *Stolen Unit*, *Duplicate Unit*, or *Unspecified*.
8. The supplied MobileIdentificationNumber parameter is within the range of the HLR, but the supplied ElectronicSerialNumber parameter is not valid for the MIN's record.
9. The supplied MobileIdentificationNumber parameter is within the range of the HLR, but the MIN is presently registered in another system.

Notes:

- a. This Error Code is not an appropriate HLR response to an MSInactive transaction.
- b. It is recommended that an HLR supports MSInactive transactions.
- c. These problems, though detected, are not included in the response.
- d. Include the *Parameter Identifier* in question as the FaultyParameter parameter.

4.30.5 AC Receiving MSInactive INVOKE

When an AC receives an MSInactive INVOKE, it shall perform the following:

- 1 IF the message can be processed:

- 1-1 IF SharedSecretData (SSD) is shared for the specified MS:
 - 1-1-1 IF the CallHistoryCount (COUNT) parameter was received:
 - 1-1-1-1 Update the MS's CallHistoryCount (COUNT).
 - 1-1-2 ENDIF.
 - 1-1-3 Send a RETURN RESULT to the requesting HLR.
 - 1-2 ENDIF.
- 2 ELSE (the received message cannot be processed):
 - 2-1 Send a RETURN ERROR to the requesting HLR.
 - 3 ENDIF.
 - 4 Exit this task.

1
2
3
4
5
6
7
8
9
10
11
12
13
14
15
16
17
18
19
20
21
22
23
24
25
26
27
28
29
30
31
32
33
34
35
36
37
38
39
40
41
42
43
44
45
46
47
48
49
50
51
52
53
54
55
56
57
58
59
60

Table 40 AC MSInactive Response

Problem Detection and Recommended Response from AC to HLR									
PROBLEM DEFINITION	1	2	3	4	5	6	7	8	Notes
RETURN ERROR									
Error Code									
<i>UnrecognizedMIN</i>					X				
<i>UnrecognizedESN</i>									a
<i>MIN/HLRMismatch</i>									a
<i>OperationSequenceProblem</i>									a
<i>ResourceShortage</i>		X							
<i>OperationNotSupported</i>	X								b
<i>TrunkUnavailable</i>									a
<i>ParameterError</i>				X					d
<i>SystemFailure</i>			X						
<i>UnrecognizedParameterValue</i>									a
<i>FeatureInactive</i>									a
<i>MissingParameter</i>						X			
RETURN RESULT							X	X	c

Problem Detections:

1. The requested MAP operation is recognized, but not supported, by the receiving AC, or the requesting functional entity is not authorized.
2. A required AC resource (e.g., internal memory record, AC is fully occupied) is temporarily not available (e.g., congestion).
3. A required resource (e.g., data base access, functional entity) is not presently accessible due to a failure. Human intervention may be required for resolution.
4. A supplied parameter value has an encoding problem (e.g., The supplied MobileIdentificationNumber parameter digit values do not meet the BCD specification).
5. The supplied MobileIdentificationNumber parameter is not in the AC's range of MINs or directory numbers (suspect routing error).
6. An expected, or required, optional parameter (e.g., CallHistoryCount (COUNT)) was not received.
7. The supplied MobileIdentificationNumber parameter is within the range of the AC, but the MIN is not Authentication capable or authorized.
8. The supplied MobileIdentificationNumber parameter is within the range of the AC, but the supplied ElectronicSerialNumber parameter is not valid for the MIN's authentication record.

Notes:

- a. This Error Code is not an appropriate AC response to an MSInactive transaction.
- b. It is recommended that an AC supports MSInactive transactions.
- c. These problems, though detected, are not included in the response.
- d. Include the *Parameter Identifier* in question as the FaultyParameter parameter.

4.31 ORIGATION REQUEST

4.31.1 MSC Initiating an Origination Request

When the MSC determines that the HLR must perform digit analysis (for other than a feature code), it shall perform the following:

- 1 Include the BillingID (Originating) parameter set to the billing identifier for the call assigned by the current Originating MSC.
- 2 Include the Digits (Dialed) parameter set to the digits received from the MS.
- 3 Include the ElectronicSerialNumber parameter set to identify the originating MS.
- 4 Include the MobileIdentificationNumber parameter set to identify the originating MS.
- 5 Include the MSCID parameter set to the identity of the Originating MSC.
- 6 Include the OriginationTriggers parameter set to identify the triggering event.
- 7 Include the TransactionCapability parameter set to identify the current capabilities.
- 8 Send a OriginationRequest INVOKE to the MS's associated HLR.
- 9 Start the Origination Request Timer (ORT).
- 10 WAIT for Origination Request response:
- 11 WHEN a RETURN RESULT is received:
 - 11-1 Stop timer (ORT).
 - 11-2 IF the message can be processed:
 - 11-2-1 IF the incoming call is still connected:
 - 11-2-1-1 IF the AnnouncementList parameter is received:
 - 11-2-1-1-1 Execute the "Play All Announcements in the AnnouncementList" task (see 3.2.5).
 - 11-2-1-2 ENDIF.
 - 11-2-1-3 IF the AccessDeniedReason parameter is received and it can be acted upon:
 - 11-2-1-3-1 IF AnnouncementList parameter is not received:
 - 11-2-1-3-1-1 Apply the treatment appropriate to the returned AccessDeniedReason value.
 - 11-2-1-3-1-2 Return to the calling task.
 - 11-2-1-3-2 ENDIF.
 - 11-2-1-4 ELSEIF no TerminationList parameter or ActionCode parameter is received (an error condition?):
 - 11-2-1-4-1 Execute the "Apply Access Denial Treatment" task (see 3.4.5).
 - 11-2-1-4-2 Return to the calling task.
 - 11-2-1-5 ENDIF.

11-2-1-6	IF the TerminationList parameter is received:	1
11-2-1-6-1	Execute the “MSC Routing Points Of Return” task (see 3.2.6).	2
11-2-1-7	ENDIF.	3
11-2-1-8	IF the ActionCode parameter is received:	4
11-2-1-8-1	Execute the “MSC ActionCode Processing” task (see 3.2.9).	5
11-2-1-9	ENDIF.	6
11-2-2	ENDIF.	7
11-3	ELSE (the message cannot be processed):	8
11-3-1	Execute “Local Recovery Procedures” task (see 3.5.1).	9
11-4	ENDIF.	10
12	WHEN a RemoteUserInteractionDirective INVOKE is received:	11
12-1	Stop timer (ORT).	12
12-2	Execute the “MSC Remote User Interaction” task (see 4.39.2).	13
12-3	Start the Origination Request Timer (ORT).	14
12-4	Remain in this state.	15
13	WHEN the MS disconnects:	16
13-1	Remain in this state (to handle possible call abandons).	17
14	WHEN a RETURN ERROR or REJECT is received:	18
14-1	Stop timer (ORT).	19
14-2	Execute “Local Recovery Procedures ” task (see 3.5.1).	20
14-3	Provide an unsuccessful indication to the MS.	21
15	WHEN timer (ORT) expires:	22
15-1	Execute “Local Recovery Procedures ” task (see 3.5.1).	23
15-2	Provide an unsuccessful indication to the MS.	24
16	ENDWAIT.	25
17	Return to the calling task.	26

4.31.2 HLR Receiving an OriginationRequest INVOKE

When an HLR receives a OriginationRequest INVOKE, it shall perform the following:

- 1 IF the received message can be processed:
 - 1-1 Execute the “HLR Analyze MS Dialed Number” task (see 3.2.4) to set the PointOfReturn.
 - 1-2 IF the PointOfReturn was not the *ToneTermination*
 - 1-2-1 Execute the “HLR SPINI Originating Call Invocation Task” (see 5.21.2).
 - 1-2-2 IF an AccessDeniedReason parameter is included:
 - 1-2-2-1 Send a RETURN RESULT.
 - 1-2-2-2 Exit this task.
 - 1-2-3 ENDIF.
 - 1-3 ENDIF.
 - 1-4 Relay the AnnouncementList parameter.

- 1
2
3
4
5
6
7
8
9
10
11
12
13
14
15
16
17
18
19
20
21
22
23
24
25
26
27
28
29
30
31
32
33
34
35
36
37
38
39
40
41
42
43
44
45
46
47
48
49
50
51
52
53
54
55
56
57
58
59
60
- 1-5 CASE PointOfReturn OF:
 - 1-6 *ToneTermination*:
 - 1-6-1 Include the *AccessDeniedReason* parameter set to the proper reason value (see the following table).
 - 1-6-2 Include the *MSCID* parameter set to the identity of the Originating MSC.
 - 1-7 *PSTNTermination*:
 - 1-7-1 GOTO OrReqMultTerm.
 - 1-8 *LocalTermination*:
 - 1-8-1 GOTO OrReqMultTerm.
 - 1-9 *IntersystemTermination*:
 - 1-9-1 GOTO OrReqMultTerm.
 - 1-10 *MultipleTermination*:
 - O T**
 - 1-10-2 IF at least one of the routes on the list is for a *LocalTermination*:
 - 1-10-2-1 Execute the “HLR CNIP Terminating Call Invocation” task (see 5.8.1).
 - 1-10-3 ENDIF.
 - 1-10-4 IF at least one of the routes on the list is for a *IntersystemTermination* or a *PSTNTermination*:
 - 1-10-4-1 Execute the “HLR CNIP Redirecting Call Invocation” task (see 5.8.2).
 - 1-10-5 ENDIF.
 - 1-10-6 FOR all desired routes in list:
 - 1-10-6-1 CASE type of route desired OF:
 - 1-10-6-2 *LocalTermination*:
 - 1-10-6-2-1 Include parameters for a local termination as determined by the feature.
 - 1-10-6-3 *IntersystemTermination*:
 - 1-10-6-3-1 Execute the “HLR Initiating a Routing Request” task (see 4.41.1) to set the PointOfReturn.
 - 1-10-6-3-2 Include parameters for an intersystem termination as determined by the feature.
 - 1-10-6-4 *PSTNTermination*
 - 1-10-6-4-1 Include parameters for a PSTN termination as determined by the feature.
 - 1-10-6-5 ENDCASE.
 - 1-10-6-6 Include termination in TerminationList.
 - 1-10-7 ENDFOR.
 - 1-11 *DEFAULT*:
 - 1-11-1 Send a RETURN ERROR with Error Code *SystemFailure*.
 - 1-11-2 Exit this task.
 - 1-12 ENDCASE.
 - 1-13 Send a RETURN RESULT to the requesting MSC.
 - 2 ELSE (the received message cannot be processed):

- 2-1 Send a RETURN ERROR with a proper Error Code value (see the following table) to the requesting MSC.
- 3 ENDIF.
- 4 Exit this task.

Table 41 HLR OriginationRequest Response

Problem Detection and Recommended Response from HLR to Originating MSC													
PROBLEM DEFINITION	1	2	3	4	5	6	7	8	9	10	11	12	Notes
RETURN ERROR Error Code													
<i>UnrecognizedMIN</i>											X		
<i>UnrecognizedESN</i>												X	
<i>MIN/HLRMismatch</i>							X						
<i>OperationSequenceProblem</i>													a
<i>ResourceShortage</i>		X											
<i>OperationNotSupported</i>	X												b
<i>TrunkUnavailable</i>													a
<i>ParameterError</i>				X									d
<i>SystemFailure</i>			X										d
<i>UnrecognizedParameterValue</i>					X								d
<i>FeatureInactive</i>													a
<i>MissingParameter</i>						X							d
RETURN RESULT AccessDeniedReason													c
<i>Unassigned directory number</i>								X					
<i>Inactive</i>									X				
<i>Busy</i>									X				
<i>Termination Denied</i>										X			
<i>No Page Response</i>									X				
<i>Unavailable</i>									X				

Problem Detections:

1. The requested MAP operation is recognized, but not supported, by the receiving HLR, or the requesting functional entity is not authorized.
2. A required HLR resource (e.g., internal memory record, HLR is fully occupied) is temporarily not available (e.g., congestion).
3. A required resource (e.g., data base access, functional entity) is not presently accessible due to a failure. Human intervention may be required for resolution.
4. A supplied parameter has an encoding problem (e.g., the Digits (Dialed) parameter has an inconsistent length, digits in the Digits (Dialed) parameter do not meet the BCD specification).
5. A supplied parameter value is unrecognized or has nonstandard values (e.g., *Not used*, the supplied Digits (Dialed) parameter contain an unexpected Code 11, Code 12, Spare, *, # or ST digit, the supplied Digits (Dialed) parameter is an unexpected length, the Digits (Dialed) parameter is using an unrecognized value for numbering plan, encoding, or type of digits).
6. An expected, or required, optional parameter (e.g., PC_SSN) was not received.
7. The supplied Digits (Dialed) parameter corresponds to a MobileDirectoryNumber that is not in the HLR's range of MINs or directory numbers (suspect routing error).
8. The supplied Digits (Dialed) parameter corresponds to a MobileDirectoryNumber that is within the range of the HLR, but the MobileDirectoryNumber is not presently assigned to an MS.

1
2
3
4
5
6
7
8
9
10
11
12
13
14
15
16
17
18
19
20
21
22
23
24
25
26
27
28
29
30
31
32
33
34
35
36
37
38
39
40
41
42
43
44
45
46
47
48
49
50
51
52
53
54
55
56
57
58
59
60

- 1
2
3
4
5
6
7
8
9
10
11
12
13
9. The supplied Digits (Dialed) parameter corresponds to an MS within the HLR, but the MS is either Inactive (powered down, failed to autonomously register, has call delivery deactivated), Busy, No Page Response or Unavailable and redirection (as Call Forwarding) does not apply.
 10. The supplied Digits (Dialed) parameter corresponds to an MS within the HLR, but the MS has a restriction of Termination denied or is AuthorizationDenied (e.g., *Delinquent Account*, *Stolen Unit*, *Duplicate Unit*, or *Unspecified*), the MIN has call origination deactivated and this request is not an origination activation request or the Digits (Dialed) parameter supplied exceed other OriginationIndicator restrictions.
 11. The HLR does not presently have a record for the supplied MobileIdentificationNumber parameter.
 12. The HLR presently has a record for the supplied MobileIdentificationNumber parameter, but the supplied ElectronicSerialNumber parameter does not match the ESN in that record.

14 Notes:

- 15
16
17
18
19
20
- a. This Error Code is not an appropriate HLR response to a OriginationRequest transaction.
 - b. It is recommended that an HLR supports OriginationRequest transactions.
 - c. Only RETURN RESULT operations needing clarification have been included.
 - d. Include the *Parameter Identifier* in question as the FaultyParameter parameter.

21
22
23
24

4.32 QUALIFICATION DIRECTIVE

25
26

4.32.1 HLR Initiating a Qualification Directive

27
28
29

When an HLR detects that an MS's profile or qualification information is changed, it shall perform the following:

- 30
31
32
33
34
35
36
37
38
39
40
41
42
43
44
45
46
47
48
49
50
51
52
53
54
55
56
57
58
59
60
- 1 IF the MS's current serving VLR is known:
 - 1-1 Include the ElectronicSerialNumber parameter set to the MS's ESN.
 - 1-2 Include the MobileIdentificationNumber parameter set to the MS's MIN.
 - 1-3 Include the SystemMyTypeCode parameter set to the HLR's manufacturer.
 - 1-4 IF the MS is not authorized:
 - 1-4-1 Include the AuthorizationDenied parameter.
 - 1-4-2 Include the DeniedAuthorizationPeriod parameter set appropriately.
 - 1-4-3 Set the QualificationInformationCode to *Validation only*.
 - 1-5 ELSEIF only profile is to be updated:
 - 1-5-1 Execute the "Loading of Profile Parameters" task (see 3.1.3).
 - 1-5-2 Set the QualificationInformationCode to *Profile only*.
 - 1-6 ELSEIF only validation parameters are to be updated:
 - 1-6-1 Include the AuthorizationPeriod parameter set appropriately.
 - 1-6-2 Set the QualificationInformationCode to *Validation only*.
 - 1-7 ELSEIF profile and validation parameters are to be updated:
 - 1-7-1 Execute the "Loading of Profile Parameters" task (see 3.1.3).
 - 1-7-2 Include the AuthorizationPeriod parameter set appropriately.
 - 1-7-3 Set the QualificationInformationCode to *Validation and profile*.
 - 1-8 ENDIF.
 - 1-9 Send a QualificationDirective INVOKE to the MS's current serving VLR.

- 1-10 Start the Qualification Directive Timer (QDT).
- 1-11 WAIT for a Qualification Directive response:
- 1-12 WHEN a RETURN RESULT is received:
 - 1-12-1 Stop timer (QDT).
 - 1-12-2 IF the message cannot be processed:
 - 1-12-2-1 Execute “Local Recovery Procedures” task (see 3.5.1).
 - 1-12-3 ENDIF.
- 1-13 WHEN a RETURN ERROR or REJECT is received:
 - 1-13-1 Stop timer (QDT).
 - 1-13-2 Execute “Local Recovery Procedures ” task (see 3.5.1).
- 1-14 WHEN timer (QDT) expires:
 - 1-14-1 Execute “Local Recovery Procedures ” task (see 3.5.1).
- 1-15 ENDWAIT.
- 2 ENDIF.
- 3 Exit this task.

4.32.2 VLR Receiving QualificationDirective INVOKE

When a VLR receives a QualificationDirective INVOKE, it shall perform the following:

- 1 IF the received message can be processed:
 - 1-1 IF AuthorizationDenied parameter is received:
 - 1-1-1 Clear the subscriber’s profile.
 - 1-1-2 The VLR may create a record in its internal data structures to indicate Authorization Denied for the indicated MS to prevent repetitive Registration Notification attempts.
 - 1-1-3 IF the DeniedAuthorizationPeriod parameter is received:
 - 1-1-3-1 Record the *denied authorization period* to prevent repetitive RegistrationNotification attempts.
 - 1-1-4 ELSE:
 - 1-1-4-1 Record the *denied authorization period* according to the results of internal algorithms to prevent repetitive RegistrationNotification attempts.
 - 1-1-5 ENDIF.
 - 1-2 ELSE:
 - 1-2-1 Update the subscriber’s service profile.
 - 1-3 ENDIF.
 - 1-4 Send a RETURN RESULT to the requesting HLR.
 - 1-5 Execute the “VLR Initiating a Qualification Directive” task (see 4.32.3).
- 2 ELSE (the received message cannot be processed):
 - 2-1 Send a RETURN ERROR with a proper Error Code value (see the following table) to the requesting HLR.
- 3 ENDIF.
- 4 Exit this task.

Table 42 VLR Qualification Directive Response

Problem Detection and Recommended Response from VLR to HLR									
PROBLEM DEFINITION	1	2	3	4	5	6	7	8	Notes
RETURN ERROR									
Error Code									
<i>UnrecognizedMIN</i>						X			
<i>UnrecognizedESN</i>							X		
<i>MIN/HLRMismatch</i>									a
<i>OperationSequenceProblem</i>									a
<i>ResourceShortage</i>		X							
<i>OperationNotSupported</i>	X								b
<i>TrunkUnavailable</i>									a
<i>ParameterError</i>				X					d
<i>SystemFailure</i>			X						
<i>UnrecognizedParameterValue</i>					X				d
<i>FeatureInactive</i>									a
<i>MissingParameter</i>								X	d
RETURN RESULT									c

Problem Detections:

- The requested MAP operation is recognized, but not supported, by the receiving VLR, or the requesting functional entity is not authorized.
- A required VLR resource (e.g., internal memory record, VLR is fully occupied) is temporarily not available (e.g., congestion).
- A required resource (e.g., data base access, functional entity) is not presently accessible due to a failure. Human intervention may be required for resolution.
- A supplied parameter has an encoding problem (e.g., the supplied MobileIdentificationNumber parameter digit values do not meet the BCD specification), a Digits parameter has an inconsistent length, digits in a Digits parameter do not meet the BCD specification, or two or more mutually exclusive optional parameters have been supplied (e.g., both AuthorizationDenied and AuthorizationPeriod).
- A supplied parameter value is unrecognized or has nonstandard values (e.g., *Not used*, a supplied Digits parameter does not have an expected number of digits, a Digits parameter contains a Code 11, a Code 12, or an ST digit, a Digits parameter is using an unrecognized value for numbering plan, encoding, or type of digit), the OriginationIndicator is set to *Prior agreement* and an agreement does not exist).
- A VLR record does not presently exist for the supplied MobileIdentificationNumber parameter.
- A VLR record exists for the supplied MobileIdentificationNumber parameter, but the supplied ElectronicSerialNumber parameter does not match the ESN in the VLR record.
- An expected, or required, optional parameter (e.g., AuthorizationDenied, AuthorizationPeriod, OriginationIndicator, TerminationRestrictionCode, CallingFeaturesIndicator, or a Digits (Carrier)) was not received. A received optional parameter required the VLR to expect an additional optional parameter that was not received (e.g., OriginationIndicator value set to *Selected NDC-X1 Xn*, but the expected Digits (Destination) parameter was not received).

Notes:

- This Error Code is not an appropriate VLR response to a QualificationDirective transaction.
- It is recommended that a VLR support the QualificationDirective transactions.
- Only RETURN RESULT operations needing clarification have been included.
- Include the *Parameter Identifier* in question as the FaultyParameter parameter.

4.32.3 VLR Initiating a Qualification Directive

When a VLR detects that an MS's profile or qualification information is changed, it shall perform the following:

- 1 Include the ElectronicSerialNumber parameter set to the MS's ESN.
- 2 Include the MobileIdentificationNumber parameter set to the MS's MIN.
- 3 Include the SystemMyTypeCode parameter set to the HLR's manufacturer.
- 4 IF the MS is not authorized:
 - 4-1 Include the AuthorizationDenied parameter.
 - 4-3 Include the QualificationInformationCode parameter set to *Validation only*.
- 5 ELSEIF only profile is to be updated:
 - 5-1 Execute the "Loading of Profile Parameters" task (see 3.1.3).
 - 5-2 Include the QualificationInformationCode parameter set to *Profile only*.
- 6 ELSEIF only validation parameters are to be updated:
 - 6-1 Include the AuthorizationPeriod parameter set appropriately.
 - 6-2 Include the QualificationInformationCode parameter set to *Validation only*.
- 7 ELSEIF profile and validation parameters are to be updated:
 - 7-1 Execute the "Loading of Profile Parameters" task (see 3.1.3).
 - 7-2 Include the AuthorizationPeriod parameter set appropriately.
 - 7-3 Include the QualificationInformationCode parameter set to *Validation and profile*.
- 8 ENDIF.
- 9 Start the Qualification Directive Timer (QDT).
- 10 Send a QualificationDirective INVOKE to the MS's current Serving MSC.
- 11 WAIT for a Qualification Directive response:
- 12 WHEN a RETURN RESULT is received:
 - 12-1 Stop timer (QDT).
 - 12-2 IF the message cannot be processed:
 - 12-2-1 Execute "Local Recovery Procedures" task (see 3.5.1).
 - 12-3 ENDIF.
- 13 WHEN a RETURN ERROR or REJECT is received:
 - 13-1 Stop timer (QDT).
 - 13-2 Execute "Local Recovery Procedures " task (see 3.5.1).
- 14 WHEN timer (QDT) expires:
 - 14-1 Execute "Local Recovery Procedures " task (see 3.5.1).
- 15 ENDWAIT.
- 16 Return to the calling task.

4.32.4 MSC Receiving QualificationDirective INVOKE

When an MSC receives a QualificationDirective INVOKE:

- 1 IF the received message can be processed:

1
2
3
4
5
6
7
8
9
10
11
12
13
14
15
16
17
18
19
20
21
22
23
24
25
26
27
28
29
30
31
32
33
34
35
36
37
38
39
40
41
42
43
44
45
46
47
48
49
50
51
52
53
54
55
56
57
58
59
60

- 1-1 IF AuthorizationDenied parameter is received:
 - 1-1-1 IF the indicated MS is involved in a call or service operation anchored by this MSC:
 - 1-1-1-1 The MSC may optionally discontinue the call or service operation currently in progress.
 - 1-1-2 ENDIF.
 - 1-1-3 Clear the subscriber's profile.
 - 1-2 ELSEIF the indicated MS's profile information is received:
 - 1-2-1 Overwrite any existing profile parameter(s) with the received value(s).
 - 1-2-2 Add any new profile parameter(s) received to the MS's profile information.
 - 1-2-3 Execute the "MSC MWN Status Change Invocation" task (see 5.13.9).
 - 1-3 ENDIF.
 - 1-4 Send a RETURN RESULT to the requesting VLR.
 - 1-5 IF the indicated MS is involved in a call or service operation anchored by this MSC:
 - 1-5-1 IF the MS is not authorized for the current call or service operation:
 - 1-5-1-1 The Serving System may optionally discontinue the call or service operation currently in progress.
 - 1-5-2 ENDIF.
 - 1-6 ENDIF.
- 2 ELSE (the received message cannot be processed):
 - 2-1 Send a RETURN ERROR with a proper value (see the following table) to the requesting VLR.
 - 3 ENDIF.
 - 4 Exit this task.

Table 43 MSC Qualification Directive Response

Problem Detection and Recommended Response from MSC to VLR									
PROBLEM DEFINITION	1	2	3	4	5	6	7	8	Notes
RETURN ERROR									
Error Code									
<i>UnrecognizedMIN</i>						X			
<i>UnrecognizedESN</i>							X		
<i>MIN/HLRMismatch</i>									a
<i>OperationSequenceProblem</i>									a
<i>ResourceShortage</i>		X							
<i>OperationNotSupported</i>	X								b
<i>TrunkUnavailable</i>									a
<i>ParameterError</i>				X					d
<i>SystemFailure</i>			X						
<i>UnrecognizedParameterValue</i>					X				d
<i>FeatureInactive</i>									a
<i>MissingParameter</i>								X	d
RETURN RESULT									c

Problem Detections:

1. The requested MAP operation is recognized, but not supported, by the receiving MSC, or the requesting functional entity is not authorized.
2. A required MSC resource (e.g., internal memory record, MSC is fully occupied) is temporarily not available (e.g., congestion).
3. A required resource (e.g., data base access, functional entity) is not presently accessible due to a failure. Human intervention may be required for resolution.
4. A supplied parameter has an encoding problem (e.g., the supplied MobileIdentificationNumber parameter digit values do not meet the BCD specification), a Digits parameter has an inconsistent length, digits in a Digits parameter do not meet the BCD specification, or two or more mutually exclusive optional parameters have been supplied (e.g., both AuthorizationDenied and AuthorizationPeriod).
5. A supplied parameter value is unrecognized or has nonstandard values (e.g., *Not used*, a supplied Digits parameter does not have an expected number of digits, a Digits parameter contains a Code 11, a Code 12, or an ST digit, a Digits parameter is using an unrecognized value for numbering plan, encoding, or type of digit), the OriginationIndicator is set to *Prior agreement* and an agreement does not exist).
6. An MSC record does not presently exist for the supplied MobileIdentificationNumber parameter.
7. An MSC record exists for the supplied MobileIdentificationNumber parameter, but the supplied ElectronicSerialNumber parameter does not match the ESN in the MSC record.
8. An expected, or required, optional parameter (e.g., AuthorizationDenied, AuthorizationPeriod, OriginationIndicator, TerminationRestrictionCode, CallingFeaturesIndicator, Digits (Carrier)) was not received. A received optional parameter required the MSC to expect an additional optional parameter that was not received (e.g., OriginationIndicator value set to *Selected NDC-XI Xn* but the expected Digits (Destination) parameter was not received).

Notes:

- a. This Error Code is not an appropriate MSC response to a QualificationDirective transaction.
- b. It is recommended that an MSC supports QualificationDirective transactions.
- c. Only RETURN RESULT operations needing clarification have been included.
- d. Include the *Parameter Identifier* in question as the FaultyParameter parameter.

4.33 QUALIFICATION REQUEST

The Qualification Request Task is executed to retrieve the MS's qualification information or profile information or both. The HLR does not update the MS's current location pointer when the Qualification Request Task is executed.

4.33.1 MSC Initiating a Qualification Request

When an MSC determines that it needs to retrieve an MS's qualification information, profile information, or both; it shall perform the following:

- 1 Include the MSCID parameter set to the identity of the requesting MSC.
- 2 Include the SenderIdentificationNumber parameter of the sending functional entity.
- 3 Include the SystemAccessType parameter set to the type of access triggering the request.
- 4 Include the TransactionCapability parameter set to the current capabilities of the system.
- 5 Include the MobileIdentificationNumber parameter set to identify the requesting MS.
- 6 Include the ElectronicSerialNumber parameter set to identify the requesting MS.
- 7 Include the QualificationInformationCode parameter set to indicate the required qualification information, profile information, or both.
- 8 Include the SystemMyTypeCode parameter set to indicate the manufacturer of the MSC.
- 9 Send a QualificationRequest INVOKE to its associated VLR.
- 10 Start the Qualification Request Timer (QRT).
- 11 WAIT for a Qualification Request response:
- 12 WHEN a RETURN RESULT is received:
 - 12-1 Stop timer (QRT).
 - 12-2 IF the message can be processed:
 - 12-2-1 IF an AuthorizationDenied parameter is received:
 - 12-2-1-1 IF the indicated MS is involved in a call or service operation anchored by this MSC:
 - 12-2-1-1-1 The Serving MSC may optionally discontinue the call or service operation currently in progress.
 - 12-2-1-2 ENDIF.
 - 12-2-1-3 Clear the subscriber's profile.
 - 12-2-2 ELSEIF profile information for the indicated MS is received:
 - 12-2-2-1 Overwrite any existing profile parameter(s) with the received value(s).
 - 12-2-2-2 Add any new profile parameter(s) received to the MS's profile information.
 - 12-2-2-3 Execute the "MSC MWN Status Change Invocation" task (see 5.13.9).
 - 12-2-3 ENDIF.
 - 12-3 ELSE (the message cannot be processed):

12-3-1	Execute “Local Recovery Procedures” task (see 3.5.1).	1
12-4	ENDIF.	2
13	WHEN a RETURN ERROR or REJECT is received:	3
13-1	Stop timer (QRT).	4
13-2	Execute “Local Recovery Procedures ” task (see 3.5.1).	5
14	WHEN timer (QRT) expires:	6
14-1	Execute “Local Recovery Procedures ” task (see 3.5.1).	7
15	ENDWAIT.	8
16	IF the indicated MS is involved in a call or service operation anchored by this MSC:	9
16-1	IF the service profile information does not authorize the current call or service operation:	10
16-1-1	The Serving System may optionally discontinue the call or service operation currently in progress.	11
16-2	ENDIF.	12
17	ENDIF.	13
18	Exit this task.	14
		15
		16
		17
		18
		19
		20
		21
		22
		23
		24
		25
		26
		27
		28
		29
		30
		31
		32
		33
		34
		35
		36
		37
		38
		39
		40
		41
		42
		43
		44
		45
		46
		47
		48
		49
		50
		51
		52
		53
		54
		55
		56
		57
		58
		59
		60

4.33.2 VLR Initiating a Qualification Request

When a VLR determines that it needs to retrieve an MS’s qualification information, profile information, or both; it shall perform the following:

- 1 Include the MSCID parameter set to the identity of the Serving MSC.
- 2 Include the SenderIdentificationNumber parameter of the sending functional entity.
- 3 Include the SystemAccessType parameter set to the type of access triggering the request.
- 4 Include the TransactionCapability parameter set to the current capabilities of the VLR.
- 5 Send a QualificationRequest INVOKE to the MS’s HLR.
- 6 Start the Qualification Request Timer (QRT).
- 7 WAIT for a Qualification Request response:
- 8 WHEN a RETURN RESULT is received:
 - 8-1 Stop timer (QRT).
 - 8-2 IF the message can be processed:
 - 8-2-1 IF AuthorizationDenied parameter is received:
 - 8-2-1-1 Clear the subscriber’s profile.
 - 8-2-1-2 The VLR may create a record in its internal data structures to indicate Authorization Denied for the indicated MS to prevent repetitive Registration Notification attempts.
 - 8-2-1-3 IF the DeniedAuthorizationPeriod parameter is received:
 - 8-2-1-3-1 Record the *denied authorization period* to prevent repetitive RegistrationNotification attempts.
 - 8-2-1-4 ELSE:

- 1 8-2-1-4-1 Record the *denied authorization period* according to the results of
2 internal algorithms to prevent repetitive RegistrationNotification
3 attempts.
4
5 8-2-1-5 ENDIF.
6 8-2-2 ELSEIF profile information for the indicated MS is received:
7 8-2-2-1 Overwrite any existing profile parameter(s) with the received value(s).
8 8-2-2-2 Add any new profile parameter(s) received to the MS's profile
9 information.
10
11 8-2-3 ENDIF.
12
13 8-2-4 Execute the "VLR Initiating a Qualification Directive" task to update the MSC
14 (see 4.32.3).
15
16 8-3 ELSE:
17 8-3-1 Execute "Local Recovery Procedures" task (see 3.5.1).
18 8-4 ENDIF.
19
20 9 WHEN a RETURN ERROR or REJECT is received:
21 9-1 Stop timer (QRT).
22 9-2 Execute "Local Recovery Procedures " task (see 3.5.1).
23
24 10 WHEN timer (QRT) expires:
25 10-1 Execute "Local Recovery Procedures " task (see 3.5.1).
26
27 11 ENDIF.
28 12 Exit this task.

4.33.3 VLR Receiving QualificationRequest INVOKE

When a VLR receives a QualificationRequest INVOKE, it shall perform the following:

- 1 IF the received message can be processed:
2 1-1 IF the indicated MS is known to the VLR AND the requested information can be
3 made available for the indicated MS:
4 1-1-1 IF the MS is not allowed to register (e.g., the MS is on a negative list or
5 registration attempts for the MS from same MSCID and LocationAreaID
6 have failed in the recent past or the request is within a previously received
7 DeniedAuthorizationPeriod):
8 1-1-1-1 Include the AuthorizationDenied parameter.
9 1-1-2 ELSE (the MS is allowed to register and is authorized for service):
10 1-1-2-1 IF the received QualificationInformationCode parameter is *Profile only*
11 or *Validation and profile*:
12 1-1-2-1-1 Execute the "Loading of Profile Parameters" task (see 3.1.3).
13 1-1-2-2 ENDIF.
14 1-1-2-3 IF the received QualificationInformationCode parameter is *Validation*
15 only or *Validation and profile*:
16 1-1-2-3-1 Include the AuthorizationPeriod parameter set appropriately.
17 1-1-2-4 ENDIF.
18 1-1-3 ENDIF.
19 1-1-4 Send a RETURN RESULT to the requesting MSC.

1-2	ELSE (the indicated MS is not known to the VLR OR the requested information cannot be made available for the indicated MS):	1
		2
		3
1-2-1	Include the SenderIdentificationNumber parameter of the sending functional entity.	4
		5
1-2-2	Relay the other received parameters.	6
		7
1-2-3	Send a QualificationRequest INVOKE to the MS's HLR.	8
		9
1-2-4	Start the Qualification Request Timer (QRT).	10
		11
1-2-5	WAIT for a Qualification Request response:	12
1-2-6	WHEN a RETURN RESULT is received:	13
1-2-6-1	Stop timer (QRT).	14
		15
1-2-6-2	IF the message can be processed:	16
1-2-6-2-1	IF AuthorizationDenied parameter is received:	17
1-2-6-2-1-1	Clear the subscriber's profile.	18
1-2-6-2-1-2	The VLR may create a record in its internal data structures to indicate Authorization Denied for the indicated MS to prevent repetitive Registration Notification attempts.	19
		20
		21
1-2-6-2-1-3	IF the DeniedAuthorizationPeriod parameter is received:	22
1-2-6-2-1-3-1	Record the <i>denied authorization period</i> to prevent repetitive RegistrationNotification attempts.	23
		24
		25
1-2-6-2-1-4	ELSE:	26
1-2-6-2-1-4-1	Record the <i>denied authorization period</i> according to the results of internal algorithms to prevent repetitive RegistrationNotification attempts.	27
		28
		29
		30
1-2-6-2-1-5	ENDIF.	31
		32
1-2-6-2-2	ELSE:	33
1-2-6-2-2-1	Update the subscriber's service profile and authorization.	34
		35
1-2-6-2-3	ENDIF.	36
		37
1-2-6-2-4	Relay the received parameters.	38
		39
1-2-6-2-5	Send a RETURN RESULT to the requesting MSC.	40
		41
1-2-6-3	ELSE:	42
1-2-6-3-1	Send a RETURN ERROR with Error Code <i>SystemFailure</i> to the requesting MSC.	43
		44
1-2-6-3-2	Execute "Local Recovery Procedures" task (see 3.5.1).	45
		46
1-2-6-4	ENDIF.	47
		48
1-2-7	WHEN a RETURN ERROR or REJECT is received:	49
1-2-7-1	Stop timer (QRT).	50
		51
1-2-7-2	Execute "Local Recovery Procedures" task (see 3.5.1).	52
		53
1-2-7-3	CASE Error Code OF:	54
		55
1-2-7-4	<i>ParameterError</i> :	56
1-2-7-4-1	IF the parameter was originated from the initiating functional entity:	57
1-2-7-4-1-1	Send a RETURN ERROR with Error Code <i>ParameterError</i> .	58
		59
1-2-7-4-2	ELSE:	60
1-2-7-4-2-1	Send a RETURN ERROR with Error Code <i>SystemFailure</i> .	

1 1-2-7-4-3 ENDIF.

2

3 1-2-7-5 *OperationSequenceProblem:*

4 1-2-7-5-1 Send a RETURN ERROR with Error Code

5 *OperationSequenceProblem.*

6

7 1-2-7-6 *DEFAULT:*

8 1-2-7-6-1 Send a RETURN ERROR with Error Code *SystemFailure.*

9

10 1-2-7-7 ENDCASE.

11 1-2-8 WHEN timer (QRT) expires:

12 1-2-8-1 Send a RETURN ERROR with Error Code *SystemFailure* to the

13 requesting MSC.

14 1-2-8-2 Execute “Local Recovery Procedures ” task (see 3.5.1).

15

16 1-2-9 ENDWAIT.

17 1-3 ENDIF.

18 2 ELSE (the received message cannot be processed):

19

20 2-1 Send a RETURN ERROR with a proper value (see the following table) to the

21 requesting MSC.

22

23 3 ENDIF.

24 4 Exit this task.

25

26

27

28

29

30

31

32

33

34

35

36

37

38

39

40

41

42

43

44

45

46

47

48

49

50

51

52

53

54

55

56

57

58

59

60

Table 44 VLR QualificationRequest Response

Problem Detection and Recommended Response from VLR to MSC											
PROBLEM DEFINITION	1	2	3	4	5	6	7	8	9	10	Notes
RETURN ERROR											
Error Code											
<i>UnrecognizedMIN</i>											a
<i>UnrecognizedESN</i>											a
<i>MIN/HLRMismatch</i>						X					e
<i>OperationSequenceProblem</i>											a
<i>ResourceShortage</i>		X									e
<i>OperationNotSupported</i>	X										b, e
<i>TrunkUnavailable</i>											a
<i>ParameterError</i>				X							d
<i>SystemFailure</i>			X								e
<i>UnrecognizedParameterValue</i>					X						d, e
<i>FeatureInactive</i>											a
<i>MissingParameter</i>							X				d
RETURN RESULT											c
<i>AuthorizationDenied</i>											
<i>Delinquent Account</i>										X	e
<i>Invalid Serial Number</i>									X		e
<i>Stolen Unit</i>										X	e
<i>Duplicate Unit</i>										X	e
<i>Unassigned Directory Number</i>								X			e
<i>Unspecified</i>										X	e
<i>Multiple access</i>										X	e
<i>Not Authorized for the MSC</i>										X	e
<i>Missing authentication parameters</i>										X	e
<i>TerminalType mismatch</i>										X	e

Problem Detections:

- The requested MAP operation is recognized, but not supported, by the receiving VLR, or the requesting functional entity is not authorized.
- A required VLR resource (e.g., internal memory record, VLR is fully occupied) is temporarily not available (e.g., congestion).
- A required resource (e.g., data base access, functional entity) is not presently accessible due to a failure. Human intervention may be required for resolution.
- A supplied parameter has an encoding problem (e.g., the supplied MobileIdentificationNumber parameter digit values do not meet the BCD specification).
- A supplied parameter value is unrecognized or has nonstandard values (e.g., *Not used*).
- The supplied MIN's HLR responded that the MobileIdentificationNumber parameter is not in the HLR's range of MIN's or directory numbers (suspect routing error).
- An expected, or required, optional parameter (e.g., AuthorizationDenied, AuthorizationPeriod, OriginationIndicator, TerminationRestrictionCode, CallingFeaturesIndicator, or a Digits (Carrier)) was not received. A received optional parameter required the VLR to expect an additional optional parameter that was not received (e.g., OriginationIndicator value set to *Selected NDC-XI Xn*, but the expected Digits (Destination) parameter was not received).
- The supplied MobileIdentificationNumber parameter's HLR responded that the MIN is within the range of the HLR, but the MIN is not presently assigned to a subscriber.
- A VLR record exists for the supplied MobileIdentificationNumber parameter, but the supplied ElectronicSerialNumber parameter does not match the ESN in the MIN's record.

10. A VLR record exists for the supplied MobileIdentificationNumber parameter, but the MIN is either a *Delinquent Account*, *Stolen Unit*, *Duplicate Unit*, *Unspecified*, *Multiple access*, *NotAuthorized for the MSC*, *Missing authentication parameters*, or *TerminalType mismatch* .

Notes:

- a. This Error Code is not an appropriate VLR response to a QualificationRequest transaction.
- b. It is recommended that a VLR support the QualificationRequest transactions.
- c. Only RETURN RESULT operations needing clarification have been included.
- d. Include the *Parameter Identifier* in question as the FaultyParameter parameter.
- e. This response may have been originated by the HLR.

4.33.4 HLR Receiving QualificationRequest INVOKE

When an HLR receives a QualificationRequest INVOKE, it shall perform the following:

- 1 IF the received message can be processed:
 - 1-1 IF the MS is authorized for the service:
 - 1-1-1 IF the received QualificationInformationCode parameter is *Profile only* or *Validation and profile*:
 - 1-1-1-1 Execute the "Loading of Profile Parameters" task (see 3.1.3).
 - 1-1-1-2 ENDIF.
 - 1-1-1-3 IF the received QualificationInformationCode parameter is *Validation only* or *Validation and profile*:
 - 1-1-1-3-1 Include the AuthorizationPeriod parameter set appropriately.
 - 1-1-1-3-2 ENDIF.
 - 1-1-1-4 ELSE:
 - 1-1-1-4-1 Include the AuthorizationDenied parameter set appropriately.
 - 1-1-1-4-2 Include the DeniedAuthorizationPeriod parameter set appropriately.
 - 1-1-1-5 ENDIF.
 - 1-1-1-6 Send a RETURN RESULT to the requesting VLR.
 - 1-1-2 ELSE (the received message cannot be processed or the requested information cannot be made available for the indicated MS):
 - 1-1-2-1 Send a RETURN ERROR with a proper Error Code value (see the following table) to the requesting VLR.
 - 1-1-3 ENDIF.
 - 1-1-4 Exit this task.

Table 45 HLR Qualification Request Response

Problem Detection and Recommended Response from HLR to VLR											
PROBLEM DEFINITION	1	2	3	4	5	6	7	8	9	10	Notes
RETURN ERROR											
Error Code											
<i>UnrecognizedMIN</i>											a
<i>UnrecognizedESN</i>											a
<i>MIN/HLRMismatch</i>						X					
<i>OperationSequenceProblem</i>											a
<i>ResourceShortage</i>		X									
<i>OperationNotSupported</i>	X										b
<i>TrunkUnavailable</i>											a
<i>ParameterError</i>				X							d
<i>SystemFailure</i>			X								
<i>UnrecognizedParameterValue</i>					X						d
<i>FeatureInactive</i>											a
<i>MissingParameter</i>							X				d
RETURN RESULT											c
<i>AuthorizationDenied</i>											
<i>Delinquent Account</i>										X	
<i>Invalid Serial Number</i>									X		
<i>Stolen Unit</i>										X	
<i>Duplicate Unit</i>										X	
<i>Unassigned Directory Number</i>								X			
<i>Unspecified</i>										X	
<i>Multiple access</i>										X	
<i>Not Authorized for the MSC</i>										X	
<i>Missing authentication parameters</i>										X	
<i>TerminalType mismatch</i>										X	

Problem Detections:

1. The requested MAP operation is recognized, but not supported, by the receiving HLR, or the requesting functional entity is not authorized.
2. A required HLR resource (e.g., internal memory record, HLR is fully occupied) is temporarily not available (e.g., congestion).
3. A required resource (e.g., data base access, functional entity) is not presently accessible due to a failure. Human intervention may be required for resolution.
4. A supplied parameter has an encoding problem (e.g., the supplied MobileIdentificationNumber parameter digit values do not meet the BCD specification).
5. A supplied parameter value is unrecognized or has nonstandard values (e.g., *Not used*).
6. The supplied MobileIdentificationNumber parameter is not in the HLR's range of MINs or directory numbers (suspect routing error).
7. An expected, or required, optional parameter (e.g., AuthorizationDenied, AuthorizationPeriod, OriginationIndicator, TerminationRestrictionCode, CallingFeaturesIndicator, or a Digits (Carrier)) was not received. A received optional parameter required the VLR to expect an additional optional parameter that was not received (e.g., OriginationIndicator value set to *Selected NDC-XI Xn*, but the expected Digits (Destination) parameter was not received).
8. The supplied MobileIdentificationNumber parameter is within the range of the HLR, but the MIN is not presently assigned to a subscriber.
9. The supplied MobileIdentificationNumber parameter is within the range of the HLR, but the supplied ElectronicSerialNumber parameter is not valid for the MIN's record.

10. The supplied `MobileIdentificationNumber` parameter is within the range of the HLR, but the MIN is either a *Delinquent Account*, *Stolen Unit*, *Duplicate Unit*, *Unspecified*, *Multiple access*, *NotAuthorized for the MSC*, *Missing authentication parameters*, or *TerminalType mismatch*.

Notes:

- a. This Error Code is not an appropriate HLR response to a `QualificationRequest` transaction.
- b. It is recommended that an HLR supports `QualificationRequest` transactions.
- c. Only RETURN RESULT operations needing clarification have been included.
- d. Include the *Parameter Identifier* in question as the `FaultyParameter` parameter.

4.34 RANDOM VARIABLE REQUEST

If an MSC determines that a roaming mobile station accessing this system has used a `RandomVariable (RAND)` value that may have been transmitted by a cell site in a neighboring MSC, the Serving MSC shall start the random variable request process.

4.34.1 MSC Initiating a Random Variable Request

If an MSC receives an invalid `RANDC` from an MS, and determines that the `RANDC` value may be associated with a `RandomVariable (RAND)` currently transmitted by a cell site in a neighboring MSC, the MSC shall perform the following:

- 1 IF the `RANDC` received from the MS is equal to the most significant eight bits of a valid `RandomVariable (RAND)` value stored for the neighboring MSC:
 - 1-1 Return to the invoking process with the valid value of `RandomVariable (RAND)` parameter received from the neighboring MSC.
- 2 ENDIF.
- 3 Include the `ServingCellID` parameter set to the ID of the cell where the MS access was received.
- 4 Include the `RANDC` parameter set to the `RANDC` value received from the MS.
- 5 Include `MSCID` parameter set to the identity of this MSC.
- 6 Send a `RandomVariableRequest INVOKE` to the neighboring MSC.
- 7 Start the `Random Variable Request Timer (RANDRT)`.
- 8 WAIT for a random variable request response.
- 9 WHEN a RETURN RESULT is received:
 - 9-1 Stop timer (`RANDRT`).
 - 9-2 IF the message can be processed:
 - 9-2-1 IF the `RandomVariable (RAND)` parameter is present:
 - 9-2-1-1 Store the received `RandomVariable (RAND)` and mark it valid for the period indicated by the `RANDValidTime` parameter.
 - 9-2-1-2 Return to the invoking process with the received value of `RAND`.
 - 9-2-2 ELSE (`RandomVariable (RAND)` parameter not received from neighboring MSC):
 - 9-2-2-1 Return to the invoking process with an indication of *unsuccessful*.
 - 9-2-3 ENDIF.
 - 9-3 ELSE (the message cannot be processed):

- 9-3-1 Execute the “Local Recovery Procedures” task (see 3.5.1).
- 9-3-2 Return to the invoking process with an indication of *unsuccessful*.
- 9-4 ENDIF.
- 10 WHEN a RETURN ERROR or REJECT is received:
 - 10-1 Stop timer (RANDRT).
 - 10-2 Execute the “Local Recovery Procedures ” task (see 3.5.1).
 - 10-3 Return to the invoking process with an indication of *unsuccessful*.
- 11 WHEN the timer (RANDRT) expires:
 - 11-1 Execute the “Local Recovery Procedures ” task (see 3.5.1).
 - 11-2 Return to the invoking process with an indication of *unsuccessful*.
- 12 ENDWAIT.

4.34.2 MSC Receiving RandomVariableRequest INVOKE

If an MSC receives a RandomVariableRequest INVOKE message, it shall perform the following:

- 1 IF the received message can be processed:
 - 1-1 IF the received RANDC value is valid (See Annex A, “Procedures for RANDC Verification”):
 - 1-1-1 Include the RandomVariable (RAND) parameter.
 - 1-1-2 Set the RANDValidTime parameter set to the period for which the RANDC value will remain associated with the identified RAND.
 - 1-1-3 Include the RANDValidTime parameter.
 - 1-1-4 Send a RETURN RESULT to the requesting MSC.
 - 1-1-5 Exit this task.
 - 1-2 ELSE (RANDC is not valid):
 - 1-2-1 Send an empty RETURN RESULT to the requesting MSC.
 - 1-2-2 Exit this task.
 - 1-3 ENDIF.
- 2 ELSE (the received message cannot be processed):
 - 2-1 Send a RETURN ERROR with the proper Error Code value (see the following table) to the requesting MSC.
 - 2-2 Exit this task.
- 3 ENDIF.

Table 46 MSC RandomVariableRequest (RANDREQ) Response

Problem Detection and Recommended Response from Neighboring MSC to Serving MSC					
PROBLEM DEFINITION	1	2	3	4	Notes
RETURN ERROR Error Code					
<i>UnrecognizedMIN</i>					a
<i>UnrecognizedESN</i>					a
<i>MIN/HLRMismatch</i>					a
<i>OperationSequenceProblem</i>					a
<i>ResourceShortage</i>		X			
<i>OperationNotSupported</i>	X				b
<i>TrunkUnavailable</i>					a
<i>ParameterError</i>					a
<i>SystemFailure</i>			X		
<i>UnrecognizedParameterValue</i>				X	d
<i>FeatureInactive</i>					a
<i>MissingParameter</i>					a
RETURN RESULT					c

Problem Detections:

1. The requested MAP operation is recognized, but not supported by the receiving MSC or the requesting functional entity is not authorized.
2. A required MSC resource is temporarily not available.
3. A required resource (e.g., data base access, functional entity) is not presently accessible due to a failure. Human intervention may be required for resolution.
4. A supplied parameter value is unrecognized or has nonstandard values.

Notes:

- a. This Error Code is not an appropriate response to a RandomVariableRequest INVOKE.
- b. It is recommended that an MSC supports RandomVariableRequest transactions.
- c. Only the RETURN RESULT operations needing clarification have been included.
- d. Include the *Parameter Identifier* in question as the FaultyParameter parameter.

4.35 REDIRECTION DIRECTIVE**4.35.1 MSC Initiating a Redirection Directive**

When an adjunct MSC determines that the Originating MSC shall redirect the call to a destination directory number, it shall perform the following:

- 1 Include the Digits (Destination) parameter set to the call forwarding number.
- 2 IF applicable:
 - 2-1 Include the Digits (Carrier) parameter.
- 3 ENDIF.
- 4 IF applicable:
 - 4-1 Include the RedirectingNumberString and RedirectingSubaddress parameters.
- 5 ENDIF.

- 6 IF applicable: 1
- 6-1 Include the DMH_AccountCodeDigits, DMH_AlternateBillingDigits and 2
DMH_BillingDigits parameters. 3
- 7 ENDIF. 4
- 8 Include the MSCIdentificationNumber, parameter set to the MSC's identification 5
number. 6
- 9 Send a RedirectionDirective INVOKE to the Originating MSC associated with this 7
call. 8
- 10 Start the Redirection Directive Timer (RDT). 9
- 11 WAIT for a Redirection Directive response: 10
- 12 WHEN a RETURN RESULT is received: 11
- 12-1 Stop timer (RDT). 12
- 12-2 IF the message can be processed: 13
- 12-2-1 IF the call is still connected: 14
- 12-2-1-1 Execute the call release procedures. 15
- 12-2-1-2 Exit this task. 16
- 12-2-2 ELSE (call is no longer connected): 17
- 12-2-2-1 Exit this task. 18
- 12-3 ELSE (the message cannot be processed): 19
- 12-3-1 Execute the "Local Recovery Procedures" task (see 3.5.1). 20
- 12-3-2 Exit this task. 21
- 12-4 ENDIF. 22
- 13 WHEN the call disconnects: 23
- 13-1 Stop timer (RDT). 24
- 13-2 Execute the call release procedures. 25
- 13-3 Exit this task. 26
- 14 WHEN a RETURN ERROR or REJECT is received: 27
- 14-1 Stop timer (RDT). 28
- 14-2 Execute the "Local Recovery Procedures " task (see 3.5.1). 29
- 14-3 Exit this task. 30
- 15 WHEN timer (RDT) expires: 31
- 15-1 Execute the "Local Recovery Procedures " task (see 3.5.1). 32
- 15-2 Exit this task. 33
- 16 ENDWAIT. 34

4.35.2 MSC Receiving RedirectionDirective INVOKE 35

When an MSC receives a RedirectionDirective INVOKE, it shall perform the following: 36

- 1 IF the received message can be processed: 37
- 1-1 IF there is a call or leg in progress that is associated with the received BillingID 38
and the MobileIdentificationNumber parameters: 39
- 1-1-1 Release the associated facilities toward the requesting MSC. 40

- 1 1-1-2 Send a RETURN RESULT to the requesting MSC.
 2 1-1-3 Redirect the call to the received destination address.
 3 1-1-4 IF applicable:
 4 1-1-4-1 Maintain the transmission of answer supervision on the incoming facility,
 5 if applicable.
 6 1-1-5 ENDIF.
 7 1-1-6 Exit this task.
 8 1-2 ELSE (there is no call or leg in process):
 9 1-2-1 Send a RETURN ERROR with a proper Error Code value (see the following
 10 table) to the requesting MSC.
 11 1-2-2 Exit this task.
 12 1-3 ENDIF.
 13 2 ELSE (the received message cannot be processed):
 14 2-1 Execute "Local Recovery Procedures" task (see 3.5.1).
 15 2-2 Send a RETURN ERROR with a proper Error Code value (see the following
 16 table) to the requesting MSC.
 17 3 ENDIF.
 18 4 Exit this task.

Table 47 Originating MSC RedirectionDirective Response

Problem Detection and Recommended Response from Originating MSC to Adjunct MSC								
PROBLEM DEFINITION	1	2	3	4	5	6	7	Notes
RETURN ERROR								
Error Code								
<i>UnrecognizedMIN</i>						X		
<i>UnrecognizedESN</i>							X	
<i>MIN/HLRMismatch</i>								a
<i>OperationSequenceProblem</i>								a
<i>ResourceShortage</i>		X						
<i>OperationNotSupported</i>	X							b
<i>TrunkUnavailable</i>								a
<i>ParameterError</i>				X				d
<i>SystemFailure</i>			X					
<i>UnrecognizedParameterValue</i>					X			d
<i>FeatureInactive</i>								a
<i>MissingParameter</i>								a
RETURN RESULT								c

Problem Detections:

- 1 The requested MAP operation is recognized, but not supported, by the receiving Originating MSC, or the requesting functional entity is not authorized.
- 2 A required Originating MSC resource (e.g., internal memory record, MSC is fully occupied) is temporarily not available (e.g., congestion).
- 3 A required resource (e.g., data base access, functional entity) is not presently accessible due to a failure or the Digits (Destination) parameter received from the HLR is not acceptable. Human intervention may be required for resolution.

- 4 A supplied parameter value has an encoding problem (e.g., The supplied MobileIdentificationNumber parameter digit values do not meet the BCD specification). 1
2
- 5 A supplied parameter value is unrecognized or has nonstandard values (e.g., *Not used*, the Originating MSC does not presently have a routed call attempt active for the supplied BillingID parameter). 3
4
5
6
- 6 The Originating MSC does not presently have a routed call attempt active for the supplied MobileIdentificationNumber parameter. 7
8
- 7 The Originating MSC has a routed call attempt active for the supplied MobileIdentificationNumber parameter, but the supplied ElectronicSerialNumber parameter does not match the ESN of the routed call. 9
10
11
12

Notes: 13

- a. This Error Code is not an appropriate MSC response to a RedirectionRequest transaction. 14
- b. It is recommended that an Originating MSC supports RedirectionRequest transactions. 15
- c. Only RETURN RESULT operations needing clarification have been included. 16
17
- d. Include the *Parameter Identifier* in question as the FaultyParameter parameter. 18
19

4.36 REDIRECTION REQUEST 20 21

4.36.1 MSC Initiating a Redirection Request 22 23 24

When an MSC determines that it needs to redirect the call, it shall perform the following: 25
26

- 1 Relay the parameters set by the calling task. 27
28
- 2 Send a RedirectionRequest INVOKE to the Originating MSC that is associated with this incoming call. 29
30
31
- 3 Start the Redirection Request Timer (RDRT). 32
- 4 WAIT for a Redirection Request response: 33
- 5 WHEN a RETURN RESULT is received: 34
35
 - 5-1 Stop timer (RDRT). 36
 - 5-2 IF the message can be processed: 37
38
 - 5-2-1 Execute the call release procedures. 39
 - 5-3 ELSE (the message cannot be processed): 40
41
 - 5-3-1 IF the MSC is provisioned to re-try failed Redirection Requests: 42
43
 - 5-3-1-1 Execute the “MSC Initiating a Transfer-To-Number Request” task (see 4.49.1). 44
45
 - 5-3-2 ENDIF. 46
 - 5-3-3 Execute “Local Recovery Procedures” task (see 3.5.1). 47
 - 5-4 ENDIF. 48
49
- 6 WHEN the call disconnects: 50
51
 - 6-1 Execute the call release procedures. 52
 - 6-2 Remain in this state (to clean up properly). 53
- 7 WHEN a RETURN ERROR or REJECT is received: 54
55
 - 7-1 Stop timer (RDRT). 56
 - 7-2 IF the MSC is provisioned to re-try failed Redirection Requests: 57
58
59
60

- 1 7-2-1 Execute the “MSC Initiating a Transfer-To-Number Request ” task (see
2 4.49.1).
3
4 7-3 ENDIF.
5 7-4 Execute “Local Recovery Procedures ” task (see 3.5.1).
6
7 8 WHEN timer (RDRT) expires:
8 8-1 IF the MSC is provisioned to re-try failed Redirection Requests:
9 8-1-1 Execute the “MSC Initiating a Transfer-To-Number Request ” task (see
10 4.49.1).
11 8-2 ENDIF.
12 8-3 Execute “Local Recovery Procedures ” task (see 3.5.1).
13
14 9 ENDWAIT.
15
16 10 Exit this task.

4.36.2 MSC Receiving RedirectionRequest INVOKE

When an MSC receives a RedirectionRequest INVOKE, it shall perform the following:

- 1 IF the received message can be processed:
2
3 1-1 IF there is a call or leg in progress that is associated with the received BillingID
4 and MobileIdentificationNumber parameters:
5
6 1-1-1 Execute the “MSC Initiating a Transfer-To-Number Request” task (see
7 4.49.1).
8
9 1-1-2 IF the task is successful:
10 1-1-2-1 Send a RETURN RESULT to the requesting MSC.
11 1-1-2-2 Exit this task.
12 1-1-3 ELSE:
13 1-1-3-1 Execute “Local Recovery Procedures” task (see 3.5.1).
14 1-1-3-2 Send a RETURN ERROR with a proper Error Code value (see the
15 following table) to the requesting MSC.
16 1-1-3-3 Exit this task.
17 1-1-4 ENDIF.
18 1-2 ELSE (there is no such call in progress):
19 1-2-1 Execute “Local Recovery Procedures ” task (see 3.5.1).
20 1-2-2 Send a RETURN ERROR with a proper Error Code value (see the following
21 table) to the requesting MSC.
22 1-2-3 Exit this task.
23 1-3 ENDIF.
24 2 ELSE (the received message cannot be processed):
25 2-1 Execute “Local Recovery Procedures ” task (see 3.5.1).
26 2-2 Send a RETURN ERROR with a proper Error Code value (see the following
27 table) to the requesting MSC.
28 3 ENDIF.
29 4 Exit this task.

Table 48 Originating MSC RedirectionRequest Response

Problem Detection and Recommended Response from Originating MSC to Serving MSC										
PROBLEM DEFINITION	1	2	3	4	5	6	7	8	9	Notes
RETURN ERROR Error Code										
<i>UnrecognizedMIN</i>						X				
<i>UnrecognizedESN</i>							X			
<i>MIN/HLRMismatch</i>										a
<i>OperationSequenceProblem</i>								X		
<i>ResourceShortage</i>		X								
<i>OperationNotSupported</i>	X									b
<i>TrunkUnavailable</i>										a
<i>ParameterError</i>				X						d
<i>SystemFailure</i>			X							
<i>UnrecognizedParameterValue</i>					X					d
<i>FeatureInactive</i>									X	
<i>MissingParameter</i>										a
RETURN RESULT										c

Problem Detections:

1. The requested MAP operation is recognized, but not supported, by the receiving Originating MSC, or the requesting functional entity is not authorized.
2. A required Originating MSC resource (e.g., internal memory record, MSC is fully occupied) is temporarily not available (e.g., congestion).
3. A required resource (e.g., data base access, functional entity) is not presently accessible due to a failure or the Digits (Destination) parameter received from the HLR is not acceptable. Human intervention may be required for resolution.
4. A supplied parameter value has an encoding problem (e.g., The supplied MobileIdentificationNumber parameter digit values do not meet the BCD specification).
5. A supplied parameter value is unrecognized or has nonstandard values (e.g., *Not used*, the Originating MSC does not presently have a routed call attempt active for the supplied BillingID parameter).
6. The Originating MSC does not presently have a routed call attempt active for the supplied MobileIdentificationNumber parameter.
7. The Originating MSC has a routed call attempt active for the supplied MobileIdentificationNumber parameter, but the supplied ElectronicSerialNumber parameter does not match the ESN of the routed call.
8. The Originating MSC has a routed call attempt active for the supplied MobileIdentificationNumber parameter, but the call state is not appropriate (e.g., in the *Conversation* state) for redirecting the call.
9. The Originating MSC has a routed call attempt active for the supplied MobileIdentificationNumber parameter, but the attempt to retrieve the appropriate Call Forwarding number resulted in failure because the feature was not active.

Notes:

- a. This Error Code is not an appropriate MSC response to a RedirectionRequest transaction.
- b. It is recommended that an Originating MSC supports RedirectionRequest transactions.
- c. Only RETURN RESULT operations needing clarification have been included.
- d. Include the *Parameter Identifier* in question as the FaultyParameter parameter.

4.37 REGISTRATION CANCELLATION

4.37.1 HLR Initiating Registration Cancellation

When an HLR detects that an MS is newly registered with a VLR that is different from the previously registered one, it shall perform the following:

- 1 Include the CancellationType parameter set to the type of cancellation desired.
- 2 IF applicable:
 - 2-1 Relay any received parameters from the RegistrationNotification INVOKE.
 - 3 ENDIF.
 - 4 Send a RegistrationCancellation INVOKE to the previously visited VLR.
 - 5 Start Registration Cancellation Timer (RCT).
 - 6 WAIT for a Registration Cancellation response:
 - 7 WHEN a RETURN RESULT is received:
 - 7-1 Stop timer (RCT).
 - 7-2 IF the message can be processed:
 - 7-2-1 IF the CancellationDenied parameter was not present:
 - 7-2-1-1 IF the CallHistoryCount (COUNT) parameter was received from the previously visited VLR:
 - 7-2-1-1-1 IF SharedSecretData (SSD) is shared with the previously visited VLR:
 - 7-2-1-1-1-1 IF the CallHistoryCount (COUNT) must be updated in the AC.
 - 7-2-1-1-1-1-1 Include the MobileIdentificationNumber parameter set to identify the MS.
 - 7-2-1-1-1-1-2 Include the ElectronicSerialNumber parameter set to identify the MS.
 - 7-2-1-1-1-1-3 Relay the received CallHistoryCount (COUNT) parameter.
 - 7-2-1-1-1-1-4 Send an MSInactive INVOKE to the MS's AC.
 - 7-2-1-1-1-1-5 Start the MS Inactive Timer (MSIT).
 - 7-2-1-1-1-1-6 WAIT for an MS Inactive Response:
 - 7-2-1-1-1-1-7 WHEN a RETURN RESULT is received:
 - 7-2-1-1-1-1-7-1 Stop the timer (MSIT).
 - 7-2-1-1-1-1-8 WHEN a RETURN ERROR or REJECT is received:
 - 7-2-1-1-1-1-8-1 Stop the timer (MSIT).
 - 7-2-1-1-1-1-8-2 Execute "Local Recovery Procedures" task (see 3.5.1).
 - 7-2-1-1-1-1-9 WHEN the timer (MSIT) expires:
 - 7-2-1-1-1-1-9-1 Execute "Local Recovery Procedures" task (see 3.5.1).
 - 7-2-1-1-1-1-10 ENDWAIT.
 - 7-2-1-1-1-2 ENDIF.
 - 7-2-1-1-2 ENDIF.
 - 7-2-1-2 ENDIF.

7-2-1-3 Clear the pointer to the previously visited VLR. 1
7-2-1-4 IF the SMS_MessageWaitingIndicator parameter was present: 2
7-2-1-4-1 Set the SMS_Delivery Pending Flag for this MS. 3
7-2-1-5 ENDIF. 4
7-2-2 ELSE return the CancellationDenied parameter to the calling process. 5
7-2-3 ENDIF. 6
7-3 ELSE (the message cannot be processed): 7
7-3-1 Execute "Local Recovery Procedures " task (see 3.5.1). 8
7-4 ENDIF. 9
8 WHEN a RETURN ERROR or REJECT is received: 10
8-1 Stop timer (RCT). 11
8-2 Execute "Local Recovery Procedures " task (see 3.5.1). 12
9 WHEN timer (RCT) expires: 13
9-1 Execute "Local Recovery Procedures " task (see 3.5.1). 14
10 ENDWAIT. 15
11 Return to the calling task. 16

4.37.2 VLR Receiving RegistrationCancellation INVOKE

When a VLR receives a RegistrationCancellation INVOKE, it shall perform the following:

1 IF the received message can be processed: 17
1-1 IF the ReceivedSignalQuality and ControlChannelData parameters are received 18
in the message:¹ 19
1-1-1 IF the VLR determines that the RegistrationCancellation INVOKE and the last 20
RegistrationNotification INVOKE were caused by the same access from the 21
MS: 22
1-1-1-1 IF the VLR determines (using internal algorithms and local operating 23
procedures) that the MS is still present within its domain: 24
1-1-1-1-1 Include the CancellationDenied parameter set to *Multiple Access*. 25
1-1-1-1-2 IF available: 26
1-1-1-1-2-1 Include the ReceivedSignalQuality, ControlChannelData and 27
SystemAccessData parameters set according to the values 28
received with the previous RegistrationNotification INVOKE. 29
1-1-1-1-3 ENDIF. 30
1-1-1-1-4 Send a RETURN RESULT to the requesting HLR. 31
1-1-1-1-5 Exit this task. 32
1-1-1-2 ENDIF. 33
1-1-2 ENDIF. 34
1-2 ENDIF. 35

¹The VLR may record the time at which the message was received as described in informative Annex F. 36

1-3 Relay all received parameters (including CancellationType (if received)).

1-4 Start the Registration Cancellation Timer (RCT).

1-5 Send a RegistrationCancellation INVOKE to the MS's previous Serving MSC.

1-6 WAIT for a Registration Cancellation response:

1-7 WHEN a RETURN RESULT is received:

1-7-1 Stop timer (RCT).

1-7-2 IF the message can be processed:

1-7-2-1 IF the CancellationDenied is not received:

1-7-2-1-1 IF SharedSecretData (SSD) is shared:

1-7-2-1-1-1 Include the CallHistoryCount (COUNT) parameter.

1-7-2-1-2 ENDIF.

1-7-2-1-3 Remove the record of the indicated MS.

1-7-2-2 ENDIF.

1-7-2-3 Relay any received parameters.

1-7-2-4 Send a RETURN RESULT to the requesting HLR.

1-7-3 ELSE (the message cannot be processed):

1-7-3-1 Send a RETURN ERROR with Error Code *SystemFailure*.

1-7-3-2 Execute "Local Recovery Procedures" task (see 3.5.1).

1-7-4 ENDIF.

1-8 WHEN a RETURN ERROR or REJECT is received:

1-8-1 Stop timer (RCT).

1-8-2 Execute "Local Recovery Procedures" task (see 3.5.1).

1-8-3 CASE Error Code OF:

1-8-4 *ParameterError*:

1-8-4-1 IF the parameter was originated from the initiating functional entity:

1-8-4-1-1 Send a RETURN ERROR with Error Code *ParameterError*.

1-8-4-2 ELSE:

1-8-4-2-1 Send a RETURN ERROR with Error Code *SystemFailure*.

1-8-4-3 ENDIF.

1-8-5 *OperationSequenceProblem*:

1-8-5-1 Send a RETURN ERROR with Error Code *OperationSequenceProblem*.

1-8-6 *DEFAULT*:

1-8-6-1 Send a RETURN ERROR with Error Code *SystemFailure*.

1-8-7 ENDCASE.

1-9 WHEN timer (RCT) expires:

1-9-1 Send a RETURN ERROR with Error Code *SystemFailure*.

1-9-2 Execute "Local Recovery Procedures" task (see 3.5.1).

1-10 ENDWAIT.

2 ELSE (the received message cannot be processed):

2-1 Send a RETURN ERROR with a proper value (see the following table) to the requesting HLR.

- 3 ENDIF.
- 4 Exit this task.

Table 49 VLR RegistrationCancellation Response

| Problem Detection and Recommended Response from VLR to HLR | | | | | | | | |
|--|---|---|---|---|---|---|---|-------|
| PROBLEM DEFINITION | 1 | 2 | 3 | 4 | 5 | 6 | 7 | Notes |
| RETURN ERROR
Error Code | | | | | | | | |
| <i>UnrecognizedMIN</i> | | | | | | | | a, e |
| <i>UnrecognizedESN</i> | | | | | X | | | |
| <i>MIN/HLRMismatch</i> | | | | | | | | a |
| <i>OperationSequenceProblem</i> | | | | | | X | | |
| <i>ResourceShortage</i> | | X | | | | | | |
| <i>OperationNotSupported</i> | X | | | | | | | b |
| <i>TrunkUnavailable</i> | | | | | | | | a |
| <i>ParameterError</i> | | | | X | | | | d |
| <i>SystemFailure</i> | | | X | | | | | |
| <i>UnrecognizedParameterValue</i> | | | | | | | | a |
| <i>FeatureInactive</i> | | | | | | | | a |
| <i>MissingParameter</i> | | | | | | | | a |
| RETURN RESULT | | | | | | | X | c |

Problem Detections:

1. A requested MAP operation is recognized, but not supported, by the receiving VLR, or the requesting functional entity is not authorized.
2. A required VLR resource (e.g., internal memory record, VLR is fully occupied) is temporarily not available (e.g., congestion).
3. A required resource (e.g., data base access, functional entity) is not presently accessible due to a failure. Human intervention may be required for resolution.
4. A supplied parameter has an encoding problem (e.g., the supplied MobileIdentificationNumber parameter digit values do not meet the BCD specification).
5. A VLR record exists for the supplied MobileIdentificationNumber parameter, but the supplied ElectronicSerialNumber parameter does not match the ESN in the VLR record.
6. A VLR record exists for the supplied MobileIdentificationNumber parameter, but the MIN is presently active in a call.
7. A VLR record does not exist for the supplied MobileIdentificationNumber parameter.

Notes:

- a. This Error Code is not an appropriate VLR response to a RegistrationCancellation transaction.
- b. It is recommended that a VLR support RegistrationCancellation transactions.
- c. Only RETURN RESULT operations needing clarification have been included.
- d. Include the *Parameter Identifier* in question as the FaultyParameter parameter.
- e. A RETURN RESULT response should be provided, see Problem Detection 7.

4.37.3 VLR Initiating Registration Cancellation

When a VLR detects that an MS is no longer registered in an MSC, it shall perform the following:

- 1 Include the CancellationType parameter set to the desired type.

- 2 Start the Registration Cancellation Timer (RCT).
- 3 Send a RegistrationCancellation INVOKE to the MS's previous Serving MSC.
- 4 WAIT for a RegistrationCancellation response:
- 5 WHEN a RETURN RESULT is received:
 - 5-1 Stop timer (RCT).
 - 5-2 IF the message can be processed:
 - 5-2-1 IF the CancellationDenied parameter is received:
 - 5-2-1-1 Update the location of the MS.
 - 5-2-2 ELSE:
 - 5-2-2-1 Return all received parameters to the calling task.
 - 5-2-3 ENDIF.
 - 5-3 ELSE (the message cannot be processed):
 - 5-3-1 Execute "Local Recovery Procedures" task (see 3.5.1).
 - 5-4 ENDIF.
- 6 WHEN a RETURN ERROR is received:
 - 6-1 Stop timer (RCT).
 - 6-2 Execute "Local Recovery Procedures " task (see 3.5.1).
- 7 WHEN timer (RCT) expires:
 - 7-1 Execute "Local Recovery Procedures " task (see 3.5.1).
- 8 ENDWAIT.
- 9 Exit this task.

4.37.4 MSC Receiving RegistrationCancellation INVOKE

When an MSC receives a RegistrationCancellation INVOKE it shall perform the following:

- 1 IF the received message can be processed:
 - 1-1 IF the CancellationType parameter is received:
 - 1-1-1 IF the CancellationType is *Discontinue*:
 - 1-1-1-1 IF the indicated MS is involved in a call or service operation anchored by this MSC:
 - 1-1-1-1-1 The Serving System shall discontinue the call or service operation currently in progress.
 - 1-1-1-2 ENDIF.
 - 1-1-1-3 IF the *SMS Delivery Pending Flag* is set for the indicated MS:
 - 1-1-1-3-1 Include the SMS_MessageWaitingIndicator parameter.
 - 1-1-1-4 ENDIF.
 - 1-1-1-5 Remove the record of the indicated MS including the *SMS Delivery Pending Flag*.
 - 1-1-2 ELSEIF the CancellationType is *ReportInCall*:
 - 1-1-2-1 IF the indicated MS is involved in a call or service operation anchored by this MSC:
 - 1-1-2-1-1 Include CancellationDenied parameter set to *Busy*.

| | | |
|-------------|---|----|
| | (Do not communicate the <i>SMS Delivery Pending Flag</i> state. | 1 |
| 1-1-2-2 | ELSE: | 2 |
| 1-1-2-2-1 | IF the <i>SMS Delivery Pending Flag</i> is set for the indicated MS: | 3 |
| 1-1-2-2-1-1 | Include the <i>SMS_MessageWaitingIndicator</i> parameter. | 4 |
| 1-1-2-2-2 | ENDIF. | 5 |
| 1-1-2-2-3 | Remove the record of the indicated MS including the <i>SMS Delivery Pending Flag</i> . | 6 |
| 1-1-2-3 | ENDIF. | 7 |
| 1-1-3 | ELSEIF the indicated MS is involved in a call or service operation anchored by this MSC: | 8 |
| 1-1-3-1 | The Serving System may optionally discontinue the call or service operation currently in progress. | 9 |
| 1-1-3-2 | IF the <i>SMS Delivery Pending Flag</i> is set for the indicated MS: | 10 |
| 1-1-3-2-1 | Include the <i>SMS_MessageWaitingIndicator</i> parameter. | 11 |
| 1-1-3-3 | ENDIF. | 12 |
| 1-1-3-4 | Remove the record of the indicated MS including the <i>SMS Delivery Pending Flag</i> . | 13 |
| 1-1-4 | ENDIF. | 14 |
| 1-2 | ELSE (CancellationType parameter was not included): | 15 |
| 1-2-1 | IF the indicated MS is involved in a call or service operation anchored by this MSC: | 16 |
| 1-2-1-1 | The Serving System may optionally discontinue the call or service operation currently in progress. | 17 |
| 1-2-2 | ENDIF. | 18 |
| 1-2-3 | IF the <i>SMS Delivery Pending Flag</i> is set for the indicated MS: | 19 |
| 1-2-3-1 | Include the <i>SMS_MessageWaitingIndicator</i> parameter. | 20 |
| 1-2-4 | ENDIF. | 21 |
| 1-2-5 | Remove the record of the indicated MS including the <i>SMS Delivery Pending Flag</i> . | 22 |
| 1-3 | ENDIF. | 23 |
| 1-4 | Send a RETURN RESULT to the requesting VLR. | 24 |
| 2 | ELSE (the received message cannot be processed): | 25 |
| 2-1 | Send a RETURN ERROR with a proper Error Code value (see the following table) to the requesting VLR. | 26 |
| 3 | ENDIF. | 27 |
| 4 | Exit this task. | 28 |
| | | 29 |
| | | 30 |
| | | 31 |
| | | 32 |
| | | 33 |
| | | 34 |
| | | 35 |
| | | 36 |
| | | 37 |
| | | 38 |
| | | 39 |
| | | 40 |
| | | 41 |
| | | 42 |
| | | 43 |
| | | 44 |
| | | 45 |
| | | 46 |
| | | 47 |
| | | 48 |
| | | 49 |
| | | 50 |
| | | 51 |
| | | 52 |
| | | 53 |
| | | 54 |
| | | 55 |
| | | 56 |
| | | 57 |
| | | 58 |
| | | 59 |
| | | 60 |

Table 50 MSC RegistrationCancellation Response

| Problem Detection and Recommended Response from MSC to VLR | | | | | | | | |
|--|---|---|---|---|---|---|---|-------|
| PROBLEM DEFINITION | 1 | 2 | 3 | 4 | 5 | 6 | 7 | Notes |
| RETURN ERROR
Error Code | | | | | | | | |
| <i>UnrecognizedMIN</i> | | | | | | | | a, e |
| <i>UnrecognizedESN</i> | | | | | X | | | |
| <i>MIN/HLRMismatch</i> | | | | | | | | a |
| <i>OperationSequenceProblem</i> | | | | | | X | | |
| <i>ResourceShortage</i> | | X | | | | | | |
| <i>OperationNotSupported</i> | X | | | | | | | b |
| <i>TrunkUnavailable</i> | | | | | | | | a |
| <i>ParameterError</i> | | | | X | | | | d |
| <i>SystemFailure</i> | | | X | | | | | |
| <i>UnrecognizedParameterValue</i> | | | | | | | | a |
| <i>FeatureInactive</i> | | | | | | | | a |
| <i>MissingParameter</i> | | | | | | | | a |
| RETURN RESULT | | | | | | | X | c |

Problem Detections:

1. A requested MAP operation is recognized, but not supported, by the receiving MSC, or the requesting functional entity is not authorized.
2. A required MSC resource (e.g., internal memory record, MSC is fully occupied) is temporarily not available (e.g., congestion).
3. A required resource (e.g., data base access, functional entity) is not presently accessible due to a failure. Human intervention may be required for resolution.
4. A supplied parameter has an encoding problem (e.g., the supplied MobileIdentificationNumber parameter digit values do not meet the BCD specification).
5. An MSC record exists for the supplied MobileIdentificationNumber parameter, but the supplied ElectronicSerialNumber parameter does not match the ESN in the MSC record.
6. An MSC record exists for the supplied MobileIdentificationNumber parameter, but the MIN is presently active in a call.
7. An MSC record does not exist for the supplied MobileIdentificationNumber parameter.

Notes:

- a. This Error Code is not an appropriate MSC response to a RegistrationCancellation transaction.
- b. It is recommended that an MSC supports RegistrationCancellation transactions.
- c. Only RETURN RESULT operations needing clarification have been included.
- d. Include the *Parameter Identifier* in question as the FaultyParameter parameter.
- e. A RETURN RESULT response should be provided, see Problem Detection 7.

4.38 REGISTRATION NOTIFICATION**4.38.1 MSC Initiating MS Registration**

When an MSC determines that a roaming Mobile Station (MS) is now within its service area (through autonomous registration, call origination, call termination (e.g., a page response following a call to the roamer access number), or other mechanism, except for

detection by a call handoff), this new Serving MSC shall start the registration notification process by doing the following:

- 1 Include the `QualificationInformationCode` parameter set according to the information needed from the VLR.
- 2 Include the `SystemAccessType` parameter set to the type of access performed by the MS.
- 3 IF the access occurred in a border cell:
 - 3-1 Include the `BorderCellAccess` parameter with a value of *Border cell access*.
 - 3-2 The MSC should include the `ReceivedSignalQuality` parameter set to the signal strength of the received access.
 - 3-3 The MSC should include the `ControlChannelData` parameter set to the Control Channel Identification information.
 - 3-4 The MSC should include the `SystemAccessData` parameter set to the cell site information._
- 4 ENDIF.
- 5 IF the MSC is authentication capable:
 - 5-1 Include the `SystemCapabilities (SYSCAP)` parameter set to indicate the authentication-related capabilities of this system.
- 6 IF authentication parameters were requested (i.e., `AUTH=1` in the Overhead Message Train), but were not received from the MS on the system access:
 - 6-1 Include the `ReportType (RPTTYP)` parameter indicating *Missing authentication parameters*.
- 7 ENDIF.
- 8 Include the `ElectronicSerialNumber` parameter set to identify the MS.
- 9 Include the `MobileIdentificationNumber` parameter set to identify the MS.
- 10 Include the `MSCID` parameter set to the identity of the MSC.
- 11 Include the `SystemMyTypeCode` parameter set to the MSC's manufacturer.
- 12 Include the `TerminalType (TERMTYP)` parameter as declared by the MS.
- 13 IF the MSC is sending the message to an SS7 network:
 - 13-1 Include the `PC_SSN` parameter with the `Type` set to *Serving MSC* and the `PC` and `SSN` fields set to the MSC's point code and subsystem number.
- 14 ENDIF.
- 15 IF the MS and MSC are SMS capable:
 - 15-1 Include the `SMS_Address` parameter set to be used to route SMS messages to the MS.
- 16 ENDIF.
- 17 IF the MSC supports local SPINI operation:
 - 17-1 Include the `TransactionCapability` parameter indicating local SPINI operation supported.
- 18 ENDIF.
- 19 IF the MS is intentionally inaccessible for normal Call Delivery for periods of time (e.g., using a slotted mode, paging frame class, or sleep mode):
 - 19-1 Include the `AvailabilityType` parameter set to `AvailabilityType: Unspecified mobile inactivity type`.

1 20 ENDIF.

2

3 21 Send a RegistrationNotification INVOKE to the MSC's associated VLR.

4 22 Start the Registration Notification Timer (RNT).

5 23 WAIT for a Registration Notification response:

6

7 24 WHEN a RETURN RESULT is received:

8

9 24-1 Stop timer (RNT).

10 24-2 IF the message can be processed:

11 24-2-1 IF the message contained an AuthorizationDenied parameter:

12 24-2-1-1 IF the indicated MS is involved in a call or service operation anchored by

13 this MSC:

14

15 24-2-1-1-1 The Serving System may optionally discontinue the call or service

16 operation currently in progress.

17

18 24-2-1-2 ENDIF.

19 24-2-1-3 IF a record exists for the indicated MS:

20 24-2-1-3-1 Clear the subscriber's profile.

21

22 24-2-1-4 ENDIF.

23 24-2-2 ELSE:

24 24-2-2-1 Update the MS's service profile and qualification information with the

25 received parameters.

26

27 24-2-2-2 IF the SMS_MessageWaitingIndicator parameter was received:

28 24-2-2-2-1 Set the *SMS Delivery Pending Flag* for this MS.

29

30 24-2-2-3 ENDIF.

31 24-2-2-4 Execute the "MSC MWN Status Change Invocation" task (see 5.13.9).

32 24-2-2-5 IF the indicated MS is involved in a call or service operation anchored by

33 this MSC:

34

35 24-2-2-5-1 IF the service profile parameters do not authorize the current call or

36 service operation:

37 24-2-2-5-1-1 The Serving System may optionally discontinue the call or

38 service operation currently in progress.

39

40 24-2-2-5-2 ENDIF.

41 24-2-2-6 ENDIF.

42

43 24-2-3 ENDIF.

44 24-3 ELSE (the message cannot be processed):

45 24-3-1 Execute "Local Recovery Procedures" task (see 3.5.1).

46

47 24-4 ENDIF.

48 25 WHEN a RETURN ERROR OR REJECT is received:

49

50 25-1 Stop timer (RNT).

51 25-2 Execute "Local Recovery Procedures " task (see 3.5.1).

52

53 26 WHEN timer (RNT) expires:

54 26-1 Execute "Local Recovery Procedures " task (see 3.5.1).

55

56 27 ENDWAIT.

57 28 Exit this task.

58

59

60

4.38.2 VLR Receiving RegistrationNotification INVOKE

When a VLR receives a RegistrationNotification INVOKE, it shall perform the following:

- 1 IF the received message cannot be processed:
 - 1-1 Send a RETURN ERROR with a proper Error Code value (see the following table) to the requesting MSC.
 - 1-2 Exit this task.
 - 2 ENDIF.
 - 3 IF the MS is not allowed to register (e.g., the MS is on a negative list or registration attempts for the MS from same MSCID and LocationAreaID have failed in the recent past or the request is within a *denied authorization period*):
 - 3-1 Include the AuthorizationDenied parameter set to *Unspecified*.
 - 3-2 Include the SystemMyTypeCode parameter set to the VLR's manufacturer.
 - 3-3 Send a RETURN RESULT to the requesting MSC.
 - 3-4 Exit this task.
 - 4 ENDIF.
- (The MS is allowed to register.)
- 5 IF the SystemAccessType parameter indicates *Autonomous registration*:¹
 - 5-1 IF the VLR detects a multiple access situation (e.g., due to unavailability of SignalQuality data):
 - 5-1-1 IF this registration is not the most desirable access:
 - 5-1-1-1 Include the AuthorizationDenied parameter set to *Multiple Access*.
 - 5-1-1-2 IF available:
 - 5-1-1-2-1 Include the ReceivedSignalQuality, ControlChannelData and SystemAccessData parameters set according to the values received with the best RegistrationNotification INVOKE for this access.
 - 5-1-1-3 ENDIF.
 - 5-1-1-4 Include the SystemMyTypeCode parameter set to the VLR's manufacturer.
 - 5-1-1-5 Send a RETURN RESULT to the requesting MSC.
 - 5-1-1-6 Exit this task.
 - 5-1-2 ENDIF.
 - 5-2 ENDIF.
 - 6 ENDIF.
- (The registration is acceptable according to the VLR's data.)
- 7 IF the ReceivedSignalQuality, ControlChannelData and SystemAccessData parameters are received:
 - 7-1 Record them.
 - 8 ENDIF.

¹The VLR may mark the time at which the message was received as described in informative Annex F.

1
2
3
4
5
6
7
8
9
10
11
12
13
14
15
16
17
18
19
20
21
22
23
24
25
26
27
28
29
30
31
32
33
34
35
36
37
38
39
40
41
42
43
44
45
46
47
48
49
50
51
52
53
54
55
56
57
58
59
60

```

9  IF the LocationAreaID parameter was received:
9-1  Record the location area identifier. (Note changes for below.)
10  ENDIF.
11  Record the received MSCID as the identity of the MSC currently serving the MS. (Note
    changes for below.)
12  IF the MS has registered with an MSC within the domain of the VLR:
12-1  IF the MSC currently serving the MS is not the MSC previously registered with the
      VLR:
12-1-1  Execute the "VLR Initiating Registration Cancellation" task (see 4.37.3).
12-1-2  IF the SMS_MessageWaitingIndicator parameter was received with the
      RegistrationCancellation RETURN RESULT;
12-1-2-1  Relay the SMS_MessageWaitingIndicator parameter (for the
      RegistrationNotification INVOKE to be sent to the HLR).
12-1-2-2  GOTO Register the MS.
12-1-3  ENDIF.
12-2  ENDIF.
12-3  IF the AvailabilityType parameter is received:
12-3-1  IF the MS is in the active state:
12-3-1-1  GOTO Register the MS.
12-3-2  ENDIF.
12-4  ELSE (the AvailabilityType parameter is not received):
12-4-1  IF the MS is in the inactive state:
12-4-1-1  GOTO Register the MS.
12-4-2  ENDIF.
12-5  ENDIF.
      (The MS has not changed its active or inactive state.)
12-6  IF the MS has changed Market IDs and the GeographicAuthorization parameter
      indicates that it was Authorized for this MarketID only:
12-6-1  GOTO Register the MS.
12-7  ELSEIF the MS has changed MSCs and the GeographicAuthorization parameter
      indicates that it was Authorized for this MarketID and Switch Number only.
12-7-1  GOTO Register the MS.
12-8  ELSEIF the MS has changed location areas within an MSC and the
      GeographicAuthorization parameter indicates that it was Authorized for
      thisLocationAreaID within a MarketID only:
12-8-1  GOTO Register the MS.
12-9  ELSEIF the MS has changed cells within an MSC and the
      GeographicAuthorization parameter indicates that it was Authorized for this cell
      only:
12-9-1  GOTO Register the MS.
12-10  ENDIF.
      (The MS is geographically authorized.)
12-11  IF an SMS_Address parameter is received:

```

| | | |
|-----------|---|----|
| 12-11-1 | IF the SMS_Address is different than the current SMS temporary routing address: | 1 |
| | | 2 |
| 12-11-1-1 | GOTO Register the MS. | 3 |
| | | 4 |
| 12-11-2 | ENDIF. | 5 |
| | | 6 |
| 12-12 | ELSE: | 7 |
| 12-12-1 | IF an SMS temporary routing address exists: | 8 |
| 12-12-1-1 | Clear the SMS temporary routing address. | 9 |
| | | 10 |
| 12-12-1-2 | GOTO Register the MS (to report loss of SMS capability). | 11 |
| 12-12-2 | ENDIF. | 12 |
| | | 13 |
| 12-13 | ENDIF. | 14 |
| 12-14 | IF the information requested by the QualificationInformationCode is available: | 15 |
| 12-14-1 | IF the QualificationInformationCode indicates <i>Profile only</i> or <i>Validation and profile</i> : | 16 |
| | | 17 |
| 12-14-1-1 | Execute the "Loading of Profile Parameters" task (see 3.1.3). | 18 |
| | | 19 |
| 12-14-2 | ENDIF. | 20 |
| | | 21 |
| 12-14-3 | IF the QualificationInformationCode indicates <i>Validation only</i> or <i>Validation and profile</i> : | 22 |
| | | 23 |
| 12-14-3-1 | Include the AuthorizationPeriod parameter set appropriately. | 24 |
| 12-14-4 | ENDIF. | 25 |
| | | 26 |
| 12-14-5 | Send a RETURN RESULT to the requesting MSC. | 27 |
| 12-14-6 | Exit this task. | 28 |
| | | 29 |
| 12-15 | ENDIF. | 30 |
| 13 | ENDIF. | 31 |
| | | 32 |
| | | 33 |
| 14 | IF the AvailabilityType parameter was received: | 34 |
| 14-1 | Set the MS's state to <i>inactive</i> . | 35 |
| | | 36 |
| 15 | ELSE: | 37 |
| 15-1 | Set the MS's state to <i>active</i> . | 38 |
| | | 39 |
| 16 | ENDIF. | 40 |
| 17 | IF the SMS_Address is received: | 41 |
| 17-1 | Optionally store it as the SMS temporary routing address. | 42 |
| | | 43 |
| 18 | ELSE: | 44 |
| 18-1 | Clear the SMS temporary routing address. | 45 |
| | | 46 |
| 19 | ENDIF. | 47 |
| 20 | IF available: | 48 |
| 20-1 | Relay the received BorderCellAccess, SignalQuality, ControlChannelData and SystemAccessType parameters. | 49 |
| | | 50 |
| 21 | ENDIF. | 51 |
| | | 52 |
| 22 | Relay any parameters received in the RegistrationNotification INVOKE including the MSCID . | 53 |
| | | 54 |
| 23 | IF the Serving MSC identity is not equal to the VLR's ID information: | 55 |
| | | 56 |
| | | 57 |
| | | 58 |
| | | 59 |
| | | 60 |

1 23-1 Include the ExtendedMSCID (Serving) parameter set to the identity of the
2 VLR._
3
4 24 ENDIF.
5 25 Include the SenderIdentificationNumber set to the identification number of the VLR.
6
7 26 IF the VLR is sending the message to an SS7 network:
8 26-1 Include the PC_SSN parameter with the Type field set to *VLR* and the PC and
9 SSN fields set to the VLR's point code and subsystem number.
10 27 ENDIF.
11
12 28 Send a RegistrationNotification INVOKE to the HLR associated with the MS.
13 29 Start the Registration Notification Timer (RNT).
14 30 WAIT for a Registration Notification response:
15 31 WHEN a RETURN RESULT is received:
16 31-1 Stop timer (RNT).
17 31-2 IF the message can be processed:
18 31-2-1 IF the AuthorizationDenied parameter was received:
19 31-2-1-1 Relay the received AuthorizationDenied parameter and other received
20 parameters.
21 31-2-1-2 Include the SystemMyTypeCode parameter set to the VLR's
22 manufacturer.
23 31-2-1-3 Send a RETURN RESULT to the requesting MSC.
24 31-2-1-4 IF a record exists for the MS.
25 31-2-1-4-1 Clear the subscriber's profile.
26 31-2-1-5 ENDIF.
27 31-2-1-6 IF the AuthorizationDenied parameter indicated *Multiple Access*:
28 31-2-1-6-1 Remove the record of the MS. (Future registration attempts will be
29 allowed.)
30 31-2-1-7 ELSE:
31 31-2-1-7-1 The VLR may create a record in its internal data structures to indicate
32 Authorization Denied for the indicated MS to prevent repetitive
33 Registration Notification attempts.
34 31-2-1-7-2 IF the DeniedAuthorizationPeriod parameter is received:
35 31-2-1-7-2-1 Record the *denied authorization period* to prevent repetitive
36 RegistrationNotification attempts.
37 31-2-1-7-3 ELSE:
38 31-2-1-7-3-1 Record the *denied authorization period* according to the results
39 of internal algorithms to prevent repetitive
40 RegistrationNotification attempts.
41 31-2-1-7-3 ENDIF.
42 31-2-1-8 ENDIF.
43 31-2-1-9 Exit this task.
44 31-2-2 ENDIF.
45 31-2-3 IF no record exists for the indicated MS:
46 31-2-3-1 Create a record.
47
48
49
50
51
52
53
54
55
56
57
58
59
60

| | | |
|----------|--|----|
| 31-2-4 | ENDIF. | 1 |
| 31-2-5 | Update validation and restriction information. | 2 |
| 31-2-6 | Optionally update the indicated MS's service profile information. | 3 |
| 31-2-7 | IF the <i>SMS Delivery Pending Flag</i> is set for this MS: | 4 |
| 31-2-7-1 | Include the <i>SMS_MessageWaitingIndicator</i> parameter. | 5 |
| 31-2-8 | ENDIF. | 6 |
| 31-2-9 | Optionally include stored service profile parameters. | 7 |
| 31-2-10 | Relay any received parameters from the HLR. | 8 |
| 31-2-11 | Send a RETURN RESULT to the requesting MSC. | 9 |
| 31-3 | ELSE (the message cannot be processed): | 10 |
| 31-3-1 | Execute "Local Recovery Procedures" task (see 3.5.1). | 11 |
| 31-4 | ENDIF. | 12 |
| 32 | WHEN a RETURN ERROR OR REJECT is received: | 13 |
| 32-1 | Stop timer (RNT). | 14 |
| 32-2 | CASE Error Code OF: | 15 |
| 32-3 | <i>ParameterError</i> : | 16 |
| 32-3-1 | IF the parameter was originated from the initiating functional entity: | 17 |
| 32-3-1-1 | Send a RETURN ERROR with Error Code <i>ParameterError</i> . | 18 |
| 32-3-2 | ELSE: | 19 |
| 32-3-2-1 | Send a RETURN ERROR with Error Code <i>SystemFailure</i> . | 20 |
| 32-3-3 | ENDIF. | 21 |
| 32-4 | <i>OperationSequenceProblem</i> : | 22 |
| 32-4-1 | Send a RETURN ERROR with Error Code <i>OperationSequenceProblem</i> . | 23 |
| 32-5 | DEFAULT: | 24 |
| 32-5-1 | Send a RETURN ERROR with Error Code <i>SystemFailure</i> . | 25 |
| 32-6 | ENDCASE. | 26 |
| 32-7 | Execute "Local Recovery Procedures " task (see 3.5.1). | 27 |
| 33 | WHEN timer (RNT) expires: | 28 |
| 33-1 | Execute "Local Recovery Procedures " task (see 3.5.1). | 29 |
| 34 | ENDWAIT. | 30 |
| 35 | Exit this task. | 31 |
| | | 32 |
| | | 33 |
| | | 34 |
| | | 35 |
| | | 36 |
| | | 37 |
| | | 38 |
| | | 39 |
| | | 40 |
| | | 41 |
| | | 42 |
| | | 43 |
| | | 44 |
| | | 45 |
| | | 46 |
| | | 47 |
| | | 48 |
| | | 49 |
| | | 50 |
| | | 51 |
| | | 52 |
| | | 53 |
| | | 54 |
| | | 55 |
| | | 56 |
| | | 57 |
| | | 58 |
| | | 59 |
| | | 60 |

Table 51 VLR RegistrationNotification Response

| Problem Detection and Recommended Response from VLR to MSC | | | | | | | | | | | |
|--|---|---|---|---|---|---|---|---|---|----|-------|
| PROBLEM DEFINITION | 1 | 2 | 3 | 4 | 5 | 6 | 7 | 8 | 9 | 10 | Notes |
| RETURN ERROR | | | | | | | | | | | |
| Error Code | | | | | | | | | | | |
| <i>UnrecognizedMIN</i> | | | | | | | | | | | a |
| <i>UnrecognizedESN</i> | | | | | | | | | | | a |
| <i>MIN/HLRMismatch</i> | | | | | | X | | | | | e |
| <i>OperationSequenceProblem</i> | | | | | | | | | | | a |
| <i>ResourceShortage</i> | | X | | | | | | | | | e |
| <i>OperationNotSupported</i> | X | | | | | | | | | | b, e |
| <i>TrunkUnavailable</i> | | | | | | | | | | | a |
| <i>ParameterError</i> | | | | X | | | | | | | d |
| <i>SystemFailure</i> | | | X | | | | | | | | e |
| <i>UnrecognizedParameterValue</i> | | | | | X | | | | | | d, e |
| <i>FeatureInactive</i> | | | | | | | | | | | a |
| <i>MissingParameter</i> | | | | | | | X | | | | d, e |
| RETURN RESULT | | | | | | | | | | | c |
| Authori ationDenied | | | | | | | | | | | |
| <i>Delinquent Account</i> | | | | | | | | | | X | e |
| <i>Invalid Serial Number</i> | | | | | | | | X | | | e |
| <i>Stolen Unit</i> | | | | | | | | | | X | e |
| <i>Duplicate Unit</i> | | | | | | | | | | X | e |
| <i>Unassigned DirectoryNumber</i> | | | | | | | | X | | | e |
| <i>Unspecified</i> | | | | | | | | | | X | e |
| <i>Multiple access</i> | | | | | | | | | | X | e |
| <i>Not Authorized for the MSC</i> | | | | | | | | | | X | e |
| <i>Missing authenticationparameters</i> | | | | | | | | | | X | e |
| <i>TerminalType mismatch</i> | | | | | | | | | | X | e |

Problem Detections:

1. The requested MAP operation is recognized, but not supported, by the receiving VLR, or the requesting functional entity is not authorized.
2. A required VLR resource (e.g., internal memory record, VLR is fully occupied) is temporarily not available (e.g., congestion).
3. A required resource (e.g., data base access, functional entity) is not presently accessible due to a failure. Human intervention may be required for resolution.
4. A supplied parameter has an encoding problem (e.g., the supplied MobileIdentificationNumber parameter digit values do not meet the BCD specification).
5. A supplied parameter value is unrecognized or has nonstandard values (e.g., *Not used*).
6. The supplied MobileIdentificationNumber parameter's HLR responded that the MIN is not in the HLR's range of MINs or directory numbers (suspect routing error).
7. An expected, or required, optional parameter (e.g., PC_SSN) was not received.
8. An existing VLR record indicates (or the supplied MIN's HLR responded) that the MobileIdentificationNumber parameter is not presently assigned to a subscriber.
9. An existing VLR record indicates (or the supplied MIN's HLR responded) that the supplied ElectronicSerialNumber parameter is not valid for the MIN's record.
10. An existing VLR record indicates (or the supplied MIN's HLR responded) that the MIN is either a *Delinquent Account*, *Stolen Unit*, *Duplicate Unit*, *Unspecified*, *Multiple access*, *Not Authorized for the MSC*, *Missing authentication parameters*, or *TerminalType mismatch* .

Notes:

- a. This Error Code is not an appropriate VLR response to a RegistrationNotification transaction.
- b. It is recommended that a VLR support the RegistrationNotification transactions.
- c. Only RETURN RESULT operations needing clarification have been included.
- d. Include the *Parameter Identifier* in question as the FaultyParameter parameter.
- e. This response may have been originated by the HLR.

4.38.3 HLR Receiving RegistrationNotification INVOKE

When an HLR receives a RegistrationNotification INVOKE, it shall perform the following:

- 1 IF the received message can be processed and the requested information can be made available for the indicated MS):
 - 1-1 IF the received SystemAccessType parameter indicates *Autonomous registration*:²
 - 1-1-1 IF this RegistrationNotification is part of a multiple access situation (based on internal algorithms and local operating procedures):
 - 1-1-1-1 IF this is not the most desirable access:
 - 1-1-1-1-1 Include the AuthorizationDenied parameter set to *Multiple Access*.
 - 1-1-1-1-2 IF the measurement data is available:
 - 1-1-1-1-2-1 Include the ReceivedSignalQuality, ControlChannelData and SystemAccessData parameters set according to values received with the best RegistrationNotification INVOKE received for this access.
 - 1-1-1-1-3 ENDIF.
 - 1-1-1-1-4 Include the SystemMyTypeCode parameter set to the HLR's manufacturer.
 - 1-1-1-1-5 Send a RETURN RESULT to the requesting VLR.
 - 1-1-1-1-6 Exit this task.
 - 1-1-1-2 ENDIF.
 - 1-1-2 ENDIF.
 - 1-2 ENDIF.
- 1-3 IF the MS is authorized for service on this MSC:
 - 1-3-1 Update the current VLR location of the MS.
 - 1-3-2 IF the MS is registered with a different VLR:
 - 1-3-2-1 IF the received SystemAccessType parameter indicates *Autonomous registration*:
 - 1-3-2-1-1 IF the measurement data is available:
 - 1-3-2-1-1-1 Include the ReceivedSignalQuality, ControlChannelData and SystemAccessData parameters according to the values received with the best RegistrationNotification INVOKE received for this access.
 - 1-3-2-1-2 ENDIF.

²The HLR may record the time at which the message was received as described in informative Annex F.

1 1-3-2-2 ENDIF.

2 1-3-2-3 Execute the “HLR Initiating Registration Cancellation” task (see 4.37.1).

3

4 1-3-2-4 IF the CancellationDenied parameter is received:

5 1-3-2-4-1 Include the AuthorizationDenied parameter set to *Multiple Access*.

6 1-3-2-4-2 IF the measurement data is available:

7 1-3-2-4-2-1 Relay the ReceivedSignalQuality, ControlChannelData and

8 SystemAccessData parameters.

9

10 1-3-2-4-3 ENDIF.

11 1-3-2-4-4 Restore the current VLR location of the MS.

12 1-3-2-4-5 Include the SystemMyTypeCode parameter set to the HLR’s

13 manufacturer.

14 1-3-2-4-6 Send a RETURN RESULT to the requesting VLR.

15 1-3-2-4-7 Exit this task._

16 1-3-2-5 ELSE (no CancellationDenied parameter received):

17 1-3-2-5-1 Relay any received parameters, except the

18 SMS_MessageWaitingIndicator parameter, from the

19 RegistrationCancellation RETURN RESULT.

20 1-3-2-6 ENDIF.

21 1-3-3 ELSE (the MS is registered with the same VLR):

22 1-3-3-1 IF an SMS_MessageWaitingIndicator parameter was received:

23 1-3-3-1-1 Set the *SMS Delivery Pending Flag* for this MS.

24 1-3-3-2 ENDIF.

25 1-3-4 ENDIF.

26 1-3-5 IF the QualificationInformationCode indicates *Profile only* or *Validation*

27 *and profile*:

28 1-3-5-1 Execute the “Loading of Profile Parameters” task (see 3.1.3).

29 1-3-6 ENDIF.

30 1-3-7 IF the QualificationInformationCode indicates *Validation only* or *Validation*

31 *and profile*:

32 1-3-7-1 Include the AuthorizationPeriod parameter set appropriately.

33 1-3-8 ENDIF.

34 1-3-9 IF an SMS_Address parameter is received with the RegistrationNotification

35 INVOKE:

36 1-3-9-1 IF an AvailabilityType parameter is NOT received with the

37 RegistrationNotification INVOKE:

38 1-3-9-1-1 IF SMS service is authorized for the MS on the current serving

39 system:

40 1-3-9-1-1-1 IF the *SMS Delivery Pending Flag* is set for this MS:

41 1-3-9-1-1-1-1 Include the SMS_MessageWaitingIndicator parameter.

42 1-3-9-1-1-2 ENDIF.

43 1-3-9-1-2 ENDIF.

44 1-3-9-2 ENDIF.

45 1-3-10 ENDIF.

46

47

48

49

50

51

52

53

54

55

56

57

58

59

60

| | | |
|-------------|--|----|
| 1-4 | ELSE (the MS is not authorized for service): | 1 |
| 1-4-1 | Include the AuthorizationDenied parameter set to the proper value (see the following table): | 2 |
| 1-4-2 | IF applicable: | 3 |
| 1-4-2-1 | Include the DeniedAuthorizationPeriod parameter set appropriately. | 4 |
| 1-4-3 | ENDIF | 5 |
| 1-5 | ENDIF. | 6 |
| 1-6 | Include the SystemMyTypeCode parameter set to the HLR's manufacturer. | 7 |
| 1-7 | Send a RETURN RESULT to the requesting VLR. | 8 |
| 1-8 | IF an SMS_Address parameter was received in the RegistrationNotification INVOKE (this sequence is repeated only so that the SMSNotification is sent after the RegistrationNotification RETURN RESULT): | 9 |
| 1-8-1 | IF an AvailabilityType parameter was NOT received with the RegistrationNotification INVOKE: | 10 |
| 1-8-1-1 | IF SMS service is authorized for the MS on the current serving system: | 11 |
| 1-8-1-1-1 | Optionally set the temporary SMS routing address to the received SMS_Address. | 12 |
| 1-8-1-1-2 | IF the <i>SMS Delivery Pending Flag</i> is set for this MS: | 13 |
| 1-8-1-1-2-1 | Clear the <i>SMS Delivery Pending Flag</i> . | 14 |
| 1-8-1-1-2-2 | Execute the "HLR Initiating SMSNotification INVOKE" task (see 4.47.1). | 15 |
| 1-8-1-1-3 | ENDIF. | 16 |
| 1-8-1-2 | ELSE (SMS service is not authorized for the current system): | 17 |
| 1-8-1-2-1 | GOTO SMS Not Available. | 18 |
| 1-8-1-3 | ENDIF. | 19 |
| 1-8-2 | ELSE (AvailabilityType parameter was received): | 20 |
| 1-8-2-1 | GOTO SMS Not Available. | 21 |
| 1-8-3 | ENDIF. | 22 |
| 1-9 | ELSE (no SMS_Address parameter was received): | 23 |
| | N | 24 |
| 1-9-2 | Set the SMS status to <i>unavailable</i> . | 25 |
| 1-9-3 | Clear the temporary SMS routing address. | 26 |
| 1-9-4 | Optionally, IF the MC is to be informed of MS unavailability: | 27 |
| 1-9-4-1 | Include the SMS_AccessDeniedReason parameter set to <i>Unavailable</i> . | 28 |
| 1-9-4-2 | Execute the "HLR Initiating SMSNotification INVOKE" task (see 4.47.1). | 29 |
| 1-9-5 | ENDIF. | 30 |
| 1-10 | ENDIF. | 31 |
| 1-11 | IF an AvailabilityType parameter was received in the RegistrationNotification INVOKE: | 32 |
| 1-11-1 | Set the MS's state to <i>inactive</i> . | 33 |
| 1-12 | ELSE: | 34 |
| 1-12-1 | Set the MS's state to <i>active</i> . | 35 |
| | | 36 |
| | | 37 |
| | | 38 |
| | | 39 |
| | | 40 |
| | | 41 |
| | | 42 |
| | | 43 |
| | | 44 |
| | | 45 |
| | | 46 |
| | | 47 |
| | | 48 |
| | | 49 |
| | | 50 |
| | | 51 |
| | | 52 |
| | | 53 |
| | | 54 |
| | | 55 |
| | | 56 |
| | | 57 |
| | | 58 |
| | | 59 |
| | | 60 |

- 1-13 ENDIF.
- 2 ELSE (the received message cannot be processed or the requested information cannot be made available for the indicated MS):
- 2-1 Send a RETURN ERROR with a proper Error Code value (see the following table) to the requesting VLR.
- 3 ENDIF.
- 4 Exit this task.

Table 52 HLR RegistrationNotification Response

| Problem Detection and Recommended Response from HLR to VLR | | | | | | | | | | | |
|--|---|---|---|---|---|---|---|---|---|----|-------|
| PROBLEM DEFINITION | 1 | 2 | 3 | 4 | 5 | 6 | 7 | 8 | 9 | 10 | Notes |
| RETURN ERROR | | | | | | | | | | | |
| Error Code | | | | | | | | | | | |
| <i>UnrecognizedMIN</i> | | | | | | | | | | | a |
| <i>UnrecognizedESN</i> | | | | | | | | | | | a |
| <i>MIN/HLRMismatch</i> | | | | | | X | | | | | |
| <i>OperationSequenceProblem</i> | | | | | | | | | | | a |
| <i>ResourceShortage</i> | | X | | | | | | | | | |
| <i>OperationNotSupported</i> | X | | | | | | | | | | b |
| <i>TrunkUnavailable</i> | | | | | | | | | | | a |
| <i>ParameterError</i> | | | | X | | | | | | | d |
| <i>SystemFailure</i> | | | X | | | | | | | | |
| <i>UnrecognizedParameterValue</i> | | | | | X | | | | | | d |
| <i>FeatureInactive</i> | | | | | | | | | | | a |
| <i>MissingParameter</i> | | | | | | | X | | | | d |
| RETURN RESULT | | | | | | | | | | | c |
| AuthorizationDenied | | | | | | | | | | | |
| <i>Delinquent Account</i> | | | | | | | | | | X | |
| <i>Invalid Serial Number</i> | | | | | | | | | X | | |
| <i>Stolen Unit</i> | | | | | | | | | | X | |
| <i>Duplicate Unit</i> | | | | | | | | | | X | |
| <i>Unassigned Directory Number</i> | | | | | | | | X | | | |
| <i>Unspecified</i> | | | | | | | | | | X | |
| <i>Multiple access</i> | | | | | | | | | | X | |
| <i>Not Authorized for the MSC</i> | | | | | | | | | | X | |
| <i>Missing authentication parameters</i> | | | | | | | | | | X | |
| <i>TerminalType mismatch</i> | | | | | | | | | | X | |

Problem Detections:

1. The requested MAP operation is recognized, but not supported, by the receiving HLR, or the requesting functional entity is not authorized.
2. A required HLR resource (e.g., internal memory record, HLR is fully occupied) is temporarily not available (e.g., congestion).
3. A required resource (e.g., data base access, functional entity) is not presently accessible due to a failure. Human intervention may be required for resolution.
4. A supplied parameter has an encoding problem (e.g., the supplied MobileIdentificationNumber parameter digit values do not meet the BCD specification).
5. A supplied parameter value is unrecognized or has nonstandard values (e.g., *Not used*).
6. The supplied MobileIdentificationNumber parameter is not in the HLR's range of MINs or directory numbers (suspect routing error).

7. An expected, or required, optional parameter (e.g., PC_SSN) was not received.
8. The supplied MobileIdentificationNumber parameter is within the range of the HLR, but the MIN is not presently assigned to a subscriber.
9. The supplied MobileIdentificationNumber parameter is within the range of the HLR, but the supplied ElectronicSerialNumber parameter is not valid for the MIN's record.
10. The supplied MobileIdentificationNumber parameter is within the range of the HLR, but the MIN is either a *Delinquent Account*, *Stolen Unit*, *Duplicate Unit*, *Unspecified*, *Multiple access*, *Not Authorized for the MSC*, *Missing authentication parameters*, or *TerminalType mismatch*.

Notes:

- a. This Error Code is not an appropriate HLR response to a RegistrationNotification transaction.
- b. It is recommended that an HLR supports RegistrationNotification transactions.
- c. Only RETURN RESULT operations needing clarification have been included.
- d. Include the *Parameter Identifier* in question as the FaultyParameter parameter.

4.39 REMOTE USER INTERACTION DIRECTIVE

4.39.1 HLR Initiating a Remote User Interaction Directive

Upon request, (this request may be accepted with digits, accepted without digits, accepted though abandoned, or failed):

- 1 Send a RemoteUserInteractionDirective INVOKE message toward the MSC.
- 2 Start the timer (RUDT).
- 3 WAIT for a Remote User Interaction Directive response:
- 4 WHEN a RETURN RESULT is received:
 - 4-1 Stop the timer (RUDT).
 - 4-2 IF the message can be processed:
 - 4-2-1 IF the calling party entered digits (Digits (Dialed) parameter with one or more digits):
 - 4-2-1-1 Return to the calling task with a *successful* indication and the dialed digits.
 - 4-2-2 ELSEIF the calling party timed out (Digits (Dialed) parameter with no digits):
 - 4-2-2-1 Return to the calling task with a *successful* indication and no dialed digits.
 - 4-2-3 ELSEIF the calling party abandoned the call (no Digits (Dialed) parameter):
 - 4-2-3-1 Return to the calling task with a *abandoned* indication.
 - 4-2-4 ENDIF.
 - 4-3 ELSE (the message cannot be processed):
 - 4-3-1 Return to the calling task with a *failure* indication.
 - 4-4 ENDIF.
 - 5 WHEN a RETURN ERROR or REJECT is received:
 - 5-1 Stop the timer (RUDT).
 - 5-2 Return to the calling task with a *failure* indication.
 - 6 WHEN the timer (RUDT) expires:

- 1 6-1 Return to the calling task with a *failure* indication.
 2
 3 7 ENDWAIT.
 4

5 4.39.2 MSC Remote User Interaction

7 Upon request, (usually after receiving a RemoteUserInteractionDirection), the MSC shall
 8 do the following:
 9

10 1 IF the call has not been abandoned:

11 1-1 Unload the DigitCollectionControl parameter overwriting the default control
 12 parameters.
 13

14 1-2 Optionally store any received digits in the digit buffer.
 15

16 1-3 Start the maximum interaction timer.

 (The maximum interaction timer is running.)

17 1-4 IF type ahead is not allowed:

18 1-4-1 Clear the digit buffer.
 19

20 1-5 IF break-in is allowed:

21 1-5-1 Begin playing the prompting announcement(s) as indicated by the
 22 AnnouncementList.
 23

24 1-5-2 WAIT for the end of the announcement:
 25

26 1-5-3 WHEN a digit is received:

27 1-5-3-1 Stop the announcement.
 28

29 1-5-3-2 Execute the “MSC Receiving a User Interaction Digit” task (see 4.39.3).
 30 (Process each digit individually, even if entered en bloc.).
 31

32 1-5-3-3 IF the request was accepted:

33 1-5-3-3-1 IF special interdigit timing is required:

34 1-5-3-3-1-1 Start the interdigit timer with the Special Interdigit Time.
 35

36 1-5-3-3-2 ELSE:

37 1-5-3-3-2-1 Start the interdigit timer with the Normal Interdigit Time.
 38

39 1-5-3-3-3 ENDIF.

40 1-5-3-3-4 GOTO Collect Digit.
 41

42 1-5-3-4 ELSEIF the request was entered:

43 1-5-3-4-1 Stop the maximum interaction timer.
 44

45 1-5-3-4-2 Include the Digits (Dialed) parameter set to the digits in the digit
 46 buffer, including none (no digits is not a zero length or null
 47 parameter).
 48

49 1-5-3-4-3 Send a RETURN RESULT.
 50

51 1-5-3-4-4 Exit this task.
 52

53 1-5-3-5 ELSEIF the request was cleared:

54 1-5-3-5-1 GOTO Play Prompt. .
 55

56 1-5-3-6 ELSE (the request was ignored):

57 1-5-3-6-1 Remain in this state to wait for the end of the announcement.
 58

59 1-5-3-7 ENDIF.
 60

 1-5-4 WHEN the announcement ends:

| | | |
|-----------|---|----|
| 1-5-4-1 | Start the interdigit timer with the Initial Interdigit Timer value. | 1 |
| 1-5-5 | WHEN the caller abandons the call: | 2 |
| 1-5-5-1 | Stop the maximum interaction timer. | 3 |
| | (Do not include the Digits (Dialed) parameter.) | 4 |
| 1-5-5-2 | Send a RETURN RESULT. | 5 |
| 1-5-5-3 | Exit this task. | 6 |
| 1-5-6 | WHEN the maximum interaction timer expires: | 7 |
| 1-5-6-1 | Include the Digits (Dialed) parameter set to the digits in the digit buffer, including none (no digits is not a zero length or null parameter). | 8 |
| 1-5-6-2 | Send a RETURN RESULT. | 9 |
| 1-5-6-3 | Exit this task. | 10 |
| 1-5-7 | ENDWAIT. | 11 |
| 1-6 | ELSE (break-in is not allowed): | 12 |
| 1-6-1 | Start playing the prompting announcement(s) as indicated by the AnnouncementList. | 13 |
| 1-6-2 | WAIT for the end of the announcement: | 14 |
| 1-6-3 | WHEN a digit is received: | 15 |
| 1-6-3-1 | Remain in this state. | 16 |
| 1-6-4 | WHEN the announcement ends: | 17 |
| 1-6-4-1 | Start the interdigit timer with the Initial Interdigit Timer value. | 18 |
| 1-6-5 | WHEN the caller abandons the call: | 19 |
| 1-6-5-1 | Stop the maximum interaction timer. | 20 |
| | (Do not include the Digits (Dialed) parameter.) | 21 |
| 1-6-5-2 | Send a RETURN RESULT. | 22 |
| 1-6-5-3 | Exit this task. | 23 |
| 1-6-6 | WHEN the maximum interaction timer expires: | 24 |
| 1-6-6-1 | Include the Digits (Dialed) parameter set to the digits in the digit buffer, including none (no digits is not a zero length or null parameter). | 25 |
| 1-6-6-2 | Send a RETURN RESULT. | 26 |
| 1-6-6-3 | Exit this task. | 27 |
| 1-6-7 | ENDWAIT. | 28 |
| 1-6-8 | Clear the digit buffer. | 29 |
| 1-7 | ENDIF. | 30 |
| | (An interdigit timer and the maximum interaction timer are running.) | 31 |
| 1-8 | WAIT to receive a digit. | 32 |
| 1-9 | WHEN a digit is received: | 33 |
| 1-9-1 | Execute the “MSC Receiving a User Interaction Digit” task (see 4.39.3). (Process each digit individually, even if entered en bloc.) | 34 |
| 1-9-2 | IF the request was accepted: | 35 |
| 1-9-2-1 | Stop the interdigit timer. | 36 |
| 1-9-2-2 | IF the Interdigit Gap is special: | 37 |
| 1-9-2-2-1 | Start the interdigit timer with the Special Interdigit Time. | 38 |
| | | 39 |
| | | 40 |
| | | 41 |
| | | 42 |
| | | 43 |
| | | 44 |
| | | 45 |
| | | 46 |
| | | 47 |
| | | 48 |
| | | 49 |
| | | 50 |
| | | 51 |
| | | 52 |
| | | 53 |
| | | 54 |
| | | 55 |
| | | 56 |
| | | 57 |
| | | 58 |
| | | 59 |
| | | 60 |

1
2
3
4
5
6
7
8
9
10
11
12
13
14
15
16
17
18
19
20
21
22
23
24
25
26
27
28
29
30
31
32
33
34
35
36
37
38
39
40
41
42
43
44
45
46
47
48
49
50
51
52
53
54
55
56
57
58
59
60

```

1-9-2-3      ELSE:
1-9-2-3-1    Start the interdigit timer  with the Normal Interdigit Time.
1-9-2-4      ENDIF.
1-9-2-5      Remain in this state.
1-9-3        ELSEIF the request was entered:
1-9-3-1      Stop the interdigit timer.
1-9-3-2      Stop the maximum interaction timer. .
1-9-3-3      Include the Digits (Dialed)  parameter set to the digits in the digit buffer,
              including none (no digits is not a zero length or null parameter).
1-9-3-4      Send a RETURN RESULT.
1-9-4        ELSEIF the request was cleared:
1-9-4-1      Stop the interdigit timer.
1-9-4-2      GOTO Play Prompt.
1-9-5        ELSE (the request was ignored):
1-9-5-1      Remain in this state.
1-9-6        ENDIF.
1-10        WHEN the interdigit timer  expires:
1-10-1      Stop the maximum interaction timer.
1-10-2      Include the Digits (Dialed)  parameter set to the digits in the digit buffer,
              including none (no digits is not a zero length or null parameter).
1-10-3      Send a RETURN RESULT.
1-11        WHEN the caller abandons the call:
1-11-1      Stop the interdigit timer.
1-11-2      Stop the maximum interaction timer.
              (Do not include the Digits (Dialed)  parameter.)
1-11-3      Send a RETURN RESULT.
1-12        WHEN the maximum interaction timer  expires:
1-12-1      Stop the interdigit timer.
1-12-2      Include the Digits (Dialed)  parameter set to the digits in the digit buffer,
              including none (no digits is not a zero length or null parameter).
1-12-3      Send a RETURN RESULT.
1-13        ENDWAIT.
2  ELSE (the call has been abandoned):
      (Do not include the Digits (Dialed)  parameter.)
2-1      Send a RETURN RESULT.
3  ENDIF.
4  Exit this task.

```

Table 53 MSC RemoteUserInteractionDirective Response

| Problem Detection and Recommended Response
from MSC to HLR | | | | | | |
|---|---|---|---|---|---|-------|
| PROBLEM DEFINITION | 1 | 2 | 3 | 4 | 5 | Notes |
| RETURN ERROR
Error Code | | | | | | |
| <i>UnrecognizedMIN</i> | | | | | | a |
| <i>UnrecognizedESN</i> | | | | | | a |
| <i>MIN/HLRMismatch</i> | | | | | | a |
| <i>OperationSequenceProblem</i> | | | | | X | |
| <i>ResourceShortage</i> | | X | | | | |
| <i>OperationNotSupported</i> | X | | | | | b |
| <i>TrunkUnavailable</i> | | | | | | a |
| <i>ParameterError</i> | | | | | | a |
| <i>SystemFailure</i> | | | X | | | |
| <i>UnrecognizedParameterValue</i> | | | | X | | |
| <i>FeatureInactive</i> | | | | | | a |
| <i>MissingParameter</i> | | | | | | a |
| RETURN RESULT | | | | | | c |

Problem Detections:

1. The requested MAP operation is recognized, but not supported, by the receiving MSC, or the requesting functional entity is not authorized.
2. A required MSC resource (e.g., internal memory record, MSC is fully occupied) is temporarily not available (e.g., congestion).
3. A required resource (e.g., data base access, functional entity) is not presently accessible due to a failure. Human intervention may be required for resolution.
4. A supplied parameter value is not supported or has a reserved value (e.g., provide an empty RETURN RESULT).
5. The received transaction cannot be correlated with a call.

Notes:

- a. This Error Code is not an appropriate MSC response to a RemoteUserInteractionDirective transaction.
- b. It is recommended that an MSC supports RemoteUserInteractionDirective transactions.
- c. Only RETURN RESULT operations needing clarification have been included.

4.39.3 MSC Receiving a User Interaction Digit

Upon request, the MSC shall do the following analysis on a single digit:

- 1 IF the received digit is a Clear Digit:
 - 1-1 Clear the digit buffer.
 - 1-2 Return to the calling task with a *cleared* indication.
- 2 ELSEIF the received digit is an Allowed Digit:
 - 2-1 Store the received digit in the digit buffer.
 - 2-2 IF the maximum number of digits to collect have been collected:
 - 2-2-1 Return to the calling task with an *entered* indication.
 - 2-3 ELSEIF the received digit is an Enter Digit:

- 1 2-3-1 IF the minimum number of digits have been collected:
 2 2-3-1-1 Return to the calling task with an *entered* indication.
 3 2-3-2 ELSE (not enough digits have been collected):
 4 2-3-2-1 Clear the digit buffer.
 5 2-3-2-2 Return to the calling task with a *cleared* indication.
 6 2-3-3 ENDIF.
 7 2-4 ELSE:
 8 2-4-1 Return to the calling task with an *accepted* indication.
 9 2-5 ENDIF.
 10 3 ELSE the received digit is not an Allowed Digit:
 11 3-1 Return to the calling task with an *ignored* indication.
 12 4 ENDIF.
 13 5 Return to the calling task with an *accepted* indication.
 14
 15
 16
 17
 18
 19
 20

21 4.40 RESET CIRCUIT

22 See Chapter 4 for the Reset Circuit procedures.
 23
 24
 25

26 4.41 ROUTING REQUEST

27 4.41.1 HLR Initiating a Routing Request

28 When an HLR requires a temporary routing address to a termination, such as, an MS, a mail
 29 box on a voice mail system, an interaction dialog, or other voice resource, it shall perform
 30 the following (termination specific parameter should already be included):
 31

- 32 1 Relay the received BillingID parameter to identify the call on the Originating MSC.
 33 2 Include the called MobileIdentificationNumber parameter set to identify the called (or
 34 3 Include the called ElectronicSerialNumber parameter set to identify the called (or
 35 4 Relay the received MSCID parameter to identify the Originating MSC.
 36 5 Relay the received SystemMyTypeCode parameter to identify the manufacturer of the
 37 6 IF the PC_SSN parameter is received:
 38 6-1 Relay the received PC_SSN parameter to address the Originating MSC.
 39 7 ENDIF.
 40 8 IF the MSCIdentificationNumber parameter is received:
 41 8-1 Relay the received MSCIdentificationNumber parameter to address the
 42 9 ENDIF.
 43 10 IF the call is to a mobile directory number that is not the MobileIdentificationNumber:
 44 10-1 Include MobileDirectoryNumber parameter.
 45
 46
 47
 48
 49
 50
 51
 52
 53
 54
 55
 56
 57
 58
 59
 60

- 11 ENDIF. 1
- 12 IF subscriber services are modified for this call: 2
- 12-1 Include OneTimeFeatureIndicator parameter set for this particular call. 3
- 13 ENDIF. 4
- 14 Include SenderIdentificationNumber parameter set to the HLR's identification 5
number. 6
- 15 Execute the "HLR CNIP Terminating Call Invocation" task (see 5.8.1). 7
- 16 Send a RoutingRequest INVOKE to the VLR (or other system) with which the MS is 8
currently registered. 9
- 17 Start the Routing Request Timer (RRT). 10
- 18 WAIT for a Routing Request response. 11
- 19 WHEN a RETURN RESULT is received: 12
- 19-1 Stop timer (RRT). 13
- 19-2 IF the message cannot be processed: 14
- 19-2-1 Execute "Local Recovery Procedures" task (see 3.5.1). 15
- 19-2-2 Include the AccessDeniedReason parameter set to *Termination Denied*. 16
- 19-3 ENDIF. 17
- 20 WHEN a RETURN ERROR or REJECT is received: 18
- 20-1 Stop timer (RRT). 19
- 20-2 Execute "Local Recovery Procedures " task (see 3.5.1). 20
- 20-3 Include the AccessDeniedReason parameter set to *Termination Denied*. 21
- 20-4 IF the Error Code indicates *UnrecognizedMIN* OR IF the Error Code indicates 22
OperationNotSupported: 23
- 20-4-1 Clear the HLR's pointer to the VLR serving the MS. 24
- 20-5 ENDIF. 25
- 21 WHEN timer (RRT) expires: 26
- 21-1 Execute "Local Recovery Procedures " task (see 3.5.1). 27
- 21-2 Include the AccessDeniedReason parameter set to *Termination Denied*. 28
- 22 ENDWAIT. 29
- 23 Return to the calling task. 30

4.41.2 VLR Receiving RoutingRequest INVOKE

When a VLR receives a RoutingRequest INVOKE, it shall perform the following:

- 1 IF the received message can be processed: 31
- 1-1 IF the indicated MS is in the *active* state: 32
- 1-1-1 Relay all received parameters. 33
- 1-1-2 IF the OneTimeFeatureIndicator parameter is not received: 34
- 1-1-2-1 Execute the "Initialize the OneTimeFeatureIndicator Parameter" task (see 35
3.2.8). 36
- 1-1-2-2 Include the OneTimeFeatureIndicator parameter. 37
- 1-1-3 ENDIF. 38

1 1-1-4 IF the request is for a mobile termination (i.e., no TerminationTreatment
2 parameter is received or a TerminationTreatment is received with a value of
3 *MSTermination*) AND IF the LocationAreaID parameter is known:
4
5 1-1-4-1 Include the LocationAreaID parameter.
6
7 1-1-5 ENDIF.
8
9 1-1-6 Send a RoutingRequest INVOKE to the MSC that is currently serving the
10 indicated MS.
11
12 1-1-7 Start the Routing Request Timer (RRT).
13
14 1-1-8 WAIT for a Routing Request Response:
15
16 1-1-9 WHEN a RETURN RESULT is received:
17
18 1-1-9-1 Stop timer (RRT).
19
20 1-1-9-2 IF the message is valid:
21
22 1-1-9-2-1 Relay all received parameters.
23
24 1-1-9-2-2 IF the AccessDeniedReason parameter is received:
25
26 1-1-9-2-2-1 IF the AccessDeniedReason parameter indicates :
27
28 1-1-9-2-2-1-1 The VLR shall set the state to *inactive*.
29
30 1-1-9-2-2-2 ENDIF.
31
32 1-1-9-2-3 ENDIF.
33
34 1-1-9-2-4 Send a RETURN RESULT to the HLR.
35
36 1-1-9-3 ELSE:
37
38 1-1-9-3-1 Send a RETURN ERROR with Error Code *SystemFailure* to the
39 HLR.
40
41 1-1-9-3-2 Execute "Local Recovery Procedures" task (see 3.5.1).
42
43 1-1-9-4 ENDIF.
44
45 1-1-10 WHEN a RETURN ERROR or REJECT is received:
46
47 1-1-10-1 Stop timer (RRT).
48
49 1-1-10-2 CASE Error Code OF:
50
51 1-1-10-3 *ParameterError*:
52
53 1-1-10-3-1 IF the parameter was originated from the initiating functional entity:
54
55 1-1-10-3-1-1 Send a RETURN ERROR with Error Code *ParameterError*.
56
57 1-1-10-3-2 ELSE:
58
59 1-1-10-3-2-1 Send a RETURN ERROR with Error Code *SystemFailure*.
60
61 1-1-10-3-3 ENDIF.
62
63 1-1-10-4 *OperationSequenceProblem*:
64
65 1-1-10-4-1 Send a RETURN ERROR with Error Code
66 *OperationSequenceProblem*.
67
68 1-1-10-5 *DEFAULT*:
69
70 1-1-10-5-1 Send a RETURN ERROR with Error Code *SystemFailure*.
71
72 1-1-10-5-2 Execute "Local Recovery Procedures" task (see 3.5.1).
73
74 1-1-10-6 ENDCASE.
75
76 1-1-11 WHEN timer (RRT) expires:
77
78 1-1-11-1 Send a RETURN ERROR with Error Code *SystemFailure* to the HLR.

- 1-1-11-2 Execute “Local Recovery Procedures ” task (see 3.5.1).
- 1-1-12 ENDWAIT.
- 1-2 ELSE (the indicated MS is in the *inactive* state):
 - 1-2-1 Include the AccessDeniedReason parameter set to *Inactive*.
 - 1-2-2 Include the MSCID parameter set to the identity of the Serving MSC.
 - 1-2-3 Send a RETURN RESULT to the HLR.
- 1-3 ENDIF.
- 2 ELSE (the received message cannot be processed):
 - 2-1 Send a RETURN ERROR with a proper Error Code value (see the following table) to the HLR.
- 3 ENDIF.
- 4 Exit this task.

Table 54 VLR RoutingRequest Response

| Problem Detection and Recommended Response from VLR to HLR | | | | | | | | | | | | | |
|--|---|---|---|---|---|---|---|---|---|----|----|----|-------|
| PROBLEM DEFINITION | 1 | 2 | 3 | 4 | 5 | 6 | 7 | 8 | 9 | 10 | 11 | 12 | Notes |
| RETURN ERROR
Error Code | | | | | | | | | | | | | |
| <i>UnrecognizedMIN</i> | | | | | | | X | | | | | | e |
| <i>UnrecognizedESN</i> | | | | | | | | X | | | | | |
| <i>MIN/HLRMismatch</i> | | | | | | | | | | | | | a |
| <i>OperationSequenceProblem</i> | | | | | | | | | | | | | a |
| <i>ResourceShortage</i> | | X | | | | | | | | | | | |
| <i>OperationNotSupported</i> | X | | | | | | | | | | | | b |
| <i>TrunkUnavailable</i> | | | | | | | | | | | | | a |
| <i>ParameterError</i> | | | | X | | | | | | | | | d |
| <i>SystemFailure</i> | | | X | | | | | | | | | | |
| <i>UnrecognizedParameterValue</i> | | | | | X | | | | | | | | d |
| <i>FeatureInactive</i> | | | | | | | | | | | | | a |
| <i>MissingParameter</i> | | | | | | X | | | | | | | d |
| RETURN RESULT
AccessDeniedReason | | | | | | | | | | | | | c, f |
| <i>Unassigned directory number</i> | | | | | | | | | | | | | g |
| <i>Inactive</i> | | | | | | | | | X | | | | |
| <i>Busy</i> | | | | | | | | | | X | | | |
| <i>Termination Denied</i> | | | | | | | | | | | | | g |
| <i>No Page Response</i> | | | | | | | | | | | X | | |
| <i>Unavailable</i> | | | | | | | | | | | | X | |

Problem Detections:

1. The requested MAP operation is recognized, but not supported, by the receiving VLR, or the requesting functional entity is not authorized.
2. A required VLR resource (e.g., internal memory record, VLR is fully occupied) is temporarily not available (e.g., congestion).
3. A required resource (e.g., data base access, functional entity) is not presently accessible due to a failure. Human intervention may be required for resolution.
4. A supplied parameter has an encoding problem (e.g., the supplied MobileIdentificationNumber parameter digit values do not meet the BCD specification).

1
2
3
4
5
6
7
8
9
10
11
12
13
14
15
16
17
18
19
20
21
22
23
24
25
26
27
28
29
30
31
32
33
34
35
36
37
38
39
40
41
42
43
44
45
46
47
48
49
50
51
52
53
54
55
56
57
58
59
60

5. A supplied parameter value is unrecognized or has nonstandard values (e.g., *Not used*).
6. An expected, or required, optional parameter (e.g., PC_SSN) was not received.
7. A VLR record does not presently exist for the supplied MobileIdentificationNumber parameter.
8. A VLR record exists for the supplied MobileIdentificationNumber parameter, but the supplied ElectronicSerialNumber parameter does not match the ESN in the VLR record.
9. A VLR record exists for the supplied MobileIdentificationNumber parameter, but the MIN's status is *inactive* (powered down, failed to autonomously register). QualificationDirective profile updates to the VLR may continue and RoutingRequests may be suppressed until re-registration occurs.
10. A VLR record exists for the supplied MobileIdentificationNumber parameter, but the MIN's status is *Busy*.
11. A VLR record may exist for the supplied MobileIdentificationNumber parameter, but the MIN did not respond to an attempted page.
12. A VLR record exists for the supplied MobileIdentificationNumber parameter, but the MIN's status is *Unavailable* (e.g., powered down, failure to autonomously register). QualificationDirective profile updates and RoutingRequests to the VLR shall continue.

Notes:

- a. This Error Code is not an appropriate VLR response to a RoutingRequest transaction.
- b. It is recommended that a VLR support RoutingRequest transactions.
- c. Only RETURN RESULT operations needing clarification have been included.
- d. Include the *Parameter Identifier* in question as the FaultyParameter parameter.
- e. A page of the MS was not attempted.
- f. A VLR record exists for the supplied MobileIdentificationNumber parameter, but the MIN's status is *Termination denied* or *Invalid*. The VLR shall appropriately attempt to deliver the call.
- g. This AccessDeniedReason is not an appropriate VLR response to a RoutingRequest transaction.

4.41.3 MSC Receiving RoutingRequest INVOKE

When an MSC receives a RoutingRequest INVOKE, it shall perform the following:

- 1 IF the received message can be processed:
 - 1-1 IF the TerminationTreatment parameter is received:
 - 1-1-1 Set the termination treatment to the received TerminationTreatment parameter.
 - 1-2 ELSE:
 - 1-2-1 Set the termination treatment to *MS termination* (the default treatment).
 - 1-3 ENDIF.
 - 1-4 IF the termination treatment indicates an *MS termination*:
 - 1-4-1 IF the MS is inactive:
 - 1-4-1-1 Include the AccessDeniedReason parameter set to *Inactive*.
 - 1-4-1-2 Include the MSCID parameter set to the identity of the MSC.
 - 1-4-1-3 IF a TLDN should be returned:
 - 1-4-1-3-1 (Fall through to select a TLDN.)
 - 1-4-1-4 ELSE:
 - 1-4-1-4-1 Send a RETURN RESULT to the requesting VLR.
 - 1-4-1-4-2 Exit this task.
 - 1-4-1-5 ENDIF.

| | | |
|---------------|--|----|
| 1-4-2 | ELSEIF the MS is not available: | 1 |
| 1-4-2-1 | Include the AccessDeniedReason parameter set to <i>Unavailable</i> . | 2 |
| 1-4-2-2 | Include the MSCID parameter set to the identity of the MSC. | 3 |
| 1-4-2-3 | IF a TLDN should be returned: | 4 |
| 1-4-2-3-1 | (Fall through to select a TLDN.) | 5 |
| 1-4-2-4 | ELSE: | 6 |
| 1-4-2-4-1 | Send a RETURN RESULT to the requesting VLR. | 7 |
| 1-4-2-4-2 | Exit this task. | 8 |
| 1-4-2-5 | ENDIF. | 9 |
| 1-4-3 | ENDIF. | 10 |
| 1-4-4 | IF the MSC does not have the MS's service profile information. | 11 |
| 1-4-4-1 | Optionally execute the "MSC Initiating a Qualification Request" task (see 4.33.1). | 12 |
| 1-4-5 | ENDIF. | 13 |
| 1-4-6 | IF the MS is not <i>busy</i> : ¹ | 14 |
| 1-4-6-1 | IF pre-routing call paging is to be performed: | 15 |
| 1-4-6-1-1 | Execute the "Page an MS Procedure" (see 3.3.3). | 16 |
| 1-4-6-1-2 | IF the paging was successful on a bordering system. | 17 |
| 1-4-6-1-2-1 | Relay all parameters received via the InterSystemPage RETURN RESULT or UnsolicitedResponse INVOKE. | 18 |
| 1-4-6-1-2-2 | Send a RETURN RESULT to the requesting VLR. | 19 |
| 1-4-6-1-2-3 | Exit this task. | 20 |
| 1-4-6-1-3 | ELSEIF the paging was locally successful. | 21 |
| 1-4-6-1-3-1 | (Fall through to select a TLDN.) | 22 |
| 1-4-6-1-4 | ELSE (the paging was unsuccessful): | 23 |
| 1-4-6-1-4-1 | Relay the indicated AccessDeniedReason parameter. | 24 |
| 1-4-6-1-4-2 | IF a TLDN should be returned: | 25 |
| 1-4-6-1-4-2-1 | (Fall through to select a TLDN.) | 26 |
| 1-4-6-1-4-3 | ELSE: | 27 |
| 1-4-6-1-4-3-1 | Send a RETURN RESULT to the requesting VLR. | 28 |
| 1-4-6-1-4-3-2 | Exit this task. | 29 |
| 1-4-6-1-4-4 | ENDIF. | 30 |
| 1-4-6-1-5 | ENDIF. | 31 |
| 1-4-6-2 | ELSE (no pre-routing paging): | 32 |
| 1-4-6-2-1 | (Fall through to select a TLDN.) | 33 |
| 1-4-6-3 | ENDIF. | 34 |

¹MS busy or call pending can be defined as either a) actual calls in the MSC or b) a combination of actual calls in the MSC or TLDNs assigned. Choice b) uses less of the call redirection procedures and thereby routes calls faster. Choice a) better handles abandoned calls.

1
2
3
4
5
6
7
8
9
10
11
12
13
14
15
16
17
18
19
20
21
22
23
24
25
26
27
28
29
30
31
32
33
34
35
36
37
38
39
40
41
42
43
44
45
46
47
48
49
50
51
52
53
54
55
56
57
58
59
60

```

1-4-7      ELSE (the MS is busy)2:
1-4-7-1    IF there is another call pending (for the Call Waiting feature) or the call
            is not in a two-way talking state (e.g., PACA requested, alerting,
            awaiting answer, awaiting page response, CC invoked, 3WC invoked,
            CT invoked):
1-4-7-1-1  Include the AccessDeniedReason parameter set to Busy.
1-4-7-1-2  Include the MSCID parameter set to the identity of the MSC.
1-4-7-1-3  IF a TLDN should be returned:
1-4-7-1-3-1      (Fall through to select a TLDN.)
1-4-7-1-4  ELSE:
1-4-7-1-4-1      Send a RETURN RESULT to the requesting VLR.
1-4-7-1-4-2      Exit this task.
1-4-7-1-5  ENDIF.
1-4-7-2    ELSE (Call Waiting is possible):
1-4-7-2-1  IF the OneTimeFeatureIndicator is received for the incoming call:
1-4-7-2-1-1      IF the Call Waiting for Incoming Call of the
                    OneTimeFeatureIndicator is set to ignore:
1-4-7-2-1-1-1    Set the incoming call waiting type equal to Normal CW.
1-4-7-2-1-2    ELSE:
1-4-7-2-1-2-1    Set the incoming call waiting type to the Call Waiting for
                    Incoming Call field of the received
                    OneTimeFeatureIndicator. .
1-4-7-2-1-3    ENDIF.
1-4-7-2-2  ELSE (the OneTimeFeatureIndicator parameter was not received):
1-4-7-2-2-1    Set the incoming call waiting type equal to Normal CW.
1-4-7-2-3  ENDIF.
1-4-7-2-4  CASE incoming call waiting type OF:
1-4-7-2-5  No CW:
1-4-7-2-5-1    Include the AccessDeniedReason parameter set to Busy.
1-4-7-2-5-2    Include the MSCID parameter set to the identity of the MSC.
1-4-7-2-5-3    IF a TLDN should be returned:
1-4-7-2-5-3-1      (Fall through to select a TLDN.)
1-4-7-2-5-4    ELSE:
1-4-7-2-5-4-1      Send a RETURN RESULT to the requesting VLR.
1-4-7-2-5-4-2      Exit this task.
1-4-7-2-5-5    ENDIF.
1-4-7-2-5-6    Return to the calling task with a Busy indication.

```

²MS busy or call pending can be defined as either a) actual calls in the MSC or b) a combination of actual calls in the MSC or TLDNs assigned. Choice b) uses less of the call redirection procedures and thereby routes calls faster. Choice a) better handles abandoned calls.

| | | |
|-----------------|--|----|
| 1-4-7-2-6 | <i>Normal CW:</i> | 1 |
| 1-4-7-2-6-1 | IF the existing call has <i>Normal CW</i> : | 2 |
| 1-4-7-2-6-1-1 | IF the TerminationTreatment parameter is received: | 3 |
| 1-4-7-2-6-1-1-1 | Include the ConditionallyDeniedReason parameter set to <i>Waitable</i> . | 4 |
| | | 5 |
| | | 6 |
| 1-4-7-2-6-1-2 | ENDIF. | 7 |
| 1-4-7-2-6-1-3 | (Fall through to select a TLDN.) | 8 |
| | | 9 |
| 1-4-7-2-6-2 | ELSE: | 10 |
| 1-4-7-2-6-2-1 | Include the AccessDeniedReason parameter set to <i>Busy</i> . | 11 |
| 1-4-7-2-6-2-2 | Include the MSCID parameter set to the identity of the MSC. | 12 |
| | | 13 |
| | | 14 |
| 1-4-7-2-6-2-3 | IF a TLDN should be returned: | 15 |
| 1-4-7-2-6-2-3-1 | (Fall through to select a TLDN.) | 16 |
| | | 17 |
| 1-4-7-2-6-2-4 | ELSE: | 18 |
| 1-4-7-2-6-2-4-1 | Send a RETURN RESULT to the requesting VLR. | 19 |
| 1-4-7-2-6-2-4-2 | Exit this task. | 20 |
| | | 21 |
| 1-4-7-2-6-2-5 | ENDIF. | 22 |
| | | 23 |
| 1-4-7-2-6-3 | ENDIF. | 24 |
| | | 25 |
| 1-4-7-2-7 | <i>Priority CW:</i> | 26 |
| 1-4-7-2-7-1 | IF the existing call has Call Waiting field set to <i>Normal CW</i> or <i>Priority CW</i> : | 27 |
| | | 28 |
| 1-4-7-2-7-1-1 | IF the TerminationTreatment parameter is received (the false sense of this test is also for backward compatibility): | 29 |
| | | 30 |
| 1-4-7-2-7-1-1-1 | Include the ConditionallyDeniedReason parameter set to <i>Waitable</i> . | 31 |
| | | 32 |
| | | 33 |
| 1-4-7-2-7-1-2 | ENDIF. | 34 |
| 1-4-7-2-7-1-3 | (Fall through to select a TLDN.) | 35 |
| | | 36 |
| 1-4-7-2-7-2 | ELSE: | 37 |
| 1-4-7-2-7-2-1 | Include the AccessDeniedReason parameter set to <i>Busy</i> . | 38 |
| 1-4-7-2-7-2-2 | Include the MSCID parameter set to the identity of the MSC. | 39 |
| | | 40 |
| | | 41 |
| 1-4-7-2-7-2-3 | IF a TLDN should be returned: | 42 |
| 1-4-7-2-7-2-3-1 | (Fall through to select a TLDN.) | 43 |
| | | 44 |
| 1-4-7-2-7-2-4 | ELSE: | 45 |
| 1-4-7-2-7-2-4-1 | Send a RETURN RESULT to the requesting VLR. | 46 |
| 1-4-7-2-7-2-4-2 | Exit this task. | 47 |
| | | 48 |
| 1-4-7-2-7-2-5 | ENDIF. | 49 |
| | | 50 |
| 1-4-7-2-7-3 | ENDIF. | 51 |
| | | 52 |
| 1-4-7-2-8 | ENDCASE. | 53 |
| | | 54 |
| 1-4-7-3 | ENDIF. | 55 |
| | | 56 |
| 1-4-8 | ENDIF. | 57 |
| | | 58 |
| 1-5 | ENDIF. | 59 |
| | | 60 |

1
2
3
4
5
6
7
8
9
10
11
12
13
14
15
16
17
18
19
20
21
22
23
24
25
26
27
28
29
30
31
32
33
34
35
36
37
38
39
40
41
42
43
44
45
46
47
48
49
50
51
52
53
54
55
56
57
58
59
60

T N

- 1-6 IF TLDN is available:
 - 1-6-1 CASE termination treatment OF:
 - 1-6-2 *MSTermination:*
 - 1-6-2-1 Store the MobileIdentificationNumber parameter of the MS to page.
 - 1-6-2-2 Store the ElectronicSerialNumber parameter of the MS to page.
 - 1-6-2-3 IF the TerminationTriggers parameter is received:
 - 1-6-2-3-1 Store the TerminationTriggers parameter.
 - 1-6-2-4 ENDIF.
 - 1-6-2-5 IF the LegInformation parameter is received:
 - 1-6-2-5-1 Store the LegInformation parameter.
 - 1-6-2-6 ENDIF.
 - 1-6-2-7 IF the GroupInformation parameter is received:
 - 1-6-2-7-1 Store the GroupInformation parameter.
 - 1-6-2-8 ENDIF.
 - 1-6-2-9 IF the MobileDirectoryNumber parameter is received:
 - 1-6-2-9-1 Store the MobileDirectoryNumber parameter.
 - 1-6-2-10 ENDIF.
 - 1-6-2-11 IF the AlertCode parameter is received:
 - 1-6-2-11-1 Store the AlertCode parameter.
 - 1-6-2-12 ENDIF.
 - 1-6-2-13 Execute the “MSC Record the DMH Parameters” task (see3.3.7).
 - 1-6-2-14 Assign a TLDN to the indicated MS.
 - 1-6-3 *VoiceMailDelivery:* :
 - 1-6-3-1 IF the Digits (Destination) parameter is received:
 - 1-6-3-1-1 Store the received Digits (Destination) parameter as the voice mail system identifier.
 - 1-6-3-2 ELSE:
 - 1-6-3-2-1 Store a default voice mail system identifier.
 - 1-6-3-3 ENDIF.
 - 1-6-3-4 IF the VoiceMailboxNumber parameter is received:
 - 1-6-3-4-1 Store the VoiceMailboxNumber as the voice mail box number.
 - 1-6-3-5 ELSE:
 - 1-6-3-5-1 Store the MS’s MobileIdentificationNumber as the voice mail box number.
 - 1-6-3-6 ENDIF.
 - 1-6-3-7 IF the VoiceMailboxPIN parameter is received:
 - 1-6-3-7-1 Store the VoiceMailboxPIN as the voice mail PIN.
 - 1-6-3-8 ENDIF.
 - 1-6-3-9 Assign a TLDN for the indicated voice mail delivery.
 - 1-6-4 *VoiceMailRetrieval:*

| | | |
|-----------|---|----|
| 1-6-4-1 | IF the Digits (Destination) parameter is received: | 1 |
| 1-6-4-1-1 | Store the received Digits (Destination) parameter as the voice mail system identifier. | 2 |
| | | 3 |
| | | 4 |
| 1-6-4-2 | ELSE: | 5 |
| 1-6-4-2-1 | Store a default voice mail system identifier. | 6 |
| | | 7 |
| 1-6-4-3 | ENDIF. | 8 |
| 1-6-4-4 | IF the VoiceMailboxNumber parameter is received: | 9 |
| 1-6-4-4-1 | Store the VoiceMailboxNumber as the voice mail box number. | 10 |
| | | 11 |
| 1-6-4-5 | ELSE: | 12 |
| 1-6-4-5-1 | Store the MS's MobileIdentificationNumber as the voice mail box number. | 13 |
| | | 14 |
| | | 15 |
| 1-6-4-6 | ENDIF. | 16 |
| 1-6-4-7 | IF the VoiceMailboxPIN parameter is received: | 17 |
| 1-6-4-7-1 | Store the VoiceMailboxPIN as the voice mail PIN. | 18 |
| | | 19 |
| 1-6-4-8 | ENDIF. | 20 |
| | | 21 |
| 1-6-4-9 | Assign a TLDN for the indicated voice mail retrieval. | 22 |
| 1-6-5 | <i>DialogTermination:</i> | 23 |
| 1-6-5-1 | IF a DestinationDigits parameter was received: | 24 |
| 1-6-5-1-1 | Store the received DestinationDigits parameter as the dialog identification. | 25 |
| | | 26 |
| | | 27 |
| 1-6-5-1-2 | Store the MobileIdentificationNumber and ElectronicSerialNumber for subsequent interactions. | 28 |
| | | 29 |
| | | 30 |
| 1-6-5-1-3 | Assign a TLDN for the indicated dialog. | 31 |
| | | 32 |
| 1-6-5-2 | ELSE: | 33 |
| 1-6-5-2-1 | Send a RETURN ERROR with an Error Code <i>MissingParameter</i> . | 34 |
| | | 35 |
| 1-6-5-3 | ENDIF. | 36 |
| 1-6-6 | <i>DEFAULT:</i> | 37 |
| 1-6-6-1 | Send a RETURN ERROR with an Error Code <i>UnrecognizedParameterValue</i> . | 38 |
| | | 39 |
| | | 40 |
| 1-6-7 | ENDCASE. | 41 |
| 1-6-8 | Include the Digits (Destination) parameter set equal to the TLDN. | 42 |
| 1-6-9 | Assign a billing identifier to the TLDN. | 43 |
| 1-6-10 | Include the BillingID parameter set equal to the TLDN billing identifier. | 44 |
| | | 45 |
| 1-6-11 | IF a OneTimeFeatureIndicator parameter is received with received messages: | 46 |
| 1-6-11-1 | Store the parameter overriding the MS profile information. | 47 |
| | | 48 |
| 1-6-12 | ENDIF. | 49 |
| | | 50 |
| 1-6-13 | Store the received MSCID parameter as the Originating MSC identifier and information related to the indicated termination with the assigned TLDN. | 51 |
| | | 52 |
| 1-6-14 | IF the CallingPartyNumberString1 parameter is received: | 53 |
| 1-6-14-1 | Store the CallingPartyNumberString1 parameter to identify the calling party. | 54 |
| | | 55 |
| | | 56 |
| 1-6-15 | ENDIF. | 57 |
| | | 58 |
| | | 59 |
| | | 60 |

1 1-6-16 IF the CallingPartyNumberString2 parameter is received:
2
3 1-6-16-1 Store the CallingPartyNumberString2 parameter to identify the calling
4 party.
5 1-6-17 ENDIF.
6 1-6-18 IF the CallingPartySubaddress parameter is received:
7
8 1-6-18-1 Store the CallingPartySubaddress parameter to identify the calling
9 party.
10 1-6-19 ENDIF.
11 1-6-20 IF the RedirectingNumberString parameter is received:
12
13 1-6-20-1 Store the RedirectingNumberString parameter to identify the calling
14 party.
15 1-6-21 ENDIF.
16 1-6-22 IF the RedirectingSubaddress parameter is received:
17
18 1-6-22-1 Store the RedirectingSubaddress parameter to identify the calling party.
19 1-6-23 ENDIF.
20 1-6-24 IF the MSCIdentificationNumber parameter is received:
21
22 1-6-24-1 Store the MSCIdentificationNumber parameter to identify the calling
23 party.
24 1-6-25 ENDIF.
25 1-6-26 Include the MSCID parameter set to the identity of the MSC.
26 1-6-27 Include the MSCIdentificationNumber parameter set to the MSC's ID
27 information.
28 1-6-28 Include the PC_SSN parameter with the Type set to *Serving MSC* and the
29 PC and SSN fields set to the MSC's point code and subsystem number.
30 1-6-29 Send a RETURN RESULT to the requesting VLR.
31 1-6-30 Execute the "Wait for TLDN Call" task (see 3.3.2).
32
33 1-7 ELSE (no TLDN is available):
34 1-7-1 Discard any included parameters.
35 1-7-2 Send a RETURN ERROR with Error Code *ResourceShortage* to the
36 requesting VLR.
37 1-7-3 Exit this task.
38 1-8 ENDIF.
39 2 ELSE (the received message cannot be processed):
40 2-1 Send a RETURN ERROR with a proper Error Code value (see the following
41 table) to the requesting VLR.
42 3 ENDIF.
43 4 Exit this task.
44
45
46
47
48
49
50
51
52
53
54
55
56
57
58
59
60

Table 55 MSC RoutingRequest Response

| Problem Detection and Recommended Response from MSC to VLR | | | | | | | | | | | | |
|--|---|---|---|---|---|---|---|---|---|----|----|-------|
| PROBLEM DEFINITION | 1 | 2 | 3 | 4 | 5 | 6 | 7 | 8 | 9 | 10 | 11 | Notes |
| RETURN ERROR
Error Code | | | | | | | | | | | | |
| <i>UnrecognizedMIN</i> | | | | | | | | | | | | a |
| <i>UnrecognizedESN</i> | | | | | | | X | | | | | |
| <i>MIN/HLRMismatch</i> | | | | | | | | | | | | a |
| <i>OperationSequenceProblem</i> | | | | | | | | | | | | a |
| <i>ResourceShortage</i> | | X | | | | | | | | | | |
| <i>OperationNotSupported</i> | X | | | | | | | | | | | b |
| <i>TrunkUnavailable</i> | | | | | | | | | | | | a |
| <i>ParameterError</i> | | | | X | | | | | | | | d |
| <i>SystemFailure</i> | | | X | | | | | | | | | |
| <i>UnrecognizedParameterValue</i> | | | | | X | | | | | | | d |
| <i>FeatureInactive</i> | | | | | | | | | | | | a |
| <i>MissingParameter</i> | | | | | | X | | | | | | d |
| RETURN RESULT
AccessDeniedReason | | | | | | | | | | | | c, e |
| <i>Unassigned directory number</i> | | | | | | | | | | | | f |
| <i>Inactive</i> | | | | | | | | X | | | | |
| <i>Busy</i> | | | | | | | | | X | | | |
| <i>Termination Denied</i> | | | | | | | | | | | | f |
| <i>No Page Response</i> | | | | | | | | | | X | | |
| <i>Unavailable</i> | | | | | | | | | | | X | |

Problem Detections:

1. The requested MAP operation is recognized, but not supported, by the receiving MSC, or the requesting functional entity is not authorized.
2. A required MSC resource (e.g., internal memory record, MSC is fully occupied) is temporarily not available (e.g., congestion).
3. A required resource (e.g., data base access, functional entity) is not presently accessible due to a failure. Human intervention may be required for resolution.
4. A supplied parameter has an encoding problem (e.g., the supplied MobileIdentificationNumber parameter digit values do not meet the BCD specification).
5. A supplied parameter value is unrecognized or has nonstandard values (e.g., *Not used*).
6. An expected, or required, optional parameter (e.g., PC_SSN) was not received.
7. An MSC record exists for the supplied MobileIdentificationNumber parameter, but the supplied ElectronicSerialNumber parameter does not match the ESN in the MSC record.
8. An MSC record exists for the supplied MobileIdentificationNumber parameter, but the MIN's status is *Inactive* (powered down, failed to autonomously register). QualificationDirective profile updates to the MSC may continue and RoutingRequests may be suppressed until re-registration occurs.
9. An MSC record exists for the supplied MobileIdentificationNumber parameter, but the MIN's status is *Busy*.
10. An MSC record may exist for the supplied MobileIdentificationNumber parameter, but the MIN did not respond to an attempted page.
11. An MSC record exists for the supplied MobileIdentificationNumber parameter, but the MIN's status is *Unavailable* (powered down, failure to autonomously register). QualificationDirective profile updates and RoutingRequests to the MSC shall continue.

Notes:

- a. This Error Code is not an appropriate MSC response to a RoutingRequest transaction.
- b. It is recommended that an MSC supports RoutingRequest transactions.
- c. Only RETURN RESULT operations needing clarification have been included.
- d. Include the *Parameter Identifier* in question as the FaultyParameter parameter.
- e. An MSC record exists for the supplied MobileIdentificationNumber parameter, but the MIN's status is *Termination Denied* or *Invalid*. The MSC shall appropriately attempt to deliver the call.
- f. This AccessDeniedReason is not an appropriate MSC response to a RoutingRequest transaction.

4.44 SMS DELIVERY BACKWARD

4.44.1 MSC Initiating SMS Delivery Backward

Upon request to send an MS-originated SMS point-to-point message up the handoff chain, the MSC shall do the following:

- 1 Set the underlying transport destination address and the message destination to the next MSC in the handoff chain.
- 2 Include InterMSCCircuitID parameter set to the trunk used in the direction toward the Anchor MSC.
- 3 IF the message destination is not the same as the destination address (i.e., the message is routed through an intervening SMS router or Tandem MSC) and the underlying transport is allowed to carry the destination address:
 - 3-1 IF the message destination is not the same as the underlying transport destination address:
 - 3-1-1 Include the SMS_DestinationAddress parameter set to the destination address.
 - 3-2 ENDIF.
 - 4 ENDIF.
- 5 IF the original message destination is not the same as the destination address:
 - 5-1 Include the SMS_OriginalDestinationAddress parameter set to the original destination address.
 - 6 ENDIF.
- 7 Set the underlying transport originating address to the address of this functional entity.
- 8 IF the originating address is different than the originating address of this functional entity (i.e., this functional entity is a Tandem MSC or an intervening SMS router) and the underlying transport is allowed to carry the originating address.
 - 8-1 Include the SMS_OriginatingAddress parameter set to the originating address.
 - 9 ENDIF.
- 10 IF the message original originating address is not the same as the originating address:
 - 10-1 Include the SMS_OriginalOriginatingAddress parameter set to the original originating address.
 - 11 ENDIF.
- 12 Send a SMSDeliveryBackward INVOKE message toward the Destination Address.
- 13 Start the Short Message Backward Timer (SBT).
- 14 WAIT for an SMS Delivery Backward response:

- 15 WHEN a RETURN RESULT is received: 1
- 15-1 Stop the timer (SBT). 2
- 15-2 IF the message can be processed: 3
- 15-2-1 Relay all parameters received. 4
- 15-2-2 Return to the calling task as accepted. 5
- 15-3 ELSE (the message cannot be processed): 6
- 15-3-1 Return to the calling task with the SMS_CauseCode indicating *Other Network Problem*. 7
- 15-4 ENDIF. 8
- 16 WHEN a RETURN ERROR¹ is received: 9
- 16-1 Stop the timer (SBT). 10
- 16-2 Return to the calling task with the SMS_CauseCode indicating *Other Network Problem*. 11
- 17 WHEN a REJECT is received: 12
- 17-1 Stop the timer (SBT). 13
- 17-2 CASE reject problem specifier OF: 14
- 17-3 *Unrecognized component*, 15
- 17-4 *Incorrect component portion*, 16
- 17-5 *Badly structured component portion*, 17
- 17-6 *Incorrect parameter*, 18
- 17-7 *Unrecognized package type*, 19
- 17-8 *Incorrect transaction portion*, 20
- 17-9 *Badly structured transaction portion*: 21
- 17-9-1 Return to the calling task with the SMS_CauseCode indicating *Encoding Problem*. 22
- 17-10 *Unrecognized operation code*: 23
- 17-10-1 Return to the calling task with the SMS_CauseCode indicating *SMS not supported*. 24
- 17-11 *DEFAULT*: 25
- 17-12 Return to the calling task with the SMS_CauseCode indicating *Network failure*. 26
- 17-13 ENDCASE: 27
- 18 WHEN the timer (SBT) expires: 28
- 18-1 Return to the calling task with the SMS_CauseCode indicating *Network failure*. 29
- 19 ENDWAIT. 30

¹The sending of an SMS DeliveryBackward RETURN ERROR is not recommended and error tables are not supplied. 31

4.44.2 MSC Receiving an SMSDeliveryBackward INVOKE

Upon receipt of an SMSDeliveryBackward INVOKE, the MSC shall do the following:

- 1 IF the received message can be processed:
 - 1-1 IF the SMS_DestinationAddress parameter is received:
 - 1-1-1 Set the destination address with the address in the received SMS_DestinationAddress parameter.
 - 1-2 ELSEIF the underlying transport can carry the destination address:
 - 1-2-1 Set the destination address with the destination address used by the underlying transport mechanism.
 - 1-3 ELSE:
 - 1-3-1 Include the SMS_CauseCode parameter set to *Missing Expected Parameter*.
 - 1-3-2 Send a RETURN RESULT.
 - 1-3-3 Exit this task.
 - 1-4 ENDIF.
 - 1-5 IF the SMS_OriginalDestinationAddress parameter is received:
 - 1-5-1 Set the original destination address with the address in the received SMS_OriginalDestinationAddress parameter.
 - 1-6 ELSE:
 - 1-6-1 Set the original destination address with the destination address.
 - 1-7 ENDIF.
 - 1-8 IF the SMS_OriginatingAddress parameter is received:
 - 1-8-1 Set the originating address with received SMS_OriginatingAddress..
 - 1-9 ELSEIF the MobileIdentificationNumber parameter is received:
 - 1-9-1 Set the originating address to the MobileIdentificationNumber.
 - 1-10 ELSEIF the underlying transport can carry the originating address:
 - 1-10-1 Set the originating address with the originating address used by the underlying transport mechanism.
 - 1-11 ELSE:
 - 1-11-1 Include the SMS_CauseCode parameter set to *Missing Expected Parameter*.
 - 1-11-2 Send a RETURN RESULT.
 - 1-11-3 Exit this task.
 - 1-12 ENDIF.
 - 1-13 IF the SMS_OriginalOriginatingAddress parameter is received:
 - 1-13-1 Set the original originating address with the address in the received SMS_OriginalOriginatingAddress parameter.
 - 1-14 ELSE:
 - 1-14-1 Set the original originating address with the originating address.
 - 1-15 ENDIF.
 - 1-16 Relay all parameters received.
 - 1-17 IF the MSC is the Anchor MSC:

- 1-17-1 Execute the “Anchor MSC Initiating SMS Delivery Point-To-Point” task (see 4.46.5). 1
2
- 1-17-2 Relay all parameters received. 3
4
- 1-18 ELSE (the MSC is a Tandem MSC): 5
6
- 1-18-1 IF the next MSC in the handoff chain is known to support SMS: 7
- 1-18-1-1 Discard the InterMSCCircuitID parameter. 8
- 1-18-1-2 Execute the “MSC Initiating SMS Delivery Backward” task (see 4.44.1). 9
10
- 1-18-1-3 Relay all parameters received. 11
- 1-18-2 ELSE (the handing-off system does not support SMS): 12
- 1-18-2-1 Include the SMS_CauseCode parameter set to *Network failure*. 13
14
- 1-18-3 ENDIF. 15
- 1-19 ENDIF. 16
- 1-20 Send a RETURN RESULT towards the Serving MSC. 17
18
- 2 ELSE (the received message cannot be processed): 19
- 2-1 Include the SMS_CauseCode parameter indicating the proper value. 20
21
- 2-2 Send a RETURN RESULT. 22
- 3 ENDIF. 23
24
- 4 Exit this task. 25
26
27

4.45 SMS DELIVERY FORWARD 28

4.45.1 MSC Initiating SMS Delivery Forward 29

Upon request to send an MS terminated SMS point-to-point message down a handoff chain, the MSC shall do the following: 30
31
32
33

- 1 Relay included parameters. 34
35
36
- 2 Set the underlying transport destination address and the message destination to the next MSC in the handoff chain. 37
38
39
- 3 Include InterMSCCircuitID parameter set to the trunk used in the direction toward the Serving MSC. 40
41
- 4 IF the message destination is not the same as the destination address (i.e., the message is routed through an intervening SMS router or Tandem MSC) and the underlying transport is allowed to carry the destination address: 42
43
44
45
- 4-1 IF the message destination is not the same as the MobileIdentificationNumber parameter: 46
47
- 4-1-1 Include the SMS_DestinationAddress parameter set to the destination address. 48
49
- 4-2 ENDIF. 50
- 5 ENDIF. 51
52
- 6 IF the original message destination is not the same as the destination address: 53
- 6-1 Include the SMS_OriginalDestinationAddress parameter set to the original destination address. 54
55
- 7 ENDIF. 56
57
58
59
60

- 1
2
3
4
5
6
7
8
9
10
11
12
13
14
15
16
17
18
19
20
21
22
23
24
25
26
27
28
29
30
31
32
33
34
35
36
37
38
39
40
41
42
43
44
45
46
47
48
49
50
51
52
53
- 8 Set the underlying transport originating address to the address of this functional entity.
 - 9 IF the originating address is different than the originating address of this functional entity (i.e., this functional entity is a Tandem MSC or an intervening SMS router) and the underlying transport is allowed to carry the originating address.
 - 9-1 Include the SMS_OriginatingAddress parameter set to the originating address.
 - 10 ENDIF.
 - 11 IF the message original originating address is not the same as the originating address:
 - 11-1 Include the SMS_OriginalOriginatingAddress parameter set to the original originating address.
 - 12 ENDIF.
 - 13 Send a SMSDeliveryForward INVOKE message toward the MSC currently serving the destination MS.
 - 14 Start the Short Message Forward Timer (SFT).
 - 15 WAIT for an SMS Delivery Forward response:
 - 16 WHEN a RETURN RESULT is received:
 - 16-1 Stop the timer (SFT).
 - 16-2 IF the message can be processed:
 - 16-2-1 Return to the calling task with the received parameters.
 - 16-3 ELSE (the message cannot be processed):
 - 16-3-1 Include the SMS_CauseCode parameter indicating *Other Network Problem*.
 - 16-3-2 Return to the calling task.
 - 16-4 ENDIF.
 - 17 WHEN a RETURN ERROR¹ is received:
 - 17-1 Stop the timer (SFT).
 - 17-2 Include the SMS_CauseCode parameter indicating *Other Network Problem*.
 - 17-3 Return to the calling task.
 - 18 WHEN a REJECT is received:
 - 18-1 Stop the timer (SBT).
 - 18-2 CASE reject problem specifier OF:
 - 18-3 *Unrecognized component,*
 - 18-4 *Incorrect component portion,*
 - 18-5 *Badly structured component portion,*
 - 18-6 *Incorrect parameter,*
 - 18-7 *Unrecognized package type,*
 - 18-8 *Incorrect transaction portion,*
 - 18-9 *Badly structured transaction portion:*
 - 18-9-1 Return to the calling task with the SMS_CauseCode indicating *Encoding Problem*.

¹The sending of an SMS DeliveryForward RETURN ERROR is not recommended and error tables are not supplied.

- 18-10 *Unrecognized operation code:*
- 18-10-1 Return to the calling task with the SMS_CauseCode indicating *SMS not supported.*
- 18-11 *DEFAULT:*
- 18-11-1 Return to the calling task with the SMS_CauseCode indicating *Network failure.*
- 18-12 *ENDCASE:*
- 19 *WHEN* the timer (SFT) expires:
- 19-1 Include the SMS_CauseCode parameter indicating *Network failure.*
- 19-2 Return to the calling task.
- 20 *ENDWAIT.*

4.45.2 MSC Receiving an SMSDeliveryForward INVOKE

Upon receipt of an SMSDeliveryForward INVOKE, the MSC shall do the following:

- 1 *IF* the received message can be processed:
- 1-1 *IF* the SMS_DestinationAddress parameter is received:
- 1-1-1 Set the destination address with the address in the received SMS_DestinationAddress parameter.
- 1-2 *ELSEIF* the MobileIdentificationNumber parameter is received:
- 1-2-1 Set the destination address to the MobileIdentificationNumber..
- 1-3 *ELSEIF* the underlying transport can carry the destination address:
- 1-3-1 Set the destination address with the destination address used by the underlying transport mechanism.
- 1-4 *ELSE:*
- 1-4-1 Include the SMS_CauseCode parameter set to *Missing Expected Parameter.*
- 1-4-2 Send a RETURN RESULT.
- 1-4-3 Exit this task.
- 1-5 *ENDIF.*
- 1-6 *IF* the SMS_OriginalDestinationAddress parameter is received:
- 1-6-1 Set the original destination address with the address in the received SMS_OriginalDestinationAddress parameter.
- 1-7 *ELSE:*
- 1-7-1 Set the original destination address with the destination address.
- 1-8 *ENDIF.*
- 1-9 *IF* the SMS_OriginatingAddress parameter is received:
- 1-9-1 Set the originating address with received SMS_OriginatingAddress.
- 1-10 *ELSEIF* the underlying transport can carry the originating address:
- 1-10-1 Set the originating address with the originating address used by the underlying transport mechanism.
- 1-11 *ELSE:*
- 1-11-1 Include the SMS_CauseCode parameter set to *Missing Expected Parameter.*
- 1-11-2 Send a RETURN RESULT.

- 1-11-3 Exit this task.
- 1-12 ENDIF.
- 1-13 IF the SMS_OriginalOriginatingAddress parameter is received:
- 1-13-1 Set the original originating address with the address in the received SMS_OriginalOriginatingAddress parameter.
- 1-14 ELSE:
- 1-14-1 Set the original originating address with the originating address.
- 1-15 ENDIF.
- 1-16 IF the MSC is the Serving MSC:
- 1-16-1 IF the MS is currently able to receive SMS messages:
- 1-16-1-1 Execute the “MSC Initiating SMD-REQUEST toward an MS-Based SME” task (see Annex D.1).
- 1-16-1-2 Relay all received parameters.
- 1-16-2 ELSE (the MS is unable to receive SMS messages):
- 1-16-2-1 Include the SMS_CauseCode parameter set to the appropriate value.
- 1-16-3 ENDIF.
- 1-17 ELSE (this is a Tandem MSC):
- 1-17-1 IF the next MSC in the handoff chain is known to support SMS:
- 1-17-1-1 Discard the InterMSCCircuitID parameter.
- 1-17-1-2 Execute “MSC Initiating SMSDeliveryForward” (see 4.45.1) toward the Serving MSC in the call.
- 1-17-1-3 Relay all received parameters.
- 1-17-2 ELSE (the handed-off system does not support SMS):
- 1-17-2-1 Include the SMS_CauseCode parameter set to *Network failure*.
- 1-17-3 ENDIF.
- 1-18 ENDIF.
- 2 ELSE (the received message cannot be processed):
- 2-1 Include the SMS_CauseCode parameter with the appropriate value.
- 3 ENDIF.
- 4 Send a RETURN RESULT.
- 5 Exit this task.

4.46 SMS DELIVERY POINT-TO-POINT

4.46.1 SME Initiating SMS Delivery

Upon a request to deliver a short message, the originating SME shall do the following:

- 1 IF the request can be processed:
- 1-1 IF originating supplementary services are required:
- 1-1-1 Set the destination address to the originating SME’s address (i.e., the address of the originating SME’s MC).

| | | |
|---------|---|----------------------------|
| 1-1-2 | IF notification is required: | 1 |
| 1-1-2-1 | Optionally, include the SMS_NotificationIndicator parameter set to <i>Notify When Available</i> . | 2
3
4 |
| 1-1-2-2 | Optionally, include the SMS_MessageCount parameter set to the number of queued messages. | 5
6 |
| 1-1-3 | ELSE: | 7 |
| 1-1-3-1 | Include the SMS_NotificationIndicator parameter set to <i>Do Not Notify When Available</i> . | 8
9
10 |
| 1-1-4 | ENDIF. | 11 |
| 1-2 | ELSEIF the destination is known to be an MS-based SME: | 12 |
| 1-2-1 | IF the originating SME is HLR-based and the MS is subscribed to the HLR and the temporary SMS address for the MS is current (as determined by the HLR): | 13
14
15
16 |
| 1-2-1-1 | Set the destination address to the temporary SMS address for the addressed MS. | 17
18
19 |
| 1-2-1-2 | Include the ElectronicSerialNumber parameter for the indicated MS. | 20 |
| 1-2-1-3 | Include the MobileIdentificationNumber parameter for the indicated MS. | 21 |
| 1-2-2 | ELSEIF the originating SME is MSC-based and the destination MS-based SME is currently served or anchored by the MSC: | 22
23
24 |
| 1-2-2-1 | Set the destination address to the air interface address of the MS (usually its MIN). | 25
26
27 |
| 1-2-2-2 | Include the ElectronicSerialNumber parameter for the indicated MS. | 28 |
| 1-2-2-3 | Include the MobileIdentificationNumber parameter for the indicated MS. | 29 |
| 1-2-3 | ELSE (the destination address should be treated normally): | 30
31 |
| 1-2-3-1 | Set the destination address to the address of the destination MS-based SME (i.e., the address of the destination MS-based SME's MC). | 32
33
34 |
| 1-2-4 | ENDIF. | 35 |
| 1-2-5 | Include the SMS_NotificationIndicator parameter set to <i>Do Not Notify When Available</i> . | 36
37
38 |
| 1-3 | ELSE (the destination is unknown and originating supplementary services are not required): | 39
40 |
| 1-3-1 | Set the destination address to the address of the destination SME. | 41 |
| 1-3-2 | IF notification is required: | 42 |
| 1-3-2-1 | Optionally, include the SMS_NotificationIndicator parameter set to <i>Notify When Available</i> . | 43
44
45 |
| 1-3-2-2 | Optionally, include the SMS_MessageCount parameter set to the number of queued messages. | 46
47 |
| 1-3-3 | ELSE: | 48 |
| 1-3-3-1 | Include the SMS_NotificationIndicator parameter set to <i>Do Not Notify When Available</i> . | 49
50
51 |
| 1-3-4 | ENDIF. | 52 |
| 1-4 | ENDIF. | 53
54 |
| 1-5 | Include the SMS_BearerData parameter set by the SMS teleservice. | 55 |
| 1-6 | Include the SMS_TeleserviceIdentifier parameter set to identify the SMS teleservice. | 56
57
58
59
60 |

- 1-7 IF the originating SME is MS-based:
- 1-7-1 Execute the “MS-Based SME Initiating SMD-REQUEST toward an MSC” task (see Annex D.4).
- 1-8 ELSEIF the originating SME is MSC-based and the destination is a served MS:
- 1-8-1 IF the MSC is serving the indicated MS:
- 1-8-1-1 Execute the “MSC Initiating SMD-REQUEST toward an MS-Based SME” task (see Annex D.1).
- 1-8-2 ELSE (the MSC must be the Anchor MSC for the indicated MS):
- 1-8-2-1 Execute the “MSC Initiating SMS Delivery Forward” task (see 4.45.1).
- 1-8-3 ENDIF.
- 1-9 ELSE (the originating SME is not MS- or MSC-based):
- 1-9-1 Execute the “Initiating SMS Delivery Point-To-Point” task (see 4.46.2).
- 1-10 ENDIF.
- 1-11 IF the request was *accepted*:
- 1-11-1 Release the message.
- 1-11-2 Return to the calling task with all received parameters and an *accepted* indication.
- 1-12 ELSEIF the request was *postponed*:
- 1-12-1 Return to the calling task with all received parameters and a *postponed* indication.
- 1-13 ELSE (the request was *denied*):
- 1-13-1 Execute “Local Recovery Procedures” task (see 3.5.1).
- 1-13-2 Return to the calling task with a *denied* indication.
- 1-14 ENDIF.
- 2 ELSE:
- 2-1 Return to the calling task with a *denied* indication.
- 3 ENDIF.

4.46.2 Initiating SMS Delivery Point-To-Point

This task assumes that it is called by a higher function capable of acting upon returned SMS_CauseCode appropriately. The calling function should also 1) set the destination address, and it should include the ElectronicSerialNumber, MobileIdentificationNumber, SMS_MessageCount and SMS_NotificationIndicator parameters, if appropriate. Upon request, a SME or MC shall do the following:

- 1 Relay included parameters.
- 2 IF appropriate:
 - 2-1 Include the SMS_ChargeIndicator parameter set appropriately.
- 3 ENDIF.
- 4 Set the underlying transport destination address to the message destination.
- 5 IF the message destination is not the same as the destination address (i.e., the message is routed through an intervening SMS router or Tandem MSC) and the underlying transport is allowed to carry the destination address:
 - 5-1 IF the message destination is not the same as the MobileIdentificationNumber:

| | | |
|------------|--|----|
| 5-1-1 | Include the SMS_DestinationAddress parameter set to the destination address. | 1 |
| 5-2 | ENDIF. | 2 |
| 6 | ENDIF. | 3 |
| 7 | IF the original message destination is not the same as the destination address: | 4 |
| 7-1 | Include the SMS_OriginalDestinationAddress parameter set to the original destination address. | 5 |
| 8 | ENDIF. | 6 |
| 9 | IF appropriate: | 7 |
| 9-1 | Include the SMS_OriginalDestinationSubaddress parameter set appropriately. | 8 |
| 10 | ENDIF. | 9 |
| 11 | Set the underlying transport originating address to the address of this functional entity. | 10 |
| 12 | IF the originating address is different than the originating address of this functional entity (i.e., this functional entity is a Tandem MSC or an intervening SMS router) and the underlying transport is allowed to carry the originating address. | 11 |
| 12-1 | Include the SMS_OriginatingAddress parameter set to the originating address. | 12 |
| 13 | ENDIF. | 13 |
| 14 | IF the original message originating is not the same as the originating address: | 14 |
| 14-1 | Include the SMS_OriginalOriginatingAddress parameter set to the original originating address. | 15 |
| 15 | ENDIF. | 16 |
| 16 | IF appropriate: | 17 |
| 16-1 | Include the SMS_OriginalOriginatingSubaddress parameter set appropriately. | 18 |
| 17 | ENDIF. | 19 |
| 18 | Send a SMSDeliveryPointToPoint INVOKE message. | 20 |
| 19 | Start the SMS Delivery Timer (SMT). | 21 |
| 20 | WAIT for an SMSDeliveryPointToPoint response: | 22 |
| 21 | WHEN a RETURN RESULT is received: | 23 |
| 21-1 | Stop the timer (SMT). | 24 |
| 21-2 | IF the message can be processed: | 25 |
| 21-2-1 | IF the SMS_CauseCode parameter is received: | 26 |
| 21-2-1-1 | IF the SMS_CauseCode is <i>SMS delivery postponed</i> : | 27 |
| 21-2-1-1-1 | Return to the calling task with all received parameters and a <i>postponed</i> indication. | 28 |
| 21-2-1-2 | ELSEIF the SMS_CauseCode is <i>Destination Resource Shortage</i> : | 29 |
| 21-2-1-2-1 | Execute local recovery procedures to determine when it is acceptable to transmit again to the SME. | 30 |
| 21-2-1-2-2 | Return to the calling task with all received parameters and a <i>refused</i> indication. | 31 |
| 21-2-1-3 | ELSE: | 32 |
| 21-2-1-3-1 | Return to the calling task with all received parameters and a <i>refused</i> indication. | 33 |
| 21-2-1-4 | ENDIF. | 34 |
| 21-2-2 | ELSE: | 35 |
| | | 36 |
| | | 37 |
| | | 38 |
| | | 39 |
| | | 40 |
| | | 41 |
| | | 42 |
| | | 43 |
| | | 44 |
| | | 45 |
| | | 46 |
| | | 47 |
| | | 48 |
| | | 49 |
| | | 50 |
| | | 51 |
| | | 52 |
| | | 53 |
| | | 54 |
| | | 55 |
| | | 56 |
| | | 57 |
| | | 58 |
| | | 59 |
| | | 60 |

1 21-2-2-1 Return to the calling task with all received parameters and an *accepted*
2 indication.
3
4 21-2-3 ENDIF.
5 21-3 ELSE (the message cannot be processed):
6 21-3-1 Return to the calling task with a *denied* indication.
7
8 21-4 ENDIF.
9
10 22 WHEN a RETURN ERROR¹ is received:
11 22-1 Stop the timer (SMT).
12 22-2 Set the SMS_CauseCode to *Network failure*.
13 22-3 Return to the calling task with a *denied* indication.
14
15 23 WHEN a REJECT is received:
16 23-1 Stop the timer (SMT).
17 23-2 CASE reject problem specifier OF:
18 23-3 *Unrecognized component*,
19 23-4 *Incorrect component portion*,
20 23-5 *Badly structured component portion*,
21 23-6 *Incorrect parameter*,
22 23-7 *Unrecognized package type*,
23 23-8 *Incorrect transaction portion*,
24 23-9 *Badly structured transaction portion*:
25 23-9-1 Set the SMS_CauseCode to *Encoding Problem*.
26 23-10 *Unrecognized operation code*:
27 23-10-1 Set the SMS_CauseCode to *SMS not supported*.
28 23-11 DEFAULT:
29 23-11-1 Set the SMS_CauseCode to *Network failure*.
30 23-12 ENDCASE:
31 23-13 Return to the calling task with a *denied* indication.
32
33 24 WHEN the timer (SMT) expires:
34 24-1 Return to the calling task with a with a *denied* indication.
35
36 25 ENDWAIT.
37
38 26 Exit this task.

4.46.3 SME Receiving an SMSDeliveryPointToPoint INVOKE

Upon receipt of a SMSDeliveryPointToPoint INVOKE, the SME shall do the following:

1 IF the message can be processed:
1-1 IF the SMS_DestinationAddress parameter is received:

¹The sending of an SMS DeliveryPointToPoint RETURN ERROR is not recommended and error tables are not supplied.

| | | |
|--------|--|----|
| 1-1-1 | Set the destination address with the address in the received SMS_DestinationAddress parameter. | 1 |
| | | 2 |
| | | 3 |
| 1-2 | ELSEIF the MobileIdentificationNumber parameter is received: | 4 |
| 1-2-1 | Set the destination address to the MobileIdentificationNumber. | 5 |
| | | 6 |
| 1-3 | ELSEIF the underlying transport can carry the destination address: | 7 |
| 1-3-1 | Set the destination address with the destination address used by the underlying transport mechanism. | 8 |
| | | 9 |
| 1-4 | ELSE: | 10 |
| 1-4-1 | Include the SMS_CauseCode parameter set to <i>Missing Expected Parameter</i> . | 11 |
| 1-4-2 | Send a RETURN RESULT. | 12 |
| 1-4-3 | Exit this task. | 13 |
| | | 14 |
| | | 15 |
| 1-5 | ENDIF. | 16 |
| 1-6 | IF the MobileIdentificationNumber parameter is received: | 17 |
| 1-6-1 | Set the MIN to the received MobileIdentificationNumber parameter. | 18 |
| | | 19 |
| 1-7 | ENDIF. | 20 |
| | | 21 |
| 1-8 | IF the ElectronicSerialNumber parameter is received: | 22 |
| 1-8-1 | Set the ESN to the received ElectronicSerialNumber parameter. | 23 |
| | | 24 |
| 1-9 | ENDIF. | 25 |
| 1-10 | IF the SMS_OriginalDestinationAddress parameter is received: | 26 |
| 1-10-1 | Set the original destination address with the address in the received SMS_OriginalDestinationAddress parameter. | 27 |
| | | 28 |
| | | 29 |
| 1-11 | ELSE: | 30 |
| 1-11-1 | Set the original destination address with the destination address. | 31 |
| | | 32 |
| 1-12 | ENDIF. | 33 |
| 1-13 | IF the SMS_OriginalDestinationSubaddress parameter is received: | 34 |
| 1-13-1 | Set the original destination subaddress with the address in the received SMS_OriginalDestinationSubaddress parameter. | 35 |
| | | 36 |
| | | 37 |
| 1-14 | ELSE: | 38 |
| 1-14-1 | Set the original destination subaddress with a locally defined default subaddress. | 39 |
| | | 40 |
| | | 41 |
| 1-15 | ENDIF. | 42 |
| 1-16 | IF the MIN, ESN, original destination address, destination address or original destination subaddress is not for this SME: | 43 |
| | | 44 |
| 1-16-1 | Include the SMS_CauseCode parameter set to <i>Address translation failure</i> . | 45 |
| 1-16-2 | Send a RETURN RESULT. | 46 |
| 1-16-3 | Exit this task. | 47 |
| | | 48 |
| | | 49 |
| 1-17 | ENDIF. | 50 |
| 1-18 | IF the SMS_OriginatingAddress parameter is received: | 51 |
| 1-18-1 | Set the originating address with received SMS_OriginatingAddress. | 52 |
| | | 53 |
| 1-19 | ELSEIF the underlying transport can carry the originating address: | 54 |
| 1-19-1 | Set the originating address with the originating address used by the underlying transport mechanism. | 55 |
| | | 56 |
| | | 57 |
| 1-20 | ELSE: | 58 |
| | | 59 |
| | | 60 |

1 1-20-1 Include the SMS_CauseCode parameter set to *Missing Expected Parameter*.

2 1-20-2 Send a RETURN RESULT.

3

4 1-20-3 Exit this task.

5 1-21 ENDIF.

6 1-22 IF the SMS_OriginalOriginatingAddress parameter is received:

7

8 1-22-1 Set the original originating address with the address in the received

9 SMS_OriginalOriginatingAddress parameter.

10

11 1-23 ELSE:

12 1-23-1 Set the original originating address with the originating address.

13

14 1-24 ENDIF.

15 1-25 IF the SMS_OriginalOriginatingSubaddress parameter is received:

16

17 1-25-1 Set the original originating subaddress with the address in the received

18 SMS_OriginalOriginatingSubaddress parameter.

19 1-26 ENDIF.

20 1-27 IF the SMS_BearerData parameter is included:

21

22 1-27-1 Set the bearer data to the SMS_BearerData parameter:

23

24 1-28 ELSE:

25 1-28-1 Include the SMS_CauseCode parameter set to *Missing MandatoryParameter*.

26 1-28-2 Send a RETURN RESULT.

27 1-28-3 Exit this task.

28 1-29 ENDIF.

29 1-30 IF the SMS_TeleserviceIdentifier parameter is included:

30

31 1-30-1 IF the SMS_TeleserviceIdentifier parameter is known and supported:

32

33 1-30-1-1 Process the message with the indicated teleservice.

34 1-30-1-2 Send an SMSDeliveryPointToPoint RETURN RESULT with parameters

35 loaded according to the teleservice.

36

37 1-30-1-3 Exit this task.

38 1-30-2 ELSE:

39 1-30-2-1 Include the SMS_CauseCode parameter set to *Invalid Teleservice ID*.

40 1-30-2-2 Send a RETURN RESULT.

41 1-30-2-3 Exit this task.

42

43 1-30-3 ENDIF.

44

45 1-31 ELSE:

46

47 1-31-1 Include the SMS_CauseCode parameter set to *Missing MandatoryParameter*.

48 1-31-2 Send a RETURN RESULT.

49 1-31-3 Exit this task.

50 1-32 ENDIF.

51

52 2 ELSE:

53

54 2-1 Include the SMS_CauseCode parameter with the appropriate value.

55 2-2 Send a RETURN RESULT.

56

57 3 ENDIF.

58 4 Exit this task.

59

60

4.46.4 MSC Receiving an SMSDeliveryPointToPoint INVOKE

Upon receipt of an SMSDeliveryPointToPoint INVOKE for an intended MS, the receiving MSC shall do the following:

- 1 IF the message can be processed:
 - 1-1 IF the SMS_DestinationAddress parameter is received:
 - 1-1-1 Set the destination address with the address in the received SMS_DestinationAddress parameter.
 - 1-2 ELSEIF the MobileIdentificationNumber parameter is received:
 - 1-2-1 Set the destination address to the MobileIdentificationNumber.
 - 1-3 ELSEIF the underlying transport can carry the destination address:
 - 1-3-1 Set the destination address with the destination address used by the underlying transport mechanism.
 - 1-4 ELSE:
 - 1-4-1 Include the SMS_CauseCode parameter set to *Missing Expected Parameter*.
 - 1-4-2 Send a RETURN RESULT.
 - 1-4-3 Exit this task.
 - 1-5 ENDIF.
 - 1-6 IF the SMS_OriginalDestinationAddress parameter is received:
 - 1-6-1 Set the original destination address with the address in the received SMS_OriginalDestinationAddress parameter.
 - 1-7 ELSE:
 - 1-7-1 Set the original destination address with the destination address.
 - 1-8 ENDIF.
 - 1-9 IF the SMS_OriginatingAddress parameter is received:
 - 1-9-1 Set the originating address with received SMS_OriginatingAddress.
 - 1-10 ELSEIF the underlying transport can carry the originating address:
 - 1-10-1 Set the originating address with the originating address used by the underlying transport mechanism.
 - 1-11 ELSE:
 - 1-11-1 Include the SMS_CauseCode parameter set to *Missing Expected Parameter*.
 - 1-11-2 Send a RETURN RESULT.
 - 1-11-3 Exit this task.
 - 1-12 ENDIF.
 - 1-13 IF the SMS_OriginalOriginatingAddress parameter is received:
 - 1-13-1 Set the original originating address with the address in the received SMS_OriginalOriginatingAddress parameter.
 - 1-14 ELSE:
 - 1-14-1 Set the original originating address with the originating address.
 - 1-15 ENDIF.
 - 1-16 IF a MobileIdentificationNumber parameter is received:
 - 1-16-1 Set the MIN to the received MobileIdentificationNumber parameter.

1 1-17 ELSE:
2 1-17-1 Include the SMS_CauseCode parameter set to *Missing Expected Parameter*.
3 1-17-2 Send a RETURN RESULT.
4 1-17-3 Exit this task.
5
6 1-18 ENDIF.
7
8 1-19 IF a ElectronicSerialNumber parameter is received:
9 1-19-1 Set the ESN to the received ElectronicSerialNumber parameter.
10
11 1-20 ELSE:
12 1-20-1 Include the SMS_CauseCode parameter set to *Missing Expected Parameter*.
13 1-20-2 Send a RETURN RESULT.
14 1-20-3 Exit this task.
15
16 1-21 ENDIF.
17
18 1-22 IF the destination MS is anchored by this MSC:
19 1-22-1 IF the MSC is allowed to terminate a short message to the destination MS
20 according to the SMS_TerminationRestrictions parameter in the destination
21 MS's profile:
22
23 1-22-1-1 IF the MSC is currently the Serving MSC:
24 1-22-1-1-1 IF the MS is currently able to receive an SMS message:
25 1-22-1-1-1-1 Optionally, take action to keep the MS in a state in which it can
26 receive SMS messages (e.g., take the MS out of sleep mode).
27 1-22-1-1-1-2 Relay received parameters, except the SMS_ChargeIndicator,
28 SMS_NotificationIndicator , and SMS_MessageCount
29 parameters.
30 1-22-1-1-1-3 Execute the "MSC Initiating SMD-REQUEST toward an MS-
31 Based SME" task (see Annex D.1).
32 1-22-1-1-2 ELSEIF the MS is able to receive only a postponed SMS message
33 (e.g., is busy, radio interface resource shortage, destination SME out
34 of service, in a sleep mode or is inactive):
35 1-22-1-1-2-1 IF the SMS_NotificationIndicator parameter was present in the
36 SMSDeliveryPointToPoint INVOKE and the
37 SMS_NotificationIndicator indicates *Do not notify*
38 *whenavailable*:
39 1-22-1-1-2-1-1 Include the SMS_CauseCode parameter set to an
40 appropriate value.
41 1-22-1-1-2-2 ELSE (notification was requested):
42 1-22-1-1-2-2-1 Set the *SMS Delivery Pending Flag* for this MS.
43 1-22-1-1-2-2-2 Include the SMS_CauseCode parameter set to *SMS Delivery*
44 *Postponed*.
45 1-22-1-1-2-3 ENDIF.
46 1-22-1-1-3 ELSE (the MS is not currently able receive an SMS message):
47 1-22-1-1-3-1 Include the SMS_CauseCode parameter set to *Radio interface*
48 *incompatibility*.
49 1-22-1-1-4 ENDIF.
50 1-22-1-2 ELSE (the MS has been handed off):
51
52
53
54
55
56
57
58
59
60

| | | |
|------------------|---|----------------------------|
| 1-22-1-2-1 | Relay received parameters, except the SMS_ChargeIndicator parameter. | 1
2 |
| 1-22-1-2-2 | Execute the “MSC Initiating SMSDeliveryForward” task (see 4.45.1). | 3
4 |
| 1-22-1-3 | ENDIF.

(At this point, message relaying had been postponed, denied, or attempted.) | 5
6
7
8
9 |
| 1-22-1-4 | IF an SMS_CauseCode has not been included (delivery was successful): | 10 |
| 1-22-1-4-1 | IF the SMS_NotificationIndicator parameter was received and it indicates <i>Do not notify when available</i> : | 11
12 |
| 1-22-1-4-1-1 | (Ignore the previously received SMS_MessageCount, if it is present). | 13
14
15 |
| 1-22-1-4-2 | ELSE (notification was requested): | 16 |
| 1-22-1-4-2-1 | IF the MSC is the Serving MSC: | 17
18 |
| 1-22-1-4-2-1-1 | IF the SMS_MessageCount parameter was not received OR IF the received SMS_MessageCount parameter is zero: | 19
20 |
| 1-22-1-4-2-1-1-1 | Optionally, restore the MS to its prior state (e.g., restore the MS to sleep mode). | 21
22
23 |
| 1-22-1-4-2-1-2 | ELSE (SMS_MessageCount was non-zero): | 24 |
| 1-22-1-4-2-1-2-1 | (Keep the MS awake for a while to receive another possible message.) | 25
26
27 |
| 1-22-1-4-2-1-3 | ENDIF. | 28 |
| 1-22-1-4-2-2 | ENDIF. | 29 |
| 1-22-1-4-2-3 | IF the SMS_MessageCount parameter was not received OR IF the received SMS_MessageCount parameter is zero: | 30
31
32 |
| 1-22-1-4-2-3-1 | Clear the <i>SMS Delivery Pending Flag</i> for this MS. | 33 |
| 1-22-1-4-2-4 | ENDIF. | 34 |
| 1-22-1-4-3 | ENDIF. | 35
36 |
| 1-22-1-4-4 | Relay the received parameters. | 37
38 |
| 1-22-1-5 | ELSE (an SMS_CauseCode has been included): | 39 |
| 1-22-1-5-1 | IF the SMS_CauseCode is from an MS, but it is not a legitimate SMS_CauseCode for an MS to send (e.g., SMS delivery postponed): | 40
41 |
| 1-22-1-5-1-1 | Include the SMS_CauseCode parameter set to <i>Network failure</i> . | 42
43 |
| 1-22-1-5-1-2 | Relay the other received parameters. | 44 |
| 1-22-1-5-2 | ELSEIF the SMS_CauseCode was for a <i>Destination resourceshortage</i> : | 45
46
47 |
| 1-22-1-5-2-1 | Relay all received parameters. | 48 |
| 1-22-1-5-2-2 | Clear the <i>SMS Delivery Pending Flag</i> for this MS. | 49 |
| 1-22-1-5-3 | ELSEIF the SMS_CauseCode was for a temporary condition: | 50 |
| 1-22-1-5-3-1 | IF the SMS_NotificationIndicator parameter was present in the SMSDeliveryPointToPoint INVOKE and the SMS_NotificationIndicator indicates <i>Do not notify whenavailable</i> : | 51
52
53
54
55 |
| 1-22-1-5-3-1-1 | Relay all received parameters. | 56
57
58
59
60 |

1 1-22-1-5-3-2 ELSE (notification was requested):
2 1-22-1-5-3-2-1 Set the *SMS Delivery Pending Flag* for this MS.
3 1-22-1-5-3-2-2 Include the *SMS_CauseCode* parameter set to *SMS Delivery Postponed*.
4 1-22-1-5-3-2-3 Relay the other received parameters.
5 1-22-1-5-3-3 ENDIF.
6 1-22-1-5-4 ELSE (*SMS_CauseCode* is not for a temporary condition):
7 1-22-1-5-4-1 Relay all received parameters.
8 1-22-1-5-5 ENDIF.
9 1-22-1-6 ENDIF.
10 1-22-1-7 Send a RETURN RESULT.
11 1-22-2 ELSE (MSC is not allowed to terminate a short message to the destination MS):
12 1-22-2-1 Include the *SMS_CauseCode* parameter indicating termination is *SMS Termination Denied*.
13 1-22-2-2 Send a RETURN RESULT.
14 1-22-3 ENDIF.
15 1-23 ELSE (MS is not anchored by this MSC):
16 1-23-1 Include the *SMS_CauseCode* parameter set to *Destination no longer at this address*.
17 1-23-2 Send a RETURN RESULT.
18 1-24 ENDIF.
19 2 ELSE (the received message cannot be processed):
20 2-1 Include the *SMS_CauseCode* parameter indicating the proper value.
21 2-2 Send a RETURN RESULT.
22 3 ENDIF.
23 4 Exit this task.

4.46.5 Anchor MSC Initiating SMS Delivery Point-To-Point

This task assumes that it is called by a higher function capable of acting upon returned *SMS_CauseCode* appropriately. Upon request, the Anchor MSC shall do the following:

1 IF the request can be processed:
1-1 IF indirect routing is required by the *SMS_OriginationRestrictions* set to *ForceMessage Center*:
1-1-1 Include the *SMS_DestinationAddress* parameter set to the .
1-2 END IF.
1-3 CASE *SMS_OriginationRestrictions* OF:
1-4 *Block All*:
1-4-1 Include the *SMS_CauseCode* parameter indicating *SMS Origination Restriction*.
1-4-2 Return to the calling task indicating *denied*.
1-5 *Allow Specific*:

| | | |
|-----------|--|----|
| 1-5-1 | IF the MS is not allowed to originate using direct addresses: | 1 |
| 1-5-1-1 | IF the SMS_DestinationAddress parameter is not equal to the SMS_OriginalOriginatingAddress (direct routing requested): | 2 |
| 1-5-1-1-1 | Include the SMS_CauseCode parameter indicating <i>SMS Origination Restriction</i> . | 3 |
| 1-5-1-1-2 | Return to the calling task indicating <i>denied</i> . | 4 |
| 1-5-1-2 | ENDIF. | 5 |
| 1-5-2 | ENDIF. | 6 |
| 1-6 | <i>DEFAULT:</i> | 7 |
| 1-6-1 | (Just allow it.) | 8 |
| 1-7 | ENDCASE. | 9 |
| 1-8 | Relay all included parameters. | 10 |
| 1-9 | Execute the “Initiating SMS Delivery Point-To-Point” task (see 4.46.2). | 11 |
| 1-10 | Return to the calling task with the received parameters and the returned indication. | 12 |
| 2 | ELSE (request cannot be processed): | 13 |
| 2-1 | Include the SMS_CauseCode parameter indicating the appropriate value. | 14 |
| 2-2 | Return to the calling task indicating <i>denied</i> . | 15 |
| 3 | ENDIF. | 16 |
| 4 | Exit this task. | 17 |

4.46.6 MC Receiving an SMSDeliveryPointToPoint INVOKE

Upon receipt of a SMSDeliveryPointToPoint INVOKE, the MC shall do the following:

| | | |
|-------|---|----|
| 1 | IF the message can be processed: | 31 |
| 1-1 | IF the SMS_DestinationAddress parameter is received: | 32 |
| 1-1-1 | Set the destination address with the address in the received SMS_DestinationAddress parameter. | 33 |
| 1-2 | ELSEIF the MobileIdentificationNumber parameter is received: | 34 |
| 1-2-1 | Set the destination address to the MobileIdentificationNumber.. | 35 |
| 1-3 | ELSEIF the underlying transport can carry the destination address: | 36 |
| 1-3-1 | Set the destination address with the destination address used by the underlying transport mechanism. | 37 |
| 1-4 | ELSE: | 38 |
| 1-4-1 | Include the SMS_CauseCode parameter set to <i>Missing Expected Parameter</i> . | 39 |
| 1-4-2 | Send a RETURN RESULT. | 40 |
| 1-4-3 | Exit this task. | 41 |
| 1-5 | ENDIF. | 42 |
| 1-6 | IF the SMS_OriginalDestinationAddress parameter is received: | 43 |
| 1-6-1 | Set the original destination address with the address in the received SMS_OriginalDestinationAddress parameter. | 44 |
| 1-7 | ELSE: | 45 |
| 1-7-1 | Set the original destination address with the destination address. | 46 |

- 1 1-8 ENDIF.
- 2
- 3 1-9 IF the SMS_OriginatingAddress parameter is received:
- 4 1-9-1 Set the originating address with received SMS_OriginatingAddress.
- 5 1-10 ELSEIF the underlying transport can carry the originating address:
- 6 1-10-1 Set the originating address with the originating address used by the underlying
- 7 transport mechanism.
- 8
- 9 1-11 ELSE:
- 10 1-11-1 Include the SMS_CauseCode parameter set to *Missing Expected Parameter*.
- 11 1-11-2 Send a RETURN RESULT.
- 12 1-11-3 Exit this task.
- 13
- 14 1-12 ENDIF.
- 15
- 16 1-13 IF the SMS_OriginalOriginatingAddress parameter is received:
- 17 1-13-1 Set the original originating address with the address in the received
- 18 SMS_OriginalOriginatingAddress parameter.
- 19
- 20 1-14 ELSE:
- 21 1-14-1 Set the original originating address with the originating address.
- 22
- 23 1-15 ENDIF.
- 24 1-16 IF the original originating address is the same as the destination address
- 25 (originating supplementary services may have been requested):
- 26
- 27 1-16-1 IF the original originating address is a SME homed to this MC, the destination
- 28 is legitimate subscriber and the Teleservice is legitimate for the subscriber:
- 29 1-16-1-1 Process the message with the indicated teleservice for immediate
- 30 originating supplementary service processing (e.g., unacceptable bearer
- 31 data, canned responses for delivery schedules) indicated by the message
- 32 or the originating subscriber's SMS profile information.
- 33 1-16-1-2 Send a RETURN RESULT message with parameters loaded according to
- 34 the teleservice.
- 35 1-16-1-3 GOTO the "Originating MC Supplementary Services" task (see 4.46.7).
- 36 1-16-2 ELSE:
- 37 1-16-2-1 Include the SMS_CauseCode parameter indicating the proper value (e.g.,
- 38 *SMS origination denied, Supplementary service not supported*).
- 39 1-16-2-2 Send a RETURN RESULT.
- 40
- 41 1-16-3 ENDIF.
- 42
- 43 1-17 ELSEIF the Original Destination Address is the same as the Destination Address
- 44 (terminating supplementary services may have been requested):
- 45
- 46 1-17-1 IF the destination address is a SME homed to this MC, the destination is
- 47 legitimate subscriber and the Teleservice is legitimate for the subscriber:
- 48 1-17-1-1 Process the message with the indicated teleservice for immediate
- 49 terminating supplementary service processing (e.g., unacceptable bearer
- 50 data, canned responses for on vacation, travel schedules) indicated by the
- 51 message or the destination subscriber's SMS profile information.
- 52 1-17-1-2 Send an SMSDeliveryPointToPoint RETURN RESULT message with
- 53 parameters loaded according to the teleservice.
- 54 1-17-1-3 GOTO the "Terminating MC Supplementary Services" task (see 4.46.8).
- 55 1-17-2 ELSE:
- 56
- 57
- 58
- 59
- 60

- 1-17-2-1 Include the SMS_CauseCode parameter indicating the proper value (e.g., *Address translation failure, Address vacant, Invalid Teleservice ID, SMS termination denied, Supplementary service not supported, SMS not supported*). 1
2
3
4
- 1-17-2-2 Send a RETURN RESULT. 5
6
- 1-17-3 ENDIF. 7
- 1-18 ELSE (the message may have been misrouted to this MC): 8
- 1-18-1 Include the SMS_CauseCode parameter indicating the proper value. 9
10
- 1-18-2 Send a RETURN RESULT. 11
12
- 1-19 ENDIF. 13
- 2 ELSE (the message cannot be processed): 14
- 2-1 Include the SMS_CauseCode parameter indicating the proper value. 15
16
- 2-2 Send a RETURN RESULT. 17
18
- 3 ENDIF. 19
- 4 Exit this task. 20
21
22

4.46.7 Originating MC Supplementary Services

When the Originating MC is ready to process a pending SMSDeliveryPointToPoint INVOKE, the MC shall do the following: 23
24

- 1 Perform any delayed originating supplementary services (e.g., delayed delivery, repeated delivery, distribution list) indicated by the message or the originating subscriber's SMS profile information. 25
26
27
- 2 WHILE originating supplementary service remains incomplete: 28
29
30
- 2-1 Schedule the message for delivery and, when ready, continue. 31
32
- 2-2 Set the Destination Address to the Original Destination Address. 33
34
- 2-3 Include the SMS_BearerData parameter set by the SMS teleservice. 35
36
- 2-4 Include the SMS_TeleserviceIdentifier parameter set to identify the SMS teleservice. 37
38
- 2-5 Execute the "Initiating SMS Delivery Point-To-Point" task (see 4.46.2).² 39
40
- 2-6 IF the request is accepted: 41
- 2-6-1 IF the supplementary service is complete: 42
- 2-6-1-1 Release storage for the message. 43
44
- 2-6-1-2 Exit this task. 45
- 2-6-2 ENDIF. 46
- 2-7 ELSE (the request is *denied*): 47
48
- 2-7-1 Execute "Local Recovery Procedures" task (see 3.5.1). 49
50
- 2-8 ENDIF. 51
- 3 ENDWHILE. 52
53

²This message may be internal to a single MC when the originating SME and destination SME are served by the same MC. 54
55
56
57
58
59
60

- 1
2
3
4
5
6
7
8
9
10
11
12
13
14
15
16
17
18
19
20
21
22
23
24
25
26
27
28
29
30
31
32
33
34
35
36
37
38
39
40
41
42
- 4 Exit this task.

4.46.8 Terminating MC Supplementary Services

When the terminating MC is ready to process a pending SMSDeliveryPointToPoint INVOKE, the MC shall do the following:

- 1 Perform any delayed terminating supplementary services (e.g., delivery to an MS-based SME, message screening) indicated by the message or the destination subscriber's SMS profile information.
- 2 WHILE terminating supplementary service remains incomplete:
 - 2-1 Schedule the message for delivery and, when ready, continue.
 - 2-2 IF the Original Destination Address is for a fixed SME:
 - 2-2-1 Set the Destination Address equal to the Original Destination Address.
 - 2-2-2 Include the SMS_BearerData parameter set by the SMS teleservice.
 - 2-2-3 Include the SMS_TeleserviceIdentifier parameter set to identify the SMS teleservice.
 - 2-2-4 Execute the "Initiating SMS Delivery Point-To-Point" task (see 4.46.2).
 - 2-3 ELSE (the SME is MS based):
 - 2-3-1 Execute the "MC Initiating SMS Delivery Point-To-Point to an MS-BasedSME" task (see 4.46.9).
 - 2-3-2 IF the request was *denied*:
 - 2-3-2-1 Execute "Local Recovery Procedures" task (see 3.5.1).
 - 2-3-3 ENDIF.
 - 2-4 ENDIF.
- 3 ENDWHILE.
- 4 Perform requested post transmission terminating supplementary services (e.g., delivery notification).
- 5 Release storage for the message.
- 6 Exit this task.

4.46.9 MC Initiating SMS Delivery Point-To-Point to an MS-Based SME

Upon request to send a point-to-point SMS message to an MS-based SME, the MC shall do the following:

- 1 IF notification is already pending for this MIN:
 - 1-1 GOTO Wait for Notification.
- 2 ENDIF.
- 3 IF the address for the indicated MS is not current (as determined by internal algorithms of the MC., e.g., any time between never to until revoked):
 - 3-1 IF notification of the presence of the MS is required:
 - 3-1-1 Optionally, include the SMS_NotificationIndicator parameter set to *Notify when available*.
 - 3-2 ELSE:

| | | |
|---------|---|----|
| 3-2-1 | Include the SMS_NotificationIndicator parameter set to <i>Do not notify when available</i> . | 1 |
| | | 2 |
| 3-3 | ENDIF. | 3 |
| | | 4 |
| 3-4 | Execute the “MC Initiating SMS Request” task (see 4.48.1). | 5 |
| | | 6 |
| 3-5 | IF the request was <i>accepted</i> : | 7 |
| 3-5-1 | Store the temporary routing address and the current time. | 8 |
| 3-5-2 | GOTO Send the message. | 9 |
| | | 10 |
| 3-6 | ELSEIF the request was <i>denied</i> or <i>unavailable</i> : | 11 |
| 3-6-1 | Execute “Local Recovery Procedures” task (see 3.5.1). | 12 |
| 3-6-2 | Exit this task. | 13 |
| | | 14 |
| 3-7 | ELSE (the request was postponed which can only happen when notification is requested): | 15 |
| | | 16 |
| | N | 17 |
| | | 18 |
| 3-7-1 | Queue the request. | 19 |
| 3-7-2 | WAIT for MS to become available to receive a short message: | 20 |
| 3-7-3 | WHEN SMSNotification is passed (see 4.47.3): | 21 |
| | | 22 |
| 3-7-3-1 | Remove the request from the queue. | 23 |
| 3-7-3-2 | Store the temporary routing address and the current time. | 24 |
| | | 25 |
| 3-7-4 | WHEN the validity of the message expires: | 26 |
| 3-7-4-1 | Remove the request from the queue. | 27 |
| 3-7-4-2 | Exit this task. | 28 |
| | | 29 |
| 3-7-5 | ENDWAIT. | 30 |
| | | 31 |
| 3-8 | ENDIF. | 32 |
| 4 | ENDIF. | 33 |
| | | 34 |
| | | 35 |
| 5 | IF notification of the presence of the MS is required: | 36 |
| 5-1 | Optionally, include the SMS_NotificationIndicator parameter set to <i>Notify when available</i> . | 37 |
| | | 38 |
| 5-2 | Optionally, include the SMS_MessageCount parameter set to the number of messages pending delivery to this MS. | 39 |
| | | 40 |
| | | 41 |
| 6 | ELSE: | 42 |
| 6-1 | Include the SMS_NotificationIndicator parameter set to <i>Do not notify when available</i> . | 43 |
| | | 44 |
| | | 45 |
| 7 | ENDIF. | 46 |
| | | 47 |
| 8 | Set the underlying transport destination address to the temporary routing address of the MS (from the SMS_Address parameter). | 48 |
| | | 49 |
| 9 | Include the MobileIdentificationNumber parameter set to identify the destination MS. | 50 |
| 10 | Include the ElectronicSerialNumber parameter set to further identify the destination MS. | 51 |
| | | 52 |
| | | 53 |
| 11 | Include the SMS_BearerData parameter set by the SMS teleservice. | 54 |
| 12 | Include the SMS_TeleserviceIdentifier parameter set to identify the SMS teleservice. | 55 |
| 13 | Execute the “Initiating SMS Delivery Point-To-Point” task (see 4.46.2). | 56 |
| | | 57 |
| 14 | IF the indication was <i>accepted</i> : | 58 |
| | | 59 |
| | | 60 |

- 1 14-1 Exit this task.
 2
 3 15 ELSEIF the indication was *postponed*.
 4 15-1 GOTO Wait for Notification.
 5 16 ELSEIF the request resulted in a SMS_CauseCode value of *Destination*
 6 *resourceshortage*:
 7
 8 16-1 Exit this task (the MC will get no further notification).
 9 17 ELSE (the request was *denied*):
 10
 11 17-1 Execute “Local Recovery Procedures” task (see 3.5.1).
 12 18 ENDIF.
 13
 14 18 Exit this task.
 15

4.46.10 SMS Router Receiving an SMSDeliveryPointToPoint INVOKE

18 Upon receipt of an SMSDeliveryPointToPoint INVOKE message, an SMS router shall do
 19 the following:
 20

- 21 1 IF the SMS_DestinationAddress parameter is received:
 22
 23 1-1 Set the destination address with the address in the received
 24 SMS_DestinationAddress parameter.
 25 2 ELSEIF the MobileIdentificationNumber parameter is received:
 26 2-1 Set the destination address to the MobileIdentificationNumber..
 27 3 ELSEIF the underlying transport can carry the destination address:
 28 3-1 Set the destination address with the destination address used by the underlying
 29 transport mechanism.
 30 31
 32 4 ELSE:
 33 4-1 Include the SMS_CauseCode parameter set to *Missing Expected Parameter*.
 34 4-2 Send a RETURN RESULT.
 35 4-3 Exit this task.
 36 37
 38 5 ENDIF.
 39 6 IF the SMS_OriginalDestinationAddress parameter is received:
 40 6-1 Set the original destination address with the address in the received
 41 SMS_OriginalDestinationAddress parameter.
 42 7 ELSE:
 43 7-1 Set the original destination address with the destination address.
 44 45
 46 8 ENDIF.
 47 9 IF the SMS_OriginatingAddress parameter is received:
 48 9-1 Set the originating address with received SMS_OriginatingAddress.
 49 10 ELSEIF the underlying transport can carry the originating address:
 50 10-1 Set the originating address with the originating address used by the underlying
 51 transport mechanism.
 52 53
 54 11 ELSE:
 55 11-1 Include the SMS_CauseCode parameter set to *Missing Expected Parameter*.
 56 11-2 Send a RETURN RESULT.
 57 11-3 Exit this task.
 58
 59
 60

| | | |
|----------|---|----|
| 12 | ENDIF. | 1 |
| | | 2 |
| | | 3 |
| 13 | IF the destination address is for the current functional entity: | 4 |
| 13-1 | IF the original destination address is to be processed by the current functional entity: | 5 |
| | | 6 |
| | | 7 |
| 13-1-1 | Pass the message to the internal SMS user for processing. | 8 |
| 13-1-2 | Exit this task. | 9 |
| | | 10 |
| 13-2 | ELSE: | 11 |
| 13-2-1 | Set destination address to the original destination address. | 12 |
| 13-2-2 | Discard the SMS_DestinationAddress, if any. | 13 |
| 13-2-3 | Include the SMS_DestinationAddress parameter set to the destination address. | 14 |
| 13-2-4 | IF the designation address is not for the current functional entity: | 15 |
| | | 16 |
| 13-2-4-1 | GOTO Route the message. | 17 |
| | | 18 |
| 13-2-5 | ELSE: | 19 |
| | | 20 |
| 13-2-5-1 | Include the SMS_CauseCode parameter set to <i>Address translation failure</i> . | 21 |
| 13-2-5-2 | Send a RETURN RESULT to the sender of the INVOKE. | 22 |
| 13-2-5-3 | Exit this task. | 23 |
| | | 24 |
| 13-2-6 | ENDIF. | 25 |
| 13-3 | ENDIF. | 26 |
| | | 27 |
| 14 | ELSEIF the destination address type is for one of the current interfaced networks: | 28 |
| 14-1 | IF multiple networks of the destination address type are available: | 29 |
| | | 30 |
| 14-1-1 | Select the destination network based on the destination address and destination address type. | 31 |
| | | 32 |
| 14-2 | ELSE: | 33 |
| | | 34 |
| 14-2-1 | Select the indicated network based on the destination address type. | 35 |
| | | 36 |
| 14-3 | ENDIF. | 37 |
| 14-4 | IF the address is not known or is not supported: | 38 |
| | | 39 |
| 14-4-1 | Discard the message. | 40 |
| 14-4-2 | Include the SMS_CauseCode parameter set to <i>Address translation failure</i> . | 41 |
| 14-4-3 | Send a RETURN RESULT to the sender of the INVOKE. | 42 |
| 14-4-4 | Exit this task. | 43 |
| | | 44 |
| 14-5 | ENDIF. | 45 |
| 15 | ELSEIF another router is known for the indicated address type: | 46 |
| 15-1 | IF multiple routers are available: | 47 |
| | | 48 |
| 15-1-1 | Select the router based upon the destination address and destination address type. | 49 |
| | | 50 |
| 15-2 | ELSE: | 51 |
| | | 52 |
| 15-2-1 | Select the router based upon the destination address type. | 53 |
| | | 54 |
| 15-3 | ENDIF. | 55 |
| 15-4 | Select the network and destination address based upon the selected router. | 56 |
| 16 | ELSE (address type is not supported): | 57 |
| | | 58 |
| 16-1 | Discard the message. | 59 |
| | | 60 |

- 1 16-2 Include the SMS_CauseCode parameter set to *Address translation failure*.
 2 16-3 Send a RETURN RESULT to the sender of the INVOKE.
 3
 4 16-4 Exit this task.
 5 17 ENDIF.
 6
 7 18 Relay all received parameters (except as modified above).
 8 19 Send the SMSDeliveryPointToPoint INVOKE message on the selected network toward
 9 the destination address.
 10
 11 20 Start the Short Message Timer (SMT).
 12 21 WAIT (for the message response):
 13 22 WHEN the response (RETURN RESULT, RETURN ERROR, or REJECT) has been
 14 received³:
 15
 16 22-1 Relay the response and all parameters to the sender of the INVOKE.
 17 22-2 Stop the timer (SMT).
 18 22-3 Discard the any context.
 19
 20 23 WHEN the timer (SMT) expires:
 21 23-1 Include the SMS_CauseCode parameter set to *Network failure*.
 22 23-2 Send a RETURN RESULT to the sender of the INVOKE.
 23 23-3 Discard any context.
 24
 25 24 ENDWAIT.
 26
 27 25 Exit this task.
 28
 29

30 4.47 SMS NOTIFICATION

31 4.47.1 HLR Initiating SMSNotification INVOKE

32 Upon request to send an SMSNotification message, the HLR shall do the following:

- 33
 34 1 Include the ElectronicSerialNumber parameter set to the ESN of the desired MS.
 35 2 Include the MobileIdentificationNumber parameter set to the MIN of the desired MS.
 36 3 IF MS is denied:
 37 3-1 Include the SMS_AccessDeniedReason parameter set to *Denied*.
 38 4 ELSEIF MS is unavailable or the temporary SMS routing address is not current:
 39 4-1 Include the SMS_AccessDeniedReason parameter set to *Unavailable*.
 40 45 5 ELSE:
 41 46 5-1 Include the SMS_Address parameter set to the temporary SMS routing address for
 42 the desired MS.
 43 44 6 ENDIF.
 45 46 7 Send a SMSNotification message toward the MS's MC.
 47 48 8 Start the SMS Notification Timer (SNT).
 49
 50
 51
 52
 53
 54

55 ³The sending of an SMS DeliveryPointToPoint RETURN ERROR is not recommended and
 56 error tables are not supplied.
 57
 58
 59
 60

- 9 WAIT for a SMS Notification response:
- 10 WHEN a RETURN RESULT is received:
 - 10-1 Stop the timer (SNT).
 - 10-2 IF the message cannot be processed:
 - 10-2-1 Execute “Local Recovery Procedures” task (see 3.5.1).
 - 10-3 ENDIF.
- 11 WHEN a RETURN ERROR or REJECT is received:
 - 11-1 Stop the timer (SNT).
 - 11-2 Execute “Local Recovery Procedures” task (see 3.5.1).
- 12 WHEN the timer (SNT) expires:
 - 12-1 Execute “Local Recovery Procedures” task (see 3.5.1).
- 13 ENDWAIT.
- 14 Exit this task.

4.47.2 MSC Initiating SMS Notification

If the availability status of an MS-based SME changes (e.g., when an MS does a sleep mode wake-up registration) while the SMS Delivery Pending Flag is set, the MSC shall do the following:

- 1 Include the ElectronicSerialNumber parameter set to the ESN of the desired MS.
- 2 Include the MobileIdentificationNumber parameter set to the MIN of the desired MS.
- 3 IF MS is denied:
 - 3-1 Include the SMS_AccessDeniedReason parameter set to *Denied*.
- 4 ELSEIF the MS is unavailable:
 - 4-1 Include the SMS_AccessDeniedReason parameter set to *Unavailable*.
- 5 ELSE:
 - 5-1 Include the SMS_Address parameter set to the temporary SMS routing address for the desired MS. (The MSC should also do what is necessary to keep the MS awake for some period of time for a possible short message delivery.)
- 6 ENDIF.
- 7 Send a SMSNotification message toward the MS’s MC.
- 8 Start the SMS Notification Timer (SNT).
- 9 WAIT for a SMS Notification response:
- 10 WHEN a RETURN RESULT is received:
 - 10-1 Stop the timer (SNT).
 - 10-2 IF the message cannot be processed:
 - 10-2-1 Execute “Local Recovery Procedures” task (see 3.5.1).
 - 10-3 ENDIF.
- 11 WHEN a RETURN ERROR or REJECT is received:
 - 11-1 Stop the timer (SNT).
 - 11-2 Execute “Local Recovery Procedures ” task (see 3.5.1).
- 12 WHEN the timer (SNT) expires:

- 12-1 Execute “Local Recovery Procedures ” task (see 3.5.1).
- 13 ENDWAIT.
- 14 Exit this task.

4.47.3 MC Receiving an SMSNotification INVOKE

Upon receipt of a SMSNotification INVOKE, the MC shall do the following::

- 1 IF the received message can be processed:
 - 1-1 Select the MS based on the received MobileIdentificationNumber and ElectronicSerialNumber parameters.
 - 1-2 IF the SMS_AccessDeniedReason parameter was received:
 - 1-2-1 Clear the SMS_Address.
 - 1-3 ELSEIF the SMS_Address parameter was received:
 - 1-3-1 Store the SMS_Address as the temporary routing address with the current time.
 - 1-4 ELSE (expected parameters not received):
 - 1-4-1 Send a RETURN ERROR with the Error Code set to *MissingParameter*.
 - 1-4-2 Exit this task.
 - 1-5 ENDIF.
 - 1-6 Send a SMSNotification RETURN RESULT.
 - 1-7 IF messages are queued for delivery to the indicated MIN:
 - 1-7-1 Pass SMSNotification to “MC Initiating SMS Delivery Point-To-Point to anMS-Based SME” task (see 4.46.9 “Wait for Notification”).
 - 1-8 ELSE:
 - 1-8-1 Ignore the message.
 - 1-9 ENDIF.
- 2 ELSE (the received message cannot be processed):
 - 2-1 Send a RETURN ERROR with the proper Error Code value (see the following table).
- 3 ENDIF.
- 4 Exit this task.

Table 56 MC SMSNotification Response

| Problem Detection and Recommended Response
from the MC toward the initiating HLR | | | | | | | | | | | | |
|---|---|---|---|---|---|---|---|---|---|----|----|-------|
| PROBLEM DETECTION | 1 | 2 | 3 | 4 | 5 | 6 | 7 | 8 | 9 | 10 | 11 | Notes |
| RETURN ERROR
Error Code | | | | | | | | | | | | |
| <i>UnrecognizedMIN</i> | | | | | | | | X | | | | |
| <i>UnrecognizedESN</i> | | | | | | | | | X | | | |
| <i>MIN/HLRMismatch</i> | | | | | | | X | | | | | |
| <i>OperationSequenceProblem</i> | | | | | | | | | | | | a |
| <i>ResourceShortage</i> | | X | | | | | | | | | | |
| <i>OperationNotSupported</i> | X | | | | | | | | | | | b, e |
| <i>TrunkUnavailable</i> | | | | | | | | | | | | a |
| <i>ParameterError</i> | | | | X | | | | | | | | d |
| <i>SystemFailure</i> | | | X | | | | | | | | | e |
| <i>UnrecognizedParameterValue</i> | | | | | X | | | | | | | d |
| <i>FeatureInactive</i> | | | | | | | | | | | | a |
| <i>MissingParameter</i> | | | | | | X | | | | | | d |
| RETURN RESULT | | | | | | | | | | X | X | c |

Problem Detections:

1. The requested MAP operation is recognized, but not supported, by the receiving MC, or the requesting functional entity is not authorized.
2. A required MC resource (e.g., internal memory record, MC is fully occupied) is temporarily not available (e.g., congestion).
3. A required resource (e.g., data base access, functional entity) is not presently accessible due to a failure. Human intervention may be required for resolution.
4. A supplied parameter has an encoding problem (e.g., the supplied MobileIdentificationNumber parameter digit values do not meet the BCD specification).
5. A supplied parameter value is unrecognized or has nonstandard values (e.g., *Not used*).
6. An expected, or required, optional parameter (e.g., SMS_AccessDeniedReason, SMS_Address) was not received.
7. The supplied MobileIdentificationNumber parameter is not in the MC's range of MINs (suspect routing error).
8. The supplied MobileIdentificationNumber parameter is in the MC's range of MINs, but no record exists for the MIN.
9. An MC record exists for the supplied MobileIdentificationNumber parameter, but the supplied ElectronicSerialNumber parameter does not match the ESN in the MC's record (if the MC stores it).
10. An MC record exists for the supplied MobileIdentificationNumber parameter, but a SMS routing address to the supplied MIN has been permanently denied (e.g., *Delinquent Account, Stolen Unit, Duplicate Unit, Invalid ESN, Unassigned directory number, Vacation disconnect*).

Notes:

- a. This Error Code is not an appropriate MC response to a SMSNotification transaction.
- b. It is recommended that an MC supports SMSNotification transactions.
- c. Only RETURN RESULT operations needing clarification have been included.
- d. Include the *Parameter Identifier* in question as the FaultyParameter parameter.

4.48 SMS REQUEST

4.48.1 MC Initiating SMS Request

Upon request to obtain a routing address for an MS-based SME (this request may be *accepted, postponed, unavailable, or denied*), the MC shall do the following:

- 1 IF the ESN is known for the MS:
 - 1-1 Include the ElectronicSerialNumber parameter set to identify the MS.
- 2 ENDIF.
- 3 Include the MobileIdentificationNumber parameter set to identify the MS.
- 4 Include the SMS_TeleserviceIdentifier parameter set to the appropriate teleservice identifier value if applicable.
- 5 IF notification is not required:
 - 5-1 Include the SMS_NotificationIndicator parameter set to *Do not notify whenavailable*.
- 6 ENDIF.
- 7 Send a SMSRequest INVOKE message toward the HLR serving the MIN.
- 8 Start the SMS Request Timer (SRT).
- 9 WAIT for an SMS Request response:
- 10 WHEN a RETURN RESULT is received:
 - 10-1 Stop the timer (SRT).
 - 10-2 IF the message can be processed:
 - 10-2-1 IF an SMS_Address is received:
 - 10-2-1-1 Return to the calling task with the SMS_Address and an *accepted* indication.
 - 10-2-2 ELSEIF an SMS_AccessDeniedReason parameter is received:
 - 10-2-2-1 CASE SMS_AccessDeniedReason value OF:
 - 10-2-2-2 *Postponed*:
 - 10-2-2-2-1 Return to the calling task with a *postponed* indication.
 - 10-2-2-3 *Denied*:
 - 10-2-2-3-1 Return to the calling task with a *denied* indication.
 - 10-2-2-4 *Unavailable*:
 - 10-2-2-4-1 Return to the calling task with a *unavailable* indication.
 - 10-2-2-5 ENDCASE:
 - 10-2-3 ENDIF.
 - 10-3 ELSE (the message cannot be processed):
 - 10-3-1 Return to the calling task with a *denied* indication.
 - 10-4 ENDIF.
 - 11 WHEN a RETURN ERROR or REJECT is received:
 - 11-1 Stop the timer (SRT).

- 11-2 Return to the calling task with a *denied* indication.
- 12 WHEN the timer (SRT) expires:
 - 12-1 Return to the calling task with a *denied* indication.
- 13 ENDWAIT.
- 14 Exit this task.

1
2
3
4
5
6
7
8
9
10
11
12
13
14
15
16
17
18
19
20
21
22
23
24
25
26
27
28
29
30
31
32
33
34
35
36
37
38
39
40
41
42
43
44
45
46
47
48
49
50
51
52
53
54
55
56
57
58
59
60

4.48.2 HLR Receiving an SMSRequest INVOKE

Upon receipt of a SMSRequest INVOKE, the HLR shall do the following:

- 1 IF the message can be processed:
 - 1-1 IF the addressed MS is not known, OR IF the MS is known, but is not authorized for SMS:
 - 1-1-1 Include the SMS_AccessDeniedReason parameter indicating *Denied*.
 - 1-2 ELSEIF (the teleservice indicated by the SMS_TeleserviceIdentifier parameter is unknown or is not supported):
 - 1-2-1 Include the SMS_AccessDeniedReason parameter indicating *Invalid*:
 - 1-3 ELSEIF the temporary SMS routing address is current (as determined by the HLR, e.g., some time between never to until revoked) for the addressed MS:
 - 1-3-1 Include the SMS_Address parameter set to the current SMS address for the MS.
 - 1-3-2 IF the ElectronicSerialNumber parameter was not received:
 - 1-3-2-1 Include the ElectronicSerialNumber parameter set to identify the MS.
 - 1-3-3 ENDIF.
 - 1-4 ELSEIF the addressed MS is able to receive SMS messages (e.g., MS is registered to an SMS capable system), but the SMS address is not current or the MS is reported as inactive:
 - 1-4-1 Relay all parameters received in the SMSRequest INVOKE.
 - 1-4-2 Include the ElectronicSerialNumber parameter for the addressed MS.
 - 1-4-3 Send an SMSRequest INVOKE to the VLR that is currently serving the indicated MS.
 - 1-4-4 Start the SMS Request Timer (SRT).
 - 1-4-5 WAIT for an SMS Request Response.
 - 1-4-6 WHEN a RETURN RESULT is received:
 - 1-4-6-1 Stop timer (SRT).
 - 1-4-6-2 IF the message can be processed:
 - 1-4-6-2-1 Relay all received parameters.
 - 1-4-6-3 ELSE (message cannot be processed):
 - 1-4-6-3-1 Execute "Local Recovery Procedures" task (see 3.5.1).
 - 1-4-6-3-2 Set the SMS Delivery Pending Flag for this MS.
 - 1-4-6-3-3 Include the SMS_AccessDeniedReason parameter set to *Postponed*.
 - 1-4-6-4 ENDIF.
 - 1-4-7 WHEN a RETURN ERROR or REJECT is received:
 - 1-4-7-1 Stop timer (SRT).

1
2
3
4
5
6
7
8
9
10
11
12
13
14
15
16
17
18
19
20
21
22
23
24
25
26
27
28
29
30
31
32
33
34
35
36
37
38
39
40
41
42
43
44
45
46
47
48
49
50
51
52
53
54
55
56
57
58
59
60

1-4-7-2 Execute “Local Recovery Procedures” task (see 3.5.1).

1-4-7-3 Set the SMS Delivery Pending Flag for this MS.

1-4-7-4 Include the SMS_AccessDeniedReason parameter set to *Postponed*.

1-4-8 WHEN timer (SRT) expires:

1-4-8-1 Execute “Local Recovery Procedures” task (see 3.5.1).

1-4-8-2 Set the SMS Delivery Pending Flag for this MS.

1-4-8-3 Include the SMS_AccessDeniedReason parameter set to *Postponed*.

1-4-9 ENDWAIT.

1-5 ELSE (the MS is not registered to an SMS capable system or the MS is registered to an SMS incapable system):

1-5-1 IF the SMS_NotificationIndicator parameter was present in the SMSRequest INVOKE and the SMS_NotificationIndicator indicates *Do not notify when available*:

1-5-1-1 Include the SMS_AccessDeniedReason parameter set to *Unavailable*.

1-5-2 ELSE:

1-5-2-1 Set the *SMS Delivery Pending Flag* for this MS.

1-5-2-2 Include the SMS_AccessDeniedReason parameter set to *Postponed*.

1-5-3 ENDIF.

1-6 ENDIF.

1-7 Send a RETURN RESULT.

2 ELSE (message cannot be processed):

2-1 Include the Error Code parameter set to the proper value (see the following table).

2-2 Send a RETURN ERROR.

3 ENDIF.

4 Exit this task.

Table 57 HLR SMSRequest Response

| Problem Detection and Recommended Response
from the HLR toward the requesting MC | | | | | | | | | | | | | | |
|---|---|---|---|---|---|---|---|---|---|----|----|----|----|-------|
| PROBLEM DETECTION | 1 | 2 | 3 | 4 | 5 | 6 | 7 | 8 | 9 | 10 | 11 | 12 | 13 | Notes |
| RETURN ERROR
Error Code | | | | | | | | | | | | | | |
| <i>UnrecognizedMIN</i> | | | | | | | | X | | | | | | |
| <i>UnrecognizedESN</i> | | | | | | | | | X | | | | | |
| <i>MIN/HLRMismatch</i> | | | | | | | X | | | | | | | |
| <i>OperationSequenceProblem</i> | | | | | | | | | | | | | | a |
| <i>ResourceShortage</i> | | X | | | | | | | | | | | | |
| <i>OperationNotSupported</i> | X | | | | | | | | | | | | | b, e |
| <i>TrunkUnavailable</i> | | | | | | | | | | | | | | a |
| <i>ParameterError</i> | | | | X | | | | | | | | | | d |
| <i>SystemFailure</i> | | | X | | | | | | | | | | | e |
| <i>UnrecognizedParameterValue</i> | | | | | X | | | | | | | | | d |
| <i>FeatureInactive</i> | | | | | | | | | | | | | | a |
| <i>MissingParameter</i> | | | | | | X | | | | | | | | d |
| RETURN RESULT
SMS_AccessDeniedReason | | | | | | | | | | | | | | c |
| <i>Denied</i> | | | | | | | | | X | | | | | |
| <i>Postponed</i> | | | | | | | | | | X | | | | |
| <i>Unavailable</i> | | | | | | | | | | | X | | | |
| <i>Invalid</i> | | | | | | | | | | | | X | | |

Problem Detections:

1. The requested MAP operation is recognized, but not supported, by the receiving HLR, or the requesting functional entity is not authorized.
2. A required HLR resource (e.g., internal memory record, HLR is fully occupied) is temporarily not available (e.g., congestion).
3. A required resource (e.g., data base access, functional entity) is not presently accessible due to a failure. Human intervention may be required for resolution.
4. A supplied parameter has an encoding problem (e.g., the supplied MobileIdentificationNumber parameter digit values do not meet the BCD specification).
5. A supplied parameter value is unrecognized or has nonstandard values (e.g., *Not used*).
6. An expected, or required, optional parameter (e.g., SMS_NotificationIndicator) was not received. The HLR has activity for the supplied MobileIdentificationNumber parameter that requires the ElectronicSerialNumber parameter to be supplied before a SMSRequest transaction can be successfully completed, the ElectronicSerialNumber parameter was not supplied.
7. The supplied MobileIdentificationNumber parameter is not in the HLR's range of MINs or directory numbers (suspect routing error).
8. The supplied MobileIdentificationNumber parameter is within the HLR's range of MINs, but no record exists.
9. An HLR record exists for the supplied MobileIdentificationNumber parameter, but the ElectronicSerialNumber parameter supplied does not match the stored value.
10. An HLR record exists for the supplied MobileIdentificationNumber parameter, but a SMS routing address to the supplied MIN has been permanently denied (e.g., *Delinquent Account, Stolen Unit, Duplicate Unit, Invalid ESN, Unassigned directory number, Vacation disconnect*); avoid future SMS transactions to the supplied MIN (ESN).
11. An HLR record exists for the supplied MobileIdentificationNumber parameter, but a SMS routing address to the supplied MIN has been temporarily denied (e.g., no routing address, MS is busy, MS

1 is not registered, No Page Response, MS is unavailable, MS is inactive, other temporary SMS
 2 delivery trouble). Also when the Serving VLR (or other functional entity) responded
 3 *OperationNotSupported* or did not respond. The HLR will notify the requesting MC when SMS
 4 delivery to the supplied MIN can be resumed.

5
 6 12. An HLR record exists for the supplied MobileIdentificationNumber parameter, but a SMS routing
 7 address to the supplied MIN has been temporarily denied (e.g., no routing address, MS is busy, MS
 8 is not registered, No Page Response, MS is unavailable, MS is inactive, other temporary SMS
 9 delivery trouble). Also when the Serving VLR (or other functional entity) responded
 10 *OperationNotSupported* or did not respond. The HLR will not notify the requesting MC when SMS
 11 delivery to the supplied MIN can be resumed.

12 13. The teleservice indicated by the SMS_TeleserviceIdentifier parameter is unknown or is not
 13 supported.

14
 15 Notes:

- 16 a. This Error Code is not an appropriate HLR response to a SMSRequest transaction.
 17 b. It is recommended that a HLR supports SMSRequest transactions.
 18 c. Only RETURN RESULT operations needing clarification have been included.
 19 d. Include the *Parameter Identifier* in question as the FaultyParameter parameter.
 20
 21

22
 23 **4.48.3 VLR Receiving an SMSRequest INVOKE**

24 Upon receipt of an SMSRequest INVOKE, the VLR shall perform the following:

- 25 1 IF the received message can be processed:
 26
 27 1-1 Relay all received parameters.
 28
 29 1-2 Send a SMSRequest INVOKE to the MSC that is currently serving the indicated
 30 MS.
 31
 32 1-3 Start the SMS Request Timer (SRT).
 33
 34 1-4 WAIT for a SMS Request Response.
 35
 36 1-5 WHEN a RETURN RESULT is received:
 37 1-5-1 Stop timer (SRT).
 38 1-5-2 IF the message is valid:
 39 1-5-2-1 Relay all received parameters.
 40 1-5-2-2 Send a RETURN RESULT to the HLR.
 41 1-5-3 ELSE (message is not valid):
 42 1-5-3-1 Send a RETURN ERROR with Error Code .
 43 1-5-3-2 Execute "Local Recovery Procedures" task (see 3.5.1).
 44 1-5-4 ENDIF.
 45
 46 1-6 WHEN a RETURN ERROR or REJECT is received:
 47 1-6-1 Stop timer (SRT).
 48 1-6-2 CASE Error Code OF:
 49 1-6-3 *ParameterError*:
 50 1-6-3-1 Send a RETURN ERROR with Error Code *ParameterError*.
 51 1-6-4 *OperationSequenceProblem*:
 52 1-6-4-1 Send a RETURN ERROR with Error Code *OperationSequenceProblem*.
 53 1-6-5 *DEFAULT*:
 54
 55
 56
 57
 58
 59
 60

- 1-6-5-1 Send a RETURN ERROR with Error Code *SystemFailure..*
- 1-6-6 ENDCASE.
- 1-6-7 Execute “Local Recovery Procedures ” task (see 3.5.1).
- 1-7 WHEN timer (SRT) expires:
 - 1-7-1 Send a RETURN ERROR with Error Code *SystemFailure.*
 - 1-7-2 Execute “Local Recovery Procedures ” task (see 3.5.1).
- 1-8 ENDWAIT.
- 2 ELSE (the received message cannot be processed):
 - 2-1 Send a RETURN ERROR with the proper Error Code value (see the following table).
- 3 ENDIF.
- 4 Exit this task.

Table 58 VLR SMSRequest Response

| Problem Detection and Recommended Response from the VLR to the requesting HLR | | | | | | | | | | | | |
|---|---|---|---|---|---|---|---|---|---|----|----|-------|
| PROBLEM DETECTION | 1 | 2 | 3 | 4 | 5 | 6 | 7 | 8 | 9 | 10 | 11 | Notes |
| RETURN ERROR | | | | | | | | | | | | |
| Error Code | | | | | | | | | | | | |
| <i>UnrecognizedMIN</i> | | | | | | | X | | | | | |
| <i>UnrecognizedESN</i> | | | | | | | | X | | | | |
| <i>MIN/HLRMismatch</i> | | | | | | | | | | | | a |
| <i>OperationSequenceProblem</i> | | | | | | | | | | | | a |
| <i>ResourceShortage</i> | | X | | | | | | | | | | |
| <i>OperationNotSupported</i> | X | | | | | | | | | | | b, e |
| <i>TrunkUnavailable</i> | | | | | | | | | | | | a |
| <i>ParameterError</i> | | | | X | | | | | | | | d |
| <i>SystemFailure</i> | | | X | | | | | | | | | e |
| <i>UnrecognizedParameterValue</i> | | | | | X | | | | | | | d |
| <i>FeatureInactive</i> | | | | | | | | | | | | a |
| <i>MissingParameter</i> | | | | | | X | | | | | | d |
| RETURN RESULT | | | | | | | | | | | | c |
| SMS_AccessDeniedReason | | | | | | | | | | | | |
| <i>Denied</i> | | | | | | | | | X | | | |
| <i>Postponed</i> | | | | | | | | | | X | | |
| <i>Unavailable</i> | | | | | | | | | | | X | |

Problem Detections:

1. The requested MAP operation is recognized, but not supported, by the receiving VLR, or the requesting functional entity is not authorized.
2. A required VLR resource (e.g., internal memory record, VLR is fully occupied) is temporarily not available (e.g., congestion).
3. A required resource (e.g., data base access, functional entity) is not presently accessible due to a failure. Human intervention may be required for resolution.
4. A supplied parameter has an encoding problem (e.g., the supplied MobileIdentificationNumber parameter digit values do not meet the BCD specification).
5. A supplied parameter value is unrecognized or has nonstandard values (e.g., *Not used*).

1
2
3
4
5
6
7
8
9
10
11
12
13
14
15
16
17
18
19
20
21
22
23
24
25
26
27
28
29
30
31
32
33
34
35
36
37
38
39
40
41
42
43
44
45
46
47
48
49
50
51
52
53
54
55
56
57
58
59
60

6. An expected, or required, optional parameter (e.g., `ElectronicSerialNumber`, `SMS_NotificationIndicator`) was not received.
7. A VLR record does not presently exist for the supplied `MobileIdentificationNumber` parameter. (The HLR should remove its pointer to the VLR.)
8. A VLR record exists for the supplied `MobileIdentificationNumber` parameter, but the supplied parameter does not match the stored value.
9. A VLR record exists for the supplied `MobileIdentificationNumber` parameter, but a SMS routing address to the supplied MIN is permanently denied (e.g., *Delinquent Account*, *Stolen Unit*, *Duplicate Unit*, *Invalid ESN*, *Unassigned directory number*, *Vacation disconnect*); avoid future SMS transactions to the supplied MIN (ESN).
10. A VLR record exists for the supplied `MobileIdentificationNumber` parameter, but a SMS routing address to the supplied MIN has been temporarily denied (e.g., no routing address, MS is busy, MS is not registered, no page response, MS is unavailable, MS is inactive, other temporary SMS delivery trouble). Also when the Serving MSC (or other functional entity) responded *OperationNotSupported* or did not respond. The VLR will notify the requesting HLR when SMS delivery to the supplied MIN can be resumed.
11. A VLR record exists for the supplied `MobileIdentificationNumber` parameter, but a SMS routing address to the supplied MIN has been temporarily denied (e.g., no routing address, MS is busy, MS is not registered, No Page Response, MS is unavailable, MS is inactive, other temporary SMS delivery trouble). Also when the Serving MSC (or other functional entity) responded *OperationNotSupported* or did not respond. The VLR will not notify the requesting HLR when SMS delivery to the supplied MIN can be resumed.

Notes:

- a. This Error Code is not an appropriate VLR response to a `SMSRequest` transaction.
- b. It is recommended that a VLR supports `SMSRequest` transactions.
- c. Only RETURN RESULT operations needing clarification have been included.
- d. Include the *Parameter Identifier* in question as the `FaultyParameter` parameter.

4.48.4 MSC Receiving an SMSRequest INVOKE

Upon receipt of an `SMSRequest INVOKE`, the MSC shall perform the following:

- 1 IF the received message can be processed:
 - 1-1 IF the MSC is not capable of supporting SMS:
 - 1-1-1 Include the `SMS_AccessDeniedReason` parameter set to *Unavailable*.
 - 1-2 ELSEIF the MS is not capable or authorized for SMS:
 - 1-2-1 Include the `SMS_AccessDeniedReason` parameter set to *Denied*.
 - 1-3 ELSEIF the MS is in a state, operation mode, and location where it can receive SMS messages.
 - 1-3-1 Optionally, take action to keep the MS in a mode capable of receiving SMS messages.
 - 1-3-2 Include the `SMS_Address` parameter set to reflect the address to be used to deliver SMS messages for the indicated MS.
 - 1-4 ELSE (MS can receive SMS messages, but not right now):
 - 1-4-1 IF the `SMS_NotificationIndicator` parameter was received and the `SMS_NotificationIndicator` indicates *Do not notify when available*:
 - 1-4-1-1 Include the `SMS_AccessDeniedReason` parameter set to *Unavailable*.
 - 1-4-2 ELSE (notification was requested):

- 1-4-2-1 Set the *SMS Delivery Pending Flag* for this MS.
- 1-4-2-2 Include the *SMS_AccessDeniedReason* parameter set to *Postponed*.
- 1-4-3 ENDIF.
- 1-5 ENDIF.
- 1-6 Send a RETURN RESULT to the requesting VLR.
- 2 ELSE (the received message cannot be processed):
- 2-1 Send a RETURN ERROR with the proper Error Code value (see the following table).
- 3 ENDIF.
- 4 Exit this task.

Table 59 MSC SMSRequest Response

| Problem Detection and Recommended Response from the MSC to the requesting VLR | | | | | | | | | | | | |
|---|---|---|---|---|---|---|---|---|---|----|----|-------|
| PROBLEM DETECTION | 1 | 2 | 3 | 4 | 5 | 6 | 7 | 8 | 9 | 10 | 11 | Notes |
| RETURN ERROR | | | | | | | | | | | | |
| Error Code | | | | | | | | | | | | |
| <i>UnrecognizedMIN</i> | | | | | | | X | | | | | |
| <i>UnrecognizedESN</i> | | | | | | | | X | | | | |
| <i>MIN/HLRMismatch</i> | | | | | | | | | | | | a |
| <i>OperationSequenceProblem</i> | | | | | | | | | | | | a |
| <i>ResourceShortage</i> | | X | | | | | | | | | | |
| <i>OperationNotSupported</i> | X | | | | | | | | | | | b, e |
| <i>TrunkUnavailable</i> | | | | | | | | | | | | a |
| <i>ParameterError</i> | | | | X | | | | | | | | d |
| <i>ParameterError</i> | | | X | | | | | | | | | e |
| <i>UnrecognizedParameterValue</i> | | | | | X | | | | | | | d |
| <i>FeatureInactive</i> | | | | | | | | | | | | a |
| <i>MissingParameter</i> | | | | | | X | | | | | | d |
| RETURN RESULT | | | | | | | | | | | | c |
| SMS_AccessDeniedReason | | | | | | | | | | | | |
| <i>Denied</i> | | | | | | | | | X | | | |
| <i>Postponed</i> | | | | | | | | | | X | | |
| <i>Unavailable</i> | | | | | | | | | | | X | |

Problem Detections:

1. The requested MAP operation is recognized, but not supported, by the receiving MSC, or the requesting functional entity is not authorized.
2. A required MSC resource (e.g., internal memory record, HLR is fully occupied) is temporarily not available (e.g., congestion).
3. A required resource (e.g., data base access, functional entity) is not presently accessible due to a failure. Human intervention may be required for resolution.
4. A supplied parameter has an encoding problem (e.g., the supplied MobileIdentificationNumber parameter digit values do not meet the BCD specification).
5. A supplied parameter value is unrecognized or has nonstandard values (e.g., *Not used*).
6. An expected, or required, optional parameter (e.g., ElectronicSerialNumber, SMS_NotificationIndicator) was not received.

1
2
3
4
5
6
7
8
9
10
11
12
13
14
15
16
17
18
19
20
21
22
23
24
25
26
27
28
29
30
31
32
33
34
35
36
37
38
39
40
41
42
43
44
45
46
47
48
49
50
51
52
53
54
55
56
57
58
59
60

7. The MSC does not presently have a record for the supplied MobileIdentificationNumber parameter. (The VLR should remove its pointer to the MSC.)
8. An MSC record exists for the supplied MobileIdentificationNumber parameter, but the supplied ElectronicSerialNumber parameter does not match the stored value.
9. An MSC record exists for the supplied MobileIdentificationNumber parameter, but a SMS routing address to the supplied MIN has been permanently denied (e.g., *Delinquent Account, Stolen Unit, Duplicate Unit, Invalid ESN, Unassigned directory number, Vacation disconnect*); avoid future SMS transactions to the supplied MIN.
10. An MSC record exists for the supplied MobileIdentificationNumber parameter, but a SMS routing address to the supplied MIN has been temporarily denied (e.g., no routing address, MS is busy, MS is not registered, No Page Response, MS is unavailable, MS is inactive, other temporary SMS delivery trouble). The MSC will notify the VLR when SMS delivery to the supplied MIN can be resumed.
11. An MSC record exists for the supplied MobileIdentificationNumber parameter, but a SMS routing address to the supplied MIN has been temporarily denied (e.g., no routing address, MS is busy, MS is not registered, No Page Response, MS is unavailable, MS is inactive, other temporary SMS delivery trouble). The MSC will not notify the VLR when SMS delivery to the supplied MIN can be resumed.

Notes:

- a. This Error Code is not an appropriate MSC response to a SMSRequest transaction.
- b. It is recommended that an MSCs support SMSRequest transactions.
- c. Only RETURN RESULT operations needing clarification have been included.
- d. Include the *Parameter Identifier* in question as the FaultyParameter parameter.

4.49 TRANSFER-TO-NUMBER REQUEST

4.49.1 MSC Initiating a Transfer-To-Number Request

When an MSC detects that it needs to request the transfer-to-number associated with an MS, it shall perform the following:

- 1 Relay the RedirectionReason parameter set by the calling task.
- 2 Include the CallingPartyNumberDigits1 parameter.
- 3 Include the CallingPartySubaddress parameter.
- 4 Include the MS's ElectronicSerialNumber parameter.
- 5 Include the MS's MobileIdentificationNumber parameter.
- 6 Include the MSC's MSCIdentificationNumber.
- 7 Include the MSC's SystemMyTypeCode parameter.
- 8 Include the TransactionCapability parameter set according to the capabilities of the system and the current call state.
- 9 IF the MSC is the Originating MSC:
 - 9-1 Include the Originating MSC's call's BillingID parameter to identify the call for subsequent call redirection.
- 10 ELSEIF the MSC is the Serving MSC:
 - 10-1 Include the Serving MSC's BillingID parameter to identify the call for subsequent call redirection.
- 11 ENDIF.

| | | |
|------------|--|----|
| 12 | IF the leg was established with a PilotBillingID parameter: | 1 |
| 12-1 | Include the PilotBillingID parameter set to the same value as received. | 2 |
| 13 | ENDIF. | 3 |
| 14 | Send a TransferToNumberRequest INVOKE to the MS's HLR. | 4 |
| 15 | Start the Transfer-To-Number Request Timer (TTNRT). | 5 |
| 16 | WAIT for a Transfer to Number Request response: | 6 |
| 17 | WHEN a RETURN RESULT is received: | 7 |
| 17-1 | Stop timer (TTNRT). | 8 |
| 17-2 | IF the message can be processed: | 9 |
| 17-2-1 | IF the AnnouncementList parameter is received: | 10 |
| 17-2-1-1 | Execute the "Play All Announcements in the AnnouncementList" task (see 3.2.5). | 11 |
| 17-2-2 | ENDIF. | 12 |
| 17-2-3 | IF an ActionCode parameter is received: | 13 |
| 17-2-3-1 | Execute the "MSC ActionCode Processing" task (see 3.2.9). | 14 |
| 17-2-4 | ENDIF. | 15 |
| 17-2-5 | IF the AccessDeniedReason parameter is received: | 16 |
| 17-2-5-1 | IF AnnouncementList parameter was not received: | 17 |
| 17-2-5-1-1 | Apply the treatment appropriate to the returned AccessDeniedReason value. | 18 |
| 17-2-5-2 | ENDIF. | 19 |
| 17-2-5-3 | Return to the calling task with a <i>successful</i> indication. | 20 |
| 17-2-6 | ENDIF. | 21 |
| 17-2-7 | IF the TerminationList parameter is received: | 22 |
| 17-2-7-1 | Execute the "MSC Routing Points Of Return" task (see 3.2.6). | 23 |
| 17-2-7-2 | Return to the calling task with a <i>successful</i> indication. | 24 |
| 17-2-8 | ELSEIF the Digits (Destination) parameter is received: | 25 |
| 17-2-8-1 | Release all extended facilities associated with the indicated call. | 26 |
| 17-2-8-2 | Execute the "MSC Route the Call Leg Externally" task (see 3.3.8). | 27 |
| 17-2-8-3 | Return to the calling task with a <i>successful</i> indication. | 28 |
| 17-2-9 | ELSE: | 29 |
| 17-2-9-1 | Execute "Local Recovery Procedures" task (see 3.5.1). | 30 |
| 17-2-9-2 | Return to the calling task with an <i>unsuccessful</i> indication. | 31 |
| 17-2-10 | ENDIF. | 32 |
| 17-3 | ELSE (the message cannot be processed): | 33 |
| 17-3-1 | Execute "Local Recovery Procedures" task (see 3.5.1). | 34 |
| 17-3-2 | Return to the calling task with an <i>unsuccessful</i> indication. | 35 |
| 17-4 | ENDIF. | 36 |
| 18 | WHEN a RemoteUserInteractionDirective INVOKE is received: | 37 |
| 18-1 | Stop timer (TTNRT). | 38 |
| 18-2 | Execute the "MSC Remote User Interaction" task (see 4.39.2). | 39 |
| | | 40 |
| | | 41 |
| | | 42 |
| | | 43 |
| | | 44 |
| | | 45 |
| | | 46 |
| | | 47 |
| | | 48 |
| | | 49 |
| | | 50 |
| | | 51 |
| | | 52 |
| | | 53 |
| | | 54 |
| | | 55 |
| | | 56 |
| | | 57 |
| | | 58 |
| | | 59 |
| | | 60 |

- 1 18-3 Start the Transfer-To-Number Timer (TTNRT).
 2 18-4 Remain in this state.
 3
 4 19 WHEN the incoming call disconnects:
 5 19-1 Remain in this state (to handle possible call abandons).
 6 20 WHEN a RETURN ERROR or REJECT is received:
 7 20-1 Stop timer (TTNRT).
 8 20-2 Execute “Local Recovery Procedures” task (see 3.5.1).
 9 20-3 Return to the calling task with an *unsuccessful* indication.
 10 21 WHEN timer (RDRT) expires:
 11 21-1 Execute “Local Recovery Procedures” task (see 3.5.1).
 12 21-2 Return to the calling task with an *unsuccessful* indication.
 13 22 ENDWAIT.

19 4.49.2 HLR Receiving TransferToNumberRequest INVOKE

21 When an HLR receives a TransferToNumberRequest INVOKE, it shall perform the
 22 following:
 23

- 24 1 IF the received message can be processed:
 25 1-1 CASE RedirectionReason (to determine the feature processing and PointOfReturn)
 26 OF:
 27 1-2 *No Page Response* (This is the Page Failure PointOfDetection.):
 28 1-2-1 Execute the “HLR FA Unresponsive MS Invocation” task (see 5.12.8).
 29 1-2-2 IF the PointOfReturn is indicated:
 30 1-2-2-1 GOTO TraNumReqPointOfReturn.
 31 1-2-3 ENDIF.
 32 1-2-4 Execute the “HLR MAH Unresponsive MS Invocation” task (see 5.14.9).
 33 1-2-5 IF the PointOfReturn is indicated:
 34 1-2-5-1 GOTO TraNumReqPointOfReturn.
 35 1-2-6 ENDIF.
 36 1-2-7 Execute the “HLR CFNA Unresponsive MS Invocation” task (see 5.4.8).
 37 1-2-8 IF the PointOfReturn is indicated:
 38 1-2-8-1 GOTO TraNumReqPointOfReturn.
 39 1-2-9 ENDIF.
 40 1-2-10 Execute the “HLR CFD Unresponsive MS Invocation” task (see 5.3.8).
 41 1-2-11 IF the PointOfReturn is indicated:
 42 1-2-11-1 GOTO TraNumReqPointOfReturn.
 43 1-2-12 ENDIF.
 44 1-2-13 Include the AnnouncementCode parameter in the AnnouncementList
 45 parameter set to Reorder or other appropriate announcement.
 46 1-2-14 Relay the received AccessDeniedReason parameter.
 47 1-2-15 Set PointOfReturn to *ToneTermination*.
 48 1-3 (This is the Busy Failure PointOfDetection.):
 49
 50
 51
 52
 53
 54
 55
 56
 57
 58
 59
 60

| | | |
|----------|--|----|
| 1-3-1 | Execute the “HLR FA Busy MS Invocation” task (see 5.12.5). | 1 |
| 1-3-2 | IF the PointOfReturn is indicated: | 2 |
| 1-3-2-1 | GOTO TraNumReqPointOfReturn. | 3 |
| 1-3-3 | ENDIF. | 4 |
| 1-3-4 | Execute the “HLR MAH Busy MS Invocation” task (see 5.14.6). | 5 |
| 1-3-5 | IF the PointOfReturn is indicated: | 6 |
| 1-3-5-1 | GOTO TraNumReqPointOfReturn. | 7 |
| 1-3-6 | ENDIF. | 8 |
| 1-3-7 | Execute the “HLR CFB Busy MS Invocation” task (see 5.2.5). | 9 |
| 1-3-8 | IF the PointOfReturn is indicated: | 10 |
| 1-3-8-1 | GOTO TraNumReqPointOfReturn. | 11 |
| 1-3-9 | ENDIF. | 12 |
| 1-3-10 | Execute the “HLR CFD Busy MS Invocation” task (see 5.3.9). | 13 |
| 1-3-11 | IF the PointOfReturn is indicated: | 14 |
| 1-3-11-1 | GOTO TraNumReqPointOfReturn. | 15 |
| 1-3-12 | ENDIF. | 16 |
| 1-3-13 | Relay the received AccessDeniedReason parameter. | 17 |
| 1-3-14 | Set PointOfReturn to <i>ToneTermination</i> . | 18 |
| 1-4 | <i>No Answer</i> (This is the Answer Failure PointOfDetection.): | 19 |
| 1-4-1 | Execute the “HLR FA No Answer MS Invocation” task (see 5.12.9). | 20 |
| 1-4-2 | IF the PointOfReturn is indicated: | 21 |
| 1-4-2-1 | GOTO TraNumReqPointOfReturn. | 22 |
| 1-4-3 | ENDIF. | 23 |
| 1-4-4 | Execute the “HLR MAH No Answer MS Invocation” task (see 5.14.10). | 24 |
| 1-4-5 | IF the PointOfReturn is indicated: | 25 |
| 1-4-5-1 | GOTO TraNumReqPointOfReturn. | 26 |
| 1-4-6 | ENDIF. | 27 |
| 1-4-7 | Execute the “HLR CFNA No Answer MS Invocation” task (see 5.4.9). | 28 |
| 1-4-8 | IF the PointOfReturn is indicated: | 29 |
| 1-4-8-1 | GOTO TraNumReqPointOfReturn. | 30 |
| 1-4-9 | ENDIF. | 31 |
| 1-4-10 | Execute the “HLR CFD No Answer MS Invocation” task (see 5.3.10). | 32 |
| 1-4-11 | IF the PointOfReturn is indicated: | 33 |
| 1-4-11-1 | GOTO TraNumReqPointOfReturn. | 34 |
| 1-4-12 | ENDIF. | 35 |
| 1-4-13 | Include the AnnouncementCode parameter in the AnnouncementList parameter set to Reorder or other appropriate announcement. | 36 |
| 1-4-14 | Set the PointOfReturn to <i>ToneTermination</i> (this is the default treatment). | 37 |
| 1-5 | (This is the Unroutable PointOfDetection.): | 38 |
| 1-5-1 | Execute the “HLR FA Unroutable MS Invocation” task (see 5.12.10). | 39 |
| 1-5-2 | IF the PointOfReturn is indicated: | 40 |

1
2
3
4
5
6
7
8
9
10
11
12
13
14
15
16
17
18
19
20
21
22
23
24
25
26
27
28
29
30
31
32
33
34
35
36
37
38
39
40
41
42
43
44
45
46
47
48
49
50
51
52
53
54
55
56
57
58
59
60

1 1-5-2-1 GOTO TraNumReqPointOfReturn.
2 1-5-3 ENDIF.
3
4 1-5-4 Execute the “HLR MAH Unroutable MS Invocation” task (see 5.14.11).
5 1-5-5 IF the PointOfReturn is indicated:
6 1-5-5-1 GOTO TraNumReqPointOfReturn.
7 1-5-6 ENDIF.
8 1-5-7 Execute the “HLR CFNA Unroutable MS Invocation” task (see 5.4.10).
9 1-5-8 IF the PointOfReturn is indicated:
10 1-5-8-1 GOTO TraNumReqPointOfReturn.
11 1-5-9 ENDIF.
12 1-5-10 Execute the “HLR CFD Unroutable MS Invocation” task (see 5.3.11).
13 1-5-11 IF the PointOfReturn is indicated:
14 1-5-11-1 GOTO TraNumReqPointOfReturn.
15 1-5-12 ENDIF.
16 1-5-13 Include the AnnouncementCode parameter in the AnnouncementList
17 parameter set to Reorder or other appropriate announcement.
18 1-5-14 Set the PointOfReturn to *ToneTermination* (this is the default treatment).
19 1-6 *Unconditional* (This is the Unconditional Failure PointOfDetection.):
20 1-6-1 Execute the “HLR CFU Unconditional MS Invocation” task (see 5.5.6).
21 1-6-2 IF the PointOfReturn is indicated:
22 1-6-2-1 GOTO TraNumReqPointOfReturn.
23 1-6-3 ENDIF.
24 1-6-4 Include the AnnouncementCode parameter in the AnnouncementList
25 parameter set to Reorder or other appropriate announcement.
26 1-6-5 Set the PointOfReturn to *ToneTermination* (this is the default treatment).
27 1-7 *DEFAULT*:
28 1-7-1 Include the AnnouncementCode parameter in the AnnouncementList
29 parameter set to Reorder or other appropriate announcement.
30 1-7-2 Set the PointOfReturn to *ToneTermination* (this is the default treatment).
31 1-8 ENDCASE.
32 **T N O**
33 1-9 Relay the AnnouncementList parameter.
34 1-10 CASE PointOfReturn OF:
35 1-11 *ToneTermination* PointOfReturn:
36 1-11-1 Send a RETURN RESULT.
37 1-11-2 Exit this task.
38 1-12 *PSTNTermination* PointOfReturn:
39 1-12-1 Execute the “HLR CNIP Redirecting Call Invocation” task (see 5.8.2).
40 1-12-2 Include other parameters for PSTN termination as determined by the feature.
41 1-12-3 Send a RETURN RESULT.
42 1-13 *LocalTermination* PointOfReturn:
43 1-13-1 GOTO TraNumReqMultTerm.
44
45
46
47
48
49
50
51
52
53
54
55
56
57
58
59
60

| | | |
|--------------|--|----|
| 1-14 | <i>IntersystemTermination</i> PointOfReturn: | 1 |
| 1-14-1 | GOTO TraNumReqMultTerm. | 2 |
| 1-15 | <i>MultipleTermination</i> PointOfReturn: | 3 |
| T N | T | 4 |
| 1-15-1 | IF at least one of the routes on the list is for an <i>IntersystemTermination</i> or a <i>PSTNTermination</i> : | 5 |
| | | 6 |
| 1-15-1-1 | FOR all desired routes in list: | 7 |
| | | 8 |
| 1-15-1-1-1 | CASE type of route desired OF: | 9 |
| 1-15-1-1-2 | <i>LocalTermination</i> : | 10 |
| 1-15-1-1-2-1 | Include parameters for <i>_local</i> termination within the <i>LocalTermination</i> parameter as determined by the feature. | 11 |
| | | 12 |
| 1-15-1-1-2-2 | Include the <i>LocalTermination</i> parameter within <i>TerminationList</i> parameter. | 13 |
| | | 14 |
| 1-15-1-1-3 | <i>IntersystemTermination</i> : | 15 |
| 1-15-1-1-3-1 | Include parameters for an intersystem termination within the <i>IntersystemTermination</i> parameter as determined by the feature. | 16 |
| | | 17 |
| 1-15-1-1-3-2 | Include the <i>IntersystemTermination</i> parameter within <i>TerminationList</i> parameter. | 18 |
| | | 19 |
| 1-15-1-1-4 | <i>PSTNTermination</i> : | 20 |
| 1-15-1-1-4-1 | Include parameters for PSTN termination within the <i>PSTNTermination</i> parameter as determined by the feature. | 21 |
| | | 22 |
| 1-15-1-1-4-2 | Include the <i>PSTNTermination</i> parameter within <i>TerminationList</i> parameter. | 23 |
| | | 24 |
| 1-15-1-1-5 | ENDCASE. | 25 |
| 1-15-1-2 | ENDFOR. | 26 |
| 1-15-1-3 | Send a RETURN RESULT. | 27 |
| 1-15-2 | ENDIF. | 28 |
| 1-16 | <i>DEFAULT</i> : | 29 |
| 1-16-1 | Send a RETURN ERROR with Error Code <i>FeatureInactive</i> . | 30 |
| 1-17 | ENDCASE. | 31 |
| 2 | ELSE: | 32 |
| 2-1 | Send a RETURN ERROR with a proper Error Code value (see the following table) to the requesting MSC. | 33 |
| | | 34 |
| 3 | ENDIF. | 35 |
| 4 | Exit this task. | 36 |
| | | 37 |
| | | 38 |
| | | 39 |
| | | 40 |
| | | 41 |
| | | 42 |
| | | 43 |
| | | 44 |
| | | 45 |
| | | 46 |
| | | 47 |
| | | 48 |
| | | 49 |
| | | 50 |
| | | 51 |
| | | 52 |
| | | 53 |
| | | 54 |
| | | 55 |
| | | 56 |
| | | 57 |
| | | 58 |
| | | 59 |
| | | 60 |

Table 60 HLR TransferToNumberRequest Response

| Problem Detection and Recommended Response from HLR to MSC-V | | | | | | | | | | |
|--|---|---|---|---|---|---|---|---|---|-------|
| PROBLEM DEFINITION | 1 | 2 | 3 | 4 | 5 | 6 | 7 | 8 | 9 | Notes |
| RETURN ERROR | | | | | | | | | | |
| Error Code | | | | | | | | | | |
| <i>UnrecognizedMIN</i> | | | | | | | X | | | |
| <i>UnrecognizedESN</i> | | | | | | | | X | | |
| <i>MIN/HLRMismatch</i> | | | | | | X | | | | |
| <i>OperationSequenceProblem</i> | | | | | | | | | | a |
| <i>ResourceShortage</i> | | X | | | | | | | | |
| <i>OperationNotSupported</i> | X | | | | | | | | | b |
| <i>TrunkUnavailable</i> | | | | | | | | | | a |
| <i>ParameterError</i> | | | | X | | | | | | d |
| <i>SystemFailure</i> | | | X | | | | | | | |
| <i>UnrecognizedParameterValue</i> | | | | | X | | | | | d |
| <i>FeatureInactive</i> | | | | | | | | | X | |
| <i>MissingParameter</i> | | | | | | | | | | a |
| RETURN RESULT | | | | | | | | | | c |

Problem Detections:

1. The requested MAP operation is recognized, but not supported, by the receiving HLR, or the requesting functional entity is not authorized.
2. A required HLR resource (e.g., internal memory record, HLR is fully occupied) is temporarily not available (e.g., congestion).
3. A required resource (e.g., data base access, functional entity) is not presently accessible due to a failure. Human intervention may be required for resolution.
4. A supplied parameter has an encoding problem (e.g., the supplied MobileIdentificationNumber parameter digit values do not meet the BCD specification).
5. A supplied parameter value is unrecognized or has nonstandard values (e.g., the RedirectionReason is set to *Not used*).
6. The supplied MobileIdentificationNumber parameter is not in the HLR's range of MINs or directory numbers (suspect routing error).
7. The supplied MobileIdentificationNumber parameter is within the range of the HLR, but the MIN is not present assigned to a subscriber or the MIN is either a *Delinquent Account*, *Stolen Unit*, *Duplicate Unit*, or *Unspecified*.
8. The supplied MobileIdentificationNumber parameter is within the range of the HLR, but the supplied ElectronicSerialNumber parameter is not valid for the MIN's record.
9. The supplied MobileIdentificationNumber parameter is within the range of the HLR, but the attempt to retrieve the appropriate Call Forwarding number resulted in failure because the identified feature was not active.

Notes:

- a. This Error Code is not an appropriate HLR response to a TransferToNumberRequest transaction.
- b. It is recommended that an HLR supports TransferToNumberRequest transactions.
- c. Only RETURN RESULT operations needing clarification have been included.
- d. Include the *Parameter Identifier* in question as the FaultyParameter parameter.

4.50 TRUNK TEST

See Chapter 4 for the Trunk Test procedures.

4.51 TRUNK TEST DISCONNECT

See Chapter 4 for the Trunk Test Disconnect procedures.

4.52 UNBLOCKING

See Chapter 4 for the Unblocking procedures.

4.53 UNRELIABLE ROAMER DATA DIRECTIVE

This section describes the procedures at the HLR and VLR when the HLR returns to a stable state after suffering a data failure.

4.53.1 HLR Initiating a Unreliable Roamer Data Directive

When an HLR returns to a stable state after suffering a data failure, it shall perform the following for each of its associated VLRs:

- 1 Include the MSCID parameter set to the identity of the HLR.
- 2 Include the SenderIdentificationNumber set to the identification number of the HLR.
- 3 Send an UnreliableRoamerDataDirective INVOKE to the VLR.
- 4 Start the Unreliable Roamer Data Directive Timer (URDDT).
- 5 WAIT for a Unreliable Roamer Data Directive response:
 - 6 WHEN a RETURN RESULT is received:
 - 6-1 Stop timer (URDDT).
 - 6-2 IF the message cannot be processed:
 - 6-2-1 Execute "Local Recovery Procedures" task (see 3.5.1).
 - 6-3 ENDIF.
 - 7 WHEN a RETURN ERROR or REJECT is received:
 - 7-1 Stop timer (URDDT).
 - 7-2 Execute "Local Recovery Procedures " task (see 3.5.1).
 - 8 WHEN timer (URDDT) expires:
 - 8-1 Execute "Local Recovery Procedures " task (see 3.5.1).
 - 9 ENDWAIT.
 - 10 (The pointers to the affected MSs should be clear by this point.)
 - 11 Exit this task.

4.53.2 VLR Receiving UnreliableRoamerDataDirective INVOKE

When a VLR receives a UnreliableRoamerDataDirective INVOKE, it shall perform the following:

- 1 IF the received message can be processed:

- 1-1 Send a RETURN RESULT to the requesting HLR.
- 1-2 Clear the records of those MSs associated with the requesting HLR.
- 2 ELSE (the received message cannot be processed):
- 2-1 Send a RETURN ERROR with a proper Error Code value to the requesting HLR.
- 3 ENDIF.
- 4 Exit this task.

Table 61 VLR UnreliableRoamerDataDirective Response

| Problem Detection and Recommended Response
from VLR to HLR | | | | | |
|---|----------|----------|----------|----------|--------------|
| PROBLEM DEFINITION | 1 | 2 | 3 | 4 | Notes |
| RETURN ERROR
Error Code | | | | | |
| <i>UnrecognizedMIN</i> | | | | | a |
| <i>UnrecognizedESN</i> | | | | | a |
| <i>MIN/HLRMismatch</i> | | | | | a |
| <i>OperationSequenceProblem</i> | | | | | a |
| <i>ResourceShortage</i> | | X | | | |
| <i>OperationNotSupported</i> | X | | | | b |
| <i>TrunkUnavailable</i> | | | | | a |
| <i>ParameterError</i> | | | | | a |
| <i>SystemFailure</i> | | | X | | |
| <i>UnrecognizedParameterValue</i> | | | | | a |
| <i>FeatureInactive</i> | | | | | a |
| <i>MissingParameter</i> | | | | | a |
| RETURN RESULT | | | | X | c |

Problem Detections:

1. Requested MAP operation is recognized, but not supported, by the receiving VLR, or the requesting functional entity is not authorized.
2. A required receiving VLR resource (internal memory record, VLR is fully occupied) is temporarily not available (e.g., congestion).
3. A required resource (e.g., data base access, functional entity) is not presently accessible due to a failure. Human intervention may be required for resolution.
4. Supplied parameter MSCID (HLR) value was recognized by the receiving VLR even if some MSCID (HLR) identified subscribers are presently involved in call traffic. (The VLR shall discard the records associated with active calls upon call termination.).

Notes:

- a. This Error Code is not an appropriate VLR response to a UnreliableRoamerDataDirective transaction.
- b. It is recommended that a VLR support UnreliableRoamerDataDirective transactions.
- c. Only RETURN RESULT operations needing clarification have been included.

4.54 UNSOLICITED RESPONSE

4.54.1 MSC Detecting an Unsolicited Page Response

When an MSC detects an unsolicited page response from an MS, it shall perform the following:

- 1 Process MS presence confirmation procedure.¹
- 2 WAIT for an MS response:
- 3 WHEN MS presence is confirmed:²
 - 3-1 IF the Border MSC needs to retrieve the MS's qualification information, optionally:
 - 3-1-1 Execute "MSC Initiating a Qualification Request" task (see 4.33.1).
 - 3-2 ENDIF.
 - 3-3 IF a TLDN is available:
 - 3-3-1 Assign a TLDN to the indicated MS.
 - 3-3-2 Assign a billing identifier to the TLDN.
 - 3-3-3 Store the Originating MSC ID information and information related to the indicated MS with the assigned TLDN.
 - 3-3-4 Include the MSCID parameter set to the identity of the MSC.
 - 3-3-5 Include the Digits (Destination) parameter set to the TLDN.
 - 3-3-6 Include the PC_SSN parameter with the Type field set to *Serving MSC* and the PC and SSN fields set to the MSC's point code and subsystem number.
 - 3-3-7 Include the BillingID (Serving) parameter set to the TLDN billing identifier.
 - 3-3-8 Include the SystemAccessType parameter set to *Page response*.
 - 3-3-9 Send an UnsolicitedPageResponse INVOKE to Border MSCs.
 - 3-3-10 Start the Unsolicited Response timer (URT).
 - 3-3-11 WAIT for an Unsolicited Response response:
 - 3-3-12 WHEN a RETURN RESULT is received:
 - 3-3-12-1 Stop timer (URT).
 - 3-3-12-2 IF the message can be processed:
 - 3-3-12-2-1 Execute "MSC Initiating an Authentication Request" task (see 4.4.1) to authenticate the MS.
 - 3-3-12-2-2 IF the MS is authentic:
 - 3-3-12-2-2-1 Execute "MSC Initiating MS Registration" task (see 4.38.1) to properly register the MS.

¹MS presence confirmation consists of paging the MS and voice channel assignment with either SAT detection or voice channel audit.

²MS presence confirmation consists of paging the MS and voice channel assignment with either SAT detection or voice channel audit.

1 3-3-12-2-2-2 Execute the “Wait for TLDN Call” task (see 3.3.2).
2
3 3-3-12-2-3 ELSE:
4 3-3-12-2-3-1 Release the TLDN for other purposes.
5 3-3-12-2-4 ENDIF.
6
7 3-3-12-3 ENDIF.
8
9 3-3-13 WHEN a RETURN ERROR or REJECT is received:
10 3-3-13-1 Release the voice or traffic channel.
11 3-3-13-2 Release the TLDN for other purposes.
12 3-3-13-3 Stop timer (URT).
13 3-3-13-4 Execute “Local Recovery Procedures” task (see 3.5.1).
14
15 3-3-14 WHEN timer (URT) expires:
16 3-3-14-1 Release the voice or traffic channel.
17 3-3-14-2 Release the TLDN for other purposes.
18 3-3-14-3 Execute “Local Recovery Procedures” task (see 3.5.1).
19
20 3-3-15 ENDWAIT.
21
22 3-4 ELSE (no TLDN is available):
23 3-4-1 Release the voice or traffic channel.
24 3-4-2 Exit this task.
25
26 3-5 ENDIF.
27
28 4 WHEN the MS fails to confirm its presence:
29 4-1 Release the voice or traffic channel.
30
31 5 ENDWAIT.
32 6 Exit this task.

4.54.2 MSC Receiving UnsolicitedResponse INVOKE

When an MSC receives an UnsolicitedResponse INVOKE, it shall perform the following:

1 IF the received message can be processed:
2 1-1 IF the SystemAccessType parameter is received:
3 1-1-1 IF the SystemAccessType is *Page response*:
4 1-1-1-1 IF the received message can be correlated with a pending page:
5 1-1-1-1-1 Include the MSCID and PC_SSN parameters set to the Originating
6 MSC’s MSCID and PC_SSN.
7 1-1-1-1-2 Send a RETURN RESULT to the requesting MSC.
8 1-1-1-1-3 Pass a Unsolicited Page Response Notification with the received
9 parameters to the waiting page in the “Page an MS Procedure” (see
10 3.3.3).
11 1-1-1-2 ELSE (the received message cannot be correlated with a pending
12 RoutingRequest INVOKE):
13 1-1-1-2-1 Send a RETURN ERROR with the proper Error Code value (see the
14 following table).
15 1-1-1-3 ENDIF.

- 1-1-2 ELSE (the SystemAccessType is not *Page response*):
 - 1-1-2-1 Send a RETURN ERROR with the proper Error Code value (see the following table).
 - 1-1-3 ENDIF.
- 1-2 ELSE (SystemAccessType parameter is not received; assume it is a *Page response*):
 - 1-2-1 IF the received message can be correlated with a pending page:
 - 1-2-1-1 Include the MSCID and PC_SSN parameters set to the Originating MSC's MSCID and PC_SSN..
 - 1-2-1-2 Send a RETURN RESULT to the requesting MSC.
 - 1-2-1-3 Pass a Unsolicited Page Response Notification with the received parameters to the waiting page in the "Page an MS Procedure" (see 3.3.3).
 - 1-2-2 ELSE (the received message cannot be correlated with a pending RoutingRequest INVOKE):
 - 1-2-2-1 Send a RETURN ERROR with the proper Error Code value (see the following table).
 - 1-2-3 ENDIF.
- 1-3 ENDIF.
- 2 ELSE (the received message cannot be processed):
 - 2-1 Send a RETURN ERROR with the proper Error Code value (see the following table).
 - 3 ENDIF.
 - 4 Exit this task.

Table 62 Neighboring MSC UnsolicitedPageResponse Response

| Problem Detection and Recommended Response from Neighboring MSC to Border MSC | | | | | | | | | |
|---|---|---|---|---|---|---|---|---|-------|
| PROBLEM DEFINITION | 1 | 2 | 3 | 4 | 5 | 6 | 7 | 8 | Notes |
| RETURN ERROR | | | | | | | | | |
| Error Code | | | | | | | | | |
| <i>UnrecognizedMIN</i> | | | | | | | | X | a |
| <i>UnrecognizedESN</i> | | | | | | | X | | |
| <i>MIN/HLRMismatch</i> | | | | | | | | | a |
| <i>OperationSequenceProblem</i> | | | | | | | | | a |
| <i>ResourceShortage</i> | | X | | | | | | | |
| <i>OperationNotSupported</i> | X | | | | | | | | b |
| <i>TrunkUnavailable</i> | | | | | | | | | a |
| <i>ParameterError</i> | | | | | X | | | | d |
| <i>SystemFailure</i> | | | X | | | | | | e |
| <i>UnrecognizedParameterValue</i> | | | | X | | | | | d |
| <i>FeatureInactive</i> | | | | | | | | | a |
| <i>MissingParameter</i> | | | | | | X | | | d |
| RETURN RESULT | | | | | | | | | c |

Problem Detections:

1. The requested MAP operation is recognized, but not supported by the receiving MSC or the requesting functional entity is not authorized.

1
2
3
4
5
6
7
8
9
10
11
12
13
14
15
16
17
18
19
20
21
22
23
24
25
26
27
28
29
30
31
32
33
34
35
36
37
38
39
40
41
42
43
44
45
46
47
48
49
50
51
52
53
54
55
56
57
58
59
60

- 1 2. A required Border MSC resource (e.g., internal memory record, MSC is fully occupied) is
2 temporarily not available (e.g., congestion).
- 3 3. A required resource (e.g., data base access, functional entity) is not presently accessible due to a
4 failure. Human intervention may be required for resolution.
- 5 4. A supplied parameter value is unrecognized or has nonstandard values (e.g., *Not used*, the supplied
6 MobileIdentificationNumber parameter digit values do not meet the expected BCD specification, the
7 supplied SystemAccessType value was not *Page response*, the supplied ExtendedMSCID parameter
8 Type field value was not *Border MSC*).
- 9 5. Two or more mutually exclusive optional parameters have been supplied.
- 10 6. An optional parameter required by the Border MSC was expected, but not received.
- 11 7. The supplied ElectronicSerialNumber parameter is not valid for the recognized MIN's record.
- 12 8. UnsolicitedPageResponse activity for the supplied MobileIdentificationNumber parameter is not
13 supported at this time, e.g.,
 - 14 • The supplied MS identified by the MobileIdentificationNumber and ElectronicSerialNumber
15 parameters is not currently registered in this Neighboring MSC;
 - 16 • An UnsolicitedPageResponse procedure is currently active for the supplied MIN; or
 - 17 • The supplied MobileIdentificationNumber parameter is registered in this Neighboring MSC, but the
18 MIN does not currently have call activity in-progress or a pending RoutingRequest.

19 Notes:

- 20 a. This Error Code is not an appropriate Neighboring MSC response to an UnsolicitedPageResponse
21 transaction.
 - 22 b. It is recommended that all MSCs support UnsolicitedPageResponse transactions.
 - 23 c. Only the RETURN RESULT operations needing clarification have been included.
 - 24 d. Include the *Parameter Identifier* in question as the FaultyParameter parameter.
- 25
26
27
28
29
30
31
32
33
34
35
36
37
38
39
40
41
42
43
44
45
46
47
48
49
50
51
52
53
54
55
56
57
58
59
60

5 VOICE FEATURE PROCEDURES

This section describes modular procedures to implement individual features.

5.1 CALL DELIVERY (CD)

5.1.1 HLR CD Activation

Upon request, the HLR shall do the following:

- 1 IF CD is authorized:
 - 1-1 Activate CD.
 - 1-2 Optionally, include the `AnnouncementCode` parameter in the `AnnouncementList` parameter set to an appropriate announcement.
 - 1-3 Include the `FeatureResult` parameter set to *Successful* to indicate successful feature operation.
- 2 ELSE:
 - 2-1 Optionally, include the `AnnouncementCode` parameter in the `AnnouncementList` parameter set to an appropriate announcement.
 - 2-2 Include the `FeatureResult` parameter set to *Unsuccessful* to indicate unsuccessful feature operation.
- 3 ENDIF.
- 4 Set `PointOfReturn` to *ToneTermination*.
- 5 Return to calling task via the `PointOfReturn`.

5.1.2 HLR CD De-Activation

Upon request, the HLR shall do the following:

- 1 IF CD is authorized:
 - 1-1 De-activate CD.
 - 1-2 Optionally, include the `AnnouncementCode` parameter in the `AnnouncementList` parameter set to an appropriate announcement.
 - 1-3 Include the `FeatureResult` parameter set to *Successful* to indicate successful feature operation.
- 2 ELSE:
 - 2-1 Optionally, include the `AnnouncementCode` parameter in the `AnnouncementList` parameter set to an appropriate announcement.
 - 2-2 Include the `FeatureResult` parameter set to *Unsuccessful* to indicate unsuccessful feature operation.
- 3 ENDIF.
- 4 Set `PointOfReturn` to *ToneTermination*.
- 5 Return to calling task via the `PointOfReturn`.

5.1.3 HLR CD Incoming Call Invocation

When the HLR determines the need for CD incoming call routing, it shall perform the following tasks:

- 1 IF the addressed MS is at home or CD is active and the MS is roaming:
 - 1-1 IF the addressed MS is registered and active:
 - 1-1-1 (Load the parameters for the called MS and common parameters outside the TerminationList parameter.)
 - 1-1-2 Include the ElectronicSerialNumber to identify the called MS.
 - 1-1-3 Include the MobileIdentificationNumber to identify the called MS.
 - 1-1-4 IF the preferred interexchange carrier is applicable for the call:
 - 1-1-4-1 Include the Digits (Carrier) parameter.
 - 1-1-5 ENDIF.
 - 1-1-6 IF an account code is applicable for the call:
 - 1-1-6-1 Include the DMH_AccountCodeDigits parameter.
 - 1-1-7 ENDIF.
 - 1-1-8 IF an alternate billing number is applicable for the call:
 - 1-1-8-1 Include the DMH_AlternateBillingDigits parameter.
 - 1-1-9 ENDIF.
 - 1-1-10 IF a billing number is applicable for the call:
 - 1-1-10-1 Include the DMH_BillingDigits parameter.
 - 1-1-11 ENDIF.
 - 1-1-12 IF a called mobile directory number is applicable for the call:
 - 1-1-12-1 Include the MobileDirectoryNumber parameter.
 - 1-1-13 ENDIF.
 - 1-1-14 IF custom no answer timing is applicable for the call:
 - 1-1-14-1 Include the NoAnswerTime parameter.
 - 1-1-15 ENDIF.
 - 1-1-16 IF special features are applicable to the called party for the incoming call:
 - 1-1-16-1 Include the OneTimeFeatureIndicator parameter.
 - 1-1-17 ENDIF.
 - 1-1-18 IF special routing is applicable for the incoming call:
 - 1-1-18-1 Include the RoutingDigits parameter.
 - 1-1-19 ENDIF.
 - 1-1-20 IF triggers should be set for the terminating party at the originating switch for the incoming call:
 - 1-1-20-1 Include the TerminationTriggers parameter.
 - 1-1-21 ENDIF.
 - 1-1-22 IF the MS is served by the requesting system:
 - 1-1-22-1 Include the DMH_RedirectionIndicator parameter set to *CD local*.
 - 1-1-22-2 Execute the “HLR CNIP Terminating Call Invocation” task (see 5.8.1).

| | | |
|--------------|---|----|
| 1-1-22-3 | Optionally, include the <code>AnnouncementCode</code> parameter in the <code>AnnouncementList</code> parameter set to an appropriate announcement. | 1 |
| | | 2 |
| | | 3 |
| 1-1-22-4 | IF the requesting MSC is capable of at least one <code>MultipleTerminations</code> according to the <code>TransactionCapability</code> received with the <code>LocationRequest</code> INVOKE: | 4 |
| | | 5 |
| | | 6 |
| 1-1-22-4-1 | Include the <code>ElectronicSerialNumber</code> parameter set to identify the called MS within a <code>LocalTermination</code> parameter within a <code>TerminationList</code> parameter. | 7 |
| | | 8 |
| | | 9 |
| | | 10 |
| 1-1-22-4-2 | Include the <code>MobileIdentificationNumber</code> parameter set to identify the called MS within a <code>LocalTermination</code> parameter within a <code>TerminationList</code> parameter. | 11 |
| | | 12 |
| | | 13 |
| 1-1-22-4-3 | Include the <code>TerminationTreatment</code> parameter set to <i>MS Termination</i> within a <code>LocalTermination</code> parameter within a <code>TerminationList</code> parameter. | 14 |
| | | 15 |
| | | 16 |
| 1-1-22-4-4 | IF custom alerting is applicable for the call: | 17 |
| | | 18 |
| 1-1-22-4-4-1 | Include the <code>AlertCode</code> parameter set appropriately. | 19 |
| | | 20 |
| 1-1-22-4-5 | ENDIF. | 21 |
| 1-1-22-4-6 | IF triggers should be set for the terminating party at the originating switch for the redirecting call: | 22 |
| | | 23 |
| 1-1-22-4-6-1 | Include the <code>TerminationTriggers</code> parameter. | 24 |
| | | 25 |
| 1-1-22-4-7 | ENDIF. | 26 |
| 1-1-22-4-8 | Set the <code>PointOfReturn</code> to <i>MultipleTerminations</i> . | 27 |
| | | 28 |
| 1-1-22-5 | ELSE (multiple terminations are not allowed): | 29 |
| 1-1-22-5-1 | (Applicable parameter should be already be included.) | 30 |
| 1-1-22-5-2 | Set the <code>PointOfReturn</code> to <i>LocalTermination</i> . | 31 |
| | | 32 |
| 1-1-22-6 | ENDIF. | 33 |
| | | 34 |
| 1-1-23 | ELSE (<code>IntersystemTermination</code> applies): | 35 |
| 1-1-23-1 | Include the <code>TerminationTreatment</code> parameter set to <i>MSTermination</i> . | 36 |
| 1-1-23-2 | Include the <code>OneTimeFeatureIndicator</code> parameter set appropriately. | 37 |
| 1-1-23-3 | IF custom alerting is applicable for the call: | 38 |
| | | 39 |
| 1-1-23-3-1 | Include the <code>AlertCode</code> parameter set appropriately. | 40 |
| 1-1-23-4 | ENDIF. | 41 |
| | | 42 |
| 1-1-23-5 | IF triggers should be set for the terminating party at the terminating switch for this call: | 43 |
| | | 44 |
| 1-1-23-5-1 | Include the <code>TerminationTriggers</code> parameter. | 45 |
| | | 46 |
| 1-1-23-6 | ENDIF. | 47 |
| 1-1-23-1 | Execute the “HLR Initiating a Routing Request” task (see 4.41.1). | 48 |
| 1-1-23-2 | IF the <code>AccessDeniedReason</code> parameter is received and it can be acted upon: | 49 |
| | | 50 |
| 1-1-23-2-1 | Set the denied reason to the received <code>AccessDeniedReason</code> value: | 51 |
| | | 52 |
| 1-1-23-3 | ENDIF. | 53 |
| | | 54 |
| 1-1-23-4 | IF the <code>ConditionallyDeniedReason</code> parameter is received and it can be acted upon: | 55 |
| | | 56 |
| 1-1-23-4-1 | IF the <code>ConditionallyDeniedReason</code> is <i>Waitable</i> . | 57 |
| | | 58 |
| | | 59 |
| | | 60 |

1 1-1-23-4-1-1 IF Call Waiting is possible based upon the received
2 OneTimeFeatureIndicator.
3
4 1-1-23-4-1-1-1 Set the denied reason to *Allowed*.
5 1-1-23-4-1-2 ELSE:
6 1-1-23-4-1-2-1 Set the denied reason to *Busy*.
7 1-1-23-4-1-3 ENDIF.
8 1-1-23-4-2 ENDIF.
9 1-1-23-5 ENDIF.
10 1-1-23-6 IF denied reason value is not *Allowed* and the AccessDeniedReason
11 parameter can be acted upon:
12 1-1-23-6-1 CASE denied reason OF:
13 1-1-23-6-2 *Busy*:
14 1-1-23-6-2-1 (This is the Busy PointOfDetection.)
15 1-1-23-6-2-2 Execute the “HLR CFB Busy MS Invocation” task (see 5.2.5).
16 1-1-23-6-2-3 IF the PointOfReturn is indicated:
17 1-1-23-6-2-3-1 GOTO CDPointOfReturn.
18 1-1-23-6-2-4 ENDIF.
19 1-1-23-6-2-5 Execute the “HLR CFD Busy MS Invocation” task (see 5.3.9).
20 1-1-23-6-2-6 IF the PointOfReturn is indicated:
21 1-1-23-6-2-6-1 GOTO CDPointOfReturn.
22 1-1-23-6-2-7 ENDIF.
23 1-1-23-6-2-8 Optionally, include the AnnouncementCode parameter in the
24 AnnouncementList parameter set to an appropriate
25 announcement.
26 1-1-23-6-2-9 Relay the received AccessDeniedReason parameter.
27 1-1-23-6-2-10 Set PointOfReturn to *ToneTermination*.
28 1-1-23-6-3 *Unavailable*:
29 1-1-23-6-3-1 (This is the Unavailable PointOfDetection.)
30 1-1-23-6-3-2 Execute the “HLR CFNA Unavailable MS Invocation” task (see
31 5.4.7).
32 1-1-23-6-3-3 IF the PointOfReturn is indicated:
33 1-1-23-6-3-3-1 GOTO CDPointOfReturn.
34 1-1-23-6-3-4 ENDIF.
35 1-1-23-6-3-5 Execute the “HLR CFD Unavailable MS Invocation” task (see
36 5.3.7).
37 1-1-23-6-3-6 IF the PointOfReturn is indicated:
38 1-1-23-6-3-6-1 GOTO CDPointOfReturn.
39 1-1-23-6-3-7 ENDIF.
40 1-1-23-6-3-8 Optionally, include the AnnouncementCode parameter in the
41 AnnouncementList parameter set to an appropriate
42 announcement.
43 1-1-23-6-3-9 Relay the received AccessDeniedReason parameter.
44 1-1-23-6-3-10 Set PointOfReturn to *ToneTermination*.
45
46
47
48
49
50
51
52
53
54
55
56
57
58
59
60

| | | |
|----------------|--|----|
| 1-1-23-6-4 | <i>No Page Response:</i> | 1 |
| 1-1-23-6-4-1 | (This is the Unresponsive PointOfDetection.) | 2 |
| 1-1-23-6-4-2 | Execute the “HLR CFNA Unresponsive MS Invocation” task (see 5.4.8). | 3 |
| 1-1-23-6-4-3 | IF the PointOfReturn is indicated: | 4 |
| 1-1-23-6-4-3-1 | GOTO CDPointOfReturn. | 5 |
| 1-1-23-6-4-4 | ENDIF. | 6 |
| 1-1-23-6-4-5 | Execute the “HLR CFD Unresponsive MS Invocation” task (see 5.3.8). | 7 |
| 1-1-23-6-4-6 | IF the PointOfReturn is indicated: | 8 |
| 1-1-23-6-4-6-1 | GOTO CDPointOfReturn. | 9 |
| 1-1-23-6-4-7 | ENDIF. | 10 |
| 1-1-23-6-4-8 | Optionally, include the AnnouncementCode parameter in the AnnouncementList parameter set to an appropriate announcement. | 11 |
| 1-1-23-6-4-9 | Relay the received AccessDeniedReason parameter. | 12 |
| 1-1-23-6-4-10 | Set PointOfReturn to <i>ToneTermination</i> . | 13 |
| 1-1-23-6-5 | <i>Inactive:</i> | 14 |
| 1-1-23-6-5-1 | (This is the Inactive PointOfDetection, which is the same as the DEFAULT treatment.) | 15 |
| 1-1-23-6-6 | <i>Unassigned directory number:</i> | 16 |
| 1-1-23-6-6-1 | (This value is not expected, give DEFAULT treatment) | 17 |
| 1-1-23-6-7 | <i>Termination Denied:</i> | 18 |
| 1-1-23-6-7-1 | (This value is not expected, give DEFAULT treatment) | 19 |
| 1-1-23-6-8 | <i>DEFAULT:</i> | 20 |
| 1-1-23-6-8-1 | (This is the DEFAULT PointOfDetection.) | 21 |
| 1-1-23-6-8-2 | Set the MS state to <i>inactive</i> . | 22 |
| 1-1-23-6-8-3 | Execute the “HLR CFNA Inactive MS Invocation” task (see 5.4.6). | 23 |
| 1-1-23-6-8-4 | IF the PointOfReturn is indicated: | 24 |
| 1-1-23-6-8-4-1 | GOTO CDPointOfReturn. | 25 |
| 1-1-23-6-8-5 | ENDIF. | 26 |
| 1-1-23-6-8-6 | Execute the “HLR CFD Inactive MS Invocation” task (see 5.3.6). | 27 |
| 1-1-23-6-8-7 | IF the PointOfReturn is indicated: | 28 |
| 1-1-23-6-8-7-1 | GOTO CDPointOfReturn. | 29 |
| 1-1-23-6-8-8 | ENDIF. | 30 |
| 1-1-23-6-8-9 | Optionally, include the AnnouncementCode parameter in the AnnouncementList parameter set to an appropriate announcement. | 31 |
| 1-1-23-6-8-10 | Relay the received AccessDeniedReason parameter. | 32 |
| 1-1-23-6-8-11 | Set PointOfReturn to <i>ToneTermination</i> . | 33 |
| 1-1-23-6-9 | ENDCASE. | 34 |
| | | 35 |
| | | 36 |
| | | 37 |
| | | 38 |
| | | 39 |
| | | 40 |
| | | 41 |
| | | 42 |
| | | 43 |
| | | 44 |
| | | 45 |
| | | 46 |
| | | 47 |
| | | 48 |
| | | 49 |
| | | 50 |
| | | 51 |
| | | 52 |
| | | 53 |
| | | 54 |
| | | 55 |
| | | 56 |
| | | 57 |
| | | 58 |
| | | 59 |
| | | 60 |

1 1-1-23-6-10 GOTO CDPointOfReturn.
2
3 1-1-23-7 ENDIF.
4 1-1-23-8 IF the Digits (Destination) parameter is received:
5 1-1-23-8-1 Include the DMH_RedirectionIndicator parameter set to *CD*
6 *unspecified*, *CD PSTN*, or *CD Private*, as appropriate.
7
8 1-1-23-8-2 Execute the “HLR CNIP Redirecting Call Invocation” task (see
9 5.8.2).
10 1-1-23-8-3 Optionally, include the AnnouncementCode parameter in the
11 AnnouncementList parameter set to an appropriate announcement.
12 1-1-23-8-4 Set PointOfReturn to *IntersystemTermination*.
13 1-1-23-8-5 IF the requesting MSC is capable of at least one
14 MultipleTerminations according to the TransactionCapability
15 received with the LocationRequest INVOKE:
16
17 1-1-23-8-5-1 Include the DestinationDigits parameter set to the received
18 Digits (Destination) within an IntersystemTermination parameter
19 within a TerminationList parameter.
20 1-1-23-8-5-2 Relay the received MSCID parameter of the Serving MSC
21 within an IntersystemTermination parameter within a
22 TerminationList parameter.
23 1-1-23-8-5-3 IF the BillingID parameter was received:
24 1-1-23-8-5-3-1 Relay the BillingID parameter of the Serving (Anchor) MSC
25 within an IntersystemTermination parameter within a
26 TerminationList parameter.
27 1-1-23-8-5-4 ENDIF.
28 1-1-23-8-5-5 IF the MSCIdentificationNumber parameter was received:
29 1-1-23-8-5-5-1 Relay the MSCIdentificationNumber parameter of the
30 Serving MSC within an IntersystemTermination parameter
31 within a TerminationList parameter.
32 1-1-23-8-5-6 ENDIF.
33 1-1-23-8-5-7 IF the PC_SSN (Serving) parameter was received:
34 1-1-23-8-5-7-1 Relay the PC_SSN (Serving) parameter within the
35 IntersystemTermination parameter within the
36 TerminationList parameter.
37 1-1-23-8-5-8 ENDIF.
38 1-1-23-8-6 ELSE (multiple terminations are not allowed).
39 1-1-23-8-6-1 Relay the Digits (Destination) parameter.
40 1-1-23-8-6-2 IF the PC_SSN (Serving) parameter was received:
41 1-1-23-8-6-2-1 Relay the PC_SSN (Serving) parameter.
42 1-1-23-8-6-3 ENDIF.
43 1-1-23-8-7 ENDIF.
44 1-1-23-9 ELSE (Digits (Destination) parameter is not received, so there is no way
45 to route call):
46 1-1-23-9-1 Optionally, include the AnnouncementCode parameter in the
47 AnnouncementList parameter set to the inaccessible subscriber
48 announcement.
49
50
51
52
53
54
55
56
57
58
59
60

| | | |
|------------|---|----|
| 1-1-23-9-2 | Set PointOfReturn to <i>ToneTermination</i> . | 1 |
| 1-1-23-9-3 | GOTO CDPointOfReturn. | 2 |
| 1-1-23-10 | ENDIF. | 3 |
| 1-1-24 | ENDIF. | 4 |
| 1-2 | ELSE (MS is either not registered or is not active): | 5 |
| 1-2-1 | Execute the “HLR CFNA Inactive MS Invocation” task (see 5.4.6). | 6 |
| 1-2-2 | IF the PointOfReturn is indicated: | 7 |
| 1-2-2-1 | GOTO CDPointOfReturn. | 8 |
| 1-2-3 | ENDIF. | 9 |
| 1-2-4 | Execute the “HLR CFD Inactive MS Invocation” task (see 5.3.6). | 10 |
| 1-2-5 | IF the PointOfReturn is indicated: | 11 |
| 1-2-5-1 | GOTO CDPointOfReturn. | 12 |
| 1-2-6 | ENDIF. | 13 |
| 1-2-7 | Optionally, include the AnnouncementCode parameter in the AnnouncementList parameter set to the inaccessible subscriber announcement. | 14 |
| 1-2-8 | Set PointOfReturn to <i>ToneTermination</i> . | 15 |
| 1-3 | ENDIF. | 16 |
| | O | 17 |
| 1-5 | CASE PointOfReturn OF: | 18 |
| 1-6 | <i>ToneTermination</i> : | 19 |
| 1-6-1 | Include the MSCID parameter set to the identity of the Originating MSC. | 20 |
| 1-7 | <i>LocalTermination</i> : | 21 |
| 1-7-1 | Include the MSCID parameter set to the identity of the Originating MSC. | 22 |
| 1-7-2 | Execute the “HLR CNIP Terminating Call Invocation” task (see 5.8.1). | 23 |
| 1-8 | <i>IntersystemTermination</i> : | 24 |
| 1-8-1 | Include the MSCID parameter set to the identity of the Serving MSC. | 25 |
| 1-8-2 | Execute the “HLR CNIP Redirecting Call Invocation” task (see 5.8.2). | 26 |
| 1-9 | <i>PSTNTermination</i> : | 27 |
| 1-9-1 | Include the MSCID parameter set to the identity of the Originating MSC. | 28 |
| 1-9-2 | IF preferred interexchange carrier is applicable: | 29 |
| 1-9-2-1 | Include the Digits (Carrier) parameter set to the MS’s preferred interexchange carrier. | 30 |
| 1-9-3 | ENDIF. | 31 |
| 1-9-4 | Execute the “HLR CNIP Redirecting Call Invocation” task (see 5.8.2). | 32 |
| 1-10 | <i>MultipleTermination</i> : | 33 |
| 1-10-1 | Include the MSCID parameter set to the identity of the Originating MSC. | 34 |
| 1-10-2 | IF at least one of the routes on the list is for a <i>LocalTermination</i> : | 35 |
| 1-10-2-1 | Execute the “HLR CNIP Terminating Call Invocation” task (see 5.8.1). | 36 |
| 1-10-3 | ENDIF. | 37 |
| 1-10-4 | IF at least one of the routes on the list is for a <i>IntersystemTermination</i> or a <i>PSTNTermination</i> : | 38 |
| 1-10-4-1 | Execute the “HLR CNIP Redirecting Call Invocation” task (see 5.8.2). | 39 |
| | | 40 |
| | | 41 |
| | | 42 |
| | | 43 |
| | | 44 |
| | | 45 |
| | | 46 |
| | | 47 |
| | | 48 |
| | | 49 |
| | | 50 |
| | | 51 |
| | | 52 |
| | | 53 |
| | | 54 |
| | | 55 |
| | | 56 |
| | | 57 |
| | | 58 |
| | | 59 |
| | | 60 |

- 1-10-5 ENDIF.
- 1-11 *DEFAULT:*
- 1-11-1 Send a RETURN ERROR with Error Code *SystemFailure*.
- 1-11-2 Return to calling task via the PointOfReturn.
- 1-12 ENDCASE.
- 2 ELSE:
- 2-1 (Allow the call to continue.)
- 3 ENDIF.
- 4 Return to the calling process via the PointOfReturn.

5.2 CALL FORWARDING BUSY (CFB)

5.2.1 HLR CFB Registration

Upon request, the HLR shall do the following:

- 1 IF CFB is authorized:
- 1-1 IF the termination address is acceptable:
- 1-1-1 Execute the “HLR SPINI Feature Request Invocation” task (see 5.21.4).
- 1-1-2 IF the SPINI invocation *failed*:
- 1-1-2-1 Include the FeatureResult parameter set to *Unsuccessful* to indicate unsuccessful feature operation.
- 1-1-2-2 Return to the calling task via the PointOfReturn.
- 1-1-3 ENDIF.
- 1-1-4 Register the termination address as the CFB forward-to number.
- 1-1-5 Optionally, include the AnnouncementCode parameter in the AnnouncementList parameter set to an appropriate announcement.
- 1-1-6 Include the FeatureResult parameter set to *Successful* to indicate successful feature operation.
- 1-1-7 IF activation is to occur with registration.
- 1-1-7-1 Optionally, include the AnnouncementCode parameter in the AnnouncementList parameter set to an appropriate announcement.
- 1-1-7-2 Activate CFB.
- 1-1-7-3 IF a courtesy call is to be performed:
- 1-1-7-3-1 Optionally, include the AnnouncementCode parameter in the AnnouncementList parameter set to an appropriate announcement.
- 1-1-7-3-2 Set the selected forward-to number to the CFB forward-to number.
- 1-1-7-3-3 Execute the “HLR Select Forward-To or Diversion Number Courtesy Call Point of Return” task (see 6.1.1).
- 1-1-7-3-4 Include the DMH_RedirectionIndicator parameter set to *CFB* .
- 1-1-7-4 ELSE:
- 1-1-7-4-1 Set PointOfReturn to *ToneTermination*.
- 1-1-7-5 ENDIF.

- 1-1-8 ENDIF. 1
- 1-2 ELSE: 2
- 1-2-1 Optionally, include the `AnnouncementCode` parameter in the `AnnouncementList` parameter set to an appropriate announcement. 3
- 1-2-2 Include the `FeatureResult` parameter set to *Unsuccessful* to indicate unsuccessful feature operation. 4
- 1-2-3 Set `PointOfReturn` to *ToneTermination*. 5
- 1-3 ENDIF. 6
- 2 ELSE: 7
- 2-1 Optionally, include the `AnnouncementCode` parameter in the `AnnouncementList` parameter set to an appropriate announcement. 8
- 2-2 Include the `FeatureResult` parameter set to *Unsuccessful* to indicate unsuccessful feature operation. 9
- 2-3 Set `PointOfReturn` to *ToneTermination*. 10
- 3 ENDIF. 11
- 4 Return to calling task via the `PointOfReturn`. 12

5.2.2 HLR CFB De-Registration

Upon request, the HLR shall do the following: 13

- 1 IF CFB is authorized: 14
- 1-1 De-register the CFB forward-to number. 15
- 1-2 De-activate CFB. 16
- 1-3 Optionally, include the `AnnouncementCode` parameter in the `AnnouncementList` parameter set to an appropriate announcement. 17
- 1-4 Include the `FeatureResult` parameter set to *Successful* to indicate successful feature operation. 18
- 2 ELSE: 19
- 2-1 Optionally, include the `AnnouncementCode` parameter in the `AnnouncementList` parameter set to an appropriate announcement. 20
- 2-2 Include the `FeatureResult` parameter set to *Unsuccessful* to indicate unsuccessful feature operation. 21
- 3 ENDIF. 22
- 4 Set `PointOfReturn` to *ToneTermination*. 23
- 5 Return to calling task via the `PointOfReturn`. 24

5.2.3 HLR CFB Activation

Upon request, the HLR shall do the following: 25

- 1 IF CFB is authorized: 26
- 1-1 IF the forward-to number is registered: 27
- 1-1-1 Optionally, include the `AnnouncementCode` parameter in the `AnnouncementList` parameter set to an appropriate announcement. 28

- 1 1-1-2 Include the FeatureResult parameter set to *Successful* to indicate successful
2 feature operation.
3
4 1-1-3 Activate CFB.
5 1-1-4 IF a courtesy call is to be performed:
6 1-1-4-1 Set the selected forward-to number to the CFB forward-to number.
7 1-1-4-2 Execute the “HLR Select Forward-To or Diversion Number Courtesy Call
8 Point of Return” task (see 6.1.1).
9 1-1-4-3 Include the DMH_RedirectionIndicator parameter set to *CFB* .
10 1-1-5 ELSE:
11 1-1-5-1 Set PointOfReturn to *ToneTermination*.
12 1-1-6 ENDIF.
13 1-2 ELSE:
14 1-2-1 Optionally, include the AnnouncementCode parameter in the
15 AnnouncementList parameter set to an appropriate announcement.
16 1-2-2 Include the FeatureResult parameter set to *Unsuccessful* to indicate
17 unsuccessful feature operation.
18 1-2-3 Set PointOfReturn to *ToneTermination*.
19 1-3 ENDIF.
20 2 ELSE:
21 2-1 Optionally, include the AnnouncementCode parameter in the AnnouncementList
22 parameter set to an appropriate announcement.
23 2-2 Include the FeatureResult parameter set to *Unsuccessful* to indicate unsuccessful
24 feature operation.
25 2-3 Set PointOfReturn to *ToneTermination*.
26 3 ENDIF.
27 4 Return to calling task via the PointOfReturn.
28
29
30
31
32
33
34
35
36

37 5.2.4 HLR CFB De-Activation

38 Upon request, the HLR shall do the following:

- 39 1 IF CFB is authorized:
40 1-1 De-activate CFB.
41 1-2 Optionally, include the AnnouncementCode parameter in the AnnouncementList
42 parameter set to an appropriate announcement.
43 1-3 Include the FeatureResult parameter set to *Successful* to indicate successful feature
44 operation.
45 2 ELSE:
46 2-1 Optionally, include the AnnouncementCode parameter in the AnnouncementList
47 parameter set to an appropriate announcement.
48 2-2 Include the FeatureResult parameter set to *Unsuccessful* to indicate unsuccessful
49 feature operation.
50 3 ENDIF.
51 4 Set PointOfReturn to *ToneTermination*.
52 5 Return to calling task via the PointOfReturn.
53
54
55
56
57
58
59
60

5.2.5 HLR CFB Busy MS Invocation

When the HLR detects a busy MS, it shall perform the following tasks:

- 1 IF CFB is active and registered:
 - 1-1 Set the selected forward-to number to the CFB forward-to number.
 - 1-2 Execute the “HLR Select Forward-To or Diversion Number Point of Return” task (see 6.1.2).
 - 1-3 Include the DMH_RedirectionIndicator parameter set to *CFB*.
- 2 ELSE:
 - 2-1 Continue processing the call.
- 3 ENDIF.
- 4 Return to calling task via the PointOfReturn.

5.3 CALL FORWARDING DEFAULT (CFD)

5.3.1 HLR CFD Registration

Upon request, the HLR shall do the following:

- 1 IF CFD is authorized:
 - 1-1 IF the termination address is acceptable:
 - 1-1-1 Execute the “HLR SPINI Feature Request Invocation” task (see 5.21.4).
 - 1-1-2 IF the SPINI invocation *failed*:
 - 1-1-2-1 Include the FeatureResult parameter set to *Unsuccessful* to indicate unsuccessful feature operation.
 - 1-1-2-2 Return to the calling task via the PointOfReturn.
 - 1-1-3 ENDIF.
 - 1-1-4 Register the termination address as the CFD forward-to number.
 - 1-1-5 Optionally, include the AnnouncementCode parameter in the AnnouncementList parameter set to an appropriate announcement.
 - 1-1-6 Include the FeatureResult parameter set to *Successful* to indicate successful feature operation.
 - 1-1-7 IF activation is to occur with registration:
 - 1-1-7-1 Optionally, include the AnnouncementCode parameter in the AnnouncementList parameter set to an appropriate announcement.
 - 1-1-7-2 Activate CFD.
 - 1-1-7-3 IF a courtesy call is to be performed:
 - 1-1-7-3-1 Optionally, include the AnnouncementCode parameter in the AnnouncementList parameter set to an appropriate announcement.
 - 1-1-7-3-2 Set the selected forward-to number to the CFD forward-to number.
 - 1-1-7-3-3 Execute the “HLR Select Forward-To or Diversion Number Courtesy Call Point of Return” task (see 6.1.1).
 - 1-1-7-3-4 Include the DMH_RedirectionIndicator parameter set to *CFD*.

- 1-1-7-4 ELSE:
- 1-1-7-4-1 Set PointOfReturn to *ToneTermination*.
- 1-1-7-5 ENDIF.
- 1-1-8 ENDIF.
- 1-2 ELSE:
- 1-2-1 Optionally, include the AnnouncementCode parameter in the AnnouncementList parameter set to an appropriate announcement.
- 1-2-2 Include the FeatureResult parameter set to *Unsuccessful* to indicate unsuccessful feature operation.
- 1-2-3 Set PointOfReturn to *ToneTermination*.
- 1-3 ENDIF.
- 2 ELSE:
- 2-1 Optionally, include the AnnouncementCode parameter in the AnnouncementList parameter set to an appropriate announcement.
- 2-2 Include the FeatureResult parameter set to *Unsuccessful* to indicate unsuccessful feature operation.
- 2-3 Set PointOfReturn to *ToneTermination*.
- 3 ENDIF.
- 4 Return to calling task via the PointOfReturn.

5.3.2 HLR CFD De-Registration

Upon request, the HLR shall do the following:

- 1 IF CFD is authorized:
- 1-1 De-register the CFD forward-to number.
- 1-2 De-activate CFD.
- 1-3 Optionally, include the AnnouncementCode parameter in the AnnouncementList parameter set to an appropriate announcement.
- 1-4 Include the FeatureResult parameter set to *Successful* to indicate successful feature operation.
- 2 ELSE:
- 2-1 Optionally, include the AnnouncementCode parameter in the AnnouncementList parameter set to an appropriate announcement.
- 2-2 Include the FeatureResult parameter set to *Unsuccessful* to indicate unsuccessful feature operation.
- 3 ENDIF.
- 4 Set PointOfReturn to *ToneTermination*.
- 5 Return to calling task via the PointOfReturn.

5.3.3 HLR CFD Activation

Upon request, the HLR shall do the following:

- 1 IF CFD is authorized:

- 1-1 IF the forward-to number is registered: 1
- 2
- 1-1-1 Optionally, include the AnnouncementCode parameter in the 3
AnnouncementList parameter set to an appropriate announcement. 4
- 1-1-2 Include the FeatureResult parameter set to *Successful* to indicate successful 5
feature operation. 6
- 1-1-3 Activate CFD. 7
- 1-1-4 IF a courtesy call is to be performed: 8
- 1-1-4-1 Set the selected forward-to number to the CFD forward-to number. 9
- 1-1-4-2 Execute the “HLR Select Forward-To or Diversion Number Courtesy Call 10
Point of Return” task (see 6.1.1). 11
- 1-1-4-3 Include the DMH_RedirectionIndicator parameter set to *CFD* . 12
- 1-1-5 ELSE: 13
- 1-1-5-1 Set PointOfReturn to *ToneTermination*. 14
- 1-1-6 ENDIF. 15
- 1-2 ELSE: 16
- 1-2-1 Optionally, include the AnnouncementCode parameter in the 17
AnnouncementList parameter set to an appropriate announcement. 18
- 1-2-2 Include the FeatureResult parameter set to *Unsuccessful* to indicate 19
unsuccessful feature operation. 20
- 1-2-3 Set PointOfReturn to *ToneTermination*. 21
- 1-3 ENDIF. 22
- 2 ELSE: 23
- 2-1 Optionally, include the AnnouncementCode parameter in the AnnouncementList 24
parameter set to an appropriate announcement. 25
- 2-2 Include the FeatureResult parameter set to *Unsuccessful* to indicate unsuccessful 26
feature operation. 27
- 2-3 Set PointOfReturn to *ToneTermination*. 28
- 3 ENDIF. 29
- 4 Return to calling task via the PointOfReturn. 30
- 31
- 32
- 33
- 34
- 35
- 36
- 37
- 38
- 39
- 40

5.3.4 HLR CFD De-Activation

Upon request, the HLR shall do the following:

- 1 IF CFD is authorized: 43
- 44
- 1-1 De-activate CFD. 45
- 1-2 Optionally, include the AnnouncementCode parameter in the AnnouncementList 46
parameter set to an appropriate announcement. 47
- 1-3 Include the FeatureResult parameter set to *Successful* to indicate successful feature 48
operation. 49
- 2 ELSE: 50
- 2-1 Optionally, include the AnnouncementCode parameter in the AnnouncementList 51
parameter set to an appropriate announcement. 52
- 2-2 Include the FeatureResult parameter set to *Unsuccessful* to indicate unsuccessful 53
feature operation. 54
- 55
- 56
- 57
- 58
- 59
- 60

- 3 ENDIF.
- 4 Set PointOfReturn to *ToneTermination*.
- 5 Return to calling task via the PointOfReturn.

5.3.5 HLR CFD Incoming Call Invocation

When the HLR determines the needs for CFD incoming call routing, it shall perform the following tasks:

- 1 IF CFD is active and registered:
 - 1-1 IF the addressed MS is registered and active:
 - 1-1-1 IF DND is active OR IF CD is not active:
 - 1-1-1-1 Set the selected forward-to number to the CFD forward-to number.
 - 1-1-1-2 Execute the “HLR Select Forward-To or Diversion Number Point of Return” task (see 6.1.2).
 - 1-1-1-3 Include the DMH_RedirectionIndicator parameter set to *CFD* .
 - 1-1-2 ELSE:
 - 1-1-2-1 Continue processing the call toward the addressed MS.
 - 1-1-3 ENDIF.
 - 1-2 ELSE:
 - 1-2-1 Set the selected forward-to number to the CFD forward-to number.
 - 1-2-2 Execute the “HLR Select Forward-To or Diversion Number Point of Return” task (see 6.1.2).
 - 1-2-3 Include the DMH_RedirectionIndicator parameter set to *CFD* .
 - 1-3 ENDIF.
- 2 ELSE:
 - 2-1 Continue processing the call toward the addressed MS.
- 3 ENDIF.
- 4 Return to calling task via the PointOfReturn.

5.3.6 HLR CFD Inactive MS Invocation

When the HLR detects an inactive MS, it shall perform the following tasks:

- 1 IF CFD is active and registered:
 - 1-1 Set the selected forward-to number to the CFD forward-to number.
 - 1-2 Execute the “HLR Select Forward-To or Diversion Number Point of Return” task (see 6.1.2).
 - 1-3 Include the DMH_RedirectionIndicator parameter set to *CFD* .
- 2 ELSE:
 - 2-1 Continue processing the call.
- 3 ENDIF.
- 4 Return to calling task via the PointOfReturn.

5.3.7 HLR CFD Unavailable MS Invocation

When the HLR detects an unavailable MS, it shall perform the following tasks:

- 1 Execute the “HLR CFD Inactive MS Invocation” task (see 5.3.6).
- 2 Return to calling task via the PointOfReturn.

5.3.8 HLR CFD Unresponsive MS Invocation

When the HLR detects unresponsive subscriber, it shall perform the following tasks:

- 1 Execute the “HLR CFD Inactive MS Invocation” task (see 5.3.6).
- 2 Return to calling task via the PointOfReturn.

5.3.9 HLR CFD Busy MS Invocation

When the HLR detects a busy MS, it shall perform the following tasks:

- 1 Execute the “HLR CFD Inactive MS Invocation” task (see 5.3.6).
- 2 Return to calling task via the PointOfReturn.

5.3.10 HLR CFD No Answer MS Invocation

When the HLR detects a No Answer MS, it shall perform the following tasks:

- 1 Execute the “HLR CFD Inactive MS Invocation” task (see 5.3.6).
- 2 Return to calling task via the PointOfReturn.

5.3.11 HLR CFD Unroutable MS Invocation

When the HLR detects a call not reaching the MS, it shall perform the following tasks:

- 1 Execute the “HLR CFD Inactive MS Invocation” task (see 5.3.6).
- 2 Return to calling task via the PointOfReturn.

5.4 CALL FORWARDING NO ANSWER (CFNA)

5.4.1 HLR CFNA Registration

Upon request, the HLR shall do the following:

- 1 IF CFNA is authorized:
 - 1-1 IF the termination address is acceptable:
 - 1-1-1 Execute the “HLR SPINI Feature Request Invocation” task (see 5.21.4).
 - 1-1-2 IF the SPINI invocation *failed*:
 - 1-1-2-1 Include the FeatureResult parameter set to *Unsuccessful* to indicate unsuccessful feature operation.
 - 1-1-2-2 Return to the calling task via the PointOfReturn.

- 1 1-1-3 ENDIF.
2
3 1-1-4 Register the termination address as the CFNA forward-to number.
4 1-1-5 Optionally, include the AnnouncementCode parameter in the
5 AnnouncementList parameter set to an appropriate announcement.
6
7 1-1-6 Include the FeatureResult parameter set to *Successful* to indicate successful
8 feature operation.
9
10 1-1-7 IF activation is to occur with registration.
11 1-1-7-1 Optionally, include the AnnouncementCode parameter in the
12 AnnouncementList parameter set to an appropriate announcement.
13 1-1-7-2 Activate CFNA.
14 1-1-7-3 IF a courtesy call is to be performed:
15 1-1-7-3-1 Optionally, include the AnnouncementCode parameter in the
16 AnnouncementList parameter set to an appropriate announcement.
17 1-1-7-3-2 Set the selected forward-to number to the CFNA forward-to number.
18 1-1-7-3-3 Execute the “HLR Select Forward-To or Diversion Number Courtesy
19 Call Point of Return” task (see 6.1.1).
20 1-1-7-3-4 Include the DMH_RedirectionIndicator parameter set to *CFNA*.
21
22 1-1-7-4 ELSE:
23 1-1-7-4-1 Set PointOfReturn to *ToneTermination*.
24
25 1-1-7-5 ENDIF.
26 1-1-8 ENDIF.
27
28 1-2 ELSE:
29 1-2-1 Optionally, include the AnnouncementCode parameter in the
30 AnnouncementList parameter set to an appropriate announcement.
31 1-2-2 Include the FeatureResult parameter set to *Unsuccessful* to indicate
32 unsuccessful feature operation.
33 1-2-3 Set PointOfReturn to *ToneTermination*.
34
35 1-3 ENDIF.
36
37 2 ELSE:
38 2-1 Optionally, include the AnnouncementCode parameter in the AnnouncementList
39 parameter set to an appropriate announcement.
40 2-2 Include the FeatureResult parameter set to *Unsuccessful* to indicate unsuccessful
41 feature operation.
42 2-3 Set PointOfReturn to *ToneTermination*.
43
44 3 ENDIF.
45
46 4 Return to calling task via the PointOfReturn.
47
48
49

5.4.2 HLR CFNA De-Registration

Upon request, the HLR shall do the following:

- 1 IF CFNA is authorized:
1-1 De-register the CFNA forward-to number.
1-2 De-activate CFNA.

- 1-3 Optionally, include the *AnnouncementCode* parameter in the *AnnouncementList* parameter set to an appropriate announcement. 1
- 1-4 Include the *FeatureResult* parameter set to *Successful* to indicate successful feature operation. 2
- 2 ELSE: 3
- 2-1 Optionally, include the *AnnouncementCode* parameter in the *AnnouncementList* parameter set to an appropriate announcement. 4
- 2-2 Include the *FeatureResult* parameter set to *Unsuccessful* to indicate unsuccessful feature operation. 5
- 3 ENDIF. 6
- 4 Set *PointOfReturn* to *ToneTermination*. 7
- 5 Return to calling task via the *PointOfReturn*. 8

5.4.3 HLR CFNA Activation

Upon request, the HLR shall do the following: 9

- 1 IF CFNA is authorized: 10
- 1-1 IF the forward-to number is registered: 11
- 1-1-1 Optionally, include the *AnnouncementCode* parameter in the *AnnouncementList* parameter set to an appropriate announcement. 12
- 1-1-2 Include the *FeatureResult* parameter set to *Successful* to indicate successful feature operation. 13
- 1-1-3 Activate CFNA. 14
- 1-1-4 IF a courtesy call is to be performed: 15
- 1-1-4-1 Set the selected forward-to number to the CFNA forward-to number. 16
- 1-1-4-2 Execute the “HLR Select Forward-To or Diversion Number Courtesy Call Point of Return” task (see 6.1.1). 17
- 1-1-4-3 Include the *DMH_RedirectionIndicator* parameter set to *CFNA*. 18
- 1-1-5 ELSE: 19
- 1-1-5-1 Set *PointOfReturn* to *ToneTermination*. 20
- 1-1-6 ENDIF. 21
- 1-2 ELSE: 22
- 1-2-1 Optionally, include the *AnnouncementCode* parameter in the *AnnouncementList* parameter set to an appropriate announcement. 23
- 1-2-2 Include the *FeatureResult* parameter set to *Unsuccessful* to indicate unsuccessful feature operation. 24
- 1-2-3 Set *PointOfReturn* to *ToneTermination*. 25
- 1-3 ENDIF. 26
- 2 ELSE: 27
- 2-1 Optionally, include the *AnnouncementCode* parameter in the *AnnouncementList* parameter set to an appropriate announcement. 28
- 2-2 Include the *FeatureResult* parameter set to *Unsuccessful* to indicate unsuccessful feature operation. 29
- 2-3 Set *PointOfReturn* to *ToneTermination*. 30

- 3 ENDIF.
- 4 Return to calling task via the PointOfReturn.

5.4.4 HLR CFNA De-Activation

Upon request, the HLR shall do the following:

- 1 IF CFNA is authorized:
 - 1-1 De-activate CFNA.
 - 1-2 Optionally, include the AnnouncementCode parameter in the AnnouncementList parameter set to an appropriate announcement.
 - 1-3 Include the FeatureResult parameter set to *Successful* to indicate successful feature operation.
- 2 ELSE:
 - 2-1 Optionally, include the AnnouncementCode parameter in the AnnouncementList parameter set to an appropriate announcement.
 - 2-2 Include the FeatureResult parameter set to *Unsuccessful* to indicate unsuccessful feature operation.
- 3 ENDIF.
- 4 Set PointOfReturn to *ToneTermination*.
- 5 Return to calling task via the PointOfReturn.

5.4.5 HLR CFNA Incoming Call Invocation Task

When the HLR determines the needs for CFNA incoming call routing, it shall perform the following tasks:

- 1 IF CFNA is active and registered:
 - 1-1 IF the addressed MS is registered and active:
 - 1-1-1 IF DND is active OR IF CD is not active:
 - 1-1-1-1 Set the selected forward-to number to the CFNA forward-to number.
 - 1-1-1-2 Execute the “HLR Select Forward-To or Diversion Number Point of Return” task (see 6.1.2).
 - 1-1-1-3 Include the DMH_RedirectionIndicator parameter set to *CFNA*.
 - 1-1-2 ELSE:
 - 1-1-2-1 Continue processing the call toward the addressed MS.
 - 1-1-3 ENDIF.
 - 1-2 ELSE:
 - 1-2-1 Set the selected forward-to number to the CFNA forward-to number.
 - 1-2-2 Execute the “HLR Select Forward-To or Diversion Number Point of Return” task (see 6.1.2).
 - 1-2-3 Include the DMH_RedirectionIndicator parameter set to *CFNA*.
 - 1-3 ENDIF.
- 2 ELSE:
 - 2-1 Continue processing the call toward the addressed MS.

- 3 ENDIF.
- 4 Return to calling task via the PointOfReturn.

5.4.6 HLR CFNA Inactive MS Invocation

When the HLR detects an inactive MS, it shall perform the following tasks:

- 1 IF CFNA is active and registered:
 - 1-1 Set the selected forward-to number to the CFNA forward-to number.
 - 1-2 Execute the “HLR Select Forward-To or Diversion Number Point of Return” task (see 6.1.2).
 - 1-3 Include the DMH_RedirectionIndicator parameter set to *CFNA*.
- 2 ELSE:
 - 2-1 Continue processing the call.
- 3 ENDIF.
- 4 Return to calling task via the PointOfReturn.

5.4.7 HLR CFNA Unavailable MS Invocation

When the HLR detects an unavailable MS, it shall perform the following tasks:

- 1 Execute the “HLR CFNA Inactive MS Invocation” task (see 5.4.6).
- 2 Return to calling task via the PointOfReturn.

5.4.8 HLR CFNA Unresponsive MS Invocation

When the HLR detects an unresponsive MS, it shall perform the following tasks:

- 1 Execute the “HLR CFNA Inactive MS Invocation” task (see 5.4.6).
- 2 Return to calling task via the PointOfReturn.

5.4.9 HLR CFNA No Answer MS Invocation

When the HLR detects an No Answer MS, it shall perform the following tasks:

- 1 Execute the “HLR CFNA Inactive MS Invocation” task (see 5.4.6).
- 2 Return to calling task via the PointOfReturn.

5.4.10 HLR CFNA Unroutable MS Invocation

When the HLR detects a call not reaching the MS, it shall perform the following tasks:

- 1 Execute the “HLR CFNA Inactive MS Invocation” task (see 5.4.6).
- 2 Return to calling task via the PointOfReturn.

5.5 CALL FORWARDING UNCONDITIONAL (CFU)

5.5.1 HLR CFU Registration

Upon request, the HLR shall do the following:

- 1 IF CFU is authorized:
 - 1-1 IF the termination address is acceptable:
 - 1-1-1 Execute the “HLR SPINI Feature Request Invocation” task (see 5.21.4).
 - 1-1-2 IF the SPINI invocation *failed*:
 - 1-1-2-1 Include the FeatureResult parameter set to *Unsuccessful* to indicate unsuccessful feature operation.
 - 1-1-2-2 Return to the calling task via the PointOfReturn.
 - 1-1-3 ENDIF.
 - 1-1-4 Register the termination address as the CFU forward-to number.
 - 1-1-5 Optionally, include the AnnouncementCode parameter in the AnnouncementList parameter set to an appropriate announcement.
 - 1-1-6 Include the FeatureResult parameter set to *Successful* to indicate successful feature operation.
 - 1-1-7 IF activation is to occur with registration.
 - 1-1-7-1 Optionally, include the AnnouncementCode parameter in the AnnouncementList parameter set to an appropriate announcement.
 - 1-1-7-2 Activate CFU.
 - 1-1-7-3 IF a courtesy call is to be performed:
 - 1-1-7-3-1 Optionally, include the AnnouncementCode parameter in the AnnouncementList parameter set to an appropriate announcement.
 - 1-1-7-3-2 Set the selected forward-to number to the CFU forward-to number.
 - 1-1-7-3-3 Execute the “HLR Select Forward-To or Diversion Number Courtesy Call Point of Return” task (see 6.1.1).
 - 1-1-7-3-4 Include the DMH_RedirectionIndicator parameter set to *CFU*.
 - 1-1-7-4 ELSE:
 - 1-1-7-4-1 Set PointOfReturn to *ToneTermination*.
 - 1-1-7-5 ENDIF.
 - 1-1-8 ENDIF.
 - 1-2 ELSE:
 - 1-2-1 Optionally, include the AnnouncementCode parameter in the AnnouncementList parameter set to an appropriate announcement.
 - 1-2-2 Include the FeatureResult parameter set to *Unsuccessful* to indicate unsuccessful feature operation.
 - 1-2-3 Set PointOfReturn to *ToneTermination*.
 - 1-3 ENDIF.
- 2 ELSE:

- 2-1 Optionally, include the `AnnouncementCode` parameter in the `AnnouncementList` parameter set to an appropriate announcement. 1
- 2-2 Include the `FeatureResult` parameter set to *Unsuccessful* to indicate unsuccessful feature operation. 2
- 2-3 Set `PointOfReturn` to *ToneTermination*. 3
- 3 ENDIF. 4
- 4 Return to calling task via the `PointOfReturn`. 5

5.5.2 HLR CFU De-Registration

Upon request, the HLR shall do the following: 6

- 1 IF CFU is authorized: 7
- 1-1 De-register the CFU forward-to number. 8
- 1-2 De-activate CFU. 9
- 1-3 Optionally, include the `AnnouncementCode` parameter in the `AnnouncementList` parameter set to an appropriate announcement. 10
- 1-4 Include the `FeatureResult` parameter set to *Successful* to indicate successful feature operation. 11
- 2 ELSE: 12
- 2-1 Optionally, include the `AnnouncementCode` parameter in the `AnnouncementList` parameter set to an appropriate announcement. 13
- 2-2 Include the `FeatureResult` parameter set to *Unsuccessful* to indicate unsuccessful feature operation. 14
- 3 ENDIF. 15
- 4 Set `PointOfReturn` to *ToneTermination*. 16
- 5 Return to calling task via the `PointOfReturn`. 17

5.5.3 HLR CFU Activation

Upon request, the HLR shall do the following: 18

- 1 IF CFU is authorized: 19
- 1-1 IF the forward-to number is registered: 20
- 1-1-1 Optionally, include the `AnnouncementCode` parameter in the `AnnouncementList` parameter set to an appropriate announcement. 21
- 1-1-2 Include the `FeatureResult` parameter set to *Successful* to indicate successful feature operation. 22
- 1-1-3 Activate CFU. 23
- 1-1-4 IF a courtesy call is to be performed: 24
- 1-1-4-1 Optionally, include the `AnnouncementCode` parameter in the `AnnouncementList` parameter set to an appropriate announcement. 25
- 1-1-4-2 Set the selected forward-to number to the CFU forward-to number. 26
- 1-1-4-3 Execute the “HLR Select Forward-To or Diversion Number Courtesy Call Point of Return” task (see 6.1.1). 27
- 1-1-4-4 Include the `DMH_RedirectionIndicator` parameter set to *CFU*. 28

- 1-1-5 ELSE:
- 1-1-5-1 Set PointOfReturn to *ToneTermination*.
- 1-1-6 ENDIF.
- 1-2 ELSE:
- 1-2-1 Optionally, include the AnnouncementCode parameter in the AnnouncementList parameter set to an appropriate announcement.
- 1-2-2 Include the FeatureResult parameter set to *Unsuccessful* to indicate unsuccessful feature operation.
- 1-2-3 Set PointOfReturn to *ToneTermination*.
- 1-3 ENDIF.
- 2 ELSE:
- 2-1 Optionally, include the AnnouncementCode parameter in the AnnouncementList parameter set to an appropriate announcement.
- 2-2 Include the FeatureResult parameter set to *Unsuccessful* to indicate unsuccessful feature operation.
- 2-3 Set PointOfReturn to *ToneTermination*.
- 3 ENDIF.
- 4 Return to calling task via the PointOfReturn.

5.5.4 HLR CFU De-Activation

Upon request, the HLR shall do the following:

- 1 IF CFU is authorized:
- 1-1 De-activate CFU.
- 1-2 Optionally, include the AnnouncementCode parameter in the AnnouncementList parameter set to an appropriate announcement.
- 1-3 Include the FeatureResult parameter set to *Successful* to indicate successful feature operation.
- 2 ELSE:
- 2-1 Optionally, include the AnnouncementCode parameter in the AnnouncementList parameter set to an appropriate announcement.
- 2-2 Include the FeatureResult parameter set to *Unsuccessful* to indicate unsuccessful feature operation.
- 3 ENDIF.
- 4 Set PointOfReturn to *ToneTermination*.
- 5 Return to calling task via the PointOfReturn.

5.5.5 HLR CFU Incoming Call Invocation

When the HLR determines the needs for CFU incoming call routing, it shall perform the following tasks:

- 1 IF CFU is active and registered:
- 1-1 Set the selected forward-to number to the CFU forward-to number.

- 1-2 Execute the “HLR Select Forward-To or Diversion Number Point of Return” task (see 6.1.2). 1
2
- 1-3 Include the DMH_RedirectionIndicator parameter set to *CFU*. 3
4
- 1-4 IF DND is not active: 5
6
- 1-4-1 IF the addressed MS is registered and active: 7
- 1-4-1-1 Include the AlertCode parameter set to Call Forwarding Reminder Alert. 8
- 1-4-1-2 Execute the “HLR CNIP Redirecting Call Invocation” task (see 5.8.2). 9
10
- 1-4-1-3 IF the CFU reminder alert applies: 11
- 1-4-1-3-1 Spawn the “HLR Initiating an Information Directive” task (see 4.22.1). 12
13
- 1-4-1-4 ENDIF. 14
- 1-4-2 ENDIF. 15
16
- 1-5 ENDIF. 17
18
- 2 ELSE: 19
- 2-1 Continue processing the call toward the addressed MS. 20
21
- 3 ENDIF. 22
- 4 Return to calling task via the PointOfReturn. 23
24
25

5.5.6 HLR CFU Unconditional MS Invocation

When the HLR determines the needs for CFU unconditional call routing, it shall perform the following tasks:

- 1 Execute the “HLR CFU Incoming Call Invocation” task (see 5.5.5). 30
31
- 2 Return to calling task via the PointOfReturn. 32
33
34

5.6 CALL TRANSFER (CT)

Call Transfer is controlled by the call processing in the Anchor MSC in a manner consistent with *IS-53*. Call Transfer is enabled with a CallingFeaturesIndicator Feature Mask value in the subscriber’s service profile. 37
38
39
40

See 3.2.2. 41
42
43
44

5.7 CALL WAITING (CW)

5.7.1 HLR CW Activation

Upon request, the HLR shall do the following: 50
51

- 1 IF CW Demand Activation is authorized: 52
53
- 1-1 Optionally, include the AnnouncementCode parameter in the AnnouncementList parameter set to an appropriate announcement. 54
55
- 1-2 Include the FeatureResult parameter set to *Successful* to indicate successful feature operation. 56
57
58
59
60

- 1-3 Activate CW in the subscriber's service profile.
- 2 ELSE:
- 2-1 Optionally, include the `AnnouncementCode` parameter in the `AnnouncementList` parameter set to an appropriate announcement.
- 2-2 Include the `FeatureResult` parameter set to *Unsuccessful* to indicate unsuccessful feature operation.
- 3 ENDIF.
- 4 Set `PointOfReturn` to *ToneTermination*.
- 5 Return to calling task via the `PointOfReturn`.

5.7.2 HLR CW De-Activation

Upon request, the HLR shall do the following:

- 1 IF CW Demand Activation is authorized:
- 1-1 Optionally, include the `AnnouncementCode` parameter in the `AnnouncementList` parameter set to an appropriate announcement.
- 1-2 Include the `FeatureResult` parameter set to *Successful* to indicate successful feature operation.
- 1-3 De-activate CW in the subscriber's service profile.
- 2 ELSE:
- 2-1 Optionally, include the `AnnouncementCode` parameter in the `AnnouncementList` parameter set to an appropriate announcement.
- 2-2 Include the `FeatureResult` parameter set to *Unsuccessful* to indicate unsuccessful feature operation.
- 3 ENDIF.
- 4 Set `PointOfReturn` to *ToneTermination*.
- 5 Return to calling task via the `PointOfReturn`.

5.7.3 HLR CW Temporary De-Activation

Upon request, the HLR shall do the following:

- 1 IF CW Demand Cancellation is authorized:
- 1-1 Include `OneTimeFeatureIndicator` parameter with the Call Waiting for Future Incoming indicator set to *No CW*.
- 1-2 Optionally, include the `AnnouncementCode` parameter in the `AnnouncementList` parameter set to an appropriate announcement.
- 1-3 Include the `FeatureResult` parameter set to *Successful* to indicate successful feature operation.
- 1-4 Execute the "Termination Address Expansion" task (see 6.2.1).
- 2 ELSE:
- 2-1 Optionally, include the `AnnouncementCode` parameter in the `AnnouncementList` parameter set to an appropriate announcement.
- 2-2 Include the `FeatureResult` parameter set to *Unsuccessful* to indicate unsuccessful feature operation.

- 2-3 Set PointOfReturn to *ToneTermination*.
- 3 ENDIF.
- 4 Return to calling task via the PointOfReturn.

1
2
3
4
5
6
7
8
9
10
11
12
13
14
15
16
17
18
19
20
21
22
23
24
25
26
27
28
29
30
31
32
33
34
35
36
37
38
39
40
41
42
43
44
45
46
47
48
49
50
51
52
53
54
55
56
57
58
59
60

5.7.4 MSC CW Terminating Call Invocation

Upon CW invocation, the MSC shall do the following:

- 1 CASE Call Waiting for future incoming calls field of the OneTimeFeatureIndicator for the call in progress (as previously stored) OF:
 - 2 *No CW*:
 - 2-1 Return as *refused*.
 - 3 *Normal CW*:
 - 3-1 IF the OneTimeFeatureIndicator parameter's Call Waiting for Incoming Call indicator is set to *Normal CW* or *Priority CW*:
 - 3-1-1 Include the AnnouncementCode parameter within an AnnouncementList parameter set to the *CallWaitingTone*.
 - 3-1-2 Execute the "MSC CNIP Terminating Call Invocation" task (see 5.8.4).
 - 3-1-3 IF the MSC is the Serving MSC:
 - 3-1-3-1 Execute the "MSC Special MS Alerting" task (see 3.3.6).
 - 3-1-4 ELSE (the call has been handed off):
 - 3-1-4-1 Execute the "MSC Initiating an Information Forward" task (see 4.23.1).
 - 3-1-5 ENDIF.
 - 3-1-6 Return as *accepted*.
 - 3-2 ELSE:
 - 3-2-1 Return as *refused*.
 - 3-3 ENDIF.
 - 4 *Priority CW*:
 - 4-1 IF the OneTimeFeatureIndicator parameter's Call Waiting for Incoming Call indicator is set to *Priority CW*.
 - 4-1-1 Include the AnnouncementCode parameter within an AnnouncementList parameter set to the *CallWaitingTone*.
 - 4-1-2 Execute the "MSC CNIP Terminating Call Invocation" task (see 5.8.4).
 - 4-1-3 IF the MSC is the Serving MSC:
 - 4-1-3-1 Execute the "MSC Special MS Alerting" task (see 3.3.6).
 - 4-1-4 ELSE (the call has been handed off):
 - 4-1-4-1 Execute the "MSC Initiating an Information Forward" task (see 4.23.1).
 - 4-1-5 ENDIF.
 - 4-1-6 Return as *accepted*.
 - 4-2 ELSE:
 - 4-2-1 Return as *refused*.
 - 4-3 ENDIF.
 - 5 *DEFAULT (Ignore)*:

1 5-1 Return as *refused*.

2
3 6 ENDCASE.

4 5 **5.7.5 MSC CW Processing for Flash Request**

7 Call Waiting is controlled by the call processing in the Anchor MSC in a manner consistent
8 with *IS-53*. See 3.2.2.

9 10 11 12 **5.8 CALLING NUMBER IDENTIFICATION PRESENTATION (CNIP)**

13 14 15 **5.8.1 HLR CNIP Terminating Call Invocation**

16 Upon CNIP invocation, the HLR shall do the following:

17 1 IF the CallingPartyNumberDigits1 parameter is received:

18 1-1 Include the CallingPartyNumberString1 parameter set to indicate the identity of the
19 calling party.

20 2 ENDIF.

21 3 IF the CallingPartyNumberDigits2 parameter is received:

22 3-1 Include the CallingPartyNumberString2 parameter set to indicate the identity of the
23 calling party.

24 4 ENDIF.

25 5 IF the CallingPartySubaddress parameter is received:

26 5-1 Include the CallingPartySubaddress parameter set to indicate the subaddress of the
27 calling party.

28 6 ENDIF.

29 7 IF the call is being redirected by the HLR (e.g., CFB, CFD, CFNA, CFU, FA, or MAH,
30 PCA, or SCA):

31 7-1 Include the RedirectingNumberString parameter set to indicate the identity of the
32 last redirecting party (i.e., called mobile directory number or pilot directory
33 number, except for Call Delivery).

34 7-2 IF the redirecting party has a subaddress:

35 7-2-1 Include the RedirectingSubaddress parameter set to indicate the subaddress of
36 the last redirecting party.

37 7-3 ENDIF.

38 8 ELSEIF the RedirectingNumberDigits parameter is received:

39 8-1 Include the RedirectingNumberString parameter set to indicate the identity of the
40 last redirecting party.

41 8-2 IF the RedirectingSubaddress parameter is received:

42 8-2-1 Include the RedirectingSubaddress parameter set to indicate the subaddress of
43 the last redirecting party.

44 8-3 ENDIF.

45 9 ENDIF.

46 10 Return to the calling task.

5.8.2 HLR CNIP Redirecting Call Invocation

Upon CNIP invocation, the HLR shall do the following:

- 1 IF the CallingPartyNumberDigits1 parameter is received:
 - 1-1 Relay the CallingPartyNumberDigits1 parameter set to indicate the identity of the calling party.
- 2 ENDIF.
- 3 IF the CallingPartyNumberDigits2 parameter is received:
 - 3-1 Relay the CallingPartyNumberDigits2 parameter set to indicate the identity of the calling party.
- 4 ENDIF.
- 5 IF the CallingPartySubaddress parameter is received:
 - 5-1 Relay the CallingPartySubaddress parameter set to indicate the subaddress of the calling party.
- 6 ENDIF.
- 7 IF the call is being redirected by the HLR (e.g., CFB, CFD, CFNA, CFU, FA, or MAH, PCA, or SCA):
 - 7-1 Include the RedirectingNumberDigits parameter set to indicate the identity of the last redirecting party (i.e., called mobile directory number or pilot directory number, except for Call Delivery).
 - 7-2 IF the redirecting party has a subaddress:
 - 7-2-1 Include the RedirectingSubaddress parameter set to indicate the subaddress of the last redirecting party.
 - 7-3 ENDIF.
- 8 ELSEIF the RedirectingNumberDigits parameter is received:
 - 8-1 Relay the RedirectingNumberDigits parameter to indicate the identity of the last redirecting party.
 - 8-2 IF the RedirectingSubaddress parameter is received:
 - 8-2-1 Relay the RedirectingSubaddress parameter to indicate the subaddress of the last redirecting party.
 - 8-3 ENDIF.
- 9 ENDIF.
- 10 Return to the calling task.

5.8.3 MSC CNIP Originating Call Invocation

Upon request for a call origination, the MSC shall do the following:

- 1 IF the MS's MobileDirectoryNumber is available:
 - 1-1 Set the CallingPartyNumberDigits1 to the MS's MobileDirectoryNumber.
- 2 ELSE:
 - 2-1 Set the CallingPartyNumberDigits1 to the MS's MIN.
- 3 ENDIF.
- 4 Execute the "MSC CNIR Originating Call Invocation" task (see 5.9.3).
- 5 Return to the calling task.

5.8.4 MSC CNIP Terminating Call Invocation

Upon request, the MSC shall do the following:

- 1 IF the subscriber has CNIP1 or CNIP2 activated:
 - 1-1 IF the CallingPartyNumberString1 parameter is received:
 - 1-1-1 IF the CallingPartyNumberString1 is not presentation restricted:
 - 1-1-1-1 Include the CallingPartyNumberString1 parameter.
 - 1-1-1-2 IF the CallingPartySubaddress parameter is received:
 - 1-1-1-2-1 Include the CallingPartySubaddress parameter.
 - 1-1-1-3 ENDIF.
 - 1-1-1-4 IF the subscriber has CNIP2 activated:
 - 1-1-1-4-1 IF the CallingPartyNumberString2 parameter is received:
 - 1-1-1-4-1-1 IF the CallingPartyNumberString2 is not presentation restricted:
 - 1-1-1-4-1-1-1 Include the CallingPartyNumberString2 parameter.
 - 1-1-1-4-1-2 ELSE (presentation of calling number 2 is restricted):
 - 1-1-1-4-1-2-1 Include the CallingPartyNumberString2 parameter set to *Restricted*.
 - 1-1-1-4-1-3 ENDIF.
 - 1-1-1-4-2 ELSE (CallingPartyNumberString2 not received):
 - 1-1-1-4-2-1 Include the CallingPartyNumberString2 parameter set to *Unavailable*.
 - 1-1-1-4-3 ENDIF.
 - 1-1-1-5 ENDIF.
 - 1-1-2 ELSE (presentation of calling number 1 is restricted):
 - 1-1-2-1 Include the CallingPartyNumberString1 parameter set to *Restricted*.
 - 1-1-3 ENDIF.
 - 1-2 ELSE (CallingPartyNumberString1 not received):
 - 1-2-1 Include the CallingPartyNumberString1 parameter set to *Unavailable*.
 - 1-3 ENDIF.
 - 1-4 IF the RedirectingNumberString parameter is received:
 - 1-4-1 IF the RedirectingNumberString parameter is not presentation restricted:
 - 1-4-1-1 Include the RedirectingNumberString parameter.
 - 1-4-1-2 IF the RedirectingSubaddress parameter is received:
 - 1-4-1-2-1 Include the RedirectingSubaddress parameter.
 - 1-4-1-3 ENDIF.
 - 1-4-2 ELSE (presentation of redirecting number is restricted):
 - 1-4-2-1 Include the RedirectingNumberString parameter set to *Restricted*.
 - 1-4-3 ENDIF.
 - 1-5 ELSE:
 - 1-5-1 Include the RedirectingNumberString parameter set to *Unavailable*.
 - 1-6 ENDIF.

- 1-7 Return to the calling task as *accepted*.
- 2 ENDIF.
- 3 Return to the calling task as *refused*.

1
2
3
4
5
6
7
8
9
10
11
12
13
14
15
16
17
18
19
20
21
22
23
24
25
26
27
28
29
30
31
32
33
34
35
36
37
38
39
40
41
42
43
44
45
46
47
48
49
50
51
52
53
54
55
56
57
58
59
60

5.8.5 MSC CNIP Redirecting Call Invocation

Upon request for a call redirection, the redirecting MSC shall do the following:

- 1 IF the selected outgoing trunk is capable of transporting the CNI:
 - 1-1 IF the RedirectingNumberDigits parameter is received:
 - 1-1-1 Use the RedirectingNumberDigits parameter in the call setup request.
 - 1-2 ELSEIF the MS's MobileDirectoryNumber parameter is available:
 - 1-2-1 Set the RedirectingNumberDigits parameter set to the MS's MobileDirectoryNumber.
 - 1-3 ELSE:
 - 1-3-1 Set the RedirectingNumberDigits to the MS's MIN.
 - 1-4 ENDIF.
 - 1-5 IF CNIR is active in the OneTimeFeatureIndicator:
 - 1-5-1 Mark the RedirectingNumberDigits as *presentation restricted*.
 - 1-6 ENDIF.
 - 1-7 Relay the CallingPartyNumberDigits1, CallingPartyNumberDigits2, and CallingPartySubaddress as received and modified for the trunk signaling protocol used.
- 2 ENDIF.
- 3 Return to the calling task.

5.9 CALLING NUMBER IDENTIFICATION RESTRICTION (CNIR)

5.9.1 HLR CNIR Temporary Activation

Upon request, the HLR shall do the following:

- 1 IF CNIR Temporary Activation is authorized:
 - 1-1 Set the *Calling Number Identification Restriction* in the OneTimeFeatureIndicator parameter.
 - 1-2 Include the OneTimeFeatureIndicator parameter.
 - 1-3 Optionally, include the AnnouncementCode parameter in the AnnouncementList parameter set to an appropriate announcement.
 - 1-4 Include the FeatureResult parameter set to *Successful* to indicate successful feature operation.
 - 1-5 Execute the "Termination Address Expansion" task (see 6.2.1).
- 2 ELSE:
 - 2-1 Optionally, include the AnnouncementCode parameter in the AnnouncementList parameter set to an appropriate announcement.
 - 2-2 Set PointOfReturn to *ToneTermination*.

- 1 2-3 Include the FeatureResult parameter set to *Unsuccessful* to indicate unsuccessful
 2 feature operation.
 3 3 ENDIF.
 4 4 Return to calling task via the PointOfReturn.

5.9.2 HLR CNIR Temporary De-Activation

Upon request, the HLR shall do the following:

- 1 IF CNIR Temporary De-Activation is authorized:
- 1-1 Clear the *Calling Number Identification Restriction* in the OneTimeFeatureIndicator parameter.
- 1-2 Include the OneTimeFeatureIndicator parameter.
- 1-3 Optionally, include the AnnouncementCode parameter in the AnnouncementList parameter set to an appropriate announcement.
- 1-4 Include the FeatureResult parameter set to *Successful* to indicate successful feature operation.
- 1-5 Execute the “Termination Address Expansion” task (see 6.2.1).
- 2 ELSE:
- 2-1 Optionally, include the AnnouncementCode parameter in the AnnouncementList parameter set to an appropriate announcement.
- 2-2 Set PointOfReturn to *ToneTermination*.
- 2-3 Include the FeatureResult parameter set to *Unsuccessful* to indicate unsuccessful feature operation.
- 3 ENDIF.
- 4 Return to calling task via the PointOfReturn.

5.9.3 MSC CNIR Originating Call Invocation

Upon request, the MSC shall do the following:

- 1 IF *Calling Number Identification Restriction* is activated based upon the OneTimeFeatureIndicator:
- 1-1 Mark the CallingPartyNumberDigits1 as *Presentation Restricted*.
- 2 ELSE (CNIR is temporarily de-activated):
- 2-1 Mark the CallingPartyNumberDigits1 as *Presentation Allowed*.
- 3 ENDIF.
- 4 Return to the calling task.

5.9.4 MSC CNIR Redirecting Call Invocation

Upon request, the MSC shall do the following:

- 1 IF *Calling Number Identification Restriction* is activated based upon the OneTimeFeatureIndicator:
- 1-1 Mark the RedirectingNumberDigits as *Presentation Restricted*.
- 2 ELSE (CNIR is temporarily de-activated):

- 2-1 Mark the RedirectingNumberDigits as *Presentation Allowed*.
- 3 ENDIF.
- 4 Return to the calling task.

1
2
3
4
5
6
7
8
9
10
11
12
13
14
15
16
17
18
19
20
21
22
23
24
25
26
27
28
29
30
31
32
33
34
35
36
37
38
39
40
41
42
43
44
45
46
47
48
49
50
51
52
53
54
55
56
57
58
59
60

5.10 CONFERENCE CALLING (CC)

5.10.1 HLR CC Invocation

Upon request, the HLR shall do the following:

- 1 IF CC Invocation is authorized:
 - 1-1 IF the ConferenceCallingIndicator parameter is received:
 - 1-1-1 IF the number of conferees in the call is less than the authorized number of conferees.
 - 1-1-1-1 Optionally, include the AnnouncementCode parameter in the AnnouncementList parameter set to an appropriate announcement.
 - 1-1-1-2 Include the FeatureResult parameter set to *Successful* to indicate successful feature operation.
 - 1-1-1-3 Execute the “Termination Address Expansion” task (see 6.2.1).
 - 1-1-2 ELSE (number of conferees is greater than or equal to the authorized number):
 - 1-1-2-1 Optionally, include the AnnouncementCode parameter in the AnnouncementList parameter set to an appropriate announcement.
 - 1-1-2-2 Include the FeatureResult parameter set to *Unsuccessful* to indicate unsuccessful feature operation.
 - 1-1-2-3 Set the PointOfReturn to *ToneTermination* to prevent further address processing.
 - 1-1-3 ENDIF.
 - 1-2 ELSE (ConferenceCallingIndicator parameter not received, i.e., initial invocation):
 - 1-2-1 Optionally, include the AnnouncementCode parameter in the AnnouncementList parameter set to an appropriate announcement.
 - 1-2-2 Include the FeatureResult parameter set to *Successful* to indicate successful feature operation.
 - 1-2-3 Execute the “Termination Address Expansion” task (see 6.2.1).
 - 1-3 ENDIF.
 - 1-4 Include the ConferenceCallingIndicator parameter set to the maximum number of conferees allowed.
- 2 ELSE (CC is not authorized):
 - 2-1 Optionally, include the AnnouncementCode parameter in the AnnouncementList parameter set to an appropriate announcement.
 - 2-2 Include the FeatureResult parameter set to *Unsuccessful* to indicate unsuccessful feature operation.
 - 2-3 Set PointOfReturn to *ToneTermination*.
- 3 ENDIF.
- 4 Return to calling task via the PointOfReturn.

5.10.2 HLR CC Drop Last Party Invocation

Upon request, the HLR shall do the following:

- 1 IF the ConferenceCallingIndicator parameter is received (i.e., conference calling is invoked):
 - 1-1 Include the ActionCode parameter set to *Conference calling drop last party*.
 - 1-2 Optionally, include the AnnouncementCode parameter in the AnnouncementList parameter set to an appropriate announcement.
 - 1-3 Include the FeatureResult parameter set to *Successful* to indicate successful feature operation.
 - 1-4 Execute the “Termination Address Expansion” task (see 6.2.1).
- 2 ELSE:
 - 2-1 Optionally, include the AnnouncementCode parameter in the AnnouncementList parameter set to an appropriate announcement.
 - 2-2 Include the FeatureResult parameter set to *Unsuccessful* to indicate unsuccessful feature operation.
- 3 ENDIF.
- 4 Set PointOfReturn to *ToneTermination*.
- 5 Return to calling task via the PointOfReturn.

5.10.3 MSC CC Invocation

Conference Calling is controlled by the call processing in the Anchor MSC in a manner consistent with *IS-53* Conference Calling is started with the following procedure and remain in effect until the subscriber disconnects. See 3.2.2.

- 1 Put the call in a conference calling mode.
- 2 Reserve the maximum number of conference ports to be the minimum of the received ConferenceCallingIndicator parameter, the number of ports allowed by the serving system, and the number of ports available.
- 3 Return to the calling task.

5.11 DO NOT DISTURB (DND)

5.11.1 HLR DND Activation

Upon request, the HLR shall do the following:

- 1 IF DND Activation is authorized:
 - 1-1 Set the DND activation indication.
 - 1-2 Optionally, include the AnnouncementCode parameter in the AnnouncementList parameter set to an appropriate announcement.
 - 1-3 Include the FeatureResult parameter set to *Successful* to indicate successful feature operation.
 - 1-4 Set PointOfReturn to *ToneTermination*.
- 2 ELSE:

- 2-1 Optionally, include the `AnnouncementCode` parameter in the `AnnouncementList` parameter set to an appropriate announcement. 1
- 2-2 Include the `FeatureResult` parameter set to *Unsuccessful* to indicate unsuccessful feature operation. 2
- 2-3 Set `PointOfReturn` to *ToneTermination*. 3
- 3 ENDIF. 4
- 4 Return to calling task via the `PointOfReturn`. 5

5.11.2 HLR DND De-Activation

Upon request, the HLR shall do the following: 6

- 1 IF DND De-Activation is authorized: 7
- 1-1 Clear the DND activation indication. 8
- 1-2 Optionally, include the `AnnouncementCode` parameter in the `AnnouncementList` parameter set to an appropriate announcement. 9
- 1-3 Include the `FeatureResult` parameter set to *Successful* to indicate successful feature operation. 10
- 1-4 Set `PointOfReturn` to *ToneTermination*. 11
- 2 ELSE: 12
- 2-1 Optionally, include the `AnnouncementCode` parameter in the `AnnouncementList` parameter set to an appropriate announcement. 13
- 2-2 Include the `FeatureResult` parameter set to *Unsuccessful* to indicate unsuccessful feature operation. 14
- 2-3 Set `PointOfReturn` to *ToneTermination*. 15
- 3 ENDIF. 16
- 4 Return to calling task via the `PointOfReturn`. 17

5.11.3 HLR DND Incoming Call Invocation

Upon request, the HLR shall do the following: 18

- 1 IF DND is active: 19
- 1-1 Optionally, include the `AnnouncementCode` parameter in the `AnnouncementList` parameter set to an appropriate announcement. 20
- 1-2 Include the `AccessDeniedReason` parameter set to *Inactive*. 21
- 1-3 Set `PointOfReturn` to *ToneTermination*. 22
- 2 ELSE: 23
- 2-1 Continue processing the call toward the addresses `MS._` 24
- 3 ENDIF. 25
- 4 Return to calling task via the `PointOfReturn`. 26

5.12 FLE IBLE ALERTING (FA)

5.12.1 HLR FA Membership Activation

Upon request, the HLR shall do the following:

- 1 IF an FA pilot directory number is specified:
 - 1-1 IF the MS is a member of the specified FA group:
 - 1-1-1 IF FA Membership activation on that group is authorized:
 - 1-1-1-1 Activate the subscriber's membership in the selected FA group.
 - 1-1-1-2 Optionally, include the AnnouncementCode parameter in the AnnouncementList parameter set to an appropriate announcement.
 - 1-1-1-3 Include the FeatureResult parameter set to *Success*.
 - 1-1-2 ELSE (subscriber is not authorized):
 - 1-1-2-1 Optionally, include the AnnouncementCode parameter in the AnnouncementList parameter set to an appropriate announcement.
 - 1-1-2-2 Include the FeatureResult parameter set to *Unsuccessful* to indicate unsuccessful feature operation.
 - 1-1-3 ENDIF.
 - 1-2 ELSE (subscriber is not a member of the group):
 - 1-2-1 Optionally, include the AnnouncementCode parameter in the AnnouncementList parameter set to an appropriate announcement.
 - 1-2-2 Include the FeatureResult parameter set to *Unsuccessful* to indicate unsuccessful feature operation.
 - 1-3 ENDIF.
- 2 ELSEIF no FA pilot directory number is specified (to select the default FA group):
 - 2-1 IF FA Membership activation on that group is authorized:
 - 2-1-1 Optionally, include the AnnouncementCode parameter in the AnnouncementList parameter set to an appropriate announcement.
 - 2-1-2 Activate the subscriber's membership in the default FA group.
 - 2-1-3 Include the FeatureResult parameter set to *Successful* to indicate successful feature operation.
 - 2-2 ELSE (subscriber is not authorized):
 - 2-2-1 Optionally, include the AnnouncementCode parameter in the AnnouncementList parameter set to an appropriate announcement.
 - 2-2-2 Include the FeatureResult parameter set to *Unsuccessful* to indicate unsuccessful feature operation.
 - 2-3 ENDIF.
- 3 ELSE (the subscriber dialed a bad directory number):
 - 3-1 Optionally, include the AnnouncementCode parameter in the AnnouncementList parameter set to an appropriate announcement.
 - 3-2 Include the FeatureResult parameter set to *Unsuccessful* to indicate unsuccessful feature operation.

- 4 ENDIF. 1
 5 Return to calling task via the PointOfReturn. 2

5.12.2 HLR FA Membership De-Activation 3

Upon request, the HLR shall do the following: 4

- 1 IF an FA pilot directory number is specified: 5
 1-1 IF the MS is a member of the specified FA group: 6
 1-1-1 IF FA Membership de-activation on that group is authorized: 7
 1-1-1-1 Optionally, include the AnnouncementCode parameter in the 8
 AnnouncementList parameter set to an appropriate announcement. 9
 1-1-1-2 De-activate the subscriber's membership in the selected FA group. 10
 1-1-1-3 Include the FeatureResult parameter set to *Successful* to indicate 11
 successful feature operation. 12
 1-1-2 ELSE (subscriber is not authorized): 13
 1-1-2-1 Optionally, include the AnnouncementCode parameter in the 14
 AnnouncementList parameter set to an appropriate announcement. 15
 1-1-2-2 Include the FeatureResult parameter set to *Unsuccessful* to indicate 16
 unsuccessful feature operation. 17
 1-1-3 ENDIF. 18
 1-2 ELSE (subscriber is not a member of the group): 19
 1-2-1 Optionally, include the AnnouncementCode parameter in the 20
 AnnouncementList parameter set to an appropriate announcement. 21
 1-2-2 Include the FeatureResult parameter set to *Unsuccessful* to indicate 22
 unsuccessful feature operation. 23
 1-3 ENDIF. 24
 2 ELSEIF no FA pilot directory number is specified (to select the default FA group): 25
 2-1 IF FA Membership de-activation on that group is authorized: 26
 2-1-1 Optionally, include the AnnouncementCode parameter in the 27
 AnnouncementList parameter set to an appropriate announcement. 28
 2-1-2 De-activate the subscriber's membership in the default FA group. 29
 2-1-3 Include the FeatureResult parameter set to *Successful* to indicate successful 30
 feature operation. 31
 2-2 ELSE (subscriber is not authorized): 32
 2-2-1 Optionally, include the AnnouncementCode parameter in the 33
 AnnouncementList parameter set to an appropriate announcement. 34
 2-2-2 Include the FeatureResult parameter set to *Unsuccessful* to indicate 35
 unsuccessful feature operation. 36
 2-3 ENDIF. 37
 3 ELSE (the subscriber dialed a bad directory number): 38
 3-1 Optionally, include the AnnouncementCode parameter in the 39
 AnnouncementList parameter set to an appropriate announcement. 40
 3-1-1 Include the FeatureResult parameter set to *Unsuccessful* to indicate 41
 unsuccessful feature operation. 42

- 1 3-2 ENDIF.
 2
 3 4 ENDIF.
 4 5 Return to calling task via the PointOfReturn.
 5

5.12.3 HLR FA Incoming Call Invocation

When the HLR determines the needs for FA incoming call routing, it shall perform the following tasks:

- 1 Optionally, store the BillingID parameter and correlate it to the other stored information about this call.
 2 Set the access denied reason to the lowest priority reason.
 3 (Execute Incoming Call Feature Processes applicable to the FA Group as a whole:)
 4 Include the OneTimeFeatureIndicator parameter set for the features of the FA Group.
 5 Include the TerminationTriggers parameter set for the features of the FA Group.
 6 IF the received TransactionCapability parameter indicates that the Originating MSC is termination capable:
 6-1 Clear the first waitable member indication.
 6-2 FOR all active members of the FA Group (optionally excluding a member originating the call):
 6-2-1 IF the member is an MS on the current HLR:
 6-2-1-1 IF the MS is registered to the requesting system:
 6-2-1-1-1 IF the MS is active:
 6-2-1-1-1-1 Include the ElectronicSerialNumber parameter set to identify the called MS within the LocalTermination parameter for this MS.
 6-2-1-1-1-2 Include the MobileIdentificationNumber parameter set to identify the called MS within the LocalTermination parameter for this MS.
 6-2-1-1-1-3 Include the TerminationTreatment parameter set to *MS Termination* within the LocalTermination parameter for this MS.
 6-2-1-1-1-4 IF custom alerting is applicable for the call:
 6-2-1-1-1-4-1 Include the AlertCode parameter set appropriately within the LocalTermination parameter for this MS.
 6-2-1-1-1-5 ENDIF.
 6-2-1-1-1-6 IF triggers should be set for this terminating leg at the originating switch for the redirecting call:
 6-2-1-1-1-6-1 Include the TerminationTriggers parameter within the LocalTermination parameter for this MS.
 6-2-1-1-1-7 ENDIF.
 6-2-1-1-1-8 Store the LocalTermination parameter within the TerminationList parameter.
 6-2-1-1-2 ELSE (The MS cannot be accessed):
 6-2-1-1-2-1 IF *Inactive* is a higher priority reason than the current access denied reason:
 6-2-1-1-2-1-1 Set the access denied reason to *Inactive*.

| | | |
|---------------------|--|----|
| 6-2-1-1-2-2 | ENDIF. | 1 |
| 6-2-1-1-3 | ENDIF. | 2 |
| 6-2-1-2 | ELSE (the member is an MS registered on another system): | 3 |
| 6-2-1-2-1 | IF the MS is active: | 4 |
| 6-2-1-2-1-1 | Include the TerminationTreatment parameter set to <i>MSTermination</i> . | 5 |
| 6-2-1-2-1-2 | Include the OneTimeFeatureIndicator parameter set appropriately. | 6 |
| 6-2-1-2-1-3 | IF custom alerting is applicable for the call: | 7 |
| 6-2-1-2-1-3-1 | Include the AlertCode parameter set appropriately. | 8 |
| 6-2-1-2-1-4 | ENDIF. | 9 |
| 6-2-1-2-1-5 | IF triggers should be set for the terminating party at the terminating switch for this call: | 10 |
| 6-2-1-2-1-5-1 | Include the TerminationTriggers parameter. | 11 |
| 6-2-1-2-1-6 | ENDIF. | 12 |
| 6-2-1-2-1-7 | Execute the “HLR Initiating a Routing Request” task (see 4.41.1). | 13 |
| 6-2-1-2-1-8 | IF an AccessDeniedReason parameter is received AND IF it can be acted upon: | 14 |
| 6-2-1-2-1-8-1 | IF Digits (Destination) parameter is received: | 15 |
| 6-2-1-2-1-8-1-1 | Relay the AccessDeniedReason parameter in the IntersystemTermination parameter. | 16 |
| 6-2-1-2-1-8-1-2 | Relay other relevant received parameters within the IntersystemTermination parameter. | 17 |
| 6-2-1-2-1-8-1-3 | Store the IntersystemTermination parameter within the TerminationList parameter | 18 |
| 6-2-1-2-1-8-2 | ELSE (no Digits (Destination) parameter is received with the AccessDeniedReason): | 19 |
| 6-2-1-2-1-8-2-1 | IF the AccessDeniedReason parameter indicates <i>Busy</i> : | 20 |
| 6-2-1-2-1-8-2-1-1 | IF the FA group is a Single User Group. | 21 |
| 6-2-1-2-1-8-2-1-1-1 | Discard the AnnouncementList and TerminationList parameters. | 22 |
| 6-2-1-2-1-8-2-1-1-2 | Discard the parameters stored with the BillingID parameter. | 23 |
| 6-2-1-2-1-8-2-1-1-3 | Relay the AccessDeniedReason parameter. | 24 |
| 6-2-1-2-1-8-2-1-1-4 | Set the PointOfReturn to <i>ToneTermination</i> . | 25 |
| 6-2-1-2-1-8-2-1-1-5 | Return to calling task via the PointOfReturn. | 26 |
| 6-2-1-2-1-8-2-1-2 | ELSE (the FA group is a Multiple User Group): | 27 |
| 6-2-1-2-1-8-2-1-2-1 | Set the access denied reason to <i>Busy</i> . | 28 |
| 6-2-1-2-1-8-2-1-3 | ENDIF. | 29 |
| 6-2-1-2-1-8-2-2 | ELSE (member is other than Busy): | 30 |
| | | 31 |
| | | 32 |
| | | 33 |
| | | 34 |
| | | 35 |
| | | 36 |
| | | 37 |
| | | 38 |
| | | 39 |
| | | 40 |
| | | 41 |
| | | 42 |
| | | 43 |
| | | 44 |
| | | 45 |
| | | 46 |
| | | 47 |
| | | 48 |
| | | 49 |
| | | 50 |
| | | 51 |
| | | 52 |
| | | 53 |
| | | 54 |
| | | 55 |
| | | 56 |
| | | 57 |
| | | 58 |
| | | 59 |
| | | 60 |

| | | |
|----|---------------------|--|
| 1 | 6-2-1-2-1-8-2-2-1 | IF the <code>AccessDeniedReason</code> is a higher priority reason than the current access denied reason: |
| 2 | | |
| 3 | | |
| 4 | 6-2-1-2-1-8-2-2-1-1 | Set the access denied reason to received <code>AccessDeniedReason</code> parameter. |
| 5 | | |
| 6 | | |
| 7 | 6-2-1-2-1-8-2-2-2 | ENDIF. |
| 8 | 6-2-1-2-1-8-2-3 | ENDIF. |
| 9 | 6-2-1-2-1-8-3 | ENDIF. |
| 10 | | |
| 11 | 6-2-1-2-1-9 | ELSEIF <code>Digits (Destination)</code> is received (without an <code>AccessDeniedReason</code> parameter OR the <code>AccessDeniedReason</code> parameter cannot be acted upon): |
| 12 | | |
| 13 | | |
| 14 | 6-2-1-2-1-9-1 | IF a <code>ConditionallyDeniedReason</code> parameter is received and it can be acted upon by the HLR: |
| 15 | | |
| 16 | | |
| 17 | 6-2-1-2-1-9-1-1 | IF waitable member should be included in first round alerting: |
| 18 | | |
| 19 | 6-2-1-2-1-9-1-1-1 | Include the <code>Destination (Digits)</code> parameter within the <code>IntersystemTermination</code> parameter for this member. |
| 20 | | |
| 21 | | |
| 22 | | |
| 23 | 6-2-1-2-1-9-1-1-2 | Include other relevant parameters within the <code>IntersystemTermination</code> parameter for this member. |
| 24 | | |
| 25 | 6-2-1-2-1-9-1-1-3 | Store the <code>IntersystemTermination</code> parameter within the <code>TerminationList</code> parameter |
| 26 | | |
| 27 | | |
| 28 | 6-2-1-2-1-9-1-2 | ELSEIF the member should be waited upon: |
| 29 | 6-2-1-2-1-9-1-2-1 | Store the current member in the waitable list. |
| 30 | | |
| 31 | 6-2-1-2-1-9-1-3 | ENDIF. |
| 32 | 6-2-1-2-1-9-2 | ELSE (the <code>ConditionallyDeniedReason</code> parameter is irrelevant to the HLR): |
| 33 | | |
| 34 | 6-2-1-2-1-9-2-1 | Include the <code>Destination (Digits)</code> parameter within the <code>IntersystemTermination</code> parameter for this member. |
| 35 | | |
| 36 | | |
| 37 | 6-2-1-2-1-9-2-2 | Include other relevant parameters within the <code>IntersystemTermination</code> parameter for this member. |
| 38 | | |
| 39 | 6-2-1-2-1-9-2-3 | Store the <code>IntersystemTermination</code> parameter within the <code>TerminationList</code> parameter |
| 40 | | |
| 41 | | |
| 42 | 6-2-1-2-1-9-3 | ENDIF. |
| 43 | 6-2-1-2-1-10 | ELSE (The MS cannot be accessed; no <code>Digits</code> or <code>AccessDeniedReason</code> parameter received): |
| 44 | | |
| 45 | | |
| 46 | 6-2-1-2-1-10-1 | IF <i>Error</i> is a higher priority reason than the current access denied reason: |
| 47 | | |
| 48 | 6-2-1-2-1-10-1-1 | Set the access denied reason to <i>Error</i> . |
| 49 | 6-2-1-2-1-10-2 | ENDIF. |
| 50 | | |
| 51 | 6-2-1-2-1-11 | ENDIF. |
| 52 | 6-2-1-2-2 | ELSE (The MS is not active): |
| 53 | | |
| 54 | 6-2-1-2-2-1 | IF <i>Inactive</i> is a higher priority reason than the current access denied reason: |
| 55 | | |
| 56 | 6-2-1-2-2-1-1 | Set the access denied reason to <i>Inactive</i> . |
| 57 | 6-2-1-2-2-2 | ENDIF. |
| 58 | | |
| 59 | | |
| 60 | | |

| | | |
|-----------|---|----|
| 6-2-1-2-3 | ENDIF. | 1 |
| 6-2-1-3 | ENDIF. | 2 |
| 6-2-2 | ELSE (member is not homed to this HLR, treat it as a PSTN termination): | 3 |
| 6-2-2-1 | IF this leg requires special termination trigger treatment: | 4 |
| 6-2-2-1-1 | Include the TerminationTriggers parameter setting desired triggers for this leg within a PSTNTermination parameter for this member. | 5 |
| 6-2-2-2 | ENDIF. | 6 |
| 6-2-2-3 | Include the relevant parameters within a PSTNTermination parameter for this member. | 7 |
| 6-2-2-4 | Store the PSTNTermination parameter within the TerminationList parameter | 8 |
| 6-2-3 | ENDIF. | 9 |
| 6-2-4 | IF the number of terminations in the TerminationList equals the number of terminations allowed in the TransactionCapability. | 10 |
| 6-2-4-1 | Exit this loop (for the active members of the group). | 11 |
| 6-2-5 | ENDIF. | 12 |
| 6-3 | ENDFOR. | 13 |
| 6-4 | IF at least one termination is in the TerminationList: | 14 |
| 6-4-1 | Include the GroupInformation parameter set to relevant information about the FA group. | 15 |
| 6-4-2 | IF no answer timing applies: | 16 |
| 6-4-2-1 | Include the NoAnswerTime parameter set to the time to alert a member. | 17 |
| 6-4-3 | ENDIF. | 18 |
| 6-4-4 | Include the TerminationTriggers parameter set to the triggers that apply to the FA group as a whole. | 19 |
| 6-4-5 | Include the OneTimeFeatureIndicator parameter that apply to the FA group as a whole. | 20 |
| 6-4-6 | Optionally, include the AnnouncementCode parameter in the AnnouncementList parameter set to an appropriate call progress announcement. | 21 |
| 6-4-7 | Set the PointOfReturn to <i>Multiple Termination</i> . | 22 |
| 6-5 | ELSE (no terminations are in the TerminationList): | 23 |
| 6-5-1 | IF one or more members are waitable: | 24 |
| 6-5-1-1 | Include the relevant parameters for the waitable member(s) for each member within the appropriate termination parameter (i.e., LocalTermination, PSTNTermination, or IntersystemTermination parameter) within a common TerminationList parameter. | 25 |
| 6-5-1-2 | Set the PointOfReturn to <i>Multiple Termination</i> . | 26 |
| 6-5-2 | ELSE: | 27 |
| 6-5-2-1 | Include the AccessDeniedReason parameter set to the access denied reason. | 28 |
| 6-5-2-2 | Set the PointOfReturn to <i>ToneTermination</i> . | 29 |
| 6-5-3 | ENDIF. | 30 |
| 6-6 | ENDIF. | 31 |
| | | 32 |
| | | 33 |
| | | 34 |
| | | 35 |
| | | 36 |
| | | 37 |
| | | 38 |
| | | 39 |
| | | 40 |
| | | 41 |
| | | 42 |
| | | 43 |
| | | 44 |
| | | 45 |
| | | 46 |
| | | 47 |
| | | 48 |
| | | 49 |
| | | 50 |
| | | 51 |
| | | 52 |
| | | 53 |
| | | 54 |
| | | 55 |
| | | 56 |
| | | 57 |
| | | 58 |
| | | 59 |
| | | 60 |

- 1 7 ELSE (FA routing is not possible from this MSC):
 2
 3 7-1 IF a single member is still to be supported:
 4 7-1-1 Include the relevant parameters for a single member of a group. (Other
 5 procedures may be required to obtain these parameters, such as, “HLR CD
 6 Incoming Call Invocation” task.)
 7 7-2-2 Set the PointOfReturn appropriately.
 8
 9 7-2 ELSE (single member is not supported):
 10 7-2-1 Include the AnnouncementCode parameter in the AnnouncementList
 11 parameter set appropriately (e.g., for an inaccessible subscriber).
 12 7-2-2 Set the PointOfReturn to *ToneTermination*.
 13 7-3 ENDIF.
 14 7-3 ENDIF.
 15 8 ENDIF.
 16 9 Return to calling task via the PointOfReturn.
 17
 18
 19

5.12.4 HLR FA Revertive Call Invocation

21 Upon request, the HLR shall perform the following tasks:

- 22
 23 1 Execute “HLR FA Incoming Call Invocation” task (see 5.12.3).
 24 2 Return to calling task via the PointOfReturn.
 25
 26
 27

5.12.5 HLR FA Busy MS Invocation

28 When the HLR detects a busy MS¹, it shall perform the following tasks:

- 29
 30 1 IF the HLR maintains context information for an FA call:
 31 1-1 IF the BillingID parameter from the request matches a current FA call:
 32 1-1-1 IF the FA group is a Single User Group:
 33 1-1-1-1 IF the group features apply based on the context of the transaction:
 34 1-1-1-1-1 Execute service specific logic applicable to the group as a whole. The
 35 interaction between FA and other features is beyond the scope of this
 36 Standard.
 37 1-1-1-1-2 IF the request came from the Originating MSC:
 38 1-1-1-1-2-1 Include the ActionCode parameter set appropriately (e.g.,
 39 *Disconnect all call legs*).
 40 1-1-1-1-3 ENDIF.
 41 1-1-1-1-4 Include the AccessDeniedReason parameter set appropriately (e.g.,
 42 *Busy*).
 43 1-1-1-2 ELSE (individual feature operation):
 44 1-1-1-2-1 Execute service specific logic applicable to the individual subscriber.
 45 The interaction between FA and other features is beyond the scope of
 46 this Standard.
 47
 48
 49
 50
 51
 52
 53

54
 55 ¹This task is used for multiple detecte conditions, so the treatment should be changes
 56 appropriately.
 57
 58
 59
 60

| | | |
|-------------|---|----|
| 1-1-1-2-2 | Include the ActionCode parameter set appropriately (e.g., <i>Disconnect call leg</i>). | 1 |
| | | 2 |
| 1-1-1-3 | ENDIF. | 3 |
| | | 4 |
| 1-1-2 | ELSE (the FA group is a Multiple User Group): | 5 |
| | | 6 |
| 1-1-2-1 | If group features apply based upon the context of the transaction: | 7 |
| 1-1-2-1-1 | Execute service specific logic applicable to the group as a whole. The interaction between FA and other features is beyond the scope of this Standard. | 8 |
| | | 9 |
| | | 10 |
| 1-1-2-1-2 | IF the request came from the Originating MSC: | 11 |
| | | 12 |
| 1-1-2-1-2-1 | Include the ActionCode parameter set appropriately (e.g., <i>Disconnect all call legs</i>). | 13 |
| | | 14 |
| 1-1-2-1-3 | ENDIF. | 15 |
| | | 16 |
| 1-1-2-1-4 | Include the AccessDeniedReason parameter set appropriately (e.g., <i>Busy</i>). | 17 |
| | | 18 |
| 1-1-2-2 | ELSE (individual feature operation): | 19 |
| 1-1-2-2-1 | Execute service specific logic applicable to the individual subscriber. The interaction between FA and other features is beyond the scope of this Standard. | 20 |
| | | 21 |
| | | 22 |
| | | 23 |
| 1-1-2-2-2 | Include the ActionCode parameter set appropriately (e.g., <i>Disconnect call leg</i>). | 24 |
| | | 25 |
| 1-1-2-3 | ENDIF. | 26 |
| | | 27 |
| 1-1-3 | ENDIF. | 28 |
| | | 29 |
| 1-2 | ELSE (invalid or unknown BillingID parameter): | 30 |
| 1-2-1 | Continue processing the call. | 31 |
| 1-3 | ENDIF. | 32 |
| | | 33 |
| 2 | ELSE (the HLR does not use context information for an FA call): | 34 |
| 2-1 | IF the FA pilot directory number can be determined from a received PilotNumber parameter. | 35 |
| | | 36 |
| 2-1-1 | IF the FA group is a Single User Group: | 37 |
| | | 38 |
| 2-1-1-1 | IF the GroupInformation parameter is received: | 39 |
| 2-1-1-1-1 | Execute service specific logic applicable to the FA Group as a whole. The interaction between FA and other features is beyond the scope of this Standard. | 40 |
| | | 41 |
| | | 42 |
| 2-1-1-2 | ELSEIF the LegInformation parameter is received: | 43 |
| | | 44 |
| 2-1-1-2-1 | Execute service specific logic applicable to the individual subscriber. The interaction between FA and other features is beyond the scope of this Standard. | 45 |
| | | 46 |
| | | 47 |
| 2-1-1-3 | ENDIF. | 48 |
| | | 49 |
| 2-1-1-4 | IF the request came from the Originating MSC: | 50 |
| | | 51 |
| 2-1-1-4-1 | Include the ActionCode parameter set appropriately (e.g., <i>Disconnect all call legs</i>). | 52 |
| | | 53 |
| 2-1-1-5 | ENDIF. | 54 |
| | | 55 |
| 2-1-1-6 | Include the AccessDeniedReason parameter set appropriately (e.g., <i>Busy</i>). | 56 |
| | | 57 |
| 2-1-2 | ELSE (the FA group is a Multiple User Group): | 58 |
| | | 59 |
| | | 60 |

1 2-1-2-1 IF the GroupInformation parameter is received:
2
3 2-1-2-1-1 Execute service specific logic applicable to the group as a whole. The
4 interaction between FA and other features is beyond the scope of this
5 Standard.
6 2-1-2-1-2 IF the request came from the Originating MSC:
7 2-1-2-1-2-1 Include the ActionCode parameter set appropriately (e.g.,
8 *Disconnect all call legs*).
9
10 2-1-2-1-3 ENDIF.
11 2-1-2-1-4 Include the AccessDeniedReason parameter set appropriately (e.g.,
12 *Busy*).
13
14 2-1-2-2 ELSEIF the LegInformation parameter is received:
15 2-1-2-2-1 Execute service specific logic applicable to the individual subscriber.
16 The interaction between FA and other features is beyond the scope of
17 this Standard.
18
19 2-1-2-3 ENDIF.
20 2-1-3 ENDIF.
21 2-2 ELSE (PilotNumber does not indicate an FA pilot directory number):
22 2-2-1 Continue processing the call.
23 2-3 ENDIF.
24 3 ENDIF.
25 4 Return to the calling task.

5.12.6 HLR FA Inactive MS Invocation

When the HLR detects an inactive MS, it shall perform the following tasks:

- 1 Execute the “HLR FA Busy MS Invocation” task (see 5.12.5).
- 2 Return to the calling task.

5.12.7 HLR FA Unavailable MS Invocation

When the HLR detects an unavailable MS, it shall perform the following tasks:

- 1 Execute the “HLR FA Busy MS Invocation” task (see 5.12.5).
- 2 Return to the calling task.

5.12.8 HLR FA Unresponsive MS Invocation

When the HLR detects an MS that does not respond to paging, it shall perform the following tasks:

- 1 Execute the “HLR FA Busy MS Invocation” task (see 5.12.5).
- 2 Return to the calling task.

5.12.9 HLR FA No Answer MS Invocation

When the HLR detects an MS that does not answer, it shall perform the following tasks:

- 1 Execute the “HLR FA Busy MS Invocation” task (see 5.12.5).
- 2 Return to the calling task.

5.12.10 HLR FA Unroutable MS Invocation

When the HLR detects a routing failure to an MS, it shall perform the following tasks:

- 1 Execute the “HLR FA Busy MS Invocation” task (see 5.12.5).
- 2 Return to the calling task.

5.13 MESSAGE WAITING NOTIFICATION (MWN)

5.13.1 HLR MWN Demand Pip Tone Activation

Upon request, the HLR shall do the following:

- 1 IF MWN Demand Pip Tone Activation is authorized:
 - 1-1 Optionally, include the *AnnouncementCode* parameter in the *AnnouncementList* parameter set to an appropriate announcement.
 - 1-2 Include the *FeatureResult* parameter set to *Successful* to indicate successful feature operation.
 - 1-3 Activate MWN Pip Tone in the subscriber’s service profile.
- 2 ELSE:
 - 2-1 Optionally, include the *AnnouncementCode* parameter in the *AnnouncementList* parameter set to an appropriate announcement.
 - 2-2 Include the *FeatureResult* parameter set to *Unsuccessful* to indicate unsuccessful feature operation.
- 3 ENDIF.
- 4 Set *PointOfReturn* to *ToneTermination*.
- 5 Return to calling task via the *PointOfReturn*.

5.13.2 HLR MWN Demand Pip Tone De-Activation

Upon request, the HLR shall do the following:

- 1 IF MWN Demand Pip Tone Activation is authorized:
 - 1-1 Optionally, include the *AnnouncementCode* parameter in the *AnnouncementList* parameter set to an appropriate announcement.
 - 1-2 Include the *FeatureResult* parameter set to *Successful* to indicate successful feature operation.
 - 1-3 De-Activate MWN Pip Tone in the subscriber’s service profile.
- 2 ELSE:

- 1
2
3
4
5
6
7
8
9
10
- 2-1 Optionally, include the *AnnouncementCode* parameter in the *AnnouncementList* parameter set to an appropriate announcement.
 - 2-2 Include the *FeatureResult* parameter set to *Unsuccessful* to indicate unsuccessful feature operation.
 - 3 ENDIF.
 - 4 Set *PointOfReturn* to *ToneTermination*.
 - 5 Return to calling task via the *PointOfReturn*.

5.13.3 HLR MWN Pip Tone Temporary De-Activation

13
14 Upon request, the HLR shall do the following:

- 15
16
- 1 IF MWN Demand Pip Tone Activation is authorized:
 - 17 1-1 Include *OneTimeFeatureIndicator* parameter with the *Message Waiting Notification* clear.
 - 18 1-2 Optionally, include the *AnnouncementCode* parameter in the *AnnouncementList* parameter set to an appropriate announcement.
 - 19 1-3 Include the *FeatureResult* parameter set to *Successful* to indicate successful feature operation.
 - 20 1-4 Execute the “Termination Address Expansion” task (see 6.2.1).
 - 2 ELSE:
 - 21 2-1 Optionally, include the *AnnouncementCode* parameter in the *AnnouncementList* parameter set to an appropriate announcement.
 - 22 2-2 Include the *FeatureResult* parameter set to *Unsuccessful* to indicate unsuccessful feature operation.
 - 23 3 ENDIF.
 - 24 3-1 Set *PointOfReturn* to *ToneTermination*.
 - 25 4 Return to calling task via the *PointOfReturn*.
- 26
27
28
29
30
31
32
33
34
35
36

5.13.4 HLR MWN Demand Alert Pip Tone Activation

37
38 Upon request, the HLR shall do the following:

- 39
40
- 41 1 IF MWN Demand Alert Pip Tone Activation is authorized:
 - 42 1-1 Optionally, include the *AnnouncementCode* parameter in the *AnnouncementList* parameter set to an appropriate announcement.
 - 43 1-2 Include the *FeatureResult* parameter set to *Successful* to indicate successful feature operation.
 - 44 1-3 Activate MWN Alert Pip Tone in the subscriber’s service profile.
 - 45 2 ELSE:
 - 46 2-1 Optionally, include the *AnnouncementCode* parameter in the *AnnouncementList* parameter set to an appropriate announcement.
 - 47 2-2 Include the *FeatureResult* parameter set to *Unsuccessful* to indicate unsuccessful feature operation.
 - 48 3 ENDIF.
 - 49 4 Set *PointOfReturn* to *ToneTermination*.
- 50
51
52
53
54
55
56
57
58
59
60

- 5 Return to calling task via the PointOfReturn.

5.13.5 HLR MWN Demand Alert Pip Tone De-Activation

Upon request, the HLR shall do the following:

- 1 IF MWN Demand Alert Pip Tone Activation is authorized:
 - 1-1 Optionally, include the AnnouncementCode parameter in the AnnouncementList parameter set to an appropriate announcement.
 - 1-2 Include the FeatureResult parameter set to *Successful* to indicate successful feature operation.
 - 1-3 De-Activate MWN Alert Pip Tone in the subscriber's service profile.
- 2 ELSE:
 - 2-1 Optionally, include the AnnouncementCode parameter in the AnnouncementList parameter set to an appropriate announcement.
 - 2-2 Include the FeatureResult parameter set to *Unsuccessful* to indicate unsuccessful feature operation.
- 3 ENDIF.
- 4 Set PointOfReturn to *ToneTermination*.
- 5 Return to calling task via the PointOfReturn.

5.13.6 HLR MWN Status Change Invocation

When the HLR detects a change to the MWN status for an MS, it shall perform the following:

- 1 IF the subscriber has MWN Alert Pip Tone, Pip Tone, or MS Indication active:
 - 1-1 IF the MWN count has changed to zero:
 - 1-1-1 Clear the *MWN Pip Tone Notification* indication.
 - 1-1-2 Clear the *MWN Alert Pip Tone Notification* indication.
 - 1-1-3 Clear the *MWN MS Indication* indication.
 - 1-1-4 Execute a "HLR Initiating a Qualification Directive" task (see 4.32.1).
 - 1-2 ELSEIF the MWN count has changed from zero:
 - 1-2-1 IF the subscriber has MWN Pip Tone Active:
 - 1-2-1-1 Set the *MWN Pip Tone Notification* indication.
 - 1-2-2 ENDIF.
 - 1-2-5 IF the subscriber has MWN MS Indication Active:
 - 1-2-5-1 Set the *MWN MS Indication* indication.
 - 1-2-6 ENDIF.
 - 1-2-7 Execute a "HLR Initiating a Qualification Directive" task (see 4.32.1).
 - 1-3 ELSE:
 - 1-3-1 (Ignore the change.)
 - 1-4 ENDIF.
- 2 ELSEIF the subscriber has the MWN MS Count active:
 - 2-1 Execute a "HLR Initiating a Qualification Directive" task (see 4.32.1).

- 3 ELSE:
- 3-1 (Ignore the change.)
- 4 ENDIF.
- 5 Exit this task.

5.13.7 MSC MWN Call Origination Invocation

Upon request, the MSC shall do the following:

- 1 IF the subscriber's MessageWaitingNotification is active in the OneTimeFeatureIndicator parameter and its MessageWaitingNotificationCount is non-zero:
 - 1-1 Provide Pip Tone in-band.
 - 2 ENDIF.
 - 3 Return to calling task.

5.13.8 MSC MWN Call Termination Invocation

Upon request, the MSC shall do the following:

- 1 IF the subscriber's MessageWaitingNotification is active in the OneTimeFeatureIndicator parameter and its MessageWaitingNotificationCount is non-zero:
 - 1-1 Provide Pip Tone in-band.
 - 2 ENDIF.
 - 3 Return to calling task.

5.13.9 MSC MWN Status Change Invocation

Upon request, the MSC shall do the following:

- 1 IF a MessageWaitingNotificationCount or MessageWaitingNotificationType parameter is received:
 - 1-1 IF the MS is served by the current system:
 - 1-1-1 IF the MessageWaitingNotificationCount parameter was received:
 - 1-1-1-1 Order the MS to update its message waiting notification count(s).
 - 1-1-2 ENDIF.
 - 1-1-3 IF the Message Waiting Indication is requested by the MessageWaitingNotificationType parameter:
 - 1-1-3-1 Order the MS to update its message waiting notification indicator.
 - 1-1-4 ENDIF.
 - 1-1-5 IF the Alert Pip Tone is requested by the MessageWaitingNotificationType parameter:
 - 1-1-5-1 IF the indicated MS is *idle*:
 - 1-1-5-2 Order the MS to alert with the alert pip tone.
 - 1-1-5-1 ENDIF.

- 1-1-6 ENDIF. 1
- 1-2 ELSEIF the MS has been handed off to another system: 2
- 1-2-1 IF the MessageWaitingNotificationCount parameter was received: 3
- 1-2-1-1 Relay the received MessageWaitingNotificationCount parameter. 4
- 1-2-2 ENDIF. 5
- 1-2-3 IF the Message Waiting Indication is requested by the 6
- MessageWaitingNotificationType parameter: 7
- 1-2-3-1 Relay the received MessageWaitingNotificationType parameter. 8
- 1-2-4 ENDIF. 9
- 1-2-5 IF a parameter has been relayed: 10
- 1-2-5-1 Execute the “MSC Initiating an Information Forward” task (see 4.23.1). 11
- 1-2-6 ENDIF. 12
- 1-3 ENDIF. 13
- 2 ENDIF. 14
- 3 Return to calling task. 15

5.14 MOBILE ACCESS HUNTING (MAH) 16

5.14.1 HLR MAH Demand Ordering 17

Upon request, the HLR shall do the following: 18

- 1 IF the modifier digit indicates *first*: 19
- 1-1 IF no extra digits were specified (to select the default MAH group): 20
- 1-1-1 IF MAH demand ordering on that group is authorized: 21
- 1-1-1-1 Register the subscriber to the front of the default MAH group list. 22
- 1-1-1-2 Include the FeatureResult parameter set to *Successful* to indicate 23
- successful feature operation. 24
- 1-1-2 ELSE (subscriber is not authorized): 25
- 1-1-2-1 Optionally, include the AnnouncementCode parameter in the 26
- AnnouncementList parameter set to an appropriate announcement. 27
- 1-1-2-2 Include the FeatureResult parameter set to *Unsuccessful* to indicate 28
- unsuccessful feature operation. 29
- 1-1-3 ENDIF. 30
- 1-2 ELSEIF an MAH pilot directory number is specified (to select an MAH group): 31
- 1-2-1 IF the MS is a member of the specified MAH group: 32
- 1-2-1-1 IF MAH demand ordering on that group is authorized: 33
- 1-2-1-1-1 Register the subscriber to the front of the specified MAH group list. 34
- 1-2-1-1-2 Include the FeatureResult parameter set to *Successful* to indicate 35
- successful feature operation. 36
- 1-2-1-2 ELSE (subscriber is not authorized): 37
- 1-2-1-2-1 Optionally, include the AnnouncementCode parameter in the 38
- AnnouncementList parameter set to an appropriate announcement. 39

- 1 1-2-1-2-2 Include the FeatureResult parameter set to *Unsuccessful* to indicate
2 unsuccessful feature operation.
- 3 1-2-1-3 ENDF.
- 4 1-2-2 ELSE (the subscriber is not a member of that group):
- 5 1-2-2-1 Optionally, include the AnnouncementCode parameter in the
6 AnnouncementList parameter set to an appropriate announcement.
- 7 1-2-2-2 Include the FeatureResult parameter set to *Unsuccessful* to indicate
8 unsuccessful feature operation.
- 9 1-2-3 ENDF.
- 10 1-3 ELSE (MAH pilot directory number was not specified):
- 11 1-3-1 Optionally, include the AnnouncementCode parameter in the
12 AnnouncementList parameter set to an appropriate announcement.
- 13 1-3-2 Include the FeatureResult parameter set to *Unsuccessful* to indicate
14 unsuccessful feature operation.
- 15 1-4 ENDF.
- 16 2 ELSEIF the modifier digit indicates *last*:
- 17 2-1 IF no extra digits were specified (to select the default MAH group):
- 18 2-1-1 IF MAH demand ordering on that group is authorized:
- 19 2-1-1-1 Register the subscriber to the end of the default MAH group list.
- 20 2-1-1-2 Include the FeatureResult parameter set to *Successful* to indicate
21 successful feature operation.
- 22 2-1-2 ELSE (subscriber is not authorized):
- 23 2-1-2-1 Optionally, include the AnnouncementCode parameter in the
24 AnnouncementList parameter set to an appropriate announcement.
- 25 2-1-2-2 Include the FeatureResult parameter set to *Unsuccessful* to indicate
26 unsuccessful feature operation.
- 27 2-1-3 ENDF.
- 28 2-2 ELSEIF an MAH pilot directory number is specified:
- 29 2-2-1 IF the MS is a member of the specified MAH group:
- 30 2-2-1-1 IF MAH demand ordering on that group is authorized:
- 31 2-2-1-1-1 Register the subscriber to the end of the specified MAH group list.
- 32 2-2-1-1-2 Include the FeatureResult parameter set to *Successful* to indicate
33 successful feature operation.
- 34 2-2-1-2 ELSE (subscriber is not authorized):
- 35 2-2-1-2-1 Optionally, include the AnnouncementCode parameter in the
36 AnnouncementList parameter set to an appropriate announcement.
- 37 2-2-1-2-2 Include the FeatureResult parameter set to *Unsuccessful* to indicate
38 unsuccessful feature operation.
- 39 2-2-1-3 ENDF.
- 40 2-2-2 ELSE (the subscriber dialed a bad directory number):
- 41 2-2-2-1 Optionally, include the AnnouncementCode parameter in the
42 AnnouncementList parameter set to an appropriate announcement.
- 43 2-2-2-2 Include the FeatureResult parameter set to *Unsuccessful* to indicate
44 unsuccessful feature operation.

- 2-2-3 ENDIF. 1
- 2-3 ELSE (MAH pilot directory number was not specified): 2
- 2-3-1 Optionally, include the AnnouncementCode parameter in the 3
AnnouncementList parameter set to an appropriate announcement. 4
- 2-3-2 Include the FeatureResult parameter set to *Unsuccessful* to indicate 5
unsuccessful feature operation. 6
- 2-4 ENDIF. 7
- 3 ELSE (unknown or no modifier digit): 8
- 3-1 Optionally, include the AnnouncementCode parameter in the AnnouncementList 9
parameter set to an appropriate announcement. 10
- 3-2 Include the FeatureResult parameter set to *Unsuccessful* to indicate unsuccessful 11
feature operation. 12
- 4 ENDIF. 13
- 5 Return to calling task. 14

5.14.2 HLR MAH Membership Activation 15

Upon request, the HLR shall do the following: 16

- 1 IF an MAH pilot directory number is specified: 17
- 1-1 IF the MS is a member of the specified MAH group: 18
- 1-1-1 IF MAH Membership activation on that group is authorized: 19
- 1-1-1-1 Activate the subscriber's membership in the selected MAH group. 20
- 1-1-1-2 Include the FeatureResult parameter set to *Successful* to indicate 21
successful feature operation. 22
- 1-1-2 ELSE (subscriber is not authorized): 23
- 1-1-2-1 Optionally, include the AnnouncementCode parameter in the 24
AnnouncementList parameter set to an appropriate announcement. 25
- 1-1-2-2 Include the FeatureResult parameter set to *Unsuccessful* to indicate 26
unsuccessful feature operation. 27
- 1-1-3 ENDIF. 28
- 1-2 ELSE (subscriber is not a member of the group): 29
- 1-2-1 Optionally, include the AnnouncementCode parameter in the 30
AnnouncementList parameter set to an appropriate announcement. 31
- 1-2-2 Include the FeatureResult parameter set to *Unsuccessful* to indicate 32
unsuccessful feature operation. 33
- 1-3 ENDIF. 34
- 2 ELSEIF no extra digits were specified (to select the default MAH group): 35
- 2-1 IF MAH Membership activation on that group is authorized: 36
- 2-1-1 Optionally, include the AnnouncementCode parameter in the 37
AnnouncementList parameter set to an appropriate announcement. 38
- 2-1-2 Activate the subscriber's membership in the default MAH group. 39
- 2-1-3 Include the FeatureResult parameter set to *Successful* to indicate successful 40
feature operation. 41
- 2-2 ELSE (subscriber is not authorized): 42

- 1 2-2-1 Optionally, include the `AnnouncementCode` parameter in the
2 `AnnouncementList` parameter set to an appropriate announcement.
3
4 2-2-2 Include the `FeatureResult` parameter set to *Unsuccessful* to indicate
5 unsuccessful feature operation.
6
7 2-3 ENDIF.
8
9 3 ELSE (MAH pilot directory number was not specified):
10 3-1 Optionally, include the `AnnouncementCode` parameter in the `AnnouncementList`
11 parameter set to an appropriate announcement.
12 3-2 Include the `FeatureResult` parameter set to *Unsuccessful* to indicate unsuccessful
13 feature operation.
14 4 ENDIF.
15 5 Return to calling task.

5.14.3 HLR MAH Membership De-Activation

20 Upon request, the HLR shall do the following:

- 21 1 IF an MAH pilot directory number is specified:
22 1-1 IF the MS is a member of the specified MAH group:
23 1-1-1 IF MAH Membership de-activation on that group is authorized:
24 1-1-1-1 De-activate the subscriber's membership in the selected MAH group.
25 1-1-1-2 Include the `FeatureResult` parameter set to *Successful* to indicate
26 successful feature operation.
27 1-1-1-2 ELSE (subscriber is not authorized):
28 1-1-2-1 Optionally, include the `AnnouncementCode` parameter in the
29 `AnnouncementList` parameter set to an appropriate announcement.
30 1-1-2-2 Include the `FeatureResult` parameter set to *Unsuccessful* to indicate
31 unsuccessful feature operation.
32 1-1-3 ENDIF.
33 1-2 ELSE (subscriber is not a member of the group):
34 1-2-1 Optionally, include the `AnnouncementCode` parameter in the
35 `AnnouncementList` parameter set to an appropriate announcement.
36 1-2-2 Include the `FeatureResult` parameter set to *Unsuccessful* to indicate
37 unsuccessful feature operation.
38 1-3 ENDIF.
39 2 ELSEIF no extra digits were specified (to select the default MAH group):
40 2-1 IF MAH Membership de-activation on that group is authorized:
41 2-1-1 De-activate the subscriber's membership in the default MAH group.
42 2-1-2 Include the `FeatureResult` parameter set to *Successful* to indicate successful
43 feature operation.
44 3 ELSE (MAH pilot directory number was not specified):
45 3-1 Optionally, include the `AnnouncementCode` parameter in the
46 `AnnouncementList` parameter set to an appropriate announcement.
47 3-1-1 Include the `FeatureResult` parameter set to *Unsuccessful* to indicate
48 unsuccessful feature operation.
49
50
51
52
53
54
55
56
57
58
59
60

- 3-2 ELSE (subscriber is not authorized):
- 3-2-1 Optionally, include the AnnouncementCode parameter in the AnnouncementList parameter set to an appropriate announcement.
- 3-2-2 Include the FeatureResult parameter set to *Unsuccessful* to indicate unsuccessful feature operation.
- 3-3 ENDIF.
- 4 ENDIF.
- 5 Return to calling task.

5.14.4 HLR MAH Incoming Call Invocation

When the HLR determines the needs for MAH incoming call routing, it shall perform the following tasks:

- 1 Optionally, store the BillingID parameter and correlate it to the other stored information about this call.
- 2 Set the access denied reason to the lowest priority reason.
- 3 (Execute Incoming Call Feature Processes applicable to the MAH Group as a whole:)
- 4 Include the OneTimeFeatureIndicator parameter set for the features of the MAH Group.
- 5 Include the TerminationTriggers parameter set for the features of the MAH Group.
- 6 FOR all active members of the MAH Group (optionally excluding a member originating the call):
 - 6-1 IF the member is an MS on the current HLR:
 - 6-1-1 IF the MS is registered to the requesting system:
 - 6-1-1-1 IF the MS is active:
 - 6-1-1-1-1 Include the ElectronicSerialNumber parameter set to identify the called MS within a LocalTermination parameter within a TerminationList parameter.
 - 6-1-1-1-2 Include the MobileIdentificationNumber parameter set to identify the called MS within a LocalTermination parameter within a TerminationList parameter.
 - 6-1-1-1-3 Include the TerminationTreatment parameter set to within a LocalTermination parameter within a TerminationList parameter.
 - 6-1-1-1-4 IF custom alerting is applicable for the call:
 - 6-1-1-1-4-1 Include the AlertCode parameter within a LocalTermination parameter within a TerminationList parameter set appropriately.
 - 6-1-1-1-5 ENDIF.
 - 6-1-1-1-6 IF triggers should be set for this terminating leg at the originating switch for the redirecting call:
 - 6-1-1-1-6-1 Include the TerminationTriggers parameter.
 - 6-1-1-1-7 ENDIF.
 - 6-1-1-1-8 Set the PointOfReturn to *LocalTermination*.
 - 6-1-1-1-9 Return to calling task via the PointOfReturn.
 - 6-1-1-2 ELSE (the MS cannot be accessed):

1 6-1-1-2-1 IF *Inactive* is a higher priority reason than the current access denied
2 reason:
3
4 6-1-1-2-1-1 Set the access denied reason to *Inactive*.
5 6-1-1-2-2 ENDIF.
6 6-1-1-3 ENDIF.
7
8 6-1-2 ELSE (the member is an MS registered on another system):
9 6-1-2-1 IF the MS is active:
10 6-1-2-1-1 Include the TerminationTreatment parameter set to *MS Termination*.
11 6-1-2-1-2 Include the OneTimeFeatureIndicator parameter set appropriately.
12 6-1-2-1-3 IF custom alerting is applicable for the call:
13 6-1-2-1-3-1 Include the AlertCode parameter set appropriately.
14 6-1-2-1-4 ENDIF.
15 6-1-2-1-5 IF triggers should be set for the terminating party at the terminating
16 switch for this call:
17 6-1-2-1-5-1 Include the TerminationTriggers parameter.
18 6-1-2-1-6 ENDIF.
19 6-1-2-1-7 Execute the "HLR Initiating a Routing Request" task (see 4.41.1).
20 6-1-2-1-8 Set the denied reason to *Allowed*.
21 6-1-2-1-9 IF the AccessDeniedReason parameter is received and it can be acted
22 upon:
23 6-1-2-1-9-1 Set the denied reason to the received AccessDeniedReason
24 value:
25 6-1-2-1-10 ENDIF.
26 6-1-2-1-11 IF the ConditionallyDeniedReason parameter is received and it can
27 be acted upon:
28 6-1-2-1-11-1 IF the ConditionallyDeniedReason is *Waitable* :
29 6-1-2-1-11-1-1 IF Call Waiting is desirable on the first attempt:
30 6-1-2-1-11-1-1-1 Set the denied reason to *Allowed*.
31 6-1-2-1-11-1-2 ELSE:
32 6-1-2-1-11-1-2-1 Optionally remember the waitable member for a second
33 attempt.
34 6-1-2-1-11-1-2-2 Set the denied reason to *Busy*.
35 6-1-2-1-11-1-3 ENDIF.
36 6-1-2-1-11-2 ENDIF.
37 6-1-2-1-12 ENDIF.
38 6-1-2-1-13 IF denied reason value is *Allowed*:
39 6-1-2-1-13-1 IF Digits (Destination) parameter is received:
40 6-1-2-1-13-1-1 Include the Digits (Destination) parameter in the
41 IntersystemTermination parameter within the
42 TerminationList parameter set to the received
43 Digits(Destination) parameter.
44 6-1-2-1-13-1-2 Relay other relevant received parameters within the
45 IntersystemTermination parameter within the
46 TerminationList parameter.
47
48
49
50
51
52
53
54
55
56
57
58
59
60

| | | |
|----------------|--|----|
| 6-1-2-1-13-1-3 | Set the PointOfReturn to <i>IntersystemTermination</i> . | 1 |
| 6-1-2-1-13-1-4 | Return to calling task via the PointOfReturn. | 2 |
| 6-1-2-1-13-2 | ELSE (no Digits (Destination) parameter is received with the AccessDeniedReason): | 3 |
| 6-1-2-1-13-2-1 | (Pass on this member, can't route to it and can't look at its status.) | 4 |
| 6-1-2-1-13-3 | ENDIF. | 5 |
| 6-1-2-1-14 | ELSEIF the denied reason parameter indicates <i>Busy</i> . | 6 |
| 6-1-2-1-14-1 | IF the MAH group is a Single User Group. | 7 |
| 6-1-2-1-14-1-1 | Discard the AnnouncementList and TerminationList parameters. | 8 |
| 6-1-2-1-14-1-2 | Discard the parameters stored with the BillingID parameter. | 9 |
| 6-1-2-1-14-1-3 | Relay the AccessDeniedReason parameter. | 10 |
| 6-1-2-1-14-1-4 | Set the PointOfReturn to <i>ToneTermination</i> . | 11 |
| 6-1-2-1-14-1-5 | Return to calling task via the PointOfReturn. | 12 |
| 6-1-2-1-14-2 | ELSE (the MAH group is a Multiple User Group): | 13 |
| 6-1-2-1-14-2-1 | (Skip this member.) | 14 |
| 6-1-2-1-14-3 | ENDIF. | 15 |
| 6-1-2-1-15 | ELSE (access is denied): | 16 |
| 6-1-2-1-15-1 | IF the AccessDeniedReason is a higher priority reason than the current access denied reason: | 17 |
| 6-1-2-1-15-1-1 | Set the access denied reason to received AccessDeniedReason parameter. | 18 |
| 6-1-2-1-15-2 | ENDIF. | 19 |
| 6-1-2-1-16 | ENDIF. | 20 |
| 6-1-2-2 | ELSE (The MS is not active): | 21 |
| 6-1-2-2-1 | IF <i>Inactive</i> is a higher priority reason than the current access denied reason: | 22 |
| 6-1-2-2-1-1 | Set the access denied reason to <i>Inactive</i> . | 23 |
| 6-1-2-2-2 | ENDIF. | 24 |
| 6-1-2-3 | ENDIF. | 25 |
| 6-1-3 | ENDIF. | 26 |
| 6-2 | ELSE (member is not homed to this HLR, treat it as a PSTN termination): | 27 |
| 6-2-1 | IF this leg requires special termination trigger treatment: | 28 |
| 6-2-1-1 | Include the TerminationTriggers parameter setting desired triggers for this leg. | 29 |
| 6-2-2 | ENDIF. | 30 |
| 6-2-3 | Include the relevant parameters in a PSTNTermination parameter in the TerminationList parameter. | 31 |
| 6-2-4 | Set the PointOfReturn to <i>PSTNTermination</i> . | 32 |
| 6-3 | ENDIF. | 33 |
| 7 | ENDFOR. | 34 |
| 8 | (Completed a first attempt to all members of the MAH group.) | 35 |

- 9 IF there is a waitable member.
 9-1 Optionally attempt to terminate to the waitable member.
 10 ENDIF.
 11 Return to calling task via the PointOfReturn.

5.14.5 HLR MAH Revertive Call Invocation

Upon request, the HLR shall perform the following tasks:

- 1 Execute "HLR MAH Incoming Call Invocation" task (see 5.14.4).
- 2 Return to calling task.

5.14.6 HLR MAH Busy MS Invocation

When the HLR detects a busy MS¹, it shall perform the following tasks:

- 1 IF the HLR maintains context information for an MAH call:
 - 1-1 IF the BillingID parameter from the request matches a current MAH call:
 - 1-1-1 IF the MAH group is a Single User Group:
 - 1-1-1-1 IF the group features apply based on the context of the transaction:
 - 1-1-1-1-1 Execute service specific logic applicable to the group as a whole. The interaction between MAH and other features is beyond the scope of this Standard.
 - 1-1-1-1-2 IF the request came from the Originating MSC:
 - 1-1-1-1-2-1 Include the ActionCode parameter set appropriately (e.g., *Disconnect all call legs*).
 - 1-1-1-1-3 ENDIF.
 - 1-1-1-1-4 Include the AccessDeniedReason parameter appropriately (e.g., *Busy*).
 - 1-1-1-2 ELSE (individual feature operation):
 - 1-1-1-2-1 Execute service specific logic applicable to the individual subscriber. The interaction between MAH and other features is beyond the scope of this Standard.
 - 1-1-1-2-2 Include the ActionCode parameter set appropriately (e.g., *Disconnect call leg*).
 - 1-1-1-3 ENDIF.
 - 1-1-2 ELSE (the MAH group is a Multiple User Group):
 - 1-1-2-1 IF the group features apply based on the context of the transaction:
 - 1-1-2-1-1 Execute service specific logic applicable to the group as a whole. The interaction between MAH and other features is beyond the scope of this Standard.
 - 1-1-2-1-2 IF the request came from the Originating MSC:

¹This task is used for multiple detecte conditions, so the treatment should be changes appropriately.

| | | |
|-------------|--|----------------------------|
| 1-1-2-1-2-1 | Include the <code>ActionCode</code> parameter set appropriately (e.g., <i>Disconnect all call legs</i>). | 1
2 |
| 1-1-2-1-3 | ENDIF. | 3
4 |
| 1-1-2-1-4 | Include the <code>AccessDeniedReason</code> parameter set appropriately (e.g., <i>Busy</i>). | 5
6 |
| 1-1-2-2 | ELSE (individual feature operation): | 7
8 |
| 1-1-2-2-1 | Execute service specific logic applicable to the individual subscriber. The interaction between MAH and other features is beyond the scope of this Standard. | 9
10
11 |
| 1-1-2-2-2 | Include the <code>ActionCode</code> parameter set appropriately (e.g., <i>Disconnect call leg</i>). | 12
13 |
| 1-1-2-3 | ENDIF. | 14
15 |
| 1-1-3 | ENDIF. | 16
17 |
| 1-2 | ELSE (invalid or unknown <code>BillingID</code> parameter): | 18 |
| 1-2-1 | Continue processing the call. | 19 |
| 1-3 | ENDIF. | 20
21 |
| 2 | ELSE (the HLR does not use context information for an MAH call): | 22 |
| 2-1 | IF the MAH pilot directory number can be determined from a received <code>PilotNumber</code> parameter. | 23
24 |
| 2-1-1 | IF the MAH group is a Single User Group: | 25
26 |
| 2-1-1-1 | IF the <code>GroupInformation</code> parameter is received: | 27 |
| 2-1-1-1-1 | Execute service specific logic applicable to the MAH Group as a whole. The interaction between MAH and other features is beyond the scope of this Standard. | 28
29
30
31 |
| 2-1-1-2 | ELSEIF the <code>LegInformation</code> parameter is received: | 32 |
| 2-1-1-2-1 | Execute service specific logic applicable to the individual subscriber. The interaction between MAH and other features is beyond the scope of this Standard. | 33
34
35
36 |
| 2-1-1-3 | ENDIF. | 37 |
| 2-1-1-4 | IF the request came from the Originating MSC: | 38 |
| 2-1-1-4-1 | Include the <code>ActionCode</code> parameter set appropriately (e.g., <i>Disconnect all call legs</i>). | 39
40
41 |
| 2-1-1-5 | ENDIF. | 42 |
| 2-1-1-6 | Include the <code>AccessDeniedReason</code> parameter set appropriately (e.g., <i>Busy</i>). | 43
44
45 |
| 2-1-2 | ELSE (the MAH group is a Multiple User Group): | 46 |
| 2-1-2-1 | IF the <code>GroupInformation</code> parameter is received: | 47 |
| 2-1-2-1-1 | Execute service specific logic applicable to the group as a whole. The interaction between MAH and other features is beyond the scope of this Standard. | 48
49
50
51 |
| 2-1-2-1-2 | IF the request came from the Originating MSC: | 52 |
| 2-1-2-1-2-1 | Include the <code>ActionCode</code> parameter set appropriately (e.g., <i>Disconnect all call legs</i>). | 53
54
55 |
| 2-1-2-1-3 | ENDIF. | 56
57
58
59
60 |

- 1 2-1-2-1-4 Include the AccessDeniedReason parameter set appropriately (e.g.,
2 *Busy*).
3
4 2-1-2-2 ELSEIF the LegInformation parameter is received:
5 2-1-2-2-1 Execute service specific logic applicable to the individual subscriber.
6 The interaction between MAH and other features is beyond the scope
7 of this Standard.
8
9 2-1-2-3 ENDIF.
10 2-1-3 ENDIF.
11 2-2 ELSE (PilotNumber does not indicate an MAH pilot directory number):
12 2-2-1 Continue processing the call.
13 2-3 ENDIF.
14 3 ENDIF.
15 4 Return to the calling task.
16
17
18
19

5.14.7 HLR MAH Inactive MS Invocation

21 When the HLR detects an inactive MS, it shall perform the following tasks:

- 22 1 Execute the “HLR MAH Busy MS Invocation” task (see 5.14.6).
- 23 2 Return to the calling task.

5.14.8 HLR MAH Unavailable MS Invocation

27 When the HLR detects an unavailable MS, it shall perform the following tasks:

- 28 1 Execute the “HLR MAH Busy MS Invocation” task (see 5.14.6).
- 29 2 Return to the calling task.

5.14.9 HLR MAH Unresponsive MS Invocation

35 When the HLR detects an MS that does not respond to paging, it shall perform the
36 following tasks:

- 37 1 Execute the “HLR MAH Busy MS Invocation” task (see 5.14.6).
- 38 2 Return to the calling task.

5.14.10 HLR MAH No Answer MS Invocation

44 When the HLR detects an MS that does not answer, it shall perform the following tasks:

- 45 1 Execute the “HLR MAH Busy MS Invocation” task (see 5.14.6).
- 46 2 Return to the calling task.

5.14.11 HLR MAH Unroutable MS Invocation

52 When the HLR detects an unavailable MS, it shall perform the following tasks:

- 53 1 Execute the “HLR MAH Busy MS Invocation” task (see 5.14.6).

- 2 Return to the calling task.

5.15 PASSWORD CALL ACCEPTANCE (PCA)

5.15.1 HLR PCA Diversion Number Registration

Upon request, the HLR shall do the following:

- 1 IF PCA Demand Diversion Number Registration is authorized:
 - 1-1 IF the termination address is acceptable:
 - 1-1-1 Execute the “HLR SPINI Feature Request Invocation” task (see 5.21.4).
 - 1-1-2 IF the SPINI invocation *failed*:
 - 1-1-2-1 Include the FeatureResult parameter set to *Unsuccessful* to indicate unsuccessful feature operation.
 - 1-1-2-2 Return to the calling task via the PointOfReturn.
 - 1-1-3 ENDIF.
 - 1-1-4 Register the termination address as the PCA diversion number.
 - 1-1-5 Optionally, include the AnnouncementCode parameter in the AnnouncementList parameter set to an appropriate announcement.
 - 1-1-6 Include the FeatureResult parameter set to *Successful* to indicate successful feature operation.
 - 1-1-7 IF activation is to occur with registration:
 - 1-1-7-1 Activate PCA.
 - 1-1-8 ENDIF.
 - 1-2 ELSE:
 - 1-2-1 Optionally, include the AnnouncementCode parameter in the AnnouncementList parameter set to an appropriate announcement.
 - 1-2-2 Include the FeatureResult parameter set to *Unsuccessful* to indicate unsuccessful feature operation.
 - 1-3 ENDIF.
- 2 ELSE:
 - 2-1 Optionally, include the AnnouncementCode parameter in the AnnouncementList parameter set to an appropriate announcement.
 - 2-2 Include the FeatureResult parameter set to *Unsuccessful* to indicate unsuccessful feature operation.
- 3 ENDIF.
- 4 Set PointOfReturn to *ToneTermination*.
- 5 Return to calling task via the PointOfReturn.

5.15.2 HLR PCA Diversion Number De-Registration

Upon request, the HLR shall do the following:

- 1 IF PCA Demand Diversion Number Registration is authorized:
 - 1-1 De-Register the PCA diversion number.

- 1
2
3
4
5
6
7
8
9
10
11
12
13
14
15
16
17
18
- 1-2 Optionally, include the `AnnouncementCode` parameter in the `AnnouncementList` parameter set to an appropriate announcement.
 - 1-3 Include the `FeatureResult` parameter set to *Successful* to indicate successful feature operation.
 - 1-4 De-Activate PCA.
 - 2 ELSE:
 - 2-1 Optionally, include the `AnnouncementCode` parameter in the `AnnouncementList` parameter set to an appropriate announcement.
 - 2-2 Include the `FeatureResult` parameter set to *Unsuccessful* to indicate unsuccessful feature operation.
 - 3 ENDIF.
 - 4 Set `PointOfReturn` to *ToneTermination*.
 - 5 Return to calling task via the `PointOfReturn`.

5.15.3 HLR PCA Password Registration

21 Upon request, the HLR shall do the following:

- 22
- 1 IF PCA Demand Password Registration is authorized:
 - 1-1 IF the password is acceptable:
 - 1-1-1 Register the password for PCA.
 - 1-1-2 Optionally, include the `AnnouncementCode` parameter in the `AnnouncementList` parameter set to an appropriate announcement.
 - 1-1-3 Include the `FeatureResult` parameter set to *Successful* to indicate successful feature operation.
 - 1-1-4 IF activation is to occur with registration:
 - 1-1-4-1 Activate PCA.
 - 1-1-5 ENDIF.
 - 1-2 ELSE:
 - 1-2-1 Optionally, include the `AnnouncementCode` parameter in the `AnnouncementList` parameter set to an appropriate announcement.
 - 1-2-2 Include the `FeatureResult` parameter set to *Unsuccessful* to indicate unsuccessful feature operation.
 - 1-3 ENDIF.
 - 2 ELSE:
 - 2-1 Optionally, include the `AnnouncementCode` parameter in the `AnnouncementList` parameter set to an appropriate announcement.
 - 2-2 Include the `FeatureResult` parameter set to *Unsuccessful* to indicate unsuccessful feature operation.
 - 3 ENDIF.
 - 4 Set `PointOfReturn` to *ToneTermination*.
 - 5 Return to calling task via the `PointOfReturn`.
- 55
56
57
58
59
60

5.15.4 HLR PCA Password De-Registration

Upon request, the HLR shall do the following:

- 1 IF PCA Password Diversion Number Registration is authorized:
 - 1-1 IF a specific password was specified:
 - 1-1-1 De-Register the specified PCA password.
 - 1-1-2 IF no more passwords are registered:
 - 1-1-2-1 De-Activate PCA.
 - 1-1-3 ENDIF.
 - 1-1-4 Optionally, include the `AnnouncementCode` parameter in the `AnnouncementList` parameter set to an appropriate announcement.
 - 1-1-5 Include the `FeatureResult` parameter set to *Successful* to indicate successful feature operation.
 - 1-2 ELSEIF the bulk de-registration modifier digits were specified:
 - 1-2-1 De-Register all PCA passwords.
 - 1-2-2 De-Activate PCA.
 - 1-2-3 Optionally, include the `AnnouncementCode` parameter in the `AnnouncementList` parameter set to an appropriate announcement.
 - 1-2-4 Include the `FeatureResult` parameter set to *Successful* to indicate successful feature operation.
 - 1-3 ELSE:
 - 1-3-1 Optionally, include the `AnnouncementCode` parameter in the `AnnouncementList` parameter set to an appropriate announcement.
 - 1-3-2 Include the `FeatureResult` parameter set to *Unsuccessful* to indicate unsuccessful feature operation.
 - 1-4 ENDIF.
- 2 ELSE:
 - 2-1 Optionally, include the `AnnouncementCode` parameter in the `AnnouncementList` parameter set to an appropriate announcement.
 - 2-2 Include the `FeatureResult` parameter set to *Unsuccessful* to indicate unsuccessful feature operation.
- 3 ENDIF.
- 4 Set `PointOfReturn` to *ToneTermination*.
- 5 Return to calling task via the `PointOfReturn`.

5.15.5 HLR PCA Activation

Upon request, the HLR shall do the following:

- 1 IF a PCA Demand Activation is authorized:
 - 1-1 IF a PCA password is registered:
 - 1-1-1 Activate PCA.
 - 1-1-2 Optionally, include the `AnnouncementCode` parameter in the `AnnouncementList` parameter set to an appropriate announcement.

- 1-1-3 Include the FeatureResult parameter set to *Successful* to indicate successful feature operation.
- 1-2 ELSE:
- 1-2-1 Optionally, include the AnnouncementCode parameter in the AnnouncementList parameter set to an appropriate announcement.
- 1-2-2 Include the FeatureResult parameter set to *Unsuccessful* to indicate unsuccessful feature operation.
- 1-3 ENDIF.
- 2 ELSE:
- 2-1 Optionally, include the AnnouncementCode parameter in the AnnouncementList parameter set to an appropriate announcement.
- 2-2 Include the FeatureResult parameter set to *Unsuccessful* to indicate unsuccessful feature operation.
- 3 ENDIF.
- 4 Set PointOfReturn to *ToneTermination*.
- 5 Return to calling task via the PointOfReturn.

5.15.6 HLR PCA De-Activation

Upon request, the HLR shall do the following:

- 1 IF a PCA Demand Activation is authorized:
- 1-1 De-Activate PCA.
- 1-2 Optionally, include the AnnouncementCode parameter in the AnnouncementList parameter set to an appropriate announcement.
- 1-3 Include the FeatureResult parameter set to *Successful* to indicate successful feature operation.
- 2 ELSE:
- 2-1 Optionally, include the AnnouncementCode parameter in the AnnouncementList parameter set to an appropriate announcement.
- 2-2 Include the FeatureResult parameter set to *Unsuccessful* to indicate unsuccessful feature operation.
- 3 ENDIF.
- 4 Set PointOfReturn to *ToneTermination*.
- 5 Return to calling task via the PointOfReturn.

5.15.7 HLR PCA Incoming Call Invocation

Upon request, the HLR shall do the following:

- 1 IF PCA is active:
- 1-1 IF the TransactionCapability parameter received in the FeatureRequest INVOKE indicates *RemoteUserInteraction* capable:
- 1-1-1 Include the AnnouncementCode parameter in the AnnouncementList parameter set to prompt the calling party to enter a password.
- 1-1-2 Include the DigitCollectionControl parameter set appropriately.

- 1-1-3 Execute a “HLR Initiating a Remote User Interaction Directive” task (see 4.39.1). 1
2
- 1-1-4 IF the received parameter matches a registered password: 3
- 1-1-4-1 Set PointOfReturn to *Accepted*. 4
5
- 1-1-5 ELSEIF the call was abandoned (no Digits (Dialed) parameter was received): 6
- 1-1-5-1 Set PointOfReturn to *ToneTermination*. 7
8
- 1-1-6 ELSE (the call it refused, i.e., the incorrect password was entered or the Digits (Dialed)parameter contains no digits): 9
10
11
12
13
14
- 1-1-6-1 IF the MS has a PCA diversion number active: 15
- 1-1-6-1-1 Execute the “HLR Select Forward-To or Diversion Number Point of Return” task (see 6.1.2). 16
- 1-1-6-1-2 Include the DMH_RedirectionIndicator parameter set to *PCA call refused*. 17
18
- 1-1-6-2 ELSE (use the system default refusal treatment): 19
- 1-1-6-2-1 Optionally, include the AnnouncementCode parameter in the AnnouncementList parameter set to an appropriate announcement. 20
21
22
- 1-1-6-2-2 Include the AccessDeniedReason parameter indicating *Termination Denied*. 23
24
- 1-1-6-2-3 Set PointOfReturn to *ToneTermination*. 25
26
- 1-1-6-3 ENDIF. 27
- 1-1-7 ENDIF. 28
- 1-2 ELSE (transaction is not *RemoteUserInteraction* capable): 29
- 1-2-1 Optionally, include the AnnouncementCode parameter in the AnnouncementList parameter set to an appropriate announcement. 30
31
32
33
- 1-2-2 Set PointOfReturn to *ToneTermination*. 34
- 1-3 ENDIF. 35
- 2 ELSE: 36
- 2-1 Allow the call to continue. 37
38
- 3 ENDIF. 39
- 4 Return to calling task via the PointOfReturn. 40
41
42
43
44

5.16 PREFERRED LANGUAGE (PL) 45

A subscriber’s preferred language is an indicator in the subscriber’s service profile. The preferred language should be honored when playing announcements to a subscriber, routing calls to operator, information, or directory services and when sending network generated short messages. 46
47
48
49
50
51

5.16.1 HLR PL Language Registration 52

Upon request, the HLR shall do the following: 53
54

- 1 IF PL Variable Registration is authorized: 55
56
57
58
59
60

- 1-1 IF the language is acceptable:
- 1-1-1 Register the preferred language.
 - 1-1-2 Optionally, include the `AnnouncementCode` parameter in the `AnnouncementList` parameter set to an appropriate announcement.
 - 1-1-3 Include the `FeatureResult` parameter set to *Successful* to indicate successful feature operation.
- 1-2 ELSE:
- 1-2-1 Optionally, include the `AnnouncementCode` parameter in the `AnnouncementList` parameter set to an appropriate announcement.
 - 1-2-2 Include the `FeatureResult` parameter set to *Unsuccessful* to indicate unsuccessful feature operation.
- 1-3 ENDIF.
- 2 ELSE:
- 2-1 Optionally, include the `AnnouncementCode` parameter in the `AnnouncementList` parameter set to an appropriate announcement.
 - 2-2 Include the `FeatureResult` parameter set to *Unsuccessful* to indicate unsuccessful feature operation.
- 3 ENDIF.
- 4 Set `PointOfReturn` to *ToneTermination*.
 - 5 Return to calling task via the `PointOfReturn`.

5.17 PRIORITY ACCESS AND CHANNEL ASSIGNMENT (PACA)

5.17.1 HLR PACA Per Call Invocation

- 1 IF PACA is authorized:
- 1-1 Relay the `OneTimeFeatureIndicator` parameter with with *Priority Access and Channel Assignment (PACA)* activated.
 - 1-2 Include the `PACAIndicator` parameter set to the currently authorized Priority Level and the subscriber's permanent activation status.
 - 1-3 Include the `FeatureResult` parameter set to *Successful* to indicate successful feature operation.
 - 1-4 Execute the "Termination Address Expansion" task (see 6.2.1).
- 2 ELSE:
- 2-1 Relay the `OneTimeFeatureIndicator` parameter unchanged.
 - 2-2 Include the `FeatureResult` parameter set to *Unsuccessful* to indicate unsuccessful feature operation.
- 3 ENDIF.
- 4 Set `PointOfReturn` to *ToneTermination*.
 - 5 Return to calling task via the `PointOfReturn`.

5.17.2 MSC PACA Call Origination Invocation

Upon determining that an idle voice or traffic channel is not available for an origination and that PACA may apply, the Serving MSC shall perform the following:

- 1 IF a voice or traffic channel has been seized:
 - 1-1 Return to calling task indicating *success*.
- 2 ELSEIF a voice or traffic channel is available:
 - 2-1 Return to calling task indicating *success*.
- 3 ELSEIF the *Priority Access and Channel Assignment (PACA)* of the *OneTimeFeatureIndicator* parameter is active OR IF the *Permanent Activation (PA)* of the *PACAIndicator* parameter is active OR IF PACA is invoked by the dialed number (e.g., 9-1-1, *-9-1-1):
 - 3-1 Determine the PACA priority level appropriate for this service request based upon the subscriber's PACA Level profile information, the received *PACAIndicator* parameter *PACA Level* (valid for this call only) and the identified dialed number (and its associated PACA Level).
 - 3-2 Enter this service request into the bottom of the PACA queue of the determined priority level (if required appropriately displace a lower level queued service request entry).
 - 3-3 Provide feedback to the MS that it is waiting for a channel to become available.
 - 3-4 Start a PACA Feedback Timer (PFT).
 - 3-5 Start a PACA Detection Timer (PDT).
 - 3-6 WAIT for a voice or traffic channel to becomes available:
 - 3-7 WHEN a voice or traffic channel becomes available for this MS:
 - 3-7-1 Stop the timer (PDT).
 - 3-7-2 Stop the timer (PFT).
 - 3-7-3 Remove this request from the PACA queue.
 - 3-7-4 Apply recall distinctive alerting to provide feedback to the MS that its PACA origination request has been honored.
 - 3-7-5 Start a PACA answer timer (PAT).
 - 3-7-6 WAIT for the PACA call to be answered.
 - 3-7-7 WHEN the PACA call is answered:
 - 3-7-7-1 Stop the timer (PAT).
 - 3-7-7-2 Identify the voice or traffic channel selected via PACA.
 - 3-7-7-3 Return to calling task indicating *success*.
 - 3-7-8 WHEN the subscriber abandons the request with the END key or radio contact is lost:
 - 3-7-8-1 Stop the timer (PAT).
 - 3-7-8-2 Return to calling task indicating *failure*.
 - 3-7-9 WHEN the PACA timer (PAT) expires:
 - 3-7-9-1 Return to calling task indicating *failure*.
 - 3-7-10 ENDWAIT.
 - 3-7-11 IF unsuccessful:
 - 3-7-11-1 Return to calling task indicating *failure*.

1
2
3
4
5
6
7
8
9
10
11
12
13
14
15
16
17
18
19
20
21
22
23
24
25
26
27
28
29
30
31
32
33
34
35
36
37
38
39
40
41
42
43
44
45
46
47
48
49
50
51
52
53
54
55
56
57
58
59
60

3-8 WHEN the MS disconnects:

3-8-1 Stop the timer (PDT).

3-8-2 Stop the timer (PFT).

3-8-3 Provide feedback to the MS of its request has been dropped.

3-8-4 Return to calling task indicating *failure*.

3-9 WHEN the MS's presence is detected in the same location:

3-9-1 Stop the timer (PDT).

3-9-2 Start the timer (PDT).

3-9-3 Remain in this state.

3-10 WHEN the MS's presence is detected in a new location within the domain of the MSC:

3-10-1 Stop the timer (PDT).

3-10-2 Start the timer (PDT).

3-10-3 Update the location of the MS.

3-10-4 Remain in this state.

3-11 WHEN this service request was displaced from the PACA queue:

3-11-1 Stop the timer (PDT).

3-11-2 Stop the timer (PFT).

3-11-3 Provide feedback to the MS of its request has been preempted.

3-11-4 Return to calling task indicating *failure*.

3-12 WHEN the timer (PDT) expires (the MS must have moved away or powered down):

3-12-1 Remove this request from the PACA queue.

3-12-2 Stop the timer (PFT).

3-12-3 Return to calling task indicating *failure*.

3-13 WHEN the timer PFT expires:

3-13-1 Start the timer (PFT).

3-13-2 Provide feedback to the MS of its position in the queue and that it is still waiting for a channel to become available.

3-13-3 Remain in this state.

3-14 ENDWAIT.

4 ELSE (the PACA feature is not active):

4-1 Return to calling task indicating *failure*.

5 ENDIF.

5.18 REMOTE FEATURE CONTROL (RFC)

5.18.1 HLR RFC Incoming Call Invocation

Upon request, the HLR shall do the following (a simple version is shown here that is not very user friendly):

1 IF the TransactionCapability parameter received in the FeatureRequest INVOKE indicates *RemoteUserInteraction* capable:

1-1 Include the AnnouncementCode parameter in the AnnouncementList parameter set to prompt the calling party to enter a directory number.

1-2 Include the DigitCollectionControl parameter set appropriately.

1-3 Execute a “HLR Initiating a Remote User Interaction Directive” task (see 4.39.1).

1-4 IF the received Digits (Dialed) parameter matches a support directory number:

1-4-1 Include the AnnouncementCode parameter in the AnnouncementList parameter set to prompt the calling party to enter a PIN.

1-4-2 Include the DigitCollectionControl parameter set appropriately.

1-4-3 Execute a “HLR Initiating a Remote User Interaction Directive” task (see 4.39.1).

1-4-4 IF the received Digits (Dialed) parameter matches the PIN for the directory number:

E

1-4-4-1 Include the AnnouncementCode parameter in the AnnouncementList parameter set to prompt the calling party to enter a feature code.

1-4-4-2 Include the DigitCollectionControl parameter set appropriately.

1-4-4-3 Execute a “HLR Initiating a Remote User Interaction Directive” task (see 4.39.1).

1-4-4-4 IF the Digits (Dialed) parameter is received and the Digits (Dialed) parameter was not empty:

1-4-4-4-1 WHILE digits remain in the Digits (Dialed) parameter:

1-4-4-4-1-1 Set the digits to analyze to digits from the dialed string up to the end of the string or up to and not including a non-introductory star (*) or pound (#) digit.

1-4-4-4-1-2 Set subsequent digits from the remaining string.

1-4-4-4-1-3 IF the subsequent digits begin with a pound (#) digit:

1-4-4-4-1-3-1 Discard the pound (#) digit.

1-4-4-4-1-4 ENDIF.

1-4-4-4-1-5 CASE feature operation based on the dialed feature code OF:

1-4-4-4-1-6 FC: Execute the “HLR CD Activation” task (see 5.1.1).

1-4-4-4-1-7 IF the PointOfReturn is indicated:

1-4-4-4-1-7-1 GOTO RFCPointOfReturn.

1-4-4-4-1-8 ENDIF.

1-4-4-4-1-9 FC: Execute the “HLR CD De-Activation” task (see 5.1.2).

| | | |
|----|----------------|---|
| 1 | 1-4-4-4-1-10 | IF the PointOfReturn is indicated: |
| 2 | | GOTO RFCPointOfReturn. |
| 3 | 1-4-4-4-1-10-1 | ENDIF. |
| 4 | 1-4-4-4-1-11 | <i>FC:</i> Execute the “HLR CFB Activation” task (see 5.2.3). |
| 5 | 1-4-4-4-1-12 | IF the PointOfReturn is indicated: |
| 6 | | GOTO RFCPointOfReturn. |
| 7 | 1-4-4-4-1-13 | ENDIF. |
| 8 | 1-4-4-4-1-13-1 | <i>FC:</i> Execute the “HLR CFB De-Activation” task (see 5.2.4). |
| 9 | 1-4-4-4-1-14 | IF the PointOfReturn is indicated: |
| 10 | | GOTO RFCPointOfReturn. |
| 11 | 1-4-4-4-1-15 | ENDIF. |
| 12 | 1-4-4-4-1-16 | <i>FC:</i> Execute the “HLR CFD Activation” task (see 5.3.3). |
| 13 | 1-4-4-4-1-16-1 | IF the PointOfReturn is indicated: |
| 14 | | GOTO RFCPointOfReturn. |
| 15 | 1-4-4-4-1-17 | ENDIF. |
| 16 | 1-4-4-4-1-18 | <i>FC:</i> Execute the “HLR CFD De-Activation” task (see 5.3.4). |
| 17 | 1-4-4-4-1-19 | IF the PointOfReturn is indicated: |
| 18 | | GOTO RFCPointOfReturn. |
| 19 | 1-4-4-4-1-19-1 | ENDIF. |
| 20 | 1-4-4-4-1-20 | <i>FC:</i> Execute the “HLR CFNA Activation” task (see 5.4.3). |
| 21 | 1-4-4-4-1-21 | IF the PointOfReturn is indicated: |
| 22 | | GOTO RFCPointOfReturn. |
| 23 | 1-4-4-4-1-22 | ENDIF. |
| 24 | 1-4-4-4-1-22-1 | <i>FC:</i> Execute the “HLR CFNA De-Activation” task (see 5.4.4). |
| 25 | 1-4-4-4-1-23 | IF the PointOfReturn is indicated: |
| 26 | | GOTO RFCPointOfReturn. |
| 27 | 1-4-4-4-1-24 | ENDIF. |
| 28 | 1-4-4-4-1-24 | <i>FC:</i> Execute the “HLR CFNA Activation” task (see 5.4.3). |
| 29 | 1-4-4-4-1-25 | IF the PointOfReturn is indicated: |
| 30 | | GOTO RFCPointOfReturn. |
| 31 | 1-4-4-4-1-25-1 | ENDIF. |
| 32 | 1-4-4-4-1-26 | <i>FC:</i> Execute the “HLR CFNA De-Activation” task (see 5.4.4). |
| 33 | 1-4-4-4-1-27 | IF the PointOfReturn is indicated: |
| 34 | | GOTO RFCPointOfReturn. |
| 35 | 1-4-4-4-1-28 | ENDIF. |
| 36 | 1-4-4-4-1-28-1 | <i>FC:</i> Execute the “HLR CFU Activation.” task (see 5.5.3). |
| 37 | 1-4-4-4-1-29 | IF the PointOfReturn is indicated: |
| 38 | | GOTO RFCPointOfReturn. |
| 39 | 1-4-4-4-1-29 | ENDIF. |
| 40 | 1-4-4-4-1-30 | <i>FC:</i> Execute the “HLR CFU Activation.” task (see 5.5.3). |
| 41 | 1-4-4-4-1-31 | IF the PointOfReturn is indicated: |
| 42 | | GOTO RFCPointOfReturn. |
| 43 | 1-4-4-4-1-31-1 | ENDIF. |
| 44 | 1-4-4-4-1-32 | <i>FC:</i> Execute the “HLR CFU De-Activation.” task (see 5.5.4). |
| 45 | 1-4-4-4-1-33 | IF the PointOfReturn is indicated: |
| 46 | | GOTO RFCPointOfReturn. |
| 47 | 1-4-4-4-1-34 | ENDIF. |
| 48 | 1-4-4-4-1-34-1 | <i>FC:</i> Execute the “HLR CW Activation” task (see 5.7.1). |
| 49 | 1-4-4-4-1-35 | IF the PointOfReturn is indicated: |
| 50 | | GOTO RFCPointOfReturn. |
| 51 | 1-4-4-4-1-35 | ENDIF. |
| 52 | 1-4-4-4-1-36 | <i>FC:</i> Execute the “HLR CW Activation” task (see 5.7.1). |
| 53 | 1-4-4-4-1-37 | IF the PointOfReturn is indicated: |
| 54 | | GOTO RFCPointOfReturn. |
| 55 | 1-4-4-4-1-37-1 | ENDIF. |
| 56 | 1-4-4-4-1-38 | |
| 57 | | |
| 58 | | |
| 59 | | |
| 60 | | |

| | | |
|----------------|---|----|
| 1-4-4-4-1-39 | <i>FC:</i> Execute the “HLR CW De-Activation” task (see 5.7.2). | 1 |
| 1-4-4-4-1-40 | IF the PointOfReturn is indicated: | 2 |
| 1-4-4-4-1-40-1 | GOTO RFCPointOfReturn. | 3 |
| 1-4-4-4-1-41 | ENDIF. | 4 |
| 1-4-4-4-1-42 | <i>FC:</i> Execute the “HLR DND Activation” task (see 5.11.1). | 5 |
| 1-4-4-4-1-43 | IF the PointOfReturn is indicated: | 6 |
| 1-4-4-4-1-43-1 | GOTO RFCPointOfReturn. | 7 |
| 1-4-4-4-1-44 | ENDIF. | 8 |
| 1-4-4-4-1-45 | <i>FC:</i> Execute the “HLR DND De-Activation” task (see 5.11.2). | 9 |
| 1-4-4-4-1-46 | IF the PointOfReturn is indicated: | 10 |
| 1-4-4-4-1-46-1 | GOTO RFCPointOfReturn. | 11 |
| 1-4-4-4-1-47 | ENDIF. | 12 |
| 1-4-4-4-1-48 | <i>FC:</i> Execute the “HLR FA Membership Activation” task (see 5.12.1). | 13 |
| 1-4-4-4-1-49 | IF the PointOfReturn is indicated: | 14 |
| 1-4-4-4-1-49-1 | GOTO RFCPointOfReturn. | 15 |
| 1-4-4-4-1-50 | ENDIF. | 16 |
| 1-4-4-4-1-51 | <i>FC:</i> Execute the “HLR FA Membership De-Activation” task (see 5.12.2). | 17 |
| 1-4-4-4-1-52 | IF the PointOfReturn is indicated: | 18 |
| 1-4-4-4-1-52-1 | GOTO RFCPointOfReturn. | 19 |
| 1-4-4-4-1-53 | ENDIF. | 20 |
| 1-4-4-4-1-54 | <i>FC:</i> Execute the “HLR MWN Demand Pip Tone Activation” task (see 5.13.1). | 21 |
| 1-4-4-4-1-55 | IF the PointOfReturn is indicated: | 22 |
| 1-4-4-4-1-55-1 | GOTO RFCPointOfReturn. | 23 |
| 1-4-4-4-1-56 | ENDIF. | 24 |
| 1-4-4-4-1-57 | <i>FC:</i> Execute the “HLR MWN Demand Pip Tone De-Activation” task (see 5.13.2). | 25 |
| 1-4-4-4-1-58 | IF the PointOfReturn is indicated: | 26 |
| 1-4-4-4-1-58-1 | GOTO RFCPointOfReturn. | 27 |
| 1-4-4-4-1-59 | ENDIF. | 28 |
| 1-4-4-4-1-60 | <i>FC:</i> Execute the “HLR MWN Demand Alert Pip Tone Activation” task (see 5.13.4). | 29 |
| 1-4-4-4-1-61 | IF the PointOfReturn is indicated: | 30 |
| 1-4-4-4-1-61-1 | GOTO RFCPointOfReturn. | 31 |
| 1-4-4-4-1-62 | ENDIF. | 32 |
| 1-4-4-4-1-63 | <i>FC:</i> Execute the “HLR MWN Demand Alert Pip Tone De-Activation” task (see 5.13.5). | 33 |
| 1-4-4-4-1-64 | IF the PointOfReturn is indicated: | 34 |
| 1-4-4-4-1-64-1 | GOTO RFCPointOfReturn. | 35 |
| 1-4-4-4-1-65 | ENDIF. | 36 |

| | | |
|----|----------------|--|
| 1 | 1-4-4-4-1-66 | <i>FC:</i> Execute the “HLR MAH Demand Ordering Registration” task (see 5.14.1). |
| 2 | | |
| 3 | 1-4-4-4-1-67 | IF the PointOfReturn is indicated: |
| 4 | | |
| 5 | 1-4-4-4-1-67-1 | GOTO RFCPointOfReturn. |
| 6 | | |
| 7 | 1-4-4-4-1-68 | ENDIF. |
| 8 | 1-4-4-4-1-69 | <i>FC:</i> Execute the “HLR MAH Membership Activation” task (see 5.14.2). |
| 9 | | |
| 10 | 1-4-4-4-1-70 | IF the PointOfReturn is indicated: |
| 11 | | |
| 12 | 1-4-4-4-1-70-1 | GOTO RFCPointOfReturn. |
| 13 | | |
| 14 | 1-4-4-4-1-71 | ENDIF. |
| 15 | 1-4-4-4-1-72 | <i>FC:</i> Execute the “HLR MAH Membership De-Activation” task (see 5.14.3). |
| 16 | | |
| 17 | 1-4-4-4-1-73 | IF the PointOfReturn is indicated: |
| 18 | | |
| 19 | 1-4-4-4-1-73-1 | GOTO RFCPointOfReturn. |
| 20 | | |
| 21 | 1-4-4-4-1-74 | ENDIF. |
| 22 | 1-4-4-4-1-75 | <i>FC:</i> Execute the “HLR PCA Password Registration” task (see 5.15.3). |
| 23 | | |
| 24 | 1-4-4-4-1-76 | IF the PointOfReturn is indicated: |
| 25 | | |
| 26 | 1-4-4-4-1-76-1 | GOTO RFCPointOfReturn. |
| 27 | | |
| 28 | 1-4-4-4-1-77 | ENDIF. |
| 29 | 1-4-4-4-1-78 | <i>FC:</i> Execute the “HLR PCA Password De-Registration” task (see 5.15.4). |
| 30 | | |
| 31 | 1-4-4-4-1-79 | IF the PointOfReturn is indicated: |
| 32 | | |
| 33 | 1-4-4-4-1-79-1 | GOTO RFCPointOfReturn. |
| 34 | | |
| 35 | 1-4-4-4-1-80 | ENDIF. |
| 36 | 1-4-4-4-1-81 | <i>FC:</i> Execute the “HLR PCA Activation” task (see 5.15.5). |
| 37 | 1-4-4-4-1-82 | IF the PointOfReturn is indicated: |
| 38 | | |
| 39 | 1-4-4-4-1-82-1 | GOTO RFCPointOfReturn. |
| 40 | | |
| 41 | 1-4-4-4-1-83 | ENDIF. |
| 42 | 1-4-4-4-1-84 | <i>FC:</i> Execute the “HLR PCA De-Activation” task (see 5.15.6). |
| 43 | | |
| 44 | 1-4-4-4-1-85 | IF the PointOfReturn is indicated: |
| 45 | | |
| 46 | 1-4-4-4-1-85-1 | GOTO RFCPointOfReturn. |
| 47 | | |
| 48 | 1-4-4-4-1-86 | ENDIF. |
| 49 | 1-4-4-4-1-87 | <i>FC:</i> Execute the “HLR PL Language Registration” task (see 5.16.1). |
| 50 | | |
| 51 | 1-4-4-4-1-88 | IF the PointOfReturn is indicated: |
| 52 | | |
| 53 | 1-4-4-4-1-88-1 | GOTO RFCPointOfReturn. |
| 54 | | |
| 55 | 1-4-4-4-1-89 | ENDIF. |
| 56 | 1-4-4-4-1-90 | <i>FC:</i> Execute the “HLR SCA Number Registration” task (see 5.19.3). |
| 57 | | |
| 58 | 1-4-4-4-1-91 | IF the PointOfReturn is indicated: |
| 59 | | |
| 60 | 1-4-4-4-1-91-1 | GOTO RFCPointOfReturn. |

| | | |
|-----------------|--|----|
| 1-4-4-4-1-92 | ENDIF. | 1 |
| 1-4-4-4-1-93 | <i>FC:</i> Execute the “HLR SCA Number De-Registration” task (see 5.19.4). | 2 |
| | | 3 |
| | | 4 |
| 1-4-4-4-1-94 | IF the PointOfReturn is indicated: | 5 |
| 1-4-4-4-1-94-1 | GOTO RFCPointOfReturn. | 6 |
| | | 7 |
| 1-4-4-4-1-95 | ENDIF. | 8 |
| 1-4-4-4-1-96 | <i>FC:</i> Execute the “HLR SCA Activation” task (see 5.19.5). | 9 |
| | | 10 |
| 1-4-4-4-1-97 | IF the PointOfReturn is indicated: | 11 |
| 1-4-4-4-1-97-1 | GOTO RFCPointOfReturn. | 12 |
| | | 13 |
| 1-4-4-4-1-98 | ENDIF. | 14 |
| 1-4-4-4-1-99 | <i>FC:</i> Execute the “HLR SCA De-Activation” task (see 5.19.6). | 15 |
| | | 16 |
| 1-4-4-4-1-100 | IF the PointOfReturn is indicated: | 17 |
| 1-4-4-4-1-100-1 | GOTO RFCPointOfReturn. | 18 |
| | | 19 |
| 1-4-4-4-1-101 | ENDIF. | 20 |
| 1-4-4-4-1-102 | <i>FC:</i> Execute the “HLR SPINA Registration” task (see 5.20.1). | 21 |
| | | 22 |
| 1-4-4-4-1-103 | IF the PointOfReturn is indicated: | 23 |
| 1-4-4-4-1-103-1 | GOTO RFCPointOfReturn. | 24 |
| | | 25 |
| 1-4-4-4-1-104 | ENDIF. | 26 |
| 1-4-4-4-1-105 | <i>FC:</i> Execute the “HLR SPINA Activation” task (see 5.20.2). | 27 |
| | | 28 |
| 1-4-4-4-1-106 | IF the PointOfReturn is indicated: | 29 |
| 1-4-4-4-1-106-1 | GOTO RFCPointOfReturn. | 30 |
| | | 31 |
| 1-4-4-4-1-107 | ENDIF. | 32 |
| 1-4-4-4-1-108 | <i>FC:</i> Execute the “HLR SPINA De-Activation” task (see 5.20.3). | 33 |
| | | 34 |
| 1-4-4-4-1-109 | IF the PointOfReturn is indicated: | 35 |
| 1-4-4-4-1-109-1 | GOTO RFCPointOfReturn. | 36 |
| | | 37 |
| 1-4-4-4-1-110 | ENDIF. | 38 |
| 1-4-4-4-1-111 | <i>FC:</i> Execute the “HLR SPINI Registration” task (see 5.21.1). | 39 |
| | | 40 |
| 1-4-4-4-1-112 | IF the PointOfReturn is indicated: | 41 |
| 1-4-4-4-1-112-1 | GOTO RFCPointOfReturn. | 42 |
| | | 43 |
| 1-4-4-4-1-113 | ENDIF. | 44 |
| 1-4-4-4-1-114 | <i>FC:</i> Execute the “HLR VMR VoiceMailboxPIN Registration” task (see 5.23.1). | 45 |
| | | 46 |
| 1-4-4-4-1-115 | IF the PointOfReturn is indicated: | 47 |
| 1-4-4-4-1-115-1 | GOTO RFCPointOfReturn. | 48 |
| | | 49 |
| 1-4-4-4-1-116 | ENDIF. | 50 |
| 1-4-4-4-1-117 | <i>DEFAULT</i> (the Digits (Dialed) parameter does not contain a recognized feature code): | 51 |
| | | 52 |
| | | 53 |
| | | 54 |
| | | 55 |
| | | 56 |
| | | 57 |
| | | 58 |
| | | 59 |
| | | 60 |

| | | |
|----|-----------------|--|
| 1 | 1-4-4-4-1-117-1 | Optionally, include the <i>AnnouncementCode</i> parameter in the <i>AnnouncementList</i> parameter set to an appropriate announcement. |
| 2 | | |
| 3 | | |
| 4 | | |
| 5 | 1-4-4-4-1-117-2 | Set the <i>PointOfReturn</i> to <i>ToneTermination</i> . |
| 6 | 1-4-4-4-1-117-3 | Return to the calling task via the <i>PointOfReturn</i> . |
| 7 | 1-4-4-4-1-117-4 | (Disallow any remaining digits) |
| 8 | | |
| 9 | 1-4-4-4-1-118 | ENDCASE. |
| 10 | | |
| 11 | O | |
| 12 | | (Announcement codes may be accumulated for next <i>RemoteUserInteractionDirective</i> INVOKE or <i>FeatureRequest</i> RETURN RESULT, <i>OriginationRequest</i> RETURN RESULT). |
| 13 | | |
| 14 | | |
| 15 | 1-4-4-4-2 | ENDWHILE. |
| 16 | 1-4-4-4-3 | IF more feature code entries are allowed: |
| 17 | | |
| 18 | 1-4-4-4-3-1 | GOTO Enter Feature Code. |
| 19 | | |
| 20 | 1-4-4-4-4 | ELSE: |
| 21 | 1-4-4-4-4-1 | Optionally, include the <i>AnnouncementCode</i> parameter in the <i>AnnouncementList</i> parameter set to an appropriate announcement. |
| 22 | | |
| 23 | | |
| 24 | 1-4-4-4-4-2 | Set <i>PointOfReturn</i> to <i>ToneTermination</i> . |
| 25 | 1-4-4-4-4-3 | Return to calling task via the <i>PointOfReturn</i> . |
| 26 | | |
| 27 | 1-4-4-4-5 | ENDIF. |
| 28 | 1-4-4-5 | ELSEIF the call was abandoned (no <i>Digits (Dialed)</i> parameter was received): |
| 29 | | |
| 30 | | |
| 31 | 1-4-4-5-1 | Set <i>PointOfReturn</i> to <i>ToneTermination</i> . |
| 32 | 1-4-4-5-2 | Return to calling task via the <i>PointOfReturn</i> . |
| 33 | | |
| 34 | 1-4-4-6 | ELSE (no number was dialed, i.e., the <i>Digits (Dialed)</i> parameter contains no digits): |
| 35 | | |
| 36 | 1-4-4-6-1 | Optionally, include the <i>AnnouncementCode</i> parameter in the <i>AnnouncementList</i> parameter set to an appropriate announcement. |
| 37 | | |
| 38 | 1-4-4-6-2 | Set <i>PointOfReturn</i> to <i>ToneTermination</i> . |
| 39 | 1-4-4-6-3 | Return to calling task via the <i>PointOfReturn</i> . |
| 40 | | |
| 41 | 1-4-4-7 | ENDIF. |
| 42 | 1-4-5 | ELSEIF the call was abandoned (no <i>digits</i> parameter): |
| 43 | | |
| 44 | 1-4-5-1 | Set <i>PointOfReturn</i> to <i>ToneTermination</i> . |
| 45 | 1-4-5-2 | Return to calling task via the <i>PointOfReturn</i> . |
| 46 | | |
| 47 | 1-4-6 | ELSE: |
| 48 | | (Retries are possible here.) |
| 49 | | |
| 50 | 1-4-6-1 | Optionally, include the <i>AnnouncementCode</i> parameter in the <i>AnnouncementList</i> parameter set to an appropriate announcement. |
| 51 | | |
| 52 | 1-4-6-2 | Set <i>PointOfReturn</i> to <i>ToneTermination</i> . |
| 53 | | |
| 54 | 1-4-7 | ENDIF. |
| 55 | 1-5 | ELSEIF the call was abandoned (no <i>digits</i> parameter): |
| 56 | | |
| 57 | 1-5-1 | Set <i>PointOfReturn</i> to <i>ToneTermination</i> . |
| 58 | | |
| 59 | | |
| 60 | | |

- 1-5-2 Return to calling task via the PointOfReturn. 1
- 1-6 ELSEIF a Digits (Dialed) parameter is received AND IF the Digits (Dialed) parameter contains no digits: 2
- 1-6-1 Optionally provide for routing of call to human operator for assistance. 3
- 1-7 ELSE: 4
- (Retries are possible here.) 5
- (it may be desirable from a security point of view to accept unacceptable directory numbers and to reject the directory number-PIN pairs to avoid exposing acceptable directory numbers.) 6
- 1-7-1 Optionally, include the AnnouncementCode parameter in the AnnouncementList parameter set to an appropriate announcement. 7
- 1-7-2 Set PointOfReturn to *ToneTermination*. 8
- 1-8 ENDIF. 9
- 2 ELSE (transaction is not *RemoteUserInteraction* capable): 10
- 2-1 Optionally, include the AnnouncementCode parameter in the AnnouncementList parameter set to an appropriate announcement. 11
- 2-2 Set PointOfReturn to *ToneTermination*. 12
- 3 ENDIF. 13
- 4 Return to calling task via the PointOfReturn. 14

5.19 SELECTIVE CALL ACCEPTANCE (SCA) 15

5.19.1 HLR SCA Diversion Number Registration 16

Upon request, the HLR shall do the following: 17

- 1 IF SCA Demand Diversion Number Registration is authorized: 18
- 1-1 IF the termination address is acceptable: 19
- 1-1-1 Execute the “HLR SPINI Feature Request Invocation” task (see 5.21.4). 20
- 1-1-2 IF the SPINI invocation *failed*: 21
- 1-1-2-1 Include the FeatureResult parameter set to *Unsuccessful* to indicate unsuccessful feature operation. 22
- 1-1-2-2 Return to the calling task via the PointOfReturn. 23
- 1-1-3 ENDIF. 24
- 1-1-4 Register the termination address as the SCA diversion number. 25
- 1-1-5 Optionally, include the AnnouncementCode parameter in the AnnouncementList parameter set to an appropriate announcement. 26
- 1-1-6 Include the FeatureResult parameter set to *Successful* to indicate successful feature operation. 27
- 1-1-7 IF activation is to occur with registration: 28
- 1-1-7-1 Activate SCA. 29
- 1-1-8 ENDIF. 30
- 1-2 ELSE: 31

- 1-2-1 Optionally, include the `AnnouncementCode` parameter in the `AnnouncementList` parameter set to an appropriate announcement.
- 1-2-2 Include the `FeatureResult` parameter set to *Unsuccessful* to indicate unsuccessful feature operation.
- 1-3 ENDIF.
- 2 ELSE:
- 2-1 Optionally, include the `AnnouncementCode` parameter in the `AnnouncementList` parameter set to an appropriate announcement.
- 2-2 Include the `FeatureResult` parameter set to *Unsuccessful* to indicate unsuccessful feature operation.
- 3 ENDIF.
- 4 Set `PointOfReturn` to *ToneTermination*.
- 5 Return to calling task via the `PointOfReturn`.

5.19.2 HLR SCA Diversion Number De-Registration

Upon request, the HLR shall do the following:

- 1 IF SCA Demand Diversion Number Registration is authorized:
- 1-1 De-Register the SCA diversion number.
- 1-2 Optionally, include the `AnnouncementCode` parameter in the `AnnouncementList` parameter set to an appropriate announcement.
- 1-3 Include the `FeatureResult` parameter set to *Successful* to indicate successful feature operation.
- 1-4 De-Activate SCA.
- 2 ELSE:
- 2-1 Optionally, include the `AnnouncementCode` parameter in the `AnnouncementList` parameter set to an appropriate announcement.
- 2-2 Include the `FeatureResult` parameter set to *Unsuccessful* to indicate unsuccessful feature operation.
- 3 ENDIF.
- 4 Set `PointOfReturn` to *ToneTermination*.
- 5 Return to calling task via the `PointOfReturn`.

5.19.3 HLR SCA Number Registration

Upon request, the HLR shall do the following:

- 1 IF SCA Demand Number Registration is authorized:
- 1-1 IF the feature modifier digits indicate *last calling party*:
- 1-1-1 Register the last calling number for SCA with an indication of *last calling party*.
- 1-1-2 Optionally, include the `AnnouncementCode` parameter in the `AnnouncementList` parameter set to an appropriate announcement.
- 1-1-3 Include the `FeatureResult` parameter set to *Successful* to indicate successful feature operation.

- 1-1-4 IF activation is to occur with registration: 1
- 1-1-4-1 Activate SCA. 2
- 1-1-5 ENDIF. 3
- 1-2 ENDIF. 4
- 1-3 IF the number is acceptable: 5
- 1-3-1 Register the number for SCA without an indication of *last calling party*. 6
- 1-3-2 Optionally, include the AnnouncementCode parameter in the AnnouncementList parameter set to an appropriate announcement. 7
- 1-3-3 Include the FeatureResult parameter set to *Successful* to indicate successful feature operation. 8
- 1-3-4 IF activation is to occur with registration: 9
- 1-3-4-1 Activate SCA. 10
- 1-3-5 ENDIF. 11
- 1-4 ELSE (number is not acceptable): 12
- 1-4-1 Optionally, include the AnnouncementCode parameter in the AnnouncementList parameter set to an appropriate announcement. 13
- 1-4-2 Include the FeatureResult parameter set to *Unsuccessful* to indicate unsuccessful feature operation. 14
- 1-5 ENDIF. 15
- 2 ELSE: 16
- 2-1 Optionally, include the AnnouncementCode parameter in the AnnouncementList parameter set to an appropriate announcement. 17
- 2-2 Include the FeatureResult parameter set to *Unsuccessful* to indicate unsuccessful feature operation. 18
- 3 ENDIF. 19
- 4 Set PointOfReturn to *ToneTermination*. 20
- 5 Return to calling task via the PointOfReturn. 21

5.19.4 HLR SCA Number De-Registration

Upon request, the HLR shall do the following:

- 1 IF SCA Demand Number Registration is authorized: 22
- 1-1 IF a specific number was specified: 23
- 1-1-1 De-Register the specified SCA number. 24
- 1-1-2 IF no more numbers are registered: 25
- 1-1-2-1 De-Activate SCA. 26
- 1-1-3 ENDIF. 27
- 1-1-4 Optionally, include the AnnouncementCode parameter in the AnnouncementList parameter set to an appropriate announcement. 28
- 1-1-5 Include the FeatureResult parameter set to *Successful* to indicate successful feature operation. 29
- 1-2 ELSEIF the all *last calling party* modifier digits were specified: 30
- 1-2-1 De-Register all SCA numbers indicating *last calling party*. 31

- 1 1-2-2 IF no more numbers are registered:
 2
 3 1-2-2-1 De-Activate SCA.
 4 1-2-3 ENDIF.
 5 1-2-4 Optionally, include the AnnouncementCode parameter in the
 6 AnnouncementList parameter set to an appropriate announcement.
 7
 8 1-2-5 Include the FeatureResult parameter set to *Successful* to indicate successful
 9 feature operation.
 10 1-3 ELSEIF the bulk de-registration modifier digits were specified:
 11 1-3-1 De-Register all SCA passwords.
 12 1-3-2 De-Activate SCA.
 13 1-3-3 Optionally, include the AnnouncementCode parameter in the
 14 AnnouncementList parameter set to an appropriate announcement.
 15 1-3-4 Include the FeatureResult parameter set to *Successful* to indicate successful
 16 feature operation.
 17 1-4 ELSE (Either no number, not last party, nor bulk deregistration was specified).
 18 1-4-1 Optionally, include the AnnouncementCode parameter in the
 19 AnnouncementList parameter set to an appropriate announcement.
 20 1-4-2 Include the FeatureResult parameter set to *Unsuccessful* to indicate
 21 unsuccessful feature operation.
 22 1-4-3 Include the FeatureResult parameter set to *Unsuccessful* to indicate
 23 unsuccessful feature operation.
 24 1-5 ENDIF.
 25 2 ELSE:
 26 2-1 Optionally, include the AnnouncementCode parameter in the AnnouncementList
 27 parameter set to an appropriate announcement.
 28 2-2 Include the FeatureResult parameter set to *Unsuccessful* to indicate unsuccessful
 29 feature operation.
 30 3 ENDIF.
 31 4 Set PointOfReturn to *ToneTermination*.
 32 5 Return to calling task via the PointOfReturn.
 33
 34
 35
 36
 37
 38

5.19.5 HLR SCA Activation

41 Upon request, the HLR shall do the following:
 42

- 43 1 IF a SCA Demand Activation is authorized:
 44 1-1 IF a SCA password is registered:
 45 1-1-1 Activate SCA.
 46 1-1-2 Optionally, include the AnnouncementCode parameter in the
 47 AnnouncementList parameter set to an appropriate announcement.
 48 1-1-3 Include the FeatureResult parameter set to *Successful* to indicate successful
 49 feature operation.
 50 1-2 ELSE:
 51 1-2-1 Optionally, include the AnnouncementCode parameter in the
 52 AnnouncementList parameter set to an appropriate announcement.
 53 1-2-2 Include the FeatureResult parameter set to *Unsuccessful* to indicate
 54 unsuccessful feature operation.
 55
 56
 57
 58
 59
 60

- 1-3 ENDIF. 1
- 2 ELSE: 2
- 2-1 Optionally, include the AnnouncementCode parameter in the AnnouncementList 3
parameter set to an appropriate announcement. 4
- 2-2 Include the FeatureResult parameter set to *Unsuccessful* to indicate unsuccessful 5
feature operation. 6
- 3 ENDIF. 7
- 4 Set PointOfReturn to *ToneTermination*. 8
- 5 Return to calling task via the PointOfReturn. 9

5.19.6 HLR SCA De-Activation

Upon request, the HLR shall do the following:

- 1 IF a SCA Demand Activation is authorized: 17
- 1-1 De-Activate SCA. 18
- 1-2 Optionally, include the AnnouncementCode parameter in the AnnouncementList 19
parameter set to an appropriate announcement. 20
- 1-3 Include the FeatureResult parameter set to *Successful* to indicate successful feature 21
operation. 22
- 2 ELSE: 23
- 2-1 Optionally, include the AnnouncementCode parameter in the AnnouncementList 24
parameter set to an appropriate announcement. 25
- 2-2 Include the FeatureResult parameter set to *Unsuccessful* to indicate unsuccessful 26
feature operation. 27
- 3 ENDIF. 28
- 4 Set PointOfReturn to *ToneTermination*. 29
- 5 Return to calling task via the PointOfReturn. 30

5.19.7 HLR SCA Incoming Call Invocation

Upon request, the HLR shall do the following:

- 1 IF SCA is active: 40
- 1-1 IF the incoming call has calling number identification: 41
- 1-1-1 IF the calling number does not match a number on the SCA list (i.e., the call is 42
refused): 43
- 1-1-1-1 Set PointOfReturn to *Accepted*. 44
- 1-1-2 ELSE (the call is refused based on CNI): 45
- 1-1-2-1 IF PCA is active: 46
- 1-1-2-1-1 (Allow the call to continue.) 47
- 1-1-2-2 ELSE (call is refused and PCA is not active): 48
- 1-1-2-2-1 IF the MS has an SCA diversion number active: 49
- 1-1-2-2-1-1 Execute the “HLR Select Forward-To or Diversion Number 50
Point of Return” task (see 6.1.2). 51

- 1-1-2-2-1-2 Include the DMH_RedirectionIndicator parameter set to *SCA call refused*.
- 1-1-2-2-2 ELSE (use the system default refusal treatment):
- 1-1-2-2-2-1 Optionally, include the AnnouncementCode parameter in the AnnouncementList parameter set to an appropriate announcement.
- 1-1-2-2-2-2 Set PointOfReturn to *ToneTermination*.
- 1-1-2-2-3 ENDIF.
- 1-1-2-3 ENDIF.
- 1-1-3 ENDIF.
- 1-2 ELSE (the call is refused based on no CNI):
- 1-2-1 IF the MS has an SCA diversion number active:
- 1-2-1-1 Execute the “HLR Select Forward-To or Diversion Number Point of Return” task (see 6.1.2).
- 1-2-1-2 Include the DMH_RedirectionIndicator parameter set to *SCA call refused*.
- 1-2-2 ELSE (use the system default refusal treatment):
- 1-2-2-1 Optionally, include the AnnouncementCode parameter in the AnnouncementList parameter set to an appropriate announcement.
- 1-2-2-2 Set PointOfReturn to *ToneTermination*.
- 1-2-3 ENDIF.
- 1-3 ENDIF.
- 2 ELSE (SCA is not active):
- 2-1 (Allow the call to continue.)
- 3 ENDIF.
- 4 Return to calling task via the PointOfReturn.

5.20 SUBSCRIBER PIN ACCESS (SPINA)

SPINA alters the subscriber’s active profile information to change a subscriber’s access privileges. When SPINA is active, the subscriber is given a restricted service profile. When SPINA is not active, the subscriber is given its normal service profile.

5.20.1 HLR SPINA Registration

Upon request, the HLR shall do the following:

- 1 IF SPINA Variable Registration is authorized:
- 1-1 IF the TransactionCapability parameter received with the FeatureRequest INVOKE indicates *RemoteUserInteraction* capable:
- 1-1-1 Include the AnnouncementCode parameter in the AnnouncementList parameter set to prompt the calling party to enter the old PIN.
- 1-1-2 Include the DigitCollectionControl parameter set appropriately.

| | | |
|---------------|---|----|
| 1-1-3 | Execute a “HLR Initiating a Remote User Interaction Directive” task (see 4.39.1). | 1 |
| | | 2 |
| 1-1-4 | IF the received Digits (Dialed) parameter contains the existing PIN: | 3 |
| | | 4 |
| 1-1-4-1 | Include the AnnouncementCode parameter in the AnnouncementList parameter set to prompt the calling party to enter a new PIN. | 5 |
| | | 6 |
| 1-1-4-2 | Include the DigitCollectionControl parameter set appropriately. | 7 |
| | | 8 |
| 1-1-4-3 | Execute a “HLR Initiating a Remote User Interaction Directive” task (see 4.39.1). | 9 |
| | | 10 |
| 1-1-4-4 | IF the received Digits (Dialed) parameter contains an acceptable new PIN: | 11 |
| | | 12 |
| | | 13 |
| 1-1-4-4-1 | Include the AnnouncementCode parameter in the AnnouncementList parameter set to prompt the calling party to re-enter the new PIN. | 14 |
| | | 15 |
| 1-1-4-4-2 | Include the DigitCollectionControl parameter set appropriately. | 16 |
| | | 17 |
| 1-1-4-4-3 | Execute a “HLR Initiating a Remote User Interaction Directive” task (see 4.39.1). | 18 |
| | | 19 |
| 1-1-4-4-4 | IF the received Digits (Dialed) parameter contains the same as the first entry of the PIN: | 20 |
| | | 21 |
| | | 22 |
| 1-1-4-4-4-1 | Register the PIN. | 23 |
| | | 24 |
| 1-1-4-4-4-2 | Optionally, include the AnnouncementCode parameter in the AnnouncementList parameter set to an appropriate announcement. | 25 |
| | | 26 |
| 1-1-4-4-4-3 | Include the FeatureResult parameter set to <i>Successful</i> to indicate successful feature operation. | 27 |
| | | 28 |
| 1-1-4-4-4-4 | IF activation is to occur with registration: | 29 |
| | | 30 |
| 1-1-4-4-4-4-1 | Activate SPINA. | 31 |
| | | 32 |
| 1-1-4-4-4-5 | ENDIF. | 33 |
| | | 34 |
| 1-1-4-4-4-6 | Set PointOfReturn to <i>ToneTermination</i> . | 35 |
| | | 36 |
| 1-1-4-4-5 | ELSEIF the call was abandoned (no Digits (Dialed) parameter was received): | 37 |
| | | 38 |
| 1-1-4-4-5-1 | Set PointOfReturn to <i>ToneTermination</i> . | 39 |
| | | 40 |
| 1-1-4-4-6 | ELSE (bad second entry of PIN or the Digits (Dialed) parameter contains no digits): | 41 |
| | | 42 |
| | (Retries are possible here.) | 43 |
| | | 44 |
| 1-1-4-4-6-1 | Include the FeatureResult parameter set to <i>Unsuccessful</i> to indicate unsuccessful feature operation. | 45 |
| | | 46 |
| 1-1-4-4-6-2 | Optionally, include the AnnouncementCode parameter in the AnnouncementList parameter set to an appropriate announcement. | 47 |
| | | 48 |
| 1-1-4-4-7 | ENDIF. | 49 |
| | | 50 |
| 1-1-4-5 | ELSEIF the call was abandoned (no Digits (Dialed) parameter is received): | 51 |
| | | 52 |
| 1-1-4-5-1 | Set PointOfReturn to <i>ToneTermination</i> . | 53 |
| | | 54 |
| 1-1-4-6 | ELSE (unacceptable new PIN or the Digits (Dialed) parameter contains no digits): | 55 |
| | | 56 |
| | (Retries are possible here.) | 57 |
| | | 58 |
| | | 59 |
| | | 60 |

- 1-1-4-6-1 Optionally, include the *AnnouncementCode* parameter in the *AnnouncementList* parameter set to an appropriate announcement.
- 1-1-4-6-2 Include the *FeatureResult* parameter set to *Unsuccessful* to indicate unsuccessful feature operation.
- 1-1-4-6-3 Set *PointOfReturn* to *ToneTermination*.
- 1-1-4-7 ENDIF.
- 1-1-5 ELSEIF the call was abandoned (no parameter was received):
- 1-1-5-1 Set *PointOfReturn* to *ToneTermination*.
- 1-1-6 ELSE (incorrect PIN entered or the *Digits (Dialed)* parameter contains no digits):
- (Retries are possible here.)
- 1-1-6-1 Optionally, include the *AnnouncementCode* parameter in the *AnnouncementList* parameter set to an appropriate announcement.
- 1-1-6-2 Include the *FeatureResult* parameter set to *Unsuccessful* to indicate unsuccessful feature operation.
- 1-1-6-3 Set *PointOfReturn* to *ToneTermination*.
- 1-1-7 ENDIF.
- 1-2 ELSE (transaction is not *RemoteUserInteraction* capable):
- 1-2-1 Optionally, include the *AnnouncementCode* parameter in the *AnnouncementList* parameter set to an appropriate announcement.
- 1-2-2 Include the *FeatureResult* parameter set to *Unsuccessful* to indicate unsuccessful feature operation.
- 1-2-3 Set *PointOfReturn* to *ToneTermination*.
- 1-3 ENDIF.
- 2 ELSE (SPINA Variable Registration is not authorized):
- 2-1 Optionally, include the *AnnouncementCode* parameter in the *AnnouncementList* parameter set to an appropriate announcement.
- 2-2 Include the *FeatureResult* parameter set to *Unsuccessful* to indicate unsuccessful feature operation.
- 2-3 Set *PointOfReturn* to *ToneTermination*.
- 3 ENDIF.
- 4 Return to calling task via the *PointOfReturn*.

5.20.2 HLR SPINA Activation

Upon request, the HLR shall do the following:

- 1 IF SPINA Activation is authorized:
- 1-1 IF the *TransactionCapability* parameter received in the *FeatureRequest INVOKE* indicates *RemoteUserInteraction* capable:
- 1-1-1 Include the *AnnouncementCode* parameter in the *AnnouncementList* parameter set to prompt the calling party to enter the PIN.
- 1-1-2 Include the *DigitCollectionControl* parameter set appropriately.
- 1-1-3 Execute a “HLR Initiating a Remote User Interaction Directive” task (see 4.39.1).

| | | |
|---------|--|----|
| 1-1-4 | IF the received parameter contains the existing PIN: | 1 |
| 1-1-4-1 | Activate SPINA. | 2 |
| 1-1-4-2 | Optionally, include the AnnouncementCode parameter in the AnnouncementList parameter set to an appropriate announcement. | 3 |
| 1-1-4-3 | Include the FeatureResult parameter set to <i>Successful</i> to indicate successful feature operation. | 4 |
| 1-1-4-4 | Set PointOfReturn to <i>ToneTermination</i> . | 5 |
| 1-1-5 | ELSEIF the call was abandoned (no Digits (Dialed) parameter was received): | 6 |
| 1-1-5-1 | Set PointOfReturn to <i>ToneTermination</i> . | 7 |
| 1-1-6 | ELSE (incorrect PIN entered or the Digits (Dialed) parameter contains no digits): | 8 |
| | (Retries are possible here.) | 9 |
| 1-1-6-1 | Optionally, include the AnnouncementCode parameter in the AnnouncementList parameter set to an appropriate announcement. | 10 |
| 1-1-6-2 | Include the FeatureResult parameter set to <i>Unsuccessful</i> to indicate unsuccessful feature operation. | 11 |
| 1-1-6-3 | Set PointOfReturn to <i>ToneTermination</i> . | 12 |
| 1-1-7 | ENDIF. | 13 |
| 1-2 | ELSE (transaction is not <i>RemoteUserInteraction</i> capable): | 14 |
| 1-2-1 | Optionally, include the AnnouncementCode parameter in the AnnouncementList parameter set to an appropriate announcement. | 15 |
| 1-2-2 | Include the FeatureResult parameter set to <i>Unsuccessful</i> to indicate unsuccessful feature operation. | 16 |
| 1-2-3 | Set PointOfReturn to <i>ToneTermination</i> . | 17 |
| 1-3 | ENDIF. | 18 |
| 2 | ELSE (SPINA Activation is not authorized): | 19 |
| 2-1 | Optionally, include the AnnouncementCode parameter in the AnnouncementList parameter set to an appropriate announcement. | 20 |
| 2-2 | Include the FeatureResult parameter set to <i>Unsuccessful</i> to indicate unsuccessful feature operation. | 21 |
| 2-3 | Set PointOfReturn to <i>ToneTermination</i> . | 22 |
| 3 | ENDIF. | 23 |
| 4 | Return to calling task via the PointOfReturn. | 24 |

5.20.3 HLR SPINA De-Activation

Upon request, the HLR shall do the following:

- 1 IF SPINA Activation is authorized:
 - 1-1 IF the TransactionCapability parameter received in the FeatureRequest INVOKE indicates *RemoteUserInteraction* capable:
 - 1-1-1 Include the AnnouncementCode parameter in the AnnouncementList parameter set to prompt the calling party to enter the PIN.
 - 1-1-2 Include the DigitCollectionControl parameter set appropriately.

- 1-1-3 Execute a “HLR Initiating a Remote User Interaction Directive” task (see 4.39.1).
- 1-1-4 IF the received Digits (Dialed) parameter contains the existing PIN:
- 1-1-4-1 De-activate SPINA.
- 1-1-4-2 Optionally, include the AnnouncementCode parameter in the AnnouncementList parameter set to an appropriate announcement.
- 1-1-4-3 Set PointOfReturn to *ToneTermination*.
- 1-1-5 ELSEIF the call was abandoned (no Digits (Dialed) parameter was received):
- 1-1-5-1 Set PointOfReturn to *ToneTermination*.
- 1-1-6 ELSE (incorrect PIN entered or the Digits (Dialed) parameter contains no digits):
- (Retries are possible here.)
- 1-1-6-1 Optionally, include the AnnouncementCode parameter in the AnnouncementList parameter set to an appropriate announcement.
- 1-1-6-2 Include the FeatureResult parameter set to *Unsuccessful* to indicate unsuccessful feature operation.
- 1-1-6-3 Set PointOfReturn to *ToneTermination*.
- 1-1-7 ENDIF.
- 1-2 ELSE (transaction is not *RemoteUserInteraction* capable):
- 1-2-1 Optionally, include the AnnouncementCode parameter in the AnnouncementList parameter set to an appropriate announcement.
- 1-2-2 Include the FeatureResult parameter set to *Unsuccessful* to indicate unsuccessful feature operation.
- 1-2-3 Set PointOfReturn to *ToneTermination*.
- 1-3 ENDIF.
- 2 ELSE (SPINA activation is not authorized):
- 2-1 Optionally, include the AnnouncementCode parameter in the AnnouncementList parameter set to an appropriate announcement.
- 2-2 Include the FeatureResult parameter set to *Unsuccessful* to indicate unsuccessful feature operation.
- 2-3 Set PointOfReturn to *ToneTermination*.
- 3 ENDIF.
- 4 Return to calling task via the PointOfReturn.

5.21 SUBSCRIBER PIN INTERCEPT (SPINI)

SPINI intercepts call origination of specified types and prompts the subscriber to enter a Personal Identification Number (PIN). Only when a correct PIN is entered is the call allowed to proceed.

5.21.1 HLR SPINI Registration

Upon request, the HLR shall do the following:

- 1 IF SPINI Variable Registration is authorized:

| | | |
|---------------|---|----|
| 1-1 | IF the TransactionCapability parameter received in the FeatureRequest INVOKE indicates <i>RemoteUserInteraction</i> capable: | 1 |
| | | 2 |
| | | 3 |
| 1-1-1 | Include the AnnouncementCode parameter in the AnnouncementList parameter set to prompt the calling party to enter the old PIN. | 4 |
| | | 5 |
| 1-1-2 | Include the DigitCollectionControl parameter set appropriately. | 6 |
| | | 7 |
| 1-1-3 | Execute a “HLR Initiating a Remote User Interaction Directive” task (see 4.39.1). | 8 |
| | | 9 |
| 1-1-4 | IF the received Digits (Dialed) parameter contains the existing PIN: | 10 |
| | | 11 |
| 1-1-4-1 | Include the AnnouncementCode parameter in the AnnouncementList parameter set to prompt the calling party to enter a new PIN. | 12 |
| | | 13 |
| 1-1-4-2 | Include the DigitCollectionControl set appropriately. | 14 |
| | | 15 |
| 1-1-4-3 | Execute a “HLR Initiating a Remote User Interaction Directive” task (see 4.39.1). | 16 |
| | | 17 |
| 1-1-4-4 | IF the received Digits (Dialed) parameter contains an acceptable PIN: | 18 |
| | | 19 |
| 1-1-4-4-1 | Include the AnnouncementCode parameter in the AnnouncementList parameter set to prompt the calling party to re-enter the new PIN. | 20 |
| | | 21 |
| 1-1-4-4-2 | Include the DigitCollectionControl parameter set appropriately. | 22 |
| | | 23 |
| 1-1-4-4-3 | Execute a “HLR Initiating a Remote User Interaction Directive” task (see 4.39.1). | 24 |
| | | 25 |
| 1-1-4-4-4 | IF the received Digits (Dialed) parameter is the same as the first entry of the PIN. | 26 |
| | | 27 |
| 1-1-4-4-4-1 | Register the PIN. | 28 |
| | | 29 |
| 1-1-4-4-4-2 | Optionally, include the AnnouncementCode parameter in the AnnouncementList parameter set to an appropriate announcement. | 30 |
| | | 31 |
| | | 32 |
| 1-1-4-4-4-3 | Include the FeatureResult parameter set to <i>Successful</i> to indicate successful feature operation. | 33 |
| | | 34 |
| 1-1-4-4-4-4 | IF activation is to occur with registration: | 35 |
| | | 36 |
| 1-1-4-4-4-4-1 | Activate SPINI. | 37 |
| | | 38 |
| 1-1-4-4-4-5 | ENDIF. | 39 |
| | | 40 |
| 1-1-4-4-4-6 | Set PointOfReturn to <i>ToneTermination</i> . | 41 |
| | | 42 |
| 1-1-4-4-5 | ELSEIF the call was abandoned (no Digits (Dialed) parameter was received): | 43 |
| | | 44 |
| 1-1-4-4-5-1 | Set PointOfReturn to <i>ToneTermination</i> . | 45 |
| | | 46 |
| 1-1-4-4-6 | ELSE (bad second entry of PIN or the Digits (Dialed) parameter contains no digits): | 47 |
| | | 48 |
| | (Retries are possible here.) | 49 |
| | | 50 |
| 1-1-4-4-6-1 | Include the FeatureResult parameter set to <i>Unsuccessful</i> to indicate unsuccessful feature operation. | 51 |
| | | 52 |
| 1-1-4-4-6-2 | Optionally, include the AnnouncementCode parameter in the AnnouncementList parameter set to an appropriate announcement. | 53 |
| | | 54 |
| 1-1-4-4-7 | ENDIF. | 55 |
| | | 56 |
| 1-1-4-5 | ELSEIF the call was abandoned (no Digits (Dialed) parameter is received): | 57 |
| | | 58 |
| | | 59 |
| | | 60 |

- 1
2
3
4
5
6
7
8
9
10
11
12
13
14
15
16
17
18
19
20
21
22
23
24
25
26
27
28
29
30
31
32
33
34
35
36
37
38
39
40
41
42
43
44
45
46
47
48
49
- 1-1-4-5-1 Set PointOfReturn to *ToneTermination*.
 - 1-1-4-6 ELSE (unacceptable PIN or the Digits (Dialed) parameter contains no digits):
 - (Retries are possible here.)
 - 1-1-4-6-1 Optionally, include the AnnouncementCode parameter in the AnnouncementList parameter set to an appropriate announcement.
 - 1-1-4-6-2 Include the FeatureResult parameter set to *Unsuccessful* to indicate unsuccessful feature operation.
 - 1-1-4-6-3 Set PointOfReturn to *ToneTermination*.
 - 1-1-4-7 ENDIF.
 - 1-1-5 ELSEIF the call was abandoned (no Digits (Dialed) parameter was received):
 - 1-1-5-1 Set PointOfReturn to *ToneTermination*.
 - 1-1-6 ELSE (incorrect PIN entered or the Digits (Dialed) parameter contains no digits):
 - (Retries are possible here.)
 - 1-1-6-1 Optionally, include the AnnouncementCode parameter in the AnnouncementList parameter set to an appropriate announcement.
 - 1-1-6-2 Include the FeatureResult parameter set to *Unsuccessful* to indicate unsuccessful feature operation.
 - 1-1-6-3 Set PointOfReturn to *ToneTermination*.
 - 1-1-7 ENDIF.
 - 1-2 ELSE (transaction is not *RemoteUserInteraction* capable):
 - 1-2-1 Optionally, include the AnnouncementCode parameter in the AnnouncementList parameter set to an appropriate announcement.
 - 1-2-2 Include the FeatureResult parameter set to *Unsuccessful* to indicate unsuccessful feature operation.
 - 1-2-3 Set PointOfReturn to *ToneTermination*.
 - 1-3 ENDIF.
 - 2 ELSE (SPINI variable Registration is not authorized):
 - 2-1 Optionally, include the AnnouncementCode parameter in the AnnouncementList parameter set to an appropriate announcement.
 - 2-2 Include the FeatureResult parameter set to *Unsuccessful* to indicate unsuccessful feature operation.
 - 2-3 Set PointOfReturn to *ToneTermination*.
 - 3 ENDIF.
 - 4 Return to calling task via the PointOfReturn.

5.21.2 HLR SPINI Originating Call Invocation

Upon request, the HLR shall do the following:

- 1 IF SPINI is active:
 - 1-1 IF an intercept criteria is met (e.g., the call type indicated by the dialed digits or received OriginationTriggers parameter, outside of a time period, on number of legs):

60

| | | |
|-----------|--|----|
| 1-1-1 | IF the TransactionCapability parameter received in the OriginationRequest INVOKE indicates <i>RemoteUserInteraction</i> capable: | 1 |
| | | 2 |
| 1-1-1-1 | Include the AnnouncementCode parameter in the AnnouncementList parameter set to prompt the calling party to enter a PIN. | 3 |
| | | 4 |
| 1-1-1-2 | Include the DigitCollectionControl parameter set appropriately. | 5 |
| | | 6 |
| 1-1-1-3 | Execute a “HLR Initiating a Remote User Interaction Directive” task (see 4.39.1). | 7 |
| | | 8 |
| 1-1-1-4 | IF the received Digits (Dialed) parameter matches the subscriber’s PIN: | 9 |
| | | 10 |
| 1-1-1-4-1 | Return to calling task. | 11 |
| | | 12 |
| 1-1-1-5 | ELSEIF the call was abandoned (no Digits (Dialed) parameter was received): | 13 |
| | | 14 |
| 1-1-1-5-1 | Set PointOfReturn to <i>ToneTermination</i> . | 15 |
| | | 16 |
| 1-1-1-6 | ELSE (incorrect PIN entered or the Digits (Dialed) parameter contains no digits): | 17 |
| | | 18 |
| | (Retries are possible here.) | 19 |
| | | 20 |
| 1-1-1-6-1 | Optionally, include the AnnouncementCode parameter in the AnnouncementList parameter set to an appropriate announcement. | 21 |
| | | 22 |
| 1-1-1-6-2 | Set PointOfReturn to <i>ToneTermination</i> . | 23 |
| | | 24 |
| 1-1-1-7 | ENDIF. | 25 |
| 1-1-2 | ELSE (transaction is not <i>RemoteUserInteraction</i> capable): | 26 |
| | | 27 |
| 1-1-2-1 | IF the call should be allowed when Remote User Interactions are not possible: | 28 |
| | | 29 |
| 1-1-2-1-1 | Return to calling task. | 30 |
| | | 31 |
| 1-1-2-2 | ELSE: | 32 |
| | | 33 |
| 1-1-2-2-1 | Optionally, include the AnnouncementCode parameter in the AnnouncementList parameter set to an appropriate announcement. | 34 |
| | | 35 |
| 1-1-2-2-2 | Set PointOfReturn to <i>ToneTermination</i> . | 36 |
| | | 37 |
| 1-1-2-3 | ENDIF. | 38 |
| 1-1-3 | ENDIF. | 39 |
| 1-2 | ELSE (call doesn’t meet an intercept criteria): | 40 |
| | | 41 |
| 1-2-1 | Return to calling task. | 42 |
| | | 43 |
| 1-3 | ENDIF. | 44 |
| 2 | ELSE (SPINI is not active): | 45 |
| | | 46 |
| 2-1 | Return to calling task. | 47 |
| | | 48 |
| 3 | ENDIF. | 49 |
| | | 50 |
| 4 | Return to calling task via the PointOfReturn. | 51 |
| | | 52 |
| | | 53 |
| | | 54 |
| | | 55 |
| | | 56 |
| | | 57 |
| | | 58 |
| | | 59 |
| | | 60 |

5.21.3 MSC SPINI Originating Call Invocation

When requested, an MSC shall perform the following tasks:

- 1 IF the SPINITriggers indicate that SPINI applies for this call type:
 - 1-1 Store the original dialed digits.
 - 1-2 Play an announcement to the originating subscriber to prompt for the SPINI PIN.

1 N N
2
3 1-3 Start a PIN collect timer for the maximum time to wait for the subscriber to wait
4 for a PIN:
5 1-4 WAIT to collect the SPINI PIN:
6
7 1-5 WHEN the PIN is collected:
8 1-5-1 Stop the PIN collect timer.
9 1-5-2 IF the entered PIN matches the subscriber's SPINI PIN:
10 1-5-2-1 Restore the original dialed digits.
11 1-5-2-2 Set the PointOfReturn to *PSTNTermination*.
12 1-5-2-3 Return to the calling task.
13 1-5-3 ELSE:
14 1-5-3-1 Give the subscriber denial treatment.
15 1-5-3-2 IF a retry is allowed (based on number of failures):
16 1-5-3-2-1 GOTO Collect SPINI PIN.
17 1-5-3-3 ELSE:
18 1-5-3-3-1 Release the call and any facilities used.
19 1-5-3-3-2 Give the subscriber denial treatment.
20 1-5-3-3-3 Set the PointOfReturn to *ToneTermination*.
21 1-5-3-4 ENDIF.
22 1-5-4 ENDIF.
23 1-6 WHEN the call is abandoned:
24 1-6-1 Stop the PIN collect timer.
25 1-6-2 Release the call and any facilities used.
26 1-7 WHEN the PIN collect timer expires:
27 1-7-1 Release the call and any facilities used.
28 1-7-2 Give the subscriber denial treatment.
29 1-7-3 Set the PointOfReturn to *ToneTermination*.
30 1-8 ENDWAIT.
31 2 ENDIF.
32 3 Return to the calling task.

5.21.4 HLR SPINI Feature Request Invocation

1 IF SPINI is active:
2 1-1 IF the termination address meets a SPINI triggering criteria (e.g., the call type
3 indicated by the dialed digits, outside of a time period, on number of legs):
4 1-1-1 IF the TransactionCapability parameter received in the OriginationRequest
5 INVOKE indicates *RemoteUserInteraction* capable:
6 1-1-1-1 Include the AnnouncementCode parameter in the AnnouncementList
7 parameter set to prompt the calling party to enter a PIN.
8 1-1-1-2 Include the DigitCollectionControl parameter set appropriately.
9 1-1-1-3 Execute a "HLR Initiating a Remote User Interaction Directive" task (see
10 4.39.1).

| | | |
|-----------|--|----|
| 1-1-1-4 | IF the received Digits (Dialed) parameter matches the subscriber's PIN: | 1 |
| 1-1-1-4-1 | Return to calling task indicating <i>success</i> . | 2 |
| 1-1-1-5 | ELSEIF the call was abandoned (no Digits (Dialed) parameter was received): | 3 |
| 1-1-1-5-1 | Return to calling task indicating <i>failure</i> . | 4 |
| 1-1-1-6 | ELSE (incorrect PIN entered or the Digits (Dialed) parameter contains no digits): | 5 |
| | (Retries are possible here.) | 6 |
| 1-1-1-6-1 | Optionally, include the AnnouncementCode parameter in the AnnouncementList parameter set to an appropriate announcement. | 7 |
| 1-1-1-6-2 | Return to calling task indicating <i>failure</i> . | 8 |
| 1-1-1-7 | ENDIF. | 9 |
| 1-1-2 | ELSE (transaction is not <i>RemoteUserInteraction</i> capable): | 10 |
| 1-1-2-1 | IF the call should be allowed when Remote User Interactions are not possible: | 11 |
| 1-1-2-1-1 | Return to calling task indicating <i>success</i> . | 12 |
| 1-1-2-2 | ELSE: | 13 |
| 1-1-2-2-1 | Optionally, include the AnnouncementCode parameter in the AnnouncementList parameter set to an appropriate announcement. | 14 |
| 1-1-2-2-2 | Return to calling task indicating <i>failure</i> . | 15 |
| 1-1-2-3 | ENDIF. | 16 |
| 1-1-3 | ENDIF. | 17 |
| 1-2 | ELSE (call doesn't meet an intercept criteria): | 18 |
| 1-2-1 | Return to calling task indicating <i>success</i> . | 19 |
| 1-3 | ENDIF. | 20 |
| 2 | ELSE (SPINI is not active): | 21 |
| 2-1 | Return to calling task indicating <i>success</i> . | 22 |
| 3 | ENDIF. | 23 |
| 4 | Return to calling task indicating <i>success</i> . | 24 |

5.22 THREE-WAY CALLING (3WC)

Three-Way Calling is controlled by the call processing in the Anchor MSC in a manner consistent with *IS-53*. Three-Way Calling is enabled with a CallingFeaturesIndicator Feature Mask value in the subscriber's service profile. See 3.2.2.

5.23 VOICE MESSAGE RETRIEVAL (VMR)

5.23.1 HLR VMR VoiceMailboxPIN Registration

Upon request, the HLR shall do the following:

- 1 IF VMR VoiceMailboxPIN Registration is authorized:
 - 1-1 IF the TransactionCapability parameter received in the FeatureRequest INVOKE indicates *RemoteUserInteraction* capable:
 - 1-1-1 Include the AnnouncementCode parameter in the AnnouncementList parameter set to prompt the calling party to enter the old VoiceMailboxPIN.
 - 1-1-2 Include the DigitCollectionControl parameter set appropriately.
 - 1-1-3 Execute a “HLR Initiating a Remote User Interaction Directive” task (see 4.39.1).
 - 1-1-4 IF the received Digits (Dialed) parameter contains the existing VoiceMailboxPIN:
 - 1-1-4-1 Include the AnnouncementCode parameter in the AnnouncementList parameter set to prompt the calling party to enter a new VoiceMailboxPIN.
 - 1-1-4-2 Include the DigitCollectionControl parameter set appropriately.
 - 1-1-4-3 Execute a “HLR Initiating a Remote User Interaction Directive” task (see 4.39.1).
 - 1-1-4-4 IF the received Digits (Dialed) parameter contains an acceptable VoiceMailboxPIN:
 - 1-1-4-4-1 Include the AnnouncementCode parameter in the AnnouncementList parameter set to prompt the calling party to re-enter the new VoiceMailboxPIN.
 - 1-1-4-4-2 Include the DigitCollectionControl parameter set appropriately.
 - 1-1-4-4-3 Execute a “HLR Initiating a Remote User Interaction Directive” task (see 4.39.1).
 - 1-1-4-4-4 IF the received Digits (Dialed) parameter contains the same as the first entry of the VoiceMailboxPIN:
 - 1-1-4-4-4-1 Register the VoiceMailboxPIN.
 - 1-1-4-4-4-2 Optionally, include the AnnouncementCode parameter in the AnnouncementList parameter set to an appropriate announcement.
 - 1-1-4-4-4-3 Include the FeatureResult parameter set to *Successful* to indicate successful feature operation.
 - 1-1-4-4-4-4 Set PointOfReturn to *ToneTermination*.
 - 1-1-4-4-5 ELSEIF the call was abandoned (no Digits (Dialed) parameter was received):

¹The voice mail PIN stored with the HLR is assumed to be concurrent with the PIN stored in the voice mail system.

| | | |
|-------------|--|----|
| 1-1-4-4-5-1 | Set PointOfReturn to <i>ToneTermination</i> . | 1 |
| 1-1-4-4-6 | ELSE (bad second entry of VoiceMailboxPIN or the Digits (Dialed) parameter contains no digits): | 2 |
| | (Retries are possible here, but may pose a security risk.) | 3 |
| | | 4 |
| 1-1-4-4-6-1 | Optionally, include the AnnouncementCode parameter in the AnnouncementList parameter set to an appropriate announcement. | 5 |
| | | 6 |
| | | 7 |
| | | 8 |
| | | 9 |
| 1-1-4-4-6-2 | Include the FeatureResult parameter set to <i>Unsuccessful</i> to indicate unsuccessful feature operation. | 10 |
| | | 11 |
| | | 12 |
| 1-1-4-4-6-3 | Set PointOfReturn to <i>ToneTermination</i> . | 13 |
| 1-1-4-4-7 | ENDIF. | 14 |
| 1-1-4-5 | ELSEIF the call was abandoned (no Digits (Dialed) parameter was received): | 15 |
| | | 16 |
| | | 17 |
| 1-1-4-5-1 | Set PointOfReturn to <i>ToneTermination</i> . | 18 |
| 1-1-4-6 | ELSE (unacceptable VoiceMailboxPIN or the Digits (Dialed) parameter contains no digits): | 19 |
| | (Retries are possible here.) | 20 |
| | | 21 |
| | | 22 |
| 1-1-4-6-1 | Optionally, include the AnnouncementCode parameter in the AnnouncementList parameter set to an appropriate announcement. | 23 |
| | | 24 |
| | | 25 |
| 1-1-4-6-2 | Include the FeatureResult parameter set to <i>Unsuccessful</i> to indicate unsuccessful feature operation. | 26 |
| | | 27 |
| | | 28 |
| 1-1-4-6-3 | Set PointOfReturn to <i>ToneTermination</i> . | 29 |
| 1-1-4-7 | ENDIF. | 30 |
| 1-1-5 | ELSEIF the call was abandoned (no Digits (Dialed) parameter was received): | 31 |
| | | 32 |
| 1-1-5-1 | Set PointOfReturn to <i>ToneTermination</i> . | 33 |
| 1-1-6 | ELSE (incorrect VoiceMailboxPIN entered or the Digits (Dialed) parameter contains no digits): | 34 |
| | (Retries are possible here, but may pose a security risk.) | 35 |
| | | 36 |
| | | 37 |
| 1-1-6-1 | Optionally, include the AnnouncementCode parameter in the AnnouncementList parameter set to an appropriate announcement. | 38 |
| | | 39 |
| | | 40 |
| 1-1-6-2 | Include the FeatureResult parameter set to <i>Unsuccessful</i> to indicate unsuccessful feature operation. | 41 |
| | | 42 |
| | | 43 |
| 1-1-6-3 | Set PointOfReturn to <i>ToneTermination</i> . | 44 |
| 1-1-7 | ENDIF. | 45 |
| 1-2 | ELSE (transaction is not <i>RemoteUserInteraction</i> capable): | 46 |
| | | 47 |
| 1-2-1 | Optionally, include the AnnouncementCode parameter in the AnnouncementList parameter set to an appropriate announcement. | 48 |
| | | 49 |
| | | 50 |
| 1-2-2 | Include the FeatureResult parameter set to <i>Unsuccessful</i> to indicate unsuccessful feature operation. | 51 |
| | | 52 |
| | | 53 |
| 1-2-3 | Set PointOfReturn to <i>ToneTermination</i> . | 54 |
| 1-3 | ENDIF. | 55 |
| 2 | ELSE (VMR VoiceMailboxPIN Registration is not authorized): | 56 |
| | | 57 |
| 2-1 | Optionally, include the AnnouncementCode parameter in the AnnouncementList parameter set to an appropriate announcement. | 58 |
| | | 59 |
| | | 60 |

- 1 2-2 Include the FeatureResult parameter set to *Unsuccessful* to indicate unsuccessful
2 feature operation.
3
4 2-3 Set PointOfReturn to *ToneTermination*.
5 3 ENDIF.
6 4 Return to calling task via the PointOfReturn.
7
8

5.23.2 HLR VMR Invocation

11 Upon request (e.g., via feature code or revertive call), the HLR shall do the following:

- 12 1 IF the VMR invocation is authorized for this MS:
13
14 1-1 IF the voice mailbox is implied by an entered Mobile Directory Number:
15
16 1-1-1 IF the Digits (Dialed) parameter was received:
17
18 1-1-1-1 IF the Digits (Dialed) parameter contains a legitimate Mobile Directory
19 Number with voice mail for the subscriber's MobileIdentificationNumber
20 parameter:
21 1-1-1-1-1 IF the selected mailbox is different than the MIN:
22 1-1-1-1-1-1 Include the VoiceMailboxNumber parameter set to the selected
23 mailbox.
24 1-1-1-1-2 ENDIF.
25
26 1-1-1-2 ELSE (the Digits (Dialed) parameter does not contain a voice mailbox
27 number):
28 1-1-1-2-1 Optionally, include the AnnouncementCode parameter in the
29 AnnouncementList parameter set to an appropriate announcement.
30 1-1-1-2-2 Include the FeatureResult parameter set to *Unsuccessful* to indicate
31 unsuccessful feature operation.
32 1-1-1-2-3 Set PointOfReturn to *ToneTermination*.
33 1-1-1-2-4 Return to the calling task.
34
35 1-1-1-3 ENDIF.
36
37 1-1-2 ENDIF.
38
39 1-2 ELSEIF the voice mailbox is implied by the MobileIdentificationNumber
40 parameter:
41 1-2-1 IF the selected mailbox is different than the MIN:
42 1-2-1-1 Include the VoiceMailboxNumber parameter set to the selected mailbox.
43
44 1-2-2 ENDIF.
45
46 1-3 ELSE (the invocation requires a voice mailbox number):
47 1-3-1 IF the Digits (Dialed) parameter has been received:
48 1-3-1-1 IF the Digits (Dialed) parameter contains a legitimate mailbox number for
49 the subscriber's MIN:
50 1-3-1-1-1 IF the selected mailbox is different than the MIN:
51 1-3-1-1-1-1 Include the VoiceMailboxNumber parameter set to the selected
52 mailbox.
53 1-3-1-1-2 ENDIF.
54
55 1-3-1-2 ELSE (the Digits (Dialed) parameter does not contain a voice mailbox
56 number):
57
58
59
60

| | | |
|-------------|---|----|
| 1-3-1-2-1 | Optionally, include the <code>AnnouncementCode</code> parameter in the <code>AnnouncementList</code> parameter set to an appropriate announcement. | 1 |
| | | 2 |
| 1-3-1-2-2 | Include the <code>FeatureResult</code> parameter set to <i>Unsuccessful</i> to indicate unsuccessful feature operation. | 3 |
| | | 4 |
| 1-3-1-2-3 | Set <code>PointOfReturn</code> to <i>ToneTermination</i> . | 5 |
| | | 6 |
| 1-3-1-2-4 | Return to the calling task. | 7 |
| | | 8 |
| 1-3-1-3 | ENDIF. | 9 |
| 1-3-2 | ENDIF. | 10 |
| | | 11 |
| 1-4 | ENDIF. | 12 |
| | (The voice mailbox is selected at this point). | 13 |
| | | 14 |
| 1-5 | IF <code>VoiceMailboxPIN</code> entry is required to access the voice mailbox: | 15 |
| | | 16 |
| 1-5-1 | IF the <code>VoiceMailboxPIN</code> is contained with the <code>Digits (Dialed)</code> parameter: | 17 |
| | | 18 |
| 1-5-1-1 | IF the received <code>Digits (Dialed)</code> parameter contains the subscriber's <code>VoiceMailboxPIN</code> : | 19 |
| | | 20 |
| 1-5-1-1-1 | Include the <code>VoiceMailboxPIN</code> parameter set to the subscriber's <code>VoiceMailboxPIN</code> . | 21 |
| | | 22 |
| 1-5-1-2 | ELSE (received <code>Digits (Dialed)</code> parameter does not contain the subscriber's <code>VoiceMailboxPIN</code>): | 23 |
| | | 24 |
| 1-5-1-2-1 | Optionally, include the <code>AnnouncementCode</code> parameter in the <code>AnnouncementList</code> parameter set to an appropriate announcement. | 25 |
| | | 26 |
| 1-5-1-2-2 | Include the <code>FeatureResult</code> parameter set to <i>Unsuccessful</i> to indicate unsuccessful feature operation. | 27 |
| | | 28 |
| 1-5-1-2-3 | Set <code>PointOfReturn</code> to <i>ToneTermination</i> . | 29 |
| | | 30 |
| 1-5-1-2-4 | Return to the calling task. | 31 |
| | | 32 |
| 1-5-1-3 | ENDIF. | 33 |
| 1-5-2 | ELSE (the <code>VoiceMailboxPIN</code> is not contained with the <code>Digits (Dialed)</code> parameter, but it is required): | 34 |
| | | 35 |
| 1-5-2-1 | IF the received <code>TransactionCapability</code> parameter indicates that <i>RemoteUserInteraction</i> is possible: | 36 |
| | | 37 |
| 1-5-2-1-1 | Include the <code>AnnouncementCode</code> parameter in the <code>AnnouncementList</code> parameter set to prompt the subscriber to enter a Voice Mailbox PIN. | 38 |
| | | 39 |
| 1-5-2-1-2 | Include the <code>DigitCollectionControl</code> parameter set appropriately. | 40 |
| | | 41 |
| 1-5-2-1-3 | Execute a "HLR Initiating a Remote User Interaction Directive" task (see 4.39.1). | 42 |
| | | 43 |
| 1-5-2-1-4 | IF the received <code>Digits (Dialed)</code> parameter matches the stored <code>VoiceMailboxPIN</code> : | 44 |
| | | 45 |
| 1-5-2-1-4-1 | Include the <code>VoiceMailboxPIN</code> parameter set to the subscriber's <code>VoiceMailboxPIN</code> . | 46 |
| | | 47 |
| 1-5-2-1-5 | ELSEIF the call was abandoned (no <code>Digits (Dialed)</code> parameter was received): | 48 |
| | | 49 |
| 1-5-2-1-5-1 | Include the <code>FeatureResult</code> parameter set to <i>Unsuccessful</i> to indicate unsuccessful feature operation. | 50 |
| | | 51 |
| 1-5-2-1-5-2 | Set <code>PointOfReturn</code> to <i>ToneTermination</i> . | 52 |
| | | 53 |
| 1-5-2-1-5-3 | Return to the calling task. | 54 |
| | | 55 |
| | | 56 |
| | | 57 |
| | | 58 |
| | | 59 |
| | | 60 |

| | | |
|----|-------------|---|
| 1 | 1-5-2-1-6 | ELSE (the call was refused, i.e., the incorrect PIN was entered or the Digits (Dialed) parameter contains no digits): |
| 2 | | (Retries are possible here, but may pose a security risk.) |
| 3 | | |
| 4 | | |
| 5 | 1-5-2-1-6-1 | Optionally, include the AnnouncementCode parameter in the AnnouncementList parameter set to an appropriate announcement. |
| 6 | | |
| 7 | | |
| 8 | | |
| 9 | 1-5-2-1-6-2 | Include the FeatureResult parameter set to <i>Unsuccessful</i> to indicate unsuccessful feature operation. |
| 10 | | |
| 11 | 1-5-2-1-6-3 | Set PointOfReturn to <i>ToneTermination</i> . |
| 12 | 1-5-2-1-6-4 | Return to the calling task. |
| 13 | | |
| 14 | 1-5-2-1-7 | ENDIF. |
| 15 | 1-5-2-2 | ELSE (transaction is not capable of remote interaction): |
| 16 | | |
| 17 | 1-5-2-2-1 | Optionally, include the AnnouncementCode parameter in the AnnouncementList parameter set to an appropriate announcement. |
| 18 | | |
| 19 | 1-5-2-2-2 | Include the FeatureResult parameter set to <i>Unsuccessful</i> to indicate unsuccessful feature operation. |
| 20 | | |
| 21 | | |
| 22 | 1-5-2-2-3 | Set PointOfReturn to <i>ToneTermination</i> . |
| 23 | 1-5-2-2-4 | Return to the calling task. |
| 24 | | |
| 25 | 1-5-2-3 | ENDIF. |
| 26 | 1-5-3 | ENDIF. |
| 27 | 1-6 | ELSE (VoiceMailboxPIN is not required): |
| 28 | | |
| 29 | 1-6-1 | IF VoiceMailboxPIN is allowed to be entered: |
| 30 | | |
| 31 | 1-6-1-1 | IF the received Digits (Dialed) parameter contains the stored VoiceMailboxPIN: |
| 32 | | |
| 33 | 1-6-1-1-1 | Include the VoiceMailboxPIN parameter set to the subscriber's VoiceMailboxPIN. |
| 34 | | |
| 35 | 1-6-1-2 | ELSE (supplied Digits (Dialed) parameter does not contain the VoiceMailboxPIN): |
| 36 | | |
| 37 | | (Retries are possible here, if the remote interactions are possible, but may pose a security risk.) |
| 38 | | |
| 39 | | |
| 40 | 1-6-1-2-1 | Optionally, include the AnnouncementCode parameter in the AnnouncementList parameter set to an appropriate announcement. |
| 41 | | |
| 42 | 1-6-1-2-2 | Include the FeatureResult parameter set to <i>Unsuccessful</i> to indicate unsuccessful feature operation. |
| 43 | | |
| 44 | | |
| 45 | 1-6-1-2-3 | Set PointOfReturn to <i>ToneTermination</i> . |
| 46 | 1-6-1-2-4 | Return to the calling task. |
| 47 | | |
| 48 | 1-6-1-3 | ENDIF. |
| 49 | 1-6-2 | ELSE: |
| 50 | | |
| 51 | 1-6-2-1 | IF the Digits (Dialed) parameter was received AND IF the Digits (Dialed) parameter contains additional digits (presumably a VoiceMailboxPIN): |
| 52 | | |
| 53 | 1-6-2-1-1 | Optionally, include the AnnouncementCode parameter in the AnnouncementList parameter set to an appropriate announcement. |
| 54 | | |
| 55 | 1-6-2-1-2 | Include the FeatureResult parameter set to <i>Unsuccessful</i> to indicate unsuccessful feature operation. |
| 56 | | |
| 57 | | |
| 58 | 1-6-2-1-3 | Set PointOfReturn to <i>ToneTermination</i> . |
| 59 | | |
| 60 | | |

| | | |
|-----------|--|----|
| 1-6-2-1-4 | Return to the calling task. | 1 |
| 1-6-2-2 | ENDIF. | 2 |
| 1-6-3 | ENDIF. | 3 |
| 1-7 | ENDIF. | 4 |
| | (Voice mailbox and password have been selected at this point, if necessary.) | 5 |
| | | 6 |
| 1-8 | IF the MSC hosting the voice mail system is the same as the requesting MSC: | 7 |
| 1-8-1 | Include the ElectronicSerialNumber parameter set to identify the called MS. | 8 |
| 1-8-2 | Include the MobileIdentificationNumber parameter set to identify the called MS. | 9 |
| 1-8-3 | Include the DMH_RedirectionIndicator parameter set to <i>Voice Mail Retrieval</i> .. | 10 |
| 1-8-4 | IF the requesting MSC is capable of at least one MultipleTerminations according to the TransactionCapability parameter received with the FeatureRequest INVOKE or OriginationRequest INVOKE: | 11 |
| 1-8-4-1 | Include the MSCID parameter set to the identity of the Serving MSC. | 12 |
| 1-8-4-2 | Include the ElectronicSerialNumber parameter set to identify the called MS within a LocalTermination parameter within a TerminationList parameter. | 13 |
| 1-8-4-3 | Include the MobileIdentificationNumber parameter set to identify the called MS within a LocalTermination parameter within a TerminationList parameter. | 14 |
| 1-8-4-4 | Include the TerminationTreatment parameter set to <i>VMR</i> within a LocalTermination parameter within a TerminationList parameter. | 15 |
| 1-8-4-5 | Include the FeatureResult parameter set to <i>Successful</i> to indicate successful feature operation. | 16 |
| 1-8-4-6 | Set PointOfReturn to <i>LocalTermination</i> . | 17 |
| 1-8-5 | ELSE (multiple terminations are not allowed, this must be a temporary failure): | 18 |
| 1-8-5-1 | Include the MSCID parameter set to the identity of the Serving MSC. | 19 |
| 1-8-5-2 | Optionally, include the AnnouncementCode parameter in the AnnouncementList parameter set to an appropriate announcement. | 20 |
| 1-8-5-3 | Include the AccessDeniedReason parameter set to an appropriate value. | 21 |
| 1-8-5-4 | Include the FeatureResult parameter set to <i>Unsuccessful</i> to indicate unsuccessful feature operation. | 22 |
| 1-8-5-5 | Set PointOfReturn to <i>ToneTermination</i> . | 23 |
| 1-8-6 | ENDIF. | 24 |
| 1-9 | ELSE (the MSC hosting the voice mail system is a different MSC): | 25 |
| 1-9-1 | Set the message destination to the MSC hosting the voice mail system. | 26 |
| 1-9-2 | Include the TerminationTreatment parameter set to <i>VoiceMailRetrieval</i> . | 27 |
| 1-9-3 | Execute a “HLR Initiating a Routing Request” task (see 4.41.1). | 28 |
| 1-9-4 | IF an AccessDeniedReason parameter is received: | 29 |
| 1-9-4-1 | Optionally, include the AnnouncementCode parameter in the AnnouncementList parameter set to an appropriate announcement. | 30 |
| 1-9-4-2 | Include the FeatureResult parameter set to <i>Unsuccessful</i> to indicate unsuccessful feature operation. | 31 |
| | | 32 |
| | | 33 |
| | | 34 |
| | | 35 |
| | | 36 |
| | | 37 |
| | | 38 |
| | | 39 |
| | | 40 |
| | | 41 |
| | | 42 |
| | | 43 |
| | | 44 |
| | | 45 |
| | | 46 |
| | | 47 |
| | | 48 |
| | | 49 |
| | | 50 |
| | | 51 |
| | | 52 |
| | | 53 |
| | | 54 |
| | | 55 |
| | | 56 |
| | | 57 |
| | | 58 |
| | | 59 |
| | | 60 |

1 1-9-4-3 Set PointOfReturn to *ToneTermination*.

2

3 1-9-5 ELSE (access is allowed):

4 1-9-5-1 Include the ElectronicSerialNumber parameter set to identify the called

5 MS.

6 1-9-5-2 Include the MobileIdentificationNumber parameter set to identify the

7 called MS.

8

9 1-9-5-3 Include the DMH_RedirectionIndicator parameter set to *Voice Mail Retrieval*..

10

11 1-9-5-4 IF the requesting MSC is capable of at least one MultipleTerminations

12 according to the TransactionCapability received with the FeatureRequest

13 INVOKE or OriginationRequest INVOKE:

14 1-9-5-4-1 Include the MSCID parameter set to the identity of the Originating

15 MSC.

16 1-9-5-4-2 Include the DestinationDigits parameter within an

17 IntersystemTermination parameter within a TerminationList

18 parameter set to the contents of the Digits (Destination) parameter

19 received from the RoutingRequest RETURN RESULT.

20 1-9-5-4-3 Include the MSCID parameter set to the identity of the Serving MSC

21 within an IntersystemTermination parameter within a

22 TerminationList parameter.

23 1-9-5-4-4 Include the ElectronicSerialNumber parameter set to identify the

24 called MS within an IntersystemTermination parameter within a

25 TerminationList parameter.

26 1-9-5-4-5 Include the MobileIdentificationNumber parameter set to identify the

27 called MS within an IntersystemTermination parameter within a

28 TerminationList parameter.

29 1-9-5-4-6 Include the MSCIdentificationNumber parameter set to identify the

30 Serving MSC within an IntersystemTermination parameter within a

31 TerminationList parameter.

32 1-9-5-4-7 Include the FeatureResult parameter set to *Successful* to indicate

33 successful feature operation.

34 1-9-5-4-8 Set PointOfReturn to *IntersystemTermination*.

35 1-9-5-5 ELSE (multiple terminations are not allowed):

36 1-9-5-5-1 Include the MSCID parameter set to the identity of the Serving MSC.

37 1-9-5-5-2 Relay the Digits (Destination) parameter received from the

38 RoutingRequest RETURN RESULT.

39 1-9-5-5-3 Include the FeatureResult parameter set to *Successful* to indicate

40 successful feature operation.

41 1-9-5-5-4 Set PointOfReturn to *IntersystemTermination*.

42 1-9-5-6 ENDIF.

43 1-9-6 ENDIF.

44 1-10 ENDIF.

45 2 ELSE (the MS is not authorized)

46 2-1 Optionally, include the AnnouncementCode parameter in the AnnouncementList

47 parameter set to an appropriate announcement.

48 2-2 Include the FeatureResult parameter set to *Unsuccessful* to indicate unsuccessful

49 feature operation.

50

51

52

53

54

55

56

57

58

59

60

- 2-3 Set PointOfReturn to *ToneTermination*.
- 2-4 Return to the calling task.
- 3 ENDIF.
- 4 Return to calling task via the PointOfReturn.

5.23.3 HLR VMR Revertive Call Invocation

Upon request, the HLR shall do the following:

- 1 Execute the “HLR VMR Invocation” task (see 5.23.2).
- 2 IF the FeatureResult parameter has been included:
 - 2-1 Discard the FeatureResult parameter.
- 3 ENDIF.
- 4 Return to the calling task via the PointOfReturn.

5.24 VOICE PRIVACY (VP)

Voice Privacy is controlled by the call processing in the Serving MSC in a manner consistent with *IS-53*. Voice Privacy is authorized with a CallingFeaturesIndicator Feature Mask value in the subscriber’s service profile. Voice Privacy is requested with an indication from the MS. Voice privacy is provided to those authorized MS’s requesting it in system capable of providing the service.

6 COMMON VOICE FEATURE PROCEDURES

6.1 CALL FORWARDING ROUTING

6.1.1 HLR Select Forward-To or Diversion Number Courtesy Call Point of Return

Upon request, the HLR shall do the following:

- 1 IF the selected forward-to number or diversion number indicates voice mail:
(Courtesy call does not apply.)
 - 1-1 Set the PointOfReturn to *ToneTermination*.
- 2 ELSE (directory number is specified):
 - 2-1 Include the Digits (Destination) parameter set to the forward-to number or diversion number.
 - 2-2 Set the PointOfReturn to *PSTNTermination*.
- 3 ENDIF.
- 4 Return to calling task via the PointOfReturn.

6.1.2 HLR Select Forward-To or Diversion Number Point of Return

Upon request, the HLR shall do the following:

- 1 IF the received TransactionCapability parameter has been received AND IF it indicates the system is *termination list capable*:
 - 1-1 IF the selected forward-to number or diversion number indicates voice mail:
 - 1-1-1 IF the voice mailbox is not the MIN of the called subscriber:
 - 1-1-1-1 Include the VoiceMailboxNumber set to the appropriate mailbox.
 - 1-1-2 ENDIF.
 - 1-1-3 IF the system launching the current request is the same as the voice mail system:
 - 1-1-3-1 Set the PointOfReturn to *LocalTermination*.
 - 1-1-3-2 Include the TerminationTreatment parameter set to *VoiceMailDelivery*.
 - 1-1-4 ELSE:
 - 1-1-4-1 Include the TerminationTreatment set to *VoiceMailDelivery*.
 - 1-1-4-2 Execute the “HLR Initiating a Routing Request” task (see 4.41.1).
 - 1-1-4-3 IF Digits (Destination) is received:
 - 1-1-4-3-1 Relay the received Digits (Destination).
 - 1-1-4-3-2 Set the PointOfReturn to *IntersystemTermination*.
 - 1-1-4-4 ELSE (The voice mail box cannot be reached):
 - 1-1-4-4-1 Optionally, include the AnnouncementCode parameter in the AnnouncementList parameter set to an appropriate announcement.

- 1-1-4-4-2 Set the PointOfReturn to *ToneTermination*.
- 1-1-4-5 ENDIF.
- 1-1-5 ENDIF.
- 1-2 ELSE (a directory number is specified):
 - 1-2-1 Include the Digits (Destination) parameter set to the selected forward-to number or diversion number.
 - 1-2-2 Set the PointOfReturn to *PSTNTermination*.
 - 1-3 ENDIF.
- 2 ELSE (the system is not termination list capable):
 - 2-1 IF the selected forward-to number or diversion number indicates voice mail:
 - 2-1-1 Optionally, include the AnnouncementCode parameter in the AnnouncementList parameter set to an appropriate announcement.
 - 2-1-2 Set the PointOfReturn to *ToneTermination*.
 - 2-2 ELSE (a directory number is specified):
 - 2-2-1 Include the Digits (Destination) parameter set to the forward-to number or diversion number.
 - 2-2-2 Set the PointOfReturn to *PSTNTermination*.
 - 2-3 ENDIF.
- 3 ENDIF.
- 4 Return to calling task via the PointOfReturn.

6.2 DIGIT ANALYSIS

6.2.1 Termination Address Expansion

- 1 IF extra digits are included with the feature code string:
 - 1-1 IF TransactionCapability parameter number of terminations is set to at least one:
 - 1-1-1 IF next digit is a pound ('#') digit:
 - 1-1-1-1 Skip over the pound ('#') digit.
 - 1-1-1-2 IF termination address can be expanded into a destination address.
 - 1-1-2-1 Execute the "HLR SPINI Feature Request Invocation" task (see 5.21.4).
 - 1-1-2-2 IF the SPINI invocation *failed*:
 - 1-1-2-2-1 Return to the calling task via the PointOfReturn.
 - 1-1-2-3 ELSE:
 - 1-1-2-3-1 Include DestinationDigits parameter set to the destination address.
 - 1-1-2-3-2 Set PointOfReturn to PSTN Termination.
 - 1-1-2-4 ENDIF.
 - 1-1-1-3 ELSE:
 - 1-1-3-1 Optionally, include the AnnouncementCode parameter in the AnnouncementList parameter set to an appropriate announcement.

1 1-1-3-2 Set PointOfReturn to *ToneTermination*.
2
3 1-1-1-4 ENDIF.
4 1-1-2 ELSE:
5 1-1-2-1 Optionally, include the AnnouncementCode parameter in the
6 AnnouncementList parameter set to an appropriate announcement.
7
8 1-1-2-2 Set PointOfReturn to *ToneTermination*.
9 1-1-3 ENDIF.
10
11 1-2 ELSE:
12 1-2-1 (Ignore the extra digits, cannot do anything with them.)
13 1-2-2 Set PointOfReturn to *ToneTermination*.
14
15 1-3 ENDIF.
16 2 ENDIF.
17 3 Return to the calling task.
18
19
20
21
22
23
24
25
26
27
28
29
30
31
32
33
34
35
36
37
38
39
40
41
42
43
44
45
46
47
48
49
50
51
52
53
54
55
56
57
58
59
60

7 OPERATION TIMER VALUES

The following table provides a summary of the timers used for MAP operations. The timer values specified in this table are default values only and should be optimized for actual operating environments. Some timers are locally defined and are not in this table (e.g., alerting timer, no answer timer, page response timer, maximum interaction timer, interdigit timer).

Table 63 Operation Timer Values

| Timer | Default (sec.) | Started when | Normally stopped when | Action when timer expires |
|--|-------------------|---|--|------------------------------|
| ADT
Authentication Directive Timer | 6 | Authentication-Directive INVOKE is sent. | AuthenticationDirective RETURN RESULT or RETURN ERROR is received. | Execute recovery procedures. |
| ADFT
Authentication Directive Forward Timer | 15 | Authentication-DirectiveForward INVOKE is sent. | AuthenticationDirective-Forward RETURN RESULT or RETURN ERROR is received. | Execute recovery procedures. |
| AFRT
Authentication Failure Report Timer | 6 | Authentication-FailureReport INVOKE is sent. | AuthenticationFailure-Report RETURN RESULT or RETURN ERROR is received. | Execute recovery procedures. |
| ART
Authentication Request Timer | 6 | Authentication-Request INVOKE is sent. | AuthenticationRequest RETURN RESULT or RETURN ERROR is received. | Execute recovery procedures. |
| ASRRT
Authentication Status Report Response Timer | 24 | An authentication operation, that requires an Authentication-StatusReport reply, is sent. | AuthenticationStatus-Report INVOKE is received. | Execute recovery procedures. |
| ASRT
Authentication Status Report Timer | 6 | Authentication-StatusReport INVOKE is sent. | AuthenticationStatus-Report RETURN RESULT or RETURN ERROR is received. | Execute recovery procedures. |
| BDT
Bulk Deregistration Timer | 6 | BulkDeregistration INVOKE is sent. | BulkDeregistration RETURN RESULT or RETURN ERROR is received. | Execute recovery procedures. |
| BSCT
Base Station Challenge Timer | 3
(see Note 1) | BaseStation-Challenge INVOKE is sent. | BaseStationChallenge RETURN RESULT or RETURN ERROR is received. | Execute recovery procedures. |

continued

Table 63 Operation Timer Values (continued)

| Timer | Default (sec.) | Started when | Normally stopped when | Action when timer expires |
|--|-----------------------|---|---|----------------------------------|
| CRT
Count Request Timer | 6 | CountRequest INVOKE is sent. | CountRequest RETURN RESULT or RETURN ERROR is received. | Execute recovery procedures. |
| CTT
Clear Trunk Timer | 4 to 15 | FacilitiesRelease INVOKE is sent. | FacilitiesRelease RETURN RESULT or RETURN ERROR is received. | See Chapter 4 Section 5.2.5.1. |
| FRRT
(see Note 2)
Feature Request Response Timer | 16 | FeatureRequest INVOKE (or a subsequent RemoteUser-InteractionDirective INVOKE) is sent. | FeatureRequest RETURN RESULT, FeatureRequest RETURN ERROR, or a RemoteUser-InteractionDirective INVOKE is received. | Execute recovery procedures. |
| FRT
FlashRequest Timer | 6 | MSC transmits a FlashRequest INVOKE. | FlashRequest RETURN RESULT or RETURN ERROR is received. | See 4.11.7 and 4.20.1. |
| HOT
Handoff Order Timer | 12
(see Note 3) | Serving MSC sends FacilitiesDirective INVOKE or Handoff-Back INVOKE to Target MSC. | FacilitiesDirective or HandoffBack RETURN RESULT or RETURN ERROR is received. | See 4.11.1, 4.16.1, and 4.20.4. |
| HTTRT
Handoff-To-Third Result Timer | 7
(see Note 4) | Serving MSC receives Handoff-To-Third RETURN RESULT. | FacilitiesRelease INVOKE is received. | See 4.20.1. |
| HTTT
Handoff-To-Third Timer | 18
(see Note 3) | HandoffToThird INVOKE is sent | HandoffToThird RETURN RESULT or RETURN ERROR is received. | See 4.20.1. |
| IDT
Information Directive Timer | 6 | InformationDirective INVOKE is sent. | InformationDirective RETURN RESULT or RETURN ERROR is received. | Execute recovery procedures. |
| IFT
Information Forward Timer | 6 | InformationForward INVOKE is sent. | InformationForward RETURN RESULT or RETURN ERROR is received. | Execute recovery procedures. |

continued

Table 63 Operation Timer Values (continued)

| Timer | Default (sec.) | Started when | Normally stopped when | Action when timer expires |
|--|-----------------|--|--|--|
| ISART
Intersystem Answer Response Timer | 78 | Affirmative InterSystemSetup RETURN RESULT is received. | InterSystemAnswer INVOKE is received. | Execute recovery procedures. |
| ISAT
Intersystem Answer Timer | 7 | InterSystemAnswer INVOKE is sent. | InterSystemAnswer RETURN RESULT is received. | Execute recovery procedures. |
| ISPRT
Intersystem Page Request Timer | 13 | InterSystemPage or InterSystemPage2 INVOKE is sent. | InterSystemPage or InterSystemPage2 RETURN RESULT or RETURN ERROR is received. | Execute recovery procedures. |
| ISSRT
Intersystem Setup Timer | 7 | InterSystemSetup INVOKE is sent. | InterSystemSetup RETURN RESULT or RETURN ERROR is received. | Execute recovery procedures. |
| ISSWT
Intersystem Setup Wait Timer | 60 | InterSystemPage2 RETURN RESULT is sent. | InterSystemSetup INVOKE is received. | Execute recovery procedures. |
| LMMRT
Location Measurement Maximum Response Timer | 7 | Serving MSC requests handoff measurements from the Candidate MSC. | Serving MSC receives handoff measurements from Candidate MSC. | See 4.18.1. |
| LRT
Location Request Timer | 16 | LocationRequest INVOKE (or a subsequent RemoteUser-InteractionDirective INVOKE) is sent. | LocationRequest RETURN RESULT, Location Request RETURN ERROR, or a RemoteUserInteraction-Directive INVOKE is received. | Apply appropriate access denial treatment. |
| MAHT
Mobile Access Hunt Timer | 30 (see Note 5) | MAH context is created or extended. | MAH context is closed. | Release MAH context. |
| MAT
Mobile Arrival Timer | 7 (see Note 4) | Target MSC replies affirmatively to Serving MSC handoff request. | Target MSC receives MS on the designated voice channel. | Sees 4.11.3 and 4.16.3. |
| MHOT
Mobile Handoff Order Timer | 7 (see Note 4) | Serving MSC receives affirmative reply from Target MSC to handoff request. | Target MSC indicates to Serving MSC that MS is on channel. | Sees 4.11.1, 4.16.1, and 4.20.4. |
| MSIT
MS Inactive Timer | 6 | MSInactive INVOKE is sent. | MSInactive RETURN RESULT or RETURN ERROR is received. | Execute recovery procedures. |

continued

Table 63 Operation Timer Values (continued)

| Timer | Default (sec.) | Started when | Normally stopped when | Action when timer expires |
|---|-----------------------|---|---|----------------------------------|
| ORT
Origination Request Timer | 16 | OriginationRequest INVOKE (or a subsequent RemoteUser-InteractionDirective INVOKE) is sent. | OriginationRequest RETURN RESULT, OriginationRequest RETURN ERROR, or a RemoteUser-InteractionDirective INVOKE is received. | Execute recovery procedures. |
| PAT
PACA Answer Timer | 18 | PACA is honored. | PACA is answered. | See 5.17.2. |
| PDT
PACA Detection Timer | | PACA is invoked. | MS invoking PACA was detected. | Execute recovery procedures. |
| PFT
PACA Feedback Timer | 15 | PACA is invoked. | PACA is honored or abandoned. | See 5.17.2. |
| QDT
Qualification Directive Timer | 6 | Qualification-Directive INVOKE is sent. | QualificationDirective RETURN RESULT or RETURN ERROR is received. | Execute recovery procedures. |
| QRT
Qualification Request Timer | 6 | Qualification-Request INVOKE is sent. | QualificationRequest RETURN RESULT or RETURN ERROR is received. | Execute recovery procedures. |
| RANDRT
Random Variable Request Timer | 6 | RandomVariable-Request INVOKE is sent. | RandomVariable-Request RETURN RESULT or RETURN ERROR is received. | Execute recovery procedures. |
| RCT
Registration Cancellation Timer | 6 | Registration-Cancellation INVOKE is sent. | RegistrationCancellation RETURN RESULT or RETURN ERROR is received. | Execute recovery procedures. |
| RDRT
Redirection Request Timer | 22 | RedirectionRequest INVOKE is sent. | RedirectionRequest RETURN RESULT or RETURN ERROR is received. | Execute recovery procedures. |
| RDT
Redirection Directive Timer | 6 | RedirectionDirective INVOKE is sent. | RedirectionDirective RETURN RESULT or RETURN ERROR is received. | Execute recovery procedures. |
| RFCT
(See note 2) | | | | |
| RNT
Registration Notification Timer | 12 | Registration-Notification INVOKE is sent. | RegistrationNotification RETURN RESULT or RETURN ERROR is received. | Execute recovery procedures. |
| RRT | 10 | RoutingRequest INVOKE is sent. | RoutingRequest RETURN RESULT or | Execute recovery |

| | | | | |
|-----------------------|--|--|---------------------------|-------------|
| Routing Request Timer | | | RETURN ERROR is received. | procedures. |
|-----------------------|--|--|---------------------------|-------------|

continued

Table 63 Operation Timer Values (continued)

| Timer | Default (sec.) | Started when | Normally stopped when | Action when timer expires |
|--|---|--|--|------------------------------|
| RUDT
Remote User Interaction Directive Response Timer | 6 + Digit Collection Control Maximum Interaction Time | RemoteUser-InteractionDirective INVOKE is sent. | RemoteUser-InteractionDirective RETURN RESULT or RETURN ERROR is received. | Execute recovery procedures. |
| SADT
Short Message Air Delivery Timer | 18
(see Note 6) | A short message is sent over the air interface. | Response is received. | Execute recovery procedures. |
| SAOT
Short Message Air Origination Timer | 24
(see Note 7) | A short message is sent over the air interface. | Response is received. | Execute recovery procedures. |
| SBT
SMS Delivery Backward Timer | 18
(see Note 7) | SMSDelivery-Backward is sent toward the Anchor MSC. | Response is received. | Execute recovery procedures. |
| SFT
SMS Delivery Forward Timer | 24
(see Note 6) | SMSDelivery-Forward is sent toward the Serving MSC. | Response is received. | Execute recovery procedures. |
| SMT _{network}
Short Message Delivery Timer | 6
(see Note 7) | SMSDelivery-PointToPoint is sent to a network destination. | Response is received. | Execute recovery procedures. |
| SMT _{mobile}
Short Message Delivery Timer | 45
(see Note 6) | SMSDelivery-PointToPoint is sent to an MS-based SME (even over a network). | Response is received. | Execute recovery procedures. |
| SNT
SMS Notification Timer | 6 | SMSNotification INVOKE is sent. | Response is received. | Execute recovery procedures. |
| SRT
SMS Request Timer | 6 | SMSRequest INVOKE is sent. | Response is received. | Execute recovery procedures. |

continued

1
2
3
4
5
6
7
8
9
10
11
12
13
14
15
16
17
18
19
20
21
22
23
24
25
26
27
28
29
30
31
32
33
34
35
36
37
38
39
40
41
42
43
44
45
46
47
48
49
50
51
52
53
54
55
56
57
58
59
60

Table 63 Operation Timer Values (concluded)

| Timer | Default (sec.) | Started when | Normally stopped when | Action when timer expires |
|---|-----------------------|---|---|--|
| THTTT
Tandem
Handoff-To-Third
Timer | 15
(see
Note 3) | Tandem MSC
transits a Handoff-
ToThird INVOKE. | HandoffToThird
RETURN RESULT or
RETURN ERROR is
received. | See 4.11.3. |
| TLDNAT
TLDN
Association
Timer | 20 | A TLDN is assigned
for call delivery. | A call using TLDN is
received | Free TLDN
and discard
associated
information. |
| TTNRT
Transfer To
Number Request
Timer | 16 | TransferToNumber-
Request INVOKE is
sent. | TransferToNumber-
Request RETURN
RESULT or RETURN
ERROR is received. | Execute
recovery
procedures. |
| URDDT
Unreliable
Roamer Data
Directive Timer | 6 | UnreliableRoamer-
DataDirective
INVOKE is sent. | UnreliableRoamerData-
Directive RETURN
RESULT or RETURN
ERROR is received. | Execute
recovery
procedures. |
| URT
Unsolicited
Response Timer | 6 | Unsolicited-
Response INVOKE
is sent. | UnsolicitedResponse
RETURN RESULT or
RETURN ERROR is
received. | Execute
recovery
procedures. |

Note 1: The MS starts a 5 second timer when it issues the Base Station Challenge order. If a response is not received within that period, the SSD update task is abandoned by the MS.

Note 2: The FRRT was named RFCT prior to *IS-41-C*.

Note 3: HTTT>THTTT>HOT.

Note 4: MAT>HTTRT>MHOT.

Note 5: MAHT>No Answer Time + FRRT.

Note 6: for messages to an MS-based SME: SMT_{mobile}>SFT>SADT.

Note 7: for messages to an entity other than an MS-based SME:
SAOT>SBT>SMT_{network}.

A ANNE A PROCEDURES FOR RANDC VERIFICATION

This annex is informative and is not considered part of this Standard.

This annex describes an algorithm for verifying the value of RANDC received from an MS. The algorithm used to verify RANDC is internal to an MSC and, as such, it does not constitute an intersystem operation.

When an MSC receives RANDC(*ms*), the RANDC value reported by an MS, it shall perform the following:

- 1 IF the value of RANDC(*ms*) equals *current* RANDC¹:
 - 1-1 Return to calling task, indicating that RANDC(*ms*) is valid and that the Random Number is *current* RAND.
- 2 ELSEIF the value of RANDC(*ms*) equals *pending* RANDC:
 - 2-1 Return to calling task, indicating that RANDC(*ms*) is valid and that the Random Number is *pending* RAND.
- 3 ELSEIF the value of RANDC(*ms*) equals ZERO:
 - 3-1 Return to calling task, indicating that RANDC(*ms*) is valid and that the Random Number is ZERO.
- 4 ELSE:
 - 4-1 Return to calling task, indicating that RANDC(*ms*) is invalid.
- 1 ENDIF.

¹RAND(*n*) is the random number currently transmitted by the MSC in the OMT of the serving cell. RAND(*n-1*) is the random number transmitted in the OMT of the serving cell immediately prior to RAND(*n*). RANDC is the eight most significant bits of RAND.

B ANNE B PROCEDURES FOR SSD MANAGEMENT AT AC

This annex is informative and is not considered part of this Standard.

This annex describes an algorithm for managing updates to the SharedSecretData (SSD) at the AC. The algorithm used to manage updates is internal to an AC and, as such, it does not constitute an intersystem operation.

When an AC initiates updating of an MS's SSD, it performs the following:

- 1 A new value of SSD is calculated and is stored in the AC's database as the *pending* Shared Secret Data, *pending* SSD; the current value of the Shared Secret Data, *current* SSD, is also retained.
- 2 IF AUTHR(*ms*), an Authentication Result from the MS, is received through an AuthenticationRequest INVOKE:
 - 2-1 Compute *current* AUTHR using the value of *current* SSD.
 - 2-2 IF *current* SSD is not equal to *pending* SSD:
 - 2-2-1 Compute *pending* AUTHR using the value of *pending* SSD.
 - 2-3 ENDIF.
 - 2-4 IF AUTHR(*ms*) equals *current* AUTHR:
 - 2-4-1 Return to calling task, indicating that authentication was successful.
 - 2-5 ELSEIF *current* SSD is not equal to *pending* SSD and AUTHR(*ms*) equals *pending* AUTHR:
 - 2-5-1 Discard *current* SSD.
 - 2-5-2 Store the value of *pending* SSD as the current value.
 - 2-5-3 Return to calling task, indicating that authentication was successful.
 - 2-6 ELSE:
 - 2-6-1 Return to calling task, indicating that authentication was not successful.
 - 2-7 ENDIF.
 - 3 ENDIF.
 - 4 IF a BaseStationChallenge INVOKE is received:
 - 4-1 Compute an Authentication Result (AUTHBS) using *pending* SSD and the Random Number (RANDBS) received in the BaseStationChallenge INVOKE.
 - 4-2 Return to calling task.
 - 5 ENDIF.
 - 6 IF an AuthenticationStatusReport INVOKE is received indicating that SSD updating was successful:
 - 6-1 Discard *current* SSD.
 - 6-2 Store the value of *pending* SSD as the current value.
 - 6-3 Return to calling task.
 - 7 ENDIF.
 - 8 IF an AuthenticationStatusReport INVOKE is received indicating that SSD updating was not successful:

- 8-1 Discard *pending* SSD.
- 8-2 Store *current* SSD in *pending* SSD.
- 9 ENDIF.
- 10 Return to calling task.

1
2
3
4
5
6
7
8
9
10
11
12
13
14
15
16
17
18
19
20
21
22
23
24
25
26
27
28
29
30
31
32
33
34
35
36
37
38
39
40
41
42
43
44
45
46
47
48
49
50
51
52
53
54
55
56
57
58
59
60

C ANNE C AUTHENTICATION RESPONSE VERIFICATION

This annex is informative and is not considered part of this Standard.

This annex describes algorithms for verifying authentication responses at the AC and the VLR (when SSD is shared). These algorithms are used to verify responses and are internal to the AC and VLR, and as such, do not constitute intersystem operations.

T /= **T**

When an AC/HLR detects that its calculated value of AUTHR using the *current* SSD or *pending* SSD (see Annex B) is not equal to the value received from the MS, then:

- 1 Optionally perform Unique Challenge.
- 2 IF the Unique Challenge is not performed OR IF (AuthenticationResponseUnique (AUTHU) /= AUTHU?):
 - 2-1 Deny or allow service according to the authentication procedures of the service provider.
- 3 ENDIF.

When the VLR (if SSD is shared with the current serving system) detects that its calculated value of AUTHR is not equal to the value received from the MS, then:

- 1 IF the MS is marked *pending* SSD update:
 - 1-1 Forward AuthenticationRequest INVOKE to the AC/HLR.
- 2 ELSE:
 - 2-1 Send the appropriate Security Status Report to the AC/HLR.
 - 2-2 Provide call treatment as specified in the RETURN RESULT.
- 3 ENDIF.

(Note: if access is denied, the HLR can optionally take additional protective steps; such as, instructing the VLR to change the authorization period of the mobile)

T **T**

When an AC/HLR detects that its calculated value of AuthenticationResponseUnique (AUTHU) using *current* SSD or *pending* SSD (see Annex B) is not equal to the value received from the MS, then deny or allow service according to the authentication procedures of the service provider at the AC/HLR.

When the MSC detects that its value of AUTHU is not equal to the value received from the MS, then:

- 1 Send the appropriate AuthenticationStatusReport INVOKE to the AC/HLR.
- 2 Provide call treatment as specified in the RETURN RESULT. IF the Unique Challenge was performed due to an SSD update, the AC/HLR may decide to perform an SSD update when the next transaction occurs.

(Note: if access is denied, the HLR can optionally take additional protective steps; such as, instructing the VLR to change the authorization period of the mobile)

T T

When an SSD update failure occurs, the MS shall notify the MSC. (e.g., the MS indicates an SSD update failure in the SSD update Confirmation/ACK, according to *TDMA*.) The MSC shall send the AC/HLR a failure indicator in the AuthenticationStatusReport INVOKE. Authentication procedures at the AC/HLR may result in one of the following actions:

- 1 Attempt to update the SSD at the MS.
- 2 Maintain the old SSD at the AC/HLR and allow service for the MS at the Visited Serving System.
- 3 Maintain the old SSD at the AC/HLR and deny service for the MS at the Visited Serving System.

1
2
3
4
5
6
7
8
9
10
11
12
13
14
15
16
17
18
19
20
21
22
23
24
25
26
27
28
29
30
31
32
33
34
35
36
37
38
39
40
41
42
43
44
45
46
47
48
49
50
51
52
53
54
55
56
57
58
59
60

D ANNE D SMS AIR INTERFACE DELIVERY POINT-TO-POINT

This annex is informative and is not considered part of this Standard.

The following tables describe the parameters used in the illustrative SMD-REQUEST, SMD-ACK, and SMD-NAK messages. These messages must be converted into the appropriate actual air interface messages. It is further assumed that a given message transaction can be correlated across the air interface, so the address parameters are not necessary in the responses.

Table 64 SMD-REQUEST Parameters

| SMD-REQUEST Parameters | | Timer SADT or SAOT | |
|-------------------------------|------|--------------------|--|
| Field | Type | Notes | |
| Contents | | | |
| ElectronicSerialNumber | M | a | |
| MobileIdentificationNumber | M | a | |
| BearerData | M | | |
| TeleserviceIdentifier | O | b | |
| DestinationAddress | O | c, d | |
| OriginalDestinationAddress | O | d | |
| OriginalDestinationSubaddress | O | e | |
| OriginalOriginatingAddress | O | f, g | |
| OriginalOriginatingSubaddress | O | e | |

Notes:

- a. Include to identify the MS on the air interface.
- b. Include on air interfaces that support more than one teleservice.
- c. Include if not carried by the underlying data transport. May require an interconnection agreement to facilitate interworking between network types.
- d. Include if different than the destination address (MobileIdentificationNumber, SMS_DestinationAddress or underlying data transport destination address).
- e. Include if applicable.
- f. Include if different than the originating address (SMS_OriginatingAddress or underlying data transport originating address).
- g. The Originating Address is assumed to be the MS or the Anchor MSC initiating the message.

Table 65 SMD-ACK Parameters

| SMD-ACK Parameters | | | |
|---------------------------|--|-------------|--------------|
| Field | | Type | Notes |
| Contents | | | |
| BearerData | | O | a |

Notes:

- a. Include if applicable.

Table 66 SMD-NAK Parameters

| SMD-NAK Parameters | | | |
|---------------------------|--|-------------|--------------|
| Field | | Type | Notes |
| Contents | | | |
| CauseCode | | M | |

Notes:

The following table reflects a mapping of the SMD-REQUEST parameters with various air interfaces.

1
2
3
4
5
6
7
8
9
10
11
12
13
14
15
16
17
18
19
20
21
22
23
24
25
26
27
28
29
30
31
32
33
34
35
36
37
38
39
40
41
42
43
44
45
46
47
48
49
50
51
52
53
54
55
56
57
58
59
60

Table 67 Mapping of Air Interface Parameters to SMD-REQUEST SMS-ACK and SMD-NAK Parameters

| Parameter Mapping | | | |
|---|----------------------------------|--|---|
| SMD-REQUEST
SMD-ACK or
SMD-NAK | A
Equivalent | A
Equivalent | A
Equivalent |
| Electronic-SerialNumber | carried in lower protocol layers | | |
| Mobile-Identification-Number | carried in lower protocol layers | | |
| BearerData | | SMS Point-to-Point /
Bearer Data | R-Data/
R-Data Unit |
| Teleservice-Identifier | Not applicable | SMS Point-to-Point /
Teleservice ID | R-Data/
Higher Layer Protocol ID |
| Destination-Address | Not applicable | SMS Point-to-Point /
Destination Address | R-Data/
User Destination Address |
| Destination-Subaddress | Not applicable | SMS Point-to-Point /
Destination Subaddress | R-Data/
User Destination
Subaddress |
| Originating-Address | Not applicable | SMS Point-to-Point /
Originating Address | R-Data/
User Originating Address |
| Originating-Subaddress | Not applicable | SMS Point-to-Point /
Originating Subaddress | R-Data/
User Originating
Subaddress |
| CauseCode | Not applicable | SMS Point-to-Point /
Cause Code | R-DataReject/
R-Cause |

D.1 MSC INITIATING SMD-REQUEST TOWARD AN MS-BASED SME

Upon request to send an SMS point-to-point message across the air interface, the MSC shall do the following:

- 1 Set the underlying transport destination address to the message destination (the MIN of the addressed MS).
- 2 IF the message destination is not the same as the MobileIdentificationNumber parameter:
 - 2-1 Include the DestinationAddress parameter set to the destination address.
- 3 ENDIF.
- 4 IF the original message destination is not the same as the destination address:
 - 4-1 Include the OriginalDestinationAddress parameter set to the original destination address.
- 5 ENDIF.
- 6 IF the original message originating is not the same as the originating address:
 - 6-1 Include the OriginalOriginatingAddress parameter set to the original originating address.

- 7 ENDIF. 1
- 8 IF the OriginalDestinationSubaddress is supplied: 2
- 8-1 Include the OriginalDestinationSubaddress parameter. 3
- 9 ENDIF. 4
- 10 IF the OriginalOriginationSubaddress is supplied: 5
- 10-1 Include the OriginalOriginationSubaddress parameter. 6
- 11 ENDIF. 7
- 12 Set the TeleserviceIdentifier to the SMS_TeleserviceIdentifier parameter. 8
- 13 Set the BearerData to the SMS_BearerData parameter. 9
- 14 IF radio contact cannot be established with the MS: 10
- 14-1 Include the SMS_CauseCode parameter indicating *No response to page*. 11
- 14-2 Return to calling task. 12
- 15 ENDIF. 13
- 16 Send a SMD-REQUEST toward the indicated MS. 14
- 17 Start the Short Message Air Delivery Timer (SADT). 15
- 18 WAIT for an SMD-ACK or SMD-NAK response: 16
- 19 WHEN an SMD-ACK is received: 17
- 19-1 Stop the timer (SADT). 18
- 19-2 IF the message can be processed: 19
- 19-2-1 Relay all received parameters. 20
- 19-3 ELSE (the message cannot be processed): 21
- 19-3-1 Include SMS_CauseCode parameter indicating *Other radio interface problem*. 22
- 19-4 ENDIF. 23
- 20 WHEN an SMD-NAK is received: 24
- 20-1 Stop the timer (SADT). 25
- 20-2 IF the message can be processed: 26
- 20-2-1 Relay all received parameters. 27
- 20-3 ELSE (the message cannot be processed): 28
- 20-3-1 Include SMS_CauseCode parameter indicating *Other radio interface problem*. 29
- 20-4 ENDIF. 30
- 21 WHEN the timer (SADT) expires: 31
- 21-1 Include the SMS_CauseCode parameter indicating *No acknowledgment*. 32
- 22 ENDWAIT. 33
- 23 Return to the calling task with the included or relayed parameters. 34

D.2 MS-BASED SME RECEIVING AN SMD-REQUEST

Upon receipt of an air interface SMD-REQUEST, the MS-based SME shall do the following:

- 1 IF the Destination Address (the MobileIdentificationNumber or the ElectronicSerialNumber parameters) addresses this MS:

- 1 1-1 IF the SMS_DestinationAddress parameter is received:
2
3 1-1-1 Set the destination address with the address in the received
4 SMS_DestinationAddress parameter.
5 1-2 ELSE:
6 1-2-1 Set the destination address to the MobileIdentificationNumber.
7
8 1-3 ENDIF.
9 1-4 IF the SMS_OriginalDestinationAddress parameter is received:
10 1-4-1 Set the original destination address with the address in the received
11 SMS_OriginalDestinationAddress parameter.
12 1-5 ELSE:
13 1-5-1 Set the original destination address with the MIN.
14 1-6 ENDIF.
15 1-7 IF the SMS_OriginatingAddress parameter is received:
16 1-7-1 Set the originating address with received SMS_OriginatingAddress.
17 1-8 ELSE:
18 1-8-1 Set the originating address to the Serving MSC.
19 1-9 ENDIF.
20 1-10 IF the SMS_OriginalOriginatingAddress parameter is received:
21 1-10-1 Set the original originating address with the address in the received
22 SMS_OriginalOriginatingAddress parameter.
23 1-11 ELSE:
24 1-11-1 Set the original originating address with the originating address.
25 1-12 ENDIF.
26 1-13 IF the OriginalDestinationSubaddress is received:
27 1-13-1 Set the original destination subaddress to the OriginalDestinationSubaddress.
28 1-14 ENDIF.
29 1-15 IF the OriginalOriginationSubaddress is supplied:
30 1-15-1 Set the original origination subaddress to the OriginalOriginationSubaddress.
31 1-16 ENDIF.
32 1-17 IF the original destination address is not served by this SME:
33 1-17-1 Include the SMS_CauseCode parameter indicating *Address translation failure*.
34 1-17-2 Send a negative acknowledgment (SMD-NAK).
35 1-18 ELSEIF the teleservice indicated by the TeleserviceIdentifier is unknown or is not
36 supported:
37 1-18-1 Include the SMS_CauseCode parameter indicating *Invalid Teleservice ID*.
38 1-18-2 Send a negative acknowledgment (SMD-NAK).
39 1-19 ELSEIF the MS has a resource shortage:
40 1-19-1 Include the SMS_CauseCode parameter indicating *Destination resource
41 shortage*.
42 1-19-2 Send a negative acknowledgment (SMD-NAK).
43 1-20 ELSEIF the SMS_OriginalDestinationSubaddress parameter is not supported:
44 1-20-1 Include the SMS_CauseCode parameter indicating *Address translation failure*.

- 1-20-2 Send a negative acknowledgment (SMD-NAK).
- 1-21 ELSE:
- 1-21-1 Process the message with the indicated teleservice.
- 1-21-2 Send a positive acknowledgment (SMD-ACK) or negative acknowledgment (SMD-NAK) as requested by the teleservice.
- 1-22 ENDIF.
- 2 ELSE:
- 2-1 Discard the message.
- 3 ENDIF.

D.3 MSC RECEIVING AN UNEXPECTED SMD-ACK OR SMD-NAK

Upon receipt of an unexpected air interface SMD-ACK or SMD-NAK, the Serving MSC shall do the following:

- 1 Record or report the error according to internal procedures.
- 2 Discard the message.

D.4 MS-BASED SME INITIATING SMD-REQUEST TOWARD AN MSC

Upon request to send an SMS point-to-point message across the air interface, the MS-based SME shall do the following:

- 1 IF the message destination is not the same as the Anchor MSC (i.e., the message is routed through an intervening SMS router or Tandem MSC):
- 1-1 Include the SMS_DestinationAddress parameter set to the destination address.
- 2 ENDIF.
- 3 IF the original message destination is not the same as the destination address:
- 3-1 Include the SMS_OriginalDestinationAddress parameter set to the original destination address.
- 4 ENDIF.
- 5 Set the underlying transport originating address to the MIN of this MS.
- 6 IF the original originating address is different than the MIN of this MS (i.e., more than one address is supported by the MS):
- 6-1 Include the SMS_OriginalOriginatingAddress parameter set to the original originating address.
- 7 ENDIF.
- (The originating address and the original originating address should be the same for an MS-based SME originated message.)
- 8 IF the OriginalDestinationSubaddress is supplied:
- 8-1 Include the OriginalDestinationSubaddress parameter.
- 9 ENDIF.
- 10 IF the OriginalOriginationSubaddress is supplied:
- 10-1 Include the OriginalOriginationSubaddress parameter.

- 1 11 ENDIF.
- 2
- 3 12 Send a SMD-REQUEST toward the Serving MSC.
- 4 13 Start the Short Message Air Origination Timer (SAOT).
- 5 14 WAIT for an SMD-ACK or SMD-NAK response:
- 6
- 7 15 WHEN an SMD-ACK is received:
- 8 15-1 Stop the timer (SAOT).
- 9 15-2 IF the message is well formed:
- 10 15-2-1 Relay all received parameters.
- 11 15-3 ELSE:
- 12 15-3-1 Include SMS_CauseCode parameter indicating *Other radio interface problem*.
- 13 15-4 ENDIF.
- 14
- 15 16 WHEN an SMD-NAK is received:
- 16 16-1 Stop the timer (SAOT).
- 17 16-2 IF the message is well formed:
- 18 16-2-1 Relay all received parameters.
- 19 16-3 ELSE:
- 20 16-3-1 Include SMS_CauseCode parameter indicating *Other radio interface problem*.
- 21 16-4 ENDIF.
- 22
- 23 17 WHEN the timer (SAOT) expires:
- 24 17-1 Include SMS_CauseCode parameter indicating *Other radio interface problem*.
- 25 18 ENDWAIT.
- 26
- 27 19 Return to the calling task with the included or relayed parameters.
- 28
- 29
- 30
- 31
- 32

33 **D.5 SERVING MSC RECEIVING AN SMD-REQUEST**

34

35

36 Upon receipt of an air interface SMD-REQUEST from an MS-based SME, the Serving

37 MSC shall do the following:

- 38 1 IF the DestinationAddress parameter is received:
- 39 1-1 Set the destination address with the address in the received DestinationAddress
- 40 parameter.
- 41 2 ELSE:
- 42 2-1 Set the destination address to the address of the Anchor MSC.
- 43 3 ENDIF.
- 44 4 IF the OriginalDestinationAddress parameter is received:
- 45 4-1 Set the original destination address with the address in the received
- 46 OriginalDestinationAddress parameter.
- 47 5 ELSE:
- 48 5-1 Set the original destination address with the destination address.
- 49 6 ENDIF.
- 50 7 Set the originating address to the originating MIN.
- 51 8 IF the OriginalOriginatingAddress parameter is received:
- 52
- 53
- 54
- 55
- 56
- 57
- 58
- 59
- 60

- 8-1 Set the original originating address with the address in the received OriginalOriginatingAddress parameter. 1
2
- 9 ELSE: 3
4
- 9-1 Set the original originating address with the originating address. 5
6
- 10 ENDIF. 7
- 11 IF the OriginalDestinationSubaddress parameter is received: 8
- 11-1 Set the original destination subaddress to the OriginalDestinationSubaddress parameter. 9
10
11
- 12 ENDIF. 12
- 13 IF the OriginalOriginationSubaddress parameter is supplied: 13
- 13-1 Set the original origination subaddress to the OriginalOriginationSubaddress parameter. 14
15
16
- 14 ENDIF. 17
- 15 IF the MSC is the Anchor MSC for the indicated MS: 18
- 15-1 Execute the “Anchor MSC Initiating SMS Delivery Point-To-Point” task (see 4.46.5). 19
20
21
- 16 ELSE (the MSC is the Serving MSC): 22
- 16-1 Set the underlying data transport destination address to the Anchor MSC or the next MSC in the handoff chain. 23
24
25
- 16-2 Include the InterMSCCircuitID parameter set to the trunk used in the direction toward the Anchor MSC. 26
27
- 16-3 Execute the “MSC Initiating SMS Delivery Backward” task (see 4.44.1). 28
29
- 17 ENDIF. 30
- (Get here after the message has been relayed and responded to.) 31
32
- 18 IF the MS is still being served: 33
- 18-1 IF the request was *accepted*: 34
- 18-1-1 Relay the indicated SMS_BearerData. 35
36
- 18-1-2 Send an SMD-ACK to the MS based SME. 37
- 18-2 ELSE (the request was *denied*): 38
- 18-2-1 Relay the indicated SMS_CauseCode. 39
40
- 18-2-2 Send an SMD-NAK to the MS based SME. 41
42
- 18-3 ENDIF. 43
- 19 ELSE (the MS is no longer being served): 44
- 19-1 Discard the message. 45
46
- 20 ENDIF. 47
- 21 Return to calling task . 48
49
50

D.6 MS-BASED SME RECEIVING AN UNEXPECTED SMD-ACK OR SMD-NAK 51 52

Upon receipt of an unexpected Air Interface SMD-ACK or SMD-NAK, the MS-based SME shall do the following: 55
56

- 1 Record or report the error according to internal procedures. 57
58
59
60

1
2
3
4
5
6
7
8
9
10
11
12
13
14
15
16
17
18
19
20
21
22
23
24
25
26
27
28
29
30
31
32
33
34
35
36
37
38
39
40
41
42
43
44
45
46
47
48
49
50
51
52
53
54
55
56
57
58
59
60

2 Discard the message.

E ANNE E GLOBAL SERVICE LOGIC

This annex is informative and is not considered part of this Standard.

This annex describes one of several possible methodologies that may be used to describe the call processing and intersystem signaling procedures for cellular features and services.

E.1 INTRODUCTION

This Standard uses intelligent network concepts, although not following any other standard precisely. The basic call processing is described in Section 3. This uses the basic operations to communicate with other functional entities as described in Section 4. Section 5 describes how features interact with the basic operations. Sections 3, 4, 5, and 6 use pseudo code to describe the various procedures.

The intent of this section is to introduce the interaction between different procedures graphically. This is to act as a graphical table of contents for the rest of the document. Each graphic is a Global Service Logic (GSL) that traces a set of decisions to implement a set of services. The GSL usually begins with a Point of Initiation (PofI) or trigger point and it ends with a Point of Return (PofR). The PofI and PofR interact with the basic call processing. The GSL, in general, is not necessarily location or functional entity specific (i.e., the logic may be performed by an MSC, a VLR, an HLR, or some combination thereof). However, to be practical, the logic for each GSL is drawn to be primarily located in a single functional entity. This is to reflect the procedures of this Standard.

Part of each GSL is one or more Service Specific Logic (SSL). This implements the logic or series of decisions for one aspect of a given feature or service. The SSL is shown again as being on a single functional entity, although it can invoke operations to extend its functionality to other functional entities. A given SSL may result in any number of results or Points of Return.

Some of the SSLs are exploded out into another GSL diagram. These GSL begin with a Point of Detection (PofD) rather than a Point of Initiation (PofI). This allows a second GSL to be provided to shown more detail than can be shown on a single diagram.

Only the GSLs to support the features in *IS-53* have been included in this Standard.

E.2 GSL DIAGRAM CONVENTIONS

The Global Service Logic (GSL) diagrams presented in this document use the diagrammatic conventions in the next figure to illustrate the overall decision processes for services and features.

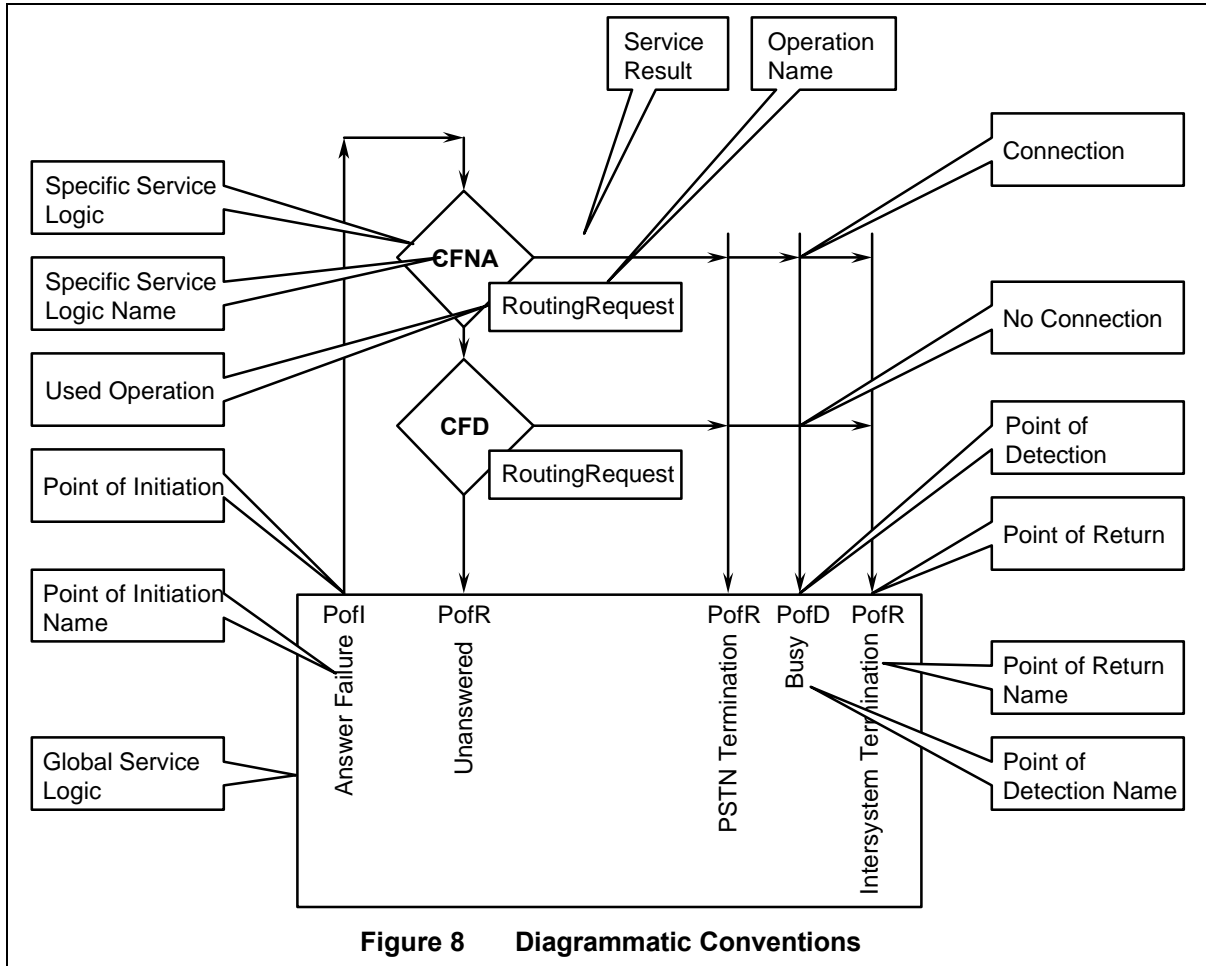

Figure 8 Diagrammatic Conventions

E.3 GSLS

The following are individual GSL diagrams.

E.3.1 Call Origination GSL

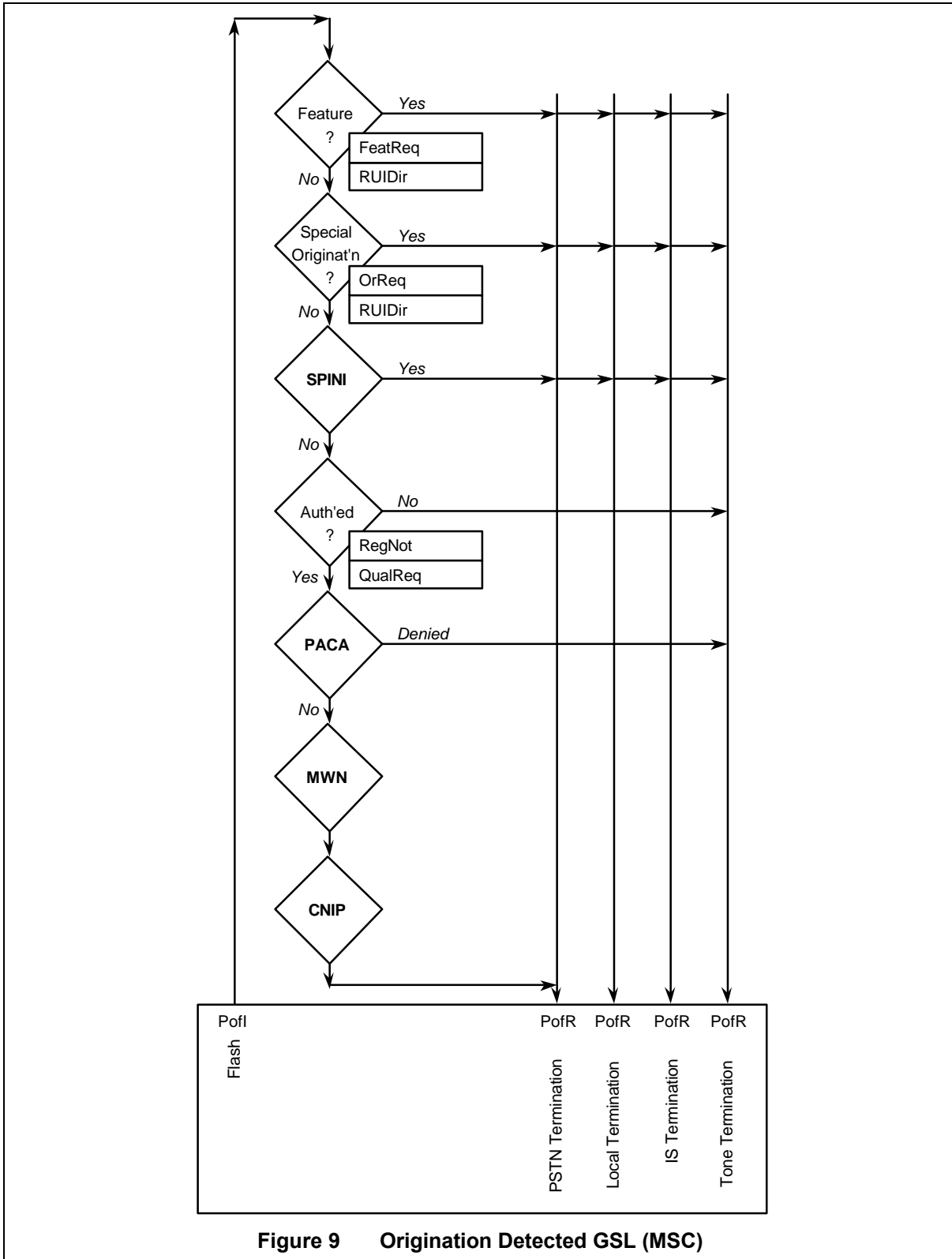

Figure 9 Origination Detected GSL (MSC)

1
2
3
4
5
6
7
8
9
10
11
12
13
14
15
16
17
18
19
20
21
22
23
24
25
26
27
28
29
30
31
32
33
34
35
36
37
38
39
40
41
42
43
44
45
46
47
48
49
50
51
52
53
54
55
56
57
58
59
60

Table 68 Origination Detected GSL (MSC)

| Symbol Name | Main Task Name | Ref. | Uses Task Name | Ref. |
|------------------------------|----------------------------------|----------------|--|--------|
| Origination Pofl | Idle Mobile Origination | 3.2.1 | | |
| Feature SSL | MSC Analyze Mobile Dialed Number | E.3.3
3.2.3 | MSC Detecting Feature Request | 4.14.1 |
| | | | MSC Remote User Interaction | 4.39.2 |
| Special Origination SSL | MSC Analyze Mobile Dialed Number | 3.2.3 | MSC Initiation of Origination Request | 4.31.1 |
| | | | MSC Remote User Interaction | 4.39.2 |
| SPINI SSL | MSC Analyze Mobile Dialed Number | 3.2.3 | MSC SPINI Originating Call Invocation | 5.21.3 |
| Authorized SSL | MSC Analyze Mobile Dialed Number | 3.2.3 | MSC Initiating MS Registration | 5.61 |
| | | | MSC Initiation of Qualification Request | 4.42.1 |
| PACA SSL | MSC Analyze Mobile Dialed Number | 3.2.3 | MSC PACA Call Origination Invocation | 5.17.2 |
| MWN SSL | Idle Mobile Origination | 3.2.1 | MSC MWN Call Origination Invocation | 5.13.7 |
| CNIP SSL | Idle Mobile Origination | 3.2.1 | MSC CNIP Call Origination Invocation | 9.8.3 |
| ToneTermination PofR | Idle Mobile Origination | 3.2.1 | Apply Busy Treatment | 3.4.4 |
| | | | Apply Access Denial Treatment | 3.4.5 |
| | | | Play All Announcements in the AnnouncementList | 3.2.5 |
| PSTNTermination PofR | Idle Mobile Origination | 3.2.1 | MSC Routing Points of Return | 2.3.4 |
| LocalTermination PofR | | | | 3.2.6 |
| Intersystem-Termination PofR | | | | |

E.3.2 In-Call Flash Attempt GSL

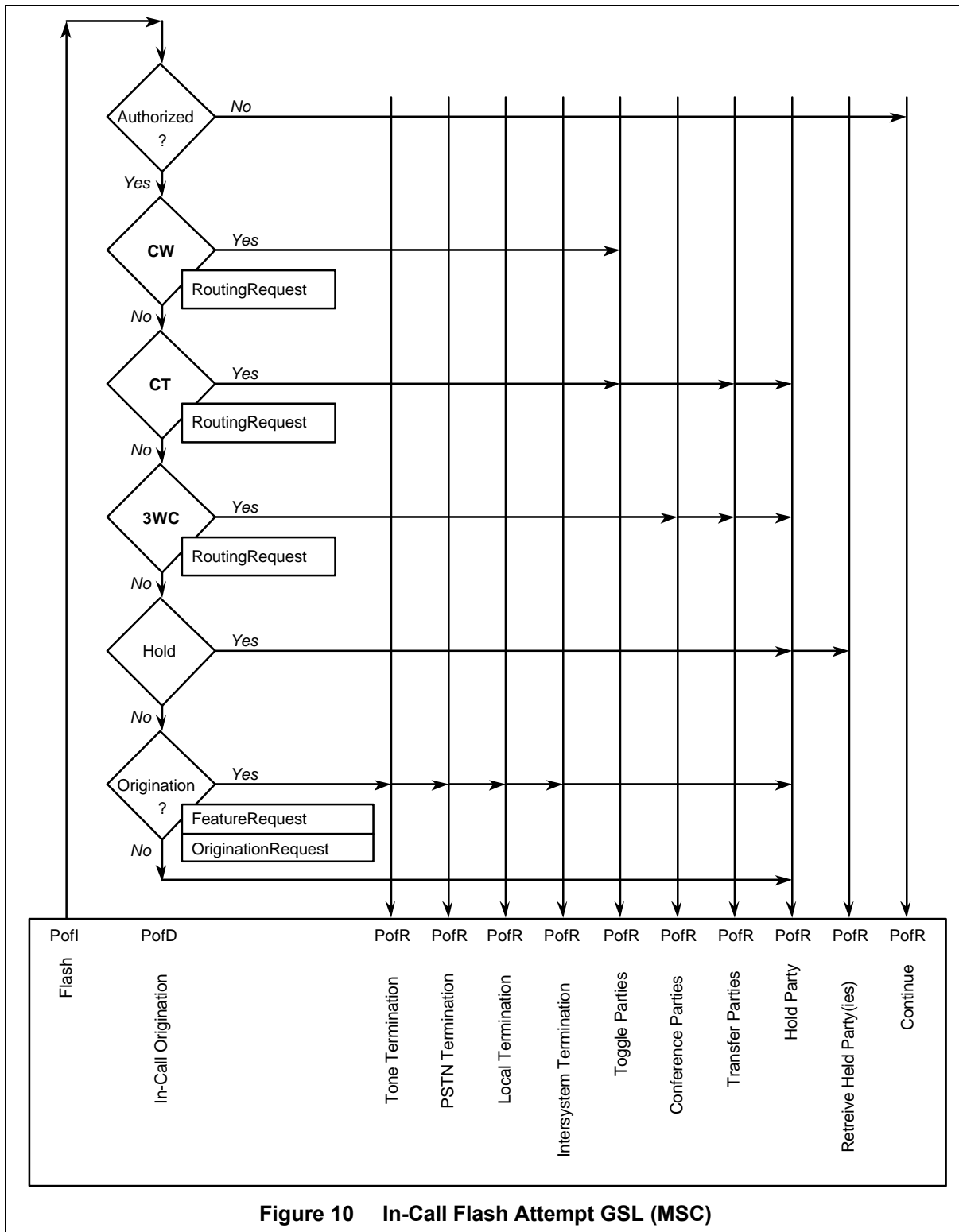

1
2
3
4
5
6
7
8
9
10
11
12
13
14
15
16
17
18
19
20
21
22
23
24
25
26
27
28
29
30
31
32
33
34
35
36
37
38
39
40
41
42
43
44
45
46
47
48
49
50
51
52
53
54
55
56
57
58
59
60

Table 69 In-Call Flash Attempt GSL (MSC)

| Symbol Name | Main Task Name | Ref. | Uses Task Name | Ref. |
|------------------------------|----------------------------------|----------------|--|----------------|
| Flash Pofl | In Call Flash Attempt | 3.2.2 | | |
| Authorized SSL | In Call Flash Attempt | 3.2.2 | | |
| CW SSL | In Call Flash Attempt | 3.2.2 | | |
| CT SSL | In Call Flash Attempt | 3.2.2 | | |
| 3WC SSL | In Call Flash Attempt | 3.2.2 | | |
| Hold SSL | In Call Flash Attempt | 3.2.2 | | |
| Feature SSL | MSC Analyze Mobile Dialed Number | E.3.3
3.2.3 | MSC Detecting Feature Request | 4.14.1 |
| Origination SSL | MSC Analyze Mobile Dialed Number | 3.2.3 | MSC Initiation of an Origination Request | 4.31.1 |
| | | | MSC Remote User Interaction | 4.39.2 |
| Continue PofR | In Call Flash Attempt | 3.2.2 | | |
| ToneTermination PofR | Idle Mobile Origination | 3.2.1 | Apply Busy Treatment | 3.4.4 |
| | | | Apply Access Denial Treatment | 3.4.5 |
| | | | Play All Announcements in the AnnouncementList | 3.2.5 |
| PSTNTermination PofR | Idle Mobile Origination | 3.2.1 | MSC Routing Points of Return | E.3.4
3.2.6 |
| | | | | E.3.4
3.2.6 |
| LocalTermination PofR | | | | |
| Intersystem-Termination PofR | | | | |

E.3.3 Feature Code GSL

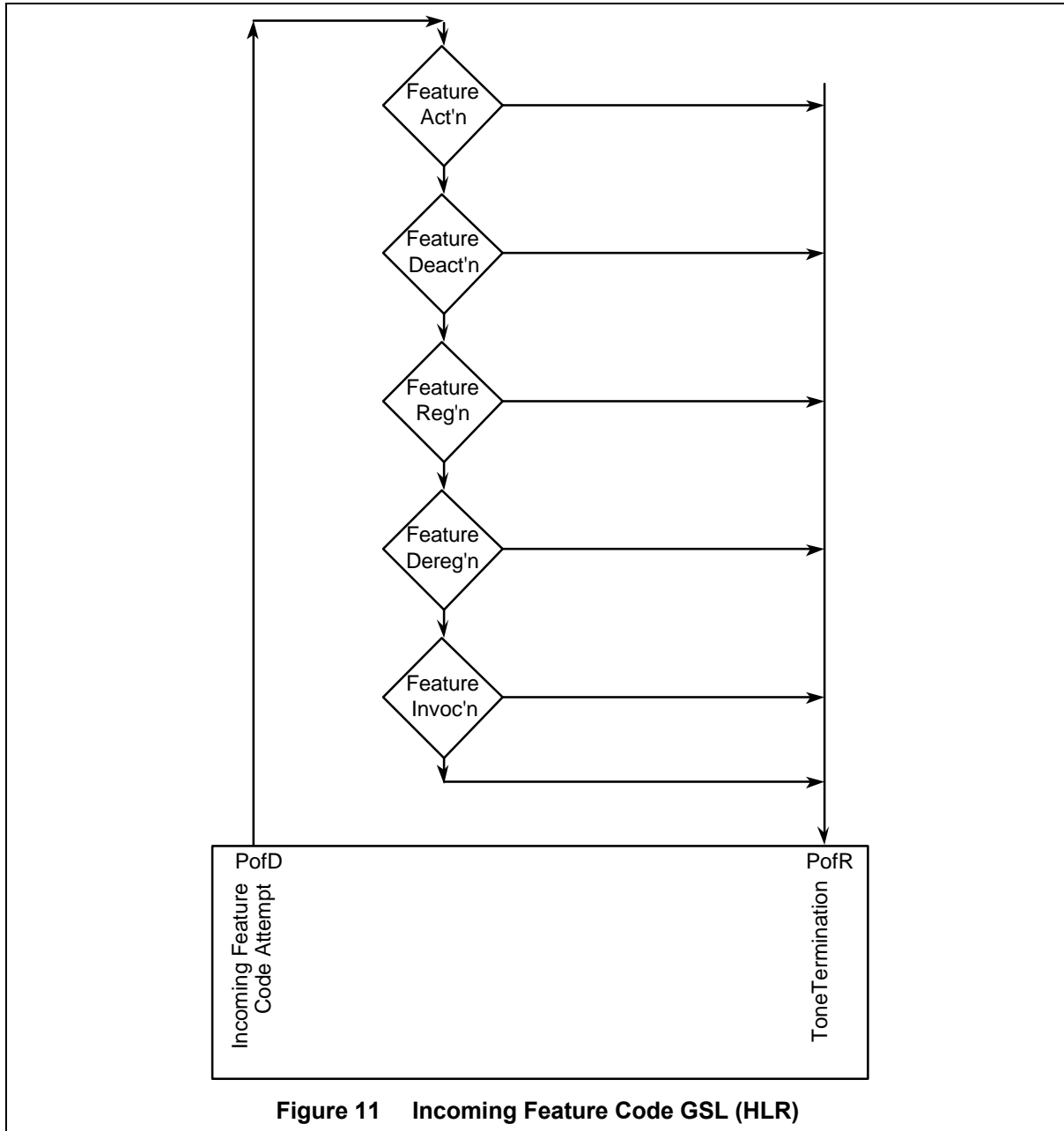

Figure 11 Incoming Feature Code GSL (HLR)

1
2
3
4
5
6
7
8
9
10
11
12
13
14
15
16
17
18
19
20
21
22
23
24
25
26
27
28
29
30
31
32
33
34
35
36
37
38
39
40
41
42
43
44
45
46
47
48
49
50
51
52
53
54
55
56
57
58
59
60

Table 70 Incoming Feature Code GSL (HLR)

| Symbol Name | Main Task Name | Ref. | Uses Task Name | Ref. |
|------------------------------------|---------------------------------------|-------------|--|----------------|
| Incoming Feature Code Attempt PofD | HLR Receiving a FeatureRequest INVOKE | 4.14.3 | | |
| Feature Activation SSLs | HLR Receiving a FeatureRequest INVOKE | 4.14.3 | Various | 9.x.x |
| Feature De-activation SSLs | | | HLR Initiating a Qualification Directive | 4.32.1 |
| Feature Registrations SSLs | | | HLR Initiating a Information Directive | 4.22.1 |
| Feature De-Registrations SSLs | | | | |
| Feature Invocation SSLs | | | | |
| ToneTermination PofR | MSC Detecting Feature Request | 4.14.1 | Apply Access Denial Treatment | E.3.1
3.4.5 |
| | | | Play All Announcements in the AnnouncementList | E.3.1
3.2.5 |

1
2
3
4
5
6
7
8
9
10
11
12
13
14
15
16
17
18
19
20
21
22
23
24
25
26
27
28
29
30
31
32
33
34
35
36
37
38
39
40
41
42
43
44
45
46
47
48
49
50
51
52
53
54
55
56
57
58
59
60

E.3.4 Incoming Call Attempt GSL

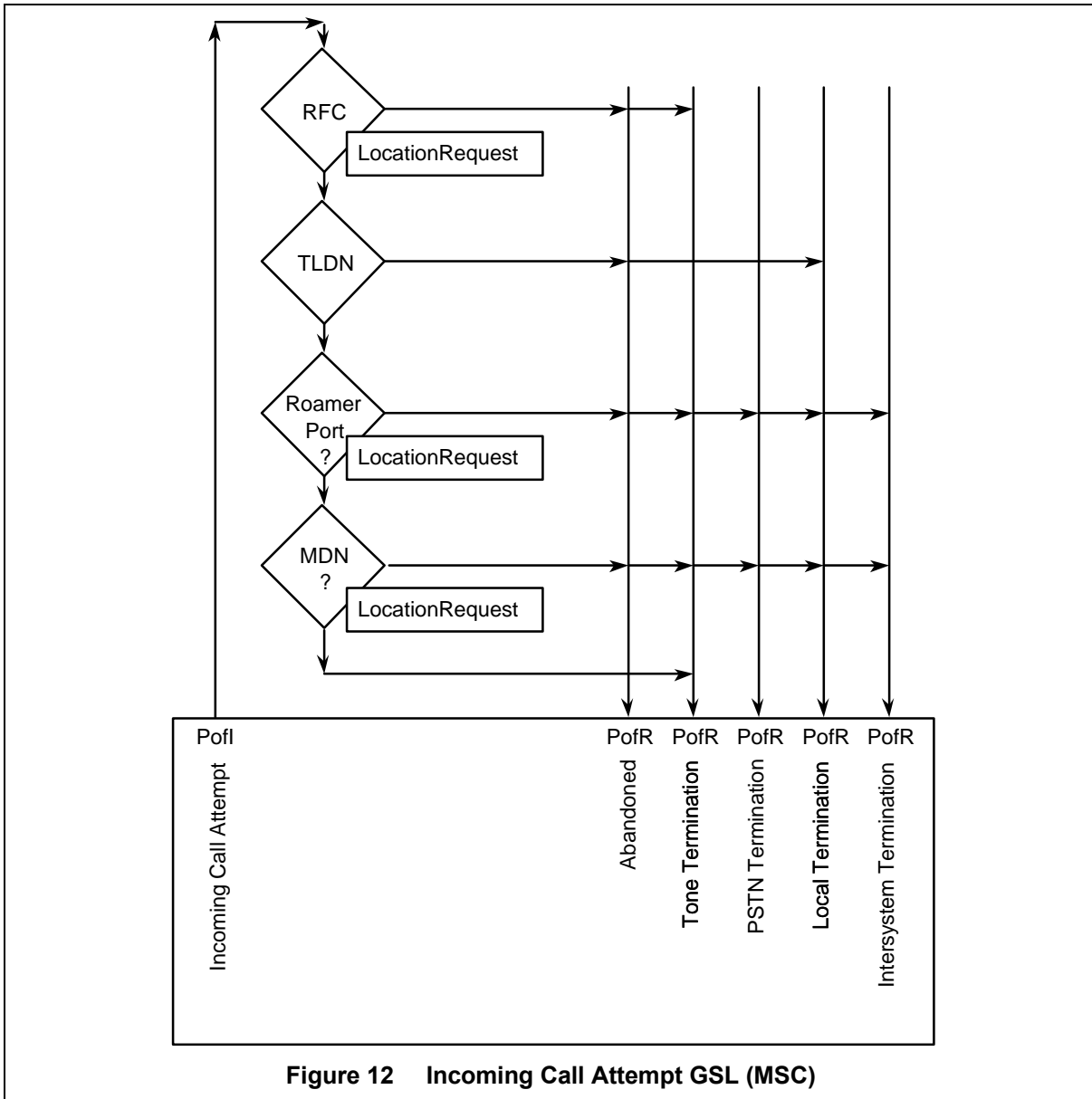

Figure 12 Incoming Call Attempt GSL (MSC)

1
2
3
4
5
6
7
8
9
10
11
12
13
14
15
16
17
18
19
20
21
22
23
24
25
26
27
28
29
30
31
32
33
34
35
36
37
38
39
40
41
42
43
44
45
46
47
48
49
50
51
52
53
54
55
56
57
58
59
60

Table 71 Incoming Call Attempt GSL (MSC)

| Symbol Name | Main Task Name | Ref. | Uses Task Name | Ref. |
|------------------------------|------------------------------------|-------------|--|-----------------|
| Incoming Call Attempt PofI | Incoming Call Attempt | 3.3.1 | | |
| RFC SSL | Incoming Call Attempt | 3.3.1 | MSC Initiation of Location Request | E.3.9
4.28.1 |
| TLDN? SSL | Wait for TLDN Call | 3.3.2 | | |
| Roamer Port? SSL | Incoming Call Attempt | 3.3.1 | MSC Initiation of Location Request | E.3.5
4.28.1 |
| MDN? SSL | Incoming Call Attempt | 3.3.1 | MSC Initiation of Location Request | E.3.5
4.28.1 |
| Abandoned PofR | MSC Initiation of Location Request | 4.28.1 | | |
| ToneTermination PofR | MSC Initiation of Location Request | 4.28.1 | Apply Busy Treatment | 3.4.4 |
| | | | Apply Access Denial Treatment | 3.4.5 |
| | | | Play All Announcements in the AnnouncementList | 3.2.5 |
| PSTNTermination PofR | MSC Initiation of Location Request | 4.28.1 | MSC Routing Points of Return | 3.2.6 |
| LocalTermination PofR | | | | |
| Intersystem-Termination PofR | | | | |

E.3.5 Incoming MDN Call Attempt GSL

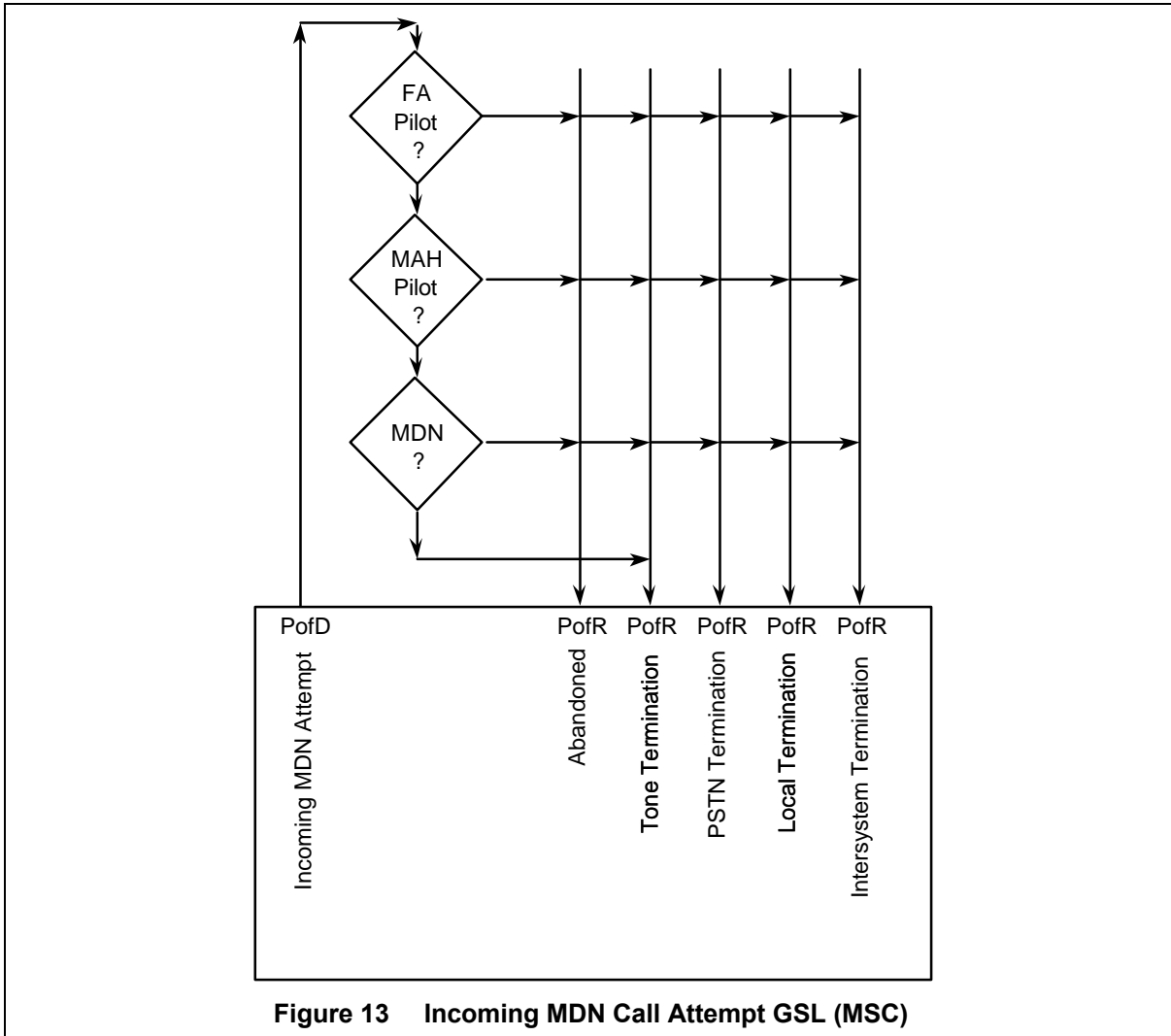

Figure 13 Incoming MDN Call Attempt GSL (MSC)

1
2
3
4
5
6
7
8
9
10
11
12
13
14
15
16
17
18
19
20
21
22
23
24
25
26
27
28
29
30
31
32
33
34
35
36
37
38
39
40
41
42
43
44
45
46
47
48
49
50
51
52
53
54
55
56
57
58
59
60

Table 72 Incoming MDN Call Attempt GSL (MSC)

| Symbol Name | Main Task Name | Ref. | Uses Task Name | Ref. |
|------------------------------|--|-------------|--|-----------------|
| Incoming MDN PofD | HLR Receiving a LocationRequest INVOKE | 4.28.2 | | |
| FA Pilot? SSL | HLR Receiving a LocationRequest INVOKE | 4.28.2 | HLR FA Incoming Call Invocation | E.3.6
5.12.3 |
| MAH Pilot? SSL | HLR Receiving a LocationRequest INVOKE | 4.28.2 | HLR MAH Incoming Call Invocation | E.3.7
5.14.4 |
| MDN? SSL | HLR Receiving a LocationRequest INVOKE | 4.28.2 | Incoming MS Call Attempt | E.3.8 |
| Abandoned PofR | MSC Initiation of Location Request | 4.28.1 | | E.3.4 |
| ToneTermination PofR | MSC Initiation of Location Request | 4.28.1 | Apply Busy Treatment | E.3.4
3.4.4 |
| | | | Apply Access Denial Treatment | E.3.4
3.4.5 |
| | | | Play All Announcements in the AnnouncementList | E.3.4
3.2.5 |
| PSTNTermination PofR | MSC Initiation of Location Request | 4.28.1 | MSC Routing Points of Return | E.3.4
3.2.6 |
| LocalTermination PofR | | | | |
| Intersystem-Termination PofR | | | | |

Table 73 Incoming FA Call Attempt GSL (HLR)

| Symbol Name | Main Task Name | Ref. | Uses Task Name | Ref. |
|-------------------------------|------------------------------------|-------------|---|----------------|
| Incoming FA Call Attempt PofD | HLR FA Incoming Call Invocation | 5.12.3 | | |
| FA Active? SSL | HLR FA Incoming Call Invocation | 5.12.3 | HLR Initiation of Routing Request | 4.41.1 |
| FA SCA SSL | For further study. | | HLR Initiation of Routing Request | 4.41.1 |
| FA PCA SSL | For further study. | | HLR Initiation of Routing Request | 4.41.1 |
| | | | HLR Initiation of Remote User Interaction Directive | 4.39.1 |
| FA CFNA SSL | For further study. | | HLR Initiation of Routing Request | 4.41.1 |
| FA CFD SSL | For further study. | | HLR Initiation of Routing Request | 4.41.1 |
| FA DND SSL | For further study. | | | |
| Term Authorized SSL | HLR FA Incoming Call Invocation | 5.12.3 | | |
| FA CD SSL | HLR FA Incoming Call Invocation | 5.12.3 | HLR Initiation of Routing Request | 4.41.1 |
| Busy PofD | HLR FA Incoming Call Invocation | 5.12.3 | | |
| Waitable PofD | HLR FA Incoming Call Invocation | 5.12.3 | | |
| Inactive PofD | HLR FA Incoming Call Invocation | 5.12.3 | | |
| Unavailable PofD | HLR FA Incoming Call Invocation | 5.12.3 | | |
| Unresponsive PofD | HLR FA Incoming Call Invocation | 5.12.3 | | |
| Unroutable PofD | HLR FA Incoming Call Invocation | 5.12.3 | | |
| Abandoned PofR | MSC Initiation of Location Request | 4.28.1 | | E.3.4 |
| ToneTermination PofR | MSC Initiation of Location Request | 4.28.1 | Apply Busy Treatment | E.3.4
3.4.4 |
| | | | Apply Access Denial Treatment | E.3.4
3.4.5 |
| | | | Play All Announcements in the AnnouncementList | E.3.4
3.2.5 |
| PSTNTermination PofR | MSC Initiation of Location Request | 4.28.1 | MSC Routing Points of Return | E.3.4
3.2.6 |
| LocalTermination PofR | | | | |
| Intersystem-Termination PofR | | | | |

E.3.7 Incoming MAH Call Attempt GSL

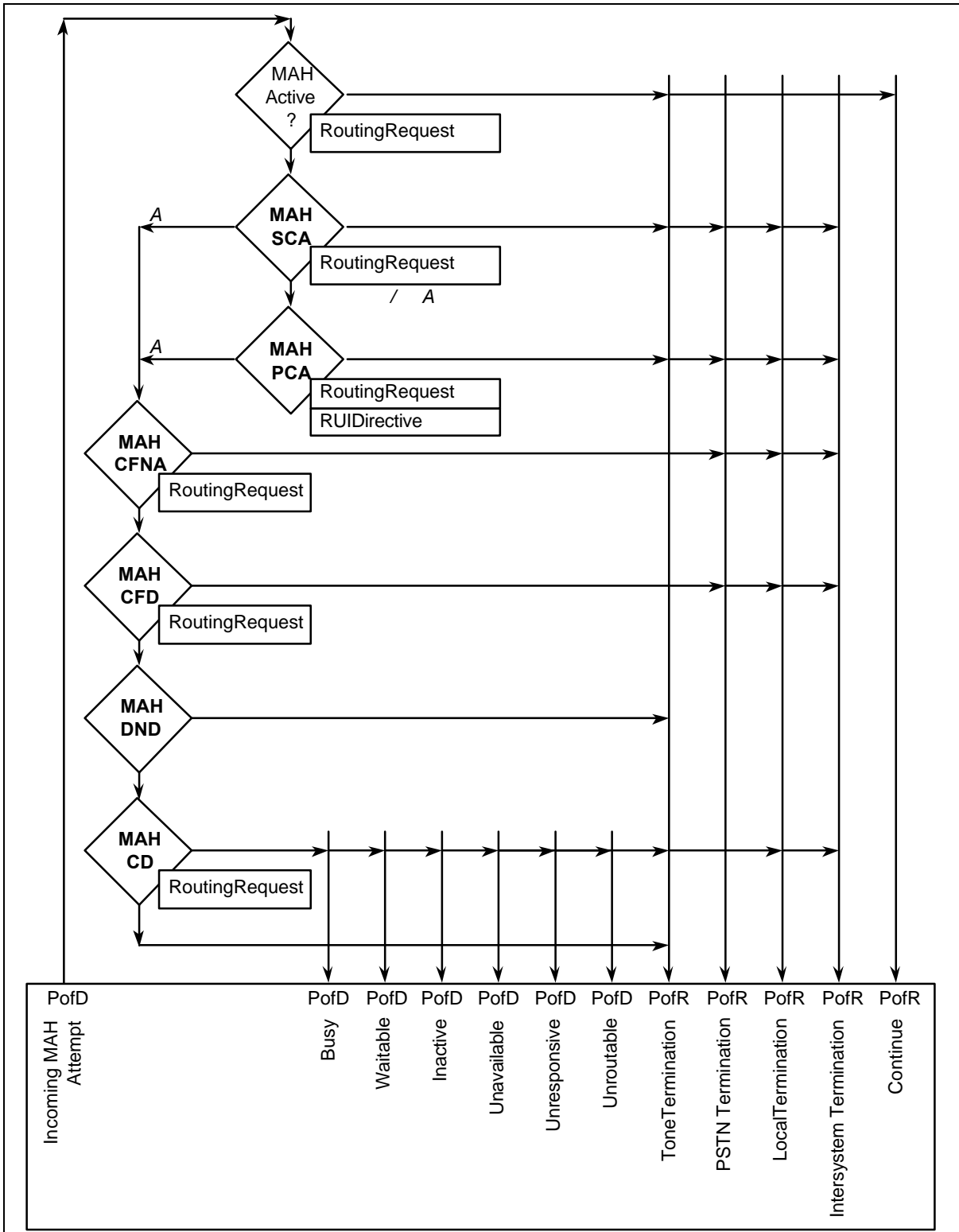

Figure 15 Incoming MAH Call Attempt GSL (HLR)

1
2
3
4
5
6
7
8
9
10
11
12
13
14
15
16
17
18
19
20
21
22
23
24
25
26
27
28
29
30
31
32
33
34
35
36
37
38
39
40
41
42
43
44
45
46
47
48
49
50
51
52
53
54
55
56
57
58
59
60

Table 74 Incoming MAH Call Attempt GSL (HLR)

| Symbol Name | Main Task Name | Ref. | Uses Task Name | Ref. |
|--------------------------------|------------------------------------|--------|---|----------------|
| Incoming MAH Call Attempt PofD | HLR MAH Incoming Call Invocation | 5.14.4 | | |
| MAH Active? SSL | HLR MAH Incoming Call Invocation | 5.14.4 | HLR Initiation of Routing Request | 4.41.1 |
| MAH SCA SSL | For further study. | | HLR Initiation of Routing Request | 4.41.1 |
| MAH PCA SSL | For further study. | | HLR Initiation of Routing Request | 4.41.1 |
| | | | HLR Initiation of Remote User Interaction Directive | 4.39.1 |
| MAH CFNA SSL | For further study. | | HLR Initiation of Routing Request | 4.41.1 |
| MAH CFD SSL | For further study. | | HLR Initiation of Routing Request | 4.41.1 |
| MAH DND SSL | For further study. | | | |
| Term Authorized SSL | HLR MAH Incoming Call Invocation | 5.14.4 | | |
| MAH CD SSL | HLR MAH Incoming Call Invocation | 5.14.4 | HLR Initiation of Routing Request | 4.41.1 |
| Busy PofD | HLR MAH Incoming Call Invocation | 5.14.4 | | |
| Waitable PofD | HLR MAH Incoming Call Invocation | 5.14.4 | | |
| Inactive PofD | HLR MAH Incoming Call Invocation | 5.14.4 | | |
| Unavailable PofD | HLR MAH Incoming Call Invocation | 5.14.4 | | |
| Unresponsive PofD | HLR MAH Incoming Call Invocation | 5.14.4 | | |
| Unroutable PofD | HLR MAH Incoming Call Invocation | 5.14.4 | | |
| Abandoned PofR | MSC Initiation of Location Request | 4.28.1 | | E.3.4 |
| ToneTermination PofR | MSC Initiation of Location Request | 4.28.1 | Apply Busy Treatment | E.3.4
3.4.4 |
| | | | Apply Access Denial Treatment | E.3.4
3.4.5 |
| | | | Play All Announcements in the AnnouncementList | E.3.4
3.2.5 |
| PSTNTermination PofR | MSC Initiation of Location Request | 4.28.1 | MSC Routing Points of Return | E.3.4
3.2.6 |
| LocalTermination PofR | | | | |
| Intersystem-Termination PofR | | | | |

Table 75 Incoming MS Call Attempt GSL (HLR)

| Symbol Name | Main Task Name | Ref. | Uses Task Name | Ref. |
|-------------------------------|--|-----------------|---|----------------|
| Incoming MS Call Attempt PofD | HLR Receiving a LocationRequest INVOKE | 4.28.2 | | |
| CFU SSL | HLR CFU Incoming Call Invocation | 9.5.5 | HLR Initiation of Routing Request | 4.41.1 |
| | | | HLR Initiation of Information Directive | 4.22.1 |
| SCA SSL | HLR SCA Incoming Call Invocation | 5.19.7 | HLR Initiation of Routing Request | 4.41.1 |
| PCA SSL | HLR PCA Incoming Call Invocation | 5.15.7 | HLR Initiation of Routing Request | 4.41.1 |
| | | | HLR Initiation of Remote User Interaction Directive | 4.39.1 |
| CFNA SSL | HLR CFNA Incoming Call Invocation Task | 9.4.5 | HLR Initiation of Routing Request | 4.41.1 |
| CFD SSL | HLR CFD Incoming Call Invocation | 9.3.5 | HLR Initiation of Routing Request | 4.41.1 |
| DND SSL | HLR DND Incoming Call Invocation | 5.11.3 | | |
| Term Authorized SSL | HLR Receiving a LocationRequest INVOKE | 4.28.2 | | |
| CD SSL | HLR CD Incoming Call Invocation | 5.1.5 | HLR Initiation of Routing Request | 4.41.1 |
| Busy PofD | HLR CD Incoming Call Invocation | E.3.10
5.1.5 | | |
| Waitable PofD | HLR CD Incoming Call Invocation | E.3.12
5.1.5 | | |
| Inactive PofD | HLR CD Incoming Call Invocation | E.3.13
5.1.5 | | |
| Unavailable PofD | HLR CD Incoming Call Invocation | E.3.15
5.1.5 | | |
| Unresponsive PofD | HLR CD Incoming Call Invocation | E.3.17
5.1.5 | | |
| Unroutable PofD | HLR CD Incoming Call Invocation | E.1.14
5.1.5 | | |
| Abandoned PofR | MSC Initiation of Location Request | 4.24.1 | | E.3.4 |
| ToneTermination PofR | MSC Initiation of Location Request | 4.28.1 | Apply Busy Treatment | E.3.4
3.4.4 |
| | | | Apply Access Denial Treatment | E.3.4
3.4.5 |
| | | | Play All Announcements in the AnnouncementList | E.3.4
3.2.5 |
| PSTNTermination PofR | MSC Initiation of Location Request | 4.28.1 | MSC Routing Points of Return | E.3.4
3.2.6 |
| LocalTermination PofR | | | | |
| Intersystem-Termination PofR | | | | |

E.3.9 Incoming RFC Call Attempt GSL

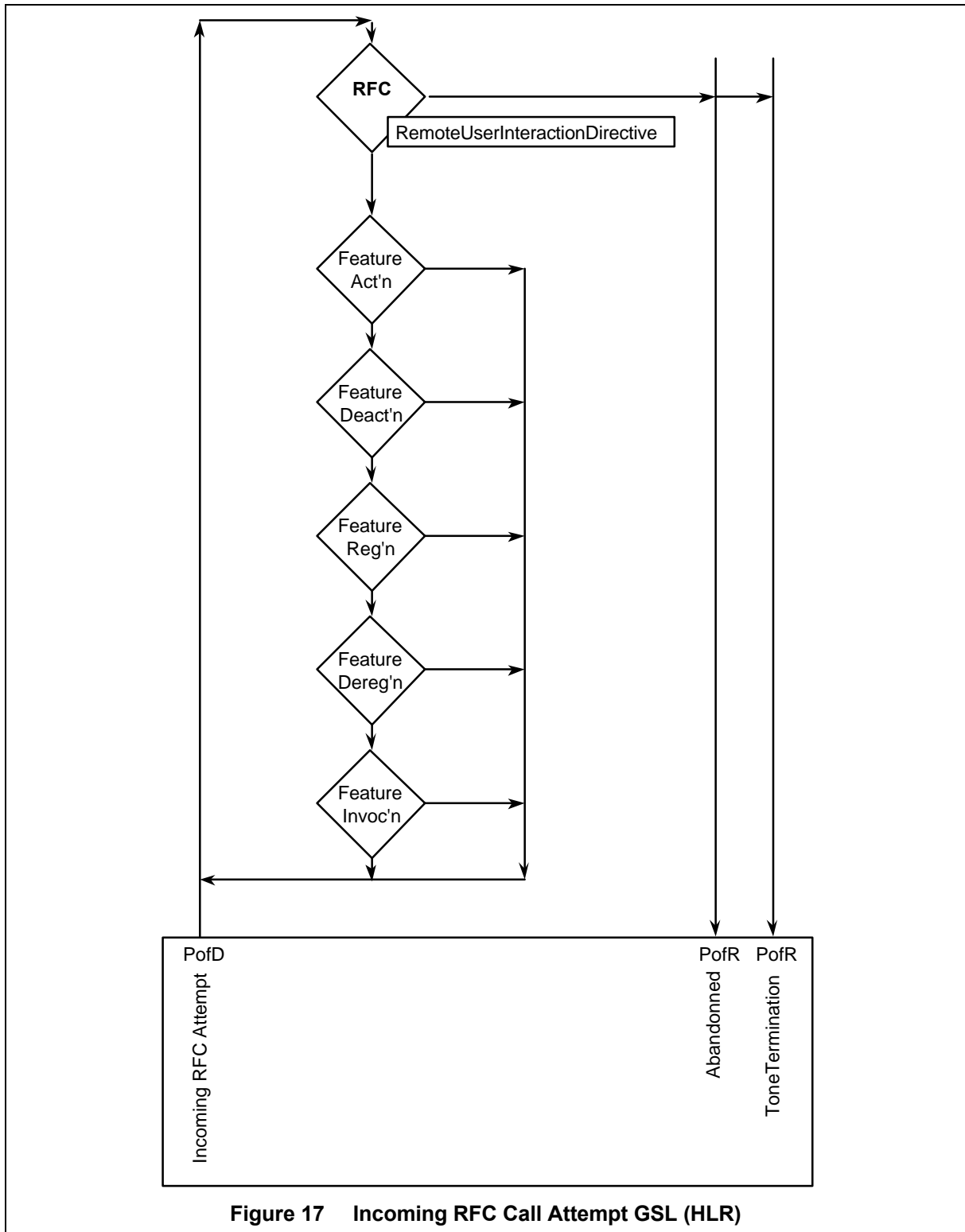

1
2
3
4
5
6
7
8
9
10
11
12
13
14
15
16
17
18
19
20
21
22
23
24
25
26
27
28
29
30
31
32
33
34
35
36
37
38
39
40
41
42
43
44
45
46
47
48
49
50
51
52
53
54
55
56
57
58
59
60

Table 76 Incoming RFC Call Attempt GSL (HLR)

| Symbol Name | Main Task Name | Ref. | Uses Task Name | Ref. |
|-------------------------------|--|-------------|---|----------------|
| Incoming RFC Attempt PofD | HLR Receiving a LocationRequest INVOKE | 4.28.2 | | |
| RFC SSL | HLR RFC Incoming Call Invocation | 5.18.1 | HLR Initiation of Remote User Interaction Directive | 4.39.1 |
| Feature Activation SSLs | HLR RFC Incoming Call Invocation | 5.18.1 | Various | 9.x.x |
| Feature De-activation SSLs | | | | |
| Feature Registrations SSLs | | | | |
| Feature De-Registrations SSLs | | | | |
| Feature Invocation SSLs | | | | |
| Abandoned PofR | MSC Initiation of Location Request | 4.28.1 | | E.3.4 |
| ToneTermination PofR | MSC Initiation of Location Request | 4.28.1 | Apply Busy Treatment | E.3.4
3.4.4 |
| | | | Apply Access Denial Treatment | E.3.4
3.4.5 |
| | | | Play All Announcements in the AnnouncementList | E.3.4
3.2.5 |

1
2
3
4
5
6
7
8
9
10
11
12
13
14
15
16
17
18
19
20
21
22
23
24
25
26
27
28
29
30
31
32
33
34
35
36
37
38
39
40
41
42
43
44
45
46
47
48
49
50
51
52
53
54
55
56
57
58
59
60

E.3.10 Busy MS Detected GSL

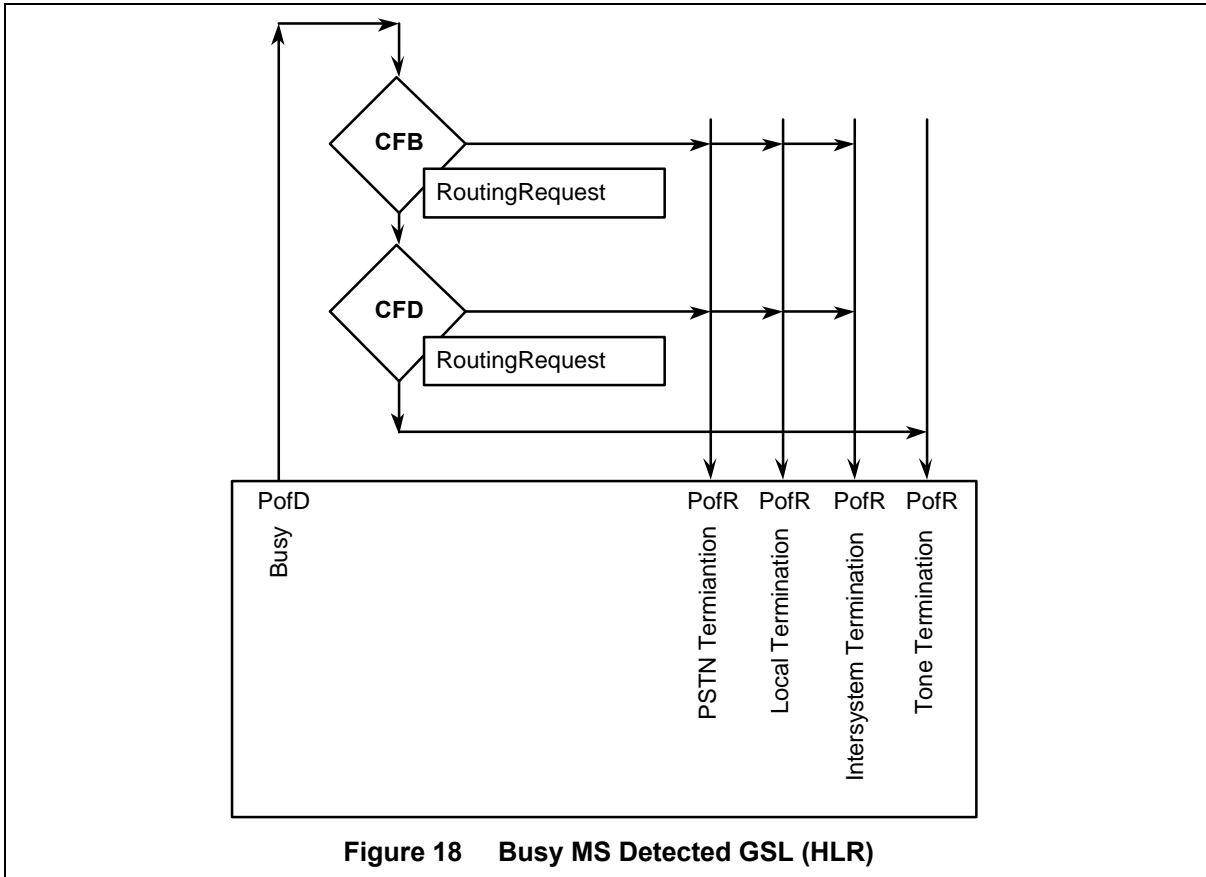

1
2
3
4
5
6
7
8
9
10
11
12
13
14
15
16
17
18
19
20
21
22
23
24
25
26
27
28
29
30
31
32
33
34
35
36
37
38
39
40
41
42
43
44
45
46
47
48
49
50
51
52
53
54
55
56
57
58
59
60

Table 77 Busy MS Detected GSL (HLR)

| Symbol Name | Main Task Name | Ref. | Uses Task Name | Ref. |
|------------------------------|------------------------------------|-------------|--|----------------|
| Busy PofD | HLR CD Incoming Call Invocation | 5.1.5 | | |
| CFB SSL | HLR CFB Busy MS Invocation | 5.2.5 | HLR Initiation of Routing Request | 4.41.1 |
| CFD SSL | HLR CFD Busy Call Invocation | 9.3.9 | HLR Initiation of Routing Request | 4.41.1 |
| ToneTermination PofR | MSC Initiation of Location Request | 4.28.1 | Apply Busy Treatment | E.3.4
3.4.4 |
| | | | Apply Access Denial Treatment | E.3.4
3.4.5 |
| | | | Play All Announcements in the AnnouncementList | E.3.4
3.2.5 |
| PSTNTermination PofR | MSC Initiation of Location Request | 4.28.1 | MSC Routing Points of Return | E.3.4
3.2.6 |
| LocalTermination PofR | | | | |
| Intersystem-Termination PofR | | | | |

1
2
3
4
5
6
7
8
9
10
11
12
13
14
15
16
17
18
19
20
21
22
23
24
25
26
27
28
29
30
31
32
33
34
35
36
37
38
39
40
41
42
43
44
45
46
47
48
49
50
51
52
53
54
55
56
57
58
59
60

E.3.11 Busy Re-Routing GSL

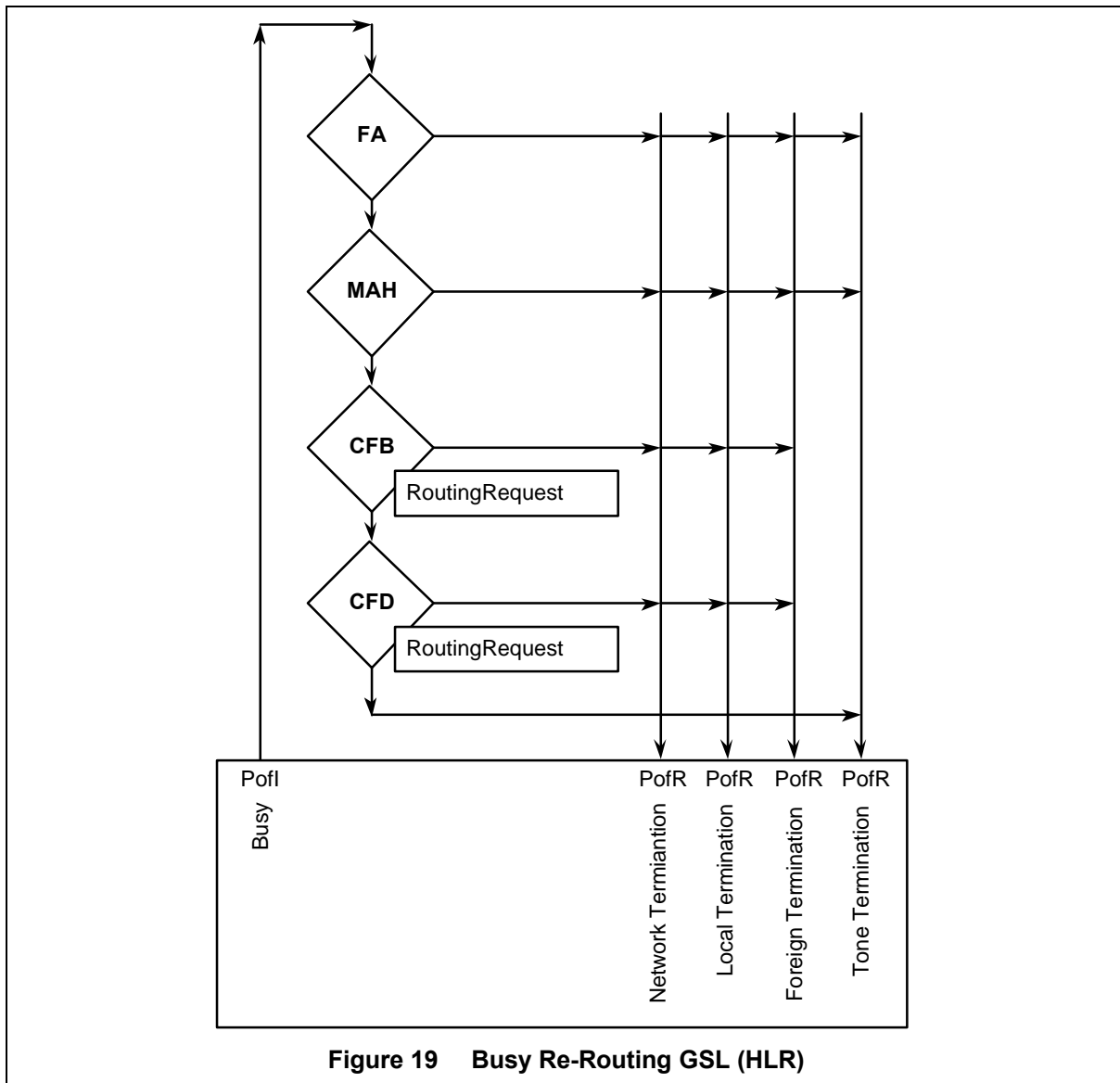

Figure 19 Busy Re-Routing GSL (HLR)

1
2
3
4
5
6
7
8
9
10
11
12
13
14
15
16
17
18
19
20
21
22
23
24
25
26
27
28
29
30
31
32
33
34
35
36
37
38
39
40
41
42
43
44
45
46
47
48
49
50
51
52
53
54
55
56
57
58
59
60

Table 78 Busy Re-Routing GSL (HLR)

| Symbol Name | Main Task Name | Ref. | Uses Task Name | Ref. |
|------------------------------|--|-------------|--|-------------|
| Busy Pofl | HLR Receiving Transfer-to-Number Request | 4.49.2 | | |
| FA SSL | HLR FA Busy MS Invocation | 5.12.5 | HLR Initiation of Routing Request | 4.41.1 |
| MAH SSL | HLR MAH Busy MS Invocation | 5.14.6 | HLR Initiation of Routing Request | 4.41.1 |
| CFB SSL | HLR CFB Busy MS Invocation | 5.2.5 | HLR Initiation of Routing Request | 4.41.1 |
| CFD SSL | HLR CFD Incoming Call Invocation | 9.3.9 | HLR Initiation of Routing Request | 4.41.1 |
| ToneTermination PofR | MSC Initiation of Redirection Request | 4.35.1 | Apply Busy Treatment | 3.4.4 |
| | MSC Initiation of Transfer-to-Number Request | 4.49.1 | Apply Access Denial Treatment | 3.4.5 |
| | | | Play All Announcements in the AnnouncementList | 3.2.5 |
| PSTNTermination PofR | MSC Initiation of Redirection Request | 4.36.1 | MSC Routing Points of Return | 3.2.6 |
| LocalTermination PofR | MSC Initiation of Transfer-to-Number Request | 4.49.1 | | |
| Intersystem-Termination PofR | | | | |

1
2
3
4
5
6
7
8
9
10
11
12
13
14
15
16
17
18
19
20
21
22
23
24
25
26
27
28
29
30
31
32
33
34
35
36
37
38
39
40
41
42
43
44
45
46
47
48
49
50
51
52
53
54
55
56
57
58
59
60

E.3.12 Waitable MS Detected GSL

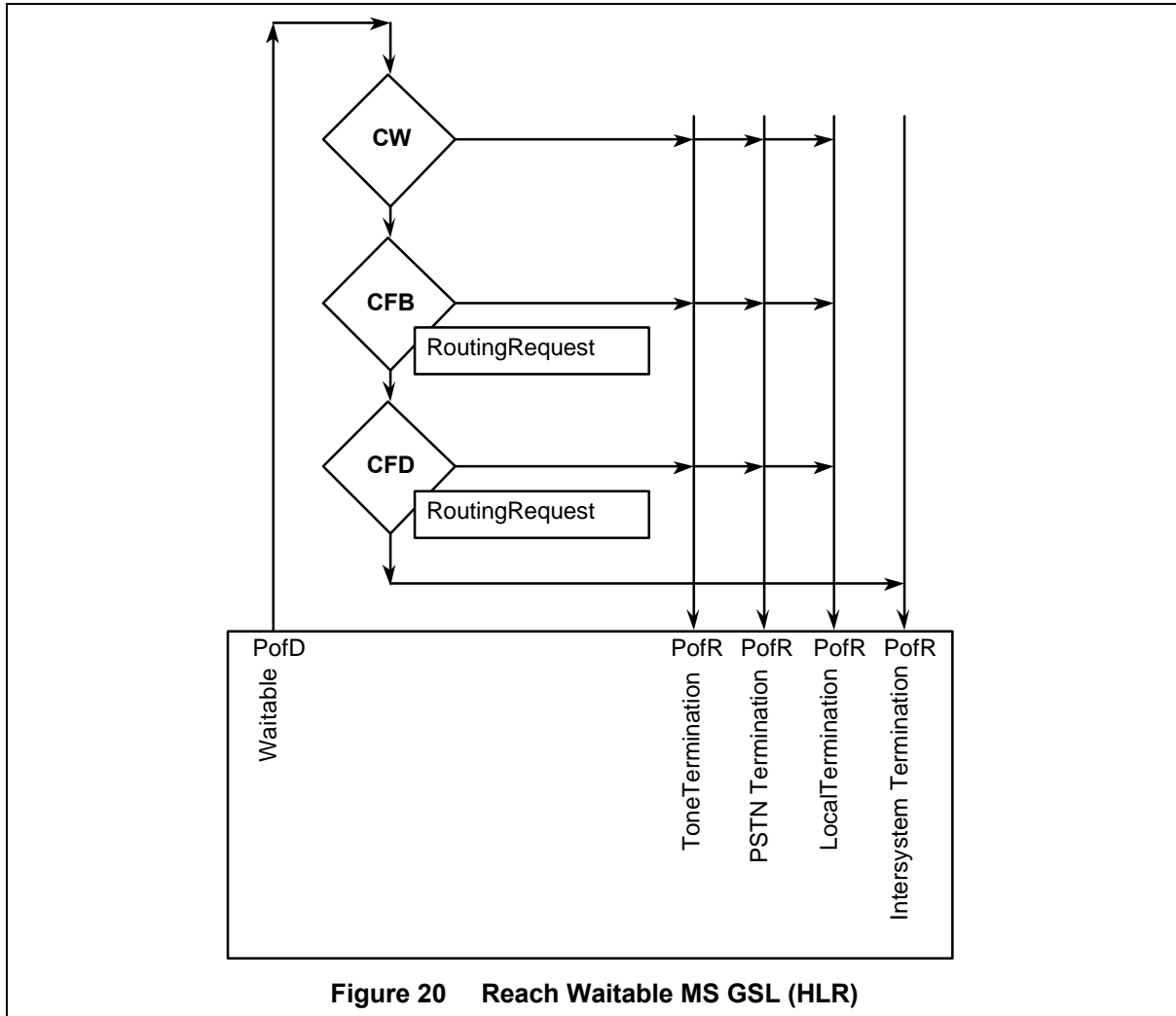

1
2
3
4
5
6
7
8
9
10
11
12
13
14
15
16
17
18
19
20
21
22
23
24
25
26
27
28
29
30
31
32
33
34
35
36
37
38
39
40
41
42
43
44
45
46
47
48
49
50
51
52
53
54
55
56
57
58
59
60

Table 79 Reach Waitable MS GSL (HLR)

| Symbol Name | Main Task Name | Ref. | Uses Task Name | Ref. |
|------------------------------|------------------------------------|-------------|--|----------------|
| Waitable PofD | HLR CD Incoming Call Invocation | 5.1.5 | | |
| CFB SSL | HLR CFB Busy MS Invocation | 5.2.5 | HLR Initiation of Routing Request | 4.41.1 |
| CFD SSL | HLR CFD Busy MS Invocation | 9.3.9 | HLR Initiation of Routing Request | 4.41.1 |
| ToneTermination PofR | MSC Initiation of Location Request | 4.28.1 | Apply Busy Treatment | E.3.4
3.4.4 |
| | | | Apply Access Denial Treatment | E.3.4
3.4.5 |
| | | | Play All Announcements in the AnnouncementList | E.3.4
3.2.5 |
| PSTNTermination PofR | MSC Initiation of Location Request | 4.28.1 | MSC Routing Points of Return | E.3.4
3.2.6 |
| LocalTermination PofR | | | | |
| Intersystem-Termination PofR | | | | |

1
2
3
4
5
6
7
8
9
10
11
12
13
14
15
16
17
18
19
20
21
22
23
24
25
26
27
28
29
30
31
32
33
34
35
36
37
38
39
40
41
42
43
44
45
46
47
48
49
50
51
52
53
54
55
56
57
58
59
60

E.3.13 Inactive MS Detected GSL

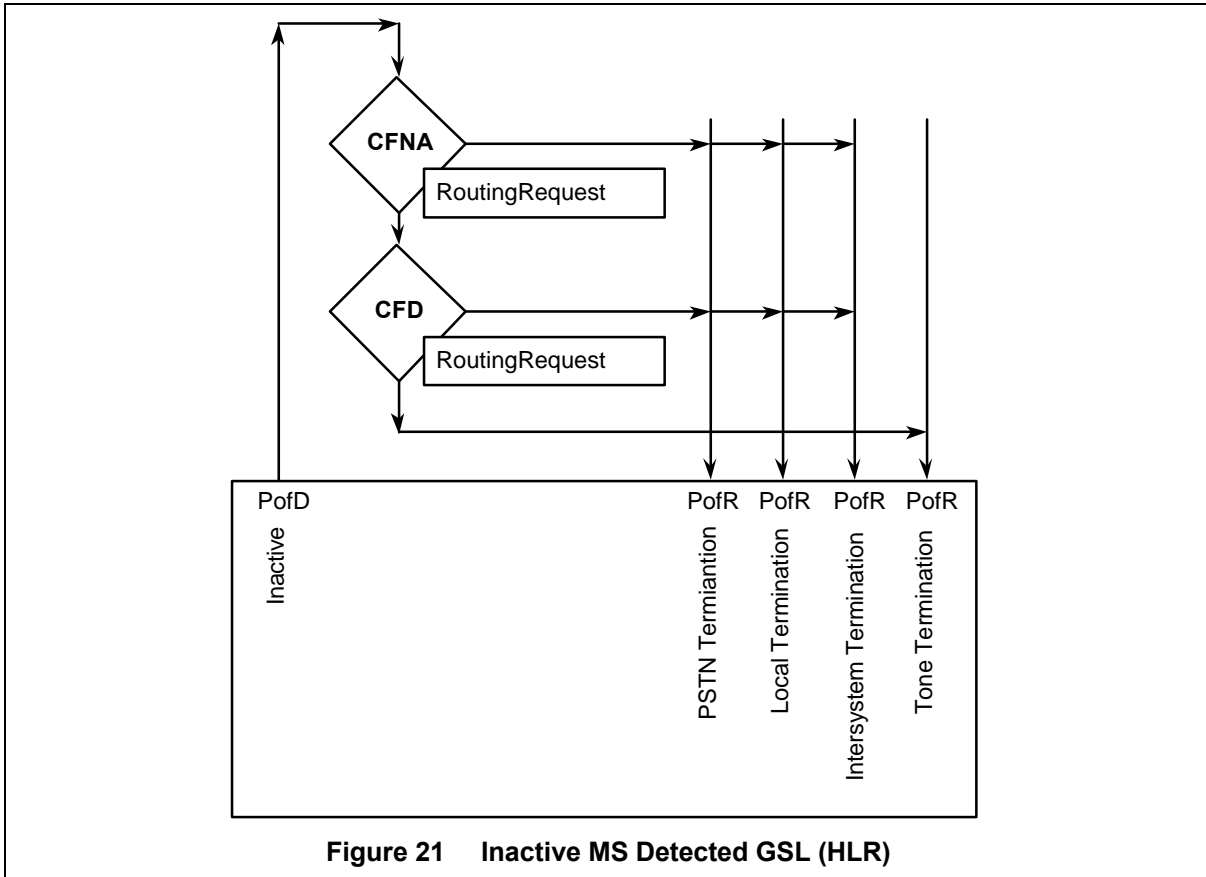

Figure 21 Inactive MS Detected GSL (HLR)

1
2
3
4
5
6
7
8
9
10
11
12
13
14
15
16
17
18
19
20
21
22
23
24
25
26
27
28
29
30
31
32
33
34
35
36
37
38
39
40
41
42
43
44
45
46
47
48
49
50
51
52
53
54
55
56
57
58
59
60

Table 80 Inactive MS Detected GSL (HLR)

| Symbol Name | Main Task Name | Ref. | Uses Task Name | Ref. |
|------------------------------|------------------------------------|-------------|--|----------------|
| Inactive PofD | HLR CD Incoming Call Invocation | 5.1.5 | | |
| CFNA SSL | HLR CFNA Inactive MS Invocation | 9.4.6 | HLR Initiation of Routing Request | 4.41.1 |
| CFD SSL | HLR CFD Inactive MS Invocation | 9.3.6 | HLR Initiation of Routing Request | 4.41.1 |
| ToneTermination PofR | MSC Initiation of Location Request | 4.28.1 | Apply Busy Treatment | E.3.4
3.4.4 |
| | | | Apply Access Denial Treatment | E.3.4
3.4.5 |
| | | | Play All Announcements in the AnnouncementList | E.3.4
3.2.5 |
| PSTNTermination PofR | MSC Initiation of Location Request | 4.28.1 | MSC Routing Points of Return | E.3.4
3.2.6 |
| LocalTermination PofR | | | | |
| Intersystem-Termination PofR | | | | |

E.3.14 Inactive Re-Routing GSL

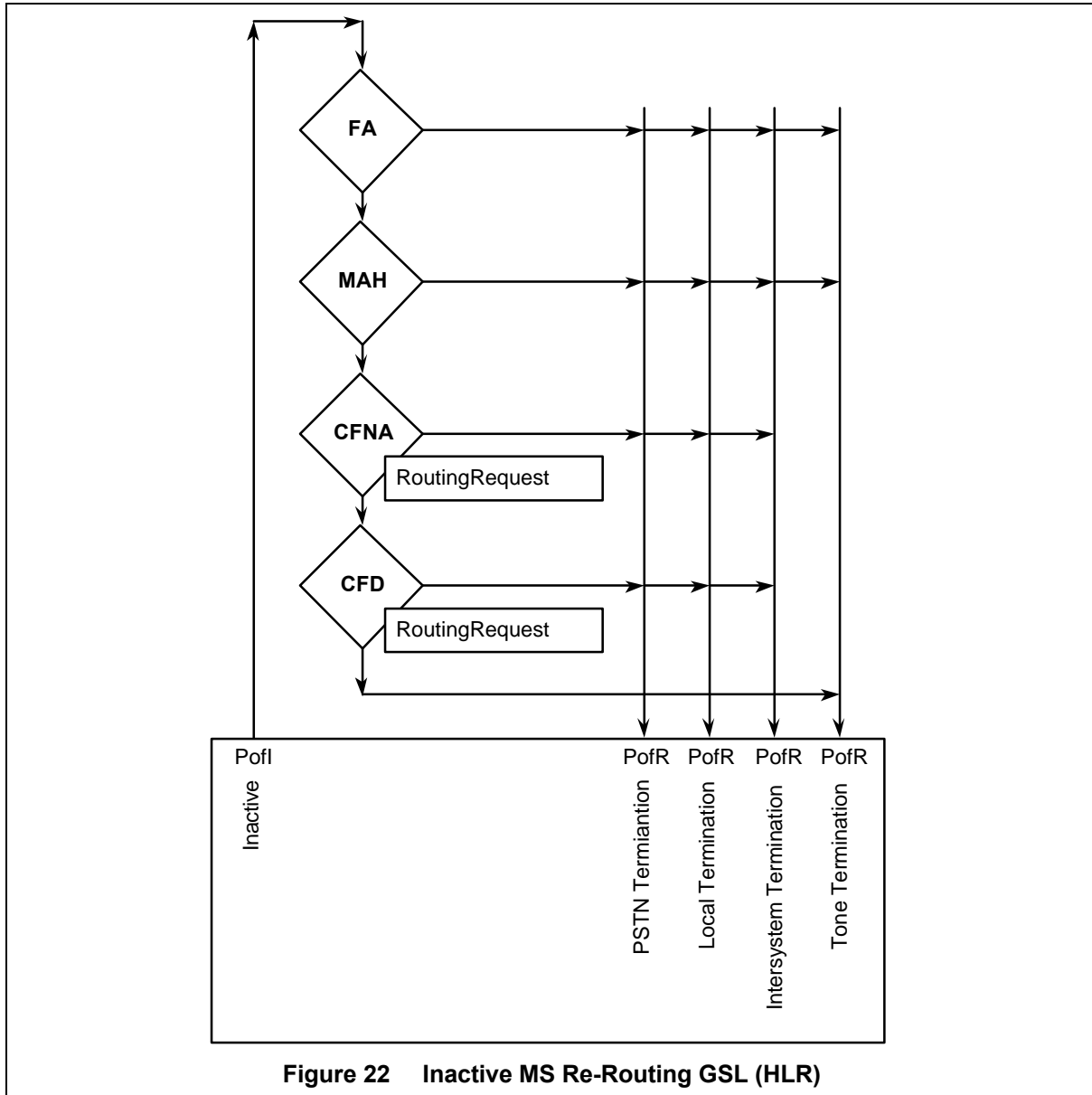

Figure 22 Inactive MS Re-Routing GSL (HLR)

1
2
3
4
5
6
7
8
9
10
11
12
13
14
15
16
17
18
19
20
21
22
23
24
25
26
27
28
29
30
31
32
33
34
35
36
37
38
39
40
41
42
43
44
45
46
47
48
49
50
51
52
53
54
55
56
57
58
59
60

Table 81 Inactive MS Re-Routing GSL (HLR)

| Symbol Name | Main Task Name | Ref. | Uses Task Name | Ref. |
|------------------------------|--|-------------|--|-------------|
| Inactive PofD | HLR Receiving Transfer-to-Number Request | 4.49.2 | | |
| FA SSL | HLR FA Inactive MS Invocation | 5.12.6 | HLR Initiation of Routing Request | 4.41.1 |
| MAH SSL | HLR MAH Inactive MS Invocation | 5.14.7 | HLR Initiation of Routing Request | 4.41.1 |
| CFNA SSL | HLR CFNA Inactive MS Invocation | 9.4.6 | HLR Initiation of Routing Request | 4.41.1 |
| CFD SSL | HLR CFD Inactive MS Invocation | 9.3.6 | HLR Initiation of Routing Request | 4.41.1 |
| ToneTermination PofR | MSC Initiation of Redirection Request | 4.36.1 | Apply Busy Treatment | 3.4.4 |
| | MSC Initiation of Transfer-to-Number Request | 4.49.1 | Apply Access Denial Treatment | 3.4.5 |
| | | | Play All Announcements in the AnnouncementList | 3.2.5 |
| PSTNTermination PofR | MSC Initiation of Redirection Request | 4.36.1 | MSC Routing Points of Return | 3.2.6 |
| LocalTermination PofR | MSC Initiation of Transfer-to-Number Request | 4.49.1 | | |
| Intersystem-Termination PofR | | | | |

1
2
3
4
5
6
7
8
9
10
11
12
13
14
15
16
17
18
19
20
21
22
23
24
25
26
27
28
29
30
31
32
33
34
35
36
37
38
39
40
41
42
43
44
45
46
47
48
49
50
51
52
53
54
55
56
57
58
59
60

E.3.15 Unavailable MS Detected GSL

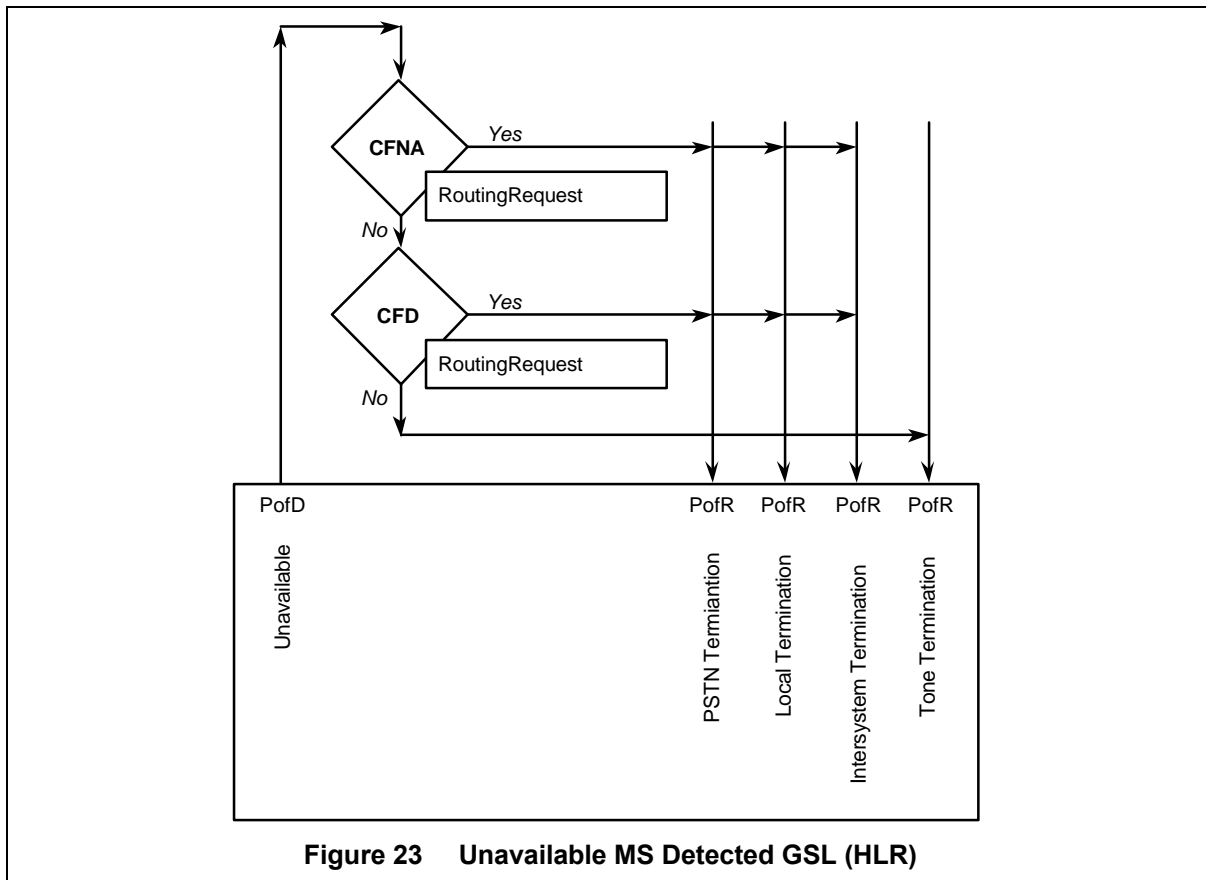

Figure 23 Unavailable MS Detected GSL (HLR)

1
2
3
4
5
6
7
8
9
10
11
12
13
14
15
16
17
18
19
20
21
22
23
24
25
26
27
28
29
30
31
32
33
34
35
36
37
38
39
40
41
42
43
44
45
46
47
48
49
50
51
52
53
54
55
56
57
58
59
60

Table 82 Unavailable MS Detected GSL (HLR)

| Symbol Name | Main Task Name | Ref. | Uses Task Name | Ref. |
|------------------------------|------------------------------------|-------------|--|----------------|
| Unavailable PofD | HLR CD Incoming Call Invocation | 5.1.5 | | |
| CFNA SSL | HLR CFNA Unavailable MS Invocation | 9.4.7 | HLR Initiation of Routing Request | 4.41.1 |
| CFD SSL | HLR CFD Unavailable MS Invocation | 9.3.7 | HLR Initiation of Routing Request | 4.41.1 |
| ToneTermination PofR | MSC Initiation of Location Request | 4.28.1 | Apply Busy Treatment | E.3.4
3.4.4 |
| | | | Apply Access Denial Treatment | E.3.4
3.4.5 |
| | | | Play All Announcements in the AnnouncementList | E.3.4
3.2.5 |
| PSTNTermination PofR | MSC Initiation of Location Request | 4.28.1 | MSC Routing Points of Return | E.3.4
3.2.6 |
| LocalTermination PofR | | | | |
| Intersystem-Termination PofR | | | | |

1
2
3
4
5
6
7
8
9
10
11
12
13
14
15
16
17
18
19
20
21
22
23
24
25
26
27
28
29
30
31
32
33
34
35
36
37
38
39
40
41
42
43
44
45
46
47
48
49
50
51
52
53
54
55
56
57
58
59
60

Table 83 Unavailable MS Re-Routing GSL (HLR)

| Symbol Name | Main Task Name | Ref. | Uses Task Name | Ref. |
|------------------------------|--|-------------|--|-------------|
| Unavailable PofD | HLR Receiving Transfer-to-Number Request | 4.49.2 | | |
| FA SSL | HLR FA Unavailable MS Invocation | 5.12.7 | HLR Initiation of Routing Request | 4.41.1 |
| MAH SSL | HLR MAH Unavailable MS Invocation | 5.14.8 | HLR Initiation of Routing Request | 4.41.1 |
| CFNA SSL | HLR CFNA Unavailable MS Invocation | 9.4.7 | HLR Initiation of Routing Request | 4.41.1 |
| CFD SSL | HLR CFD Unavailable MS Invocation | 9.3.7 | HLR Initiation of Routing Request | 4.41.1 |
| ToneTermination PofR | MSC Initiation of Redirection Request | 4.36.1 | Apply Busy Treatment | 3.4.4 |
| | MSC Initiation of Transfer-to-Number Request | 4.49.1 | Apply Access Denial Treatment | 3.4.5 |
| | | | Play All Announcements in the AnnouncementList | 3.2.5 |
| PSTNTermination PofR | MSC Initiation of Redirection Request | 4.36.1 | MSC Routing Points of Return | 3.2.6 |
| LocalTermination PofR | MSC Initiation of Transfer-to-Number Request | 4.49.1 | | |
| Intersystem-Termination PofR | | | | |

1
2
3
4
5
6
7
8
9
10
11
12
13
14
15
16
17
18
19
20
21
22
23
24
25
26
27
28
29
30
31
32
33
34
35
36
37
38
39
40
41
42
43
44
45
46
47
48
49
50
51
52
53
54
55
56
57
58
59
60

E.3.17 Unresponsive MS Detected GSL

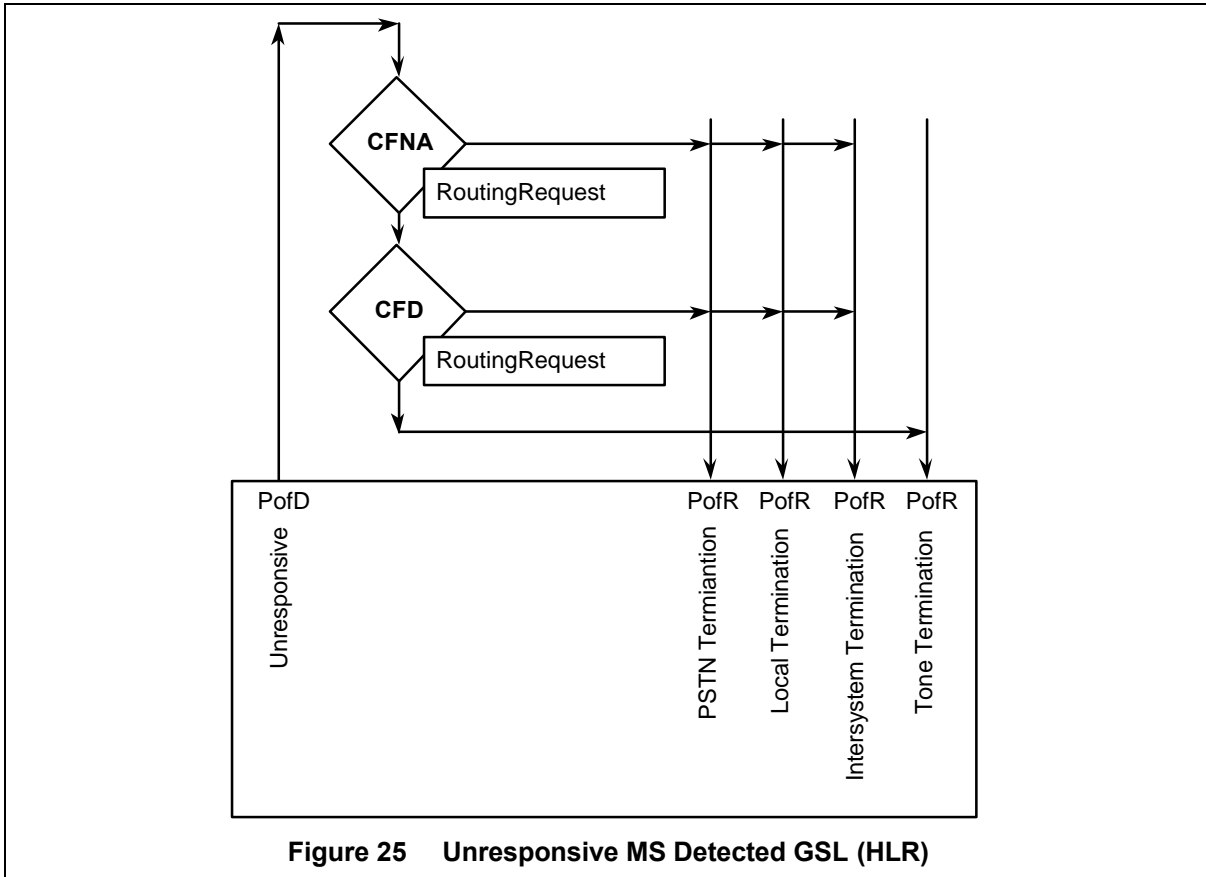

Figure 25 Unresponsive MS Detected GSL (HLR)

1
2
3
4
5
6
7
8
9
10
11
12
13
14
15
16
17
18
19
20
21
22
23
24
25
26
27
28
29
30
31
32
33
34
35
36
37
38
39
40
41
42
43
44
45
46
47
48
49
50
51
52
53
54
55
56
57
58
59
60

Table 84 Unresponsive MS Detected GSL (HLR)

| Symbol Name | Main Task Name | Ref. | Uses Task Name | Ref. |
|------------------------------|-------------------------------------|-------------|--|----------------|
| Unresponsive PofD | HLR CD Incoming Call Invocation | 5.1.5 | | |
| CFNA SSL | HLR CFNA Unresponsive MS Invocation | 9.4.8 | HLR Initiation of Routing Request | 4.41.1 |
| CFD SSL | HLR CFD Unresponsive MS Invocation | 9.3.8 | HLR Initiation of Routing Request | 4.41.1 |
| ToneTermination PofR | MSC Initiation of Location Request | 4.28.1 | Apply Busy Treatment | E.3.4
3.4.4 |
| | | | Apply Access Denial Treatment | E.3.4
3.4.5 |
| | | | Play All Announcements in the AnnouncementList | E.3.4
3.2.5 |
| PSTNTermination PofR | MSC Initiation of Location Request | 4.28.1 | MSC Routing Points of Return | E.3.4
3.2.6 |
| LocalTermination PofR | | | | |
| Intersystem-Termination PofR | | | | |

1
2
3
4
5
6
7
8
9
10
11
12
13
14
15
16
17
18
19
20
21
22
23
24
25
26
27
28
29
30
31
32
33
34
35
36
37
38
39
40
41
42
43
44
45
46
47
48
49
50
51
52
53
54
55
56
57
58
59
60

E.3.18 Unresponsive Re-Routing GSL

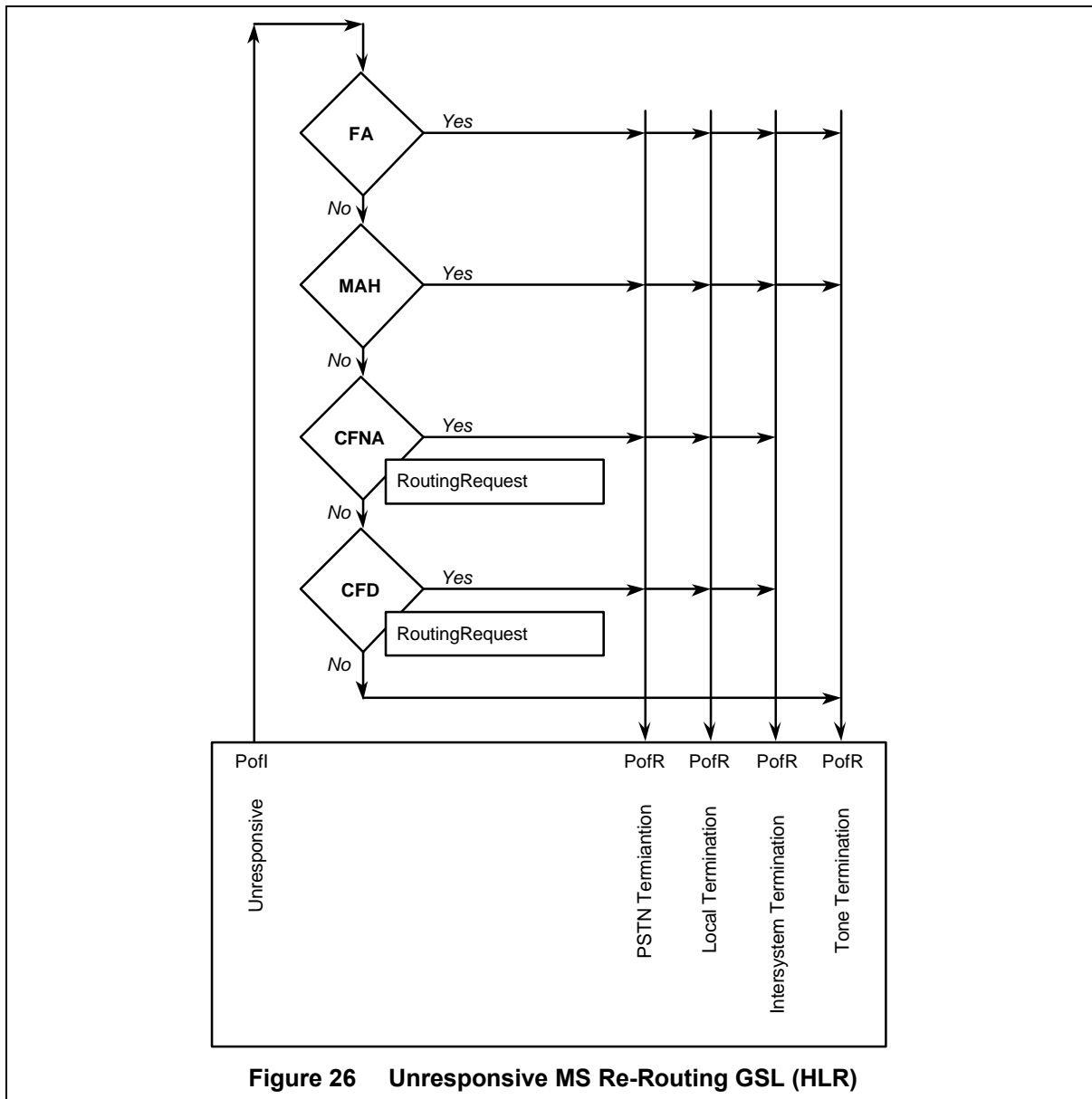

Figure 26 Unresponsive MS Re-Routing GSL (HLR)

1
2
3
4
5
6
7
8
9
10
11
12
13
14
15
16
17
18
19
20
21
22
23
24
25
26
27
28
29
30
31
32
33
34
35
36
37
38
39
40
41
42
43
44
45
46
47
48
49
50
51
52
53
54
55
56
57
58
59
60

Table 85 Unresponsive MS Re-Routing GSL (HLR)

| Symbol Name | Main Task Name | Ref. | Uses Task Name | Ref. |
|------------------------------|--|--------|--|--------|
| Unresponsive PofD | HLR Receiving Transfer-to-Number Request | 4.49.2 | | |
| FA SSL | HLR FA Unresponsive MS Invocation | 5.12.8 | HLR Initiation of Routing Request | 4.41.1 |
| MAH SSL | HLR MAH Unresponsive MS Invocation | 5.14.9 | HLR Initiation of Routing Request | 4.41.1 |
| CFNA SSL | HLR CFNA Unresponsive MS Invocation | 9.4.8 | HLR Initiation of Routing Request | 4.41.1 |
| CFD SSL | HLR CFD Unresponsive MS Invocation | 9.3.8 | HLR Initiation of Routing Request | 4.41.1 |
| ToneTermination PofR | MSC Initiation of Redirection Request | 4.36.1 | Apply Busy Treatment | 3.4.4 |
| | MSC Initiation of Transfer-to-Number Request | 4.49.1 | Apply Access Denial Treatment | 3.4.5 |
| | | | Play All Announcements in the AnnouncementList | 3.2.5 |
| PSTNTermination PofR | MSC Initiation of Redirection Request | 4.36.1 | MSC Routing Points of Return | 3.2.6 |
| LocalTermination PofR | MSC Initiation of Transfer-to-Number Request | 4.49.1 | | |
| Intersystem-Termination PofR | | | | |

1
2
3
4
5
6
7
8
9
10
11
12
13
14
15
16
17
18
19
20
21
22
23
24
25
26
27
28
29
30
31
32
33
34
35
36
37
38
39
40
41
42
43
44
45
46
47
48
49
50
51
52
53
54
55
56
57
58
59
60

E.3.20 Unroutable Call Detected GSL

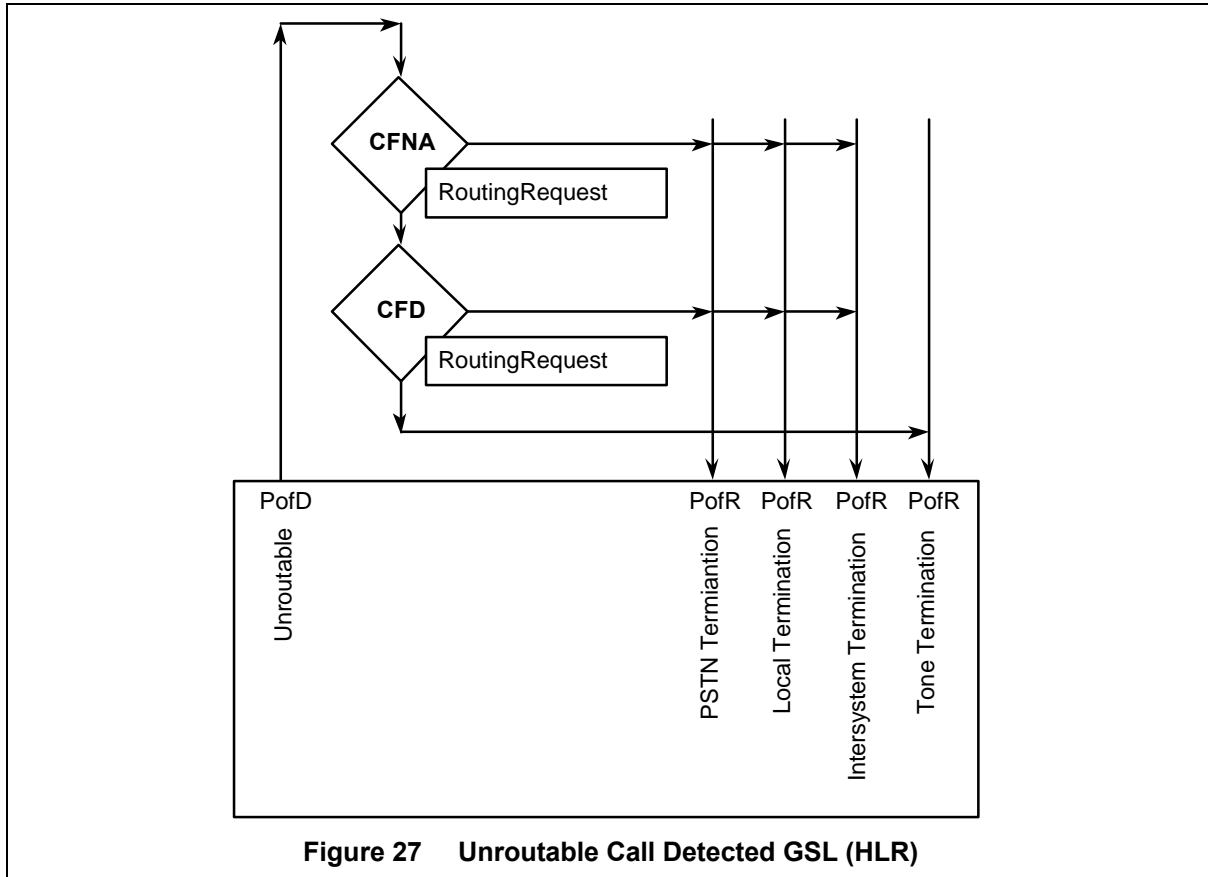

Figure 27 Unroutable Call Detected GSL (HLR)

1
2
3
4
5
6
7
8
9
10
11
12
13
14
15
16
17
18
19
20
21
22
23
24
25
26
27
28
29
30
31
32
33
34
35
36
37
38
39
40
41
42
43
44
45
46
47
48
49
50
51
52
53
54
55
56
57
58
59
60

Table 86 Unroutable Call Detected GSL (HLR)

| Symbol Name | Main Task Name | Ref. | Uses Task Name | Ref. |
|-----------------------------|------------------------------------|-------------|--|----------------|
| Unroutable PofD | HLR CD Incoming Call Invocation | 5.1.5 | | |
| CFNA SSL | HLR CFNA Unroutable MS Invocation | 9.4.10 | HLR Initiation of Routing Request | 4.41.1 |
| CFD SSL | HLR CFD Unroutable MS Invocation | 9.3.11 | HLR Initiation of Routing Request | 4.41.1 |
| ToneTermination PofR | MSC Initiation of Location Request | 4.28.1 | Apply Busy Treatment | E.3.4 |
| | | | Apply Access Denial Treatment | 3.4.4 |
| | | | Play All Announcements in the AnnouncementList | E.3.4
3.2.5 |
| PSTNTermination PofR | MSC Initiation of Location Request | 4.28.1 | MSC Routing Points of Return | E.3.4
3.2.6 |
| LocalTermination PofR | | | | |
| IntersystemTermination PofR | | | | |

1
2
3
4
5
6
7
8
9
10
11
12
13
14
15
16
17
18
19
20
21
22
23
24
25
26
27
28
29
30
31
32
33
34
35
36
37
38
39
40
41
42
43
44
45
46
47
48
49
50
51
52
53
54
55
56
57
58
59
60

E.3.20 Unroutable Call Re-Routing GSL

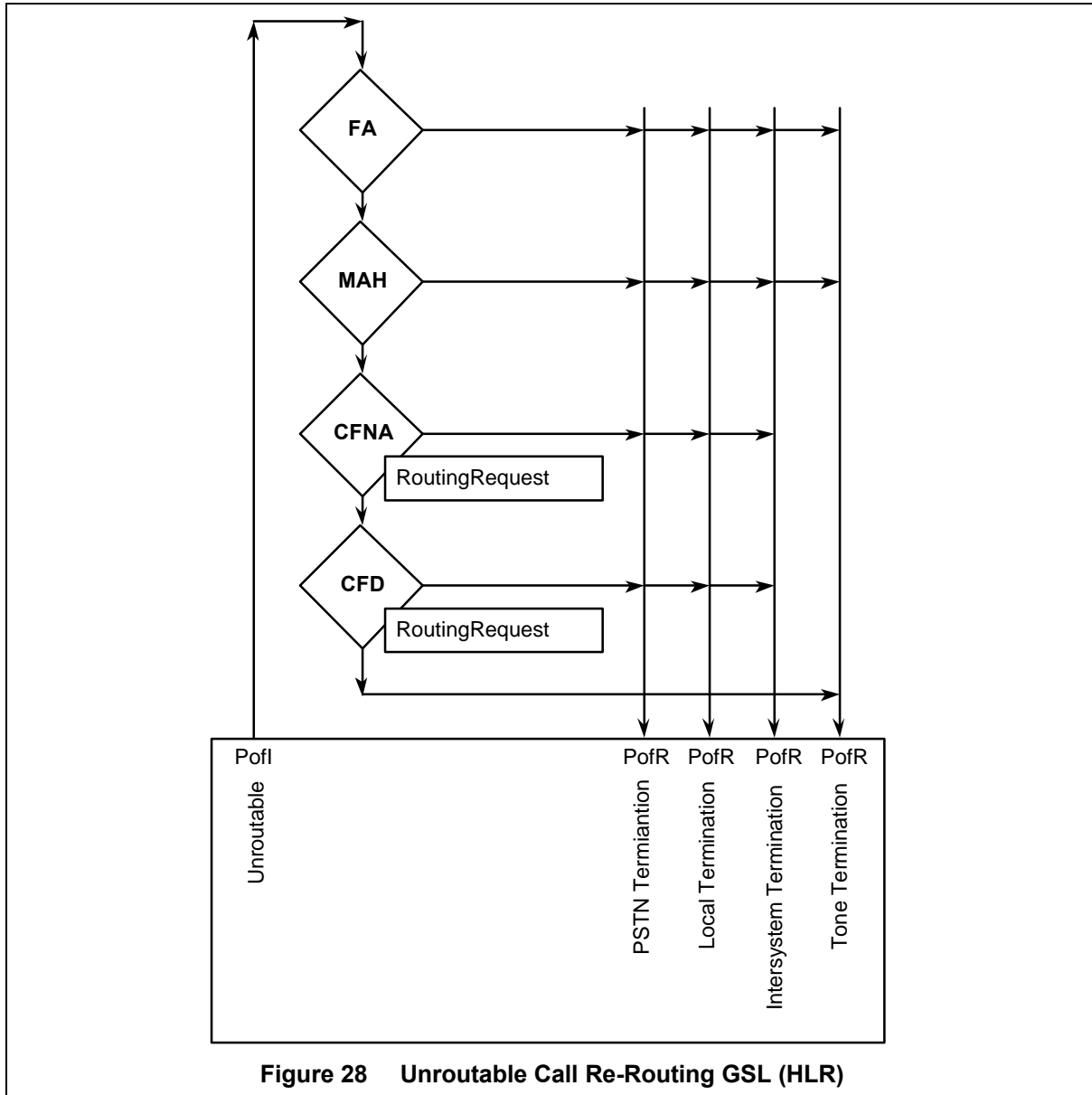

Figure 28 Unroutable Call Re-Routing GSL (HLR)

1
2
3
4
5
6
7
8
9
10
11
12
13
14
15
16
17
18
19
20
21
22
23
24
25
26
27
28
29
30
31
32
33
34
35
36
37
38
39
40
41
42
43
44
45
46
47
48
49
50
51
52
53
54
55
56
57
58
59
60

Table 87 Unroutable Call Re-Routing GSL (HLR)

| Symbol Name | Main Task Name | Ref. | Uses Task Name | Ref. |
|------------------------------|---|------------------|--|-------------|
| Unroutable PofD | HLR Receiving Transfer-to-Number Request | 4.49.2 | | |
| FA SSL | HLR FA Unroutable MS Invocation | 5.12.1
0 | HLR Initiation of Routing Request | 4.41.1 |
| MAH SSL | HLR MAH Unroutable MS Invocation | 5.14.1
1 | HLR Initiation of Routing Request | 4.41.1 |
| CFNA SSL | HLR CFNA Unroutable MS Invocation | 9.4.10 | HLR Initiation of Routing Request | 4.41.1 |
| CFD SSL | HLR CFD Unroutable MS Invocation | 9.3.11 | HLR Initiation of Routing Request | 4.41.1 |
| ToneTermination PofR | MSC Initiation of Redirection Request
MSC Initiation of Transfer-to-Number Request | 4.36.1
4.49.1 | Apply Busy Treatment | 3.4.4 |
| | | | Apply Access Denial Treatment | 3.4.5 |
| | | | Play All Announcements in the AnnouncementList | 3.2.5 |
| PSTNTermination PofR | MSC Initiation of Redirection Request | 4.36.1 | MSC Routing Points of Return | 3.2.6 |
| LocalTermination PofR | MSC Initiation of Transfer-to-Number Request | 4.49.1 | | |
| Intersystem-Termination PofR | | | | |

1
2
3
4
5
6
7
8
9
10
11
12
13
14
15
16
17
18
19
20
21
22
23
24
25
26
27
28
29
30
31
32
33
34
35
36
37
38
39
40
41
42
43
44
45
46
47
48
49
50
51
52
53
54
55
56
57
58
59
60

E.3.21 No Answer Call Re-Routing GSL

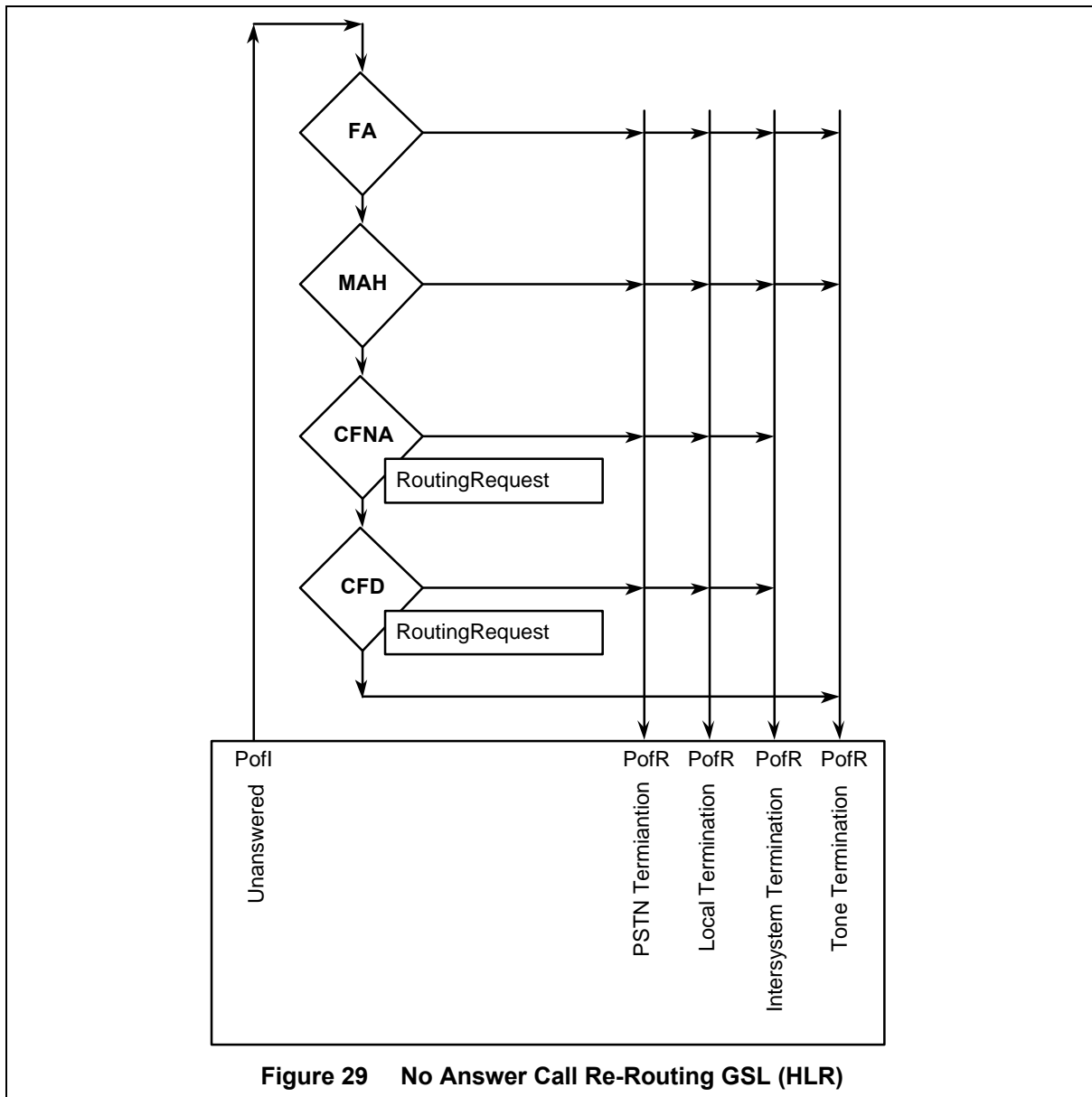

Figure 29 No Answer Call Re-Routing GSL (HLR)

1
2
3
4
5
6
7
8
9
10
11
12
13
14
15
16
17
18
19
20
21
22
23
24
25
26
27
28
29
30
31
32
33
34
35
36
37
38
39
40
41
42
43
44
45
46
47
48
49
50
51
52
53
54
55
56
57
58
59
60

Table 88 No Answer Call Re-Routing GSL (HLR)

| Symbol Name | Main Task Name | Ref. | Uses Task Name | Ref. |
|------------------------------|---|------------------|--|-------------|
| Unanswered PofD | HLR Receiving Transfer-to-Number Request | 4.49.2 | | |
| FA SSL | HLR FA No Answer MS Invocation | 5.12.9 | HLR Initiation of Routing Request | 4.41.1 |
| MAH SSL | HLR MAH No Answer MS Invocation | 5.14.1
0 | HLR Initiation of Routing Request | 4.41.1 |
| CFNA SSL | HLR CFNA No Answer MS Invocation | 9.4.9 | HLR Initiation of Routing Request | 4.41.1 |
| CFD SSL | HLR CFD No Answer MS Invocation | 9.3.10 | HLR Initiation of Routing Request | 4.41.1 |
| ToneTermination PofR | MSC Initiation of Redirection Request
MSC Initiation of Transfer-to-Number Request | 4.36.1
4.49.1 | Apply Busy Treatment | 3.4.4 |
| | | | Apply Access Denial Treatment | 3.4.5 |
| | | | Play All Announcements in the AnnouncementList | 3.2.5 |
| PSTNTermination PofR | MSC Initiation of Redirection Request | 4.36.1 | MSC Routing Points of Return | 3.2.6 |
| LocalTermination PofR | MSC Initiation of Transfer-to-Number Request | 4.49.1 | | |
| Intersystem-Termination PofR | | | | |

1
2
3
4
5
6
7
8
9
10
11
12
13
14
15
16
17
18
19
20
21
22
23
24
25
26
27
28
29
30
31
32
33
34
35
36
37
38
39
40
41
42
43
44
45
46
47
48
49
50
51
52
53
54
55
56
57
58
59
60

F ANNE F SIGNAL STRENGTH ARBITRATION

This annex is informative and is not considered part of this Standard.

F.1 REGISTRATION CANCELLATION RACE CONDITION ALGORITHM

An MS may re-register before the expected next registration time as a result of any one of the following conditions:

- 1) The RegistrationCancellation Race Condition problem occurs.
- 2) An MSC within the domain of a VLR overhears a registration or origination which occurs within the domain of a neighboring VLR (i.e., an MS registers on a new Serving MSC outside of the domain of the previous serving VLR and a cochannel co-DCC control channel within the domain of the previous serving VLR overhears the registration).
- 3) The MS is executing a power-up autonomous registration (e.g., a TDMA compliant MS) when the MS is already considered to be in the active state. This implies that either power-down autonomous registration has not been enabled or that the Serving MSC did not receive the power-down registration or power-down release order sent by the MS.
- 4) The MS did not hear the registration acknowledge message which the Serving MSC sent in response to the MS's autonomous registration, resulting in an MS entering the "Local Recovery Procedures" task and re-executing a registration access after a short delay.

The VLR may determine that the RegistrationCancellation Race Condition has occurred if all of the following conditions are true:

- The MS is in an active state when the RegistrationNotification is received. This activity status check is important because some MSs may execute an autonomous registration each time they power up (e.g., a TDMA MS with PUREG_S= 1)

AND

- The SystemAccessType parameter indicates that the current RegistrationNotification was sent to the VLR as a result of an autonomous registration which is not a power-down registration and the BorderCellAccess parameter indicates that the registration occurred on a border cell

AND

- The current RegistrationNotification is premature

AND

- The MSCID parameter of the current RegistrationNotification is the same as the one contained in the previous RegistrationNotification INVOKE.

Regardless of whether or not a VLR entry exists for the MS, the VLR will send a RegistrationNotification INVOKE to the HLR for all premature autonomous registrations which occur on border cells. If authentication is active, the VLR will treat the RegistrationNotification as if it were the initial registration within the domain of the VLR and authenticate the MS using the procedures outlined in this Standard or *TSB51*.

1 If scenario 2 occurs on a border cell, the fact that the VLR sends the HLR a
 2 RegistrationNotification will enhance the HLR's ability to determine which of the MSCs
 3 which detected the MS's registration is the true serving system. If scenarios 3 or 4 occur on
 4 a border cell, the result will simply be a redundant transmission of a
 5 RegistrationNotification INVOKE to the HLR.
 6

7 8 9 **F.2 TIMER METHOD TO DETECT DUPLICATE** 10 **REGISTRATIONNOTIFICATION** 11

12 The HLR will initiate a timer (typically 3 seconds) upon the arrival of a
 13 RegistrationNotification INVOKE if the timer is not already running due to the arrival of a
 14 previous RegistrationNotification message within the timer period. Upon arrival of the first
 15 RegistrationNotification INVOKE, the HLR will also copy the old serving system
 16 information into a temporary scratch pad buffer and copy the parameters received in the
 17 RegistrationNotification INVOKE into the HLR.
 18

19
20 If another RegistrationNotification arrives while the timer is active, the HLR will compare
 21 the ReceivedSignalQuality and ControlChannelData parameters of the current
 22 RegistrationNotification message with the values stored in the HLR database. If the channel
 23 data indicates the same control channel the HLR will perform a signal quality comparison,
 24 if possible. If the ReceivedSignalQuality of the current RegistrationNotification is greater
 25 than that stored in the HLR, the VLR identification stored in the HLR will be sent a
 26 RegistrationNotification RETURN RESULT containing a new AuthorizationDenied and
 27 ControlChannelData parameters. The parameters reported by the current
 28 RegistrationNotification will then be stored in the HLR.
 29

30
31 If the ReceivedSignalQuality of the current RegistrationNotification is less than the value
 32 stored in the HLR, the VLR which sent the current RegistrationNotification INVOKE will
 33 be sent a RegistrationNotification RETURN RESULT with the AuthorizationDenied,
 34 ReceivedSignalQuality and ControlChannelData values stored in the HLR.
 35

36 When the RegistrationNotification timer expires, a RegistrationCancellation INVOKE is
 37 sent to the old serving VLR (identified in the scratch pad buffer) with the
 38 ReceivedSignalQuality value, if stored in the HLR, as an INVOKE parameter. If a
 39 RegistrationCancellation RETURN RESULT response without the CancellationDenied
 40 parameter is received back from the old serving VLR, the HLR will send a
 41 RegistrationNotification RETURN RESULT response to the VLR identification stored in
 42 the HLR. If a RegistrationCancellation RETURN RESULT with the CancellationDenied
 43 parameter is received from the old serving VLR, the HLR will send a
 44 RegistrationNotification RETURN RESULT with the AuthorizationDenied parameter set to
 45 the VLR identification stored in the HLR. The ReceivedSignalQuality value reported in the
 46 RegistrationCancellation RETURN RESULT and ControlChannelData will also be
 47 included. The old serving system information stored in the scratch pad buffer will then be
 48 copied back into the HLR database
 49

50 In order to better demonstrate the system's behavior, we expand the case to a registration
 51 access detected by two neighboring systems (figure 30).
 52

53 We assume that the old serving system receives the registration access with the best signal
 54 strength. The old serving system will then keep serving the MS:
 55

- 56 a. MSC-1 (the old serving system) receives a registration access from the MS with a
 57 signal strength value of ReceivedSignalQuality.
 58
 59
 60

- b. MSC-1 sends a RegistrationNotification INVOKE to VLR-1. Since the MS is already registered in this system, it does not send a RegistrationNotification INVOKE to the HLR. However, it internally marks the registration time, and stores the signal strength value of the registration request.
- c. VLR-1 accepts the registration by sending a RegistrationNotification RETURN RESULT to MSC-1.
- d. A neighboring system (MSC-2) overhears the same registration access. It sends a RegistrationNotification INVOKE with ReceivedSignalQuality and ControlChannelData to VLR-2.
- e. VLR-2 forwards the RegistrationNotification INVOKE to the HLR associated to the MS. The HLR starts a multiple access timer (typically 3 seconds).
- f. Another neighboring system (MSC-3) overhears the same registration access. It also sends a RegistrationNotification INVOKE with ReceivedSignalQuality and ControlChannelData to VLR-3.
- g. VLR-3 forwards the RegistrationNotification INVOKE to the HLR associated to the MS.
- h. While the multiple access timer is running, the ReceivedSignalQuality received with all RegistrationNotifications will be compared. The best will be kept in the HLR, the other will be sent a RegistrationNotification RETURN RESULT with the AuthorizationDenied parameter and ControlChannelData to indicate that their access was invalid.
- In our example the HLR determines that system #3 received signal strength is lower than system #2. It sends a RegistrationNotification RETURN RESULT with AuthorizationDenied, ReceivedSignalQuality and, ControlChannelData parameters to system #3.
- i. VLR-3 forwards the RegistrationNotification RETURN RESULT to MSC-3.
- j. When the multiple access timer expires,...
- k. ... the HLR sends a RegistrationCancellation INVOKE with the best received ReceivedSignalQuality and ControlChannelData parameters to system 1, the old serving system.
- l. The old serving system, by looking at the time stamp of the last received RegistrationNotification, determines that it received the same access.
- m. It compares MSC-2's signal strength received in the cancellation request from the HLR to the signal strength received in the last registration (received in step a). If the signal strength received from system #2 is the best, system #1 accepts the RegistrationCancellation.
- n. In our example the old serving system receives the best signal strength. It sends to the HLR a RegistrationCancellation RETURN RESULT with the CancellationDenied, ReceivedSignalQuality and ControlChannelData parameters to indicate that it denies the cancellation request.
- o. The HLR sends a RegistrationNotification RETURN RESULT with AuthorizationDenied, ReceivedSignalQuality and ControlChannelData to system #2 to indicate that it denies its registration.
- p. VLR-2 forwards the RegistrationNotification RETURN RESULT to MSC-2.

1
2
3
4
5
6
7
8
9
10
11
12
13
14
15
16
17
18
19
20
21
22
23
24
25
26
27
28
29
30
31
32
33
34
35
36
37
38
39
40
41
42
43
44
45
46
47
48
49
50
51
52
53
54
55
56
57
58
59
60

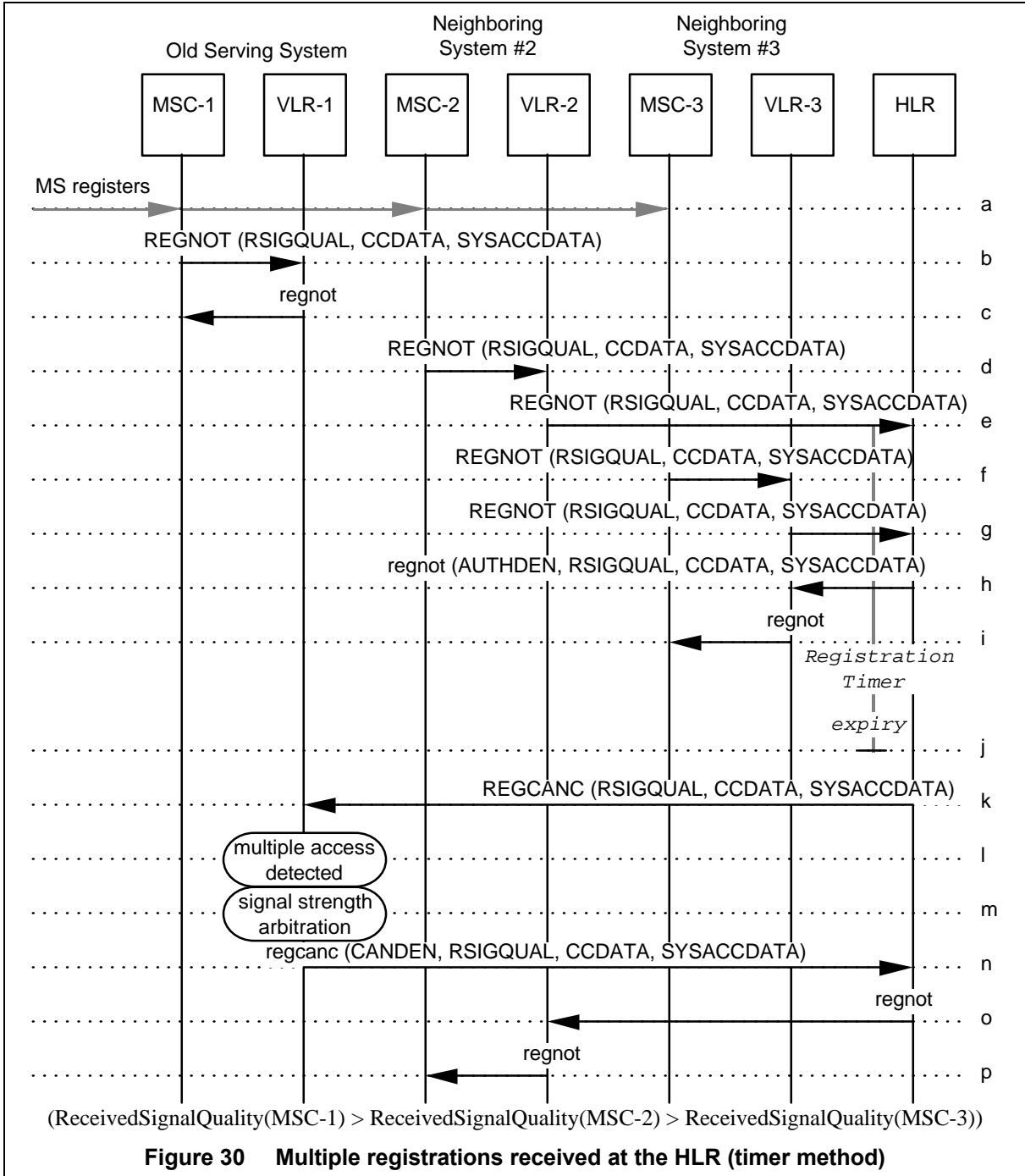

F.3 TIME STAMP METHOD TO DETECT DUPLICATE REGISTRATIONNOTIFICATION

The HLR will time stamp the arrival of all RegistrationNotification INVOKE messages. Whenever a RegistrationNotification message is received, the HLR will compare the time stamp of the RegistrationNotification with the time stamp of the previous

RegistrationNotification INVOKE. If the time difference is greater than 2 seconds, the HLR will assume that the MS has registered in a new serving system. The HLR will store the RegistrationNotification parameters in the HLR database and send a RegistrationCancellation INVOKE to the old serving VLR.

If the time difference between the current and previous RegistrationNotification is less than 2 seconds, the HLR will use the ReceivedSignalQuality parameter, if available, to determine whether the current or previous RegistrationNotification INVOKE came from the true serving VLR. If the ReceivedSignalQuality parameter of the current RegistrationNotification is greater than the value stored in the HLR database, the HLR will send a RegistrationCancellation INVOKE to the old serving VLR and store the current RegistrationNotification parameters in the HLR database. Whenever a RegistrationCancellation INVOKE is sent to the old serving VLR, the ReceivedSignalQuality value and ControlChannelData reported by the current RegistrationNotification message will be sent as RegistrationCancellation INVOKE parameters. If the ReceivedSignalQuality parameter stored in the HLR is greater than that of the current RegistrationNotification the HLR will send a RegistrationNotification RETURN RESULT with the AuthorizationDenied parameter set to the VLR which sent the current RegistrationNotification.

Since a VLR may reply to a RegistrationCancellation message with a CancellationDenied parameter, it is important for the HLR to save a copy of the old serving VLR information in a scratch pad buffer before overwriting the HLR with the current RegistrationNotification parameters so that the old serving VLR information can be restored into the HLR database if necessary. If the HLR receives a RegistrationCancellation RETURN RESULT with the CancellationDenied parameter, the HLR will store the ReceivedSignalQuality, if available, reported by the RETURN RESULT.

In order to better demonstrate the system's behavior, we expand the case to a registration access detected by two neighboring systems. See figure 31.

Assuming that neither neighboring system receives the MS with the best signal strength, the old serving system will continue to serve the MS:

- a. MSC-1 (the old serving system) receives a registration access from the MS with a signal strength value of ReceivedSignalQuality.
- b. MSC-1 sends a RegistrationNotification INVOKE to VLR-1. Since the MS is already registered in this system, it does not send a RegistrationNotification INVOKE to the HLR. However, it internally marks the registration time, and stores the signal strength value of the registration request.
- c. VLR-1 accepts the registration by sending a RegistrationNotification RETURN RESULT to MSC-1.
- d. A neighboring system (MSC-2) overhears the same registration access. It sends a RegistrationNotification INVOKE with ReceivedSignalQuality and ControlChannelData to VLR-2.
- e. VLR-2 forwards the RegistrationNotification INVOKE to the HLR associated to the MS. The HLR marks the time of reception.
- f. The HLR sends a RegistrationCancellation INVOKE with the ReceivedSignalQuality and ControlChannelData parameters to the old serving system VLR-1.
- g. The old serving system determines that it is a multiple access.

1
2
3
4
5
6
7
8
9
10
11
12
13
14
15
16
17
18
19
20
21
22
23
24
25
26
27
28
29
30
31
32
33
34
35
36
37
38
39
40
41
42
43
44
45
46
47
48
49
50
51
52
53
54
55
56
57
58
59
60

- h. VLR-2 determines that the reported ReceivedSignalQuality is not better than the one received from MSC-1.
- i. It denies the cancellation, by sending in the RegistrationCancellation RETURN RESULT to the HLR the CancellationDenied, ReceivedSignalQuality and ControlChannelData parameters it received from MSC-1.
- j. The HLR updates its stored values of ReceivedSignalQuality and denies the registration from system #2 by sending a RegistrationNotification RETURN RESULT that includes the AuthorizationDenied, ReceivedSignalQuality and ControlChannelData parameters from system #1.
- k. VLR-2 forwards the RegistrationNotification RETURN RESULT to MSC-1.
- l. A neighboring system (MSC-3) overhears the same registration access. It sends a RegistrationNotification INVOKE with ReceivedSignalQuality and ControlChannelData to VLR-3.
- m. VLR-3 forwards the RegistrationNotification INVOKE to the HLR.
- n. If it is received within 2 seconds of the last registration, the HLR compares the reported ReceivedSignalQuality with the value stored in its data base. Since the signal strength reported by system #1 is stronger than the one of system #3, the HLR denies the registration by sending a RegistrationNotification RETURN RESULT with the AuthorizationDenied, ReceivedSignalQuality and ControlChannelData parameters from system #1.
- o. VLR-3 forwards the RegistrationNotification RETURN RESULT to MSC-3.

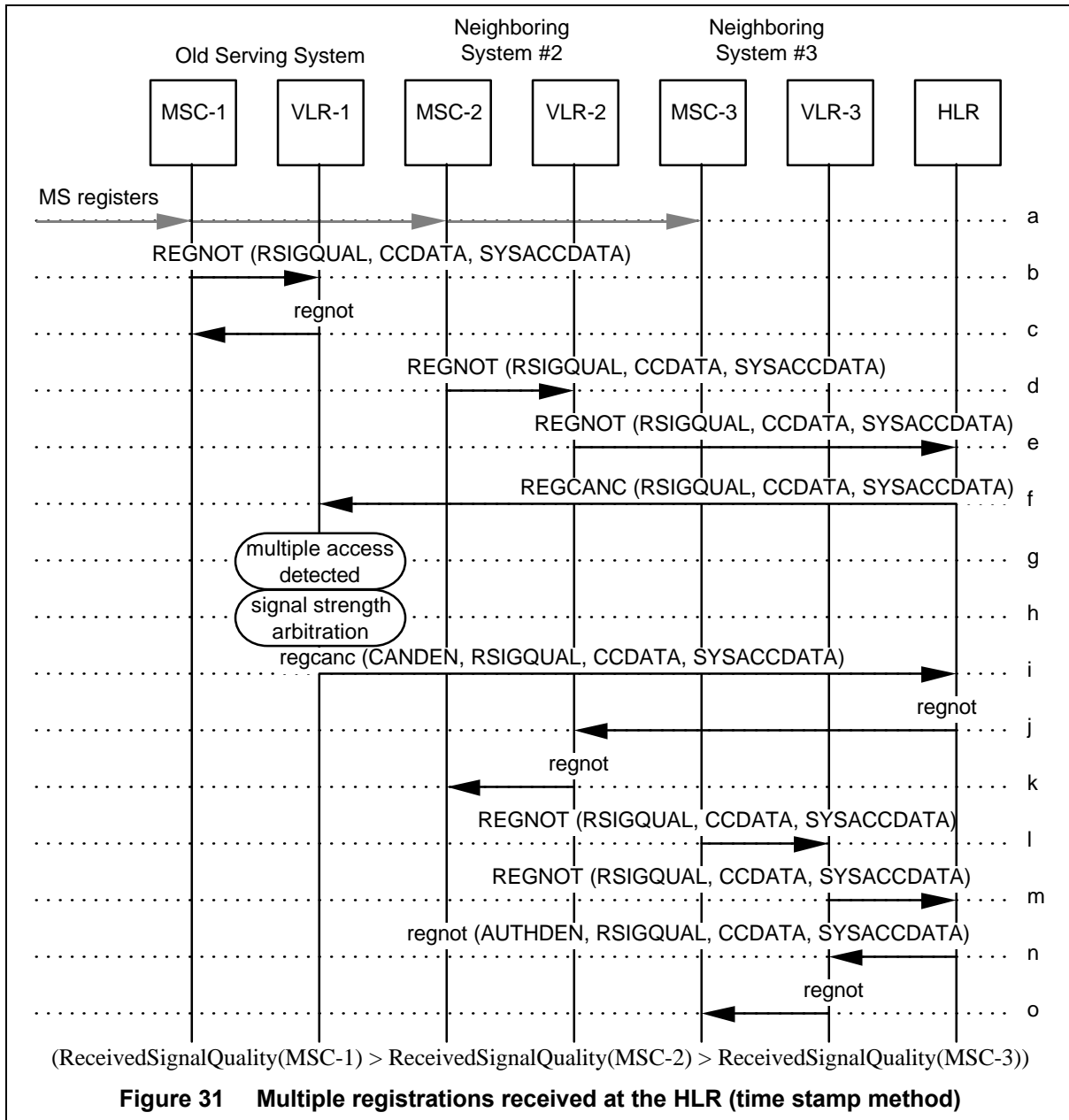

1
2
3
4
5
6
7
8
9
10
11
12
13
14
15
16
17
18
19
20
21
22
23
24
25
26
27
28
29
30
31
32
33
34
35
36
37
38
39
40
41
42
43
44
45
46
47
48
49
50
51
52
53
54
55
56
57
58
59
60

第2版作成協力者(2000年3月22日現在)

(敬称略)

第六部門委員会

| | | |
|-----------|-------|------------------------------|
| 部門委員長 | 山本 浩治 | N T T 移動通信網 (株) |
| 副部門委員長 | 大橋 正良 | K D D (株) |
| 副部門委員長 | 守田 直哉 | 松下通信工業 (株) |
| 委員 | 宮川 澄夫 | シーメンス(株) |
| 委員 | 竹内 崇夫 | モトローラ (株) |
| 委員 | 若林 清久 | ノキア・ジャパン(株) |
| 委員 | 小寺 隆三 | カールコム ジャパン(株) |
| 委員 | 高畠 達美 | WG6-1 委員長・日本電気 (株) |
| 委員 | 澤田 寛 | WG6-1 副委員長・N T T 移動通信網 (株) |
| 委員 | 山崎 吉一 | WG6-1 副委員長・日本移動通信 (株) |
| 委員 | 栗林 伸一 | WG6-2 副委員長・日本電信電話 (株) |
| 委員 | 大内 敏哉 | WG6-2 副委員長・(株)日立製作所 |
| 委員 | 平松 幸男 | WG6-3 委員長・日本電信電話 (株) |
| 委員 | 椎野 創 | WG6-3 副委員長・日本ルセント・テクノロジー-(株) |
| 委員 | 加藤 正文 | WG6-3 副委員長・富士通 (株) |
| 委員 | 中村 寛 | WG6-4 委員長・N T T 移動通信網 (株) |
| 委員 | 村中 俊文 | WG6-4 副委員長・沖電気工業 (株) |
| 委員 | 松井 進 | WG6-4 副委員長・(株)日立製作所 |
| 委員 | 吉村 隆之 | WG6-5 委員長・日本テレコム (株) |
| 委員 | 林 健太郎 | WG6-5 副委員長・沖電気工業 (株) |
| 委員 | 住田 正臣 | WG6-5 副委員長・日本エリクソン (株) |
| 委員 | 小山 正弘 | WG6-6 委員長・富士通 (株) |
| 委員 | 石原 正和 | WG6-6 副委員長・日本電気 (株) |
| 委員 | 工藤 理夫 | WG6-6 副委員長・第二電電 (株) |
| 委員 | 大宮 知己 | WG6-7 委員長・日本電信電話 (株) |
| 委員 | 鈴木 昌哉 | WG6-7 副委員長・富士通 (株) |
| 委員 | 牧平 経市 | WG6-7 副委員長・三菱電機 (株) |
| T T C 事務局 | 芳野 敬二 | 第六技術部 |

(敬称略)

第六部門委員会 **第七専門委員会**

| | | |
|--------|--------|------------------------------------|
| 専門委員長 | 大宮 知己 | 日本電信電話(株) |
| 副専門委員長 | 鈴木 昌哉 | 富士通(株) |
| 副専門委員長 | 牧平 経市 | 三菱電機(株) |
| 委員 | 大野 光敏 | KDD(株) |
| 委員 | 島 英徳 | 第二電電(株) |
| 委員 | 東海林 尚美 | 東京通信ネットワーク(株) |
| 委員 | 光武 雄一郎 | 日本テレコム(株) |
| 委員 | 黒川 章 | SWG3 リーダ [®] ・日本電信電話(株) |
| 委員 | 石崎 長俊 | SWG1 リーダ [®] ・NTT移動通信網(株) |
| 委員 | 山田 博 | ジェイフォン東京(株) |
| 委員 | 酒井 健次 | 中部テレコムコミュニケーション(株) |
| 委員 | 黒木 政克 | (株)ツーカーセルラー東京 |
| 委員 | 國本 佳彦 | (株)ツーカーホン関西 |
| 委員 | 紺谷 武夫 | 日本移動通信(株) |
| 委員 | 近 義起 | DDIポケット(株) |
| 委員 | 森脇 順二 | (株)アステル関西 |
| 委員 | 高橋 秀夫 | アンリツ(株) |
| 委員 | 浅岡 浩二 | 岩崎通信機(株) |
| 委員 | 成田 豊登 | 沖電気工業(株) |
| 委員 | 高橋 匠 | キヤノン(株) |
| 委員 | 横田 知好 | 京セラ(株) |
| 委員 | 橋爪 聡司 | 国際電気(株) |
| 委員 | 井原 茂雄 | シャープ(株) |
| 委員 | 亀村 昭寛 | 住友電気工業(株) |
| 委員 | 滝口 盛夫 | (株)大興電機製作所 |
| 委員 | 鈴木 弘一 | (株)東芝 |
| 委員 | 長谷川 茂夫 | 日本ルセント・テクノロジー(株) |
| 委員 | 阿部 正一 | 日本電気(株) |
| 委員 | 樋山 憲夫 | 日本ビクター(株) |
| 委員 | 境 穰 | 日本無線(株) |
| 委員 | 神尾 勉 | モトローラ(株) |
| 委員 | 東 孝昭 | (株)日立製作所 |
| 委員 | 木田 哲昭 | 富士通(株) |
| 特別専門委員 | 野田 昭繁 | SWG2 リーダ [®] ・富士通(株) |
| 委員 | 両角 昌英 | 松下通信工業(株) |

| | | |
|--------|-------|--------------------|
| 委員 | 松高 靖 | 三菱電機（株） |
| 特別専門委員 | 今井 毅 | SWG4 リーダ*・三菱電機（株） |
| 委員 | 木村 恵治 | 明星電気（株） |
| 委員 | 関口 英生 | Iマ・テイ・テイ・ソフトウェア（株） |
| 委員 | 小池 剛 | 日本エリクソン（株） |
| 委員 | 山下 哲一 | （株）デンソー |
| 委員 | 佐藤 孝一 | 日本情報通信コンサルティング*（株） |
| 委員 | 吉本 孔史 | 日本船舶通信（株） |

ＪＪ - 70 . 1 1 検討グループ

| | | |
|-----|-------|-----------------|
| リーダ | 工藤 理夫 | 第二電電（株） |
| 委員 | 大野 光敏 | KDD（株） |
| 委員 | 新島 登 | 第二電電（株） |
| 委員 | 島 英徳 | 第二電電（株） |
| 委員 | 鈴木 克典 | 第二電電（株） |
| 委員 | 三好 純一 | 日本テレコム（株） |
| 委員 | 丸山 裕二 | 日本移動通信（株） |
| 委員 | 三澤 康巨 | 日本移動通信（株） |
| 委員 | 深山 雅庸 | 日本ルセントテクノロジー（株） |
| 委員 | 武重 幸男 | 日本電気（株） |
| 委員 | 一色 宏文 | モトローラ（株） |
| 委員 | 竹内 崇夫 | モトローラ（株） |
| 委員 | 白井 啓介 | （株）日立製作所 |
| 委員 | 嘉村 健 | 富士通（株） |