

TTC標準
Standard

JF-IETF-RFC3398

SIP-TTC ISUP 信号方式相互接続に関する技術仕様

Technical Specification on SIP to TTC ISUP Interworking

第 1.0 版

2005 年 6 月 2 日

社団法人
情報通信技術委員会

THE TELECOMMUNICATION TECHNOLOGY COMMITTEE



1. 本書は RFC3388 英原文を転載しています。RFC3398 の著作権は Internet Society が保有しています。

RFC3398 著作権事項

Copyright (C) The Internet Society (2002). All Rights Reserved.

This document and translations of it may be copied and furnished to others, and derivative works that comment on or otherwise explain it or assist in its implementation may be prepared, copied, published and distributed, in whole or in part, without restriction of any kind, provided that the above copyright notice and this paragraph are included on all such copies and derivative works. However, this document itself may not be modified in any way, such as by removing the copyright notice or references to the Internet Society or other Internet organizations, except as needed for the purpose of developing Internet standards in which case the procedures for copyrights defined in the Internet Standards process must be followed, or as required to translate it into languages other than English.

The limited permissions granted above are perpetual and will not be revoked by the Internet Society or its successors or assigns.

This document and the information contained herein is provided on an "AS IS" basis and THE INTERNET SOCIETY AND THE INTERNET ENGINEERING TASK FORCE DISCLAIMS ALL WARRANTIES, EXPRESS OR IMPLIED, INCLUDING BUT NOT LIMITED TO ANY WARRANTY THAT THE USE OF THE INFORMATION HEREIN WILL NOT INFRINGE ANY RIGHTS OR ANY IMPLIED WARRANTIES OF MERCHANTABILITY OR FITNESS FOR A PARTICULAR PURPOSE.

2. 本書における RFC3398 原英文以外の部分については、(社) 情報通信技術委員会が著作権を保有しています。

(社) 情報通信技術委員会が著作権を保有する部分の一部又は全部を(社) 情報通信技術委員会の許諾を得ることなく複製、転載、改変、転用及びネットワーク上での送信、配布を行うことを禁止します。

目次

<参考>	4
1.1 概要	7
1.1.1 本標準の内容	7
1.1.2 本標準における留意点	7
1.1.3 本標準の記述方式について	7
1.2 参照文献	7
0. RFC3398 の前文	9
1. Introduction	11
2. Scope	12
3. Terminology	13
4. Scenarios	13
5. SIP Mechanisms Required	16
5.1 'Transparent' Transit of ISUP Messages	16
5.2 Understanding MIME Multipart Bodies	16
5.3 Transmission of Dual-Tone Multifrequency (DTMF) Information	17
5.4 Reliable Transmission of Provisional Responses	17
5.5 Early Media	17
5.6 Mid-Call Transactions which do not change SIP state	18
5.7 Privacy Protection	18
5.8 CANCEL causes	20
6. Mapping	20
7. SIP to ISUP Mapping	21
7.1 SIP to ISUP Call flows	21
7.1.1 En-bloc Call Setup (no auto-answer)	21
7.1.2 Auto-answer call setup	23
7.1.3 ISUP T7 Expires	24
7.1.4 SIP Timeout	25
7.1.5 ISUP Setup Failure	27
7.1.6 Cause Present in ACM Message	28
7.1.7 Call Canceled by SIP	30
7.2 State Machine	31
7.2.1 INVITE received	32
7.2.1.1 INVITE to IAM procedures	32
7.2.2 ISUP T7 expires	39
7.2.3 CANCEL or BYE received	39
7.2.4 REL received	41
7.2.4.1 ISDN Cause Code to Status Code Mapping	41
7.2.5 Early ACM received	45
7.2.6 ACM received	45
7.2.7 CON or ANM Received	47
7.2.8 Timer T9 Expires	48
7.2.9 CPG Received	48

7.3	ACK received	49
8.	ISUP to SIP Mapping	49
8.1	ISUP to SIP Call Flows	49
8.1.1	En-bloc call setup (non auto-answer)	50
8.1.2	Auto-answer call setup	51
8.1.3	SIP Timeout	52
8.1.4	ISUP T9 Expires	53
8.1.5	SIP Error Response	54
8.1.6	SIP Redirection	55
8.1.7	Call Canceled by ISUP	56
8.2	State Machine	58
8.2.1	Initial Address Message received	59
8.2.1.1	IAM to INVITE procedures	60
8.2.2	100 received	61
8.2.3	18x received	61
8.2.4	2xx received	63
8.2.5	3xx Received	65
8.2.6	4xx-6xx Received	65
8.2.6.1	SIP Status Code to ISDN Cause Code Mapping	66
8.2.7	REL Received	68
8.2.8	ISUP T11 Expires	68
9.	Suspend/Resume and Hold	69
9.1	Suspend (SUS) and Resume (RES) Messages	69
9.2	Hold (re-INVITE)	71
10.	Normal Release of the Connection	71
10.1	SIP initiated release	72
10.2	ISUP initiated release	73
10.2.1	Caller hangs up	73
10.2.2	Callee hangs up (SUS)	74
11.	ISUP Maintenance Messages	74
11.1	Reset messages	74
11.2	Blocking messages	75
11.3	Continuity Checks	75
12.	Construction of Telephony URIs	77
12.1	ISUP format to tel URL mapping	79
12.2	tel URL to ISUP format mapping	81
13.	Other ISUP flavors	83
13.1	Guidelines for sending other ISUP messages	83
14.	Acronyms	85
15.	Security Considerations	85
16.	IANA Considerations	89
17.	Acknowledgments	89
18.	Normative References	89

19. Non-Normative References	90
Authors' Addresses	92
Full Copyright Statement	93
付属資料 a. ISUP メッセージ設定値	94
a. 1. アドレスメッセージ (IAM)	94
a. 2. アドレス完了メッセージ (ACM), 応答メッセージ (ANM)	95
付属資料 b. ISDN アクセス表示 (ISDN/非 ISDN) に関する留意点	96
b. 1. 本付属資料の目的	96
b. 2. パラメータ設定に関する留意事項	96
b. 2. 1. 非 ISDN を明示する場合	96
b. 2. 2. ユーザ・ユーザ情報要求への対応	96
b. 2. 3. ISDN 固有サービスへの対応	96
付録 i ISUP 発 SIP 着における逆方向パス接続に関する留意点について	97
付録 ii JF-IETF-RFC3398 と ITU-T 勧告 Q.1912.5 との差分について	98

<参考>

1. 国際勧告等との関係

本標準は、IETFにおいて制定されたRFC3398をベースとしている。

IETF RFC3398を国内に適用するために、国内での通信事情を考慮した用法について記述している。ただし、RFC3398を拡張するものではない。

2. 上記国際勧告等に対する追加項目等

(1) RFC3398の下記の部分に対して、記述を追加している。具体的な内容については本標準本文を参照のこと。

4. Scenarios

5.1 'Transparent' Transit of ISUP Messages

5.5 Early Media

5.7 Privacy Protection

7.1.1 En-bloc Call Setup (no auto-answer)

7.1.2 Auto-answer call setup

7.1.3 ISUP T7 Expires

7.1.4 SIP Timeout

7.1.6 Cause Present in ACM Message

7.2 State Machine

7.2.1.1 INVITE to IAM procedures

7.2.2 ISUP T7 expires

7.2.4.1 ISDN Cause Code to Status Code Mapping

7.2.6 ACM received

7.2.7 CON or ANM Received

7.2.8 Timer T9 Expires

7.2.9 CPG Received

8.1.2 Auto-answer call setup

8.1.4 ISUP T9 Expires

8.2 State Machine

8.2.1.1 IAM to INVITE procedures

8.2.3 18x received

8.2.4 2xx received

8.2.6.1 SIP Status Code to ISDN Cause Code Mapping

9.1 Suspend (SUS) and Resume (RES) Messages

9.2 Hold (re-INVITE)

10.2.2 Callee hangs up (SUS)

11.3. Continuity Checks

12. Construction of Telephony URIs

12.1 ISUP format to tel URL mapping

12.2 tel URL to ISUP format mapping

13. Other ISUP flavors

13.1 Guidelines for sending other ISUP messages

15. Security Considerations

(2) ISUP メッセージ設定値(付属資料 a)、 ISDN アクセス表示(ISDN/非 ISDN)に関する留意点(付属資料 b)、 ISUP 発 SIP 着における逆方向パス接続に関する留意点について(付録 i)、 JF-IETF-RFC3398 と ITU-T 勧告 Q.1912.5 との差分について(付録 ii)を追加している。

(3) RFC3398 との章立ての構成比較表

RFC3398 との章立ての構成の相違を下表に示す。

RFC3398	本標準
—	<参考> I.1 概要 I.2 参考文献
State of this Memo Copyright Notice Abstract Table of Contents	0. RFC3398 の前文
1. Introduction	1. Introduction
2. Scope	2. Scope
3. Terminology	3. Terminology
4. Senarios	4. SIP Mechansms Required
5. SIP Mechansms Required	5. SIP Mechansms Required
6. Mapping	6. Mapping
7. SIP to ISUP Mapping	7. SIP to ISUP Mapping
8. ISUP to SIP Mapping	8. ISUP to SIP Mapping
9. Suspend/Resume and Hold	9. Suspend/Resume and Hold
10. Normal Release of the Connection	10. Normal Release of the Connection
11. ISUP Maintenance Messages	11. ISUP Maintenance Messages
12. Construction of Telephony URIs	12. Construction of Telephony URIs
13. Other ISUP flavors	13. Other ISUP flavors
14. Acronyms	14. Acronyms
15. Security Considerations	15. Security Considerations
16. IANA Considerations	16. IANA Considerations
17. Acknowledgments	17. Acknowledgments
18. Normative References	18. Normative References
19. Non-Normative References Authors' Addresses Authors' Addresses	19. Non-Normative References Authors' Addresses Authors' Addresses
—	付属資料 a. ISUP メッセージ設定値 付属資料 b. ISDN アクセス表示(ISDN/非 ISDN)に関する留意点 付録 i ISUP 発 SIP 着における逆方向パス接続に関する留意点について 付録 ii JF-IETF-RFC3398 と ITU 勧告 Q.1912.5 との差分について

3. 改版の履歴

版数	制定日	改版内容
第 1.0 版	2005 年 6 月 2 日	初版制定 (TS-1002 第 2 版の TTC 標準への格上げ) TS-1002 からの主な改版内容は以下の通り。 ・ 文書フォーマットの変更 (原文の囲み枠と Copyright 追加、段落内注記時の分割挿入) ・ ISUP⇄SIP 信号のマッピング条件に関する記述を追加/変更 ・ 付録 ii を追加

4. 工業所有権

TTC の「工業所有権等の実施の権利に係る確認書」の提出状況は、TTC ホームページで公開されている。

5. その他

(1) 参照する主な勧告、標準

IETF RFC: RFC3261, RFC3398

TTC 標準: JT-Q763 (2002/5/30), JT-Q764 (2002/5/30), JT-Q850 (1996/11/27), JJ-90.10 (2001/11/27),
JT-Q699 (2000/11/30), JJ-90.21 (2005/6/2), JJ-90.22 (2005/6/2)

ITU-T 勧告: Q.764 (2000/12), Q.1912.5(2004/3)

6. 標準作成部門

信号制御専門委員会

1.1 概要

本標準は、SIP (SIP: Session Initiation Protocol)[1]とTTC標準で規定されるISUP信号方式(JT-Q761-764)とのシグナリングインタワークにおいて、特別の考慮が必要な事項について規定するものである。

1.1.1 本標準の内容

本標準の記述する内容は以下の通りである。

- SIPとISUPのインタワークに関してIETFで制定されたRFC3398[2]に対して、TTC ISUP[3][4]に適用する場合に考慮すべき差分事項について記述する。
- 事業者間の相互接続用共通インタフェース[6]で規定される内容との完全なインタワークについては、本標準の範囲外とするが、基本接続の範囲において考慮が必要な事項について参考情報を記述する。

1.1.2 本標準における留意点

本標準においては次の点に対して留意が必要である。

- 本標準におけるベアラに関しては、“音声”もしくは“3.1KHz オーディオ”にその範囲を限定するものとする。
- 本標準においては、各種付加サービス呼(呼転送、ナンバーポータビリティ等)は検討の範囲外とする。
- 本標準におけるTTC特有事項に関する部分について、その接続形態は、PSTN-SIP網間の相互接続のみを範囲としており、PSTN-SIP網-PSTN (“SIP Bridging”のケース)は範囲外としている。
- 本標準におけるMGCの動作規定は、JJ-90.21[9]におけるインタフェースCのバウンダリの動作に適用される。
- 本標準においては、事業者間料金精算方式に関する事項は検討の範囲外とするが、ISUPのパラメータ設定上において事業者間料金精算方式検討会や各事業者間の整理に従う必要があることに留意すること。

1.1.3 本標準の記述方式について

本標準では、RFCの英原文[2]に対し、TTC ISUP [3][4]および相互接続用共通インタフェース[6]とインタワークのために差分が生じる箇所について開始部を▼、終了部を▲の記号で示し、その差分規定を該当する箇所の後に日本語で挿入する記述形式とする。また、章節全体に該当して記述が必要な内容については、章節のタイトルの直後に差分規定を記述するものとする。

なお、相互接続用共通インタフェース[6]との接続において特に考慮が必要となる事項については、(JJ-90.10注)を段落の始めに付記して注釈を追記する。

英原文[2]は枠で囲み、Copyrightを囲み枠の外に付記する。

1.2.参照文献

- [1] "SIP: セッション開始プロトコル(Session Initiation Protocol)", TTC 標準 JF-IETF-RFC3261 第1版, 情報通信技術委員会(The Telecommunication Technologies Committee), 2005年6月.
- [2] "Integrated Services Digital Network (ISDN) User Part (ISUP) to Session Initiation Protocol (SIP) Mapping", RFC3398, December 2002
- [3] "フォーマットおよびコード(ISUP formats and codes)", TTC 標準 JT-Q763, 情報通信技術委員会(The Telecommunication Technologies Committee), 2002年5月
- [4] "ISUP 信号手順(ISUP signalling procedures)", TTC 標準 JT-Q764, 情報通信技術委員会(The Telecommunication Technologies Committee), 2002年5月.
- [5] "デジタル加入者線信号方式No.1 (DSS1) およびNo.7信号方式 ISDN ユーザ部(ISUP)における理由表

示の使用法および生成源(Usage of Cause and Location in the Digital Subscriber Signalling System No.1 and the Signalling System No.7 ISDN User Part) ", TTC 標準 JT-Q850 , 電信電話技術委員会(The Telecommunication Technologies Committee), 1996年11月.

- [6] "相互接続共通インタフェース仕様(Inter-Carrier Interface based on ISUP)", TTC 標準 JJ-90.10 第6版, 情報通信技術委員会(The Telecommunication Technologies Committee), 2003年4月
- [7] "SS7 ISDN User Part signalling procedures" , ITU-T Q.764 , December 2000
- [8] " No.7 信号方式の ISDN ユーザ部を介した ISDN アクセスや非 ISDN アクセスのインタワーキング (Interworking between ISDN access and non-ISDN access over ISDN User Part of signalling system No.7)", TTC 標準 JT-Q699 , 情報通信技術委員会(The Telecommunication Technologies Committee), 情報通信技術委員会(The Telecommunication Technologies Committee), 2000年11月.
- [9] "事業者 SIP 網に関するフレームワーク技術仕様(Technical Specification of the framework on Provider's SIP Networks)", TTC 標準 JJ-90.21 第1版, 情報通信技術委員会(The Telecommunication Technologies Committee), 2005年6月.
- [10] "事業者 SIP 網における網付与ユーザ ID 情報転送に関する技術仕様(Technical Specification on Network Asserted User Identity Information Transferring through Provider's SIP Networks)", TTC 標準 JJ-90.22 第1版, 情報通信技術委員会(The Telecommunication Technologies Committee), 2005年6月.
- [11] "セッション開始プロトコル(SIP)のための Reason ヘッダフィールド(The Reason Header Field for the Session Initiation Protocol (SIP))", TTC 標準 JF-IETF-RFC3326, 情報通信技術委員会 (The Telecommunication Technologies Committee), 2005年6月.
- [12] "管理された事業者 SIP 網間における相互接続インタフェース技術仕様 (Technical Specifications on Inter-Carrier Interface between Managed Provider's SIP Networks)", TTC 標準 JJ-90.25 第1版, 情報通信技術委員会(The Telecommunication Technologies Committee), 2005年6月.
- [13] "Interworking between Session Initiation Protocol (SIP) and Bearer Independent Call Control Protocol or ISDN User Part" , ITU-T Q.1912.5 , March 2004

その他RFC3398[2] 内で参照している勧告、標準については本文 18 章(Normative References)及び 19 章 (Non-Normative References)にて記述している。

0. RFC3398 の前文

Network Working Group
Request for Comments: 3398
Category: Standards Track

G. Camarillo
Ericsson
A. B. Roach
dynamicsoft
J. Peterson
NeuStar
L. Ong
Ciena
December 2002

Integrated Services Digital Network (ISDN) User Part (ISUP) to Session Initiation Protocol (SIP) Mapping

Status of this Memo

This document specifies an Internet standards track protocol for the Internet community, and requests discussion and suggestions for improvements. Please refer to the current edition of the "Internet Official Protocol Standards" (STD 1) for the standardization state and status of this protocol. Distribution of this memo is unlimited.

Copyright Notice

Copyright (C) The Internet Society (2002). All Rights Reserved.

Abstract

This document describes a way to perform the mapping between two signaling protocols: the Session Initiation Protocol (SIP) and the Integrated Services Digital Network (ISDN) User Part (ISUP) of Signaling System No. 7 (SS7). This mechanism might be implemented when using SIP in an environment where part of the call involves interworking with the Public Switched Telephone Network (PSTN).

Table of Contents

1.	Introduction.....	3
2.	Scope.....	4
3.	Terminology.....	5
4.	Scenarios.....	5
5.	SIP Mechanisms Required.....	7
5.1	'Transparent' Transit of ISUP Messages.....	7
5.2	Understanding MIME Multipart Bodies.....	7
5.3	Transmission of DTMF Information.....	8
5.4	Reliable Transmission of Provisional Responses.....	8
5.5	Early Media.....	8
5.6	Mid-Call Transactions which do not change SIP state....	9

5.7	Privacy Protection.....	9
5.8	CANCEL causes.....	10
6.	Mapping.....	10
7.	SIP to ISUP Mapping.....	11
7.1	SIP to ISUP Call flows.....	11
7.1.1	En-bloc Call Setup (no auto-answer).....	11
7.1.2	Auto-answer call setup.....	12
7.1.3	ISUP T7 Expires.....	13
7.1.4	SIP Timeout.....	14
7.1.5	ISUP Setup Failure.....	15
7.1.6	Cause Present in ACM Message.....	16
7.1.7	Call Canceled by SIP.....	17
7.2	State Machine.....	18
7.2.1	INVITE received.....	19
7.2.1.1	INVITE to IAM procedures.....	19
7.2.2	ISUP T7 expires.....	23
7.2.3	CANCEL or BYE received.....	23
7.2.4	REL received.....	24
7.2.4.1	ISDN Cause Code to Status Code Mapping.....	24
7.2.5	Early ACM received.....	27
7.2.6	ACM received.....	27
7.2.7	CON or ANM Received.....	28
7.2.8	Timer T9 Expires.....	29
7.2.9	CPG Received.....	29
7.3	ACK received.....	30
8.	ISUP to SIP Mapping.....	30
8.1	ISUP to SIP Call Flows.....	30
8.1.1	En-bloc call setup (non auto-answer).....	31
8.1.2	Auto-answer call setup.....	32
8.1.3	SIP Timeout.....	33
8.1.4	ISUP T9 Expires.....	34
8.1.5	SIP Error Response.....	35
8.1.6	SIP Redirection.....	36
8.1.7	Call Canceled by ISUP.....	37
8.2	State Machine.....	39
8.2.1	Initial Address Message received.....	39
8.2.1.1	IAM to INVITE procedures.....	40
8.2.2	100 received.....	41
8.2.3	18x received.....	41
8.2.4	2xx received.....	43
8.2.5	3xx Received.....	44
8.2.6	4xx-6xx Received.....	44
8.2.6.1	SIP Status Code to ISDN Cause Code Mapping.....	45
8.2.7	REL Received.....	47
8.2.8	ISUP T11 Expires.....	47
9.	Suspend/Resume and Hold.....	48
9.1	SUS and RES.....	48
9.2	Hold (re-INVITE).....	50

10.	Normal Release of the Connection.....	50
10.1	SIP initiated release.....	50
10.2	ISUP initiated release.....	51
10.2.1	Caller hangs up.....	51
10.2.2	Callee hangs up (SUS).....	52
11.	ISUP Maintenance Messages.....	52
11.1	Reset messages.....	52
11.2	Blocking messages.....	53
11.3	Continuity Checks.....	53
12.	Construction of Telephony URIs.....	54
12.1	ISUP format to tel URL mapping.....	56
12.2	tel URL to ISUP format mapping.....	57
13.	Other ISUP flavors.....	58
13.1	Guidelines for sending other ISUP messages.....	58
14.	Acronyms.....	60
15.	Security Considerations.....	60
16.	IANA Considerations.....	64
17.	Acknowledgments.....	64
18.	Normative References.....	64
19.	Non-Normative References.....	65
	Authors' Addresses.....	67
	Full Copyright Statement.....	68

1. Introduction

SIP [1] is an application layer protocol for establishing, terminating and modifying multimedia sessions. It is typically carried over IP. Telephone calls are considered a type of multimedia sessions where just audio is exchanged.

Integrated Services Digital Network (ISDN) User Part (ISUP) [12] is a level 4 protocol used in Signaling System No. 7 (SS7) networks. It typically runs over Message Transfer Part (MTP) although it can also run over IP (see SCTP [19]). ISUP is used for controlling telephone calls and for maintenance of the network (blocking circuits, resetting circuits etc.).

A module performing the mapping between these two protocols is usually referred to as Media Gateway Controller (MGC), although the terms 'softswitch' or 'call agent' are also sometimes used. An MGC has logical interfaces facing both networks, the network carrying ISUP and the network carrying SIP. The MGC also has some capabilities for controlling the voice path; there is typically a Media Gateway (MG) with E1/T1 trunking interfaces (voice from Public Switched Telephone Network - PSTN) and with IP interfaces (Voice over IP - VoIP). The MGC and the MG can be merged together in one physical box or kept separate.

These MGCs are frequently used to bridge SIP and ISUP networks so that calls originating in the PSTN can reach IP telephone endpoints and vice versa. This is useful for cases in which PSTN calls need to take advantage of services in IP world, in which IP networks are used as transit networks for PSTN-PSTN calls, architectures in which calls originate on desktop 'softphones' but terminate at PSTN terminals, and many other similar next-generation telephone architectures.

This document describes logic and procedures which an MGC might use to implement the mapping between SIP and ISUP by illustrating the correspondences, at the message level and parameter level, between the protocols. It also describes the interplay between parallel state machines for these two protocols as a recommendation for implementers to synchronize protocol events in interworking architectures.

2. Scope

This document focuses on the translation of ISUP messages into SIP messages, and the mapping of ISUP parameters into SIP headers. For ISUP calls that traverse a SIP network, the purpose of translation is to allow SIP elements such as proxy servers (which do not typically understand ISUP) to make routing decisions based on ISUP criteria such as the called party number. This document consequently provides a SIP mapping only for those ISUP parameters which might be used by intermediaries in the routing of SIP requests. As a side effect of this approach, translation also increases the overall interoperability by providing critical information about the call to SIP endpoints that cannot understand encapsulated ISUP, or perhaps which merely cannot understand the particular ISUP variant encapsulated in a message.

This document also only takes into account the call functionality of ISUP. Maintenance messages dealing with PSTN trunks are treated only as far as they affect the control of an ongoing call; otherwise these messages neither have nor require any analog in SIP.

Messages indicating error or congestion situations in the PSTN (MTP-3) and the recovery mechanisms used such as User Part Available and User Part Test ISUP messages are outside the scope of this document

There are several flavors of ISUP. International Telecommunication Union Telecommunication Standardization Sector (ITU-T) International ISUP [12] is used through this document; some differences with the American National Standards Institute (ANSI) [11] ISUP and the Telecommunication Technology Committee (TTC) ISUP are also outlined. ITU-T ISUP is used in this document because it is the most widely known of all the ISUP flavors. Due to the small number of fields

that map directly from ISUP to SIP, the signaling differences between ITU-T ISUP and specific national variants of ISUP will generally have little to no impact on the mapping. Note, however, that the ITU-T has not substantially standardized practices for Local Number Portability (LNP) since portability tends to be grounded in national numbering plan practices, and that consequently LNP must be described on a virtually per-nation basis. The number portability practices described in this document are presented as an optional mechanism.

Mapping of SIP headers to ISUP parameters in this document focuses largely on the mapping between the parameters found in the ISUP Initial Address Message (IAM) and the headers associated with the SIP INVITE message; both of these messages are used in their respective protocols to request the establishment of a call. Once an INVITE has been sent for a particular session, such headers as the To and From field become essentially fixed, and no further translation will be required during subsequent signaling, which is routed in accordance with Via and Route headers. Hence, the problem of parameter-to-header mapping in SIP-T is confined more or less to the IAM and the INVITE. Some additional detail is given in the population of parameters in the ISUP messages Address Complete Message (ACM) and Release Message (REL) based on SIP status codes

This document describes when the media path associated with a SIP call is to be initialized, terminated, modified, etc., but it does not go into details such as how the initialization is performed or which protocols are used for that purpose.

3. Terminology

In this document, the key words "MUST", "MUST NOT", "REQUIRED", "SHALL", "SHALL NOT", "SHOULD", "SHOULD NOT", "RECOMMENDED", "NOT RECOMMENDED", "MAY", and "OPTIONAL" are to be interpreted as described in RFC2119 [2] and indicate requirement levels for compliant SIP implementations.

4. Scenarios

There are several scenarios where ISUP-SIP mapping takes place. The way the messages are generated is different depending on the scenario.

When there is a single MGC and the call is from a SIP phone to a PSTN phone, or vice versa, the MGC generates the ISUP messages based on the methods described in this document.

```

+-----+      +-----+      +-----+
| PSTN switch +-----+ MGC +-----+ SIP UAC/UAS |
+-----+      +-----+      +-----+

```

From "RFC3398"
(C) The Internet
Society



The scenario where a call originates in the PSTN, goes into a SIP network and terminates in the PSTN again is known as "SIP bridging". SIP bridging should provide ISUP transparency between the PSTN switches handling the call. This is achieved by encapsulating the incoming ISUP messages in the body of the SIP messages (see [3]). In this case, the ISUP messages generated by the egress MGC are the ones present in the SIP body (possibly with some modifications; for example, if the called number in the request Uniform Resource Identifier - URI - is different from the one present in the ISUP due to SIP redirection, the ISUP message will need to be adjusted).

```

+-----+ +-----+ +-----+ +-----+ +-----+
| PSTN +-----+ Ingress MGC +-----+ SIP +-----+ Egress MGC +-----+ PSTN |
+-----+ +-----+ +-----+ +-----+ +-----+

```

SIP is used in the middle of both MGCs because the voice path has to be established through the IP network between both MGs; this structure also allows the call to take advantage of certain SIP services. ISUP messages in the SIP bodies provide further information (such as cause values and optional parameters) to the peer MGC.

From "RFC3398"
(C) The Internet
Society



本標準における TTC 特有部分の記述においては、“SIP Bridging”のケースについては範囲外としている。

In both scenarios, the ingress MGC places the incoming ISUP messages in the SIP body by default. Note that this has security implications; see Section 15. If the recipient of these messages (typically a SIP User Agent Client/User Agent Server - UAC/UAS) does not understand them, a negotiation using the SIP 'Accept' and 'Require' headers will take place and they will not be included in the next SIP message exchange.

There can be a Signaling Gateway (SG) between the PSTN and the MGC. It encapsulates the ISUP messages over IP in a manner such as the one described in [19]. The mapping described in this document is not affected by the underlying transport protocol of ISUP.

From "RFC3398"
(C) The Internet
Society



Note that overlap dialing mechanisms (use of the Subsequent Address Message - SAM) are outside the scope of this document. This document assumes that gateways facing ISUP networks in which overlap dialing is used will implement timers to insure that all digits have been collected before an INVITE is transmitted to a SIP network.

From "RFC3398"
(C) The Internet
Society

▲
Overlap dialing 手順はサポートされておらず、後続アドレスメッセージ (SAM) も利用される
ことはない。

In some instances, gateways may receive incomplete ISUP messages which indicate message segmentation due to excessive message length. Commonly these messages will be followed by a Segmentation Message (SGM) containing the remainder of the original ISUP message. An incomplete message may not contain sufficient parameters to allow for a proper mapping to SIP; similarly, encapsulating (see below) an incomplete ISUP message may be confusing to terminating gateways. Consequently, a gateway **MUST** wait until a complete ISUP message is received (which may involve waiting until one or more SGMs arrive) before sending any corresponding INVITE.

5. SIP Mechanisms Required

For a correct mapping between ISUP and SIP, some SIP mechanisms above and beyond those available in the base SIP specification are needed. These mechanisms are discussed below. If the SIP UAC/UAS involved in the call does not support them, it is still possible to proceed, but the behavior in the establishment of the call may be slightly different than that expected by the user (e.g., other party answers before receiving the ringback tone, user is not informed about the call being forwarded, etc.).

5.1 'Transparent' Transit of ISUP Messages

From "RFC3398"
(C) The Internet
Society

To allow gateways to take advantage of the full range of services afforded by the existing telephone network when placing calls from PSTN to PSTN across a SIP network, SIP messages **MUST** be capable of transporting ISUP payloads from gateway to gateway. The format for encapsulating these ISUP messages is defined in [3].

SIP user agents which do not understand ISUP are permitted to ignore these optional MIME bodies.

From "RFC3398"
(C) The Internet
Society

▲
本標準においては、“SIP Bridging”については範囲外としており、ISUP MIME ボディの転送に関しても検討の範囲外である。

5.2 Understanding MIME Multipart Bodies

In most PSTN interworking situations, SIP message bodies will be required to carry session information (Session Description Protocol - SDP) in addition to ISUP and/or billing information.

PSTN interworking nodes **MUST** understand the MIME type of "multipart/mixed" as defined in RFC2046 [4]. Clients express support for this by including "multipart/mixed" in an "Accept" header.

From "RFC3398"
(C) The Internet
Society

5.3 Transmission of Dual-Tone Multifrequency (DTMF) Information

How DTMF tones played by the user are transmitted by a gateway is completely orthogonal to how SIP and ISUP are interworked; however, as DTMF carriage is a component of a complete gatewaying solution some guidance is offered here.

Since the codec selected for voice transmission may not be ideally suited for carrying DTMF information, a symbolic method of transmitting this information in-band is desirable (since out-of-band transmission alone would provide many challenges for synchronization of the media stream for tone re-insertion). This transmission **MAY** be performed as described in RFC2833 [5].

5.4 Reliable Transmission of Provisional Responses

Provisional responses (in the 1xx class) are used in the transmission of call progress information. PSTN interworking in particular relies on these messages for control of the media channel and timing of call events.

When interworking with the PSTN, SIP messages **MUST** be sent reliably end-to-end; reliability of requests is guaranteed by the base protocol. One application-layer provisional reliability mechanism for responses is described in [18].

5.5 Early Media

Early media denotes the capability to play media (audio for telephony) before a SIP session has been established (before a 2xx response code has been sent). For telephony, establishment of media in the backwards direction is desirable so that tones and announcements can be played, especially when interworking with a network that cannot signal call status out of band (such as a legacy MF network). In cases where interworking has not been encountered, use of early media is almost always undesirable since it consumes inter-machine trunk resources to play media for which no revenue is collected. Note that since an INVITE almost always contains the SDP required to send media in the backwards direction, and requires that user agents prepare themselves to receive backwards media as soon as an INVITE transmitted, the baseline SIP protocol has enough support to enable rudimentary unidirectional early media systems. However, this mechanism has a number of limitations – for example, media streams offered in the SDP of the INVITE cannot be modified or declined, and bidirectional RTCP required for session maintenance cannot be established.

From "RFC3398"
(C) The Internet
Society

From "RFC3398"
(C) The Internet
Society

Therefore gateways MAY support more sophisticated early media systems as they come to be better understood. One mechanism that provides a way of initiating a fully-featured early media system is described in [20].

Note that in SIP networks not just switches but also user agents can generate the 18x response codes and initiate early backwards media, and that therefore some gateways may wish to enforce policies that restrict the use of backwards media from arbitrary user agents (see Section 15).

From "RFC3398"
(C) The Internet
Society



本仕様の範囲においては、MGC/MG を管理する事業者 SIP 網と同一もしくは応答前音源接続の合意のある事業者 SIP 網内にあって、第三者であるユーザ等が音源を操作できないことが保証されるノードからのメディアであることが判断可能である場合を除いて、2xx レスポンス受信前に逆方向パスを接続してはいけない。

5.6 Mid-Call Transactions which do not change SIP state

When interworking with the PSTN, there are situations when gateways will need to send messages to each other over SIP that do not correspond to any SIP operations.

In support of mid-call transactions and other ISUP events that do not correspond to existing SIP methods, SIP gateways MUST support the INFO method, defined in RFC2976 [6]. Note that this document does not prescribe or endorse the use of INFO to carry DTMF digits.

Gateways MUST accept "405 Method Not Allowed" and "501 Not Implemented" as non-fatal responses to INFO requests - that is, any call in progress MUST NOT be torn down if a destination so rejects an INFO request sent by a gateway.

5.7 Privacy Protection

From "RFC3398"
(C) The Internet
Society



ISUP has a concept of presentation restriction - a mechanism by which a user can specify that they would not like their telephone number to be displayed to the person they are calling (presumably someone with Caller ID). When a gateway receives an ISUP request that requires presentation restriction, it must therefore shield the identity of the caller in some fashion.

The base SIP protocol supports a method of specifying that a user is anonymous. However, this system has a number of limitations - for example, it reveals the identity of the gateway itself, which could be a privacy-impacting disclosure. Therefore gateways MAY support more sophisticated privacy systems. One mechanism that provides a way of supporting fully-featured privacy negotiation (which interacts well with identity management systems) is described in [9B].

From "RFC3398"
(C) The Internet
Society



発番号表示関連サービスをPSTNと事業者SIP網との間で提供するための、TTC ISUP上の関連要素(発番号パラメータと汎用番号パラメータ)とSIP上の要素(P-Asserted-IdentityヘッダおよびPrivacyヘッダ)との完全なマッピングについては、JJ-90.22[10]で記述される動作に従うこと。

5.8 CANCEL causes

There is a way in ISUP to signal that you would like to discontinue an attempt to set up a call – the general-purpose REL is sent in the forwards direction. There is a similar concept in SIP – that of a CANCEL request that is sent in order to discontinue the establishment of a SIP dialog. For various reasons, however, CANCEL requests cannot contain message bodies, and therefore in order to carry the important information in the REL (the cause code) end-to-end in sip bridging cases, ISUP encapsulation cannot be used.

Ordinarily, this is not a big problem, because for practical purposes the only reason that a REL is ever issued to cancel a call setup attempt is that a user hangs up the phone while it is still ringing (which results in a "Normal clearing" cause code). However, under exceptional conditions, like catastrophic network failure, a REL may be sent with a different cause code, and it would be handy if a SIP network could carry the cause code end-to-end. Therefore gateways MAY support a mechanism for end-to-end delivery of such failure reasons. One mechanism that provides this capability is described in [9].

6. Mapping

The mapping between ISUP and SIP is described using call flow diagrams and state machines. One state machine handles calls from SIP to ISUP and the second from ISUP to SIP. There are details, such as some retransmissions and some states (waiting for the Release Complete Message – RLC, waiting for SIP ACK etc.), that are not shown in the figures in order to make them easier to follow.

The boxes represent the different states of the gateway, and the arrows show changes in the state. The event that triggers the change in the state and the actions to take appear on the arrow: event / section describing the actions to take.

For example, 'INVITE / 7.2.1' indicates that an INVITE request has been received by the gateway, and the procedure upon reception is described in the section 7.2.1 of this document.

It is RECOMMENDED that gateways implement functional equivalence with the call flows detailed in Section 7.1 and Section 8.1. Deviations from these flows are permissible in support of national ISUP variants, or any of the conservative policies recommended in Section 15.

7. SIP to ISUP Mapping

7.1 SIP to ISUP Call flows

The following call flows illustrate the order of messages in typical success and error cases when setting up a call initiated from the SIP network. "100 Trying" acknowledgements to INVITE requests are not displayed below although they are required in many architectures.

In these diagrams, all call signaling (SIP, ISUP) is going to and from the MGC; media handling (e.g., audio cut-through, trunk freeing) is being performed by the MG, under the control of the MGC. For the purpose of simplicity, these are shown as a single node, labeled "MGC/MG."

7.1.1 En-bloc Call Setup (no auto-answer)

From "RFC3398"
(C) The Internet
Society

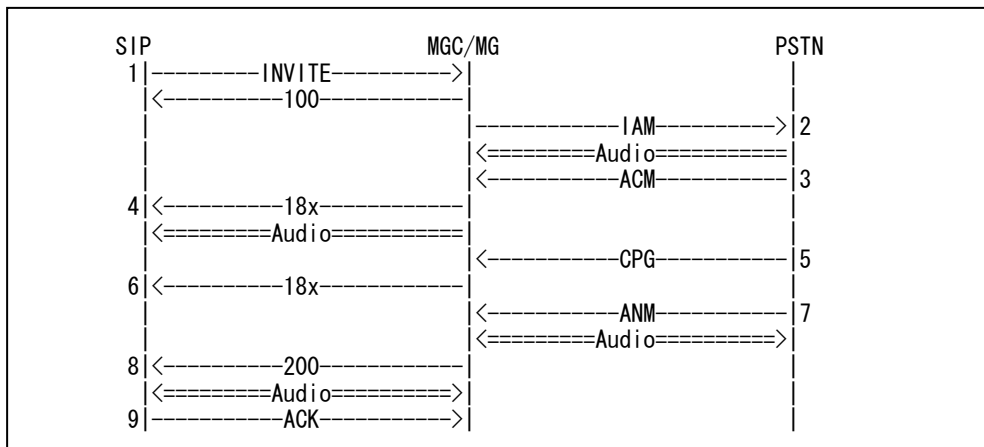

From "RFC3398"
(C) The Internet
Society



アドレスメッセージ(IAM)送信後((2)以降)、アドレス完了メッセージ(ACM)受信前((3)以前)にインチャネル情報利用可能を示す呼経過メッセージ(CPG)を受信する可能性がある。この状態において双方向パスが接続されない場合、ユーザからの入力が必要とする一部の付加サービスが利用不可となることに留意すべきであり、当該一部付加サービスの利用を可能とするためには、MGC/MGは双方向のパス接続を行い、適切なSDPを含んだ183レスポンスを送信するべきである。

また、応答メッセージ(ANM)受信前((7)以前)または応答メッセージ(ANM)受信後((7)以降)に課金メッセージ(CHG)を受信する可能性がある。その場合、応答メッセージ(ANM)受信前においては183レスポンス内にマッピングを行い、その情報を転送する。応答メッセージ(ANM)受信後においてはINFOリクエスト内にマッピングを行い、その情報を転送する。なお、課金メッセージ(CHG)で示される内容がSIP網側で必要ないとMGCが判断できる場合、MGCにおいて課金メッセージ(CHG)を廃棄してもよい。

1. When a SIP user wishes to begin a session with a PSTN user, the SIP node issues an INVITE request.
2. Upon receipt of an INVITE request, the gateway maps it to an IAM message and sends it to the ISUP network.
3. The remote ISUP node indicates that the address is sufficient to set up a call by sending back an ACM message.
4. The "called party status" code in the ACM message is mapped to a SIP provisional response (as described in Section 7.2.5 and Section 7.2.6) and returned to the SIP node. This response may contain SDP to establish an early media stream (as shown in the diagram).

From "RFC3398"
(C) The Internet
Society



If no SDP is present, the audio will be established in both directions after step 8.

Camarillo, et. al.

Standards Track

[Page 11]

From "RFC3398"
(C) The Internet
Society



パス接続に関しては各事業者マターである。ただし、前述の通りアドレス完了メッセージ (ACM) 受信前の呼経過メッセージ (CPG) 受信によるパスの接続を行う場合もあるため、留意が必要である。

5. If the ISUP variant permits, the remote ISUP node may issue a variety of Call Progress (CPG) messages to indicate, for example, that the call is being forwarded.
6. Upon receipt of a CPG message, the gateway will map the event code to a SIP provisional response (see Section 7.2.9) and send it to the SIP node.
7. Once the PSTN user answers, an Answer (ANM) message will be sent to the gateway.
8. Upon receipt of the ANM, the gateway will send a 200 message to the SIP node.
9. The SIP node, upon receiving an INVITE final response (200), will send an ACK to acknowledge receipt.

7.1.2 Auto-answer call setup

From "RFC3398"
(C) The Internet Society

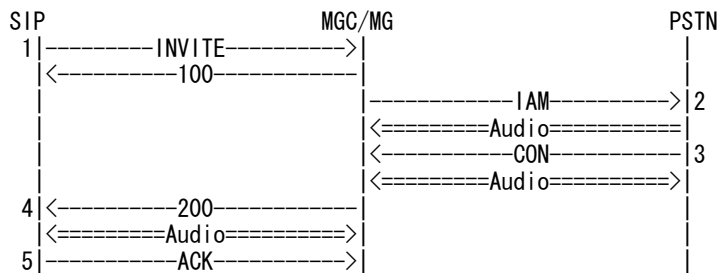

Note that this flow is not supported in ANSI networks.

From "RFC3398"
(C) The Internet Society

(JJ-90.10 注) MGCが接続メッセージ(CON)を受信することはないため、本節で規定される呼接続シーケンスを考慮する必要はない。また、MGCがアドレス完了メッセージ(ACM)を受信することなしに応答メッセージ(ANM)を受信することもない。

1. When a SIP user wishes to begin a session with a PSTN user, the SIP node issues an INVITE request.
2. Upon receipt of an INVITE request, the gateway maps it to an IAM message and sends it to the ISUP network.
3. Since the remote node is configured for automatic answering, it will send a Connect Message (CON) upon receipt of the IAM. (For ANSI, this message will be an ANM).
4. Upon receipt of the CON, the gateway will send a 200 message to the SIP node.
5. The SIP node, upon receiving an INVITE final response (200), will send an ACK to acknowledge receipt.

From "RFC3398"
(C) The Internet Society

7.1.3 ISUP T7 Expires

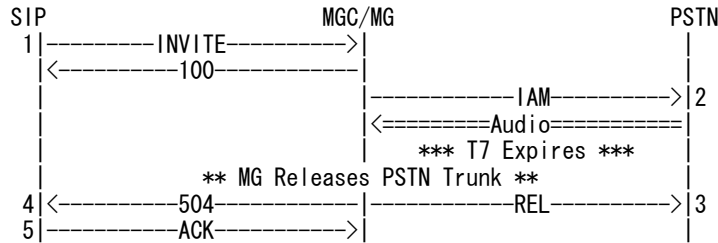

1. When a SIP user wishes to begin a session with a PSTN user, the SIP node issues an INVITE request.
2. Upon receipt of an INVITE request, the gateway maps it to an IAM message and sends it to the ISUP network. The ISUP timer T7 is started at this point.
3. The ISUP timer T7 expires before receipt of

From "RFC3398"
(C) The Internet
Society



an ACM or CON

From "RFC3398"
(C) The Internet
Society



message, so a REL message is sent to cancel the call.

From "RFC3398"
(C) The Internet
Society

T7 タイマの終了契機はアドレス完了メッセージ (ACM)、接続メッセージ (CON) および呼経過メッセージ (CPG) である。

4. A gateway timeout message is sent back to the SIP node.
5. The SIP node, upon receiving an INVITE final response (504), will send an ACK to acknowledge receipt.

7.1.4 SIP Timeout

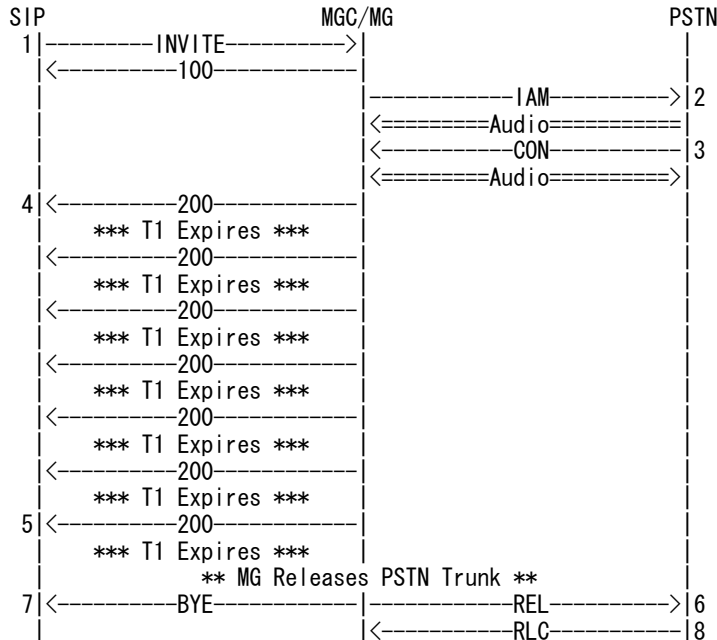

1. When a SIP user wishes to begin a session with a PSTN user, the SIP node issues an INVITE request.
2. Upon receipt of an INVITE request, the gateway maps it to an IAM message and sends it to the ISUP network.
- 3.

From "RFC3398"
(C) The Internet
Society

Since the remote node is configured for automatic answering, it will send a CON message upon receipt of the IAM.

From "RFC3398"
(C) The Internet
Society

(JJ-90.10 注) 接続メッセージ(CON)を受信することはない。

In ANSI flows,
rather than a CON, an ANM (without ACM) would be sent.

From "RFC3398"
(C) The Internet
Society

ANSIのように、アドレス完了メッセージ(ACM)を受信せずに応答メッセージ(ANM)を受信することはなく、常にアドレス完了メッセージ(ACM)受信後に応答メッセージ(ANM)を受信する。

4. Upon receipt of the ANM, the gateway will send a 200 message to the SIP node and set SIP timer T1.
5. The response is retransmitted every time the SIP timer T1 expires.
6. After seven retransmissions, the call is torn down by sending a REL to the ISUP node, with a cause code of 102 (recover on timer expiry).

Gamarillo, et. al.

Standards Track

[Page 14]

From "RFC3398"
(C) The Internet
Society

7. A BYE is transmitted to the SIP node in an attempt to close the call. Further handling for this clean up is not shown, since the SIP node's state is not easily known in this scenario.
8. Upon receipt of the REL message, the remote ISUP node will reply with an RLC message.

7.1.5 ISUP Setup Failure

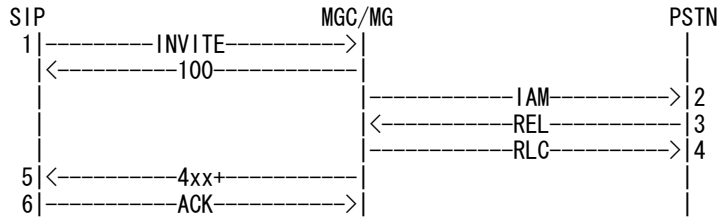

1. When a SIP user wishes to begin a session with a PSTN user, the SIP node issues an INVITE request.
2. Upon receipt of an INVITE request, the gateway maps it to an IAM message and sends it to the ISUP network.
3. Since the remote ISUP node is unable to complete the call, it will send a REL.
4. The gateway releases the circuit and confirms that it is available for reuse by sending an RLC.
5. The gateway translates the cause code in the REL to a SIP error response (see Section 7.2.4) and sends it to the SIP node.
6. The SIP node sends an ACK to acknowledge receipt of the INVITE final response.

7.1.6 Cause Present in ACM Message

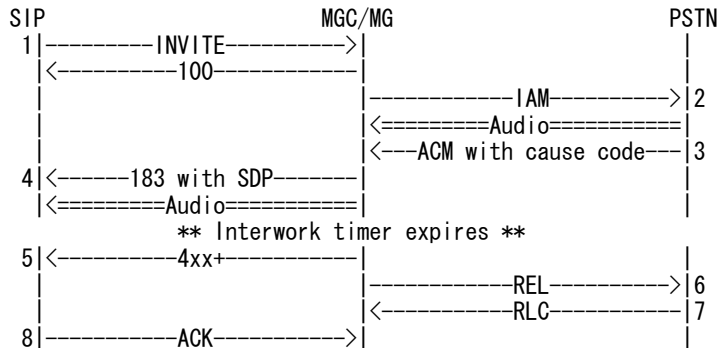

1. When a SIP user wishes to begin a session with a PSTN user, the SIP node issues an INVITE request.
2. Upon receipt of an INVITE request, the gateway maps it to an IAM message and sends it to the ISUP network.
3. Since the ISUP node is unable to complete the call and wants to generate the error tone/announcement itself, it sends an ACM with a cause code. The gateway starts an interwork timer.
4. Upon receipt of an ACM with cause (presence of the CAI parameter), the gateway will generate a 183 message towards the SIP node; this contains SDP to establish early media cut-through.

From "RFC3398"
(C) The Internet Society

5. A final INVITE response, based on the cause code received in the earlier ACM message, is generated and sent to the SIP node to terminate the call. See Section 7.2.4.1 for the table which contains the mapping from cause code to SIP response.

From "RFC3398"
(C) The Internet Society

▲
不完了を示すアドレス完了メッセージ(ACM)を送出する交換機が必要なタイマを保持する場
合が一般的である。リソース保護のために MGC/MG が上記呼切断動作を行うためのタイマを
保持する場合には、アドレス完了メッセージ(ACM)を送出する交換機等が接続する必要なアナウ
ンスメント等を途中で切断することを避けるため、十分な長さのタイマを準備しなくてはな
らない。

6. Upon expiration of the interwork timer, a REL is sent towards the PSTN node to terminate the call. Note that the SIP node can also terminate the call by sending a CANCEL before the interwork timer expires. In this case, the signaling progresses as in Section 7.1.7.
7. Upon receipt of the REL message, the remote ISUP node will reply with an RLC message.
8. The SIP node sends an ACK to acknowledge receipt of the INVITE final response.

7.1.7 Call Canceled by SIP

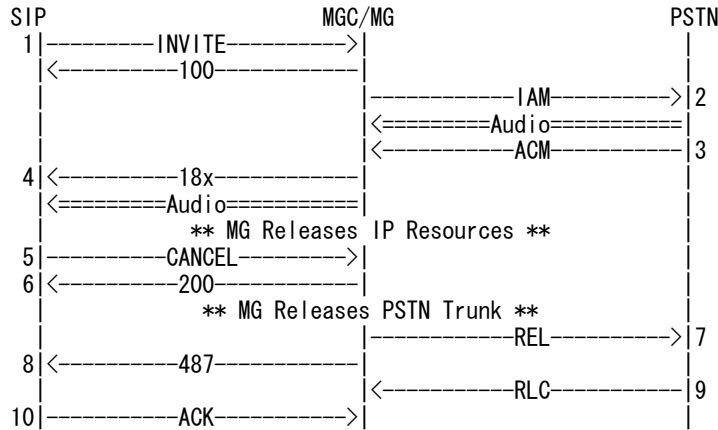

1. When a SIP user wishes to begin a session with a PSTN user, the SIP node issues an INVITE request.
2. Upon receipt of an INVITE request, the gateway maps it to an IAM message and sends it to the ISUP network.
3. The remote ISUP node indicates that the address is sufficient to set up a call by sending back an ACM message.
4. The "called party status" code in the ACM message is mapped to a SIP provisional response (as described in Section 7.2.5 and Section 7.2.6) and returned to the SIP node. This response may contain SDP to establish an early media stream.
5. To cancel the call before it is answered, the SIP node sends a CANCEL request.
6. The CANCEL request is confirmed with a 200 response.
7. Upon receipt of the CANCEL request, the gateway sends a REL message to terminate the ISUP call.
8. The gateway sends a "487 Call Cancelled" message to the SIP node to complete the INVITE transaction.
9. Upon receipt of the REL message, the remote ISUP node will reply with an RLC message.

10. Upon receipt of the 487, the SIP node will confirm reception with an ACK.

7.2 State Machine

Note that REL can be received in any state; the handling is the same for each case (see Section 10).

From "RFC3398"
(C) The Internet Society

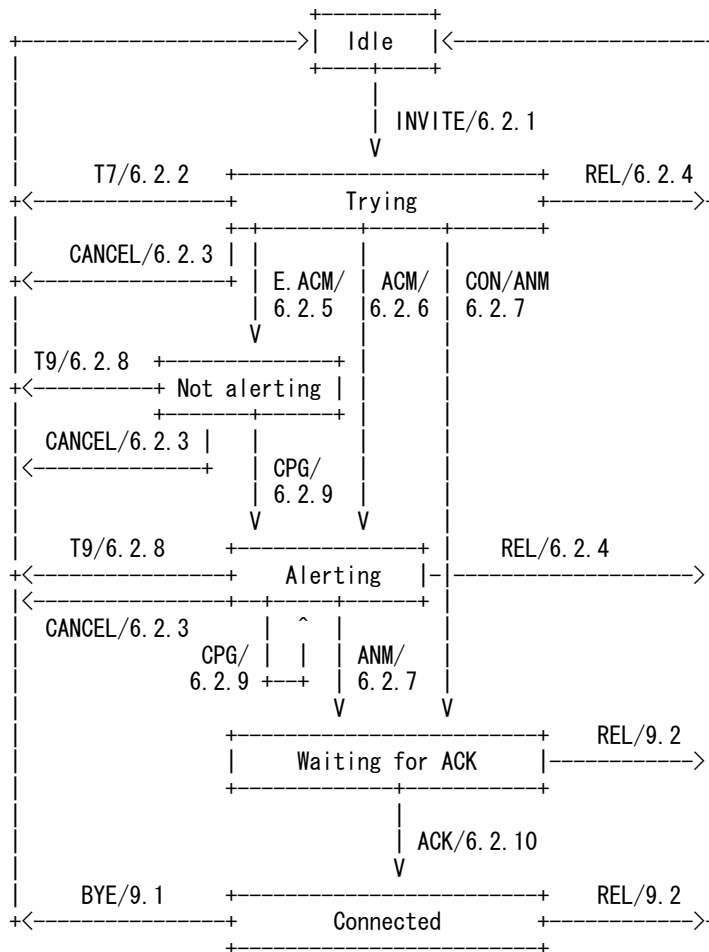

▲
上記の状態遷移図においては、“Trying”状態において呼経過メッセージ(CPG)を受信する可能性があり、その場合、T7 タイマを停止する必要があることに留意すべきである。

上記の Idle 以外の状態において、課金メッセージ(CHG)を受信する可能性があるが、その場合には別の状態への遷移が行われることはない。

7.2.1 INVITE received

When an INVITE request is received by the gateway, a "100 Trying" response MAY be sent back to the SIP network indicating that the gateway is handling the call.

The necessary hardware resources for the media stream MUST be reserved in the gateway when the INVITE is received, since an IAM message cannot be sent before the resource reservation (especially TCIC selection) takes place. Typically the resources consist of a time slot in an E1/T1 and an RTP/UDP port on the IP side. Resources might also include any quality-of-service provisions (although no such practices are recommended in this document).

After sending the IAM the timer T7 is started. The default value of T7 is between 20 and 30 seconds. The gateway goes to the 'Trying' state.

7.2.1.1 INVITE to IAM procedures

This section details the mapping of the SIP headers in an INVITE message to the ISUP parameters in an Initial Address Message (IAM). A PSTN-SIP gateway is responsible for creating an IAM when it receives an INVITE.

Five mandatory parameters appear within the IAM message: the Called Party Number (CPN), the Nature of Connection Indicator (NCI), the Forward Call Indicators (FCI), the Calling Party's Category (CPC), and finally a parameter that indicates the desired bearer characteristics of the call –

From "RFC3398"
(C) The Internet Society

in some ISUP variants the Transmission Medium Requirement (TMR) is required, in others the User Service Information (USI) (or both).

From "RFC3398"
(C) The Internet Society

▲
TMR は必須パラメータであり、USI は必須パラメータではない。

All IAM messages MUST contain these five parameters at a minimum. Thus, every gateway must have a means of populating each of those five parameters when an INVITE is received. Many of the values that will appear in these parameters (such as the NCI or USI) will most likely be the same for each IAM created by the gateway. Others (such as the CPN) will vary on a call-by-call basis; the gateway extracts information from the INVITE in order to properly populate these parameters.

From "RFC3398"
(C) The Internet Society

There are also quite a few optional parameters that can appear in an IAM message: Q.763 [17] lists 29 in all. However, each of these parameters need not to be translated in order to achieve the goals of SIP-ISUP mapping. As is stated above, translation allows SIP network elements to understand the basic PSTN context of the session (who it is for, and so on) if they are not capable of deciphering any encapsulated ISUP. Parameters that are only meaningful to the PSTN will be carried through PSTN-SIP- PSTN networks via encapsulation -

translation is not necessary for these parameters. Of the aforementioned 29 optional parameters, only the following are immediately useful for translation: the Calling Party's Number (CIN, which is commonly present), Transit Network Selection (TNS), Carrier Identification Parameter (CIP, present in ANSI networks), Original Called Number (OCN), and

From "RFC3398"
(C) The Internet Society

the Generic Digits (known in some variants as the Generic Address Parameter (GAP)).

From "RFC3398"
(C) The Internet Society

(JJ-90.10 注) 汎用ディジット (Generic Digits) は使用されない。

When a SIP INVITE arrives at a PSTN gateway, the gateway SHOULD attempt to make use of encapsulated ISUP (see [3]), if any, within the INVITE to assist in the formulation of outbound PSTN signaling, but SHOULD also heed the security considerations in Section 15. If possible, the gateway SHOULD reuse the values of each of the ISUP parameters of the encapsulated IAM as it formulates an IAM that it will send across its PSTN interface. In some cases, the gateway will be unable to make use of that ISUP – for example, if the gateway cannot understand the ISUP variant and must therefore ignore the encapsulated body. Even when there is comprehensible encapsulated ISUP, the relevant values of SIP header fields MUST 'overwrite' through the process of translation the parameter values that would have been set based on encapsulated ISUP. In other words, the updates to the critical session context parameters that are created in the SIP network take precedence, in ISUP-SIP-ISUP bridging cases, over the encapsulated ISUP. This allows many basic services, including various sorts of call forwarding and redirection, to be implemented in the SIP network.

For example, if an INVITE arrives at a gateway with an encapsulated IAM with a CPN field indicating the telephone number +12025332699, but the Request-URI of the INVITE indicates 'tel:+15105550110', the gateway MUST use the telephone number in the Request-URI, rather than the one in the encapsulated IAM, when creating the IAM that the gateway will send to the PSTN. Further details of how SIP header fields are translated into ISUP parameters follow.

Gateways MUST be provisioned with default values for mandatory ISUP parameters that cannot be derived from translation (such as the NCI or TMR parameters) for those cases in which no encapsulated ISUP is present. The FCI parameter MUST also have a default,

From "RFC3398"
(C) The Internet Society

as only the 'M' bit of the default may be overwritten during the process of translation if the optional number portability translation mechanisms described below are used.

From "RFC3398"
(C) The Internet Society

'M' bit は設定されず意味を持たない。また、'M' bit の内容は ITU-T Q.763 にも規定されて

おらず、ANSI 等の地域特有 ISUP における規定である。

The first step in the translation of the fields of an INVITE message to the parameters of an IAM is the inspection of the Request-URI.

Gamarillo, et. al.

Standards Track

[Page 20]

From "RFC3398"
(C) The Internet
Society



If the optional number portability practices are supported by the gateway, then the following steps related to handling of the 'npdi' and 'rn' parameters of the Request-URI should be followed.

If there is no 'npdi=yes' field within the Request-URI, then the primary telephone number in the tel URL (the digits immediately following 'tel:') MUST be converted to ISUP format, following the procedures described in Section 12, and used to populate the CPN parameter.

If the 'npdi=yes' field exists in the Request-URI, then the FCI parameter bit for 'number translated' within the IAM MUST reflect that a number portability dip has been performed.

If in addition to the 'npdi=yes' field there is no 'rn=' field present, then the main telephone number in the tel URL MUST be converted to ISUP format (see Section 12) and used to populate the CPN parameter. This indicates that a portability dip took place, but that the called party's number was not ported.

If in addition to the 'npdi=yes' field an 'rn=' field is present, then in ANSI ISUP the 'rn=' field MUST be converted to ISUP format and used to populate the CPN. The main telephone number in the tel URL MUST be converted to ISUP format and used to populate the Generic Digits Parameter (or GAP in ANSI). In some other ISUP variants, the number given in the 'rn=' field would instead be prepended to the main telephone number (with or without a prefix or separator) and the combined result MUST be used to populate the CPN. Once the 'rn=' and 'npdi=' parameters have been translated, the number portability translation practices are complete.

The following mandatory translation practices are performed after number portability translations, if any.

If number portability practices are not supported by the gateway, then the primary telephone number in the tel URL (the digits immediately following 'tel:') MUST be converted to ISUP format, following the procedures described in Section 12, and used to populate the CPN parameter.

If the primary telephone number in the Request-URI and that of the To header are at variance, then the To header SHOULD be used to populate an OCN parameter. Otherwise the To header SHOULD be ignored.

Some optional translation procedures are provided for carrier-based routing. If the 'cic=' parameter is present in the Request-URI, the gateway SHOULD consult local policy to make sure that it is appropriate to transmit this Carrier Identification Code (CIC, not to

be confused with the MTP3 'circuit identification code') in the IAM: if the gateway supports many independent trunks, it may need to choose a particular trunk that points to the carrier identified by the CIC, or a tandem through which that carrier is reachable. Policies for such trunks (based on the preferences of the carriers with which the trunks are associated and the ISUP variant in use) SHOULD dictate whether the CIP or TNS parameter is used to carry the CIC. In the absence of any pre-arranged policies, the TNS should be used when the CPN parameter is in an international format (i.e., the tel URL portion of the Request-URI is preceded by a '+', which will generate a CPN in international format), and (where supported) the CIP should be used in other cases.

From "RFC3398"
(C) The Internet
Society



上記の npdi=、rn=、cic=の各パラメタの使用法および ISUP へのマッピング規定等については ANSI 特有の動作を規定しており、TTCにおいて相当する動作については本標準では規定しない。また、番号ポータビリティに関する動作は本標準の範囲外であり規定しない。

When a SIP call has been routed to a gateway, then the Request-URI will most likely contain a tel URL (or a SIP URI with a tel URL user portion) - SIP-ISUP gateways that receive Request-URIs that do not contain valid telephone numbers SHOULD reject such requests with an appropriate response code. Gateways SHOULD however continue to process requests with a From header field that does not contain a telephone number, as will sometimes be the case if a call originated at a SIP phone that employs a SIP URI user@host convention.

From "RFC3398"
(C) The Internet
Society



The CIN parameter SHOULD be omitted from the outbound IAM if the From field is unusable.

From "RFC3398"
(C) The Internet
Society



Note that as an alternative, gateway implementers MAY consider some non-standard way of mapping particular SIP URIs to telephone numbers.

From "RFC3398"
(C) The Internet
Society

(JJ-90.10 注) 国際からの着信等で発番号パラメータがアドレスメッセージ(IAM)に設定されない可能性があるが、SIP からのインタワークにおいてこれを許容するかについては本標準の内容の範囲外であり、別途整理される必要がある。



When a gateway receives a message with (comprehensible) encapsulated ISUP, it MUST set the FCI indicator in the generated IAM so that all interworking-related bits have the same values as their counterparts in the encapsulated ISUP. In most cases, these indicators will state that no interworking was encountered, unless interworking has been encountered somewhere else in the call path. If usable encapsulated ISUP is not present in an INVITE received by the gateway, it is STRONGLY RECOMMENDED that the gateway set the Interworking Indicator bit of the FCI to 'no interworking' and the ISDN User Part Indicator to 'ISUP used all the way'; the gateway MAY also set the Originating Access indicator to 'Originating access non-ISDN' (generally, it is not safe to assume that SIP phones will support ISDN endpoint services, and the procedures in this document do not detail mappings

From "RFC3398"
(C) The Internet
Society

to translate all such services).

Note that when 'interworking encountered' is set in the FCI parameter of the IAM, this indicates that ISUP is interworking with a network which is not capable of providing as many services as ISUP does. ISUP networks will therefore not employ certain features they otherwise normally would, including potentially the use of ISDN cause codes in failure conditions (as opposed to sending ACMs followed by audible announcements). If desired, gateway vendors MAY provide a

configurable option, usable at the discretion of service providers, that will signal in the FCI that interworking has been encountered (and that ISUP is not used all the way) when encapsulated ISUP is not present; however, doing so may significantly limit the efficiency and transparency of SIP-ISUP translation.

From "RFC3398"
(C) The Internet Society



アドレスメッセージ(IAM)に設定されるパラメータのISDNアクセス表示の設定値は、事業者SIP網が自己の管理するユーザへ提供するサービスレベルに基づき決定されるものである。その他のパラメータに関しては、ISDNアクセス表示の設定により設定基準が異なる。“発側のユーザ・網インタフェースが非ISDN”を適用する場合のアドレスメッセージ(IAM)に設定される主要パラメータのデフォルト設定値を付属資料 aのa.1節に、留意点を付属資料 bに示す。また、“発側のユーザ・網インタフェースがISDN”を適用する場合は、JT-Q699[8]に従うこととし、JT-Q699[8]未規定部分は付属資料 aのa.1節の記載に従う。

Claiming to be an ISDN node might make the callee request ISDN user to user services.

From "RFC3398"
(C) The Internet Society



Since user to user services 1 and 2 must be requested by the caller, they do not represent a problem (see [14]). User to user service 3 can be requested by the callee also.

From "RFC3398"
(C) The Internet Society



In non-SIP bridging situations, the MGC should be capable of rejecting this service request.

From "RFC3398"
(C) The Internet Society

JT-Q730においてユーザ・ユーザ情報転送(UUS)サービス1のみを規定しているため、ユーザ・ユーザ情報転送(UUS)サービス2、ユーザ・ユーザ情報転送(UUS)サービス3についてユーザから要求されることはない。

7.2.2 ISUP T7 expires

From "RFC3398"
(C) The Internet Society



Since no response was received from the PSTN all the resources in the MG are released. A '504 Server Timeout' SHOULD be sent back to the SIP network. A REL message with cause value 102 (protocol error, recovery on timer expiry) SHOULD be sent to the PSTN. Gateways can expect the PSTN to respond with RLC and the SIP network to respond with an ACK indicating that the release sequence has been completed.

From "RFC3398"
(C) The Internet Society



T7 タイマ満了時に送出する切断メッセージ(REL)の理由表示値の設定については、特定の値(#102)の設定を規定せず、各事業者の実装動作によるものとする。

7.2.3 CANCEL or BYE received

If a CANCEL or BYE request is received before a final SIP response has been sent, a '200 OK' MUST be sent to the SIP network to confirm the CANCEL or BYE; a 487 MUST also be sent to terminate the INVITE transaction. All the resources are released and a REL message SHOULD be sent to the PSTN with cause value 16 (normal clearing). Gateways

From "RFC3398"
(C) The Internet Society

can expect an RLC from the PSTN to be received indicating that the release sequence is complete.

In SIP bridging situations, a REL might be encapsulated in the body of a BYE request. Although BYE is usually mapped to cause code 16 (normal clearing), under exceptional circumstances the cause code in the REL message might be different. Therefore the Cause Indicator parameter of the encapsulated REL should be re-used in the REL sent to the PSTN.

Note that a BYE or CANCEL request may contain a Reason header that SHOULD be mapped to the Cause Indicator parameter (see Section 5.8). If a BYE contains both a Reason header and encapsulated ISUP, the value in the Reason header MUST be preferred.

All the resources in the gateway SHOULD be released before the gateway sends any REL message.

7.2.4 REL received

This section applies when a REL is received before a final SIP response has been sent. Typically, this condition arises when a call has been rejected by the PSTN.

Any gateway resources SHOULD be released immediately and an RLC MUST be sent to the ISUP network to indicate that the circuit is available for reuse.

If the INVITE that originated this transaction contained a legitimate and comprehensible encapsulated ISUP message (i.e., an IAM using a variant supported by the gateway, preferably with a digital signature), then encapsulated ISUP SHOULD be sent in the response to the INVITE when possible (since this suggests an ISUP-SIP-ISUP bridging case) - therefore, the REL message just received SHOULD be included in the body of the SIP response. The gateway SHOULD NOT return a response with encapsulated ISUP if the originator of the INVITE did not enclose ISUP itself.

Note that the receipt of certain maintenance messages in response to IAM such as Blocking Message (BLO) or Reset Message (RSC) (or their circuit group message equivalents) may also result in the teardown of calls in this phase of the state machine. Behavior for maintenance messages is given below in Section 11.

7.2.4.1 ISDN Cause Code to Status Code Mapping

The use of the REL message in the SS7 network is very general, whereas SIP has a number of specific tools that, collectively, play the same role as REL - namely BYE, CANCEL, and the various status/response codes. An REL can be sent to tear down a call that is already in progress (BYE), to cancel a previously sent call setup request that has not yet been completed (CANCEL), or to reject a call setup request (IAM) that has just been received (corresponding to a SIP status code).

From "RFC3398"
(C) The Internet
Society

Note that it is not necessarily appropriate to map some ISDN cause codes to SIP messages because these cause codes are only meaningful to the ISUP interface of a gateway. A good example of this is cause code 44 "Request circuit or channel not available." 44 signifies that the CIC for which an IAM had been sent was believed by the receiving equipment to be in a state incompatible with a new call request - however, the appropriate behavior in this case is for the originating switch to re-send the IAM for a different CIC, not for the call to be torn down. Clearly, there is not (nor should there be) an SIP status code indicating that a new CIC should be selected - this matter is internal to the originating gateway. Hence receipt of cause code 44

From "RFC3398"
(C) The Internet
Society

should not result in any SIP status code being sent; effectively, the cause code is untranslatable.

If a cause value other than those listed below is received, the default response '500 Server internal error' SHOULD be used.

Finally, in addition to the ISDN Cause Code, the CAI parameter also contains a cause 'location' that gives some sense of which entity in the network was responsible for terminating the call (the most important distinction being between the user and the network). In most cases, the cause location does not affect the mapping to a SIP status code; some exceptions are noted below. A diagnostic field may also be present for some ISDN causes; this diagnostic will contain additional data pertaining to the termination of the call.

From "RFC3398"
(C) The Internet
Society

▲
ANSI 特有の動作を規定しており、TTCにおいて相当する動作については規定しない。

The following mapping values are RECOMMENDED:

Normal event

ISUP Cause value	SIP response
1 unallocated number	404 Not Found
2 no route to network	404 Not found
3 no route to destination	404 Not found
16 normal call clearing	--- (*)
17 user busy	486 Busy here
18 no user responding	408 Request Timeout
19 no answer from the user	480 Temporarily unavailable
20 subscriber absent	480 Temporarily unavailable
21 call rejected	403 Forbidden (+)
22 number changed (w/o diagnostic)	410 Gone
22 number changed (w/ diagnostic)	301 Moved Permanently
23 redirection to new destination	410 Gone
26 non-selected user clearing	404 Not Found (=)
27 destination out of order	502 Bad Gateway
28 address incomplete	484 Address incomplete
29 facility rejected	501 Not implemented
31 normal unspecified	480 Temporarily unavailable

From "RFC3398"
(C) The Internet
Society

▼

1 unallocated number	404 Not Found
----------------------	---------------

From "RFC3398"
(C) The Internet
Society

▲
ISUP側の理由表示値#1は欠番を意味するものであり、理由表示値#1の切断メッセージ(REL)のマッピングについては、SIP側で欠番を示すレスポンスにマッピングする。事業者SIP網間の接続インタフェース(インタフェースA) [12]により、Reasonヘッダ(Q. 850; cause=1) [11]を付加した404レスポンスへのマッピングが推奨される。

2 no route to network	404 Not found
3 no route to destination	404 Not found
16 normal call clearing	--- (*)
17 user busy	486 Busy here
18 no user responding	408 Request Timeout
19 no answer from the user	480 Temporarily unavailable
20 subscriber absent	480 Temporarily unavailable
21 call rejected	403 Forbidden (+)
22 number changed (w/o diagnostic)	410 Gone
22 number changed (w/ diagnostic)	301 Moved Permanently
23 redirection to new destination	410 Gone
26 non-selected user clearing	404 Not Found (=)
27 destination out of order	502 Bad Gateway
28 address incomplete	484 Address incomplete
29 facility rejected	501 Not implemented
31 normal unspecified	480 Temporarily unavailable

From "RFC3398"
(C) The Internet
Society

▼

(*) ISDN Cause 16 will usually result in a BYE or CANCEL
--

From "RFC3398"
(C) The Internet
Society

▲
理由表示値#16の切断メッセージ(REL)のマッピングについては、呼完了前は480レスポンスにマッピングする。

(+) If the cause location is 'user' than the 6xx code could be given rather than the 4xx code (i.e., 403 becomes 603)

(=) ANSI procedure - in ANSI networks, 26 is overloaded to signify 'misrouted ported number'. Presumably, a number portability dip should have been performed by a prior network. Otherwise cause 26 is usually not used in ISUP procedures.

Gamarillo, et. al.

Standards Track

[Page 25]

From "RFC3398"
(C) The Internet
Society

A REL with ISDN cause 22 (number changed) might contain information about a new number where the callee might be reachable in the diagnostic field. If the MGC is able to process this information it SHOULD be added to the SIP response (301) in a Contact header.

Resource unavailable

This kind of cause value indicates a temporary failure. A 'Retry-After' header MAY be added to the response if appropriate.

<u>ISUP Cause value</u>	<u>SIP response</u>
34 no circuit available	503 Service unavailable
38 network out of order	503 Service unavailable
41 temporary failure	503 Service unavailable
42 switching equipment congestion	503 Service unavailable
47 resource unavailable	503 Service unavailable

Service or option not available

This kind of cause value indicates that there is a problem with the request, rather than something that will resolve itself over time.

<u>ISUP Cause value</u>	<u>SIP response</u>
55 incoming calls barred within CUG	403 Forbidden
57 bearer capability not authorized	403 Forbidden
58 bearer capability not presently available	503 Service unavailable

Service or option not available

<u>ISUP Cause value</u>	<u>SIP response</u>
65 bearer capability not implemented	488 Not Acceptable Here
70 only restricted digital avail	488 Not Acceptable Here
79 service or option not implemented	501 Not implemented

Invalid message

<u>ISUP Cause value</u>	<u>SIP response</u>
87 user not member of CUG	403 Forbidden
88 incompatible destination	503 Service unavailable

Protocol error

<u>ISUP Cause value</u>	<u>SIP response</u>
102 recovery of timer expiry	504 Gateway timeout
111 protocol error	500 Server internal error

Interworking

<u>ISUP Cause value</u>	<u>SIP response</u>
127 interworking unspecified	500 Server internal error

7.2.5 Early ACM received

An ACM message is sent in certain situations to indicate that the call is in progress in order to satisfy ISUP timers, rather than to signify that the callee is being alerted. This occurs for example in mobile networks, where roaming can delay call setup significantly. The early ACM is sent before the user is alerted to reset T7 and start T9. An ACM is considered an 'early ACM' if the Called Party's Status Indicator is set to 00 (no indication).

After sending an early ACM, the ISUP network can be expected to indicate the further progress of the call by sending CPGs.

When an early ACM is received the gateway SHOULD send a 183 Session Progress response (see [1]) to the SIP network. In SIP bridging situations (where encapsulated ISUP was contained in the INVITE that initiated this call) the early ACM SHOULD also be included in the response body.

Note that sending 183 before a gateway has confirmation that the address is complete (ACM) creates known problems in SIP bridging cases, and it SHOULD NOT therefore be sent.

7.2.6 ACM received

Most commonly, on receipt of an ACM a provisional response (in the 18x class) SHOULD be sent to the SIP network. If the INVITE that initiated this session contained legitimate and comprehensible encapsulated ISUP, then the ACM received by the gateway SHOULD be encapsulated in the provisional response.

From "RFC3398"
(C) The Internet
Society



If the ACM contains a Backward Call Indicators parameter with a value of 'subscriber free', the gateway SHOULD send a '180 Ringing' response. When a 180 is sent, it is assumed, in the absence of any early media extension, that any necessary ringback tones will be

From "RFC3398"
(C) The Internet
Society

generated locally by the SIP user agent to which the gateway is responding (which may in turn be a gateway).

If the Backward Call Indicators (BCI) parameter of the ACM indicates that interworking has been encountered (generally designating that the ISUP network sending the ACM is interworking with a less sophisticated network which cannot report its status via out-of-band signaling), then there may be in-band announcements of call status such as an audible busy tone or caller intercept message, and if possible a backwards media transmission SHOULD be initiated. Backwards media SHOULD also be transmitted if the Optional Backward Call Indicators parameter field for in-band media is set. For more information on early media (before 200 OK/ANM) see Section 5.5. After early media transmission has been initiated, the gateway SHOULD send a 183 Session Progress response code.

From "RFC3398"
(C) The Internet Society

▲
パス接続に関しては各事業者マターである。

Gateways MAY have some means of ascertaining the disposition of in-band audio media; for example, a way of determining by inspecting signaling in some ISUP variants, or by listening to the audio, that ringing, or a busy tone, is being played over the circuit. Such gateways MAY elect to discard the media and send the corresponding response code (such as 180 or 486) in its stead. However, the implementation of such a gateway would entail overcoming a number of known challenges that are outside the scope of this document.

From "RFC3398"
(C) The Internet Society

▼
When they receive an ACM, switches in many ISUP networks start a timer known as "T9" which usually lasts between 90 seconds and 3 minutes (see [13]). When early media is being played, this timer permits the caller to hear backwards audio media (in the form ringback, tones or announcements) from a remote switch in the ISUP network for that period of time without incurring any charge for the connection. The nearest possible local ISUP exchange to the callee generates the ringback tone or voice announcements. If longer announcements have to be played, the network has to send an ANM, which initiates bidirectional media of indefinite duration. In common ISUP network practice, billing commences when the ANM is received. Some networks do not support timer T9.

From "RFC3398"
(C) The Internet Society

▲
T9 タイマは適用されないため、アドレス完了メッセージ(ACM)の受信に際して T9 タイマは起動しない。また、したがって一般的な T9 タイマの値を超えるアナウンスを聞かせるために別途 ANM を送信する必要はない。

7.2.7 CON or ANM Received

From "RFC3398"
(C) The Internet
Society

(JJ-90.10 注) 接続メッセージ(CON)を受信することはない。

When an ANM or CON message is received, the call has been answered and thus '200 OK' response SHOULD be sent to the SIP network. This 200 OK SHOULD contain an answer to the media offered in the INVITE. In SIP bridging situations (when the INVITE that initiated this call contained legitimate and comprehensible encapsulated ISUP), the ISUP message is included in the body of the 200 OK response.

From "RFC3398"
(C) The Internet
Society

▼

If it has not done so already, the gateway MUST establish a bidirectional media stream at this time.

From "RFC3398"
(C) The Internet
Society

Camarillo, et. al.

Standards Track

[Page 28]

▲
アドレス完了メッセージ(ACM)受信前にインチャネル情報利用可能を示す呼経過メッセージ(CPG)を受信する可能性がある。その場合、アドレス完了メッセージ(ACM)受信前にすでに双方向のパスが接続されている可能性がある。なお、パス接続に関しては各事業者マターである。

When there is interworking with some legacy networks, it is possible for an ISUP switch to receive an ANM immediately after an early ACM (without CPG or any other backwards messaging), or without receiving any ACM at all (when an automaton answers the call). In this situation the SIP user will never have received a 18x provisional response, and consequently they will not hear any kind of ringtone before the callee answers. This may result in some clipping of the initial forward media from the caller (since forward media transmission cannot commence until SDP has been acquired from the destination). In ISDN (see [12]) this is solved by connecting the voice path backwards before sending the IAM.

7.2.8 Timer T9 Expires

From "RFC3398"
(C) The Internet
Society

本仕様では、ITU-T Q.764[7]で規定される T9 と同等の規定に従う「ANM 待ちインタワークタイム」を規定する。本節の“Timer T9”および“T9”はこの「ANM 待ちインタワークタイム」と読み替える。

TTC ISUP としては T9 は規定していないが、SIP-ISUP のインタワークにおいて、インタワークタイムとして ACM 受信後の ANM 待ちタイムが必要となる。(呼設定中の発側 SIP 網(ユーザ含む)障害等で着側端末が呼出し状態のままとなり、網内リソースも保持されたままとなる可能性等があるためである)

The expiry of this timer (which is not used in all networks) signifies that an ANM has not arrived a significant period of time after alerting began (with the transmission of an ACM) for this call. Usually, this means that the callee's terminal has been alerted for many rings but has not been answered. It may also occur in interworking cases when the network is playing a status announcement (such as one indicating that a number is not in service) that has cycled several times. Whatever the cause of the protracted incomplete call, when this timer expires the call MUST be released. All of the gateway resources related to the media path SHOULD be released. A '480 Temporarily Unavailable' response code SHOULD be sent to the SIP network, and an REL message with cause value 19 (no answer from the user) SHOULD be sent to the ISUP network. The PSTN can be expected to respond with an RLC and the SIP network to respond with an ACK indicating that the release sequence has been completed.

7.2.9 CPG Received

From "RFC3398"
(C) The Internet
Society

A CPG is a provisional message that can indicate progress, alerting or in-band information. If a CPG suggests that in-band information is available, the gateway SHOULD begin to transmit early media and cut through the unidirectional backwards media path.

Camarillo, et. al.

Standards Track

[Page 29]

From "RFC3398"
(C) The Internet
Society

▲ アドレス完了メッセージ (ACM) 受信前にインチャネル情報利用可能を示す呼経過メッセージ (CPG) を受信する可能性がある。その場合、付加サービス等の利用を可能とするため、順方向のパスを接続するべきである。なお、パス接続に関しては各事業者マターである。

In SIP bridging situations (when the INVITE that initiated this session contained legitimate and comprehensible encapsulated ISUP), the CPG SHOULD be sent in the body of a particular 18x response, determined from the CPG Event Code as follows:

ISUP event code	SIP response
1 Alerting	180 Ringing
2 Progress	183 Session progress
3 In-band information	183 Session progress
4 Call forward; line busy	181 Call is being forwarded
5 Call forward; no reply	181 Call is being forwarded
6 Call forward; unconditional	181 Call is being forwarded
- (no event code present)	183 Session progress

Note that if the CPG does not indicate "Alerting," the current state will not change.

7.3 ACK received

At this stage, the call is fully connected and the conversation can take place. No ISUP message should be sent by the gateway when an ACK is received.

8. ISUP to SIP Mapping

8.1 ISUP to SIP Call Flows

The following call flows illustrate the order of messages in typical success and error cases when setting up a call initiated from the PSTN network. "100 Trying" acknowledgements to INVITE requests are not depicted, since their presence is optional.

In these diagrams, all call signaling (SIP, ISUP) is going to and from the MGC; media handling (e.g., audio cut-through, trunk freeing) is being performed by the MG, under the control of the MGC. For the purpose of simplicity, these are shown as a single node, labeled "MGC/MG".

8.1.1 En-bloc call setup (non auto-answer)

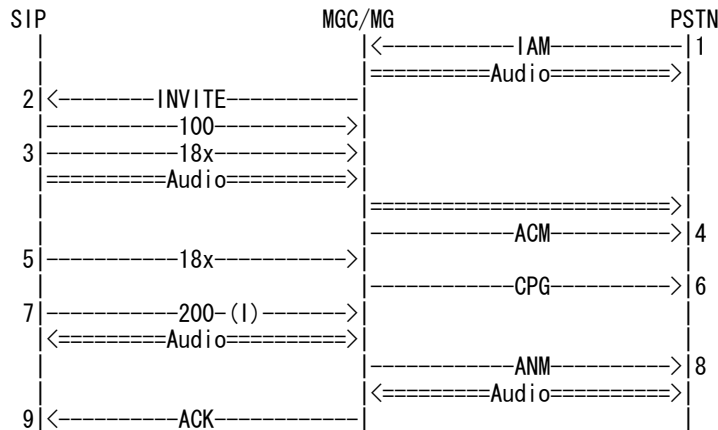

1. When a PSTN user wishes to begin a session with a SIP user, the PSTN network generates an IAM message towards the gateway.
2. Upon receipt of the IAM message, the gateway generates an INVITE message, and sends it to an appropriate SIP node.
3. When an event signifying that the call has sufficient addressing information occurs, the SIP node will generate a provisional response of 180 or greater.
4. Upon receipt of a provisional response of 180 or greater, the gateway will generate an ACM message. If the response is not 180, the ACM will carry a "called party status" value of "no indication."
5. The SIP node may use further provisional messages to indicate session progress.
6. After an ACM has been sent, all provisional responses will translate into ISUP CPG messages as indicated in Section 8.2.3.
7. When the SIP node answers the call, it will send a 200 OK message.
8. Upon receipt of the 200 OK message, the gateway will send an ANM message towards the ISUP node.
9. The gateway will send an ACK to the SIP node to acknowledge receipt of the INVITE final response.

8.1.2 Auto-answer call setup

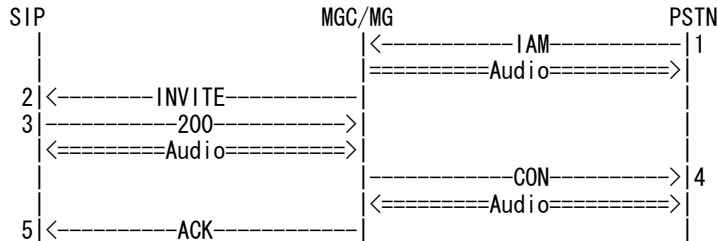

1. When a PSTN user wishes to begin a session with a SIP user, the PSTN network generates an IAM message towards the gateway.
2. Upon receipt of the IAM message, the gateway generates an INVITE message and sends it to an appropriate SIP node based on called number analysis.
3. Since the SIP node is set up to automatically answer the call, it will send a 200 OK message.

From "RFC3398"
(C) The Internet Society

4. Upon receipt of the 200 OK message, the gateway will send a CON message towards the ISUP node.

From "RFC3398"
(C) The Internet Society

▲ (JJ-90.10 注) 接続メッセージ(CON)の送出が許容されないため、アドレス完了メッセージ(ACM)および応答メッセージ(ANM)の2つのメッセージにマッピングを行う(なおその際には、後位の交換機の正常な動作を保証するために2つのメッセージの間隔を64ms以上空けて送出することが推奨される)。また、アドレス完了メッセージ(ACM)の内容は180レスポンス受信時の内容(8.2.3節)に従う。200 OK レスポンスにISUPメッセージ(CONまたはANM)がカプセルリングされている場合は、異なるISUP網の相互接続であり、本標準の内容の範囲外であるが、適切にアドレス完了メッセージ(ACM)および応答メッセージ(ANM)の2つのメッセージにマッピングされるべきである。その際のアドレス完了メッセージ(ACM)は次に送出する応答メッセージ(ANM)の内容と齟齬のない値に設定されるべきである。

5. The gateway will send an ACK to the SIP node to acknowledge receipt of the INVITE final response.

From "RFC3398"
(C) The Internet Society

8.1.3 SIP Timeout

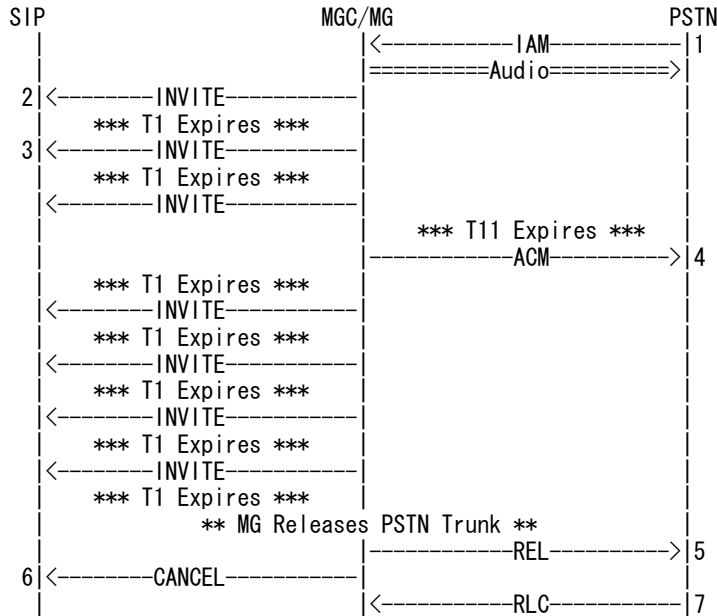

1. When a PSTN user wishes to begin a session with a SIP user, the PSTN network generates an IAM message towards the gateway.
2. Upon receipt of the IAM message, the gateway generates an INVITE message, and sends it to an appropriate SIP node based on called number analysis. The ISUP timer T11 and SIP timer T1 are set at this time.
3. The INVITE message will continue to be sent to the SIP node each time the timer T1 expires. The SIP standard specifies that INVITE transmission will be performed 7 times if no response is received.

4. When T11 expires, an ACM message will be sent to the ISUP node to prevent the call from being torn down by the remote node's ISUP T7. This ACM contains a 'Called Party Status' value of 'no indication.'
5. Once the maximum number of INVITE requests has been sent, the gateway will send a REL (cause code 18) to the ISUP node to terminate the call.
6. The gateway also sends a CANCEL message to the SIP node to terminate any initiation attempts.
7. Upon receipt of the REL, the remote ISUP node will send an RLC to acknowledge.

8.1.4 ISUP T9 Expires

From "RFC3398"
(C) The Internet
Society

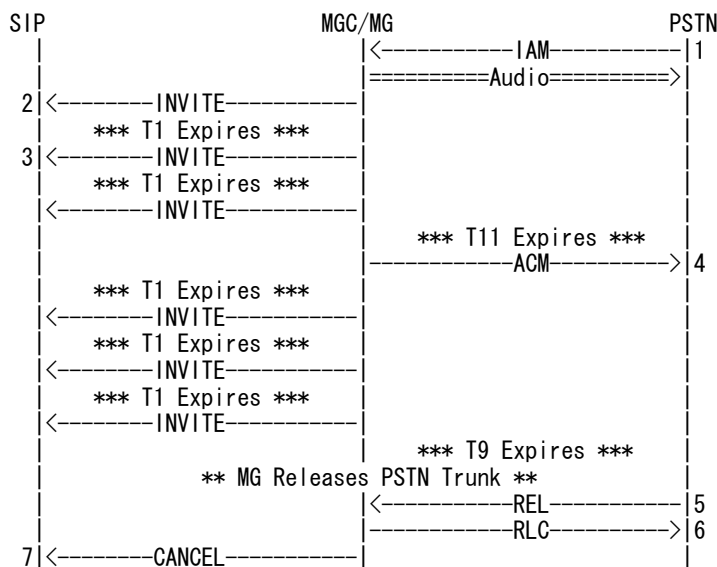

1. When a PSTN user wishes to begin a session with a SIP user, the PSTN network generates an IAM message towards the gateway.
2. Upon receipt of the IAM message, the gateway generates an INVITE message, and sends it to an appropriate SIP node based on called number analysis. The ISUP timer T11 and SIP timer T1 are set at this time.

From "RFC3398"
(C) The Internet
Society

3. The INVITE message will continue to be sent to the SIP node each time the timer T1 expires. The SIP standard specifies that INVITE transmission will be performed 7 times if no response is received. Since SIP T1 starts at 1/2 second or more and doubles each time it is retransmitted, it will be at least a minute before SIP times out the INVITE request; since SIP T1 is allowed to be larger than 500 ms initially, it is possible that 7 x SIP T1 will be longer than ISUP T11 + ISUP T9.
4. When T11 expires, an ACM message will be sent to the ISUP node to prevent the call from being torn down by the remote node's ISUP T7. This ACM contains a 'Called Party Status' value of 'no indication.'
5. When ISUP T9 in the remote PSTN node expires, it will send a REL.
6. Upon receipt of the REL, the gateway will send an RLC to acknowledge.
7. The REL will trigger a CANCEL request, which gets sent to the SIP node.

From "RFC3398"
(C) The Internet
Society

▲
T9 タイマは適用されないため、本節の手順中の T9 タイマ満了によって MGC が切断メッセージ (REL) を受信することはない。

8.1.5 SIP Error Response

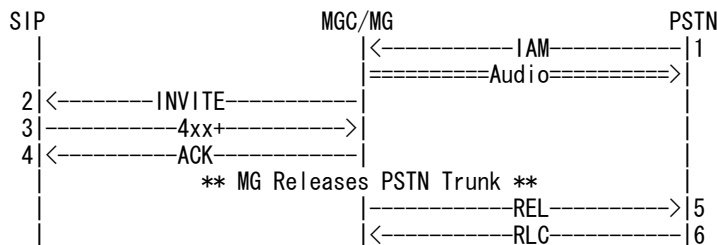

1. When a PSTN user wishes to begin a session with a SIP user, the PSTN network generates an IAM message towards the gateway.
2. Upon receipt of the IAM message, the gateway generates an INVITE message, and sends it to an appropriate SIP node based on called number analysis.
3. The SIP node indicates an error condition by replying with a response with a code of 400 or greater.
4. The gateway sends an ACK message to acknowledge receipt of the INVITE final response.

From "RFC3398"
(C) The Internet
Society

5. An ISUP REL message is generated from the SIP code, as specified in Section 8.2.6.1.
6. The remote ISUP node confirms receipt of the REL message with an RLC message.

8.1.6 SIP Redirection

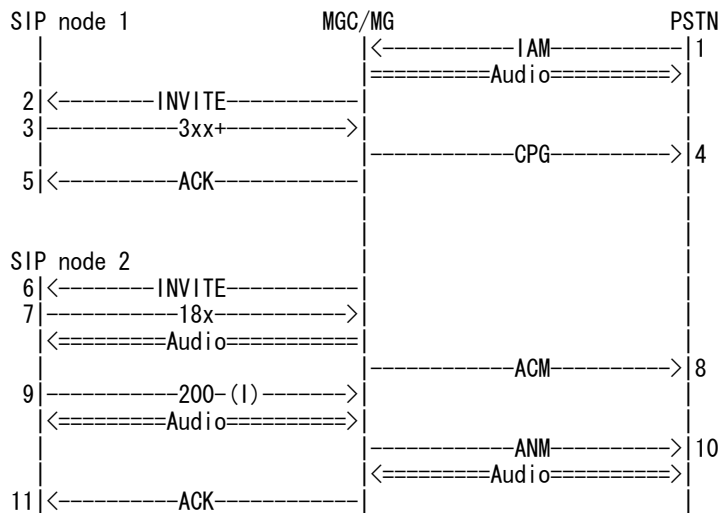

1. When a PSTN user wishes to begin a session with a SIP user, the PSTN network generates an IAM message towards the gateway.
2. Upon receipt of the IAM message, the gateway generates an INVITE message, and sends it to an appropriate SIP node based on called number analysis.
3. The SIP node indicates that the resource which the user is attempting to contact is at a different location by sending a 3xx message. In this instance we assume the Contact URL specifies a valid URL reachable by a VoIP SIP call.
4. The gateway sends a CPG with event indication that the call is being forwarded upon receipt of the 3xx message. Note that this translation should be able to be disabled by configuration, as some ISUP nodes do not support receipt of CPG messages before ACM messages.
5. The gateway acknowledges receipt of the INVITE final response by sending an ACK message to the SIP node.

From "RFC3398"
 (C) The Internet
 Society

6. The gateway re-sends the INVITE message to the address indicated in the Contact: field of the 3xx message.
7. When an event signifying that the call has sufficient addressing information occurs, the SIP node will generate a provisional response of 180 or greater.
8. Upon receipt of a provisional response of 180 or greater, the gateway will generate an ACM message with an event code as indicated in Section 8.2.3.
9. When the SIP node answers the call, it will send a 200 OK message.
10. Upon receipt of the 200 OK message, the gateway will send an ANM message towards the ISUP node.
11. The gateway will send an ACK to the SIP node to acknowledge receipt of the INVITE final response.

8.1.7 Call Canceled by ISUP

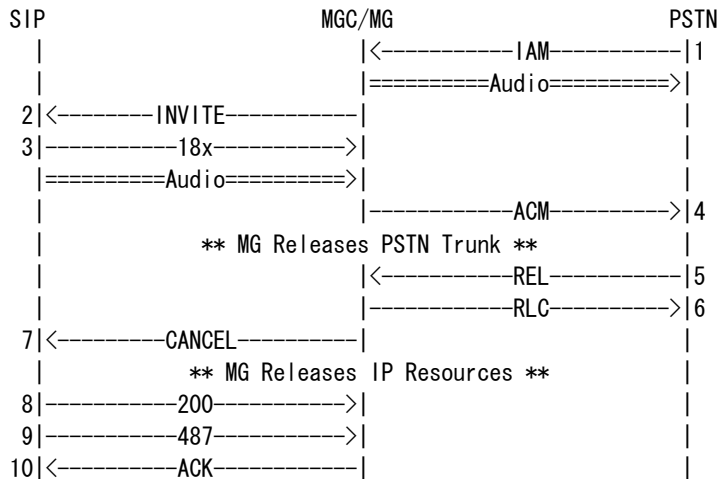

1. When a PSTN user wishes to begin a session with a SIP user, the PSTN network generates an IAM message towards the gateway.
2. Upon receipt of the IAM message, the gateway generates an INVITE message, and sends it to an appropriate SIP node based on called number analysis.
3. When an event signifying that the call has sufficient addressing information occurs, the SIP node will generate a provisional response of 180 or greater.

4. Upon receipt of a provisional response of 180 or greater, the gateway will generate an ACM message with an event code as indicated in Section 8.2.3.
5. If the calling party hangs up before the SIP node answers the call, a REL message will be generated.
6. The gateway frees the PSTN circuit and indicates that it is available for reuse by sending an RLC.
7. Upon receipt of a REL message before an INVITE final response, the gateway will send a CANCEL towards the SIP node.
8. Upon receipt of the CANCEL, the SIP node will send a 200 response.
9. The remote SIP node will send a "487 Call Cancelled" to complete the INVITE transaction.
10. The gateway will send an ACK to the SIP node to acknowledge receipt of the INVITE final response.

8.2 State Machine

Note that REL may arrive in any state. Whenever this occurs, the actions in section Section 8.2.7. are taken. Not all of these transitions are shown in this diagram.

From "RFC3398"
(C) The Internet Society

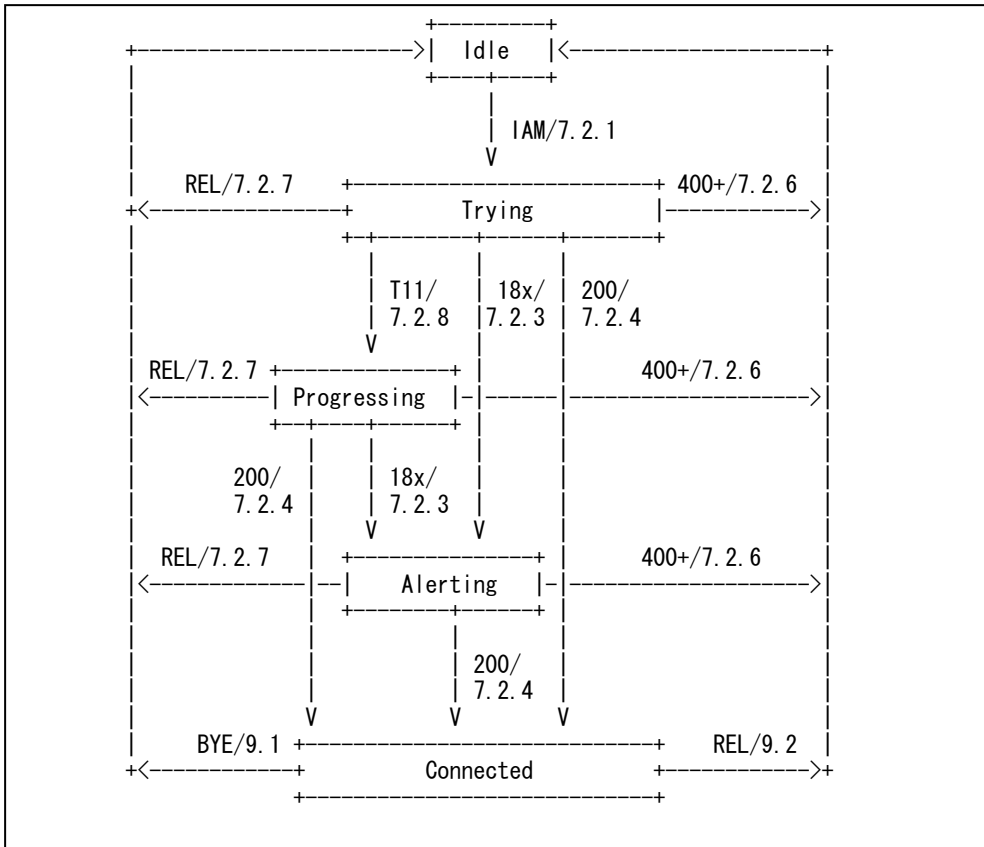

From "RFC3398"
(C) The Internet Society



Note: 原文では上図中の対応する章節がずれているため、本標準では適切な章節番号で修正している。

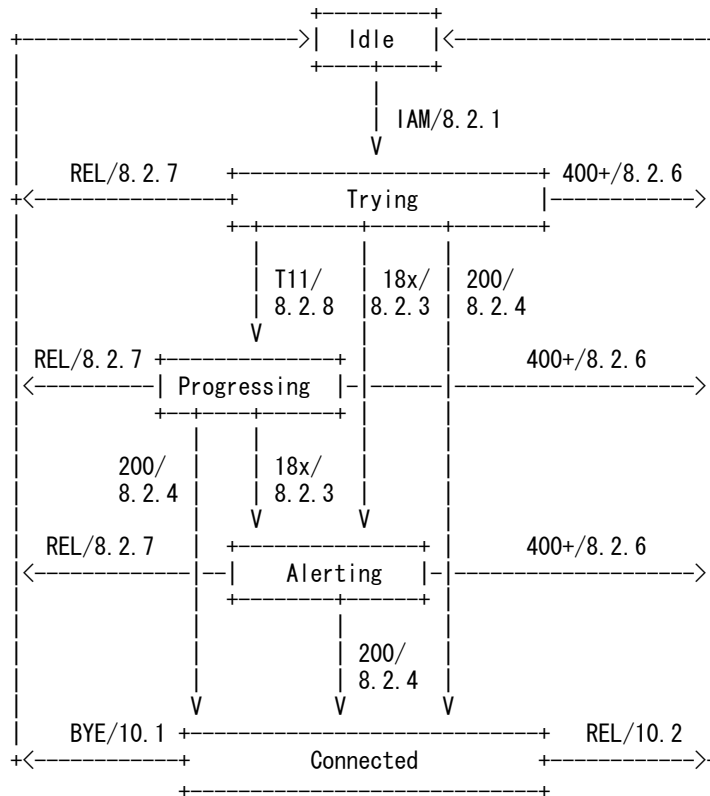

8.2.1 Initial Address Message received

Upon receipt of an IAM, the gateway SHOULD reserve appropriate internal resources (Digital Signal Processors – DSPs – and the like) necessary for handling the IP side of the call. It MAY make any necessary preparations to connect audio in the backwards direction (towards the caller).

8.2.1.1 IAM to INVITE procedures

When an IAM arrives at a PSTN-SIP gateway, a SIP INVITE message MUST be created for transmission to the SIP network. This section details the process by which a gateway populates the fields of the INVITE based on parameters found within the IAM.

The context of the call setup request read by the gateway in the IAM will be mapped primarily to two URIs in the INVITE, one representing the originator of the session and the other its destination. The former will always appear in the From header (after it has been converted from ISUP format by the procedure described in Section 12), and the latter is almost always used for both the To header and the Request-URI.

From "RFC3398"
(C) The Internet
Society

Once the address of the called party number has been read from the IAM, it SHOULD be translated into a destination tel URL that will serve as the Request-URI of the INVITE. Alternatively, a gateway MAY first attempt a Telephone Number Mapping (ENUM) [8] query to resolve the called party number to a URI. Some additional ISUP fields MAY be added to the tel URL after translation has been completed, namely:

- o If the gateway supports carrier-based routing (which is optional in this specification), it SHOULD ascertain if either the CIP (in ANSI networks) or TNS parameter is present in the IAM. If a value is present, the CIC SHOULD be extracted from the given parameter and analyzed by the gateway. A 'cic=' field with the value of the CIC SHOULD be appended to the destination tel URL, if doing so is in keeping with local policy (i.e., provided that the CIC does not indicate the network which owns the gateway or some similar condition). Note that if it is created, the 'cic=' parameter MUST be prefixed with the country code used or implied in the called party number, so that CIC '5062' becomes, in the United States, '+1-5062'. For further information on the 'cic=' tel URL field see [21].
- o If the gateway supports number portability-based routing (which is optional in this specification), then the gateway will need to look at a few other fields. To correctly map the FCI 'number translated' bit indicating that an LNP dip had been performed in the PSTN, an 'npdi=yes' field SHOULD be appended to the tel URL. If a GAP is present in the IAM, then the contents of the CPN (the Location Routing Number - LRN) SHOULD be translated from ISUP format (as described in Section 12) and copied into an 'rn=' field which must be appended to the tel URL, whereas the GAP itself should be translated to ISUP format and used to populate the primary telephone number field of the tel URL. Note that in some national numbering plans, both the LRN and the dialed number may

From "RFC3398"
(C) The Internet
Society

be stored in the CPN parameter, in which case they must be separated out into different fields to be stored in the tel URL. Note that LRNs are necessarily national in scope, and consequently they MUST NOT be preceded by a '+' in the 'rn=' field. For further information on these tel URL fields see [21].

In most cases, the resulting destination tel URL SHOULD be used in both the To field and Request-URI sent by the gateway. However, if the OCN parameter is present in the IAM, the To field SHOULD be constructed from the translation (from ISUP format following Section 12 of the OCN parameter, and hence the Request-URI and To field MAY be different.

From "RFC3398"
(C) The Internet
Society

▲
ANSI 特有の動作を規定しており、TTCにおいて相当する動作については本標準では規定しない。

The construction of the From header field is dependent on the presence of a CIN parameter. If the CIN is not present, then the gateway SHOULD create a dummy From header field containing a SIP URI without a user portion which communicates only the hostname of the gateway (e.g., 'sip:gw.sipcarrier.com). If the CIN is available, then it SHOULD be translated (in accordance with the procedure described above) into a tel URL which should populate the From header field. In either case, local policy or requests for presentation restriction (see Section 12.1) MAY result in a different value for the From header field.

8.2.2 100 received

A 100 response SHOULD NOT trigger any PSTN interworking messages: it only serves the purpose of suppressing INVITE retransmissions.

8.2.3 18x received

Upon receipt of a 18x provisional response, if no ACM has been sent and no legitimate and comprehensible ISUP is present in the 18x message body, then the ISUP message SHOULD be generated according to the following table. Note that if an early ACM is sent, the call MUST enter state "Progressing" instead of state "Alerting."

Response received	Message sent by the MGC
180 Ringing	ACM (BCI = subscriber free)
181 Call is being forwarded	Early ACM and CPG, event=6
182 Queued	ACM (BCI = no indication)
183 Session progress message	ACM (BCI = no indication)

If an ACM has already been sent and no ISUP is present in the 18x message body, an ISUP message SHOULD be generated according to the following table.

Response received	Message sent by the MGC
180 Ringing	CPG, event = 1 (Alerting)
181 Call is being forwarded	CPG, event = 6 (Forwarding)
182 Queued	CPG, event = 2 (Progress)
183 Session progress message	CPG, event = 2 (Progress)

Upon receipt of a 180 response, the gateway SHOULD generate the ringback tone to be heard by the caller on the PSTN side (unless the gateway knows that ringback will be provided by the network on the PSTN side).

From "RFC3398"
(C) The Internet Society

Note however that a gateway might receive media at any time after it has transmitted an SDP offer that it has sent in an INVITE, even before a 18x provisional response is received. Therefore the gateway MUST be prepared to play this media to the caller on the PSTN side (if necessary, ceasing any ringback tone that it may have begun to generate and then playing media). Note that the gateway may also receive SDP offers in responses for an early media session using some SIP extension, see Section 5.5. If a gateway receives a 183 response while it is playing backwards media, then when it generates a mapping for this response, if no encapsulated ISUP is present, the gateway SHOULD indicate that in-band information is available (for example, with the Event Information parameter of the CPG message or the Optional Backward Call Indicators parameter of the ACM).

From "RFC3398"
(C) The Internet Society

▲
本仕様の範囲においては、MGC/MGを管理する事業者 SIP 網と同一もしくは応答前音源接続の合意のある事業者 SIP 網内にあって、第三者であるユーザ等が音源を操作できないことが保証されるノードからのメディアであることが判断可能である場合を除いて、2xx レスポンス受信前に逆方向パスを接続してはいけない。
▼

When an ACM is sent, the mandatory Backward Call Indicators parameter must be set, as well as any optional parameters as gateway policy dictates. If legitimate and comprehensible ISUP is present in the 18x response, the gateway SHOULD re-use the appropriate parameters of the ISUP message contained in the response body, including the value of the Backward Call Indicator parameter, as it formulates a message that it will send across its PSTN interface. In the absence of a usable encapsulated ACM, the BCI parameter SHOULD be set as follows:

From "RFC3398"
(C) The Internet Society

Message type:	ACM
Backward Call Indicators	
Charge indicator:	10 charge
Called party's status indicator:	01 subscriber free or 00 no indication
Called party's category indicator:	01 ordinary subscriber
End-to-end method indicator:	00 no end-to-end method
Interworking indicator:	0 no interworking
End-to-end information indicator:	0 no end-to-end info
ISDN user part indicator:	1 ISUP used all the way
Holding indicator:	0 no holding
ISDN access indicator:	0 No ISDN access
Echo control device indicator:	It depends on the call
SCCP method indicator:	00 no indication

From "RFC3398"
(C) The Internet
Society

▲
アドレス完了メッセージ(ACM) (および応答メッセージ(ANM))に含まれるISDNアクセス表示の設定は、事業者SIP網が自己の管理するユーザへ提供するサービスレベルに基づき決定される。その他のパラメータに関しては、ISDNアクセス表示の設定により設定基準が異なる。“着側のユーザ・網インタフェースが非ISDN”を適用する場合のアドレス完了メッセージ(ACM)、(および応答メッセージ(ANM))に設定される主要パラメータのデフォルト設定値を付属資料 aの a.2節に、留意点を付属資料 bに示す。また、“着側のユーザ・網インタフェースがISDN”を適用する場合は、JT-Q699[8]に従うこととし、JT-Q699[8]未規定部分は付属資料 aのa.2節の記載に従う。

Note that when the ISUP Backward Call Indicator parameter Interworking indicator field is set to 'interworking encountered', this indicates that ISDN is interworking with a network which is not capable of providing as many services as ISDN does. ISUP therefore may not employ certain features it otherwise normally uses. Gateway vendors MAY however provide a configurable option, usable at the discretion of service providers when they require additional ISUP services, that in the absence of encapsulated ISUP will signal in the BCI that interworking has been encountered, and that ISUP is not used all the way, for those operators that as a matter of policy would rather operate in this mode. For more information on the effects of interworking see Section 7.2.1.1.

8.2.4 2xx received

Response received	Message sent by the MGC
-----	-----
200 OK	ANM, ACK

After receiving a 200 OK response the gateway MUST establish a directional media path in the gateway and send an ANM to the PSTN as well as an ACK to the SIP network.

From "RFC3398"
(C) The Internet
Society

▼
If the 200 OK response arrives before the gateway has sent an ACM, a CON is sent instead of the ANM, in those ISUP variants that support the CON message.

From "RFC3398"
(C) The Internet
Society

▲
(JJ-90.10 注) 接続メッセージ(CON)の送出が許容されないため、アドレス完了メッセージ(ACM)および応答メッセージ(ANM)の2つのメッセージにマッピングを行う。詳細については8.1.2節参照。

When a legitimate and comprehensible ANM is encapsulated in the 200 OK response, the gateway SHOULD re-use any relevant ISUP parameters in the ANM it sends to the PSTN.

Gamarillo, et. al.

Standards Track

[Page 43]

From "RFC3398"
(C) The Internet
Society

Note that gateways may sometimes receive 200 OK responses for requests other than INVITE (for example, those used in managing provisional responses, or the INFO method). The procedures described in this section apply only to 200 OK responses received as a result of sending an INVITE. The gateway SHOULD NOT send any PSTN messages if it receives a 200 OK in response to non-INVITE requests it has sent.

8.2.5 3xx Received

When any 3xx response (a redirection) is received, the gateway SHOULD try to reach the destination by sending one or more new call setup requests using URIs found in any Contact header field(s) present in the response, as is mandated in the base SIP specification. Such 3xx responses are typically sent by a redirect server, and can be thought of as similar to a location register in mobile PSTN networks.

If a particular URI presented in the Contact header of a 3xx is best reachable (according to the gateway's routing policies) via the PSTN, the gateway SHOULD send a new IAM and from that moment on act as a normal PSTN switch (no SIP involved) – usually this will be the case when the URI in the Contact header is a tel URL, one that the gateway cannot reach locally and one for which there is no ENUM mapping.

Alternatively, the gateway MAY send a REL message to the PSTN with a redirection indicator (23) and a diagnostic field corresponding to the telephone number in the URI. If, however, the new location is best reachable using SIP (if the URI in the Contact header contains no telephone number at all), the MGC SHOULD send a new INVITE with a Request-URI possibly a new IAM generated by the MGC in the message body.

While it is exploring a long list of Contact header fields with SIP requests, a gateway MAY send a CPG message with an event code of 6 (Forwarding) to the PSTN in order to indicate that the call is proceeding (where permitted by the ISUP variant in question).

All redirection situations have to be treated very carefully because they involved special charging situations. In PSTN the caller typically pays for the first leg (to the gateway) and the callee pays the second (from the forwarding switch to the destination).

8.2.6 4xx-6xx Received

When a response code of 400 or greater is received by the gateway, then the INVITE previously sent by the gateway has been rejected. Under most circumstances the gateway SHOULD release the resources in the gateway, send a REL to the PSTN with a cause value and send an

ACK to the SIP network. Some specific circumstances are identified below in which a gateway MAY attempt to rectify a SIP-specific problem communicated by a status code without releasing the call by retrying the request. When a REL is sent to the PSTN, the gateway expects the arrival of an RLC indicating that the release sequence is complete.

8.2.6.1 SIP Status Code to ISDN Cause Code Mapping

When a REL message is generated due to a SIP rejection response that contains an encapsulated REL message, the Cause Indicator (CAI) parameter in the generated REL SHOULD be set to the value of the CAI parameter received in the encapsulated REL. If no encapsulated ISUP is present, the mapping below between status code and cause codes are RECOMMENDED.

Any SIP status codes not listed below (associated with SIP extensions, versions of SIP subsequent to the issue of this document, or simply omitted) should be mapping to cause code 31 "Normal, unspecified". These mappings cover only responses; note that the BYE and CANCEL requests, which are also used to tear down a dialog, SHOULD be mapped to 16 "Normal clearing" under most circumstances (although see Section 5.8).

By default, the cause location associated with the CAI parameter should be encoded such that 6xx codes are given the location 'user', whereas 4xx and 5xx codes are given a 'network' location. Exceptions are marked below.

Just as there are certain ISDN cause codes that are ISUP-specific and have no corollary SIP action, so there are SIP status codes that should not simply be translated to ISUP - some SIP-specific action should be attempted first. See the note on the (+) tag below.

From "RFC3398"
(C) The Internet
Society

Response received	Cause value in the REL
400 Bad Request	41 Temporary Failure
401 Unauthorized	21 Call rejected (*)
402 Payment required	21 Call rejected
403 Forbidden	21 Call rejected
404 Not found	1 Unallocated number
405 Method not allowed	63 Service or option unavailable
406 Not acceptable	79 Service/option not implemented (+)
407 Proxy authentication required	21 Call rejected (*)
408 Request timeout	102 Recovery on timer expiry
410 Gone	22 Number changed (w/o diagnostic)
413 Request Entity too long	127 Interworking (+)
414 Request-URI too long	127 Interworking (+)
415 Unsupported media type	79 Service/option not implemented (+)
416 Unsupported URI Scheme	127 Interworking (+)
420 Bad extension	127 Interworking (+)
421 Extension Required	127 Interworking (+)
423 Interval Too Brief	127 Interworking (+)
480 Temporarily unavailable	18 No user responding
481 Call/Transaction Does not Exist	41 Temporary Failure
482 Loop Detected	25 Exchange - routing error
483 Too many hops	25 Exchange - routing error
484 Address incomplete	28 Invalid Number Format (+)
485 Ambiguous	1 Unallocated number
486 Busy here	17 User busy
487 Request Terminated	--- (no mapping)
488 Not Acceptable here	--- by Warning header
500 Server internal error	41 Temporary failure
501 Not implemented	79 Not implemented, unspecified
502 Bad gateway	38 Network out of order
503 Service unavailable	41 Temporary failure
504 Server time-out	102 Recovery on timer expiry
504 Version Not Supported	127 Interworking (+)
513 Message Too Large	127 Interworking (+)
600 Busy everywhere	17 User busy
603 Decline	21 Call rejected
604 Does not exist anywhere	1 Unallocated number
606 Not acceptable	--- by Warning header

From "RFC3398"
(C) The Internet
Society

▲ ISUP側の理由表示値#1 は欠番を意味するものであり、Reasonヘッダ (Q. 850: cause=1) [11] を付加した 404 レスポンスからマッピングされる。それ以外のSIPレスポンスからの理由表示値#1 へのマッピングには注意が必要である。

理由表示値のマッピングに関しては、基本的に各事業者マターであり、上記は推奨値として用いる。

TTC ISUP においては本節に記述されるすべての理由表示値を規定しているわけではない。TTC ISUP において規定されていない理由表示値のマッピングについては今後整理される必要がある。

(*) In some cases, it may be possible for a SIP gateway to provide credentials to the SIP UAS that is rejecting an INVITE due to authorization failure. If the gateway can authenticate itself, then obviously it SHOULD do so and proceed with the call; only if the gateway cannot authenticate itself should cause code 21 be sent.

(+) If at all possible, a SIP gateway SHOULD respond to these protocol errors by remedying unacceptable behavior and attempting to re-originate the session. Only if this proves impossible should the SIP gateway fail the ISUP half of the call.

When the Warning header is present in a SIP 606 or 488 message, there may be specific ISDN cause code mappings appropriate to the Warning code. This document recommends that '31 Normal, unspecified' SHOULD by default be used for most currently assigned Warning codes. If the Warning code speaks to an unavailable bearer capability, cause code '65 Bearer Capability Not Implemented' is a RECOMMENDED mapping.

8.2.7 REL Received

This circumstance generally arises when the user on the PSTN side hangs up before the call has been answered; the gateway therefore aborts the establishment of the session. A CANCEL request MUST be issued (a BYE is not used, since no final response has arrived from the SIP side). A 200 OK for the CANCEL can be expected by the gateway, and finally a 487 for the INVITE arrives (which the gateway ACKs in turn).

The gateway SHOULD store state information related to this dialog for a certain period of time, since a 200 final response for the INVITE originally sent might arrive (even after the reception of the 200 OK for the CANCEL). In this situation, the gateway MUST send an ACK followed by an appropriate BYE request.

In SIP bridging situations, the REL message cannot be encapsulated in a CANCEL message (since CANCEL cannot have a message body). Usually, the REL message will contain a CAI value of 16 "Normal clearing". If the value is other than a 16, the gateway MAY wish to use some other means of communicating the cause value (see Section 5.8).

8.2.8 ISUP T11 Expires

In order to prevent the remote ISUP node's timer T7 from expiring, the gateway MAY keep its own supervisory timer; ISUP defines this timer as T11. T11's duration is carefully chosen so that it will always be shorter than the T7 of any node to which the gateway is communicating.

To clarify timer T11's relevance with respect to SIP interworking, Q. 764 [12] explains its use as: "If in normal operation, a delay in the receipt of an address complete signal from the succeeding network is expected, the last common channel signaling exchange will originate and send an address complete message 15 to 20 seconds [timer (T11)] after receiving the latest address message." Since SIP nodes have no obligation to respond to an INVITE request within 20 seconds, SIP interworking inarguably qualifies as such a situation.

If the gateway supports this optional mechanism, then if its T11 expires, it SHOULD send an early ACM (i.e., called party status set to "no indication") to prevent the expiration of the remote node's T7 (where permitted by the ISUP variant). See Section 8.2.3 for the value of the ACM parameters.

If a "180 Ringing" message arrives subsequently, it SHOULD be sent in a CPG, as shown in Section 8.2.3.

See Section 8.1.3 for an example callflow that includes the expiration of T11.

9. Suspend/Resume and Hold

9.1 Suspend (SUS) and Resume (RES) Messages

In ISDN networks, a user can generate a SUS (timer T2, user initiated) in order to unplug the terminal from the socket and plug it in another one. A RES is sent once the terminal has been reconnected and the T2 timer has not expired. SUS is also frequently used to signaling an on-hook state for a remote terminal before timers leading to the transmission of a REL message are sent (this is the more common case by far).

From "RFC3398"
(C) The Internet Society

▼

While a call is suspended, no audio media is passed end-to-end.

From "RFC3398"
(C) The Internet Society

▲

ただし、ISDN 区間ではパスは保持し続け、パスの開閉は MG や PSTN 上の発着交換機で行うこととなる。

When a SUS is sent for a call that has a SIP leg, a gateway MAY suspend IP media transmission until a RES is received. Putting the media on hold insures that bandwidth is conserved when no audio traffic needs to be transmitted.

If media suspension is appropriate, then when a SUS arrives from the PSTN, the MGC MAY send an INVITE to request that the far-end's transmission of the media stream be placed on hold. The subsequent reception of a RES from the PSTN SHOULD then trigger a re-INVITE that requests the resumption of the media stream. Note that the MGC may or may not elect to stop transmitting any media itself when it requests the cessation of far-end transmission.

From "RFC3398"
(C) The Internet Society

If media suspension is not required by the MGC receiving the SUS from the PSTN, the SIP INFO [6] method MAY be used to transmit an encapsulated SUS rather than a re-INVITE. Note that the recipient of such an INFO request may be a simple SIP phone that does not understand ISUP (and would therefore take no action on receipt of this message); if a prospective destination for an INFO-encapsulated SUS has not used encapsulated ISUP in any messages it has previously sent, the gateway SHOULD NOT relay the INFO method, but rather should handle the SUS and the corresponding RES without signaling their arrival to the SIP network.

In any case, subsequent RES messages MUST be transmitted in the same method that was used for the corresponding SUS (i.e., if an INFO is used for a SUS, INFO should also be used for the subsequent RES).

Regardless of whether the INFO or re-INVITE mechanism is used to carry a SUS message, neither has any implication that the originating side will cease sending IP media. The recipient of an encapsulated SUS message MAY therefore elect to send a re-INVITE themselves to suspend media transmission from the MGC side if desired.

The following example uses the INVITE mechanism. Note that this flow is informative, not proscriptive; compliant gateways are free to implement functionally equivalent flows, as described in the preceding paragraphs.

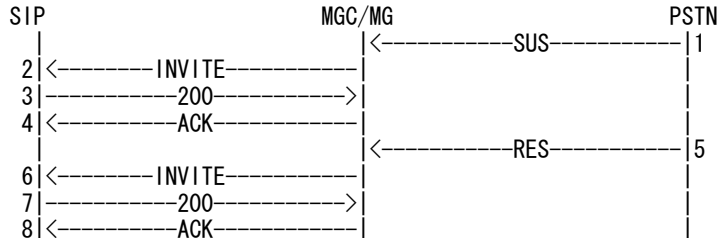

The handling of a network-initiated SUS immediately prior to call teardown is handled in Section 10.2.2.

9.2 Hold (re-INVITE)



After a call has been connected, a re-INVITE could be sent to a gateway from the SIP side in order to place the call on hold. This re-INVITE will have an SDP offer indicating that the originator of the re-INVITE no longer wishes to receive media.

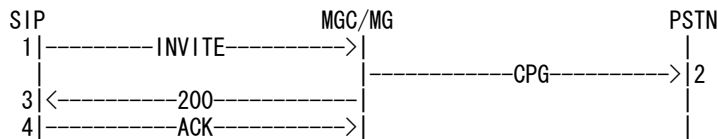

When such a re-INVITE is received, the gateway SHOULD send a CPG in order to express that the call has been placed on hold. The CPG SHOULD contain a Generic Notification Indicator (or, in ANSI networks, a Notification Indicator) with a value of 'remote hold'.

If, subsequent to the sending of the re-INVITE, the SIP side wishes to take the remote end off hold and begin receiving media again, it SHOULD repeat the flow above with an INVITE that contains an SDP offer with an appropriate media destination. The Generic Notification Indicator would in this instance have a value of 'remote retrieval' (or in some variants 'remote hold released').

Finally, note that a CPG with hold indicators may be received by a gateway from the PSTN. In the interests of conserving bandwidth, the gateway SHOULD stop sending media until the call is resumed and SHOULD send a re-INVITE to the SIP leg of the call requesting that the remote side stop sending media.



(JJ-90.10 注) 汎用通知パラメータは規定されておらず、本節の保留に関する手順についてもサポートされない。したがって、PSTN 側メッセージへのマッピングも行わない。左記の制約に関わらず SIP 網側において音声パケット送受の停止を行う場合には上図の通り 200 OK レスポンスを返送することが推奨される。また、音声パケット送受の停止を行わない場合には 488 レスポンスを返送し、MGC においては呼を継続することが推奨される。なお、上記を含めてパス接続に関しては各事業者マターである。

10. Normal Release of the Connection

From the perspective of a gateway, either the SIP side or the ISUP side can release a call, regardless of which side initiated the call. Note that cancellation of a call setup request (either from the ISUP or SIP side) is discussed elsewhere in this document (in Section 8.2.7 and Section 7.2.3, respectively).

Gateways SHOULD implement functional equivalence with the flows in this section.

10.1 SIP initiated release

For a normal termination of the dialog (receipt of a BYE request), the gateway **MUST** immediately send a 200 response. The gateway then **MUST** release any media resources in the gateway (DSPs, TCIC locks, and so on) and send an REL with a cause code of 16 (normal call

clearing) to the PSTN. Release of resources is confirmed by the PSTN side with an RLC message.

In SIP bridging situations, the cause code of any REL encapsulated in the BYE request SHOULD be re-used in any REL that the gateway sends to the PSTN.

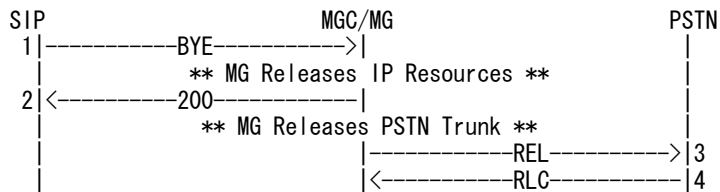

10.2 ISUP initiated release

If the release of the connection was caused by the reception of a REL, the REL SHOULD be encapsulated in the BYE sent by the gateway. Whether the caller or callee hangs up first, the gateway SHOULD release any internal resources used in support of the call and then MUST confirm that the circuit is ready for re-use by sending an RLC.

10.2.1 Caller hangs up

When the caller hangs up, the SIP dialog MUST be terminated by sending a BYE request (which is confirmed with a 200).

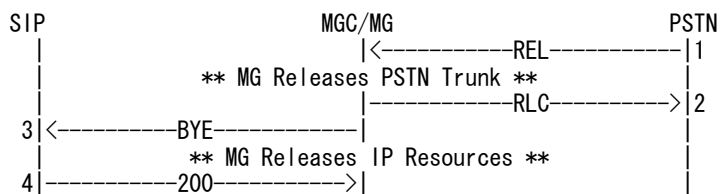

10.2.2 Callee hangs up (SUS)

From "RFC3398"
(C) The Internet
Society

In some PSTN scenarios, if the callee hangs up in the middle of a call, the local exchange sends a SUS instead of a REL and starts a timer (T6, SUS is network initiated). When the timer expires, the REL is sent. This necessitates a slightly different SIP flow; see Section 9 for more information on handling suspension. It is RECOMMENDED that gateways implement functional equivalence with the following flow for this case:

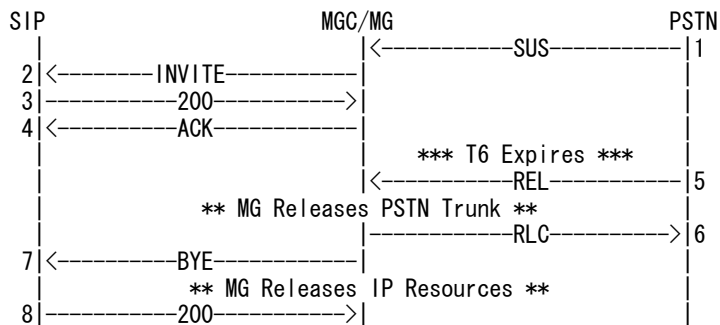

From "RFC3398"
(C) The Internet
Society

一般的には、中断メッセージ(SUS)受信側においても T6 タイマは起動される。したがって、MGC においても中断メッセージ(SUS)受信を契機に T6 を開始するべきである(その際には、T6 満了時、SIP 側に BYE リクエストを送出し、ISUP 側に切断メッセージ(REL)を送出する)。

また、図中の中断メッセージ(SUS)からre-INVITEリクエストへのマッピングについては、9.1 節にもある通り、必ずしもre-INVITEリクエストへのマッピングを行う必要はない。

11. ISUP Maintenance Messages

ISUP contains a set of messages used for maintenance purposes. They can be received during any ongoing call. There are basically two kinds of maintenance messages (apart from the continuity check): messages for blocking circuits and messages for resetting circuits.

11.1 Reset messages

Upon reception of an RSC message for a circuit currently being used by the gateway for a call, the call MUST be released immediately (this typically results from a serious maintenance condition). RSC MUST be answered with an RLC after resetting the circuit in the gateway. Group reset (GRS) messages which target a range of circuits are answered with a Circuit Group Reset ACK Message (GRA) after resetting all the circuits affected by the message.

The gateways SHOULD behave as if a REL had been received in order to release the dialog on the SIP side. A BYE or a CANCEL are sent depending of the status of the call. See the procedures in Section 10.

From "RFC3398"
(C) The Internet
Society

11.2 Blocking messages

There are two kinds of blocking messages: maintenance messages or hardware-failure messages. Maintenance blocking messages indicate that the circuit is to be blocked for any subsequent calls, but these messages do not affect any ongoing call. This allows circuits to be gradually quiesced and taken out of service for maintenance.

Hardware-oriented blocking messages have to be treated as reset messages. They generally are sent only when a hardware failure has occurred. Media transmission for all calls in progress on these circuits would be affected by this hardware condition, and therefore all calls must be released immediately.

BLO is always maintenance oriented and it is answered by the gateway with a Blocking ACK Message (BLA) when the circuit is blocked - this requires no corresponding SIP actions. Circuit Group Blocking (CGB) messages have a "type indicator" inside the Circuit Group Supervision Message Type Indicator. It indicates if the CGB is maintenance or hardware failure oriented. If the CGB results from a hardware failure, then each call in progress in the affected range of circuits MUST be terminated immediately as if a REL had been received, following the procedures in Section 10. CGBs MUST be answered with CGBAs.

11.3 Continuity Checks

A continuity check is a test performed on a circuit that involves the reflection of a tone generated at the originating switch by a loopback at the destination switch. Two variants of the continuity check appear in ISUP: the implicit continuity check request within an IAM (in which case the continuity check takes place as a precondition before call setup begins),

From "RFC3398"
(C) The Internet
Society

and the explicit continuity check signaled by a Continuity Check Request (CCR) message. PSTN gateways in regions that support continuity checking generally SHOULD have some way of accommodating these tests (if they hope to be fielded by providers that interconnect with any major carrier).

When a CCR is received by a PSTN-SIP gateway, the gateway SHOULD NOT send any corresponding SIP messages; the scope of the continuity check applies only to the PSTN trunks, not to any IP media paths beyond the gateway. CCR messages also do not designate any called party number, or any other way to determine what SIP user agent server should be reached.

From "RFC3398"
(C) The Internet
Society

導通試験要求メッセージ(CCR)は適用されないため、上記の手順をサポートする必要はない。



When an IAM with the Continuity Check Indicator flag set within the NCI parameter is received, the gateway **MUST** process the continuity check before sending an INVITE message (and proceeding normally with

Gamarillo, et. al.

Standards Track

[Page 53]

From "RFC3398"
(C) The Internet
Society

call setup); if the continuity check fails (a COT with Continuity Indicator of 'failed' is received), then an INVITE MUST NOT be sent.

From "RFC3398"
(C) The Internet
Society

▲
(JJ-90.10注) 導通試験は実施されない。

12. Construction of Telephony URIs

From "RFC3398"
(C) The Internet
Society

発番号表示関連サービスをPSTNと事業者SIP網との間で提供するための、TTC ISUP上の関連要素(発番号パラメータと汎用番号パラメータ)とSIP上の要素(P-Asserted-IdentityヘッダおよびPrivacyヘッダ)との完全なマッピングについては、JJ-90.22[10]で記述される動作に従うこと。

SIP proxy servers MAY route SIP messages on any signaling criteria desired by network administrators, but generally the Request-URI is the foremost routing criterion. The To and From headers are also frequently of interest in making routing decisions. SIP-ISUP mapping assumes that proxy servers are interested in at least these three fields of SIP messages, all of which contain URIs.

SIP-ISUP mapping frequently requires the representation of telephone numbers in these URIs. In some instances these numbers will be presented first in ISUP messages, and SS7-SIP gateways will need to translate the ISUP formats of these numbers into SIP URIs. In other cases the reverse transformation will be required.

The most common format used in SIP for the representation of telephone numbers is the tel URL [7]. When converting between formats, the tel URL MAY constitute the entirety of a URI field in a SIP message, or it MAY appear as the user portion of a SIP URI. For example, a To field might appear as:

To: tel:+17208881000

Or

To: sip:+17208881000@level3.com

Whether or not a particular gateway or endpoint should formulate URIs in the tel or SIP format is a matter of local administrative policy - if the presence of a host portion would aid the surrounding network in routing calls, the SIP format should be used. A gateway MUST accept either tel or SIP URIs from its peers.

The '+' sign preceding the number in tel URLs indicates that the digits which follow constitute a fully-qualified E.164 [16] number; essentially, this means that a country code is provided before any national-specific area codes, exchange/city codes, or address codes. The absence of a '+' sign MAY signify that the number is merely nationally significant, or perhaps that a private dialing plan is in use. When the '+' sign is not present, but a telephone number is represented by the user portion of the URI, the SIP URI SHOULD contain the optional ';user=phone' parameter; e.g.,

To: sip:83000@sip.example.net;user=phone

From "RFC3398"
(C) The Internet
Society

However, it is strongly RECOMMENDED that only internationally significant E.164 numbers be passed between SIP-T gateways, especially when such gateways are in different regions or different administrative domains. In many if not most SIP-T networks, gateways are not responsible for end-to-end routing of SIP calls; practically speaking, gateways have no way of knowing if the call will terminate in a local or remote administrative domain and/or region, and hence gateways SHOULD always assume that calls require an international numbering plan. There is no guarantee that recipients of SIP signaling will be capable of understanding national dialing plans used by the originators of calls - if the originating gateway does not internationalize the signaling, the context in which the digits were dialed cannot be extrapolated by far-end network elements.

In ISUP signaling, a telephone number appears in a common format that is used in several parameters, including the CPN and CIN; when it represents a calling party number it sports some additional information (detailed below). For the purposes of this document, we will refer to this format as 'ISUP format' - if the additional calling party information is present, the format shall be referred to as 'ISUP-calling format'. The format consists of a byte called the Nature of Address (NoA) indicator, followed by another byte which contains the Numbering Plan Indicator (NPI), both of which are prefixed to a variable-length series of bytes that contains the digits of the telephone number in Binary Coded Decimal (BCD) format. In the calling party number case, the NPI's byte also contains bit fields which represent the caller's presentation preferences and the status of any call screening checks performed up until this point in the call.

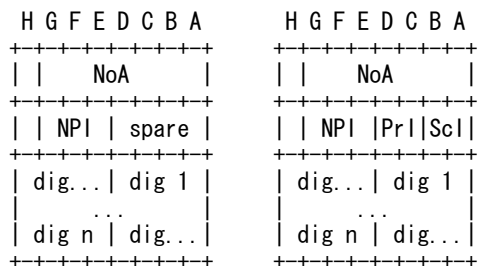

ISUP format

ISUP calling format

ISUP numbering formats

The NPI field is generally set to the value 'ISDN (Telephony) numbering plan (Recommendation E.164)', but this does not mean that the digits which follow necessarily contain a country code; the NoA

field dictates whether the telephone number is in a national or international format. When the represented number is not designated to be in an international format, the NoA generally provides information specific to the national dialing plan – based on this information one can usually determine how to convert the number in question into an international format. Note that if the NPI contains a value other than 'ISDN numbering plan', then the tel URL may not be suitable for carrying the address digits, and the handling for such calls is outside the scope of this document.

From "RFC3398"
(C) The Internet
Society

12.1 ISUP format to tel URL mapping



Based on the above, conversion from ISUP format to a tel URL is as follows. First, provided that the NPI field indicates that the telephone number format uses E.164, the NoA is consulted. If the NoA indicates that the number is an international number, then the telephone number digits SHOULD be appended unmodified to a 'tel:+' string. If the NoA has the value 'national (significant) number', then a country code MUST be prefixed to the telephone number digits before they are committed to a tel URL; if the gateway performing this conversion interconnects with switches homed to several different country codes, presumably the appropriate country code SHOULD be chosen based on the originating switch or trunk group. If the NoA has the value 'subscriber number', both a country code and any other numbering components necessary for the numbering plan in question (such as area codes or city codes) MAY need to be added in order for the number to be internationally significant – however, such procedures vary greatly from country to country, and hence they cannot be specified in detail here. Only if a country or network-specific value is used for the NoA SHOULD a tel URL not include a '+' sign; in these cases, gateways SHOULD simply copy the provided digits into the tel URL and append a 'user=phone' parameter if a SIP URI format is used. Any non-standard or proprietary mechanisms used to communicate further context for the call in ISUP are outside the scope of this document.

From "RFC3398"
(C) The Internet
Society



(JJ-90.10 注) 番号種別は“国内番号”、“国際番号”、“網特有番号”しか使用されない(表 4-4/JJ-90.10)。この場合、ISUP フォーマットから tel URL への変換は次に示される方法で変換されることで、整合性と一意性が確保される。

- “国内番号”の場合は、+81 を先頭に付加する。
- “国際番号”の場合は、そのままの数字に+を付加する。
- “網特有番号”の場合は、番号をそのままマッピングする。

なお本規定は、この他のインプリメンテーションを制限するものではない。また、事業者内での番号情報送受に関しては本標準の規定の範囲外である。



If a nationally-specific parameter is present that allows for the transmission of the calling party's name (such as the Generic Name Parameter in ANSI), then generally, if presentation is not restricted, this information SHOULD be used to populate the display-name portion of the From field.

Gamarillo, et. al.

Standards Track

[Page 56]

From "RFC3398"
(C) The Internet
Society



発信者の名前を示す情報を転送するパラメータは規定されていないため、上記の手順は適用されない。

If ISUP calling format is being converted rather than ISUP format, then two additional pieces of information must be taken into account: presentation indicators and screening indicators. If the presentation indicators are set to 'presentation restricted', then a special URI is created by the gateway which communicates to the far end that the caller's identity has been omitted. This URI SHOULD be a SIP URI with a display-name and username of 'Anonymous', e.g. :

From "RFC3398"
(C) The Internet Society



From: Anonymous <sip:anonymous@anonymous.invalid>

For further information about privacy in SIP, see Section 5.7.

From "RFC3398"
(C) The Internet Society



アドレスメッセージ(IAM)内の発番号パラメータの表示識別が「表示不可」の場合に発信者番号非通知理由パラメータが設定される可能性がある。この場合に着 SIP ユーザにその内容を通知するために displayname を発信者番号非通知理由パラメータの値により、次のように設定してもよい。

- パラメータなし "Unavailable"
- 0000001: ユーザ拒否のため通知不可 "Anonymous"
- 0000010: サービス競合のため通知不可 "Interaction with other service"
- 0000011: 公衆電話発信のため通知不可 "Coin line/payphone"



If presentation is set to 'address unavailable', then gateways should treat the IAM as if the CIN parameter was omitted. Screening indicators should not be translated, as they are only meaningful end-to-end.

From "RFC3398"
(C) The Internet Society



(JJ-90.10 注) 表示識別が「使用不可」で設定されることはない。

12.2 tel URL to ISUP format mapping

Conversion from tel URLs to ISUP format is simpler. If the URI is in international format, then the gateway SHOULD consult the leading country code of the URI. If the country code is local to the gateway (the gateway has one or more trunks that point to switches which are homed to the country code in question), the gateway SHOULD set the NoA to reflect 'national (significant) number' and strip the country code from the URI before populating the digits field. If the country code is not local to the gateway, the gateway SHOULD set the NoA to 'international number' and retain the country code. In either case the NPI MUST be set to 'ISDN numbering plan'.

If the URI is not in international format, the gateway MAY attempt to treat the telephone number within the URI as if it were appropriate to its national or network-specific dialing plan; if doing so gives rise to internal gateway errors or the gateway does not support such procedures, then the gateway SHOULD respond with appropriate SIP status codes to express that the URI could not be understood (if the URI in question is the Request-URI, a 484).

When converting from a tel URL to ISUP calling format, the procedure

From "RFC3398"
(C) The Internet Society

is identical to that described in the preceding paragraphs, but additionally, the presentation indicator SHOULD be set to 'presentation allowed' and the screening indicator to 'network provided',

From "RFC3398"
(C) The Internet
Society



unless some service provider policy or user profile specifically disallows presentation.

Gamarillo, et. al.

Standards Track

[Page 57]

From "RFC3398"
(C) The Internet
Society



発番号パラメータの表示識別を「表示不可」とする場合、併せて発信者番号非通知理由パラメータを適切な内容に設定して送出するべきである。

13. Other ISUP flavors

Other flavors of ISUP different than ITU-T ISUP have different parameters and more features. Some of the parameters have more possible values and provide more information about the status of the call.

The Circuit Query Message (CQM) and Circuit Query Response (CQR) are used in many ISUP variants. These messages have no analog in SIP, although receipt of a CQR may cause state reconciliation if the originating and destination switches have become desynchronized; as states are reconciled some calls may be terminated, which may cause SIP or ISUP messages to be sent (as described in Section 10).

However, differences in the message flows are more important. In ANSI [11] ISUP, the CON message MUST NOT be sent; an ANM is sent instead (when no ACM has been sent before the call is answered). In call forwarding situations, CPGs MAY be sent before the ACM is sent. SAMs MUST NOT be sent; 'en-bloc' signaling is always used. The ANSI Exit Message (EXM) SHOULD NOT result in any SIP signaling in gateways. ANSI also uses the Circuit Reservation Message (CRM) and Circuit Reservation Acknowledgment (CRA) as part of its interworking procedures - in the event that an MGC does receive a CRM, a CRA SHOULD be sent in return (in some implementations, transmissions of a CRA could conceivably be based on a resource reservation system); after a CRA is sent, the MGC SHOULD wait for a subsequent IAM and process it normally. Any further circuit reservation mechanism is outside the scope of this document.

From "RFC3398"
(C) The Internet Society



Although receipt of a Confusion message is an indication of a protocol error, corresponding SIP messages SHOULD NOT be sent on receipt of a CFN - the CFN should be handled with ISUP-specific procedures by the gateway (usually by retransmission of the packet to which the CFN responded). Only if ISUP procedures fails repeatedly should this cause a SIP error condition (and call failure) to arise.

From "RFC3398"
(C) The Internet Society



(JJ-90.10 注) コンフュージョン(CFN)メッセージは使用されない。

In TTC ISUP CPGs MAY be sent before the ACM is sent. Messages such as a Charging Information Message (CHG) MAY be sent between ACM and ANM. 'En-bloc' signaling is always used and there is no T9 timer.

13.1 Guidelines for sending other ISUP messages

Some ISUP variants send more messages than the ones described in this document. Therefore, some guidelines are provided here with regard to transport and mapping of these ISUP message.

From "RFC3398"
(C) The Internet Society

From the caller to the callee, other ISUP messages SHOULD be encapsulated (see [3]) inside INFO messages, even if the INVITE transaction is still not finished. Note that SIP does not ensure that INFO requests are delivered in order, and therefore in adverse network conditions an egress gateway might process INFOs out of order. This issue, however, does not represent an important problem since it is not likely to happen and its effects are negligible in most of the situations.

From "RFC3398"
(C) The Internet
Society



The Information (INF) message and Information Response (INR) are examples of messages that should be encapsulated within an INFO. Gateway implementers might also consider building systems that wait for each INFO transaction to complete before initiating a new INFO transaction.

From the callee to the caller, if a message is received by a gateway before the call has been answered (i.e., ANM is received) it SHOULD be encapsulated in an INFO, provided that this will not be the first SIP message sent in the backwards direction (in which case it SHOULD be encapsulated in a provisional 1xx response). Similarly a message which is received on the originating side (probably in response to an INR) before a 200 OK has been received by the gateway should be carried within an INFO. In order for this mechanism to function properly in the forward direction, any necessary Contact or To-tag must have appeared in a previous provisional response or the message might not be correctly routed to its destination. As such all SIP-T gateways MUST send all provisional responses with a Contact header and any necessary tags in order to enable proper routing of new requests issued before a final response has been received.

From "RFC3398"
(C) The Internet
Society



情報メッセージ(INF)および情報要求メッセージ(INR)は適用されない。ただし、何らかの契機において INFO リクエストの送受を行う場合には、上記の内容については留意されている必要がある。



When the INVITE transaction is finished INFO requests SHOULD also be used in this direction.

Camarillo, et. al.

Standards Track

[Page 59]

From "RFC3398"
(C) The Internet
Society

▲
課金メッセージ(CHG)が着側から転送される可能性がある。その場合、応答メッセージ(ANM)受信前(すなわち、200 OK レスポンス送信前)においては 183 レスポンス内にマッピングを行い、その情報を転送する。応答メッセージ(ANM)受信後(すなわち、200 OK レスポンス送信後)においては INFO リクエスト内にマッピングを行い、その情報を転送する。なお、課金メッセージ(CHG)で示される内容が SIP 網側で必要ないと MGC が判断できる場合、MGC において課金メッセージ(CHG)を破棄してもよい。

14. Acronyms

ACK	Acknowledgment
ACM	Address Complete Message
ANM	Answer Message
ANSI	American National Standards Institute
BLA	Blocking ACK message
BLO	Blocking Message
CGB	Circuit Group Blocking Message
CGBA	Circuit Group Blocking ACK Message
CHG	Charging Information Message
CON	Connect Message
CPG	Call Progress Message
CUG	Closed User Group
GRA	Circuit Group Reset ACK Message
GRS	Circuit Group Reset Message
HLR	Home Location Register
IAM	Initial Address Message
IETF	Internet Engineering Task Force
IP	Internet Protocol
ISDN	Integrated Services Digital Network
ISUP	ISDN User Part
ITU-T	International Telecommunication Union Telecommunication Standardization Sector
MG	Media Gateway
MGC	Media Gateway Controller
MTP	Message Transfer Part
REL	Release Message
RES	Resume Message
RLC	Release Complete Message
RTP	Real-time Transport Protocol
SCCP	Signaling Connection Control Part
SG	Signaling Gateway
SIP	Session Initiation Protocol
SS7	Signaling System No. 7
SUS	Suspend Message
TTC	Telecommunication Technology Committee
UAC	User Agent Client
UAS	User Agent Server
UDP	User Datagram Protocol
VoIP	Voice over IP

15. Security Considerations

The translation of ISUP parameters into SIP headers may introduce some privacy and security concerns above and beyond those that have been identified for other functions of SIP-T [9A]. Merely securing encapsulated ISUP, for example, would not provide adequate privacy

for a user requesting presentation restriction if the Calling Party Number parameter is openly mapped to the From header. Section 12.2 shows how SIP Privacy [9B] should be used for this function. Since the scope of SIP-ISUP mapping has been restricted to only those parameters that will be translated into the headers and fields used to route SIP requests, gateways consequently reveal through translation the minimum possible amount of information.

A security analysis of ISUP is beyond the scope of this document. ISUP bridging across SIP is discussed more fully in [9A], but Section 7.2.1.1 discusses processing the translated ISUP values in relation to any embedded ISUP in a request arriving at PSTN gateway. Lack of ISUP security analysis may pose some risks if embedded ISUP is blindly interpreted. Accordingly, gateways SHOULD NOT blindly trust embedded ISUP unless the request was strongly authenticated [9A], and the sender is trusted, e.g., is another MGC that is authorized to use ISUP over SIP in bridge mode. When requests are received from arbitrary end points, gateways SHOULD filter any received ISUP. In particular, only known-safe commands and parameters should be accepted or passed through. Filtering by deleting believed-to-be dangerous entries does not work well.

In most respects, the information that is translated from ISUP to SIP has no special security requirements. In order for translated parameters to be used to route requests, they should be legible to intermediaries; end-to-end confidentiality of this data would be unnecessary and most likely detrimental. There are also numerous circumstances under which intermediaries can legitimately overwrite the values that have been provided by translation, and hence integrity over these headers is similarly not desirable.

There are some concerns however that arise from the other direction of mapping, the mapping of SIP headers to ISUP parameters, which are enumerated in the following paragraphs. When end users dial numbers in the PSTN today, their selections populate the telephone number portion of the Called Party Number parameter,

From "RFC3398"
(C) The Internet
Society

▼

as well as the digit
portions of the Carrier Identification Code and Transit Network
Selection parameters of an ISUP IAM.

From "RFC3398"
(C) The Internet
Society

▲

CICはANSI特有であるため使用されない。

Similarly, the tel URL and its optional parameters in the Request-URI of a SIP, which can be created directly by end users of a SIP device, map to those parameters at a gateway. However, in the PSTN, policy can prevent the user from dialing certain (invalid or restricted) numbers, or selecting certain carrier identification codes. Thus, gateway operators MAY wish to use corresponding policies to restrict the use of certain tel URLs, or tel URL parameters, when authorizing a call.

From "RFC3398"
(C) The Internet
Society



The fields relevant to number portability, which include in ANSI ISUP the LRN portion of the Generic Address Parameter and the 'M' bit of the Forward Call Indicators, are used to route calls in the PSTN. Since these fields are rendered as tel URL parameters in the SIP-ISUP mapping, users can set the value of these fields arbitrarily. Consequently, an end-user could change the end office to which a call would be routed (though if LRN value were chosen at random, it is more likely that it would prevent the call from being delivered altogether). The PSTN is relatively resilient to calls that have been misrouted on account of local number portability, however. In some networks, a REL message with some sort of "misrouted ported number" cause code is sent in the backwards direction when such a condition arises. Alternatively, the PSTN switch to which a call was misrouted can forward the call along to the proper switch after making its own number portability query - this is an interim number portability practice that is still common in most segments of the PSTN that support portability. It is not anticipated that end users will typically set these SIP fields, and the risks associated with allowing an adventurous or malicious user to set the LRN do not seem to be grave, but they should be noted by network operators. The limited degree to which SIP signaling contributes to the interworking indicators of the Forward Call Indicators and Backward Call Indicator parameters incurs no foreseeable risks.

From "RFC3398"
(C) The Internet
Society

番号ポータビリティについては、本標準の範囲外である。

Some additional risks may result from the SIP response code to ISUP Cause Code parameter mapping. SIP user agents could conceivably respond to an INVITE from a gateway with any arbitrary SIP response code, and thus they can dictate (within the boundaries of the mappings supported by the gateway) the Q.850 cause code that will be sent by the gateway in the resulting REL message. Generally speaking, the manner in which a call is rejected is unlikely to provide any avenue for fraud or denial of service - to the best knowledge of the authors there is no cause code identified in this document that would signal that some call should not be billed, or that the network should take critical resources off-line. However, operators may want to scrutinize the set of cause codes that could be mapped from SIP response codes (listed in 7.2.6.1) to make sure that no undesirable network-specific behavior could result from operating a gateway supporting the recommended mappings. In some cases, operators MAY wish to implement gateway policies that use alternative mappings, perhaps selectively based on authorization data.

From "RFC3398"
(C) The Internet
Society

If the Request-URI and the To header field of a request received at a gateway differ, Section 7.2.1.1 recommends that the To header (if it is a telephone number) should map to the Original Called Number parameter, and the Request-URI to the Called Party Number parameter. However, the user can, at the outset of a request, select a To header field value that differs from the Request-URI; these two field values

From "RFC3398"
(C) The Internet
Society

are not required to be the same. This essentially allows a user to set the ISUP Original Called Number parameter arbitrarily. Any applications that rely on the Original Called Number for settlement purposes could be affected by this mapping recommendation. It is anticipated that future SIP work in this space will arrive at a better general account of the re-targeting of SIP requests that may be applicable to the OCN mapping.

From "RFC3398"
(C) The Internet
Society



To ヘッダのマッピングに関しては本標準の範囲外である。



The arbitrary population of the From header of requests by SIP user agents has some well-understood security implications for devices that rely on the From header as an accurate representation of the identity of the originator. Any gateway that intends to use the From header to populate the called party's number parameter of an ISUP IAM message should authenticate the originator of the request and make sure that they are authorized to assert that calling number (or make use of some more secure method to ascertain the identity of the caller). Note that gateways, like all other SIP user agents, MUST support Digest authentication as described in [1].

From "RFC3398"
(C) The Internet
Society



From ヘッダのマッピングに関しては本標準の範囲外である。ただし、何らかのマッピングを行う場合においては、上記の考慮が必要である。

There is another class of potential risk that is related to the cut-through of the backwards media path before the call is answered. Several practices described in this document recommend that a gateway signal an ACM when a called user agent returns a 18x provisional response code. At that time, backwards media will be cut through end-to-end in the ISUP network, and it is possible for the called user agent then to play arbitrary audio to the caller for an indefinite period of time before transmitting a final response (in the form of a 2xx or higher response code). There are conceivable respects in which this capability could be used illegitimately by the called user agent. It is also however a useful feature to allow progress tones and announcements to be played in the backwards direction in the 'ACM sent' state (so that the caller won't be billed for calls that don't actually complete but for which failure conditions must be rendered to the user as in-band audio). In fact, ISUP commonly uses this backwards cut-through capability in order to pass tones and announcements relating to the status of a call when an ISUP network interworks with legacy networks that are not capable of expressing Q.850 cause codes.

From "RFC3398"
(C) The Internet
Society



It is the contention of the authors that SIP introduces no risks with regard to backwards media that do not exist in Q.931-ISUP mapping, but gateways implementers MAY develop an optional mechanism (possibly something that could be configured by an operator) that would cut off such 'early media' on a brief timer - it is unlikely that more than 20 or 30 seconds of early media is necessary to convey status information about the call (see Section 7.2.6). A more conservative approach would be to never cut through backwards media in the gateway until a 2xx final response has been received, provided that the

From "RFC3398"
(C) The Internet
Society

gateway implements some way of prevent clipping of the initial media associated with the call.

From "RFC3398"
(C) The Internet
Society



5.2 節や 8.2.3 節に記述した通り、本仕様の範囲においては、MGC/MGを管理する事業者SIP網と同一もしくは応答前音源接続の合意のある事業者SIP網内において、第三者であるユーザ等が音源を操作できないことが保証されるノードからのメディアであることが判断可能である場合を除いて、2xxレスポンス受信前に逆方向パスを接続してはいけない。なお、逆方向パス接続に関するリスクに関しては、付録 i に記述する。

Unlike a traditional PSTN phone, a SIP user agent can launch multiple simultaneous requests in order to reach a particular resource. It would be trivial for a SIP user agent to launch 100 SIP requests at a 100 port gateway, thereby tying up all of its ports. A malicious user could choose to launch requests to telephone numbers that are known never to answer, which would saturate these resources indefinitely and potentially without incurring any charges. Gateways therefore MAY support policies that restrict the number of simultaneous requests originating from the same authenticated source, or similar mechanisms to address this possible denial-of-service attack.

16. IANA Considerations

This document introduces no new considerations for IANA.

17. Acknowledgments

This document existed as an Internet-Draft for four years, and it received innumerable contributions from members of the various Transport Area IETF working groups that it called home (which included the MMUSIC, SIP and SIPPING WGs). In particular, the authors would like to thank Olli Hynonen, Tomas Mecklin, Bill Kavasdas, Jonathan Rosenberg, Henning Schulzrinne, Takuya Sawada, Miguel A. Garcia, Igor Slepchin, Douglas C. Sicker, Sam Hoffpauir, Jean-Francois Mule, Christer Holmberg, Doug Hurtig, Tahir Gun, Jan Van Geel, Romel Khan, Mike Hammer, Mike Pierce, Roland Jesske, Moter Du, John Elwell, Steve Bellovin, Mark Watson, Denis Alexeitsev, Lars Tovander, Al Varney and William T. Marshall for their help and feedback on this document. The authors would also like to thank ITU-T SG11 for their advice on ISUP procedures.

18. Normative References

- [1] Rosenberg, J., Schulzrinne, H., Camarillo, G., Johnston, A., Peterson, J., Sparks, R., Handley, M. and E. Schooler, "SIP: Session Initiation Protocol", RFC 3261, June 2002.
- [2] Bradner, S., "Key words for use in RFCs to indicate requirement levels", BCP 14, RFC 2119, March 1997.
- [3] Zimmerer, E., Peterson, J., Vemuri, A., Ong, L., Audet, F., Watson, M. and M. Zonoun, "MIME media types for ISUP and QSIG objects", RFC 3204, December 2001.

- [4] Freed, N. and N. Borenstein, "Multipurpose Internet Mail Extensions (MIME) Part Two: Media Types", RFC 2046, November 1996.
- [5] Schulzrinne, H. and S. Petrack, "RTP Payload for DTMF Digits, Telephony Tones and Telephony Signals", RFC 2833, May 2000.
- [6] Donovan, S., "The SIP INFO Method", RFC 2976, October 2000.
- [7] Vaha-Sipila, A., "URLs for Telephone Calls", RFC 2806, April 2000.
- [8] Faltstrom, P., "E.164 number and DNS", RFC 2916, September 2000.
- [9] Schulzrinne, H., Camarillo, G. and D. Oran, "The Reason Header Field for the Session Initiation Protocol", RFC 3326, December 2002.
- [9A] Vemuri, A. and J. Peterson, "Session Initiation Protocol for Telephones (SIP-T): Context and Architectures", BCP 63, RFC 3372, September 2002.
- [9B] Peterson, J., "A Privacy Mechanism for the Session Initiation Protocol (SIP)", RFC 3323, November 2002.

19. Non-Normative References

- [10] International Telecommunications Union, "Application of the ISDN user part of CCITT Signaling System No. 7 for international ISDN interconnection", ITU-T Q.767, February 1991, <<http://www.itu.int>>.
- [11] American National Standards Institute, "Signaling System No. 7; ISDN User Part", ANSI T1.113, January 1995, <<http://www.itu.int>>.
- [12] International Telecommunications Union, "Signaling System No. 7; ISDN User Part Signaling procedures", ITU-T Q.764, December 1999, <<http://www.itu.int>>.
- [13] International Telecommunications Union, "Abnormal conditions - Special release", ITU-T Q.118, September 1997, <<http://www.itu.int>>.
- [14] International Telecommunications Union, "Specifications of Signaling System No. 7 - ISDN supplementary services", ITU-T Q.737, June 1997, <<http://www.itu.int>>.

- [15] International Telecommunications Union, "Usage of cause location in the Digital Subscriber Signaling System No. 1 and the Signaling System No. 7 ISDN User Part", ITU-T Q.850, May 1998, <<http://www.itu.int>>.
- [16] International Telecommunications Union, "The international public telecommunications numbering plan", ITU-T E.164, May 1997, <<http://www.itu.int>>.
- [17] International Telecommunications Union, "Formats and codes of the ISDN User Part of Signaling System No. 7", ITU-T Q.763, December 1999, <<http://www.itu.int>>.
- [18] Rosenberg, J. and H. Schulzrinne, "Reliability of Provisional Responses in SIP", RFC 3262, June 2002.
- [19] Stewart, R., "Stream Control Transmission Protocol", RFC 2960, October 2000.
- [20] Rosenberg, J., "The Session Initiation Protocol (SIP) UPDATE Method", RFC 3311, October 2002.
- [21] Yu, J., "Extensions to the 'tel' and 'fax' URL in support of Number Portability and Freephone Service", Work in Progress.

Authors' Addresses

Gonzalo Camarillo
Ericsson
Advanced Signalling Research Lab.
FIN-02420 Jorvas
Finland

Phone: +358 9 299 3371
URI: <http://www.ericsson.com/>
EMail: Gonzalo.Camarillo@Ericsson.com

Adam Roach
dynamicsoft
5100 Tennyson Parkway
Suite 1200
Plano, TX 75024
USA

URI: <sip:adam@dynamicsoft.com>
EMail: adam@dynamicsoft.com

Jon Peterson
NeuStar, Inc.
1800 Sutter St
Suite 570
Concord, CA 94520
USA

Phone: +1 925/363-8720
EMail: jon.peterson@neustar.biz
URI: <http://www.neustar.biz/>

Lyndon Ong
Ciena
10480 Ridgeview Court
Cupertino, CA 95014
USA

URI: <http://www.ciena.com/>
EMail: lyOng@ciena.com

Full Copyright Statement

Copyright (C) The Internet Society (2002). All Rights Reserved.

This document and translations of it may be copied and furnished to others, and derivative works that comment on or otherwise explain it or assist in its implementation may be prepared, copied, published and distributed, in whole or in part, without restriction of any kind, provided that the above copyright notice and this paragraph are included on all such copies and derivative works. However, this document itself may not be modified in any way, such as by removing the copyright notice or references to the Internet Society or other Internet organizations, except as needed for the purpose of developing Internet standards in which case the procedures for copyrights defined in the Internet Standards process must be followed, or as required to translate it into languages other than English.

The limited permissions granted above are perpetual and will not be revoked by the Internet Society or its successors or assigns.

This document and the information contained herein is provided on an "AS IS" basis and THE INTERNET SOCIETY AND THE INTERNET ENGINEERING TASK FORCE DISCLAIMS ALL WARRANTIES, EXPRESS OR IMPLIED, INCLUDING BUT NOT LIMITED TO ANY WARRANTY THAT THE USE OF THE INFORMATION HEREIN WILL NOT INFRINGE ANY RIGHTS OR ANY IMPLIED WARRANTIES OF MERCHANTABILITY OR FITNESS FOR A PARTICULAR PURPOSE.

Acknowledgement

Funding for the RFC Editor function is currently provided by the Internet Society.

付属資料 a. ISUP メッセージ設定値

本付属資料は、SIP から ISUP へのインタワーク時における ISUP メッセージ内のパラメータ値として、ISDN アクセス表示に「非 ISDN アクセス」を適用した場合の生成条件の一部について規定したものである。

a.1. アドレスメッセージ(IAM)

付表 a-1/JF-IETF-RFC3398 アドレスメッセージ(IAM)

パラメータ	要素	TTC 規定値	内容	デフォルト値(MGCでの生成条件)
接続特性表示	衛星回線表示	00 01 10 11	接続において衛星回線なし 接続において衛星回線 1 回線あり 接続において衛星回線 2 回線あり 予備	"00", "01", "10"から値を設定。衛星回線の使用状況が不明の場合は"00"を設定。
	導通試験表示	00 01 10 11	導通試験不要 導通試験必要 前位で導通試験実施 予備	"00"を設定。"10"の適用は今後の検討課題。
	エコー制御装置表示	0 1	出回線ハーフエコー制御装置挿入せず 出回線ハーフエコー制御装置挿入	"0", "1"の一方を設定。
順方向呼表示	国内/国際呼表示	0 1	国内呼として処理される呼 国際呼として処理される呼	"0"を設定。"1"の適用(国際呼)は将来における検討事項。
	エンド・エンド法表示	00	エンド・エンド法が利用できない	"00"を設定。
	相互接続表示	0 1	相互接続なし 相互接続あり	"0"を設定。
	エンド・エンド情報表示	0	エンド・エンド情報利用できない	"0"を設定。
	ISUP1 リンク表示	0 1	ISUP1 リンクでない ISUP1 リンクである	"1"を設定。
	ISUP1 リンク希望表示	00 01 10 11	ISUP1 リンクを希望するが必須ではない ISUP1 リンクを希望しない ISUP1 リンクを希望し必須である 予備	"00", "10"のいずれかを設定。
	ISDN アクセス表示	0 1	発側のユーザ・網インタフェースが非 ISDN 発側のユーザ・網インタフェースが ISDN	"0"を設定。
	SCCP 法表示	00	表示なし	"00"を設定。
発ユーザ種別		00001001 00001010 00001011 00001101 00001110 00001111	国内台 一般発ユーザ 優先発ユーザ 試験呼 予備 公衆電話	"00001001", "00001010", "00001011", "00001101", "00001111"から適切な値を設定。判断不可能な場合は"00001010"を設定。
通信路要求表示		00000000 00000001 00000010 00000011 00000100 00000101 00001000 00001001	音声 予備 64kbit/s 非制限 3.1kHz オーディオ 音声/64kbit/s 非制限切替用に留保 64kbit/s 非制限/音声切替用に留保 384kbit/s 非制限 1536kbit/s 非制限	"00000011"を設定。

a.2. アドレス完了メッセージ(ACM), 応答メッセージ(ANM)

付表 a-2/JF-IETF-RFC3398 アドレス完了メッセージ(ACM), 応答メッセージ(ANM)

パラメータ	要素	TTC 規定値	内容	デフォルト値(MGCでの生成条件)
逆方向呼表示	課金表示	00	表示なし	本付属資料では課金条件までは言及しないが、呼毎に適切なインタワークが必要。
		01	非課金	
		10	課金	
		11	予備	
	着ユーザ状態表示	00	表示なし	標準本文(8.2.3節)の規定に従う
		01	加入者空	
		10	空き時接続	
		11	予備	
	着ユーザ種別表示	00	表示なし	"00", "01", "10"から適切な値を設定。判断不可能な場合は"01"を設定。
		01	一般ユーザ	
		10	公衆電話	
		11	予備	
エンド・エンド法表示		00	エンド・エンド法が利用できない	"00"を設定。
相互接続表示		0	相互接続なし	"0"を設定。
		1	相互接続あり	
エンド・エンド情報表示		0	エンド・エンド情報利用できない	"0"を設定。
ISUP1リンク表示		0	ISUP1リンクでない	"1"を設定。
		1	ISUP1リンクである	
保留表示		0	保留必要なし	"0"を設定。
ISDN アクセス表示		0	着側のユーザ・網インタフェースが非ISDN	"0"を設定。
		1	着側のユーザ・網インタフェースがISDN	
エコー制御装置表示		0	入回線エコー制御装置挿入なし	"0", "1"の一方を設定。
		1	入回線エコー制御装置挿入済	
SCCP 法表示		00	表示なし	"00"を設定。

付属資料 b. ISDN アクセス表示 (ISDN/非 ISDN) に関する留意点

b.1. 本付属資料の目的

IP 電話端末を中心に、今後のユーザ端末は、従来のような「ISDN」/「非 ISDN」といった区分けは困難になると想定されるが、JJ-90.10 を利用した相互接続を行う場合、「ISDN」もしくは「非 ISDN」のいずれかを明示する信号設定(順方向呼情報パラメータ)が必須となる。本付属資料では、ISDN アクセス表示の種別によってインタワークを行う MGC が ISUP 信号処理上留意する必要がある事項について記述する。

b.2. パラメータ設定に関する留意事項

b.2.1. 非 ISDN を明示する場合

非 ISDN ユーザ発信の場合は、アドレスメッセージ(IAM にユーザ・ユーザ情報、ユーザ・ユーザ表示、アクセス転送の各パラメータは設定しない。また、非 ISDN ユーザ着信においても、返送するアドレス完了メッセージ(ACM)にユーザ・ユーザ情報は設定しないなど、ISDN 特有に用いられるパラメータは設定しないこと。

b.2.2. ユーザ・ユーザ情報要求への対応

IAM におけるユーザ・ユーザ情報のマッピングにより、ユーザ・ユーザサービスの利用を要求した場合であっても、JJ-90.10 もしくは事業者間の協定等に基づいた手順により、廃棄通知を行うこと。

廃棄処理が正常に行われない場合、発信ユーザに対して送達されていないユーザ・ユーザ情報を課金する(すなわち誤課金)などの問題が生じる恐れがある。

b.2.3. ISDN 固有サービスへの対応

IAM の通信路要求表示にて「64Kbit/s 非制限」が要求された場合や、アクセス転送/ユーザ・サービス情報により DSS1 固有の情報に基づき、呼接続を要求した場合であっても、適切な理由表示に基づいた切断や、非 ISDN と同等のサービスレベルに基づいた応答等の対応を行うこと。

「非 ISDN」に対して「64Kbit/s 非制限」を設定することは、本来想定しがたく、本パラメータの組み合わせを受信した場合は、呼損となる等の問題も想定される。

付録 i ISUP 発 SIP 着における逆方向パス接続に関する留意点について

SIPからの呼完了前の音声パス接続については以下のフローのように SIP-PSTN-SIP で不正にリソースを消費される可能性もある。(下記参考図は極端な例であるが、着端末から音声パスが応答前に PSTN を通して接続されることが一般的には問題となる可能性がある)

したがって、SIP 側からの音声パスの接続を行う場合には、対応する SIP 端末が網内のアナウンスサーバである場合や対向する MGC の場合等、その要求の正当性を確認できる場合にのみ音声パスを接続する等の対応が必要となる。

付図 b/JF-IETF-RFC3398 参考図

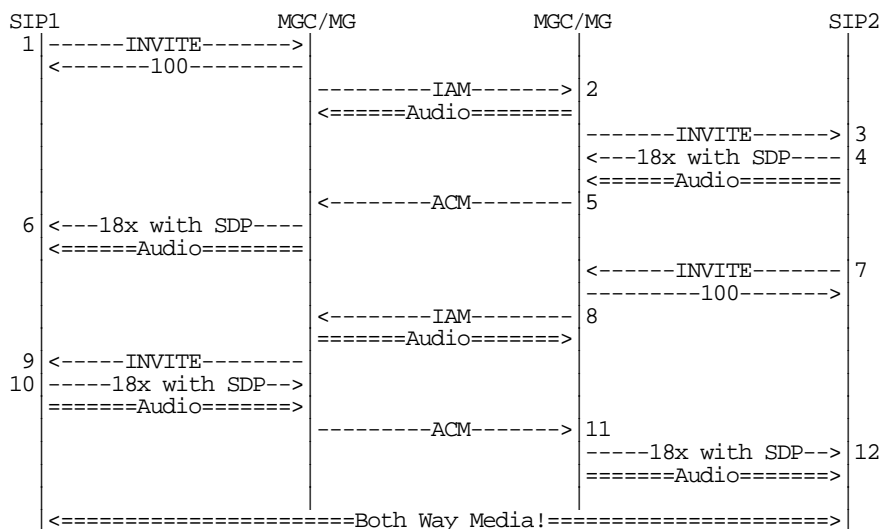

なお、事業者 SIP 網をまたがる場合の正当性の確認（すなわち第三者であるユーザ等が事業者が意図しない音源を接続しないことを保証することおよび、発側ユーザが接続状態を把握できることを保証すること）の方式については、技術的な根拠と整合性が確保される方式で、相互接続する事業者間での合意の上、関連する事業者が責任を持って実現するものとし、本標準の範囲では、具体的な方式については限定しない。

付録 ii JF-IETF-RFC3398 と ITU-T 勧告 Q.1912.5 との差分について

本付録では、SIP と ISUP のインタワークに関して IETF の RFC3398[2] をベースとして制定された JF-IETF-RFC3398 と、2004 年 3 月に ITU-T において勧告化がなされた Q.1912.5[13] との差分内容について記述する。

下記の付表 ii - 1 ～ 6 において、太字斜体部分が両技術仕様の差分を表す。

付表 ii - 1 / JF-IETF-RFC3398 JF-IETF-RFC3398 と ITU-T 勧告 Q.1912.5 との差分について

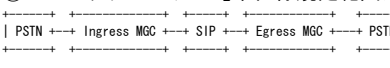
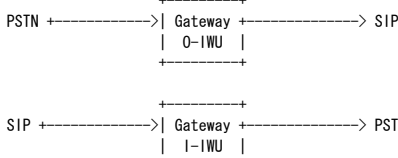
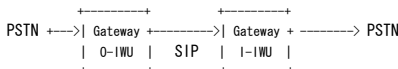
項番	項目	JF-IETF-RFC3398	ITU-T 勧告(Q.1912.5)	差分内容
1	概要	<p>【概要】<1 章参照> 2 つの信号プロトコル(SIP、ISUP)間のマッピングを行う方法を記述している。このメカニズムは公衆交換電話網(PSTN)と相互接続が必要な環境で SIP を使う時に実装されるかもしれない。</p> <p>【ネットワークモデル】<4 章参照> ①PSTN 網-SIP 網モデル  ②SIP ブリッジモデル【本仕様規定範囲外】 </p>	<p>【概要】<Summary 参照> BICC、ISUP に一般にサポートすることができるサービスおよび SIP 網のネットワーク領域をサポートするために BICC、ISUP のプロトコルと SIP の間の信号方式インタワーキングを定義。</p> <p>【ネットワークモデル】<1 章参照> ①Profile A (SIP 3GPP モバイル網-PSTN 網) Profile B (SIP 網-PSTN 網)  ②Profile C (SIP-I) </p>	<ul style="list-style-type: none"> ・BICC について JF-IETF-RFC3398 では、仕様規定範囲外。 ・ネットワークモデル Profile A について JF-IETF-RFC3398 では記述なし。 Profile C(SIP ブリッジ)について JF-IETF-RFC3398 では仕様規定範囲外。
2	範囲	<p>①SIP-ISUP のインタワーキング<2 章参照> ②ISUP メッセージの SIP メッセージへのマッピングと、ISUP パラメータの SIP ヘッダへのマッピングを定義。 ③SIP ヘッダから ISUP パラメータへのマッピングは、IAM のパラメータと INVITE メッセージに関連するヘッダ間のマッピングが焦点。</p>	<p>①SIP-ISUP 及び SIP-BICC のインタワーキング<1 章参照> ②BICC または ISUP と SIP 間でのシグナリングインタワークを定義。 UNI での SIP インタワーキングのサポートは、この勧告の範囲以外。 ③SIP ネットワークで分岐しているインタワーキングは明確にされておらず、先々の検討。</p>	<ul style="list-style-type: none"> ・SIP-BICC について JF-IETF-RFC3398 の仕様規定範囲外。 これ以降、BICC 記述に閉じた内容の詳細比較は省略。
3	ISUP カプセル化	<p>(1)カプセル化の方法<5.1 章参照> 【本仕様規定範囲外】 ※RFC3398 上では記述有り。 SIP ブリッジの場合、ISUP メッセージは SIP メッセージにカプセル化する。ISUP カプセル化の詳細な内容は RFC3204 に記載。</p>	<p>(1)カプセル化の方法<5.4 章参照> ①SIP メッセージを受信する IWU (I-IWU) は、SIP メッセージから(カプセル化した)ISUP メッセージを取り除く。 ②ISUP メッセージを受信する IWU (O-IWU) は、SIP メッセージのボディ部に ISUP メッセージをカプセル化する。</p>	<ul style="list-style-type: none"> ・カプセル化について JF-IETF-RFC3398 では、仕様規定範囲外。
4	ISUPMIME ボディのためのヘッダフィールド	<p>(1)ISUP MIME ボディ設定ヘッダ<5.2 章参照> 【本仕様規定範囲外】 ※RFC3398 上では記述有り。 “Accept”ヘッダに multipart/mixed を含めることで実現。</p>	<p>(1)ISUP MIME ボディ設定ヘッダ<5.4.1.2 章参照> ①Content-Type の設定 Content-Type: application/ISUP; version= itu-t92+; (itu-t92 : ISUP92 プラス、後全ての ISUP バージョン) ②Content-Disposition の設定 Content-Disposition: signal; handling = required.</p>	<ul style="list-style-type: none"> ・JF-IETF-RFC3398 では、仕様規定範囲外。
5	INVITE 受信のイン	<p>(1)インタワーク方法<7.2.1.1 章, 12 章参照> INVITE の SIP ヘッダと IAM の ISUP パラメータ</p>	<p>(1)インタワーク方法<6.1.3 章参照> INVITE の SIP ヘッダと IAM の ISUP パラメータ</p>	<ul style="list-style-type: none"> ・userinfo について Q.1912.5 では、<sip:電話

項番	項目	JF-IETF-RFC3398	ITU-T 勧告(Q.1912.5)	差分内容
	ネットワーク	<p>をインタワーク。 (2)IAM の ISUP パラメータ INVITE の SIP ヘッダから IAM の ISUP パラメータを生成。</p> <p>①必須パラメータ(M)</p> <ul style="list-style-type: none"> ・CPN ・CPC ・NCI ・FCI ・TMR <p>②オプションパラメータ(O)</p> <ul style="list-style-type: none"> ・USI 本仕様上は、オプション。 ※RFC3398 上では記述有り。 TMR と USI のどちらか片方 or 両方が必須である。 ・OCN 本仕様上、To ヘッダのマッピングは仕様範囲外と記述有り。 ※RFC3398 上では記述有り。 To と Request-URI が不一致の場合、To を OCN に、Request-URI を着番号へマッピングすることを推奨する。 ・TNS ・CIP ・汎用ディジット ※JF-IETF-RFC3398 では汎用ディジット (Generic Digits)は、使用されない。 <p>(3)番号通知のパラメータ <5.7 章、12 章参照> JJ-90.22 の記述に従う。</p> <p>(4)番号ポータビリティの実現 【本仕様規定範囲外】 ※RFC3398 上では記述有り。</p> <ul style="list-style-type: none"> ・"npdi=yes"記述により番号ポータビリティを試みる。 ・"rn="フィールドの後に番号ポータビリティ後の ISUP 番号を記述する。(無ければ、番号ポータビリティは行なわれない) ・ANSI ベースの ISUP "rn="フィールドの番号を CPN パラメータに設定できるような手順で、ISUP フォーマットへと変換し、設定する。 <p>(5)SDP オファーを含まない場合 記述なし。</p>	<p>タをインタワーク。 (2)IAM の ISUP パラメータ INVITE の SIP ヘッダから IAM の ISUP パラメータを生成。</p> <p>①必須パラメータ(M)</p> <ul style="list-style-type: none"> ・CPN userinfo (user=phone の値が存在する場合のみ規定) ・CPN 内 (Address Signaling 部) ・TMR(SDP より設定値を決定) インタワーク元なし。 ・CPC, NCI, FCI ※以上、生成デフォルト値について記述有り。 <p>②オプションパラメータ(O)</p> <ul style="list-style-type: none"> ・USI, Generic Number, HLC, ATP, Hop Counter ※USI, Generic Number, HLC Hop Counter の設定値について記述あり。 <p>(3)番号通知のパラメータ 具体的なマッピングに関する表 (Table 7-10) に記述あり。(RFC3323・3325 を使用)</p> <p>(4)番号ポータビリティの実現 記述無し。</p> <p>(5)SDP オファーを含まない場合 信頼ある暫定応答がサポートされる場合、I-IWU は、ローカルポリシーから決定されたメディア記述を含む SDP オファーを 183 Session Progress に含み、直ちに送信する。 上記動作において、I-IWU が国際ゲートウェイかつ G.711 が使用される場合</p> <ul style="list-style-type: none"> ・A-law PSTN との接続なら、SDP に A-law の記述をのせる。 ・μ-law PSTN との接続なら、SDP に μ-law と A-law の記述をのせる。 (μ-law が優先) 	<p>番号@domain;user=phone>を持つ場合のみを規定。 JF-IETF-RFC3398 では、<tel:電話番号>、<sip:電話番号@domain>を規定。 ・オプションパラメータの記述について Q.1912.5 では、Generic Number、HLC、ATP、Hop Counter のみ記述があり、JF-IETF-RFC3398 では、TNS、CIP のみ記述がある。 また、TMR と USI に関して、Q.1912.5 では、設定値についての具体的な記述があるが、JF-IETF-RFC3398 には記述がない。 ・番号通知パラメータについて JF-IETF-RFC3398 では、JJ-90.22 の記述に従う。 ・SDP オファーが含まれていない場合についての記述の有無。</p>
6	CANCEL もしくは BYE 受信 のインタ ワーク	<p>(1)インタワーク方法<7.2.3 章参照> 最終レスポンス前に、BYE か CANCEL を受信した際に、SIP 網に確認応答の 200OK と INVITE 処理を終了する為の 487 Request terminated を送信する。 すべてのリソースを開放し、cause code 16 付きの REL メッセージを PSTN に送る。 CANCEL か BYE に Reason ヘッダが含まれる場合、Cause Indicator parameter にマッピングされるべきである。 ゲートウェイのすべての資源は、ゲートウェイが REL メッセージを送る前に開放されるべきである。</p> <p>①SIPブリッジである場合 【本仕様規定範囲外】 ※RFC3398 上では記述有り。</p> <ul style="list-style-type: none"> ・REL が BYE のボディにカプセル化される可能性があり、その場合、カプセル化された REL を優先して送信すべきである。 例外的に REL 内の Cause Value が異なる場合は、カプセル化された REL を優先すべきである。 	<p>(1)インタワーク方法<5.4.3.4 章、6.11.1 章参照> BYE か CANCEL を受信した際に、ISUP 側に REL を送信する。 BYE か CANCEL に Q.850 Cause Value を含む Reason ヘッダが含まれている場合、Cause Value は、local policy に依存する ISUP REL の中の ISUP Cause Value へマッピングされるかもしれない。 Reason ヘッダが含まれていなければ、BYE が cause code 16、CANCEL が cause code 31 にマッピングされる。</p> <p>①SIPブリッジである場合</p> <ul style="list-style-type: none"> ・BYE メッセージに含まれるカプセル化された REL メッセージを取り出し、PSTN 網に送信する。 また、SIP 側には、200 OK レスポンスに BICC/ISUP 手順によって生成された RLC をカプセル化する。 	<p>・CANCEL 処理による 487 の送信に関する記述の有無。 ・CANCEL 受信時の REL cause code 設定値について、Q.1912.5 では 31、JF-IETF-RFC3398 では 16 を使用。 ・SIPブリッジについて JF-IETF-RFC3398 では、仕様規定範囲外。</p>
7	REL 受信 のインタ ワーク	<p>(1)インタワーク方法 <7.2.4 章参照> ・SIP 網からのリクエストが PSTN によって拒絶された時に生じる。</p>	<p>(1)インタワーク方法 <6.11.2 章参照> ・ISUP 回線が再利用可能である場合、I-IWU から、ISUP 側に RLC が返され、SIP 側には</p>	<p>・Cause Value へのマッピングについて、付表 2 に記述される。</p>

項番	項目	JF-IETF-RFC3398	ITU-T 勧告(Q.1912.5)	差分内容
	(SIP 側発信時)	<p>・最終レスポンス前に REL を受信した場合、回線の再利用が可能なことを示すために ISUP ネットワークにRLCを送らなくてはならない。</p> <p>・マッピングに関しては、付表2を参照。</p> <p>リクエスト先が欠番であった場合、理由表示値 #1 のRELのマッピングについては、SIP側で欠番を示すレスポンスにマッピングする。事業者SIP網間の接続インタフェース(インタフェースA)により、Reason ヘッダ(Q.850;cause=1) [11]を付加した404レスポンスへのマッピングが推奨される。</p> <p>付表2に該当しないCause Value のものは500 Internal Server Error にマッピングされる。</p> <p>・SIP 網に対して、もしカプセル化したISUPを解しないのなら、ゲートウェイはカプセル化したISUP レスポンスを返すべきではない。【本仕様規定範囲外】</p>	<p>適切な SIP ステータスコードを送る。(最終応答または、BYE)</p> <p>・BICC/ISUP Cause Value から SIP ステータスコードへのマッピングに関しては BICC/ISUP Cause Value は適切な Q.850 クラス・デフォルトと同じマッピングを持つ。Reason ヘッダが利用可能で無い場合、付表2を参照。</p> <p>・ANM や CON を受け取る前に、REL を受信した場合、適切な SIP ステータスコードの最終応答を送信する。</p> <p>・BICC/ISUP Cause Value から SIP ステータスコードへのマッピングに関しては付表2を参照。</p> <p>・Reason ヘッダが付表2に該当しない場合、Q.850 クラス・デフォルトと同じマッピングを用いるべき。</p>	
8	Early ACM 受信のインタワーク	<p>(1)インタワーク方法<7.2.5 章参照></p> <p>・Early ACMを受信したゲートウェイは、SIPネットワークに183 Session Progress を送るべきである。</p> <p>・SIPブリッジである場合【本仕様規定範囲外】</p> <p>※RFC3398 上では記述有り。</p> <p>183レスポンスにEarly ACM がカプセル化されるべきである。</p>	<p>(1)インタワーク方法</p> <p>・記述無し。</p>	・記述の有無について。
9	ACM 受信のインタワーク	<p>(1)インタワーク方法<7.2.6 章参照></p> <p>ACM を受信した場合、暫定応答メッセージ(18x)がSIPネットワークに送られるべきである。もし、セッションを始めたINVITE が正しく理解可能なカプセル化 ISUP を含むなら、GW は受信した ACM を暫定応答にカプセル化すべきである。</p> <p>①BCI が“subscriber free”の場合 ACM → 180 Ringing (INVITE が理解可能なカプセル化 ISUP を含むなら、ACM がカプセル化すべき。ただし、カプセル化は本仕様規定範囲外。)</p> <p>②BCI が“no indication” または “subscriber-free” 以外の値である場合</p> <p>記述無し。</p> <p>※但し、no indication となっていた場合は、Early ACM とみなす。</p> <p>SIPブリッジの場合【本仕様規定範囲外】</p> <p>ACM → 183 Session Progress (ACM をカプセル化する。)</p> <p>③BCI の“Interworking Indicator”が1の場合</p> <p>ACM の BCI パラメータがインタワークありを示す場合、逆方向メディア伝送が始められるべきである。</p> <p>④Early メディア転送に関して</p> <p>Early メディア転送が始められた後、GW は 183 Session Progress を送るべきである。</p> <p>⑤タイムについて【本仕様規定範囲外】</p> <p>ACM を受信すると多くの ISUP ネットワークの交換機は、T9 タイマを起動し、これは通常 90 秒から 3 分で切れる。</p> <p>※本仕様では T9 タイマは適用されない。</p>	<p>(1)インタワーク方法<6.5 章参照></p> <p>ACM を受信した場合、Called Party's status Indicator の BCI の値によって、SIPレスポンスが決定され、送信される。</p> <p>①BCI が“subscriber free”の場合</p> <p>・SIPブリッジでない場合</p> <p>ACM → 180 Ringing</p> <p>・SIPブリッジの場合</p> <p>ACM → 180 Ringing (ACM をカプセル化する)</p> <p>②BCI が“no indication” または “subscriber-free” 以外の値である場合</p> <p>・SIPブリッジでない場合</p> <p>ACM はインタワークされない</p> <p>・SIPブリッジの場合</p> <p>ACM → 183 Session Progress (ACM をカプセル化する)</p> <p>③BCI の“Interworking Indicator”が1の場合</p> <p>記述無し。</p> <p>④Early メディア転送に関して</p> <p>記述無し。</p> <p>⑤タイムについて</p> <p>呼のタイムは T9 か、他のタイムが使用される。</p>	<p>・BCI パラメータ使用について、Interworking Indicator に1が設定されている場合の動作記述の有無。</p> <p>・Early メディア転送についての記述の有無。</p> <p>・T9 タイマの使用について、JF-IETF-RFC3398 では仕様規定範囲外。</p>
10	ANM 受信のインタワーク	<p>(1)インタワーク方法<7.2.7 章参照></p> <p>ANM を受信した場合、200 OK 応答が SIP ネットワークに送信される。</p> <p>①SIPブリッジの場合【本仕様規定範囲外】</p>	<p>(1)インタワーク方法<6.7 章参照></p> <p>BICC/ISUP ANM を受信した場合は、UAC に INVITE に対する 200OK を送信する。</p> <p>①SIPブリッジの場合</p>	・インタワーク時のメディアについて <p>Q.1912.5 では、Initial INVITE に SDP オファーが</p>

項番	項目	JF-IETF-RFC3398	ITU-T 勧告(Q.1912.5)	差分内容
		<p>※RFC3398 上では記述有り。 SIPブリッジ状態で(INVITEが正しく理解可能なカプセル化 ISUPを含む場合)、ISUPメッセージは200 OKのボディ部に含まれる。</p> <p>②インタワーク時のメディアについて 200 OK 応答には INVITE で提案したメディアの応答を含むべきである。</p>	<p>SIPブリッジが適用可能な場合、ANMは、INVITE最終レスポンス(200 OK)にカプセル化される。</p> <p>②インタワーク時のメディアについて I-WUは、Initial INVITEにSDPオファーが含まれていない場合、INVITEに対する200OKにSDPオファーを含むだろう。</p>	<p>含まれていない場合が記述され、JF-IETF-RFC3398では、200OKでINVITEからのメディアの応答(SDPアンサー)を含むべきであると記述。</p> <p>・JF-IETF-RFC3398において、SIPブリッジは、仕様規定範囲外。</p>
11	CPG受信のインタワーク	<p>(1)インタワーク方法<7.2.9章参照> ・CPGは呼経過や呼出やインバンド情報を示す暫定的なメッセージである。もし、CPGがインバンド情報が利用可能であることを提案する場合、ゲートウェイはEarlyメディアの転送をはじめ、逆方向メディアパスを通し始めるべきである。</p> <p>※JF-IETF-RFC3398では、ACM受信前にインチャネル情報利用可能を示すCPGを受信する可能性がある。その場合、付加サービス等の利用を可能とするため、順方向のパスを接続するべき。なお、パス接続に関しては各事業者マター。との記述あり。</p> <p>①SIPブリッジでない場合 インタワークについて、特に記述無し。</p> <p>②SIPブリッジである場合【本仕様規定範囲外】 ※RFC3398上では記述有り。 セッションを始めたINVITEが正しく理解可能なカプセル化 ISUPを含んでいた時)ならば、ISUP event codeにより、以下の暫定応答メッセージ(18x)にカプセル化される。</p> <p>1 Alerting → 180 Ringing 2 Progress 3 In-band information - (イベントコードがない場合) 2,3,- → 183 Session progress 4 Call forward; line busy 5 Call forward; no reply 6 Call forward; unconditional 4,5,6 → 181 Call is being forwarded</p>	<p>(1)インタワーク方法<6.6章参照> ①SIPブリッジでない場合 a. Alerting → 180 Ringing b. Progress c. In-band information b.c → インタワーク無し。</p> <p>②SIPブリッジである場合 送られてきたCPGメッセージをカプセル化して、以下のインタワークされるSIPメッセージを含む。</p> <p>a. Alerting → 180 Ringing b. Progress c. In-band information b.c → 183 Session progress ※その他について記述無し。</p>	<p>・インタワーク方法の記述の有無。</p> <p>・JF-IETF-RFC3398において、SIPブリッジは、仕様規定範囲外。</p>
12	ACK受信のインタワーク	<p>(1)インタワーク方法<7.3章参照> この段階において呼は完全に接続され、会話が可能。ACK受信時にゲートウェイはISUPメッセージを送るべきではない。</p>	<p>(1)インタワーク方法 記述無し。</p>	<p>・インタワーク方法の記述の有無。</p>
13	IAM受信のインタワーク	<p>(1)インタワーク方法<8.2.1.1章,11.3章,12章参照> CPN ⇒ Request-URI (ENUMのクエリ検索を用いる可能性あり)、To CIN ⇒ ※番号通知パラメータに関しては、JJ-90.22に規定される。 OCN ⇒ (このパラメータが存在する場合、優先的に)To ※普段はCPNからToを生成。 他の手段として、GWが最初にCPNをURLにマッピングする為、電話番号マッピング(ENUM)問合せを試みるかもしれない。ある追加のISUPフィールドがマッピング完了後にtel-URLに加えられるかもしれない。</p> <p>①NCIパラメータの"Continuity Check Indicator"パラメータが設定されたIAMを受信した場合 ・ゲートウェイはINVITE送信前に接続検査を処理しなくてはならない。(その後、INVITEを送信する。)もし、接続検査に失敗した場合(Continuity Indicatorsが'failed'となっているGOTを受信した場合)→INVITEを送ってはいけない。 ※本仕様では、導通試験はサポートされない。</p>	<p>(1)インタワーク方法<7.1章参照> CPN ⇒ Request-URI、To CIN ⇒ P-Asserted-Identity、Privacy、From Generic Number ⇒ From<7.1.3章 Table 27-31参照> Hop Counter ⇒ Max-Forwards TMR/USI ⇒ Message Body ISUP Message ⇒ Message Body</p> <p>①NCIパラメータの"Continuity Check Indicator"パラメータが設定されたIAMを受信した場合 ・NCIパラメータで接続試験不要となっていた場合 → INVITEが送信される。 ・接続試験を要求され、試験に成功した場合 → INVITEが送信される。 ・接続試験に失敗した場合 → INVITEは送信されない。</p> <p>②番号ポータビリティについて 記述無し。</p>	<p>・パラメータの使用について、Q.1912.5では、Hop Counter,TMR/USI、ISUPメッセージ、JF-IETF-RFC3398ではOCNについて規定される。</p> <p>・導通試験のサポートについて、JF-IETF-RFC3398ではサポートされない。</p>

項番	項目	JF-IETF-RFC3398	ITU-T 勧告(Q.1912.5)	差分内容
		<p>②番号ポータビリティについて 【本仕様規定範囲外】 ※RFC3398 上では記述有り。 もし、GW が番号ポータビリティベースのルーティングをサポートする場合、FCI (number translated) ビットをマッピングするために、tel-URL に 'npdi=yes' フィールドが追加されるべきである。 また、もし IAM に GAP がある場合、CPN の内容が ISUP フォーマットからマッピングされるべきで、'rn=' フィールドにコピーし URL に追加し、GAP 自身は ISUP フォーマットにマッピングされ、tel-URL の主電話番号フィールドに代入するために使用される。</p>		
14	100 受信のインタワーク	<p>(1)インタワーク方法<8.2.2 章参照> 100 レスポンスはINVITE再送を停止させる意図のメッセージの為、PSTNへのインタワークは行うべきではない。</p>	(1)インタワーク方法 記述無し。	・インタワーク方法の記述の有無。
15	18x 受信のインタワーク	<p>(1)インタワーク方法<8.2.3 章参照> ①受信した 18x のボディに理解可能な ISUP 情報が存在しない場合 ・ACM 未送信の場合 181 Call is being forwarded ⇒ Early ACM and CPG, event=6 182 Queued ⇒ ACM (BCI = no indication) 183 Session progress ⇒ ACM (BCI = no indication) ・ACM が送信済みの場合 180 Ringing ⇒ CPG, event = 1 (Alerting) 181 Call is being forwarded ⇒ CPG, event = 6 (Forwarding) 182 Queued ⇒ CPG, event = 2 (Progress) 183 Session progress ⇒ CPG, event = 2 (Progress) ②受信した 18x のボディに理解可能な ISUP 情報が存在する場合 【本仕様規定範囲外】 ③カプセル化 ACM が存在しない場合の ACM に設定される BCI の値について ※18x レスポンスについての記述 Charge indicator: ⇒ 10 charge Called party's status indicator: ⇒01subscriber free or 00 no indication Called party's category indicator: ⇒01 ordinary subscriber End-to-end method indicator: ⇒00 no end-to-end method Interworking indicator: ⇒0 no interworking End-to-end information indicator: ⇒0 no end-to-end info ISDN user part indicator: ⇒1 ISUP used all the way Holding indicator: ⇒0 no holding ISDN access indicator:⇒0 No ISDN access Echo control device indicator: ⇒It depends on the call SCCP method indicator:⇒00 no indication</p>	<p>(1)インタワーク方法<7.3 章参照> ①受信した 18x のボディに理解可能な ISUP 情報が存在しない場合 180 Ringing ⇒ACM (BCI =subscriber free) か CPG, event = 1(Alerting)のいずれかを送信する。(ACM の送信の有無により決定) 183 Session Progress ⇒インタワークしない。 ※その他については記述無し。 ②受信した 18x のボディに理解可能な ISUP 情報が存在する場合 180 Ringing 183 Session progress ⇒上記2つとも、カプセル化された ISUP メッセージに基づいてインタワークされる。 ※その他については記述無し。 ※上記のインタワークが起こる場合において、ISUP メッセージを受信したとき、タイム起動中の場合はタイム「TOIW2」が止まる。 ③カプセル化 ACM が存在しない場合の ACM に設定される BCI の設定値について ※180 Ringing についてのみの記述 ・Profile A (モバイル)の場合 Charge indicator: 記述無し Called party's status indicator: ⇒01subscriber free Called party's category indicator: 記述無し End-to-end method indicator: 記述無し Interwork Indicator: ⇒1 Interwork encountered End-to-end information indicator: 記述無し ISDN user part indicator: ⇒0 ISDN user part/BICC not used all the way Holding indicator: 記述無し ISDN access indicator ⇒0 terminating access non-ISDN Echo control device indicator: 記述無し SCCP method indicator: 記述無し ・Profile B の場合 Called party's status indicator: ⇒01subscriber free その他 Interwork Indicator, ISDN user part indicator, ISDN access indicatorについては、様々な情報に応じて設定される。</p>	<p>・181、182 のインタワークについての記述有無。 ・183 は、Q.1912.5 ではインタワークされない。 ・カプセル化に関して、JF-IETF-RFC3398 では、仕様規定範囲外。 ・Profile B の場合 Q.1912.5 では、Called party's status indicator 以外の要素は状況に応じて設定され、JF-IETF-RFC3398 では、左記のようにデフォルト値が規定されている。 ・Profile A の場合、JF-IETF-RFC3398 では、BC 内 Called party's status indicator の設定値として 00 no indication がサポートされる。 ・Profile A の場合、BCI 内 Interwork Indicator について、Q.1912.5 では 1、JF-IETF-RFC3398 では 0 にインタワークされる。 ・Profile A の場合、BCI 内 ISDN user part Indicator について、Q.1912.5 では 0、JF-IETF-RFC3398 では 1 にインタワークされる。</p>

項番	項目	JF-IETF-RFC3398	ITU-T 勧告(Q.1912.5)	差分内容
			※Profile C については、180 Ringing 内に ACM がカプセル化されることが規定されている。そのため、特に記述無し。	
16	2XX 受信のインタワーク	<p>(1)インタワーク方法<8.2.4 章参照> 最終レスポンスである 200OK を受信した場合、PSTN に ANM、SIP 網に ACK を送らなければならない。ゲートウェイが、もし非 INVITE 要求に対する 200 OK を受信する場合には、PSTN 網へ ISUP メッセージを送るべきではない。</p> <p>※JF-IETF-RFC3398 では、(JJ-90.10 注) 接続メッセージ(CON)の送出不が許容されないため、アドレス完了メッセージ(ACM)および応答メッセージ(ANM)の 2 つのメッセージにマッピングを行う。</p> <p>●カプセル化した 2XX レスポンス受信のインタワーク 【本仕様規定範囲外】 ※RFC3398 上では記述有り。 正当で理解可能な ANM が 200 OK にカプセル化される時、ゲートウェイは PSTN に送る ANM に、適切な ISUP パラメータを再利用すべきである。</p>	<p>(1)インタワーク方法 <7.5 章参照> ①ISUP メッセージが 200OK にカプセル化されていない場合 ((Profile A, Profile B の場合)、タイマ TOIW2 が起動している場合は停止し、ANM か CON を送信する。 ②ISUP メッセージが 200OK にカプセル化されている場合 (Profile C の場合)、CON か ANM がカプセル化された ISUP メッセージを元に、適切なメッセージを送信する。</p>	<ul style="list-style-type: none"> ・ACK と非 INVITE 要求に対する 200OK に関する記述の有無。 ・カプセル化に関して、JF-IETF-RFC3398 では仕様規定範囲外。
17	3XX 受信のインタワーク	<p>(1)インタワーク方法 <8.2.5 章参照> 3XX 受信時したゲートウェイはその受信した 3XX レスポンスの Contact ヘッダフィールドが示す URI を参照して、新規の呼接続を試みるべきである。</p> <p>【ISUP へのインタワーク】 もし 3XX レスポンスが示す URI が ISUP 網へのリダイレクションを示唆する場合、ゲートウェイのルーティング・ポリシーに従って、IAM にインタワークするべきである。 ゲートウェイは、上記の IAM へのインタワークの代わりに、リダイレクション表示、診断フィールドの情報要素を持つ REL メッセージを ISUP 網へインタワークするかもしれない。</p> <p>【SIP へのインタワーク】 もし 3XX レスポンスが示す URI が SIP 網へのリダイレクションを示唆する場合、MGC は Request-URI を更新して、新規の INVITE を送信するべきである。また、新規 INVITE に新規に生成した IAM をカプセル化するべきである。</p>	<p>(1)インタワーク方法 記述なし。</p>	<ul style="list-style-type: none"> ・インタワーク方法の記述の有無。
18	4xx、5xx、6xx 受信のインタワーク	<p>(1)インタワーク方法<8.2.6 章参照> 400 以上のステータスコードを受信したゲートウェイはゲートウェイリソースを解放し、理由表示値を設定した REL を PSTN に送り、SIP 網に ACK を送るべきである。 PSTN に REL を送る時、ゲートウェイは開放処理が完了したことを示す RLC の到着を期待する。</p> <p>①マッピングについて 付表 3 のマッピングを適用する。 404 に理由表示値#1 を持つ Reason ヘッダが付与されている場合について、REL (理由表示値 #1) へとマッピングされる。それ以外の SIP レスポンス受信時の REL (理由表示値 #1) へのマッピングについては、注意が必要。 ※但し、JF-IETF-RFC3398 では“理由表示値のマッピングに関しては、基本的に各事業者マターであり、上記は推奨値として用いる。 TTC ISUP においては、本節に記述されるすべての理由表示値を規定しているわけではな</p>	<p>(1)インタワーク方法<7.7.6 章参照> PSTN 側に REL を送信する。 SIP 側の手順によっては、REL にインタワークされないかもしれない。(例えば、401 受信時には、正しい認証を備えた INVITE を送信する場合など) ①マッピングについて Reason ヘッダが含まれている場合、Q.850 で規定される Cause Value を使用する。含まれていない場合は、付表 3 のマッピングを適用する。 ②カプセル化された REL が存在する場合 そのままカプセル化されていた REL を送信する。</p>	<ul style="list-style-type: none"> ・Cause Value について ・Q.1912.5 では、REL が送信されないケースも存在する。 ・カプセル化に関して、JF-IETF-RFC3398 では仕様規定範囲外。

項番	項目	JF-IETF-RFC3398	ITU-T 勧告(Q.1912.5)	差分内容
		<p>い。</p> <p>TTC ISUPにおいて規定されていない理由表示値のマッピングについては、今後整理される必要がある。</p> <p>②カプセル化された REL が存在する場合【本仕様規定範囲外】</p> <p>※RFC3398 上では記述有り。</p> <p>カプセル化された REL の理由表示パラメータ (CAI) を適用すべきである。</p>		
19	REL 受信のインタワーク (ISUP 側発信時)	<p>(1)インタワーク方法<8.2.7 章参照></p> <p>本事象は、一般にPSTN側のユーザが、要求に応答がある前に受話器を置く時に起こる。ゲートウェイはセッションの設定を中止する。CANCEL リクエストが発行されなくてはならない。CANCEL に対して 200OK が期待され、最終的に INVITE に対して 487 送信される。(ゲートウェイが順に ACK する)。</p> <p>元々の INVITE の 200 最終応答が (CANCEL の 200 OK 受信後でも) 来るかもしれないので、ゲートウェイはある一定時期このダイアログと関係がある状態情報を保持すべきである。この状態で、ゲートウェイは ACK と BYE リクエストを送信する。</p> <p>・SIPブリッジである場合【本仕様規定範囲外】</p> <p>※RFC3398 上では記述有り。</p> <p>REL メッセージは、CANCEL メッセージにカプセル化はできない (CANCEL がメッセージボディを持たないため)。通常、REL メッセージは、理由表示値 16 を含むであろう。もし値が 16 以外の場合、ゲートウェイは理由表示値を伝達する他の手段を望むかもしれない。</p>	<p>(1)インタワーク方法 <7.7.1 章参照></p> <p>・INVITE 前の REL 受信時 何もしない。</p> <p>・INVITE に対する応答受信前の REL 受信 O-IWU は、REL 受信まで待機する。その後、以下の動作のどちらかを行う。</p> <p>・Early ダイアログ、ダイアログ確立前の REL 受信 CANCEL を送信する。</p> <p>INVITE に対する 200OK を受信し、ACK を送信していない状態においては、ACK の送信した後、BYE を送信する。</p> <p>・Early ダイアログ、ダイアログ確立後の REL 受信 BYE を送信する。</p> <p>ただし、Early ダイアログの場合は、CANCEL が使用されるかもしれない。</p>	<p>・CANCEL 処理による 487 送信に関する記述の有無。</p> <p>・Early ダイアログが確立前/確立後の場合における REL 受信時の動作についての記述の有無。</p>
20	保留	<p>(1)インタワーク方法<9.2 章参照></p> <p>保留に関する手順についてサポートされない (RFC3398 では CPG へのインタワークが記述される)。</p> <p>上記制限に関わらず動作を行う場合の推奨動作</p> <p>・PSTN 側 インタワークなし</p> <p>・SIP 側</p> <p>200 OK を送信 (音声パケット送受の停止を行う場合)</p> <p>488 Not Acceptable Here (音声パケット送受の停止を行わない場合、MGC において呼を継続すること。)</p> <p>※なお、上記を含めてパス接続に関しては、各事業者マターと記述あり。</p>	<p>(1)インタワーク方法<Annex B.10 参照></p> <p>呼の確立後、または、サービスプロバイダによるオプションとして付加的に、呼は発信者により保留状態にされるかもしれない。</p> <p>※Annex B.10 にて、メディアストリーム停止について、メッセージのマッピングなど、詳細について記述あり (メディアストリーム停止拒否の場合における動作について記述なし)。</p>	<p>・保留動作について、JF-IETF-RFC3398 では保留に関する手順はサポートされない。</p> <p>・保留動作時の PSTN 側へのインタワーク動作に関する記述の有無。</p> <p>・SIP 側での、保留リクエストに受信時における、メディアストリーム停止拒否の場合における動作についての記述の有無。</p>
21	SIP initiated release	<p>(1)インタワーク方法 <10.1 章参照></p> <p>標準対話終了 (BYE 要求の受信) で、ゲートウェイはすぐに 200 応答を送らなくてはならない。その後ゲートウェイはリソースを解放し (DSP、TCIC ロックなど)、PSTN に理由表示値 16 の REL を送らなくてはならない。リソース解放は PSTN 側では RLC メッセージで確認される。</p> <pre> SIP -----MGC/MG-----PSTN 1 -----BYE-----> ** MG Releases IP Resources ** 2 <-----200----- ** MG Releases PSTN Trunk ** -----REL-----> 3 <-----RLC----- 4 </pre> <p>①SIPブリッジである場合【本仕様規定範囲外】</p> <p>※RFC3398 上では記述有り</p>	<p>(1)インタワーク方法 <7.7.2 章参照></p> <p>Q.850 の値を持った Reason ヘッダが BYE に含まれる場合、ローカルポリシーに従い、REL 内の ISUP 理由表示値にマッピングされるかもしれない。もし、使用可能な Reason ヘッダがない場合、Cause Value No.16 (“Normal clearing”) が REL に挿入される。</p> <pre> Normal call release SIP NNI I-IWU PSTN -----BYE-----> -----REL-----> <-----200----- <-----RLC----- </pre> <p>※上記動作は、I-IWU が BYE を受け取ったと同時に、200 の返答と、REL の送信が行われる。</p>	<p>・BYE が Q.850 の値を持った Reason ヘッダを含む場合についての記述の有無。</p>

項番	項目	JF-IETF-RFC3398	ITU-T 勧告(Q.1912.5)	差分内容
		BYEにカプセル化したRELの理由表示値を、ゲートウェイがPSTNに送るRELに再利用するべきである。		
22	SUS、RES受信のインタワーク	(1)インタワーク方法 <9.1、10.2.2 章参照> ①SIPブリッジでない場合 SUSがPSTNから来るとき、MGCは相手UAのメディアストリームを止めるように要求するためにINVITEを送ってもよい。 あるPSTNシナリオで、もし発信者が呼の途中で受話器を置くと、ローカル交換機はRELの代わりにSUSを送り、タイマを起動する(T6、ネットワーク起動SUS)。タイマの期限が切れるとPSTN側にREL、SIP側にBYEが送信される。 ②SIPブリッジである場合 【本仕様規定範囲外】 ※RFC3398上では記述有り。 PSTNからSUSを受け取ったGWがメディア停止を要求しない場合、INFOメソッドがカプセル化SUSを転送されるのに使われるかもしれない。	(1)インタワーク方法 <6.9、6.10 章参照> ①SIPブリッジでない場合 SUS、RESはインタワークされない。 ②SIPブリッジである場合 SUS、RESがINFOリクエストのMIMEボディの中にカプセル化される。	・SUSのインタワーク方法について、Q.1912.5ではSUS、RESはインタワークされない。 ・SIPブリッジについて、JF-IETF-RFC3398では仕様規定範囲外。
23	SAM受信のインタワーク	(1)インタワーク方法 <4 章参照> 【本仕様規定範囲外】 ※RFC3398においても仕様規定範囲外	(1)インタワーク方法 <7.2 章参照> ・タイマが起動中なら、TOIW3を停止する。 ・TOIW2が再開され、以下の内容を加味すること。 a)新規INVITEのRequest-URIとTo header fieldは、この呼がこれまで受け取った数字を全て含む。 b)前のINVITEと同一のCall-ID、tagを含むFrom headerの新規INVITEが送られる。 c)新規INVITEはSDP情報を含む。 d)新規INVITEの他の全てのパラメータは、IAMパラメータをインタワークする。	・JF-IETF-RFC3398では、仕様規定範囲外。
24	INVITE→SAMのインタワーク	(1)インタワーク方法 <4 章参照> 【本仕様規定範囲外】 ※RFC3398においても規定範囲外	(1)インタワーク方法 <6.2 章参照> 前回のINVITEと同じCall-ID、From tagを持つINVITEを受信した場合、Request-URIの桁数が既に蓄積された桁数より大きな場合、I-IWUはSAMを生成する。	・JF-IETF-RFC3398では、仕様規定範囲外。
25	CON受信のインタワーク	(1)インタワーク方法 <7.2.7 章参照> 【本仕様規定範囲外】 ※RFC3398において、SIPブリッジの場合について記述有り。 ①SIPブリッジでない場合 SIPネットワーク側に200OKを送信する。 ②SIPブリッジの場合 SIPブリッジの場合で、(INVITEが理解可能な正しいカプセル化ISUPメッセージを含む場合)、ISUPメッセージは200 OKのボディ部に含められる。 ③インタワーク時のメディアについて CONを受信すると、200 OK 応答がSIPネットワークに送られる。200 OKはINVITEで提案したメディアの応答を含むべきである。	(1)インタワーク方法 <6.4 章参照> ①SIPブリッジでない場合 INVITEに対する200OKを送信する。 ②SIPブリッジの場合 Profile C(SIP-I)の場合、CONは、INVITE最終レスポンス(200 OK)でカプセル化される。 ③インタワーク時のメディアについて 記述無し。	・JF-IETF-RFC3398では、仕様規定範囲外。
26	ISUPメンテナンスメッセージのインタワーク	(1)インタワーク方法 <11 章参照> RSC、GRA 現在ゲートウェイが呼に使用している回線でRSCメッセージを受信した場合、呼はすぐに開放されなく、RSCに対してRLCを返答する。 広範囲の回線を対象とした回線群リセット(GRS)メッセージの場合、メッセージの対象とするすべての回線をリセットした後で、GRAを返送する。 SIP網に対しては、RELを受信したように、振る	(1)インタワーク方法 <7.7.4 章参照> ①セッションが確立されている場合 BYEを送信。(ISUPの手順により、RELが生成され、カプセル化されて含まれる。) ※発側/着側となっているPSTN網どちらから受信した場合でも同様の動作。 ②セッションが未確立の場合 ・着側となっているPSTN網から受信した場合(I-IWUでの受信) 500 Server Internal Errorを送信 (ISUPの	・PSTN網が発側/着側かどうかの場合分けについて、JF-IETF-RFC3398では記述あり。 ・セッション未確立時のRSC、GRSのインタワーク動作について、Q.1912.5では、500Server Internal Errorを送信し、JF-IETF-RFC3398では、

項番	項目	JF-IETF-RFC3398	ITU-T 勧告(Q.1912.5)	差分内容
		<p>舞うべきであり、呼状態によって、BYE が CANCEL が送信される。 ※セッションが未確立の場合 CANCEL を送信</p> <p>BLO 閉塞メッセージ(BLO)は常に管理指向で、回線が閉塞された時、ゲートウェイは閉塞確認メッセージ(BLA)で応答インタワークの必要なし。</p> <p>CGB 回線群閉塞メッセージ(CGB)が回線群管理メッセージ種別表示の中に「種別表示」を持つ。この種別表示は、管理かハードウェア故障を示す。もし CGB がハードウェア障害によって生じるなら、各回線の影響範囲の呼が REL 受信のようにすぐに終了しなくてはならない。CGB に対して CGBA で応答しなければならない。 ※上記全てに関して、RSC などを送信する PSTN 網が発側/着側かどうかの場合分けについての記述なし。</p>	<p>手順により、REL が生成され、カプセル化されて含まれる。 ・発側となっている PSTN 網から受信した場合 (O-IWU での受信) CANCEL を送信 (SIP ブリッジの場合でも、ISUP メッセージはカプセル化されない。)</p> <p>BLO ISUP 側の呼の手順のみ関わるメッセージであり、カプセル化されない。SIP メッセージにカプセル化されて送られてきた場合は、ISUP 情報は廃棄される。</p> <p>※上記全てに関して、CGB についてはハードウェア障害についてのみ記述あり。 その他、Q.763にて"national use"とマークされるメッセージについて記述あり。<5.4.3 章参照></p>	<p>CANCEL を送信する。 ・BLO の受信時動作について、JF-IETF-RFC3398 では BLA で応答と記述あり。 ・RSC,GRS,CGB,BLO 以外の記述について、Q.1912.5 では、Q.763 にて規定されるその他の "national use"とマークされるメッセージについての記述があるが、JF-IETF-RFC3398 では、記述がない。</p>
27	Timer に関して	<p>(1)タイマに関して ・ISUP タイマ T6(SUS 受信時)<10.2.2 章参照> ・ISUP タイマ T7(INVITE 受信→IAM 送信後)<7.1.3 章、7.2.2 章参照> ・ISUP タイマ T9(ACM 受信時)<7.2.8 章、8.1.4 章参照> ・ISUP タイマ T11(IAM 受信→INVITE 送信後)<8.1.3 章、8.2.8 章参照> ・SIP タイマ T1(SIP 発:ANM 受信→200 OK 送信後、PSTN 発:IAM 受信→INVITE 送信後)<7.1.4、8.1.3 章参照> のインタワークタイマが定義されている。</p> <p>ISUP タイマ T7 PSTN から応答がないと、MG のすべての資源は解放し、'504 Server Timeout' が SIP ネットワークに送り返されるべきである。 理由表示値 102 の REL メッセージが PSTN 網に送られるべきである。</p> <p>ISUP タイマ T6 SUS 送信後、T6 タイマが起動する。タイマの期限が切れると、SIP 側に BYE、PSTN 側に REL が送信される。</p> <p>ISUP タイマ T9 このタイマのタイムアウトは、この呼で呼び出し開始後一定期間経っても ANM が到着しなかったことを示す。 通常、これは着信者端末が呼び出されたが誰も応答しなかったことを意味する。このタイマが満了した場合、呼は開放されなければならない。メディアパスと関係があるゲートウェイ資源のすべてが開放されるべきである。 '480 Temporarily Unavailable' 応答が SIP ネットワークに送られるべきである。 理由表示値 19 の REL メッセージが ISUP ネットワークに送られるべきである。PSTN からは RLC 応答を待ち、SIP ネットワークからは解放処理の完了を示す ACK を待つ。 ※ISUP タイマ T9 に関する JF-IETF-RFC3398 の注釈 本仕様では、ITU-T Q.764 で規定される T9 と同等の規定に従う「ANM 待ちインタワークタイマ」を規定する。本節の "Timer T9" および "T9" はこの「ANM 待ちインタワークタイマ」と読み替える。</p>	<p>(1)タイマに関して ・ISUP タイマ T7(INVITE 受信→IAM 送信後)<6.11.3 章参照> ・ISUP タイマ T8(導通試験メッセージ受信時(CCR 受信時))<7.1 章 A)参照> ・TOIW1(アドレス不備の INVITE/SAM 受信時)、TOIW2(INVITE 送信→ACM 未受信時)、TOIW3(484 受信時)の 3 種類のタイマが定義されている。<7.8 章参照></p> <p>ISUP タイマ T7 での動作 I-IWU にて T7 が Expire したとき、PSTN 側は ISUP 手順に従い動作し、SIP 側に対しては '484Address Incomplete' を送信する。</p> <p>TOIW1 4~6 秒(デフォルト 4 秒) 番号 digit が足りない(ルーティングに必要な数より少ない)IAM か SAM で、を受信したとき、このタイマが起動する。 正常なアドレス情報を受け取れず、タイマが満了した場合、ProfileA、B のみに適用され、Initial INVITE と、ACM を送信し、ダイヤルトーン等応答待ち表示か、適切なアナウンスを発信者に送信する。</p> <p>TOIW2 4~14 秒(デフォルト 4 秒) ACM が送られていない状態で、INVITE を送信したときに起動される。 484 エラー、100、180、183、200OK(INVITE)を受け取れず、タイマが満了した場合、ProfileA、B のみに適用され Early ACM を送信し、ダイヤルトーン等応答待ち表示か、適切なアナウンスを発信者に送信する。</p> <p>TOIW3 4~6 秒(デフォルト 4 秒) 他に INVITE トランザクションが待ち状態がなく、現在の INVITE に対して 484 Address Incomplete を受け取ったとき、このタイマが起動する。 正常なアドレス情報を受け取れず、タイマが満了したとき、Cause Value 28 を持つ REL を ISUP/BICC 側に送信する。</p>	<p>・Q.1912.5 では独自のタイマ TOIW タイマを規定する。 ・ISUP T7 タイマ満了時、SIP 側に対し、Q.1912.5 では 484 Address Incomplete を送信し、JF-IETF-RFC3398 では 504 Server Timeout を送信する。 PSTN 側は、Q.1912.5 では ISUP 手順に従い動作し、JF-IETF-RFC3398 では、Cause Value 102 の REL を送信すると記述される。 ・SIP タイマと ISUP タイマの記述の有無。</p>

項番	項目	JF-IETF-RFC3398	ITU-T 勧告(Q.1912.5)	差分内容
		<p>TTC ISUPとしてはT9は規定していないが、SIP-ISUPのインタワークにおいて、インタワークタイマとしてACM受信後のANM待ちタイマが必要となる。(呼設定中の発側SIP網(ユーザ含む)障害等で着側端末が呼び出し状態のままとなり、網内リソースも保持されたままとなる可能性等があるためである。)</p> <p>ISUP タイマ T11 もしゲートウェイがこのオプションのメカニズムをサポートするならば、もしT11がタイムアウトするならば、遠隔ノードのT7のタイムアウトを妨げるために、Early ACM(つまり着信者状態が「表示なし」を送るべきである。 もし、180メッセージがその後到着するならば、8.2.3章に示されるようにCPGで送られるべきである。</p> <p>SIP タイマ T1 ・SIP 発の場合 200OKを7回再送した後(T1タイムアウト後)、ISUP側に理由表示値102のRELを送信。 ・PSTN 発の場合 SIPタイマT1満了までに、ISUPタイマT11が満了するので、ISUP側にCalled Party's Statusをno indicationとしたACMを送信し、その後INVITEを7回再送した後(T1タイムアウト後)、呼を終了するため理由表示値18のRELをISUPに送信し、SIP側にはCANCELを送信する。</p>		
28	自律動作について(タイマ動作除く)	自律動作について記述なし。	<p>自律動作について<6.11.3章,7.7.3章参照> I-IWUの場合 ・I-IWUでの輻輳時の動作 PSTN側 適用されない。 SIP側 480 Temporarily Unavailableを送信。 ・I-IWUが不明なISUP信号情報または、Q.764 2.9.5.2章を参照とする互換表示に基づいた呼の解放動作 PSTN側 ISUP手順に基づく。 SIP側 500 Internal Server Errorを送信。 ・ISUPからの応答受信後の別ISUP手順受信時の動作 PSTN側 ISUP手順に基づく。 SIP側 BYEを送信。 ・ISUPからの応答受信前の別ISUP手順受信時の動作 PSTN側 ISUP手順に基づく。 SIP側 480 Temporarily Unavailableを送信。</p> <p>O-IWUの場合 ・O-IWUにて、導通表示が"continuity check failed"となっているCOTを受信、または、T8タイマが満了した場合 PSTN側 ISUP手順に基づく。 SIP側 7.7.1章に基づき、CANCEL/BYEを送信。 ・リソース確保に失敗した場合 PSTN側 理由表示値47のRELを送信。 SIP側 SIP手順に基づく。 ・ISUP手順に基づき、ISUP側に自律的にRELを送信する場合 PSTN側 ISUP手順に基づく。 SIP側 7.7.1章に基づき、CANCEL/BYEを送信。 ・SIP手順に基づき、呼が開放される場合</p>	・自律動作全ての記述の有無。

項番	項目	JF-IETF-RFC3398	ITU-T 勧告(Q.1912.5)	差分内容
			<i>PSTN 側 SIP の開放理由に依存し動作する。</i> <i>SIP 側 SIP 手順に基づく。</i>	

付表 ii -2/JF-IETF-RFC3398 ISDN 理由表示値から SIP ステータスコードへのマッピング

REL (Cause Indicators parameter)	方向	SIP レスポンス (JF-IETF-RFC3398) <7.2.4.1 章参照>	SIP レスポンス (Q.1912.5) <6.11.1 章, 6.11.2 章参照>
Cause Value No. 1 (“unallocated (unassigned) number”)	→	404 Not Found(理由表示値#1を持つ Reason ヘッダを含む) Reason ヘッダ例 Reason:Q.850;cause=1;text=“unallocated number”	404 Not Found
Cause Value No. 2 (“no route to network”)		404 Not Found	500 Server Internal Error
Cause Value No. 3 (“no route to destination”)		404 Not Found	500 Server Internal Error
Cause Value No. 4 (“Send special information tone”)		500 Server Internal Error	500 Server Internal Error
Cause Value No. 5 (“Misdialed trunk prefix”)		500 Server Internal Error	404 Not Found
Cause Value No. 8 (“Preemption”)		500 Server Internal Error	500 Server Internal Error (SIP-I only)
Cause Value No. 9 (“Preemption-circuit reserved for reuse”)		500 Server Internal Error	500 Server Internal Error (SIP-I only)
Cause Value No. 16 (“normal call clearing”)		—(*)	通常切斷(**)
Cause Value No. 17 (“user busy”)		486 Busy Here	486 Busy Here
Cause Value No. 18 (“no user responding”)		408 Request Timeout	480 Temporarily unavailable
Cause Value No. 19 (“no answer from the user”)		480 Temporarily unavailable	480 Temporarily unavailable
Cause Value No. 20 (“subscriber absent”)		480 Temporarily unavailable	480 Temporarily unavailable
Cause Value No. 21 (“call rejected”)		403 Forbidden(+)	480 Temporarily unavailable
Cause Value No. 22 (“number changed (w/o diagnostic) ”)		410 Gone	410 Gone
Cause Value No. 22 (“number changed(w/ diagnostic)”)		301 Moved Permanently	410 Gone
Cause Value No. 23 (“redirection to new destination”)		410 Gone	No mapping
Cause Value No. 25 (“Exchange routing error”)		500 Server Internal Error	480 Temporarily unavailable
Cause Value No. 26 (“non-selected user clearing”)		404 Not Found	※Q.850 クラスデフォルトの値がマッピングされる
Cause Value No. 27 (“destination out of order”)		502 Bad Gateway	502 Bad Gateway
Cause Value No. 28 (“invalid number format (address incomplete)”)		484 Address Incomplete	484 Address Incomplete
Cause Value No. 29 (“facility rejected”)		501 Not implemented	500 Server Internal Error
Cause Value No. 31 (“normal unspecified”)(Class default)		480 Temporarily unavailable	480 Temporarily unavailable
Cause Value in the Class 010 (resource unavailable, Cause Value No. 34)		503 Service Unavailable	486 Busy here if Diagnostics Indicator includes the (CCBS indicator = “CCBS possible”) else 480 Temporarily unavailable
Cause Value in the Class 010 (resource unavailable, Cause Value No. 38-47) (47 is class default)		500 Server Internal Error 一部については(Cause Value No.38,41,42,47)は、以下に記述	500 Server Internal Error
Cause Value No. 38 (“ network out of order ”)		503 Service Unavailable	500 Server Internal Error
Cause Value No. 41 (“ temporary failure ”)		503 Service Unavailable	500 Server Internal Error
Cause Value No. 42 (“ switching equipment congestion ”)		503 Service Unavailable	500 Server Internal Error
Cause Value No. 47 (“ resource unavailable ”)		503 Service Unavailable	500 Server Internal Error
Cause Value No. 50 (“requested facility not subscribed”)		500 Server Internal Error	500 Server Internal Error
Cause Value No. 55 (“incoming calls barred within CUG”)		403 Forbidden	500 Server Internal Error (SIP-I only)
Cause Value No. 57 (“bearer capability not authorized”)		403 Forbidden	500 Server Internal Error
Cause Value No. 58 (“bearer capability not presently”)		503 Service Unavailable	500 Server Internal Error
Cause Value No. 63 (“service option not available, unspecified”)(Class default)		500 Server Internal Error	500 Server Internal Error
Cause Value in the Class 100 (service or option not implemented Cause Value No. 65 - 79) (79 is class default)		500 Server Internal Error 一部については(Cause Value No.65,70,79)は、以下に記述	500 Server Internal Error
Cause Value No. 65 (“ bearer capability not implemented ”)		488 Not Acceptable Here	500 Server Internal Error
Cause Value No. 70 (“ only restricted digital avail ”)		488 Not Acceptable Here	500 Server Internal Error
Cause Value No. 79 (“ service or option not implemented ”)		501 Not Implemented	500 Server Internal Error
Cause Value No. 87 (“user not member of CUG”)		403 Forbidden	500 Server Internal Error (SIP-I only)
Cause Value No. 88 (“incompatible destination”)	→	503 Service Unavailable	500 Server Internal Error
Cause Value No. 90 (“Non-existent CUG”)		500 Server Internal Error	500 Server Internal Error (SIP-I only)
Cause Value No. 91 (“invalid transit network selection”)		500 Server Internal Error	404 Not Found

REL (Cause Indicators parameter)	方向	SIP レスポンス (JF-IETF-RFC3398) 〈7.2.4.1 章参照〉	SIP レスポンス (Q.1912.5) 〈6.11.1 章, 6.11.2 章参照〉
Cause Value No. 95 (“invalid message”) (Class default)		500 Server Internal Error	500 Server Internal Error
Cause Value No. 97 (“Message type non-existent or not implemented”)		500 Server Internal Error	500 Server Internal Error
Cause Value No. 99 (“information element/parameter non-existent or not implemented”)		500 Server Internal Error	500 Server Internal Error
Cause Value No. 102 (“recovery on timer expiry”)		504 Gateway Timeout	480 Temporarily unavailable
Cause Value No. 103 (“Parameter non-existent or not implemented, pass on”)		500 Server Internal Error	500 Server Internal Error
Cause Value No. 110 (“Message with unrecognized Parameter, discarded”)		500 Server Internal Error	500 Server Internal Error
Cause Value No. 111 (“protocol error, unspecified”) (Class default)		500 Server Internal Error	500 Server Internal Error
Cause Value No. 127 (“interworking unspecified”) (Class default)		500 Server Internal Error	480 Temporarily unavailable
<p>注 1: JF-IETF-RFC3398 では、表に記載の無い Cause Value は、500 Server Internal error へマッピング。 * : Cause Value 16 は通常 BYE か CANCEL、呼完了前は 480Temporary unavailable ** : 呼完了前ならば、480Temporary unavailable + : Cause location='user' の場合、4xx→6xx になる。</p>			

付表 ii -3/JF-IETF-RFC3398 SIP ステータスコードから ISDN 理由表示値へのマッピング

SIP レスポンスの状態コード	方向	REL の Cause Value(JF-IETF-RFC3398) <8.2.6.1 章参照>	REL の Cause Value(Q.1912.5) <7.7.6 章参照>
400 Bad Request	→	41 Temporary Failure	127 Interworking
401 Unauthorised		21 Call rejected (*)	127 Interworking (Note 1)
402 Payment Required		21 Call rejected	127 Interworking
403 Forbidden		21 Call rejected	127 Interworking
404 Not Found (理由表示値#1 をもつ Reason ヘッダを含む) Reason ヘッダ例 Reason:Q.850;cause=1 上記以外の 404 Not Found		1 Unallocated number	1 Unallocated number
		※理由表示値#1 へのマッピングには注意が必要	1 Unallocated number
405 Method Not Allowed		63 Service or option unavailable	127 Interworking
406 Not Acceptable		79 Service/option not implemented (+)	127 Interworking
407 Proxy authentication required		21 Call rejected (*)	127 Interworking (Note 1)
408 Request Timeout		102 Recovery on timer expiry	127 Interworking
410 Gone		22 Number changed (without diagnostic)	22 Number changed (without diagnostic)
413 Request Entity too long		127 Interworking (Note 1)	127 Interworking (Note 1)
414 Request-uri too long		127 Interworking (Note 1)	127 Interworking (Note 1)
415 Unsupported Media type		79 Service/option not implemented (+)	127 Interworking (Note 1)
416 Unsupported URI scheme		127 Interworking (+)	127 Interworking (Note 1)
420 Bad Extension		127 Interworking (+)	127 Interworking (Note 1)
421 Extension required		127 Interworking (+)	127 Interworking (Note 1)
423 Interval Too Brief		127 Interworking	127 Interworking
480 Temporarily Unavailable		18 No user responding	20 Subscriber absent
481 Call/Transaction does not exist		41 Temporary Failure	127 Interworking
482 Loop Detected		25 Exchange - routing error	127 Interworking
483 Too many hops		25 Exchange - routing error	127 Interworking
484 Address Incomplete		28 Invalid Number Format (+)	28 Invalid Number format (Note 1)
485 Ambiguous		1 Unallocated number ※但し、理由表示値#1 へのマッピングには注意が必要	127 Interworking
486 Busy Here		17 User busy	17 User busy
487 Request terminated		— (no mapping)	127 Interworking or no mapping. (Note 2, 3)
488 Not acceptable here		— by Warning header	127 Interworking
491 Request Pending		31 Normal unspecified	No mapping (Note 2)
493 Undecipherable		31 Normal unspecified	127 Interworking
500 Server Internal error		41 Temporary failure	127 Interworking
501 Not implemented		79 Not implemented, unspecified	127 Interworking
502 Bad Gateway		38 Network out of order	127 Interworking
503 Service Unavailable		41 Temporary failure	127 Interworking (Note 1)
504 Server timeout		102 Recovery on timer expiry	127 Interworking
505 Version not supported		127 Interworking (+)	127 Interworking (Note 1)
513 Message too large		127 Interworking (+)	127 Interworking (Note 1)
580 Precondition failure		31 Normal unspecified	127 Interworking (Note 1)
600 Busy Everywhere		17 User busy	17 User busy
603 Decline		21 Call rejected	21 Call rejected
604 Does not exist anywhere		1 Unallocated number ※但し、理由表示値#1 へのマッピングには注意が必要	1 Unallocated number
606 Not acceptable		— by Warning header	127 Interworking

注 1: Q.1912.5 において、127Interworking へのインタワークでは、BI に "network beyond interworking" がセットされる。
注 2: JF-IETF-RFC3398 では、この表でマッピングされないものに関しては、Cause Value No.31 (normal unspecified) にマッピングされる。
*: ゲートウェイがそれ自身を認証できない場合、cause code 21 が送られるべきである。
+: もし、可能であるなら、SIP ゲートウェイが適切でない動作を修正し、セッションを再生成しようと試み、プロトコルエラーを返答するべき。
もし、不可能ならば、SIP ゲートウェイが ISUP 側の呼を接続できない。
Note1: SIP 側で完全に扱われる場合は、インタワークされない。
Note2: SIP dialog は終了せず、その中の特定の処理のみ終了する。
Note3: INVITE に対する CANCEL をそれ以前に送出していた場合は、インタワークされない。

付表 ii-4/JF-IETF-RFC3398 ISDN アクセス表示に「非 ISDN アクセス」を持つ IAM へのインタワーク
 における ISUP デフォルト設定値の差分

パラメータ	要素	JF-IETF-RFC3398 <付属資料 a 参照>	ITU-T 勧告(Q.1912.5)
接続特性表示	衛星回線表示	00 接続において衛星回線なし 01 接続において衛星回線 1 回線あり 10 接続において衛星回線 2 回線あり から値を設定。衛星回線の使用状況が不明の場合 は"00"を設定。	•Profile A、Profile B <6.1.3.3 章 Table4 参照> 01 接続において衛星回線 1 回線あり
	導通試験表示	00 導通試験不要を設定。 10 前位で導通試験実施の適用は今後の課題。	前提条件リクエストが終えている場合<6.1.3.3 章 Table4 参照> 00 導通試験不要 前提条件リクエストが継続中の場合<6.1.3.3 章 Table4 参照> 10 前位にて導通試験実施
	エコー制御装置 表示	0 出回線ハーフエコー制御装置挿入せず 1 出回線ハーフエコー制御装置挿入 "0","1"の一方を設定。	•Profile A <6.1.3.3 章 Table4 参照> 1 出回線ハーフエコー制御装置挿入 •Profile B 記述なし
順方向呼表示	国内/国際呼表 示	0 国内呼として処理される呼を設定。 1 国際呼として処理される呼の適用(国際呼)は将来に おける検討事項。	※最新の BICC/ISUP 勧告に基づくべきであると記 述あり。<6.1.3.4 章参照>
	エンド・エンド法 表示	00 エンド・エンド法が利用できないを設定。	※最新の BICC/ISUP 勧告に基づくべきであると記 述あり。<6.1.3.4 章参照>
	相互接続表示	0 相互接続なしを設定。	•Profile A <6.1.3.4 章 Table5 参照> 1 相互接続ありを設定 •Profile B <6.1.3.4 章参照> 適切な値を設定。
	エンド・エンド情 報表示	0 エンド・エンド情報利用できないを設定。	※最新の BICC/ISUP 勧告に基づくべきであると記 述あり。<6.1.3.4 章参照>
	ISUP1 リンク表示	1 ISUP1 リンクであることを設定。	•Profile A <6.1.3.4 章 Table5 参照> 0 ISUP1 リンクでないを設定。 •Profile B <6.1.3.4 章参照> 適切な値を設定。
	ISUP1 リンク希望 表示	00 ISUP1 リンクを希望するが必須ではない 10 ISUP1 リンクを希望し必須である のいずれかを設定。	•Profile A <6.1.3.4 章 Table5 参照> 01 ISUP1 リンクを希望しないを設定。 •Profile B <6.1.3.4 章参照> 適切な値が設定。
	ISDN アクセス表 示	0 発側のユーザ・網インタフェースが非 ISDN を設定。 ※"1 発側ユーザ・網インタフェースが ISDN"を適用す る場合は JT-Q699 に従い、未規定部分は付属資料 a.1 に従うと記述あり。<7.2.1.1 章参照>	• Profile A <6.1.3.4 章 Table5 参照> 0 発側のユーザ・網インタフェースが非 ISDN を設 定。 •Profile B <6.1.3.4 章参照> 適切な値が設定。
	SCCP 法表示	00 表示なしを設定。	※最新の BICC/ISUP 勧告に基づくべきであると記 述あり。<6.1.3.4 章参照>
発ユーザ種別	00001001 国内台 00001010 一般発ユーザ 00001011 優先発ユーザ 00001101 試験呼 00001111 公衆電話 から適切な値を設定。 判断不可能な場合は、"00001010"を設定。	00001010 一般発ユーザを設定。<6.1.3.2 章参照>	
通信路要求表 示	-	00000011 3.1kHz オーディオを設定。	•Profile A <6.1.3.5 章参照> 3.1kHz オーディオを設定。 •Profile B <6.1.3.5.1 章参照> SDP 内容より値を決定。

注 1: Q.1912.5 の Profile A(SIP 3GPP モバイル網-PSTN 網)、Profile B(SIP 網-PSTN 網)のパラメータを本表に示し、Profile C(SIP-I)に関しては、
 記述を行わない。

付表 ii-5/JF-IETF-RFC3398 ISDN アクセス表示に「非 ISDN アクセス」を持つ ACM,ANM への
インタワークにおける ISUP デフォルト設定値の差分

パラメータ	要素	JF-IETF-RFC3398 〈付属資料 a. 参照〉	ITU-T 勧告 (Q.1912.5)
逆方向呼表示	課金表示	本付属資料では課金条件までは言及しないが、呼毎に適切なインタワークが必要。	※最新の BICC/ISUP 勧告に基づくべきであると記述あり。〈7.3.1.1 章参照〉
	着ユーザ状態表示	本文(8.2.3 節)の規定に従う 180 受信時 01 加入者空 (subscriber free) 182,183 受信時 00 表示なし (no indicator)を設定。	•Profile A、Profile B 〈7.3.1.1 章、7.3.2 章参照〉 180 受信時 01 加入者空 (subscriber free) 183 はインタワークなし。
	着ユーザ種別表示	00 表示なし 01 一般ユーザ 10 公衆電話 から適切な値を設定。 判断不可能な場合は、“01”を設定。	※最新の BICC/ISUP 勧告に基づくべきであると記述あり。〈7.3.1.1 章参照〉
	エンド・エンド法表示	00 エンド・エンド法が利用できないを設定。	※最新の BICC/ISUP 勧告に基づくべきであると記述あり。〈7.3.1.1 章参照〉
	相互接続表示	0 相互接続なしを設定。	•Profile A 〈7.3.1.1 章 Table34 参照〉 1 相互接続ありを設定。 •Profile B 〈7.3.1.1 章参照〉 180 受信時 適切な値が設定される
	エンド・エンド情報表示	0 エンド・エンド情報利用できないを設定。	※最新の BICC/ISUP 勧告に基づくべきであると記述あり。〈7.3.1.1 章参照〉
	ISUP1 リンク表示	1 ISUP1 リンクであるを設定。	•Profile A 〈7.3.1.1 章 Table34 参照〉 0 ISUP1 リンクでないを設定 •Profile B 〈7.3.1.1 章参照〉 180 受信時 適切な値が設定される
	保留表示	0 保留表示を設定	※最新の BICC/ISUP 勧告に基づくべきであると記述あり。〈7.3.1.1 章参照〉
	ISDN アクセス表示	0 着側のユーザ・網インタフェースが非 ISDN を設定。 ※”1 着側ユーザ・網インタフェースが ISDN”を適用する場合は JT-Q699 に従い、JT-Q699 未規定部分は付属資料 a.2 に従うと記述あり。〈8.2.3 章参照〉	•Profile A 〈7.3.1.1 章 Table34 参照〉 0 着側のユーザ・網インタフェースが非 ISDN を設定。 •Profile B 〈7.3.1.1 章参照〉 180 受信時 適切な値が設定される
	エコー制御装置表示	0 入回線ハーフエコー制御装置挿入せず 1 入回線ハーフエコー制御装置挿入の一方を設定	※最新の BICC/ISUP 勧告に基づくべきであると記述あり。〈7.3.1.1 章参照〉
SCCP 法表示	00 表示なしを設定。	※最新の BICC/ISUP 勧告に基づくべきであると記述あり。〈7.3.1.1 章参照〉	

注 1: Q.1912.5 の Profile A (SIP 3GPP モバイル網-PSTN 網)、Profile B (SIP 網-PSTN 網)のパラメータを本表に示し、Profile C (SIP-I)に関しては、記述を行わない。

付表 ii -6 / JF-IETF-RFC3398 参照文書の差分

		JF-IETF-RFC3398 〈参考 1.2、本文 18 章、19 章参照〉	ITU-T 勧告(Q.1912.5) 〈2 章、ANNEX C.1 参照〉
ITU-T		Q.118, Q.737, Q.763, Q.764, Q.767, Q.850, <i>E.164</i>	<i>Q.731.7, Q.732.2, Q.732.3, Q.732.4, Q.732.5, Q.732.7, Q.733.1, Q.733.2, Q.733.3, Q.733.4, Q.733.5, Q.734.1, Q.734.2, Q.735.1, Q.735.3, Q.735.6, Q.736.1, Q.736.3, Q.737.1, Q.761, Q.762, Q.763, Q.764, Q.850, Q.1902.1 to Q.1902.4, T.38</i>
TTC	標準	<i>JT-Q763, JT-Q764, JT-Q850, JT-Q699 JJ-90.10, JJ-90.21, JJ-90.22</i>	—
IETF	RFC	RFC2046, <i>RFC2119</i> , RFC2806, RFC2833, <i>RFC2916, RFC2960</i> , RFC2976, RFC3204, RFC3261, RFC3262, RFC3323, RFC3326, RFC3311, <i>RFC3372, RFC3398</i>	RFC2046, <i>RFC2327</i> , RFC2806, RFC2833, RFC2976(*), RFC3204(*), RFC3261, RFC3262(+), <i>RFC3264, RFC3267</i> , RFC3311, RFC3312(+), RFC3323, <i>RFC3325</i> , RFC3326, <i>RFC3389, RFC3550, RFC3551</i>
	Internet Draft	<i>"Extensions to the 'tel' and 'fax' URLs to Support Number Portability and Freephone Service"</i>	—
ANSI		<i>T1.113</i>	—
*: Q.1912.5 の Profile A と Profile B では"Not Supported"、Profile C では"Supported"である。 +: Q.1912.5 の Profile A では"Supported"、Profile B と Profile C では"Optional"である。			